



**THE DATASHEET OF
LT8631EFE#PBF**



100V, 1A Synchronous Micropower Step-Down Regulator

FEATURES

- **Ultrawide Input Voltage Range: 3V to 100V**
- **Output Voltage Range: 0.8V to 60V**
- **Internal Synchronous Switches**
- **Low Ripple Burst Mode® Operation:**
 - 16 μ A I_Q at 12V_{IN} to 5V_{OUT} Output Ripple <10mV_{P-P}
 - 7 μ A I_Q at 48V_{IN} to 5V_{OUT} Output Ripple <10mV_{P-P}
- **Low Dropout: 99% Maximum Duty Cycle**
- **Peak Current Mode Control**
- **Fixed Frequency Operation: 100kHz to 1MHz**
- **Synchronization Input**
- **Programmable Undervoltage Lockout**
- **Power Good Flag**
- Flexible Output Voltage Tracking
- Short-Circuit Protection
- Low Shutdown Current: 5 μ A
- Tolerates Pin Open/Short Faults
- Thermally Enhanced 20-Lead TSSOP with High Voltage Lead Spacing

APPLICATIONS

- Automotive Supplies
- Telecom Supplies
- Distributed Supply Regulation

DESCRIPTION

The LT[®]8631 is a current mode PWM step-down DC/DC converter with internal synchronous switches that provide current for output loads up to 1A. The wide input range of 3V to 100V makes the LT8631 suitable for regulating power from a wide variety of sources, including automotive and industrial systems and 36V to 72V telecom supplies. Low ripple Burst Mode operation enables high efficiency operation down to very low output currents while keeping the output ripple below 10mV_{P-P}. Resistor programmable 100kHz to 1MHz frequency range and synchronization capability enable optimization between efficiency and external component size. The soft-start feature controls the ramp rate of the output voltage, eliminating input current surge during start-up, while also providing output tracking. A power good flag signals when the output voltage is within $\pm 7.5\%$ of the regulated output. Undervoltage lockout can be programmed using the EN/UV pin. Shutdown mode reduces the total quiescent current to < 5 μ A. The LT8631 is available in a 20-lead TSSOP package with exposed pad for low thermal resistance and high voltage lead spacing.

LT, LT, LTC, LTM, Linear Technology, Burst Mode and the Linear logo are registered trademarks of Analog Devices, Inc. All other trademarks are the property of their respective owners.

TYPICAL APPLICATION

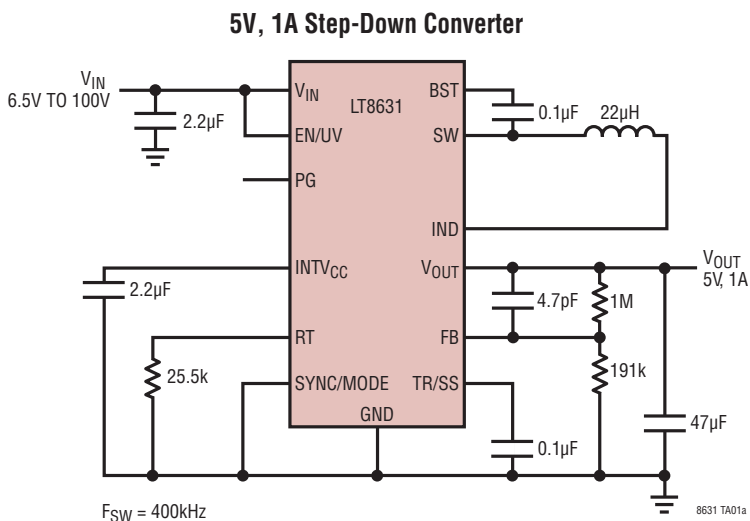

Efficiency vs Load Current

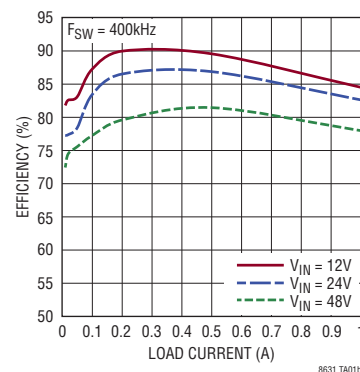

LT8631

ABSOLUTE MAXIMUM RATINGS

(Note 1)

V_{IN} , EN/UV, PG	100V
IND, V_{OUT}	60V/−0.3V
SYNC/MODE	6V
FB, TR/SS	4V
Operating Junction Temperature Range	
LT8631EFE (Note 2)	−40°C to 125°C
LT8631IFE (Note 2)	−40°C to 125°C
LT8631HFE (Note 2)	−40°C to 150°C
Storage Temperature Range	
	−65°C to 150°C

PIN CONFIGURATION

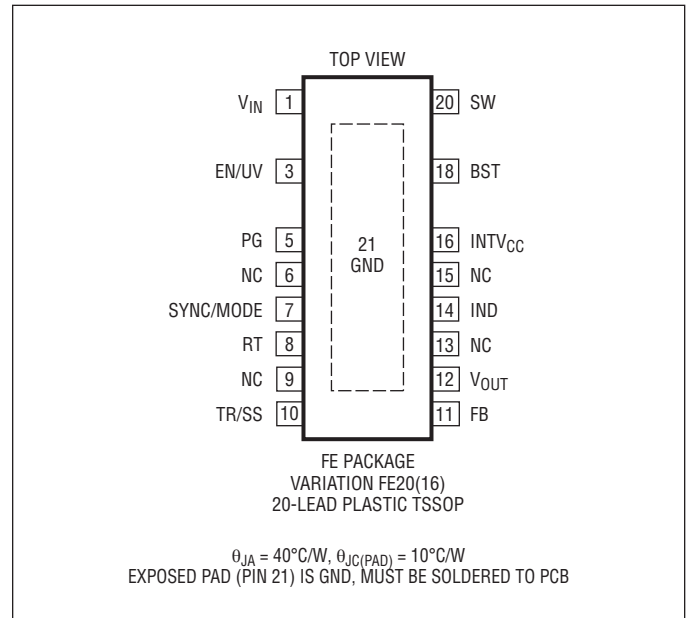

ORDER INFORMATION <http://www.linear.com/product/LT8631#orderinfo>

LEAD FREE FINISH	TAPE AND REEL	PART MARKING*	PACKAGE DESCRIPTION	TEMPERATURE RANGE
LT8631EFE#PBF	LT8631EFE#TRPBF	LT8631FE	20-Lead Plastic TSSOP	−40°C to 125°C
LT8631IFE#PBF	LT8631IFE#TRPBF	LT8631FE	20-Lead Plastic TSSOP	−40°C to 125°C
LT8631HFE#PBF	LT8631HFE#TRPBF	LT8631FE	20-Lead Plastic TSSOP	−40°C to 150°C

Consult LTC Marketing for parts specified with wider operating temperature ranges. *The temperature grade is identified by a label on the shipping container. Consult LTC Marketing for information on nonstandard lead based finish parts.

For more information on lead free part marking, go to: <http://www.linear.com/leadfree/>

For more information on tape and reel specifications, go to: <http://www.linear.com/tapeandreel/>. Some packages are available in 500 unit reels through designated sales channels with #TRMPBF suffix.

ELECTRICAL CHARACTERISTICS The ● denotes the specifications which apply over the full operating temperature range, otherwise specifications are at $T_J = 25^\circ\text{C}$. $V_{IN} = 15\text{V}$, $V_{EN/UV} = 2\text{V}$, unless otherwise specified. (Note 2)

PARAMETER	CONDITIONS		MIN	TYP	MAX	UNITS
EN/UV Voltage Threshold	$V_{EN/UV}$ Rising	●	1.14	1.19	1.24	V
EN/UV Voltage Hysteresis			9	17	25	mV
EN/UV Input Current				5	100	nA
V_{IN} Undervoltage Lockout	$V_{FB} = 0.9\text{V}$	●	2.74	2.8	3.05	V
Quiescent Current from V_{IN}	$V_{EN/UV} = 0\text{V}$ $V_{FB} = 0.9\text{V}$, $V_{VOUT} = 0\text{V}$ $V_{FB} = 0.9\text{V}$, $V_{VOUT} = 5\text{V}$			5 16 3.6	7 30 5.6	μA μA μA
Quiescent Current from V_{IN}	$V_{EN/UV} = 0\text{V}$ $V_{FB} = 0.9\text{V}$, $V_{VOUT} = 0\text{V}$ $V_{FB} = 0.9\text{V}$, $V_{VOUT} = 5\text{V}$	● ● ●		5 16 3.6	25 64 22	μA μA μA
Quiescent Current from V_{OUT}	$V_{FB} = 0.9\text{V}$, $V_{VOUT} = 5\text{V}$	●		10	45	μA
V_{IN} Current in Regulation	$V_{VOUT} = 5\text{V}$, $I_{LOAD} = 100\mu\text{A}$ $V_{VOUT} = 5\text{V}$, $V_{SYNC/MODE} = 2\text{V}$, $I_{LOAD} = 100\mu\text{A}$ $V_{VOUT} = 5\text{V}$, $I_{LOAD} = 1\text{mA}$			90 180 475	160 350 650	μA μA μA
Feedback Bias Current	$V_{FB} = 0.8\text{V}$		-25	-15		nA
Feedback Voltage (V_{FBREF})	$V_{VOUT} = 5\text{V}$, $I_{LOAD} = 100\text{mA}$	●	796	808	820	mV
Feedback Voltage Line Regulation	$V_{IN} = 7\text{V}$ to 100V , $V_{OUT} = 5\text{V}$, $I_{LOAD} = 500\text{mA}$			0.01	0.2	%/V
Feedback Voltage Load Regulation	$V_{IN} = 15\text{V}$, $V_{OUT} = 5\text{V}$, $I_{LOAD} = 100\text{mA}$ to 1A		-1.5	-0.3		%/A
Track/Soft-Start Source Current	$V_{FB} = 0.9\text{V}$, $V_{TR/SS} = 0\text{V}$		-6.5	-4.5	-2.5	μA
Track/Soft-Start VOH	$V_{FB} = 0.9\text{V}$		2.9	3.0	3.2	V
Track/Soft-Start Sink Current	$V_{FB} = 0.7\text{V}$, $V_{TR/SS} = 1\text{V}$		15	30	45	μA
Track/Soft-Start VOL	$V_{FB} = 0\text{V}$			50	75	mV
Track/Soft-Start to Feedback Offset	$V_{TR/SS} = 0.4\text{V}$, $V_{VOUT} = 5\text{V}$, $I_{LOAD} = 100\text{mA}$		-25	5	25	mV
Track/Soft-Start Sink Current POR (Note 4)	$V_{FB} = 0.9\text{V}$, $V_{TR/SS} = 0.2\text{V}$		180	230		μA
PG Leakage Current	$V_{FB} = 0\text{V}$, $V_{PG} = 100\text{V}$		-200	0	200	nA
PG Lower Threshold % of V_{FBREF} (Note 5)	V_{FB} Rising	●	-10.5	-7.5	-4.5	%
PG Upper Threshold % of V_{FBREF} (Note 5)	V_{FB} Falling	●	4.5	7.5	10.5	%
PG Hysteresis (Note 5)			1.4	1.9	2.3	%
PG Sink Current	$V_{FB} = 0.7\text{V}$, $V_{PG} = 0.2\text{V}$			980		μA
Switching Frequency	$R_{RT} = 187\text{k}\Omega$, $V_{VOUT} = 5\text{V}$, $I_{LOAD} = 100\text{mA}$ $R_{RT} = 19.6\text{k}\Omega$, $V_{VOUT} = 5\text{V}$, $I_{LOAD} = 100\text{mA}$ $R_{RT} = 8.66\text{k}\Omega$, $V_{VOUT} = 5\text{V}$, $I_{LOAD} = 100\text{mA}$	●	75 460 925	100 500 1000	125 540 1075	kHz kHz kHz
Minimum Switch ON Time	$V_{IN} = 15\text{V}$ to 25V , $R_{RT} = 8.66\text{k}\Omega$, $V_{VOUT} = 1.5\text{V}$, $I_{LOAD} = 500\text{mA}$			100	120	ns
Minimum Switch OFF Time	$V_{IN} = 5\text{V}$, $R_{RT} = 8.66\text{k}\Omega$, $V_{VOUT} = 5\text{V}$, $I_{LOAD} = 500\text{mA}$			190		ns
IND to V_{OUT} Burst Current (Note 6)				280		mA
IND to V_{OUT} Peak Current (Note 7)			1.4	2.1	2.8	A
Maximum V_{OUT} Current in Regulation	$V_{IN} = 7.5\text{V}$, $R_{RT} = 19.6\text{k}\Omega$, $V_{VOUT} = 5\text{V}$, $L = 15\mu\text{H}$ $V_{IN} = 50\text{V}$, $R_{RT} = 19.6\text{k}\Omega$, $V_{VOUT} = 5\text{V}$, $L = 15\mu\text{H}$	●	1.00 1.2	1.35 1.8	1.8 2.4	A A
Switch Pin Leakage Current	$V_{SW} = 0\text{V}$, $V_{EN/UV} = 0\text{V}$ $V_{SW} = 100\text{V}$, $V_{IN} = 100\text{V}$, $V_{EN/UV} = 0\text{V}$			50 0.5	500 2.0	nA μA
Top Switch On-Resistance				775		m Ω
Bottom Switch On-Resistance				550		m Ω
BST Pin Current	$V_{BST} = 18\text{V}$			180		μA

ELECTRICAL CHARACTERISTICS

The ● denotes the specifications which apply over the full operating temperature range, otherwise specifications are at $T_J = 25^\circ\text{C}$. $V_{IN} = 15\text{V}$, $V_{EN/UV} = 2\text{V}$, unless otherwise specified. (Note 2)

PARAMETER	CONDITIONS	MIN	TYP	MAX	UNITS
BST Pin Threshold (Note 8)			2.4		V
SYNC/MODE Pin Current	$V_{\text{SYNC/MODE}} = 3\text{V}$	2	3.4	5.5	μA
SYNC/MODE Threshold		1.0	1.5	2.0	V
Synchronization Range		100		1000	kHz

Note 1: Stresses beyond those listed under Absolute Maximum Ratings may cause permanent damage to the device. Exposure to any Absolute Maximum Rating condition for extended periods may affect device reliability and lifetime.

Note 2: The LT8631EFE is guaranteed to meet performance specifications from 0°C to 125°C junction temperature. Specifications over the -40°C to 125°C operating junction temperature range are assured by design, characterization and correlation with statistical process controls. The LT8631IFE is guaranteed over the full -40°C to 125°C operating junction temperature range. The LT8631HFE is guaranteed over the full -40°C to 150°C operating junction temperature range. High junction temperatures degrade operating lifetimes. Operating lifetime is derated at junction temperatures greater than 125°C .

Note 3: The LT8631 includes overtemperature protection that is intended to protect the device during thermal overload conditions. Internal junction temperature will exceed 150°C when the overtemperature circuitry is active.

Note 4: An internal power on reset (POR) latch is set on the positive transition of the EN/UV pin through its threshold or thermal shutdown. The output of the latch activates a current source on the TR/SS pin which typically sinks $230\mu\text{A}$ while discharging the TR/SS capacitor. The latch is reset when the TR/SS pin is driven below the soft-start POR threshold or the EN/UV pin is taken below its threshold.

Note 5: The threshold is expressed as a percentage of the feedback reference voltage.

Note 6: The IND to V_{OUT} burst current is defined as the maximum value of current flowing from the IND pin to the V_{OUT} during a switch cycle when operating in Burst Mode.

Note 7: The IND to V_{OUT} peak current is defined as the maximum value of current flowing from the IND pin to the V_{OUT} during a switch cycle.

Note 8: The BST pin threshold is defined as the minimum voltage between the BST and SW pins to keep the top switch on. If the voltage falls below the threshold when the top switch is on, a minimum switch off pulse will be generated.

TYPICAL PERFORMANCE CHARACTERISTICS

Efficiency at $V_{OUT} = 5V$

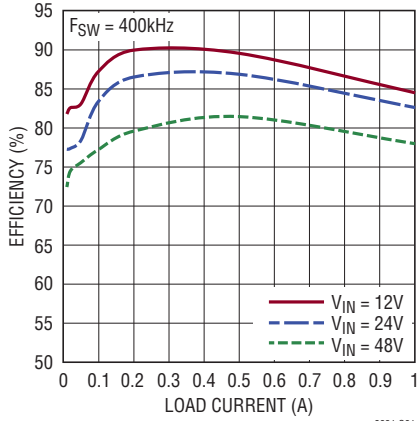

8631 G01

Efficiency at $V_{OUT} = 3.3V$

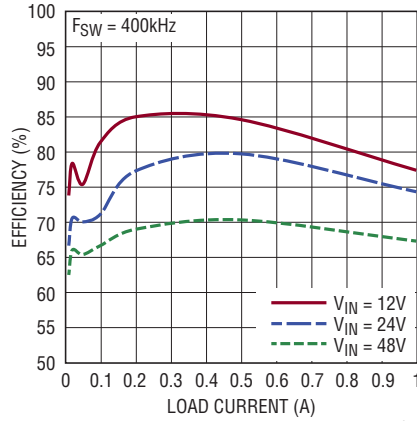

8631 G02

Efficiency at $V_{OUT} = 5V$

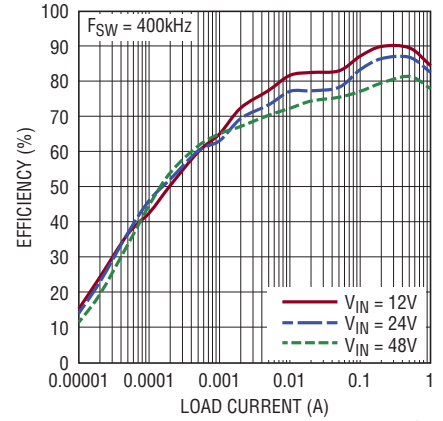

8631 G03

Efficiency at $V_{OUT} = 3.3V$

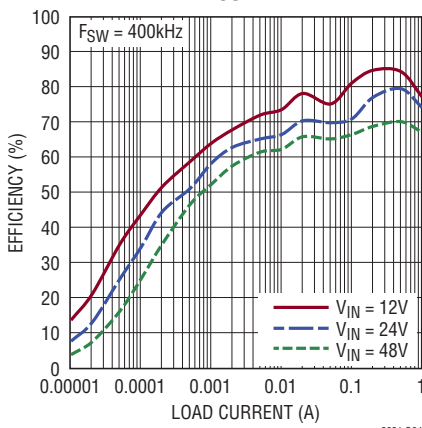

8631 G04

Efficiency

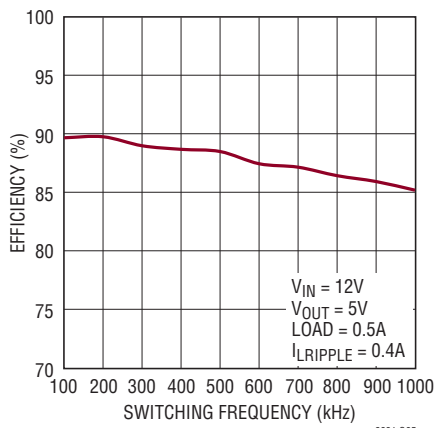

8631 G05

Shutdown Supply Current

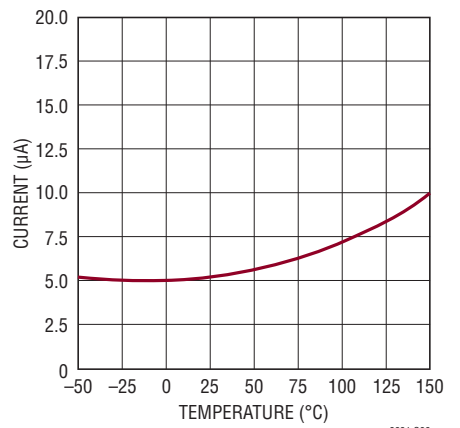

8631 G06

EN/UV Thresholds

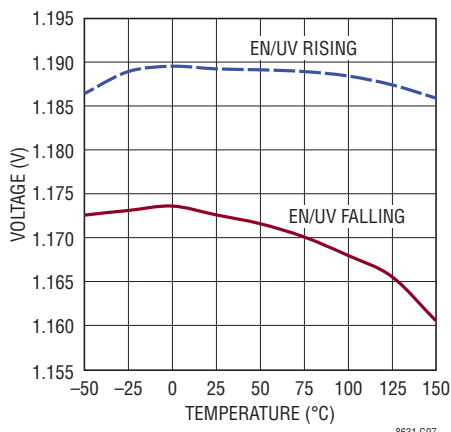

8631 G07

V_{IN} Undervoltage Lockout

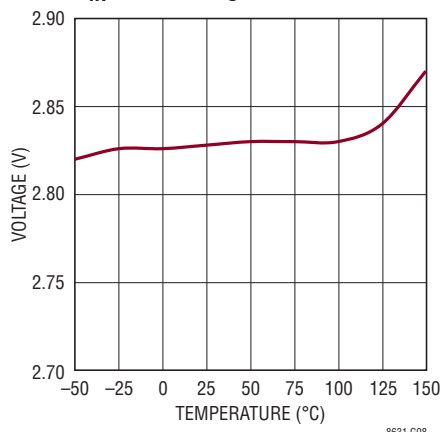

8631 G08

Reference Voltage

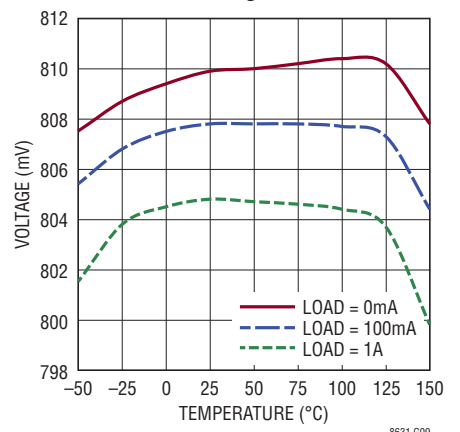

8631 G09

TYPICAL PERFORMANCE CHARACTERISTICS

Switching Frequency

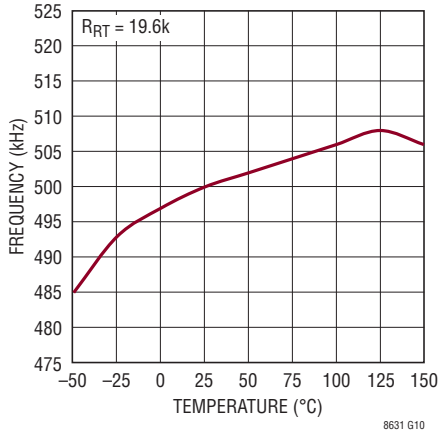

Burst Frequency

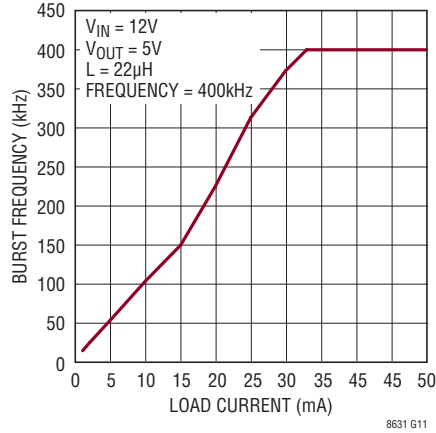

No Load Supply Current

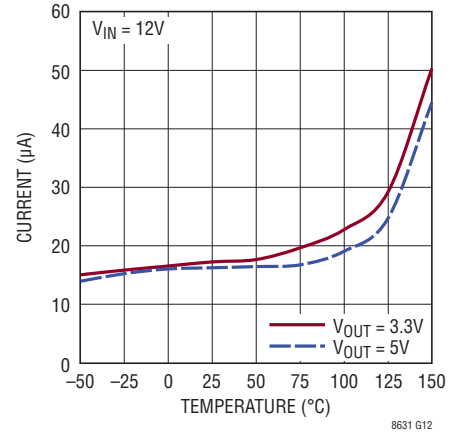

No Load Supply Current

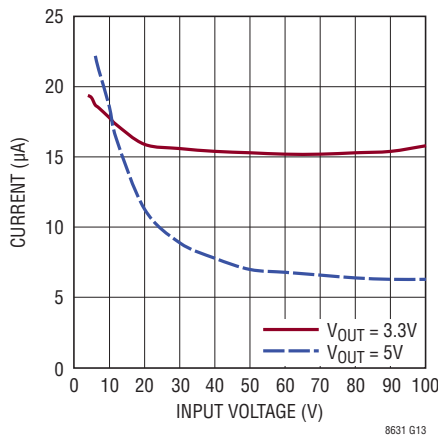

Sleep Quiescent Currents

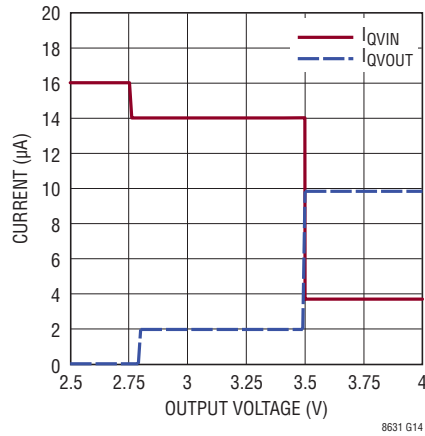

Peak Switch Current

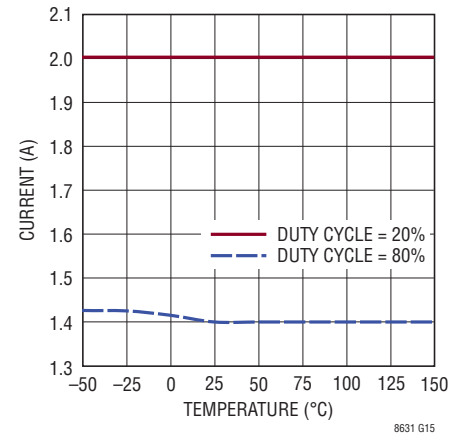

Peak Switch Current

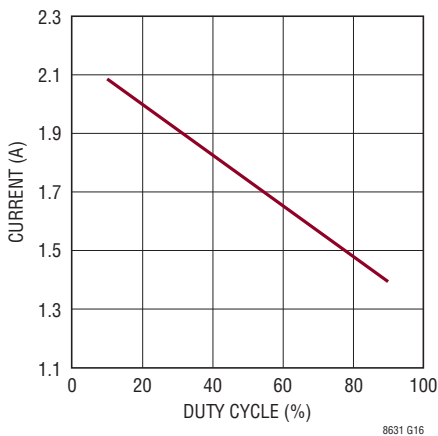

Minimum On-Time

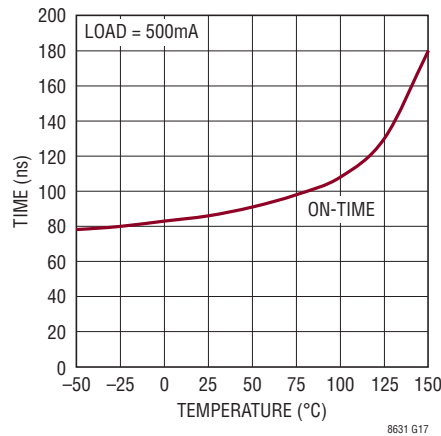

Switch Resistance

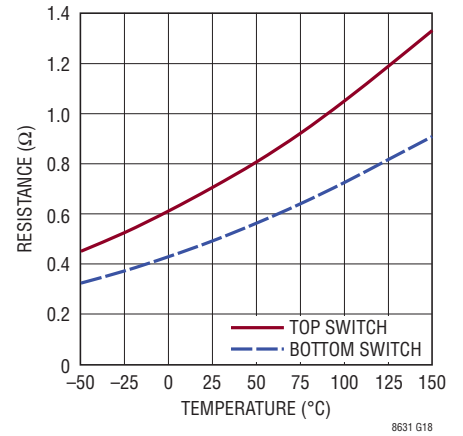

TYPICAL PERFORMANCE CHARACTERISTICS

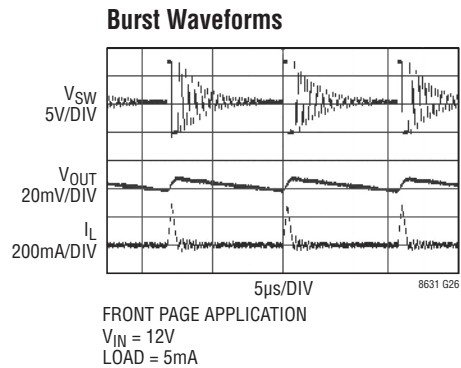
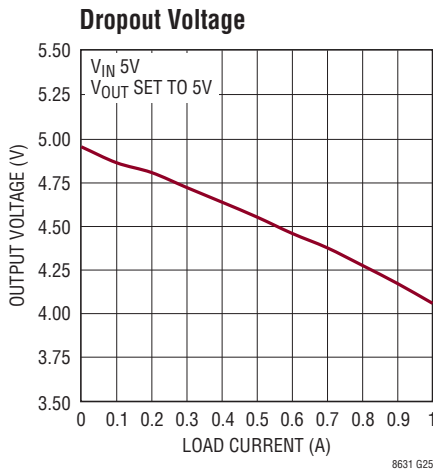
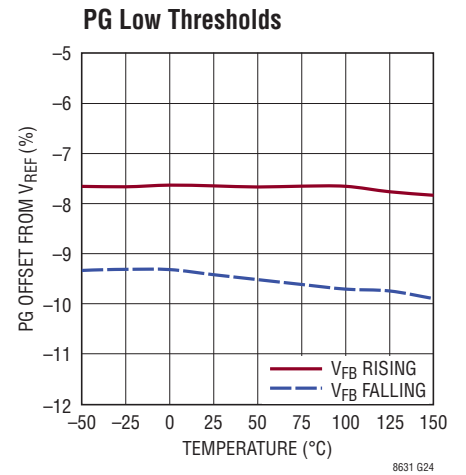
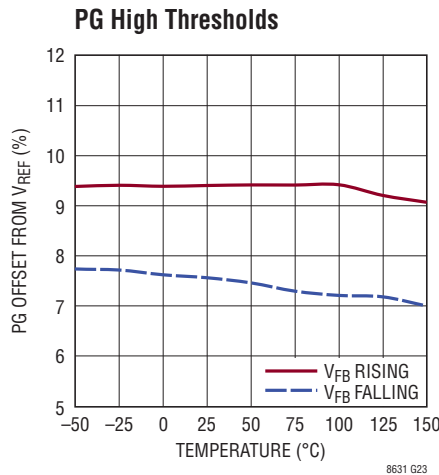
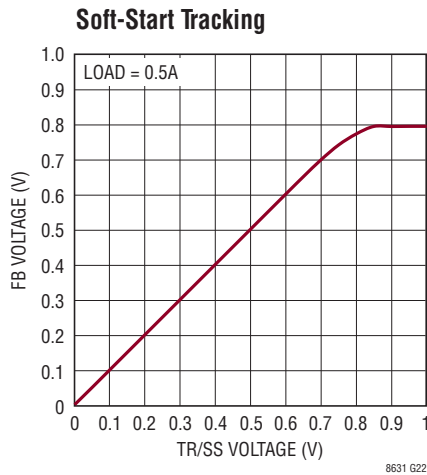
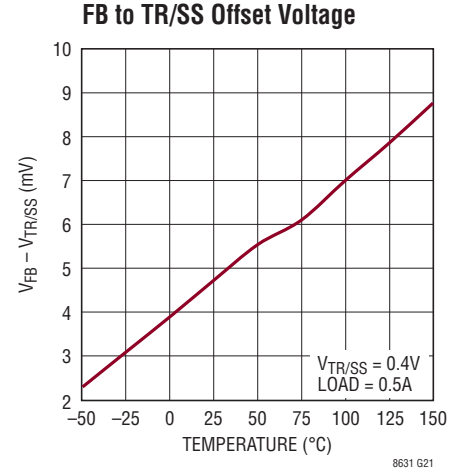
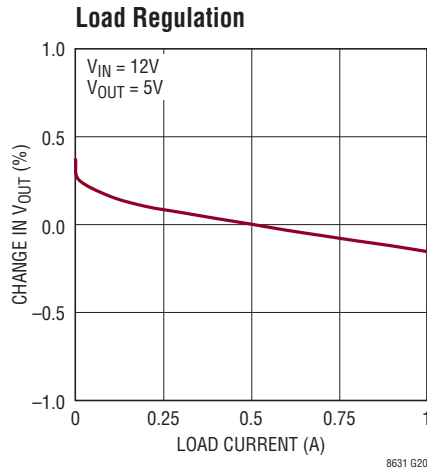
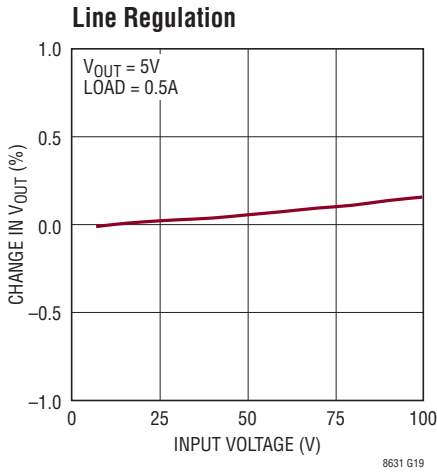

TYPICAL PERFORMANCE CHARACTERISTICS

Burst Waveforms

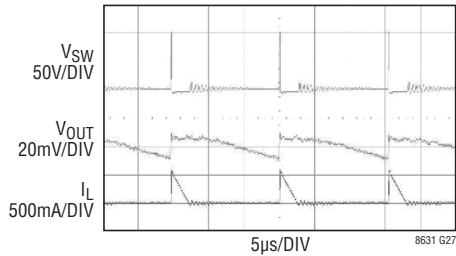

FRONT PAGE APPLICATION
 $V_{IN} = 100V$
 $I_L = 50mA$

Switching Waveforms

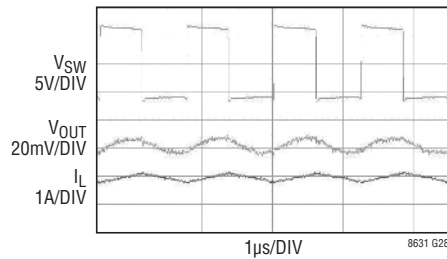

FRONT PAGE APPLICATION
 $V_{IN} = 12V$
 $I_L = 1A$

Switching Waveforms

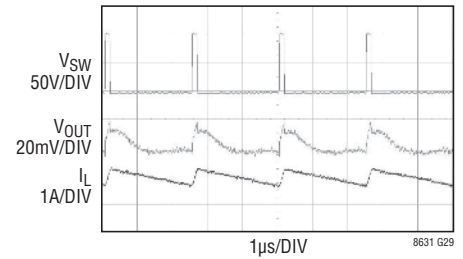

FRONT PAGE APPLICATION
 $V_{IN} = 100V$
 $I_L = 1A$

Load Transient Response

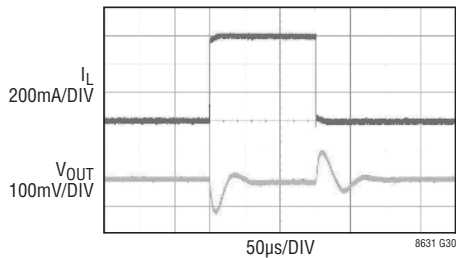

FRONT PAGE APPLICATION
 200mA to 800mA LOAD TRANSIENT
 $V_{IN} = 15V$

Input Voltage Transient Response

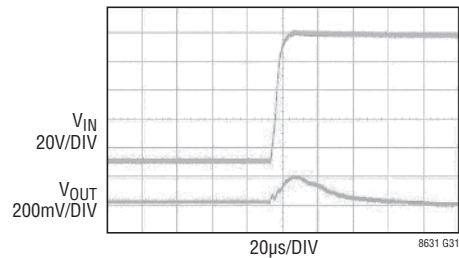

FRONT PAGE APPLICATION
 12V to 100V INPUT VOLTAGE TRANSIENT
 $I_L = 100mA$
 $C_{OUT} = 2 \times 47\mu F$

Start-Up Dropout Performance

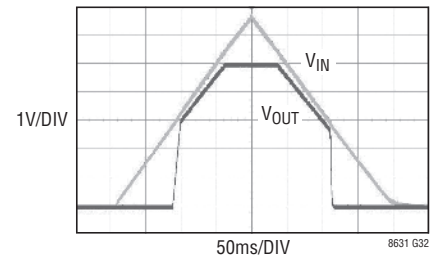

FRONT PAGE APPLICATION
 $I_L = 500mA$

PIN FUNCTIONS

V_{IN} (Pin 1): The V_{IN} pin powers the internal control circuitry and is monitored by an undervoltage lockout comparator. The V_{IN} pin is also connected to the drain of the on chip power switch. The V_{IN} pin has high di/dt edges and must be decoupled to the GND pin of the device. The input decouple capacitor should be placed as close as possible to the V_{IN} and GND pins.

EN/UV (Pin 3): The EN/UV pin is used to enable the LT8631 or to program the undervoltage lockout threshold with external resistors. The LT8631 is in shutdown mode ($I_Q < 5\mu\text{A}$) when the EN/UV pin voltage is below 1.19V and active mode when the voltage exceeds 1.19V. Tie EN/UV to the V_{IN} pin if the EN/UV feature isn't required.

PG (Pin 5): The PG pin is an open drain output that sinks current when the feedback voltage deviates from the regulation point by $\pm 7.5\%$. The PG pin has 1.9% of hysteresis.

NC6 (Pin 6): No Internal Connection. Leave this pin open or connect to GND.

SYNC/MODE (Pin 7): The voltage present at the SYNC/MODE pin determines the LT8631 operating mode. Ground this pin for low ripple Burst Mode operation at low output loads. Apply a DC voltage greater than the SYNC/MODE threshold for pulse-skipping operation at low output loads. The LT8631 will synchronize its switching frequency to an external clock applied to the SYNC/MODE pin. The external clock signal must have a duty cycle between 20% and 80% and be within the specified frequency range. The LT8631 will operate in pulse-skipping mode when the SYNC/MODE pin is driven with an external clock.

RT (Pin 8): A resistor with a value between 8.66k and 187k must be connected between the RT pin and the GND pin. The R_T resistor sets the switching frequency. Do not leave this pin floating.

NC9 (Pin 9): No Internal Connection. Leave this pin open or connect to GND.

TR/SS (Pin 10): A capacitor with a minimum value of 100pF must be connected between the TR/SS pin and the GND

pin. The voltage ramp rate on the TR/SS pin determines the output voltage ramp rate. This pin can also be used for voltage tracking. Do not leave this pin floating.

FB (Pin 11): The FB pin is the negative input to the error amplifier. The output switches to regulate this pin to 0.808V with respect to the GND pin.

V_{OUT} (Pin 12): The V_{OUT} pin is the output to the internal sense resistor that measures current flowing in the inductor. Connect the output capacitor from the V_{OUT} pin to the GND pin.

NC13 (Pin 13): No Internal Connection. Leave this pin open or connect to GND.

IND (Pin 14): The IND pin is the input to the internal sense resistor that measures current flowing in the inductor.

NC15 (Pin 15): No Internal Connection. Leave this pin open or connect to GND.

INTV_{CC} (Pin 16): The INTV_{CC} pin is the bypass pin for the internal 3V regulator. Connect a 2.2 μF bypass capacitor from the INTV_{CC} pin to the GND pin. Do not load the INTV_{CC} pin with external circuitry.

BST (Pin 18): The BST pin is used to provide a drive voltage, higher than the V_{IN} voltage, to the topside power switch. Place a 0.1 μF capacitor between the BST and SW pins as close as possible to the device.

SW (Pin 20): The SW pin is the output of the internal power switches. Place the inductor and BST capacitor as close as possible to keep the SW PCB trace short.

GND (Exposed Pad Pin 21): The exposed pad GND pin is the *ONLY GROUND CONNECTION* for the device. The exposed pad should be soldered to a large copper area to reduce thermal resistance. The GND pin also serves as small signal ground. For ideal operation all small signal ground paths should connect to the GND pin at a single point avoiding any high current ground returns.

BLOCK DIAGRAM

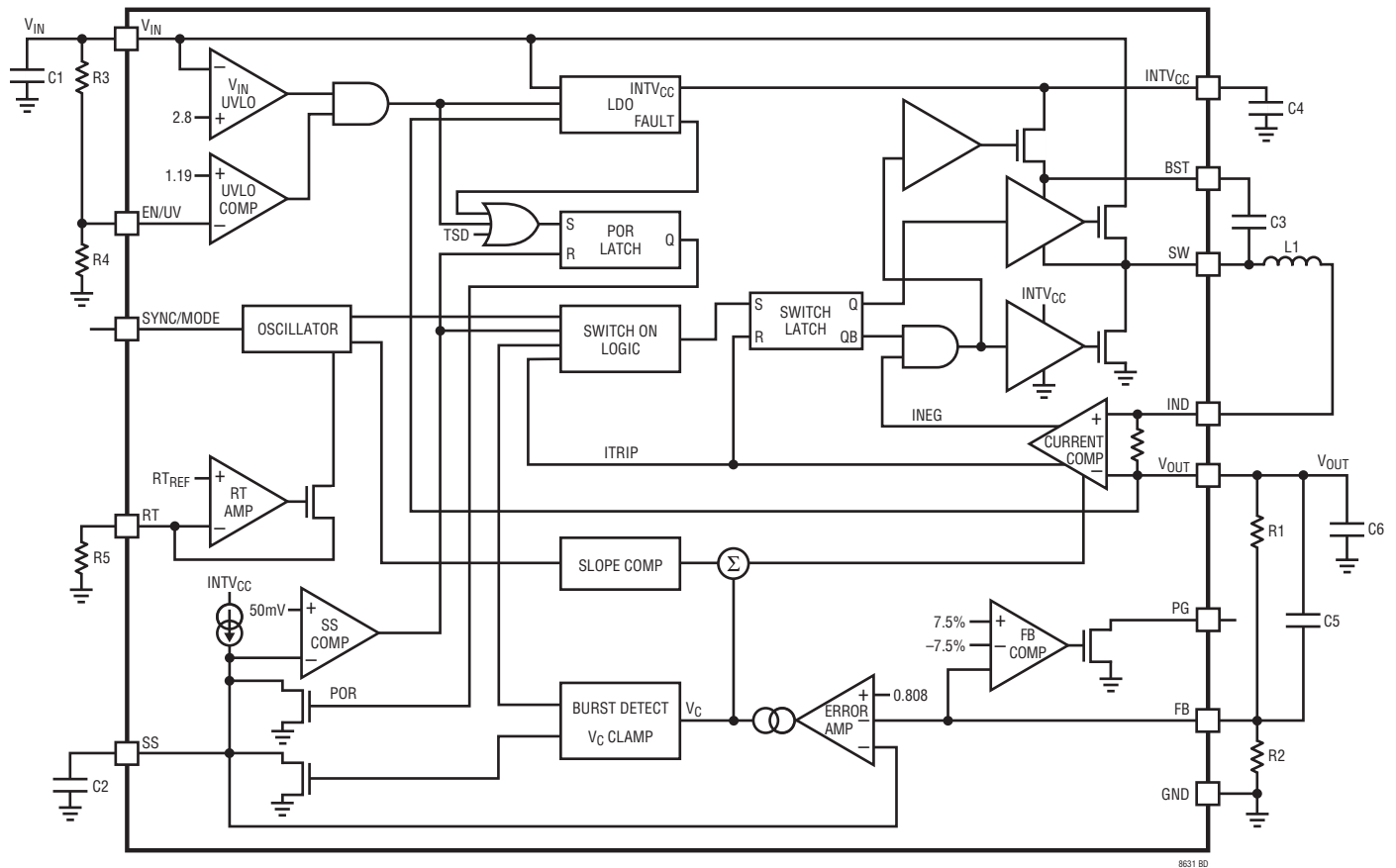

Figure 1. Block Diagram

OPERATION

The LT8631 is a monolithic, constant frequency, current mode step-down DC/DC converter. When the voltage on the EN/UV pin is below its 1.19V threshold, the LT8631 is shutdown and draws less than 5µA from the input supply. When the EN/UV pin is driven above 1.19V, the internal bias circuits turn on generating an internal regulated voltage, 0.808V feedback reference, a 4.5µA soft-start current reference, and a power on reset (POR) signal.

During power-up the POR signal is set and in turn sets the soft-start latch. When the soft-start latch is set, the TR/SS pin will be discharged to ground to ensure proper start-up operation. When the TR/SS pin drops below 50mV, the

soft-start latch is reset. Once the latch is reset the soft-start capacitor starts to charge with a typical value of 4.5µA.

The error amplifier is a transconductance amplifier that compares the FB pin voltage to the lowest voltage present at either the TR/SS pin or an internal 0.808V reference. Since the TR/SS pin is driven by a constant current source, a single capacitor on the soft-start pin will generate a controlled linear ramp on the output voltage. The voltage on the output of the error amplifier (internal V_C node in Figure 1) sets the peak current of each switch cycle and also determines when to enable low quiescent current burst mode operation.

OPERATION

The internal oscillator generates a clock signal at a frequency determined by the resistor connected from the RT pin to ground. Alternatively, if a synchronization signal is detected by the LT8631 SYNC/MODE pin, the internal clock will be generated at the incoming frequency on the rising edge of the synchronization pulse.

When the voltage on the V_C node rises above the switching threshold, the clock set-pulse sets the driver flip-flop, which turns on the internal top power switch. This causes current from V_{IN} , through the top switch, inductor, and internal sense resistor, to increase. When the voltage drop across the internal sense resistor exceeds a predetermined level set by the voltage on the internal V_C node, the flip-flop is reset and the internal top switch is turned off. Once the top switch is turned off the inductor will drive the voltage at the SW pin low. The synchronous power switch will turn on, decreasing the current in the inductor, until the next clock cycle or the inductor current falls to zero. However, if the internal sense resistor voltage exceeds the predetermined level at the start of a clock cycle, the flip-flop will not be set resulting in a further decrease in the inductor current. Alternatively, if the current through the inductor doesn't exceed the current demanded by the V_C voltage during the clock cycle, the top switch will stay on until the required current is reached or the voltage on the boost pin falls below its minimum required value. Since the output current is controlled by the internal V_C voltage, output regulation is achieved by the error amplifier continuously adjusting the V_C voltage.

The regulators' maximum output current occurs when the internal V_C node is driven to its maximum clamp value by the error amplifier. The value of the typical maximum switch current is 2A. If the current demanded by the output exceeds the maximum current dictated by the internal V_C clamp, the TR/SS pin will be discharged, lowering the regulation point until the output voltage can be supported by the maximum current. Once the overload condition is removed, the regulator will soft-start from the overload regulation point.

EN/UV pin control or thermal shutdown will set the soft-start latch, resulting in a complete soft-start sequence.

Comparators monitoring the FB pin voltage will pull the PG pin low if the output voltage varies more the $\pm 7.5\%$ from the feedback reference voltage. The PG comparators have 1.9% of hysteresis.

In light load situations (low V_C voltage), the LT8631 operates in Burst Mode to optimize efficiency. Between bursts, all circuitry associated with controlling the output switch is shut down, reducing the input supply current to $16\mu\text{A}$. In a typical application, $16\mu\text{A}$ will be consumed from the input supply when regulating with no load. The SYNC/MODE pin is tied low to use Burst Mode operation and can be tied to a logic high to use pulse-skipping mode. During pulse-skipping mode and light loads, switch pulses are skipped to regulate the output and the quiescent current will be typically several hundred μA .

To improve efficiency across all loads, supply current to internal circuitry is sourced from the V_{OUT} pin when it's biased at 3.5V or above. If the V_{OUT} pin is below 3.5V the internal supply current is sourced from V_{IN} .

APPLICATIONS INFORMATION

Achieving Low Quiescent Current

To enhance efficiency at light loads, the LT8631 operates in low ripple Burst Mode operation, which keeps the output capacitor charged to the desired output voltage while minimizing the input quiescent current and output voltage ripple. In Burst Mode operation the LT8631 delivers single small pulses of current to the output capacitor followed by sleep periods where the output power is supplied by the output capacitor. While in sleep mode the LT8631 typically consumes 16 μ A.

As the output load decreases, the frequency of single current pulses decreases (see Figure 2) and the percentage of time the LT8631 is in sleep mode increases, resulting in much higher light load efficiency than for typical converters. By maximizing the time between pulses, the converter quiescent current approaches 16 μ A for a typical application when there is no output load. Therefore, to optimize the quiescent current performance at light loads, the current in the feedback resistor divider must be minimized as it appears to the output as a load current.

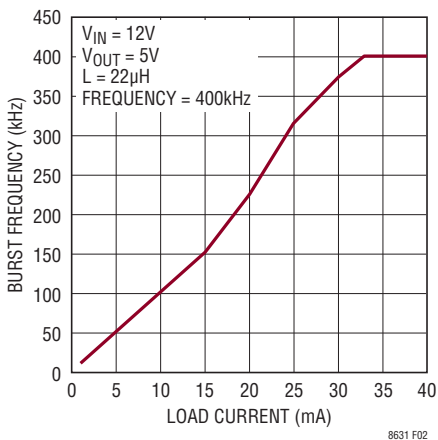

Figure 2. Burst Frequency vs Load Current

While in Burst Mode operation the peak inductor current is approximately 280mA resulting in output voltage ripple shown in Figure 3. Increasing the output capacitance will decrease the output ripple proportionately. As load ramps upward from zero the switching frequency will increase but only up to the switching frequency programmed by the resistor at the RT pin as shown in Figure 2. The output load at which the LT8631 reaches the programmed frequency varies based on input voltage, output voltage, and inductor choice.

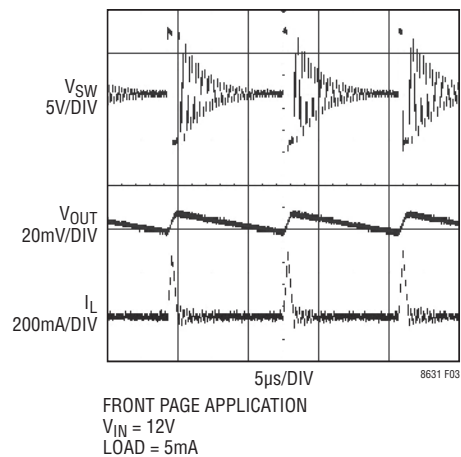

Figure 3. Burst Mode Operation

For some applications it is desirable for the LT8631 to operate in pulse-skipping mode. In pulse-skipping mode, the full switching frequency is reached as a lower output load than in Burst Mode operation at the expense of increased quiescent current. To enable pulse-skipping mode, the SYNC/MODE pin is tied high either to a logic output or to the INTV_{CC} pin. When an external clock signal is applied to the SYNC/MODE pin, the LT8631 will operate in pulse-skipping mode.

APPLICATIONS INFORMATION

Choosing the Output Voltage

The output voltage is programmed with a resistor divider between the output and the FB pin. Choose the 1% resistors according to:

$$R1 = R2 \left(\frac{V_{OUT}}{0.808} - 1 \right)$$

Reference designators refer to the Block Diagram in Figure 1.

If low input quiescent current and good light-load efficiency are desired, use large resistor values for the FB resistor divider. The current flowing in the divider acts as a load current, and will increase the no-load input current to the converter, which is approximately:

$$I_Q = I_{QVIN} + \left(I_{QVOUT} + \left(\frac{V_{OUT}}{R1 + R2} \right) \right) \cdot \left(\frac{V_{OUT}}{V_{IN}} \right) \cdot \left(\frac{1}{n} \right)$$

where I_{QVIN} is the quiescent current of the LT8631 and the second term is the quiescent current drawn from the output (I_{QVOUT}) plus current in the feedback divider reflected to the input of the buck operating at its light load efficiency n . For a 5V application with $R1 = 1M\Omega$ and $R2 = 191k\Omega$, the feedback divider draws $4.2\mu A$. With $V_{IN} = 12V$ $I_{QVIN} = 3.6\mu A$, $I_{QVOUT} = 10\mu A$ and $n = 50\%$, the no-load quiescent current is approximately $16\mu A$. For applications with output voltages less than 2.8V, $I_{QVOUT} = 0\mu A$ and I_{QVIN} is typically $16\mu A$. Graphs of I_{QVIN} and I_{QVOUT} vs V_{OUT} are in the Typical Performance Characteristics section.

When using FB resistors greater than 200k, a 4.7pF to 10pF phase lead capacitor should be connected from V_{OUT} to FB.

Choosing the Switching Frequency

The LT8631 switching frequency can be programmed over a 100kHz to 1MHz range by using a resistor tied from R_T to ground. A table showing the necessary R_T value for a desired switching frequency is shown in Table 1.

The switching frequency selected determines the efficiency, solution size, and input voltage range for the desired frequency. High frequency operation permits the use of

smaller inductor and capacitor values which reduces the overall solution size. However, as the switching frequency increases, efficiency decreases as well as the input voltage range for constant frequency operation.

Table 1. SW Frequency vs R_T Value

FREQUENCY (kHz)	R_{RT} (k Ω)
100	187
200	60.4
300	35.7
400	25.5
500	19.6
600	15.8
700	13.3
800	11.5
900	10
1000	8.66

Switching Frequency and Input Voltage Range

Once the switching frequency has been determined, the input voltage range for fixed frequency operation of the regulator can be determined.

The minimum input voltage for fixed frequency operation is determined by either the V_{IN} undervoltage lockout, or the following equation:

$$V_{IN(MIN)} = \frac{V_{OUT} + V_{SW(BOT)}}{1 - f_{SW} \cdot t_{OFF(MIN)}} - V_{SW(BOT)} + V_{SW(TOP)}$$

where V_{OUT} is the output voltage, $V_{SW(TOP)}$ and $V_{SW(BOT)}$ are the internal switch drops ($\sim 0.775V$, $\sim 0.550V$, respectively at maximum load), f_{SW} is the switching frequency (set by R_T), and $t_{OFF(MIN)}$ is the minimum switch off-time (see the Electrical Characteristics).

If the input voltage falls below $V_{IN(MIN)}$ (dropout mode), the LT8631 will automatically reduce the switching frequency from the programmed value to obtain the highest possible output voltage. The lower limit on the switching frequency in dropout mode is determined by the boost threshold. When the voltage between the BST and SW pins is less than the boost threshold, a minimum off-time pulse is generated to recharge the boost capacitor.

APPLICATIONS INFORMATION

The maximum input voltage for fixed frequency operation is determined by either the 100V maximum input voltage, or the following equation:

$$V_{IN(MAX)} = \frac{V_{OUT} + V_{SW(BOT)}}{t_{ON(MIN)} \cdot f_{SW}} - V_{SW(BOT)} + V_{SW(TOP)}$$

where V_{IN} is the typical input voltage, V_{OUT} is the output voltage, $V_{SW(TOP)}$ and $V_{SW(BOT)}$ are the internal switch drops (~0.775V, ~0.550V, respectively at maximum load) and $t_{ON(MIN)}$ is the minimum top switch on-time (see the Electrical Characteristics).

If the input voltage rises above $V_{IN(MAX)}$, the LT8631 will automatically reduce the switching frequency from the programmed value to maintain output regulation.

Inductor Selection and Maximum Output Current

A good first choice for the inductor value is:

$$L = \frac{V_{OUT} + V_{SW(BOT)}}{0.6 \cdot f_{SW}}$$

where f_{SW} is the switching frequency in MHz, V_{OUT} is the output voltage, and $V_{SW(BOT)}$ is the bottom switch drop (~0.550V) and L is the inductor value in μ H.

The inductor must be chosen with an RMS current rating that is greater than the maximum expected output load of the application. In addition, the saturation current (typically labeled ISAT) rating of the inductor must be higher than the load current plus 1/2 of the inductor ripple current:

$$I_{L(PEAK)} = I_{LOAD(MAX)} + 1/2 \Delta I_L$$

where ΔI_L is the inductor ripple current and $I_{LOAD(MAX)}$ is the maximum output load for a given application.

The peak-to-peak ripple current in the inductor can be calculated as follows:

$$\Delta I_L = \frac{V_{OUT}}{L \cdot f_{SW}} \cdot \left(1 - \frac{V_{OUT}}{V_{IN(MAX)}} \right)$$

where f_{SW} is the switching frequency in MHz and L is the value of the inductor in μ H. Therefore, the maximum output current that the LT8631 will deliver depends on the switch current limit, the inductor value, and the input and output

voltages. The inductor value may have to be increased if the inductor ripple current does not allow sufficient maximum current ($I_{OUT(MAX)}$) given the switching frequency and maximum input voltage used in the desired application.

Overload or short-circuit conditions can cause the inductor current to exceed the LT8631's peak current limit in less than the typical minimum on-time ($t_{ON(MIN)}$) of 100ns. Once the LT8631's typical peak current limit (I_{limpk}) of 2A is exceeded, it will not switch on until the current in the inductor has dropped below the peak current limit. If the loaded/shorted condition still exists when the LT8631 resumes switching, the maximum inductor current will be greater than the LT8631 peak current and at worst case will be:

$$I_{L(MAX)} = \frac{V_{IN(MAX)}}{L} \cdot t_{ON(MIN)} + I_{limpk}$$

The LT8631 safely tolerates this condition. However, if this condition can occur, the ISAT rating of the inductor should be increased from $I_{L(PEAK)}$ to $I_{L(MAX)}$.

The optimum inductor for a given application may differ from the one indicated by this design guide. A larger value inductor provides a higher maximum load current and reduces the output voltage ripple. For applications requiring smaller load currents, the value of the inductor may be lower and the LT8631 may operate with higher ripple current. This allows use of a physically smaller inductor, or one with a lower DCR resulting in higher efficiency. Be aware that low inductance may result in discontinuous mode operation, which further reduces maximum load current.

For more information about maximum output current and discontinuous operation, see Linear Technology's Application Note 44.

Finally, for duty cycles greater than 50% ($V_{OUT}/V_{IN} > 0.5$), a minimum inductance is required to avoid subharmonic oscillation. See Application Note 19.

Input Capacitor Selection

Bypass the LT8631 input with a 2.2 μ F or higher ceramic capacitor of X7R or X5R type placed as close as possible to the V_{IN} pin and ground. Y5V types have poor perfor-

APPLICATIONS INFORMATION

mance over temperature and applied voltage, and should not be used. Note that larger input capacitance is required when a lower switching frequency is used. If the input power source has high impedance, or there is significant inductance due to long wires or cables, additional bulk capacitance may be necessary. This can be provided with a low performance electrolytic capacitor.

A word of caution regarding the use of ceramic capacitors at the input. A ceramic input capacitor can combine with stray inductance to form a resonant tank circuit. If power is applied quickly (for example, by plugging the circuit into a live power source) this tank can ring, doubling the input voltage and damaging the LT8631. The solution is to either clamp the input voltage or dampen the tank circuit by adding a lossy capacitor in parallel with the ceramic capacitor. For details, see Application Note 88.

Output Capacitor Selection

The output capacitor has two essential functions. Along with the inductor, it filters the square wave generated by the LT8631 to produce the DC output. In this role it determines the output ripple, thus low impedance at the switching frequency is important. The second function is to store energy in order to satisfy transient loads and stabilize the LT8631's control loop. Since the LT8631 uses current mode control, it does not require the presence of output capacitor series resistance (ESR) for stability. Low ESR or ceramic capacitors should be used to achieve very low output ripple and small circuit size.

A 47 μ F, X5R or X7R ceramic capacitor with a voltage rating greater than the desired output voltage is an excellent first choice for most applications. The 47 μ F output capacitor will provide low output ripple with good transient response. Increasing the value will reduce the output voltage ripple and improve transient response, but may increase application cost and require more board space. Decreasing the value may save cost and board space but will increase output voltage ripple, degrade transient performance, and may cause loop instability. Increasing or decreasing the output capacitor may require increasing or decreasing the 4.7pF feedforward capacitor placed between the V_{OUT} and FB pins to optimize transient response. See the Typical Ap-

plications section in the data sheet for suggested output and feedforward capacitor values.

Note that even X5R and X7R type ceramic capacitors have a DC bias effect which reduces their capacitance when a DC voltage is applied. It is not uncommon for capacitors offered in the smallest case sizes to lose more than 50% of their capacitance when operated near their rated voltage. As a result it is sometimes necessary to use a larger capacitance value, larger case size, or use a higher voltage rating in order to realize the intended capacitance value. Consult the manufacturer's data for the capacitor you select to be assured of having the necessary capacitance for the application.

Ceramic Capacitors

Ceramic capacitors are small, robust, and have very low ESR. However, ceramic capacitors can cause problems when used with the LT8631 due to their piezoelectric nature. When in Burst Mode operation, the LT8631's switching frequency depends on the load current, and at very light loads the LT8631 can excite the ceramic capacitor at audio frequencies, generating audible noise. Since the LT8631 operates at a lower current limit during Burst Mode operation, the noise is typically very quiet to the casual ear. If this noise is unacceptable, use a high performance tantalum or electrolytic capacitor at the output. Low noise ceramic capacitors are also available.

Enable Pin

The LT8631 is in shutdown when the EN/UV pin is low and active when the pin is high. The rising threshold of the EN/UV comparator is 1.19V, with 17mV of hysteresis. The EN/UV pin can be tied to V_{IN} if the shutdown feature is not used, or tied to a logic level if shutdown control is required.

Adding a resistor divider from V_{IN} to EN/UV programs the LT8631 to regulate the output only when V_{IN} is above a desired voltage (see the Block Diagram). Typically, the EN/UV threshold is used in situations where the supply is current limited, or has a relatively high source resistance. A switching regulator draws constant power from the source, so source current increases as source voltage drops. This

APPLICATIONS INFORMATION

looks like a negative resistance load to the source and can cause the source to current limit or latch low under low source voltage conditions. The EN/UV threshold prevents the regulator from operating at source voltages where the problems might occur. This threshold can be adjusted by setting the values R3 and R4 such that they satisfy the following equation:

$$V_{\text{EN THRESHOLD}} = \left(\frac{R3}{R4} + 1 \right) \cdot 1.19\text{V}$$

where the LT8631 will remain off until V_{IN} is above the EN/UV threshold. Due to the comparator's hysteresis, switching will not stop until the input falls slightly below the threshold voltage.

When operating in Burst Mode operation for light load currents, the current through the EN/UV resistor network can easily be greater than the supply current consumed by the LT8631. Therefore, the EN/UV resistors should be large to minimize their effect on efficiency at low loads.

INTV_{CC} Regulator

An internal low dropout (LDO) regulator produces the 3V supply from V_{IN} that powers the drivers and the internal bias circuitry. The INTV_{CC} can supply enough current for the LT8631's circuitry and must be bypassed to ground with a minimum of 2.2μF ceramic capacitor. Good bypassing is necessary to supply the high transient currents required by the power MOSFET gate drivers. To improve efficiency, the internal regulator draws power from the V_{OUT} pin when the output voltage is 3.5V or higher. If the V_{OUT} pin is below 3.5V, the internal regulator will consume current from V_{IN} . Applications with high input voltage and high switching frequency where the internal regulator pulls current from V_{IN} will increase die temperature because of the higher power dissipation across the regulator. Do not connect an external load to the INTV_{CC} pin.

Soft-Start and Output Voltage Tracking

The LT8631 regulates its output to the lowest voltage present at either the TR/SS pin or an internal 0.808V reference. A capacitor from the TR/SS pin to ground is charged by an internal 4.5μA current source resulting in a

linear output ramp from 0V to the regulated output whose duration is given by:

$$T_{\text{RAMP}} = \frac{C_{\text{TR/SS}} \cdot 0.808\text{V}}{4.5\mu\text{A}}$$

At power-up, a reset signal (POR) sets the soft-start latch and discharges the TR/SS pin with to approximately 0V to ensure proper start-up. The TR/SS pin has a maximum current sink capability 230μA. If the TR/SS pin is used to as a track function for an external voltage, the maximum sink current must not be exceeded during startup. Exceeding the maximum TR/SS sink current will inhibit operation.

When the TR/SS pin is fully discharged, the latch is reset and the internal 4.5μA current source starts to charge the TR/SS pin. When the TR/SS pin voltage is below ~50mV, the V_C pin is pulled low which disables switching.

As the TR/SS pin voltage rises above 50mV, the V_C pin is released and the output voltage is regulated to the TR/SS voltage. When the TR/SS pin voltage exceeds the internal 808mV reference, the output is regulated to the reference. The TR/SS pin voltage will continue to rise to ~3V.

The soft-start latch is set during several fault conditions: EN/UV pin is below 1.19V, INTV_{CC} has fallen too low, V_{IN} is too low, or thermal shutdown. Once the latch is set, the TR/SS pin will discharge to ~0V and a new startup sequence will begin.

If the load exceeds the maximum output switch current, the output will start to drop causing the internal V_C clamp to be activated. As long as the V_C node is clamped, the TR/SS pin will be discharged. As a result, the output will be regulated to the highest voltage that the maximum output current can support. For example, if the output on the front page application is loaded by 2Ω the TR/SS pin will drop to 0.48V, regulating the output at 3V. Once the overload condition is removed, the output will soft-start from the temporary voltage level to the normal regulation point.

Since the TR/SS pin is pulled up to the 3V rail and has to discharge to 0.808V before taking control of regulation, momentary overload conditions will be tolerated without a sort-start recovery. The typical time before the TR/SS

APPLICATIONS INFORMATION

pin takes control is:

$$T_{TR/SS(CONTROL)} = \frac{C_{TR/SS} \cdot 2.2V}{30\mu A}$$

Output Power Good

When the LT8631's output voltage is within the $\pm 7.5\%$ window of the regulation point (V_{FBREF}), typically 0.74V to 0.86V, the output voltage is considered good and the open-drain PG pin is a high impedance node, and is typically pulled high with an external resistor. Otherwise, the internal pull-down device will pull the PG pin low. To prevent glitching both the upper and lower thresholds include 1.9% of hysteresis.

The PG pin is also actively pulled low during several fault conditions: EN/UV pin is below 1.19V, V_{IN} undervoltage, or thermal shutdown.

Synchronization

To select low ripple Burst Mode operation, tie the SYNC/MODE pin below 1V (this can be ground or a logic low output). To synchronize the LT8631 oscillator to an external frequency connect a square wave (with a 20% to 80% duty cycle) to the SYNC/MODE pin. The square wave amplitude should have valleys that are below 1V and peaks above 2V.

The LT8631 will not enter Burst Mode operation at low output loads while synchronized to an external clock, but instead will pulse skip to maintain regulation. The LT8631 may be synchronized over a 100kHz to 1MHz range. The RT resistor should be chosen to set the LT8631 switching frequency 10% below the lowest synchronization input. For example, if the synchronization signal will be 500kHz, the RT should be selected for 450kHz. The slope compensation is set by the RT value, while the minimum slope compensation required to avoid subharmonic oscillations is established by the inductor size, input voltage, and output voltage. Since the synchronization frequency will not change the slopes of the inductor current waveform, if the inductor is large enough to avoid subharmonic oscillations at the frequency set by RT, then the slope compensation will be sufficient for all synchronization frequencies.

For some applications it is desirable for the LT8631 to

operate in pulse-skipping mode. In pulse-skipping mode, the full switching frequency is reached at a slightly lower output load than in Burst Mode operation at the expense of increased quiescent current. To enable pulse-skipping mode, the SYNC/MODE pin is tied high either to a logic output or to the INTV_{CC} pin.

The LT8631 does not operate in forced continuous mode regardless of SYNC/MODE signal. Connect the SYNC/MODE pin to GND if it is not used in the application.

Shorted and Reverse Input Protection

If the inductor is chosen so that it won't saturate excessively, the LT8631 will tolerate a shorted output.

There is another situation to consider in systems where the output will be held high when the input to the LT8631 is absent. This may occur in battery charging applications or in battery back-up systems where a battery or some other supply is diode ORed with the LT8631's output. If the V_{IN} pin is allowed to float and the EN/UV pin is held high (either by a logic signal or because it is tied to V_{IN}), then the LT8631's internal circuitry will pull its quiescent current through its SW pin. This is acceptable if the system can tolerate $\sim 6mA$ in this state. If the EN pin is grounded the SW pin current will drop to near $5\mu A$. However, if the V_{IN} pin is grounded while the output is held high, regardless of EN, parasitic body diodes inside the LT8631 can pull current from the output through the SW pin and the V_{IN} pin. Figure 4 shows a connection of the V_{IN} and EN/UV pins that will allow the LT8631 to run only when the input voltage is present and that protects against a shorted or reversed input.

PCB Layout

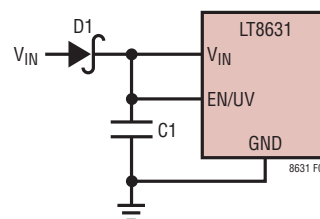

Figure 4. Reverse Input Voltage Protection

APPLICATIONS INFORMATION

For proper operation and minimum EMI, care must be taken during printed circuit board layout. Figure 5 shows the recommended component placement with trace, ground plane, and via locations. Note that large, switched currents flow in the LT8631's V_{IN} pin and the input capacitor (C1). The loop formed by the input capacitor should be as small as possible by placing the capacitor adjacent to the V_{IN} pin and ground plane. When using a physically large input capacitor the resulting loop may become too large in which case using a small case/value capacitor placed close to the V_{IN} pin and ground plane plus a larger capacitor further away is preferred. These components, along with the inductor and output capacitor, should be placed on the same side of the circuit board, and their connections should be made on that layer. Place a local, unbroken ground plane under the application circuit on the layer closest to the surface layer. The SW and BST nodes should

be as small as possible. Finally, keep the FB and RT nodes small so that the ground traces will shield them from the SW and BST nodes. The exposed pad on the bottom of the package must be soldered to ground so that the pad is connected to ground electrically and also acts as a heat sink thermally. To keep thermal resistance low, extend the ground plane as much as possible, and add thermal vias under and near the LT8631 to additional ground planes within the circuit board and on the bottom side.

High Temperature Considerations

For higher ambient temperatures, care should be taken in the layout of the PCB to ensure good heat sinking of the LT8631. The exposed pad on the bottom of the package must be soldered to a ground plane. This ground should be tied to large copper layers below with thermal vias; these layers will spread heat dissipated by the LT8631.

Placing additional vias can reduce thermal resistance

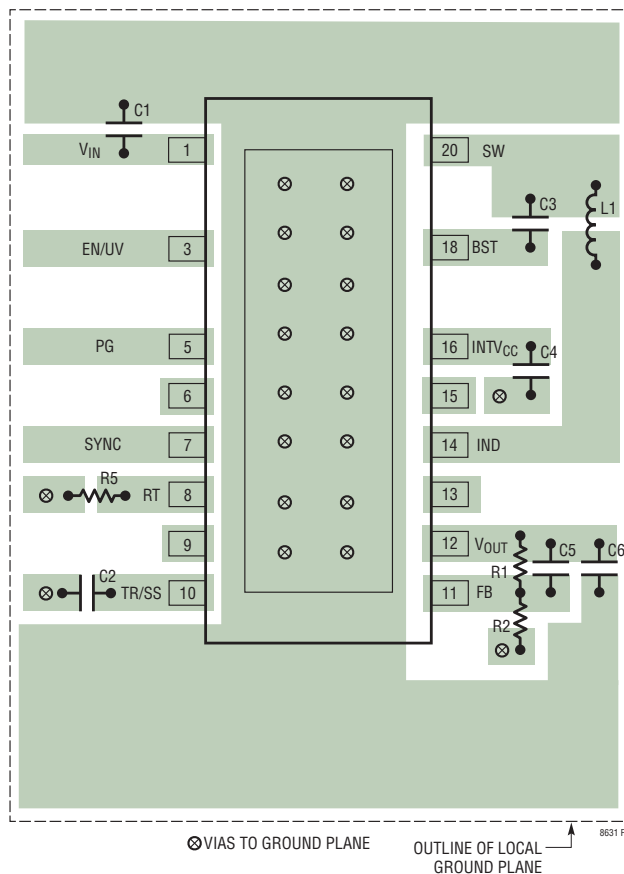

Figure 5. Recommended PCB Layout for the LT8631

APPLICATIONS INFORMATION

further. The maximum load current should be derated as the ambient temperature approaches the maximum junction rating. Power dissipation within the LT8631 can be estimated by calculating the total power loss from an efficiency measurement and subtracting the inductor loss. The die temperature is calculated by multiplying the LT8631 power dissipation by the thermal resistance from junction to ambient.

If safe junction temperature is exceeded, the LT8631 will shutdown and restart with a POR sequence.

External Schottky Catch Diode

For high temperature, high input voltage and high output load applications, adding a Schottky catch diode (Figure 6), will lower the LT8631 junction temperature by increasing efficiency (Figure 7). Use a low leakage Schottky diode rated greater than 2A with a reverse voltage greater than the maximum input voltage for the application. A complete application circuit with the additional Schottky can be found in the Typical Applications section.

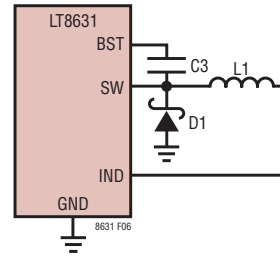

Figure 6. External Schottky Catch Diode

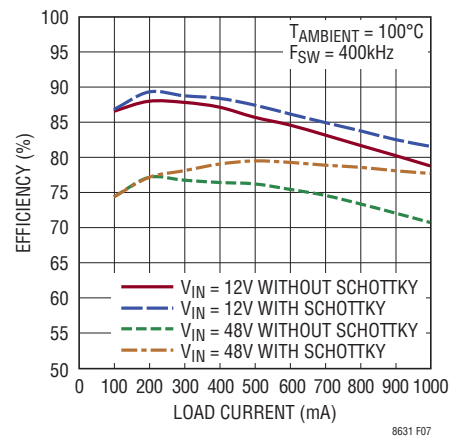
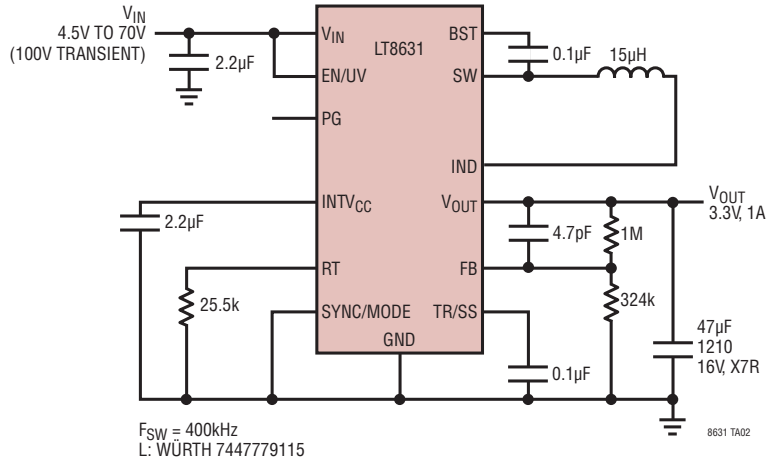

Figure 7. LT8631 Efficiency with/without External Schottky

TYPICAL APPLICATIONS

400kHz, 3.3V, 1A Step-Down Converter



1MHz, 3.3V, 1A Step-Down Converter

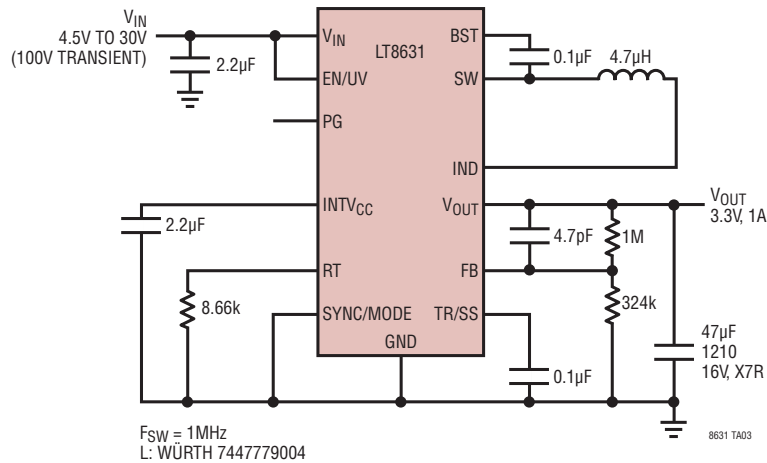

TYPICAL APPLICATIONS

1MHz, 5V, 1A Step-Down Converter

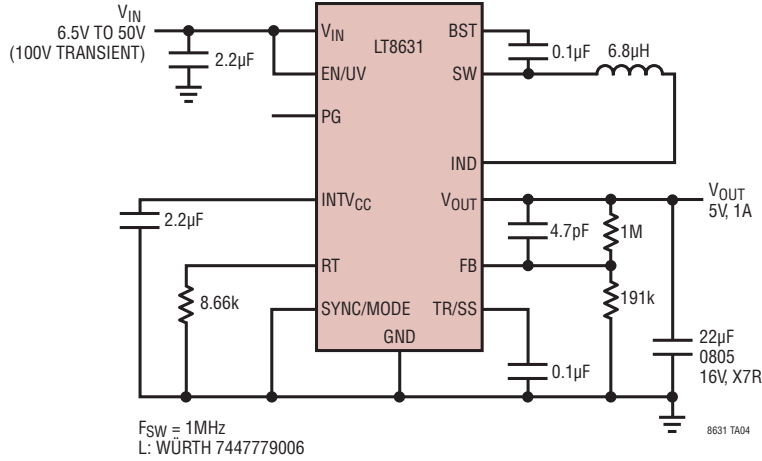

5V, Low Ripple 1A Step-Down Converter

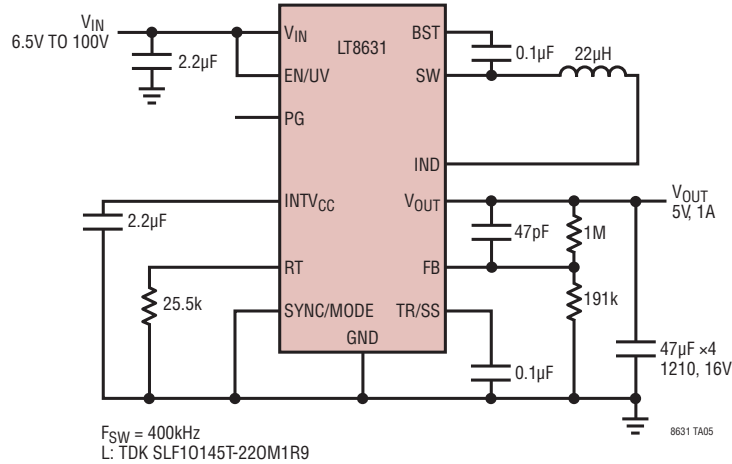

TYPICAL APPLICATIONS

200kHz, 1.8V, 1A Step-Down Converter

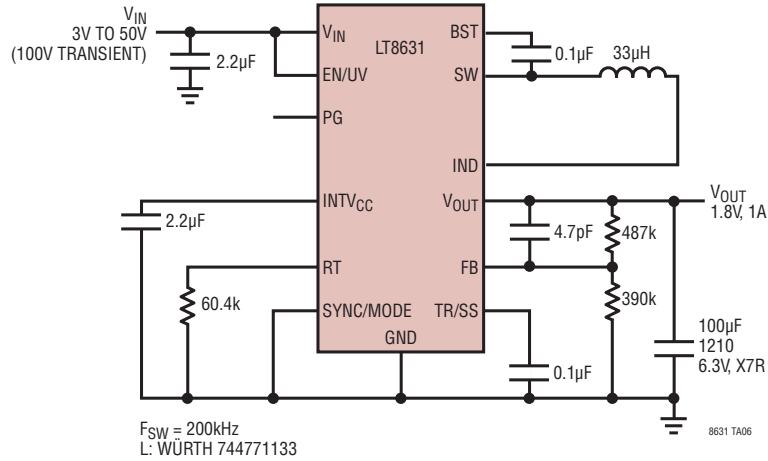

1MHz, 24V, 0.5A Step-Down Converter

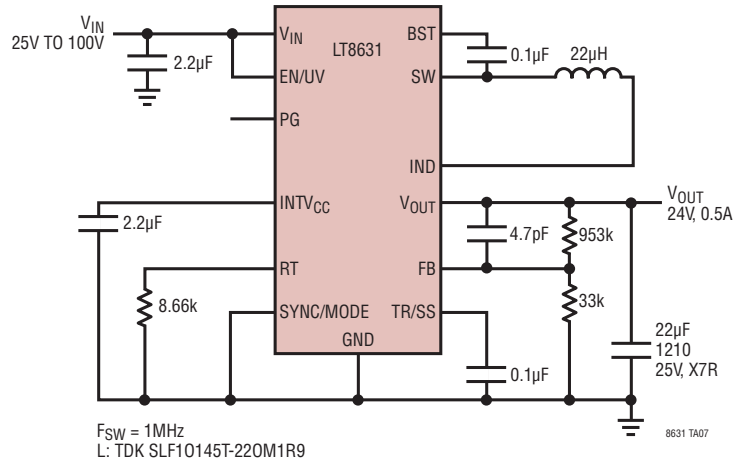

TYPICAL APPLICATIONS

400kHz, 12V/250mA, 3.3V/2.5A Dual Step-Down Converter

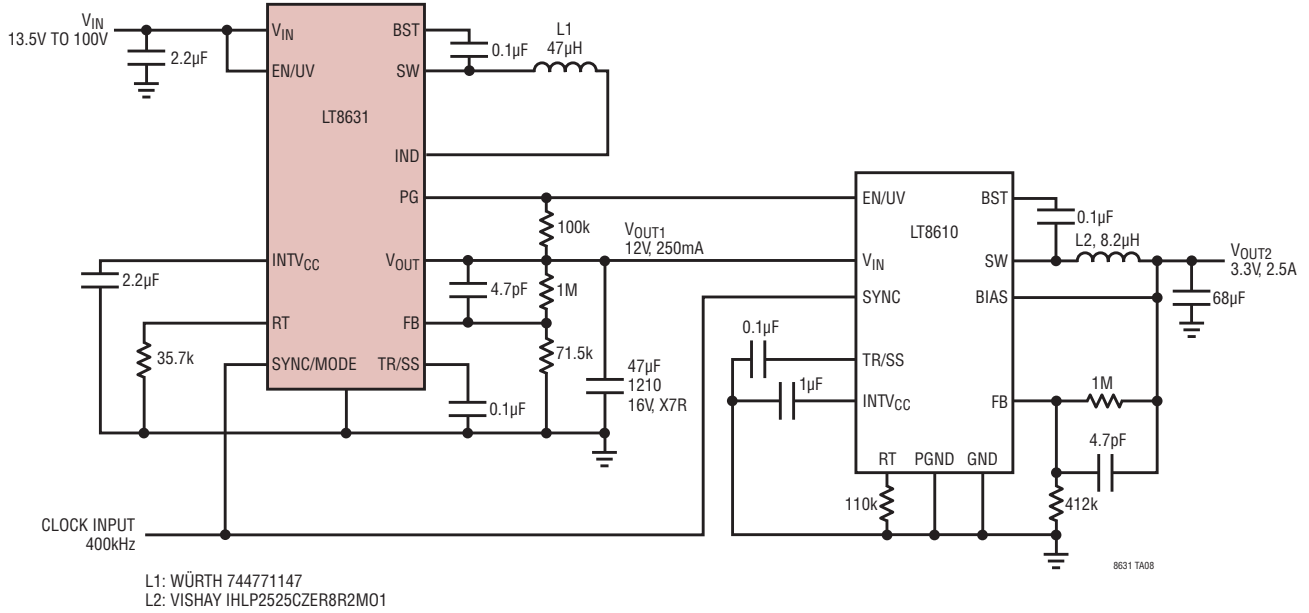

400kHz, 5V/1A High Voltage/Temperature Step-Down Converter

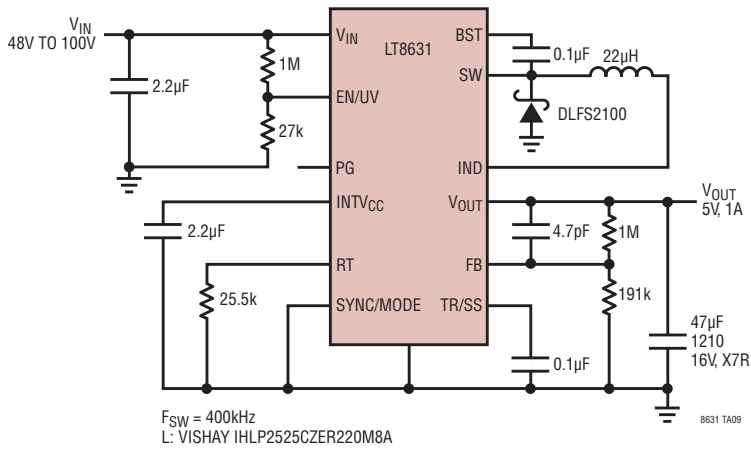

PACKAGE DESCRIPTION

Please refer to <http://www.linear.com/product/LT8631#packaging/> for the most recent package drawings.

FE Package
Variation: FE20(16)
20-Lead Plastic TSSOP (4.4mm)
 (Reference LTC DWG # 05-08-1924 Rev 0)
Exposed Pad Variation CB

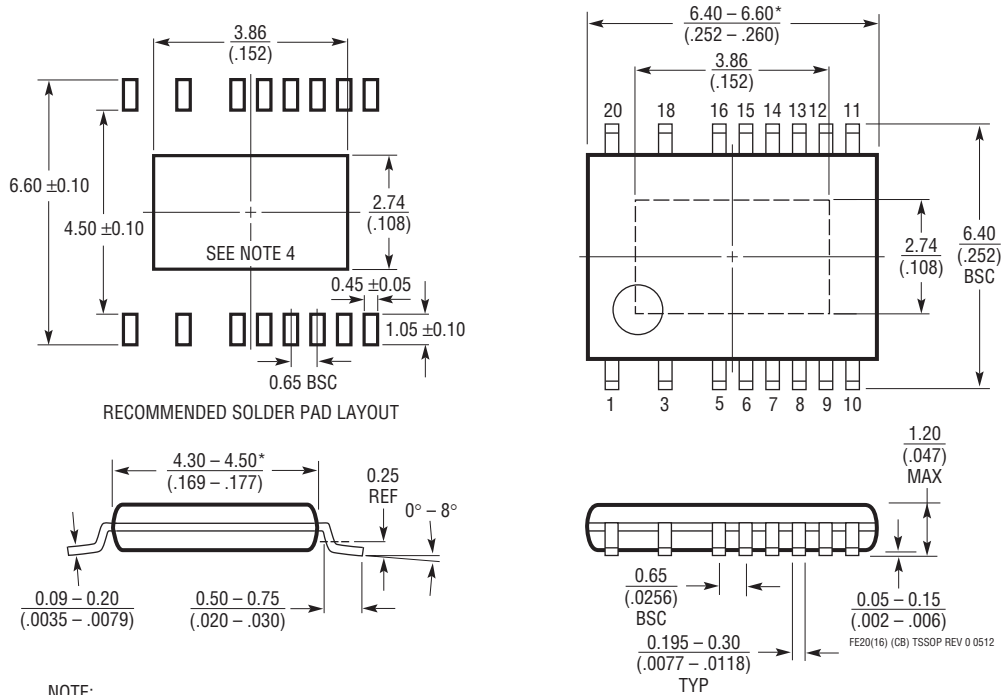

- NOTE:
1. CONTROLLING DIMENSION: MILLIMETERS
 2. DIMENSIONS ARE IN $\frac{\text{MILLIMETERS}}{\text{(INCHES)}}$
 3. DRAWING NOT TO SCALE
 4. RECOMMENDED MINIMUM PCB METAL SIZE FOR EXPOSED PAD ATTACHMENT
- *DIMENSIONS DO NOT INCLUDE MOLD FLASH. MOLD FLASH SHALL NOT EXCEED 0.150mm (.006") PER SIDE

REVISION HISTORY

REV	DATE	DESCRIPTION	PAGE NUMBER
A	11/16	Corrected Part Marking to LT8631FE	2
B	9/17	Clarified EN/UV Voltage Hysteresis, Quiescent Current, Minimum On-Time and Switch Pin Leakage parameters Clarified formulas	3 14

Information furnished by Linear Technology Corporation is believed to be accurate and reliable. However, no responsibility is assumed for its use. Linear Technology Corporation makes no representation that the interconnection of its circuits as described herein will not infringe on existing patent rights.

TYPICAL APPLICATION

12V, 1A, Step-Down Converter

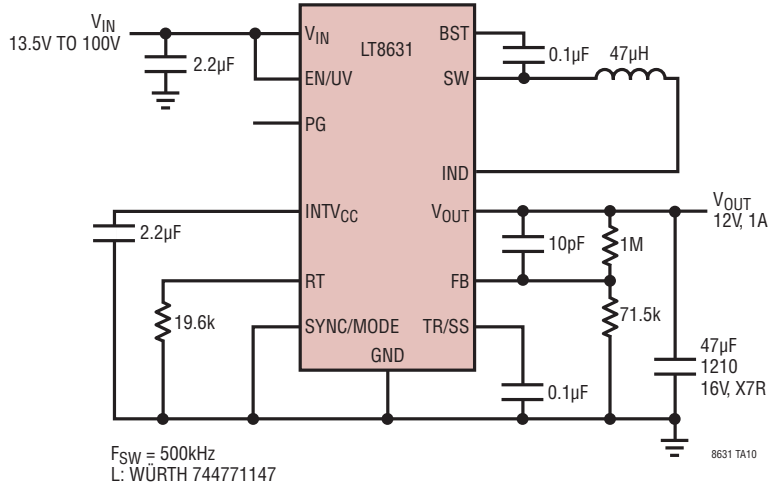

RELATED PARTS

PART NUMBER	DESCRIPTION	COMMENTS
LT8620	65V, 2A, Synchronous Step-Down DC/DC Converter	V_{IN} : 3.4V to 65V, $V_{OUT(MIN)}$ = 0.97V, I_Q = 2.5µA, I_{SD} < 1mA, MSOP-16E and 3mm × 5mm QFN Packages
LT3991	55V, 1.2A, Micropower Step-Down DC/DC Converter with I_Q = 2.8µA	V_{IN} : 4.2V to 55V, $V_{OUT(MIN)}$ = 1.20V, I_Q = 2.8µA, I_{SD} < 1µA, 3mm × 3mm DFN-10 and MSOP-10E Packages
LT8610	42V, 2.5A, Synchronous Micropower Step-Down DC/DC Converter with I_Q = 2.5µA	V_{IN} : 3.4V to 42V, $V_{OUT(MIN)}$ = 0.97V, I_Q : 2.5µA, I_{SD} : <1µA, TSSOP16E
LT8614	42V, 4A, Synchronous Micropower Step-Down DC/DC Converter with I_Q = 1.7µA	V_{IN} : 3.4V to 42V, $V_{OUT(MIN)}$ = 0.97V, I_Q : 1.7µA, I_{SD} : <1µA, QFN-18
LTC®3630A	76V, 500mA Synchronous Step-Down DC/DC Converter	V_{IN} : 4V to 76V, $V_{OUT(MIN)}$ = 0.8V, I_Q = 12µA, I_{SD} = 3µA, 3mm × 5mm DFN-16, MSOP-16(12)E
LTC3637	76V, 1A Nonsynchronous Step-Down DC/DC Converter	V_{IN} : 4V to 76V, $V_{OUT(MIN)}$ = 0.8V, I_Q = 12µA, I_{SD} = 3µA, 3mm × 5mm DFN-16, MSOP-16(12)E
LTC3638	140V, 250mA Synchronous Step-Down DC/DC Converter	V_{IN} : 4V to 140V, $V_{OUT(MIN)}$ = 0.8V, I_Q = 12µA, I_{SD} < 1mA, MSOP-16E Package
LTC3639	150V, 100mA Synchronous Step-Down Regulator	V_{IN} : 4V to 150V, $V_{OUT(MIN)}$ = 0.8V, I_Q = 12µA, I_{SD} = 1.4µA, MSOP-16(12)E

Looking for pricing, stock, or lifecycle information?

Click below to explore more details on WIN SOURCE:

 [View LT8631EFE#PBF on WIN SOURCE](#)

 [Linear Technology](#) Information

Optimize Your Supply Chain with WIN SOURCE Solutions

-  Global Sourcing Solution
-  Obsolete Management
-  Cost Control Management
-  Shortage Management
-  Alternative Solution
-  Excess Inventory Management