



**THE DATASHEET OF
LTC1064-2CSW#TRPBF**



Low Noise, High Frequency, 8th Order Butterworth Lowpass Filter

FEATURES

- 8th Order Filter in a 14-Pin Package
- 140kHz Maximum Corner Frequency
- No External Components
- 50:1 and 100:1 Clock to Cutoff Frequency Ratio
- $80\mu\text{V}_{\text{RMS}}$ Total Wideband Noise
- 0.03% THD or Better
- Operates from $\pm 2.37\text{V}$ to $\pm 8\text{V}$ Power Supplies

APPLICATIONS

- Antialiasing Filters
- Smoothing Filters
- Tracking High Frequency Lowpass Filters

DESCRIPTION

The LTC[®]1064-2 is a monolithic 8th order lowpass Butterworth filter, which provides a maximally flat pass-band. The attenuation slope is -48dB/octave and the maximum attenuation is in excess of 80db. An external TTL or CMOS clock programs the filter's cutoff frequency. The clock to cutoff frequency ratio is 100:1 (Pin 10 at V^-) or 50:1 (Pin 10 at V^+). The maximum cutoff frequency is 140kHz. No external components are needed.

The LTC1064-2 features low wideband noise and low harmonic distortion even for input voltages up to 3V_{RMS} . In fact the LTC1064-2 overall performance competes with equivalent multiple op amp RC active realizations. The LTC1064-2 is available in a 14-pin DIP or 16-pin surface mounted SW package. The LTC1064-2 is fabricated using LTC's enhanced analog CMOS Si-gate process.

The LTC1064-2 is pin compatible with the LTC1064-1.

LT, LTC and LT are registered trademarks of Linear Technology Corporation.

TYPICAL APPLICATION

**8th Order Clock Sweeable
Lowpass Butterworth Filter**

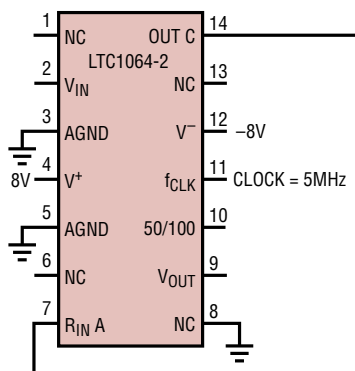

NOTE: THE POWER SUPPLIES SHOULD BE BYPASSED BY A $0.1\mu\text{F}$ CAPACITOR CLOSE TO THE PACKAGE. THE NC PINS 1, 6, 8, AND 13 SHOULD BE PREFERABLY GROUNDING.

Measured Frequency Response

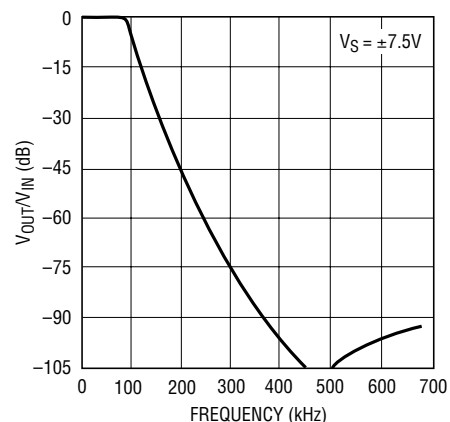

1064-2 TA01b

LTC1064-2

ABSOLUTE MAXIMUM RATINGS (Note 1)

Total Supply Voltage (V^+ to V^-)	16.5V	Operating Temperature Range	
Power Dissipation	400mW	LTC1064-2M (OBSOLETE)	-55°C to 125°C
Storage Temperature Range	-65°C to 150°C	LTC1064-2C	-40°C to 85°C
Lead Temperature (Soldering, 10 sec)	300°C		

PACKAGE/ORDER INFORMATION

<p>TOP VIEW</p> <p>N PACKAGE 14-LEAD PDIP $T_{JMAX} = 150^{\circ}\text{C}$, $\theta_{JA} = 110^{\circ}\text{C/W}$</p>	<p>ORDER PART NUMBER</p> <p>LTC1064-2CN</p>	<p>TOP VIEW</p> <p>SW PACKAGE 16-LEAD PLASTIC (WIDE) SO $T_{JMAX} = 150^{\circ}\text{C}$, $\theta_{JA} = 130^{\circ}\text{C/W}$</p>	<p>ORDER PART NUMBER</p> <p>LTC1064-2CSW</p>
<p>J PACKAGE 14-LEAD CERDIP</p> <p>OBSOLETE PACKAGE Consider the N14 Package for Alternate Source</p>	<p>LTC1064-2MJ LTC1064-2CJ</p>		

Consult LTC Marketing for parts specified with wider operating temperature ranges.

ELECTRICAL CHARACTERISTICS

The ● denotes the specifications which apply over the full operating temperature range, otherwise specifications are at $T_A = 25^{\circ}\text{C}$. $V_S = \pm 7.5\text{V}$, 100:1, $f_{CLK} = 2\text{MHz}$, $R_1 = 10\text{k}$, TTL clock input level unless otherwise specified.

PARAMETER	CONDITIONS	MIN	TYP	MAX	UNITS
Passband Gain (Note 2)	Referenced to 0dB, 1Hz to 1kHz	● -0.5		0.15	dB
Gain TempCo			0.0002		dB/°C
-3dB Frequency	100:1		20		kHz
	50:1		40		kHz
Gain at -3dB Frequency	Referenced to 0dB, $f_{IN} = 20\text{kHz}$	●	-3	-2.75	dB
Stopband Attenuation	At $1.5f_{-3dB}$, 50:1, $f_{IN} = 60\text{kHz}$	● -24	-27		dB
Stopband Attenuation	At $2f_{-3dB}$, 100:1, $f_{IN} = 40\text{kHz}$	● -44	-47		dB
Stopband Attenuation	At $3f_{-3dB}$, 100:1, $f_{IN} = 60\text{kHz}$		-74		dB
Stopband Attenuation	At $4f_{-3dB}$, 100:1, $f_{IN} = 80\text{kHz}$		-90		dB
Input Frequency Range	100:1	0		$< f_{CLK}/2$	kHz
	50:1	0		$< f_{CLK}$	kHz
Output Voltage Swing and Operating Input Voltage Range	$V_S = \pm 2.37\text{V}$	● ± 1.1			V
	$V_S = \pm 5\text{V}$	● ± 3.1			V
	$V_S = \pm 7.5\text{V}$	● ± 5.0			V
Total Harmonic Distortion	$V_S = \pm 5\text{V}$, Input = $1V_{RMS}$ at 1kHz		0.015		%
	$V_S = \pm 7.5\text{V}$, Input = $3V_{RMS}$ at 1kHz		0.03		%
Wideband Noise	$V_S = \pm 5\text{V}$, Input = GND 1Hz - 1.99MHz		80		μV_{RMS}
	$V_S = \pm 7.5\text{V}$, Input = GND 1Hz - 1.99MHz		90		μV_{RMS}

10642fa

ELECTRICAL CHARACTERISTICS The ● denotes the specifications which apply over the full operating temperature range, otherwise specifications are at $T_A = 25^\circ\text{C}$. $V_S = \pm 7.5\text{V}$, 100:1, $f_{\text{CLK}} = 2\text{MHz}$, $R_1 = 10\text{k}$, TTL clock input level unless otherwise specified.

PARAMETER	CONDITIONS	MIN	TYP	MAX	UNITS
Output DC Offset (Note 2)	$V_S = \pm 7.5\text{V}$		± 30	± 125	mV
Output DC Offset TempCo	$V_S = \pm 5\text{V}$		± 90		$\mu\text{V}/^\circ\text{C}$
Input Impedance		10	20		$\text{k}\Omega$
Output Impedance	$f_{\text{OUT}} = 10\text{kHz}$		2		Ω
Output Short-Circuit Current	Source/Sink		3/1		mA
Clock Feedthrough			200		μV_{RMS}
Maximum Clock Frequency	50% Duty Cycle, $V_S = \pm 5\text{V}$			5	MHz
	50% Duty Cycle, $T_A = 25^\circ\text{C}$, $V_S = \pm 7.5\text{V}$			7	MHz
Power Supply Current	$V_S = \pm 2.37\text{V}$, $f_{\text{CLK}} = 1\text{MHz}$	●	11	22	mA
	$V_S = \pm 5\text{V}$, $f_{\text{CLK}} = 1\text{MHz}$	●	14	23	mA
		●		26	mA
	$V_S = \pm 7.5\text{V}$, $f_{\text{CLK}} = 1\text{MHz}$	●	17	28	mA
		●		32	mA
Power Supply Voltage Range		●	± 2.37	± 8	V

Note 1: Absolute Maximum Ratings are those values beyond which the life of a device may be impaired.

Note 2: For tighter specifications please contact LTC Marketing.

TYPICAL PERFORMANCE CHARACTERISTICS

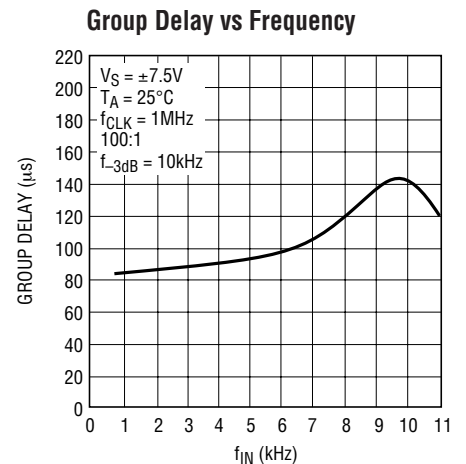
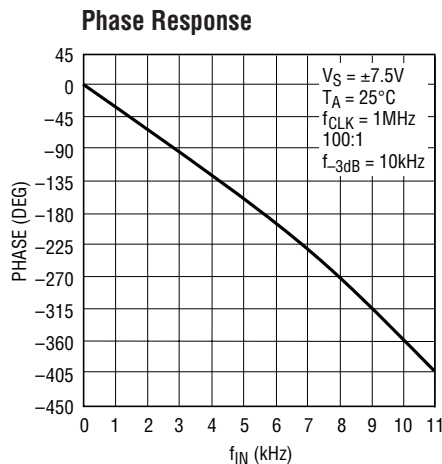
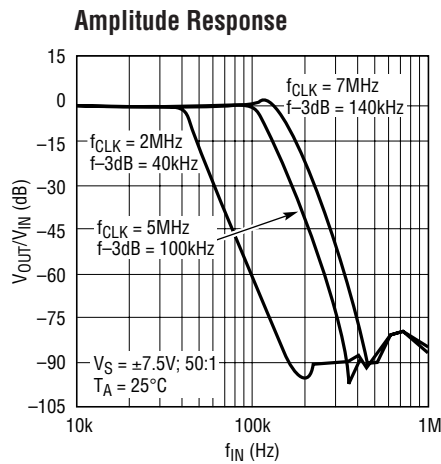

TYPICAL PERFORMANCE CHARACTERISTICS

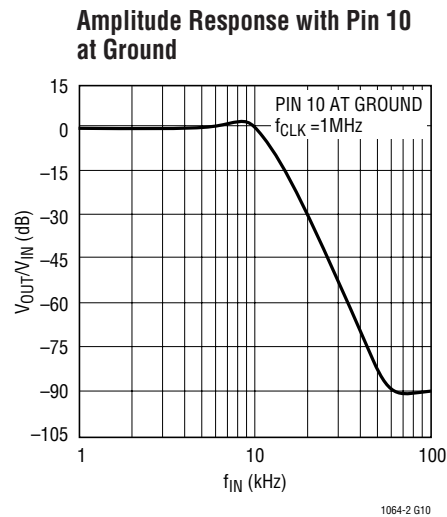
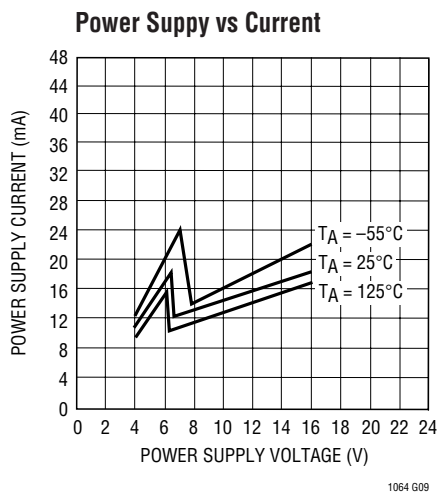
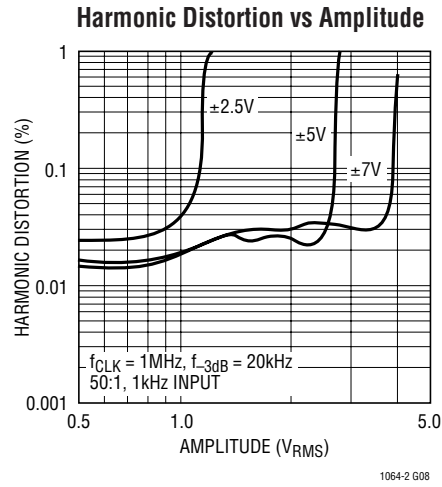
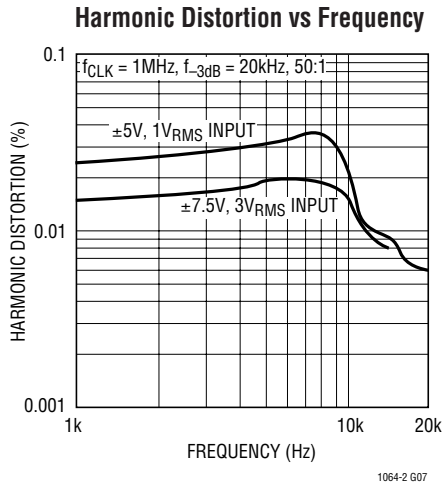
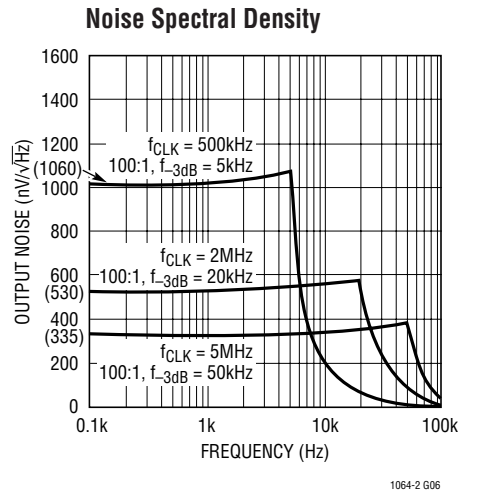
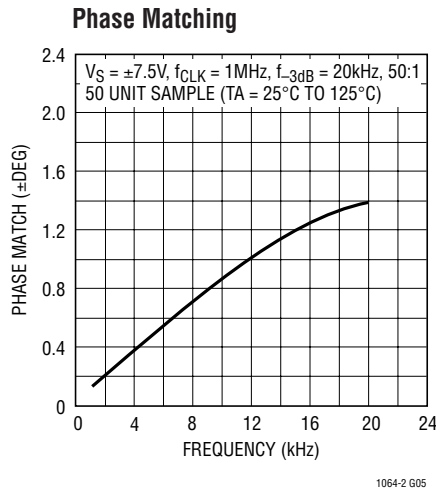
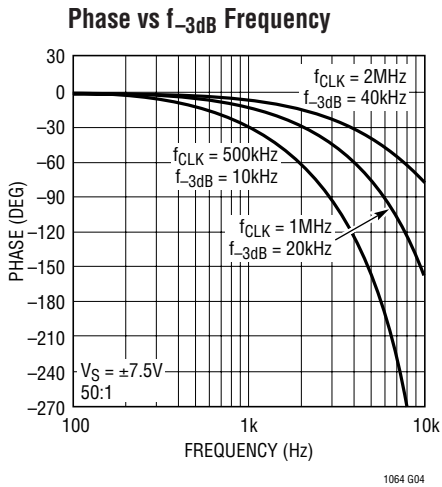

TYPICAL PERFORMANCE CHARACTERISTICS

**Table 1. Gain/Delay, $f_{-3dB} = 1\text{kHz}$,
LTC1064-2 Typical Response $V_S = \pm 5\text{V}$, $T_A = 25^\circ\text{C}$,
 $f_{CLK} = 50\text{kHz}$, Ratio = Pin 10 at V^+ (fltr 50:1)**

FREQUENCY (kHz)	GAIN (dB)	DELAY (ms)
0.200	-0.247	0.857
0.300	-0.270	0.872
0.400	-0.290	0.893
0.500	-0.300	0.929
0.600	-0.320	0.983
0.700	-0.370	1.071
0.800	-0.520	1.210
0.900	-1.200	1.364
1.000	-3.380	1.381
1.100	-7.530	1.192
1.200	-12.670	0.935

**Table 2. Gain, $f_{-3dB} = 1\text{kHz}$,
LTC1064-2 Typical Response $V_S = \pm 5\text{V}$, $T_A = 25^\circ\text{C}$,
 $f_{CLK} = 50\text{kHz}$, Ratio = Pin 10 at V^+ (fltr 50:1)**

FREQUENCY (kHz)	GAIN (dB)
0.500	-0.298
1.000	-3.380
1.500	-27.500
2.000	-47.200
2.500	-63.300
3.000	-75.190
3.500	-86.100
4.000	-95.310
4.500	-104.240
5.000	-109.650
5.500	-121.930
6.000	-123.920
6.500	-114.150
7.000	-116.990
7.500	-120.070
8.000	-113.470
8.500	-130.090
9.000	-114.770
9.500	-117.760

**Table 3. Gain/Delay, $f_{-3dB} = 1\text{kHz}$,
LTC1064-2 Typical Response $V_S = \pm 5\text{V}$, $T_A = 25^\circ\text{C}$,
 $f_{CLK} = 100\text{kHz}$, Ratio = Pin 10 at V^- (fltr 100:1)**

FREQUENCY (kHz)	GAIN (dB)	DELAY (ms)
0.200	-0.213	0.821
0.300	-0.240	0.837
0.400	-0.260	0.858
0.500	-0.280	0.893
0.600	-0.310	0.947
0.700	-0.370	1.034
0.800	-0.530	1.172
0.900	-1.200	1.325
1.000	-3.370	1.346
1.100	-7.500	1.158
1.200	-12.640	0.899

**Table 4. Gain, $f_{-3dB} = 1\text{kHz}$,
LTC1064-2 Typical Response $V_S = \pm 5\text{V}$, $T_A = 25^\circ\text{C}$,
 $f_{CLK} = 100\text{kHz}$, Ratio = Pin 10 at V^- (fltr 100:1)**

FREQUENCY (kHz)	GAIN (dB)
0.500	-0.279
1.000	-3.370
1.500	-27.500
2.000	-47.200
2.500	-62.300
3.000	-75.130
3.500	-86.090
4.000	-95.210
4.500	-103.030
5.000	-108.690
5.500	-114.830
6.000	-120.540
6.500	-114.750
7.000	-116.430
7.500	-120.790
8.000	-121.290
8.500	-119.970
9.000	-120.020
9.500	-125.170

TYPICAL PERFORMANCE CHARACTERISTICS

**Table 5. Gain, $f_{-3dB} = 20\text{kHz}$,
LTC1064-2 Typical Response $V_S = \pm 7.5\text{V}$, $T_A = 25^\circ\text{C}$,
 $f_{CLK} = 1\text{MHz}$, Ratio = Pin 10 at V^+ (fltr 50:1)**

FREQUENCY (kHz)	GAIN (dB)
10.000	-0.308
20.000	-3.350
30.000	-27.400
40.000	-47.100
50.000	-62.300
60.000	-74.890
70.000	-85.430
80.000	-95.070
90.000	-103.150
100.000	-108.700
110.000	-107.520
120.000	-108.030
130.000	-104.990
140.000	-106.090
150.000	-105.320

**Table 7. Gain Non-Butterworth Response (Pin 10 to GND),
LTC1064-2 Typical Response $V_S = \pm 5\text{V}$, $T_A = 25^\circ\text{C}$,
 $f_{CLK} = 100\text{kHz}$**

FREQUENCY (kHz)	GAIN (dB)
0.500	-0.012
1.000	1.240
1.500	-14.690
2.000	-28.600
2.500	-41.100
3.000	-52.500
3.500	-62.800
4.000	-71.500
4.500	-79.370
5.000	-86.730
5.500	-93.340
6.000	-99.350
6.500	-105.270
7.000	-113.270
7.500	-114.600
8.000	-114.010
8.500	-122.810
9.000	-122.980
9.500	-119.450

**Table 6. Gain, $f_{-3dB} = 140\text{kHz}$,
LTC1064-2 Typical Response $V_S = \pm 7.5\text{V}$, $T_A = 25^\circ\text{C}$,
 $f_{CLK} = 7\text{MHz}$, Ratio = Pin 10 at V^+ (fltr 50:1)**

FREQUENCY (kHz)	GAIN (dB)
50.00	-0.238
60.00	-0.140
70.00	0.050
80.00	0.350
90.00	0.810
100.00	1.450
110.00	2.110
120.00	1.830
130.00	-0.700
140.00	-4.840
150.00	-9.350
160.00	-13.690
170.00	-17.760
180.00	-21.600
190.00	-25.200
200.00	-28.500
210.00	-31.800
220.00	-34.800
230.00	-37.700
240.00	-40.500
250.00	-43.200
260.00	-45.700
270.00	-48.200
280.00	-50.500
290.00	-52.700
300.00	-54.900

PIN FUNCTIONS (Pin Numbers Refer to the 14-Pin Package)

NC (Pins 1, 6, 8 and 13): The “no connection” pins should be preferably grounded. These pins are not internally connected.

V_{IN}, V_{OUT} (Pins 2, 9): The input Pin 2 is connected to an 18k resistor tied to the inverting input of an op amp. Pin 2 is protected against static discharge. The device’s output, Pin 9, is the output of an op amp which can typically source/sink 3mA/1mA. Although the internal op amps are unity gain stable, driving long coax cables is not recommended.

When testing the device for noise and distortion, the output, Pin 9, should be buffered. (Figure 1) *The op amp power supply wire (or trace) should be connected directly to the power source. To eliminate switching transients from filter output, buffer filter output with a third order lowpass (Figure 5).*

AGND (Pins 3, 5): For dual supply operation these pins should be connected to a ground plane. For single supply operation both pins should be tied to one half supply, (Figure 3).

V⁺, V⁻ (Pins 4, 12): Should be bypassed with a 0.1μF capacitor to an adequate AGND. Low noise, nonswitching power supplies are recommended. *To avoid latchup when the power supplies exhibit high turn-on transients, a 1N5817 Schottky diode should be added from the V⁺ and V⁻ pins to ground (Figures 1, 2 and 3).*

R_{IN A}, OUT C (Pins 7, 14): A very short connection between Pin 7 and Pin 14 is recommended. This connection should be preferably done under the IC package. In a breadboard use a one inch, or less, shielded coaxial cable: the shield should be grounded. In a PC board, use a one inch trace or less; surround the trace by a ground plane.

50/100 (Pin 10): The DC level at this pin determines the ratio of clock frequency to the –3dB frequency of the filter. The ratio is 50:1 when Pin 10 is at V⁺ and 100:1 when Pin 10 is at V⁻. This pin should be bypassed with a 0.1μF capacitor to analog ground when it’s connected to V⁻ or V⁺ (Figure 1). See Tables 1 through 7 for typical gain and delay responses for the two ratios.

f_{CLK} (Pin 11): For ±5V supplies the logic threshold level is 1.4V. For ±8V and 0V to 5V supplies the logic threshold levels are 2.2V and 3V respectively. The logic threshold levels vary ±100mV over the full military temperature range. The recommended duty cycle of the input clock is 50% although for clock frequencies below 500kHz the clock “on” time can be as low as 200ns. The maximum clock frequency for ±5V supplies is 4MHz. For ±7V supplies and above, the maximum clock frequency is 7MHz. Do not allow the clock levels to exceed the power supplies. For single supply operation ≥6V use level shifting at Pin 11 with T²L levels (Figure 4).

TYPICAL APPLICATIONS

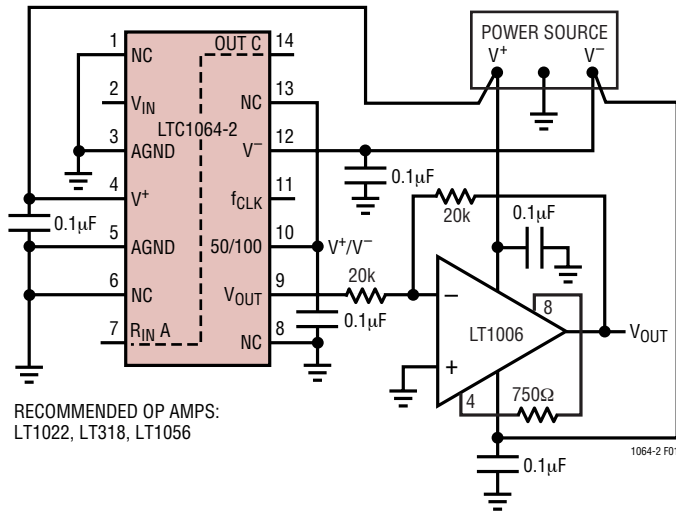

Figure 1. Buffering the Filter Output. The Buffer Op Amp Should Not Share the LTC1064-2 Power Lines.

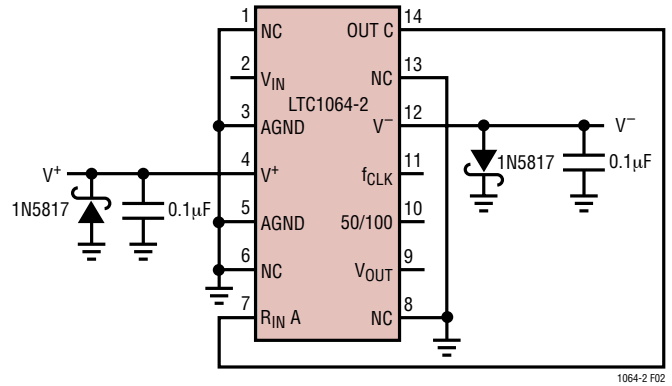

Figure 2. Using Schottky Diodes to Protect the IC from Transient Supply Reversal.

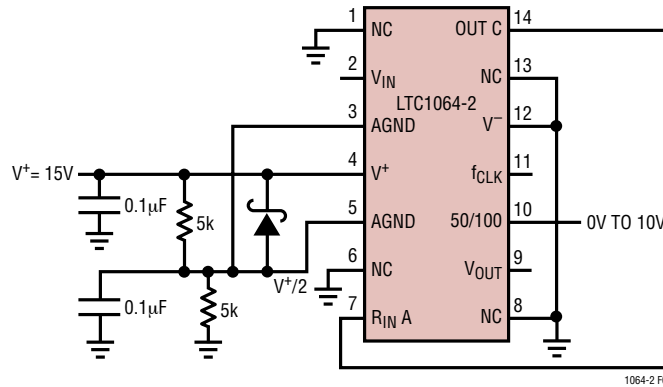

Figure 3. Single Supply Operation. If Fast Power Up or Down Transients are Expected, Use a 1N5817 Schottky Diode Between Pin 4 and Pin 5. For $V^+ = 5V$, Derive the Mid-Supply Voltage with a 7.5k Resistor and an LT1004 2.5V Reference.

TYPICAL APPLICATIONS

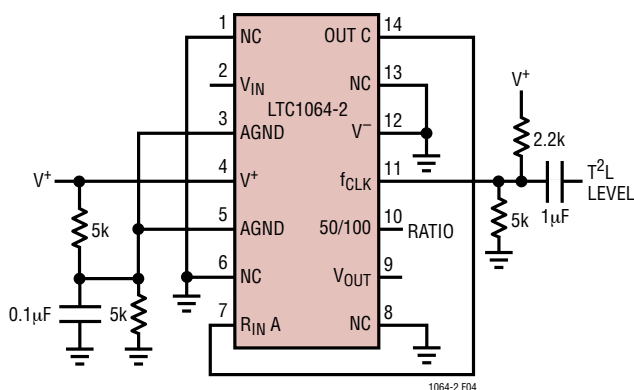

Figure 4. Level Shifting the Input T²L Clock for Single Supply Operation ≥ 6V.

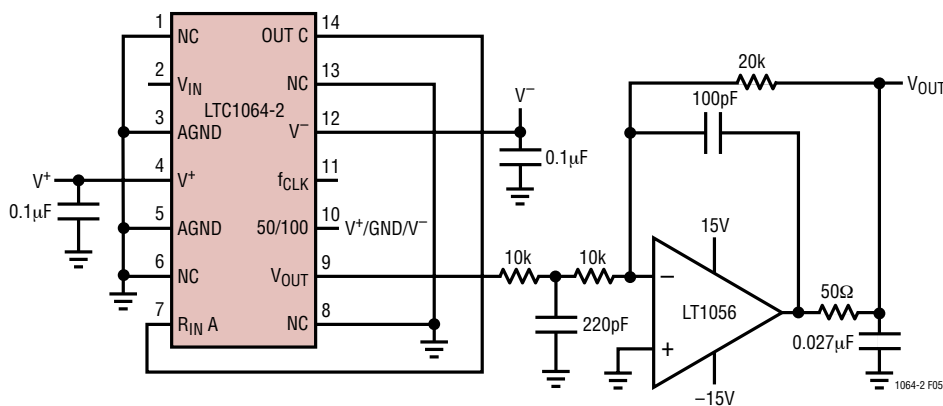
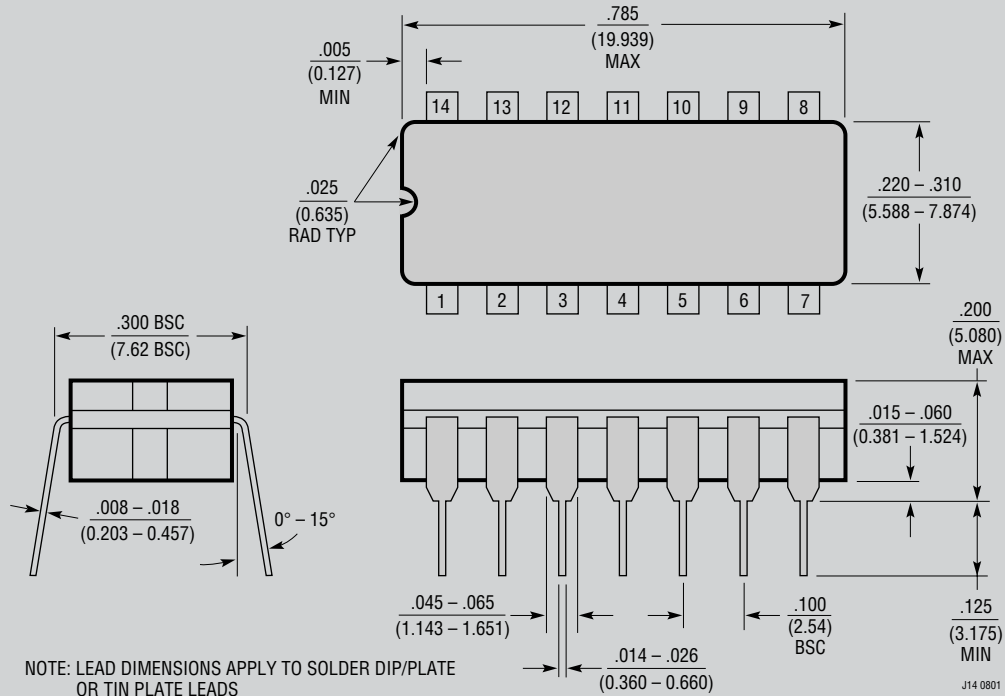

Figure 5. Adding an Output Buffer-Filter to Eliminate Any Clock Feedthrough. Passband ±0.1dB to 50kHz, -3dB at 94kHz.

PACKAGE DESCRIPTION

J Package
14-Lead CERDIP (Narrow 0.300, Hermetic)
 (LTC DWG # 05-08-1110)



PACKAGE DESCRIPTION

N Package 14-Lead PDIP (Narrow 0.300) (LTC DWG # 05-08-1510)

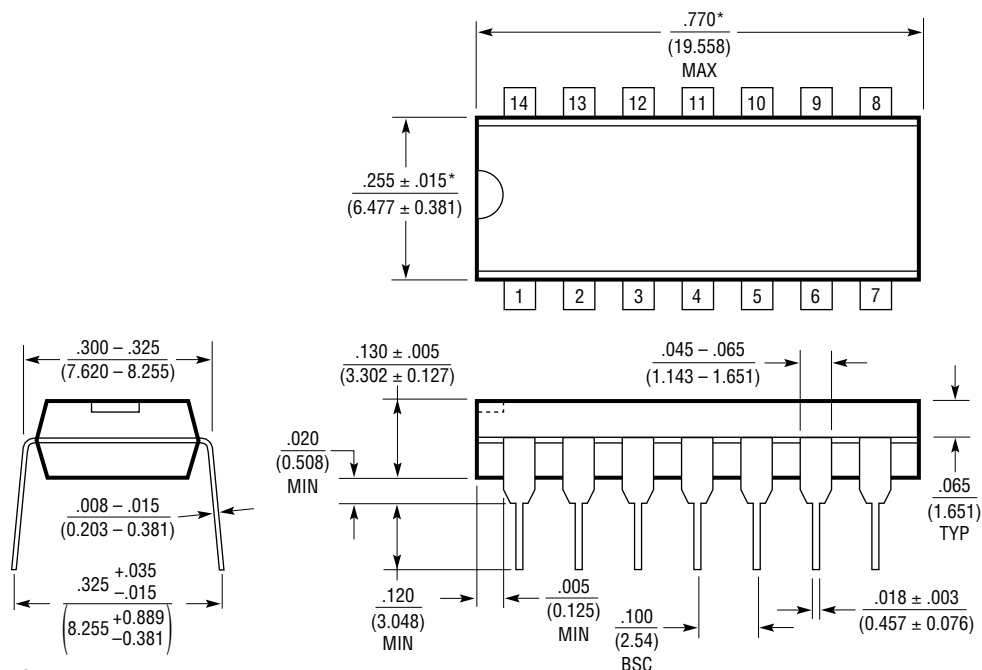

NOTE:
1. DIMENSIONS ARE $\frac{\text{INCHES}}{\text{MILLIMETERS}}$

*THESE DIMENSIONS DO NOT INCLUDE MOLD FLASH OR PROTRUSIONS.
MOLD FLASH OR PROTRUSIONS SHALL NOT EXCEED .010 INCH (0.254mm)

N14 1002

PACKAGE DESCRIPTION

SW Package
16-Lead Plastic Small Outline (Wide .300 Inch)
 (Reference LTC DWG # 05-08-1620)

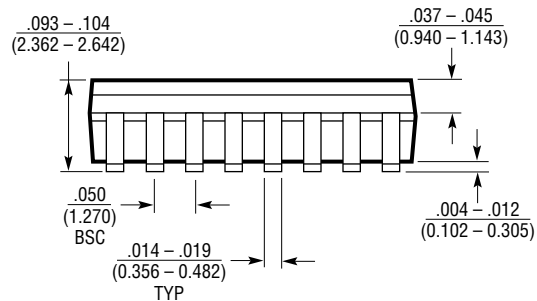
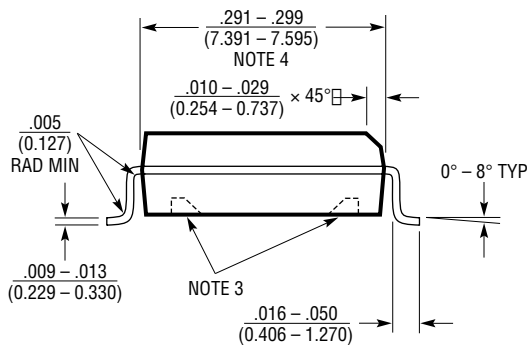
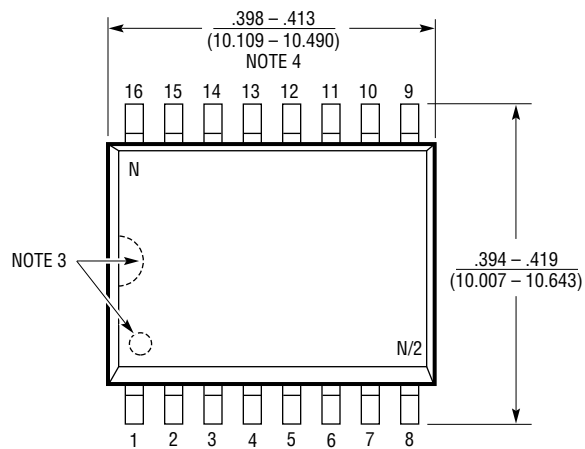
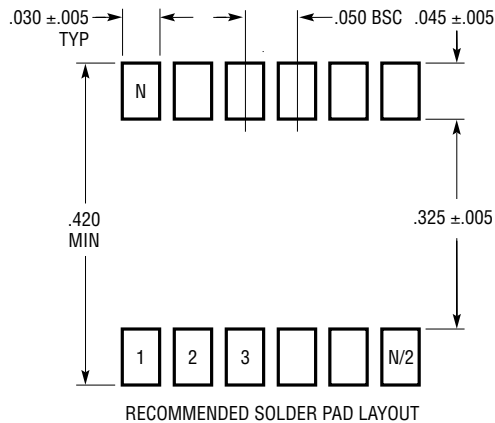

- NOTE:
1. DIMENSIONS IN $\frac{\text{INCHES}}{\text{MILLIMETERS}}$
 2. DRAWING NOT TO SCALE
 3. PIN 1 IDENT, NOTCH ON TOP AND CAVITIES ON THE BOTTOM OF PACKAGES ARE THE MANUFACTURING OPTIONS. THE PART MAY BE SUPPLIED WITH OR WITHOUT ANY OF THE OPTIONS
 4. THESE DIMENSIONS DO NOT INCLUDE MOLD FLASH OR PROTRUSIONS. MOLD FLASH OR PROTRUSIONS SHALL NOT EXCEED .006" (0.15mm)

S16 (WIDE) 0502

Looking for pricing, stock, or lifecycle information?

Click below to explore more details on WIN SOURCE:

⊖ [View LTC1064-2CSW#TRPBF](#) on WIN SOURCE

⊖ [Linear Technology](#) Information

Optimize Your Supply Chain with WIN SOURCE Solutions

- ✓ Global Sourcing Solution
- ✓ Obsolete Management
- ✓ Cost Control Management
- ✓ Shortage Management
- ✓ Alternative Solution
- ✓ Excess Inventory Management