



**THE DATASHEET OF  
LTC1550LCS8-4.1#PBF**



# Low Noise, Switched Capacitor Regulated Voltage Inverters

## FEATURES

- Regulated Negative Voltage from a Single Positive Supply
- Low Output Ripple: Less Than  $1\text{mV}_{\text{P-P}}$  Typ
- High Charge Pump Frequency: 900kHz
- Small Charge Pump Capacitors:  $0.1\mu\text{F}$
- Requires Only Four External Capacitors
- Fixed  $-4.1\text{V}$ ,  $-2.5\text{V}$ ,  $-2\text{V}$  or Adjustable Output
- Shutdown Mode Drops Supply Current to  $<1\mu\text{A}$
- High Output Current: Up to 20mA (Depending on  $V_{\text{CC}}$  to  $V_{\text{OUT}}$  Range)
- Output Regulation: 2.5% Over Line, Load and Temperature
- Available in 8-Lead MSOP, 8-Lead Narrow SO and 16-Lead Narrow SSOP

## APPLICATIONS

- GaAs FET Bias Generators
- Negative Supply Generators
- Battery-Powered Systems
- Single Supply Applications

## DESCRIPTION

The LTC<sup>®</sup>1550L/LTC1551L are switched capacitor charge pump voltage inverters which include internal linear post-regulators to minimize output ripple. The LTC1550L fixed output voltage versions include  $-4.1\text{V}$ ,  $-2.5\text{V}$  and  $-2\text{V}$  with ripple voltages typically below  $1\text{mV}_{\text{P-P}}$ . The LTC1550L is also available in an adjustable output voltage version. The LTC1550L/LTC1551L are ideal for use as bias voltage generators for GaAs transmitter FETs in portable RF and cellular telephone applications.

The LTC1550L/LTC1551L operate from single 2.7V to 5.5V supplies and draw typical quiescent currents of 3.5mA with a 5V supply. Each device includes a TTL compatible Shutdown pin which drops supply current to  $0.2\mu\text{A}$  typically. The LTC1550L Shutdown pin is active low (SHDN), while the LTC1551L Shutdown pin is active high (SHDN). Only four external components are required: an input bypass capacitor, two  $0.1\mu\text{F}$  charge pump capacitors and a filter capacitor at the linear regulator output. The adjustable LTC1550L/LTC1551L require two additional resistors to set the output voltage. The LTC1550L/LTC1551L will supply up to 20mA (depending on  $V_{\text{CC}}$  to  $V_{\text{OUT}}$  range), while maintaining guaranteed output regulation of  $\pm 2.5\%$ .

Both fixed voltage and adjustable LTC1550L/LTC1551L are available in 8-lead MSOP and SO plastic packages: the adjustable LTC1550L is also available in a 16-pin SSOP with the REG pin.

 LTC and LT are registered trademarks of Linear Technology Corporation.

## TYPICAL APPLICATION

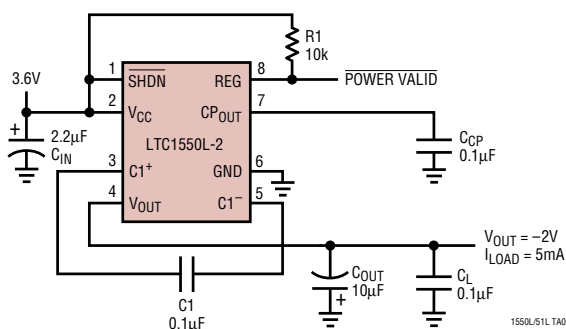
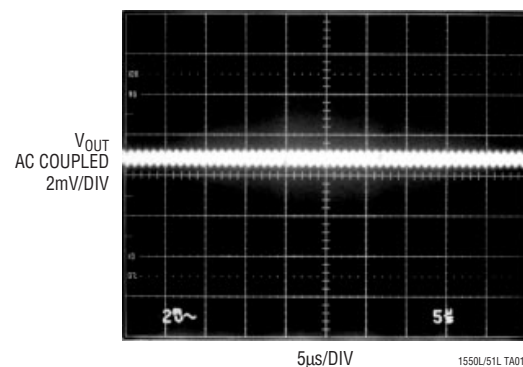

Figure 1.  $-2\text{V}$  Generator with  $1\text{mV}_{\text{P-P}}$  Noise

### $V_{\text{OUT}}$ Output Noise and Ripple



# LTC1550L/LTC1551L

## ABSOLUTE MAXIMUM RATINGS (Note 1)

Supply Voltage .....	5.5V	Commercial Temperature Range .....	0°C to 70°C
Output Voltage .....	0.3V to ( $V_{CC} - 10.5V$ )	Extended Commercial Operating	
Total Voltage, $V_{CC}$ to $CP_{OUT}$ .....	10.8V	Temperature Range (Note 3) .....	-40°C to 85°C
Input Voltage (SHDN Pin) .....	-0.3V to ( $V_{CC} + 0.3V$ )	Industrial Temperature Range .....	-40°C to 85°C
Input Voltage (REG Pin) .....	-0.3V to 6V	Storage Temperature Range .....	-65°C to 150°C
Output Short-Circuit Duration .....	30 sec	Lead Temperature (Soldering, 10 sec) .....	300°C

## PACKAGE/ORDER INFORMATION

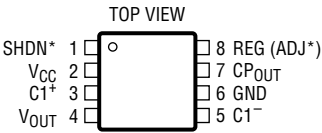
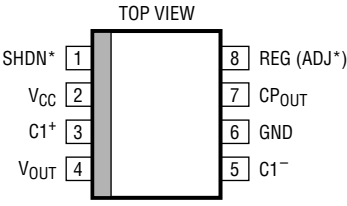
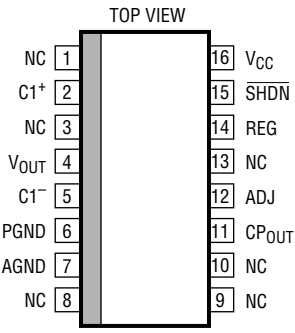
 <p>TOP VIEW</p> <p>SHDN* 1, <math>V_{CC}</math> 2, <math>C1^+</math> 3, <math>V_{OUT}</math> 4, 8 REG (ADJ*), 7 <math>CP_{OUT}</math>, 6 GND, 5 <math>C1^-</math></p> <p>MS8 PACKAGE 8-LEAD PLASTIC MSOP</p> <p>*SHDN FOR LTC1550L, SHDN FOR LTC1551L *FOR ADJUSTABLE VERSION</p> <p><math>T_{JMAX} = 150^{\circ}C, \theta_{JA} = 200^{\circ}C/W</math></p>	 <p>TOP VIEW</p> <p>SHDN* 1, <math>V_{CC}</math> 2, <math>C1^+</math> 3, <math>V_{OUT}</math> 4, 8 REG (ADJ*), 7 <math>CP_{OUT}</math>, 6 GND, 5 <math>C1^-</math></p> <p>S8 PACKAGE 8-LEAD PLASTIC SO</p> <p>*SHDN FOR LTC1550L, SHDN FOR LTC1551L *FOR ADJUSTABLE VERSION</p> <p><math>T_{JMAX} = 150^{\circ}C, \theta_{JA} = 135^{\circ}C/W</math></p>	 <p>TOP VIEW</p> <p>NC 1, <math>V_{CC}</math> 16, <math>C1^+</math> 2, SHDN 15, NC 3, REG 14, <math>V_{OUT}</math> 4, NC 13, <math>C1^-</math> 5, ADJ 12, PGND 6, <math>CP_{OUT}</math> 11, AGND 7, NC 10, NC 8, NC 9</p> <p>GN PACKAGE 16-LEAD PLASTIC SSOP</p> <p><math>T_{JMAX} = 150^{\circ}C, \theta_{JA} = 150^{\circ}C/W</math></p>
ORDER PART NUMBER		ORDER PART NUMBER
LTC1550LCMS8	LTC1551LCMS8	ORDER PART NUMBER
LTC1550LCMS8-2	LTC1551LCMS8-4.1	
LTC1550LCMS8-2.5		
LTC1550LCMS8-4.1		
MS8 PART MARKING		ORDER PART NUMBER
LTEG	LTFQ	LTC1550LCGN
LTGR	LTFT	LTC1550LIGN
LTFV		GN PART MARKING
LTEH		1550L
		1550LI

Consult factory for Military grade parts and additional voltage options.

## ELECTRICAL CHARACTERISTICS

The ● denotes the specifications which apply over the full operating temperature range, otherwise specifications are at  $T_A = 25^{\circ}C$ .  $V_{CC} = 2.7V$  to  $5.25V$ ,  $C1 = C_{CP} = 0.1\mu F$ ,  $C_{OUT} = 10\mu F$ ,  $T_A = 25^{\circ}C$  unless otherwise specified. (Note 3)

SYMBOL	PARAMETER	CONDITIONS	MIN	TYP	MAX	UNITS
$V_{CC}$	Supply Voltage (Adjustable, Fixed -2V) (Fixed -2.5V) (Fixed -4.1V)		● 2.7		5.25	V
			● 3.05		5.25	V
			● 4.5		5.25	V
$V_{REF}$	Reference Voltage	$V_{CC} = 5V, ADJ = GND, V_{REF} = -V_{OUT}$		1.225		V
$\frac{\Delta V_{REF}}{\Delta(V_{CC} - V_{OUT})}$	Reference Voltage Line Regulation	$I_{OUT} = 0mA, 2.7V \leq V_{CC} \leq 5.25V$		2.5		mV/V
$I_S$	Supply Current	$V_{CC} = 5V, V_{SHDN} = V_{CC}$ (LTC1550L) or GND (LTC1551L)	●	3.65	7	mA
		$V_{CC} = 5V, V_{SHDN} = GND$ (LTC1550L) or $V_{CC}$ (LTC1551L)	●	0.2	10	$\mu A$

## ELECTRICAL CHARACTERISTICS

The ● denotes the specifications which apply over the full operating temperature range, otherwise specifications are at  $T_A = 25^\circ\text{C}$ .  $V_{CC} = 2.7\text{V}$  to  $5.25\text{V}$ ,  $C_1 = C_{CP} = 0.1\mu\text{F}$ ,  $C_{OUT} = 10\mu\text{F}$ ,  $T_A = 25^\circ\text{C}$  unless otherwise specified. (Note 3)

SYMBOL	PARAMETER	CONDITIONS	MIN	TYP	MAX	UNITS	
$f_{OSC}$	Internal Oscillator Frequency			900		kHz	
$V_{OL}$	REG Output Low Voltage	$I_{REG} = 1\text{mA}$ , $V_{CC} = 5\text{V}$	●	0.1	0.8	V	
$I_{REG}$	REG Sink Current	$V_{REG} = 0.8\text{V}$ , $V_{CC} = 5\text{V}$	●	4	10	mA	
$V_{IH}$	SHDN Input High Voltage	$V_{CC} = 5\text{V}$	●	2		V	
$V_{IL}$	SHDN Input Low Voltage	$V_{CC} = 5\text{V}$	●		0.8	V	
$I_{IN}$	SHDN Input Current	$V_{SHDN} = V_{CC}$ (All LTC1550L Versions) $V_{SHDN} = V_{CC}$ (All LTC1551L Versions)	●	0.1	1	$\mu\text{A}$	
$t_{ON}$	Turn-On Time	$V_{CC} = 5\text{V}$ , $I_{OUT} = 10\text{mA}$ , $-1.5\text{V} \leq V_{OUT} \leq 4.1\text{V}$ (LTC1550L/LTC1551L)	●	1	5	ms	
		$V_{CC} = 5\text{V}$ , $I_{OUT} = 5\text{mA}$ , $V_{OUT} = -4.5\text{V}$ (LTC1550L/LTC1551L)	●	1	5	ms	
		$V_{CC} = 5\text{V}$ , $I_{OUT} = 10\text{mA}$ , $V_{OUT} = -2\text{V}$ (LTC1550L-2)	●	1	5	ms	
		$V_{CC} = 5\text{V}$ , $I_{OUT} = 10\text{mA}$ , $V_{OUT} = -2.5\text{V}$ (LTC1550L-2.5)	●	1	5	ms	
		$V_{CC} = 5\text{V}$ , $I_{OUT} = 10\text{mA}$ , $V_{OUT} = -4.1\text{V}$ (LTC1550L-4.1/LTC1551L-4.1)	●	1	5	ms	
$V_{OUT}$	Output Regulation (LTC1550L/LTC1551L)	$2.7\text{V} \leq V_{CC} \leq 5.25\text{V}$ , $0 \leq I_{OUT} \leq 5\text{mA}$	●	-1.537	-1.5	-1.463	V
		$2.8\text{V} \leq V_{CC} \leq 5.25\text{V}$ , $0 \leq I_{OUT} \leq 10\text{mA}$	●	-1.537	-1.5	-1.463	V
		$3.5\text{V} \leq V_{CC} \leq 5.25\text{V}$ , $0 \leq I_{OUT} \leq 20\text{mA}$	●	-1.537	-1.5	-1.463	V
$V_{OUT}$	Output Regulation (LTC1550L/LTC1550L-2/ LTC1551L)	$2.7\text{V} \leq V_{CC} \leq 5.25\text{V}$ , $0 \leq I_{OUT} \leq 5\text{mA}$	●	-2.05	-2.0	-1.95	V
		$3.1\text{V} \leq V_{CC} \leq 5.25\text{V}$ , $0 \leq I_{OUT} \leq 10\text{mA}$	●	-2.05	-2.0	-1.95	V
		$3.75\text{V} \leq V_{CC} \leq 5.25\text{V}$ , $0 \leq I_{OUT} \leq 20\text{mA}$	●	-2.05	-2.0	-1.95	V
$V_{OUT}$	Output Regulation (LTC1550L/LTC1550L-2.5/ LTC1551L)	$3.05\text{V} \leq V_{CC} \leq 5.25\text{V}$ , $0 \leq I_{OUT} \leq 5\text{mA}$	●	-2.562	-2.5	-2.438	V
		$3.45\text{V} \leq V_{CC} \leq 5.25\text{V}$ , $0 \leq I_{OUT} \leq 10\text{mA}$	●	-2.562	-2.5	-2.438	V
		$4.1\text{V} \leq V_{CC} \leq 5.25\text{V}$ , $0 \leq I_{OUT} \leq 20\text{mA}$	●	-2.562	-2.5	-2.438	V
$V_{OUT}$	Output Regulation (LTC1550L/LTC1551L)	$3.45\text{V} \leq V_{CC} \leq 5.25\text{V}$ , $0 \leq I_{OUT} \leq 5\text{mA}$	●	-3.075	-3.0	-2.925	V
		$3.85\text{V} \leq V_{CC} \leq 5.25\text{V}$ , $0 \leq I_{OUT} \leq 10\text{mA}$	●	-3.075	-3.0	-2.925	V
		$4.5\text{V} \leq V_{CC} \leq 5.25\text{V}$ , $0 \leq I_{OUT} \leq 20\text{mA}$	●	-3.075	-3.0	-2.925	V
$V_{OUT}$	Output Regulation (LTC1550L/LTC1551L)	$3.9\text{V} \leq V_{CC} \leq 5.25\text{V}$ , $0 \leq I_{OUT} \leq 5\text{mA}$	●	-3.587	-3.5	-3.413	V
		$4.2\text{V} \leq V_{CC} \leq 5.25\text{V}$ , $0 \leq I_{OUT} \leq 10\text{mA}$	●	-3.587	-3.5	-3.413	V
		$4.85\text{V} \leq V_{CC} \leq 5.25\text{V}$ , $0 \leq I_{OUT} \leq 20\text{mA}$	●	-3.587	-3.5	-3.413	V
$V_{OUT}$	Output Regulation (LTC1550L/LTC1550L-4.1) (LTC1551L/LTC1551L-4.1)	$4.5\text{V} \leq V_{CC} \leq 5.25\text{V}$ , $0 \leq I_{OUT} \leq 5\text{mA}$	●	-4.203	-4.1	-3.998	V
		$4.75\text{V} \leq V_{CC} \leq 5.25\text{V}$ , $0 \leq I_{OUT} \leq 10\text{mA}$	●	-4.203	-4.1	-3.998	V
$V_{OUT}$	Output Regulation (LTC1550L/LTC1551L))	$4.8\text{V} \leq V_{CC} \leq 5.25\text{V}$ , $0 \leq I_{OUT} \leq 5\text{mA}$	●	-4.613	-4.5	-4.388	V
		$5.1\text{V} \leq V_{CC} \leq 5.25\text{V}$ , $0 \leq I_{OUT} \leq 10\text{mA}$	●	-4.613	-4.5	-4.388	V
$I_{SC}$	Output Short-Circuit Current	$V_{OUT} = 0\text{V}$ , $V_{CC} = 5.25\text{V}$	●	80	200	mA	
$V_{RIPPLE}$	Output Ripple Voltage			1		mV	

**Note 1:** Absolute Maximum Ratings are those values beyond which the life of a device may be impaired.

**Note 2:** All currents into device pins are positive; all currents out of device pins are negative. All voltages are referenced to ground unless otherwise specified. All typicals are given at  $T_A = 25^\circ\text{C}$ .

**Note 3:** The LTC1550LC/LTC1551LC are guaranteed to meet specified performance from  $0^\circ\text{C}$  to  $70^\circ\text{C}$  and are designed, characterized and expected to meet these extended temperature limits, but are not tested at  $-40^\circ\text{C}$  and  $85^\circ\text{C}$ . The LTC1550LI is guaranteed to meet the extended temperature limits.

# TYPICAL PERFORMANCE CHARACTERISTICS

**Oscillator Frequency vs Temperature**

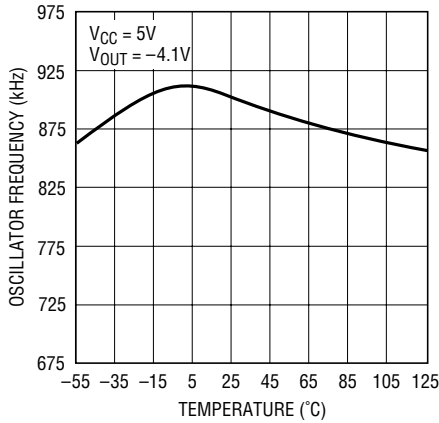

**Supply Current vs Temperature**

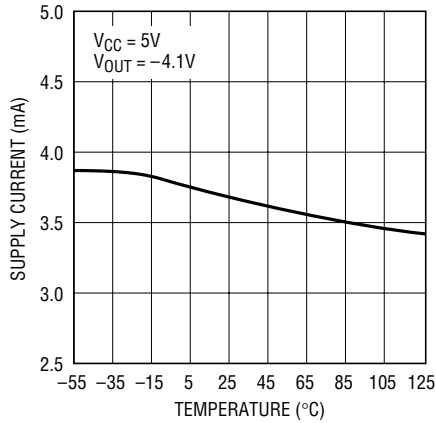

**Minimum Required VCC vs VOUT and IOUT**

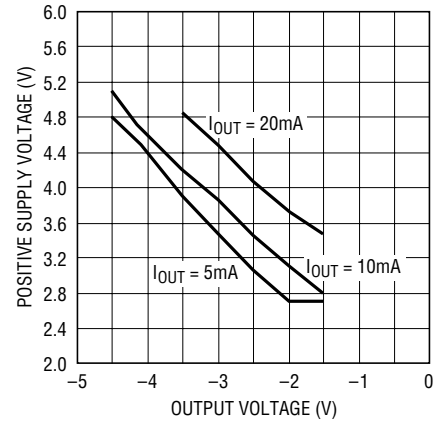

**Maximum Output Current vs Supply Voltage**

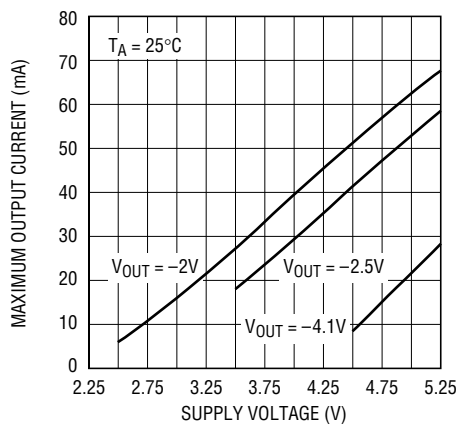

**Start-Up Time vs Supply Voltage**

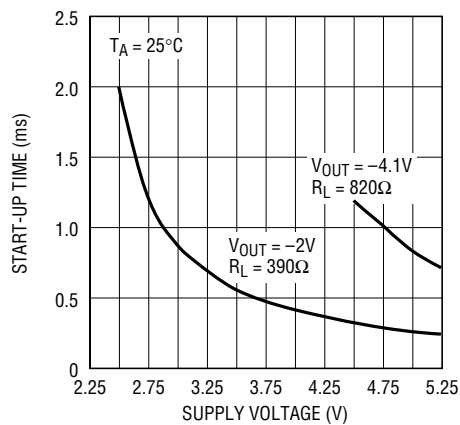

**Reference Voltage vs VCC + |VOUT|**

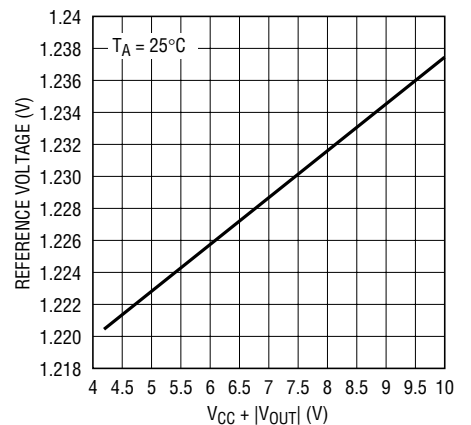

**Startup Time (LTC1550L Shown)**

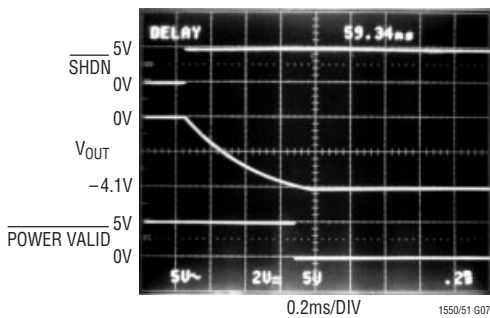

**Load Transient Response (See Figure 3, VCC = 5V)**

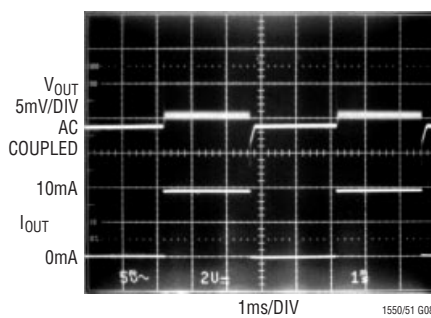

**Line Transient Response (See Figure 3, IL = 10mA)**

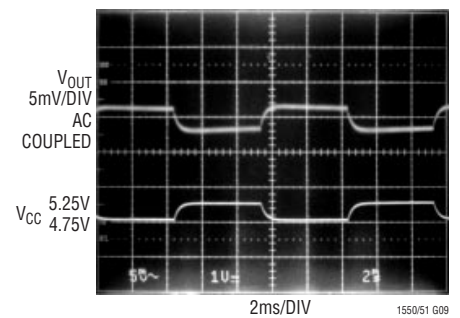

# TYPICAL PERFORMANCE CHARACTERISTICS

Output Spectrum (\*See Figure 1)

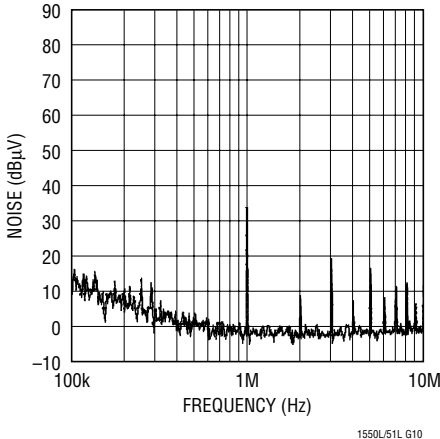

Spot Noise (\*See Figure 1)

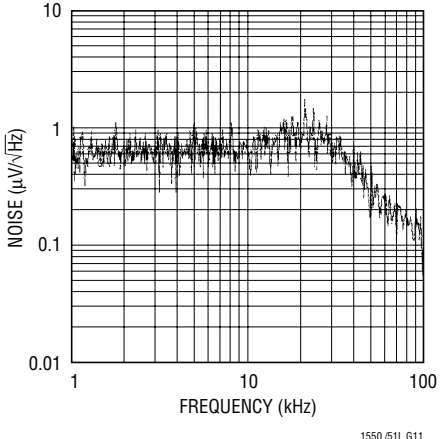

Output Spectrum (See Figure 3)

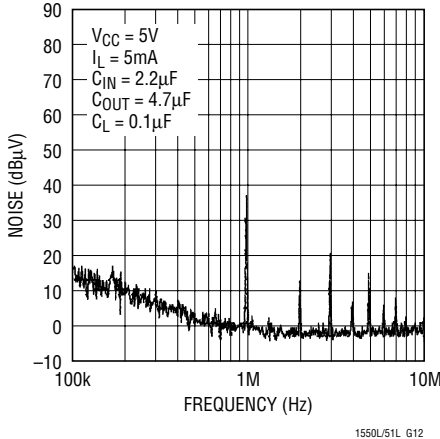

Spot Noise (See Figure 3)

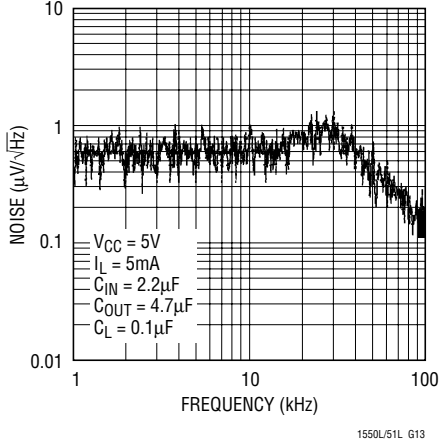

Output Spectrum (See Figure 3)

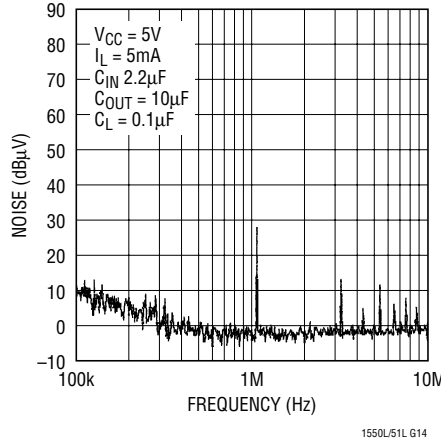

Spot Noise (See Figure 3)

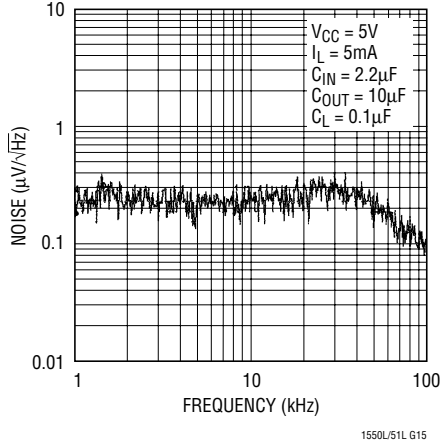

\* On first page of data sheet.

## PIN FUNCTIONS

**SHDN:** Shutdown (TTL Compatible). This pin is active low ( $\overline{\text{SHDN}}$ ) for the LTC1550L and active high (SHDN) for the LTC1551L. When this pin is at  $V_{\text{CC}}$  (GND for LTC1551L), the LTC1550L operates normally. When SHDN is pulled low (SHDN pulled high for LTC1551L), the LTC1550L enters shutdown mode. In shutdown, the charge pump stops, the output collapses to 0V, and the quiescent current drops typically to 0.2 $\mu\text{A}$ . The  $\overline{\text{SHDN}}$  pin for the LTC1550L is a high impedance input and has no internal pull-up. The user must supply a resistor or current source pull-up to default the LTC1550L into normal operation. The SHDN pin for the LTC1551L has an internal 5 $\mu\text{A}$  typical pull-down that defaults the LTC1551L into normal operation.

**$V_{\text{CC}}$ :** Power Supply.  $V_{\text{CC}}$  requires an input voltage between 2.7V and 5.25V. Certain combinations of output voltage and output load current may place additional restrictions on the required input voltage. Consult the Electrical Characteristics table and Typical Performance Characteristics for guaranteed test points. The difference between the input voltage and output should not exceed 10.5V or damage to the chip may occur.  $V_{\text{CC}}$  must be bypassed directly to PGND (GND for 8-pin packages) with at least a 0.1 $\mu\text{F}$  capacitor placed in close proximity to the chip. A 1 $\mu\text{F}$  or larger low ESR bypass capacitor is recommended to minimize noise and ripple at the output. A surface mount ceramic capacitor is recommended.

**$\text{C1}^+$ :** C1 Positive Input. Connect a 0.1 $\mu\text{F}$  capacitor between  $\text{C1}^+$  and  $\text{C1}^-$ .

**$V_{\text{OUT}}$ :** Negative Voltage Output. This pin must be bypassed with a 4.7 $\mu\text{F}$  or larger capacitor to ensure regulator loop stability. LTC recommends at least 10 $\mu\text{F}$  to achieve the specified output ripple. The output capacitor should be a moderate ESR capacitor, and not a very low ESR capacitor, as the zero in the feedback loop (formed by the ESR and the output capacitor) provides phase lead to the linear regulator feedback loop. Using very low ESR output capacitors will result in the output oscillating. A low ESR 0.1 $\mu\text{F}$  capacitor is recommended in parallel with the main output capacitor to minimize high frequency spikes at the output. The ground connection for the output capacitor

should connect directly to the  $V_{\text{CC}}$  and  $\text{CP}_{\text{OUT}}$  bypass capacitors, as well as to the GND of the LTC1550L/LTC1551L. LTC recommends a separate trace for the  $V_{\text{OUT}}$  capacitor ground connection to minimize noise.

**$\text{C1}^-$ :** C1 Negative Input. Connect a 0.1 $\mu\text{F}$  capacitor from  $\text{C1}^+$  to  $\text{C1}^-$ .

**GND:** Ground. Connect to a low impedance ground. A ground plane will help minimize regulation errors.

**$\text{CP}_{\text{OUT}}$ :** Negative Charge Pump Output. This pin requires a 0.1 $\mu\text{F}$  storage capacitor to ground. In order to achieve ripple on the output voltage of less than 1mV, the ground connection for the  $\text{CP}_{\text{OUT}}$  capacitor must tie directly to the bottom of the  $V_{\text{CC}}$  bypass capacitor and at the GND pin of the LTC1550L/LTC1551L. This minimizes the AC current path for the charge pump.

**REG:** This is an open-drain output that pulls low when the output voltage is within 5% of the set value. It will sink 4mA to ground with a 5V supply. The external circuitry must provide a pull-up or REG will not swing high. The voltage at REG may exceed  $V_{\text{CC}}$  and can be pulled up to 6V above ground without damage. For the LTC1550L adjustable voltage version, the REG pin is only available in the 16-lead GN package.

**ADJ (for adjustable versions):** This is the feedback point for the external resistor divider string. Connect a divider string from GND to  $V_{\text{OUT}}$  with the divided tap connected to ADJ. Note that the resistor string needs to be connected “upside-down” from a negative regulator. See the Applications Information section for hook-up details.

### GN PACKAGE ONLY

**PGND:** Power Ground. Connect to a low impedance ground. PGND should be connected to the same potential as AGND.

**AGND:** Analog Ground. Connect to a low impedance ground. AGND should be connected to a ground plane to minimize regulation errors.

**NC:** No Internal Connection.

## BLOCK DIAGRAM

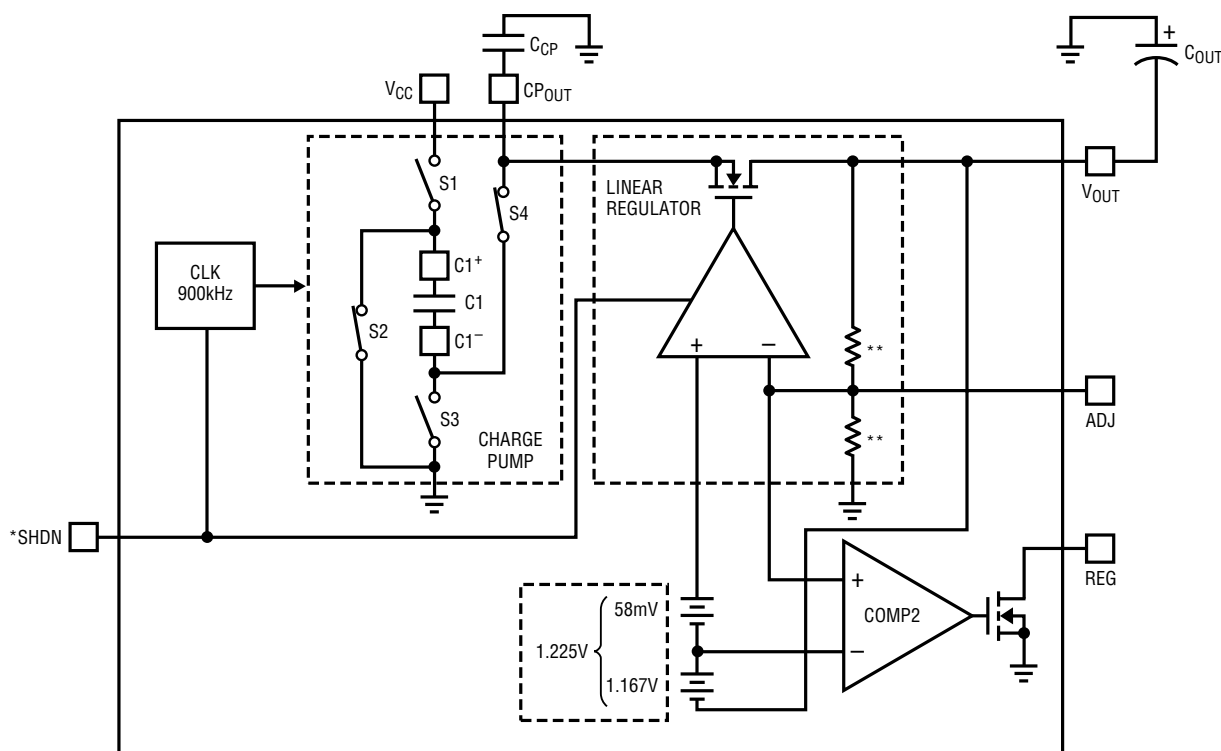

\*SHDN FOR LTC1550L, SHDN FOR LTC1551L  
 \*\* FIXED OUTPUT VERSIONS ONLY

1550L/51L BD

## APPLICATIONS INFORMATION

### OVERVIEW

The LTC1550L/LTC1551L are switched capacitor, inverting charge pumps with internal linear post-regulators. The LTC1550L/LTC1551L provide a regulated, low ripple output at up to 20mA load current with the appropriate input voltage as output load current depends on the input/output voltage combination. Consult the graph provided in the Typical Performance Characteristics section and the Electrical Characteristics table for guaranteed test points. The LTC1550L/LTC1551L are ideal for use as bias voltage

generators for GaAs transmitter FETs in portable RF and cellular telephone applications. The LTC1550L features an active-low Shutdown pin (SHDN) that drops quiescent current to below  $1\mu\text{A}$ . The LTC1551L is identical to the LTC1550L, except that the Shutdown pin is active-high (SHDN). All members of the LTC1550L/LTC1551L family feature a 900kHz charge pump frequency. The LTC1550L/LTC1551L come standard with fixed  $-4.1\text{V}$ ,  $-2.5\text{V}$ ,  $-2\text{V}$  and adjustable output voltages. The LTC1550L/LTC1551L can be configured for other fixed output voltages; contact Linear Technology for more information.

## APPLICATIONS INFORMATION

The LTC1550L/LTC1551L consist of two major blocks (see Block Diagram): an inverting charge pump and a negative linear regulator. The charge pump uses two external capacitors, C1 and C<sub>CP</sub> to generate a negative voltage at CP<sub>OUT</sub>. It operates by charging and discharging C1 on alternate phases of the internal 900kHz clock. C1 is initially charged to V<sub>CC</sub> through switches S1 and S3. When the internal clock changes phase, S1 and S3 open and S2 and S4 close, shorting the positive side of C1 to ground. This forces the negative side of C1 below ground, and charge is transferred to C<sub>CP</sub> through S4. As this cycle repeats, the magnitude of the negative voltage approaches V<sub>CC</sub>. The 900kHz internal clock frequency helps keep noise out of the 400kHz to 600kHz IF bands commonly used by portable radio frequency systems and reduces the size of the external capacitors required. Most applications can use standard 0.1μF ceramic capacitors for C1 and C<sub>CP</sub>. Increasing C1 and C<sub>CP</sub> beyond 0.1μF has little effect on the output ripple or the output current capacity of the LTC1550L/LTC1551L.

The negative voltage at CP<sub>OUT</sub> supplies the input to the negative regulator block. This block consists of an N-channel MOSFET pass device and a feedback amplifier that monitors the output voltage and compares it to the internal reference. The regulated output appears at the V<sub>OUT</sub> pin. The regulation loop is optimized for fast transient response, enabling it to remove most of the switching artifacts present at the CP<sub>OUT</sub> pin. Output ripple is typically below 1mV<sub>P-P</sub> with output loads between 0mA and 10mA. The output voltage is set by a pair of internal divider resistors for the fixed voltage versions. The N-channel pass device minimizes dropout, allowing the output to remain in regulation with supply voltages as low as 2.7V for an output voltage of -2V. An output capacitor of at least 4.7μF from V<sub>OUT</sub> to ground is required to keep the regulator loop stable; for optimum stability and minimum output ripple, at least 10μF is recommended.

### Adjustable Hook-Up

For the adjustable LTC1550L/LTC1551L, the output voltage is set with a resistor divider from GND to V<sub>OUT</sub> (Figure 2). Note that the internal reference and the internal feedback amplifier are set up as a positive-output regulator referenced to the V<sub>OUT</sub> pin, not as a negative regulator

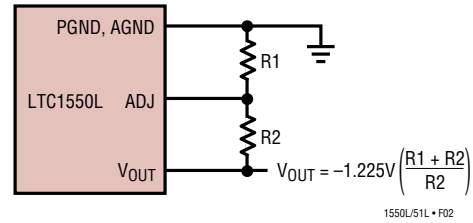

Figure 2. External Resistor Connections

referenced to ground. The output resistor divider must be set to provide 1.225V at the ADJ pin with respect to V<sub>OUT</sub>. For example, a -3V output would require a 17.4k resistor from GND to ADJ, and a 12.1k resistor to V<sub>OUT</sub>.

### CAPACITOR SELECTION

The LTC1550L/LTC1551L requires four external capacitors: an input bypass capacitor, two 0.1μF charge pump capacitors and an output filter capacitor. The overall behavior of the LTC1550L/LTC1551L is strongly affected by how the capacitors are used, and by how the capacitors are laid out on the printed circuit board (PCB). In particular, the output capacitor's value and ESR have a significant effect on the output ripple and noise performance. In addition, the ground connections for the V<sub>CC</sub> bypass capacitor, the CP<sub>OUT</sub> capacitor and the V<sub>OUT</sub> bypass capacitor must employ star-ground techniques at the GND pin of the LTC1550L/LTC1551L. Proper capacitor selection is critical for optimum performance of the LTC1550L/LTC1551L.

### Output Ripple vs Output Capacitor

Figure 4 shows the effect of using different output capacitor values on the LTC1550L/LTC1551L output ripple. These curves are taken using the LTC1551L circuit in Figure 3, with C<sub>IN</sub> = 2.2μF and I<sub>LOAD</sub> = 5mA. The upper curve shows the performance with a standard tantalum capacitor alone and the lower curve shows that of the tantalum capacitor in parallel with a 0.1μF ceramic capacitor. As a general rule, larger output capacitors provide lower output ripple. To keep output voltage ripple below 1mV<sub>P-P</sub>, 10μF, or greater, in parallel with a 0.1μF ceramic capacitor is required. To guarantee loop stability under all conditions, a minimum of 4.7μF is required at the output.

## APPLICATIONS INFORMATION

Figure 4 shows a marked decrease in peak-to-peak output ripple when a 0.1μF ceramic capacitor is added in parallel with the tantalum output capacitor. The additional ripple with the tantalum output capacitor alone is mostly very high order harmonics of the 900kHz clock, which appear as sharp "spikes" at the output. The energy in these spikes is very small and they do not contribute to the RMS output voltage, but their peak-to-peak amplitude can be several millivolts under some conditions. A 0.1μF ceramic capacitor has significantly lower impedance at the spike frequency than a large tantalum capacitor, and eliminates most of these left-over switching spikes that the tantalum capacitor leaves behind. Figure 5 and 6 show scope photos of the output of Figure 4 with and without the additional ceramic capacitor at the output.

A series RC or LC filter can reduce high frequency output noise even further. Due to the high 900kHz switching frequency, not much R or L is required; a ferrite bead or a relatively long PC board trace in series with 0.1μF ceramic capacitor will usually keep the output ripple well below 1mV<sub>P-P</sub>. Figure 1 shows an example of an ultralow noise -2V generator. The corresponding spectrum and spot noise plots for this circuit are shown in the Typical Performance Characteristics section.

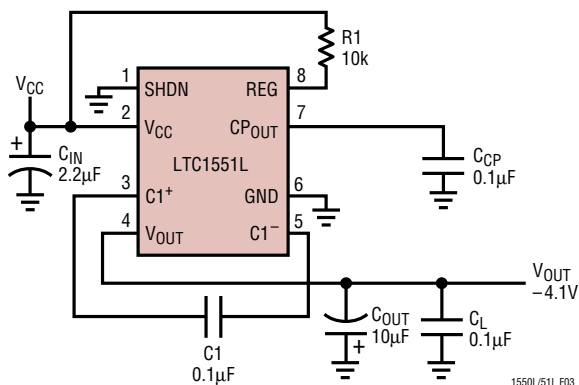

Figure 3. Output Ripple Test Circuit

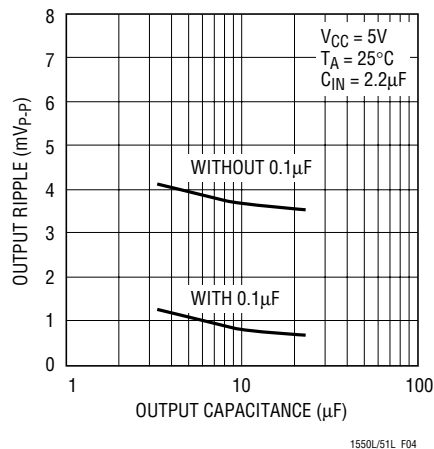

Figure 4. Output Ripple vs Output Capacitance

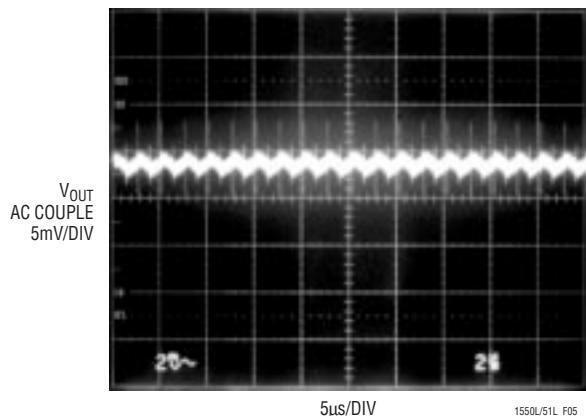

Figure 5. Output Ripple with 10μF Tantalum Capacitor

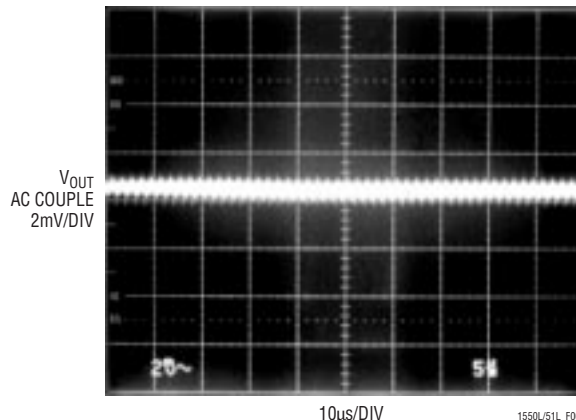

Figure 6. Output Ripple with 10μF Tantalum Capacitor Paralleled with 0.1μF Ceramic Capacitor

## APPLICATIONS INFORMATION

### Output Ripple vs Input Bypass Capacitor

The input bypass capacitor ( $C_{IN}$ ) can also have a fairly significant impact on the output ripple.  $C_{IN}$  provides most of the LTC1550L/LTC1551L's supply current while it is charging the flying capacitor ( $C1$ ). Inadequate input bypassing can cause the  $V_{CC}$  supply to dip when the charge pump switches, causing the output linear regulator to momentarily stop regulating.  $C_{IN}$  should be mounted as close to the LTC1550L/LTC1551L  $V_{CC}$  and GND pins as possible and its value should be significantly larger than

$C1$ . Surface mount tantalum or ceramic capacitors with low ESR generally provide adequate performance. Figure 7 shows the LTC1550L/LTC1551L peak-to-peak output ripple vs  $C_{IN}$ , taken using the test circuit in Figure 3 with  $I_{LOAD}$  set at 5mA.  $C_{OUT}$  is a  $10\mu\text{F}$  in parallel with a  $0.1\mu\text{F}$  ceramic capacitor.

A  $2.2\mu\text{F}$  surface mount ceramic capacitor at  $V_{CC}$  generally provides adequate output ripple performance for most applications.

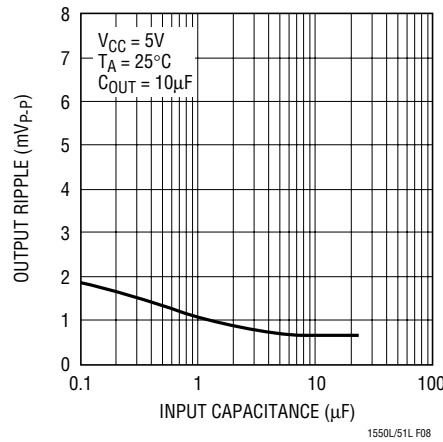
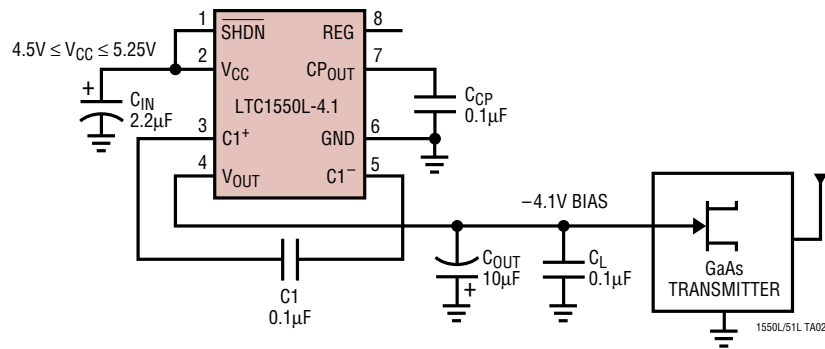

Figure 7. Output Ripple vs Input Bypass Capacitance

## TYPICAL APPLICATION

### -4.1V Output GaAs FET Bias Generator



**PACKAGE DESCRIPTION**

Dimensions in inches (millimeters) unless otherwise noted.

**GN Package**  
**16-Lead Plastic SSOP (Narrow 0.150)**  
 (LTC DWG # 05-08-1641)

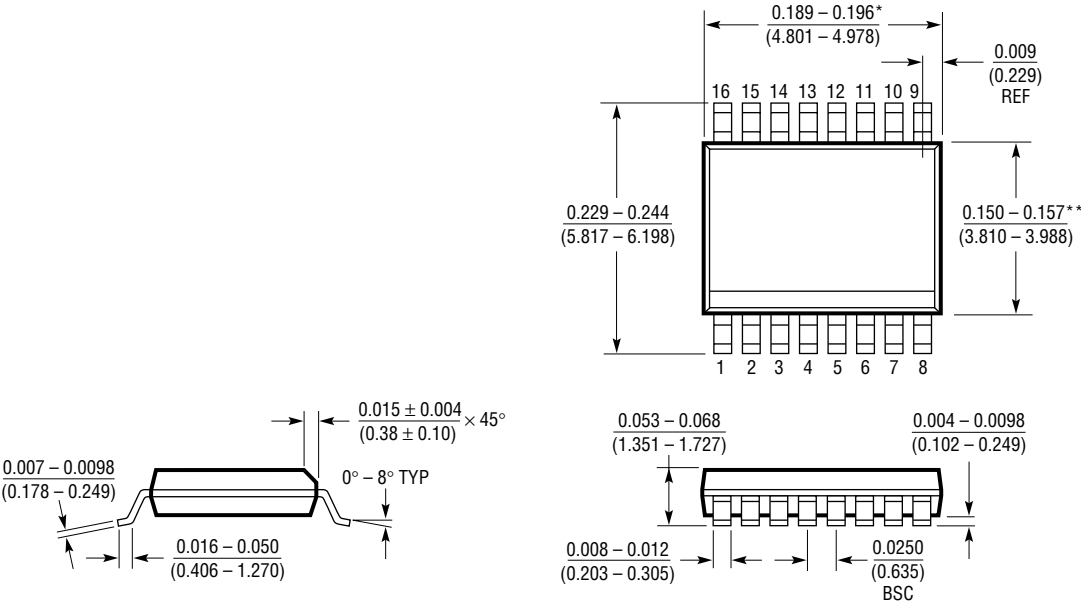

\* DIMENSION DOES NOT INCLUDE MOLD FLASH. MOLD FLASH SHALL NOT EXCEED 0.006\* (0.152mm) PER SIDE  
 \*\* DIMENSION DOES NOT INCLUDE INTERLEAD FLASH. INTERLEAD FLASH SHALL NOT EXCEED 0.010\* (0.254mm) PER SIDE

GN16 (SSOP) 1098

**MS8 Package**  
**8-Lead Plastic MSOP**  
 (LTC DWG # 05-08-1660)

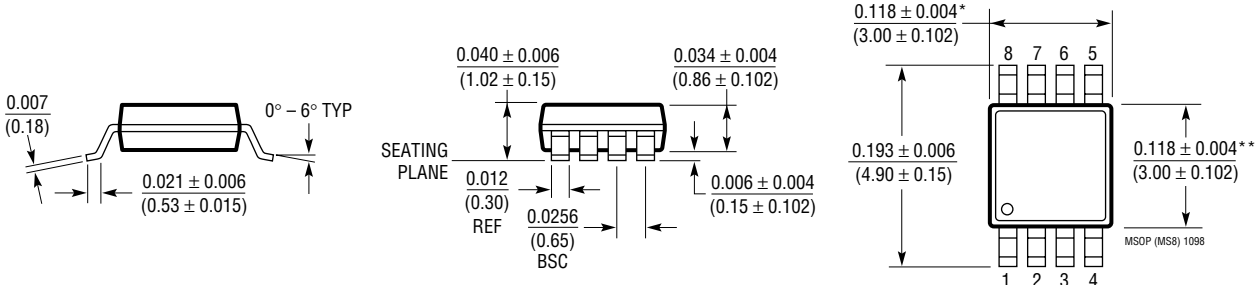

\* DIMENSION DOES NOT INCLUDE MOLD FLASH, PROTRUSIONS OR GATE BURRS. MOLD FLASH, PROTRUSIONS OR GATE BURRS SHALL NOT EXCEED 0.006\* (0.152mm) PER SIDE  
 \*\* DIMENSION DOES NOT INCLUDE INTERLEAD FLASH OR PROTRUSIONS. INTERLEAD FLASH OR PROTRUSIONS SHALL NOT EXCEED 0.006\* (0.152mm) PER SIDE

MSOP (MS8) 1098

## TYPICAL APPLICATION

1mV<sub>p-p</sub> Ripple, -2V Output GaAs FET Bias Generator

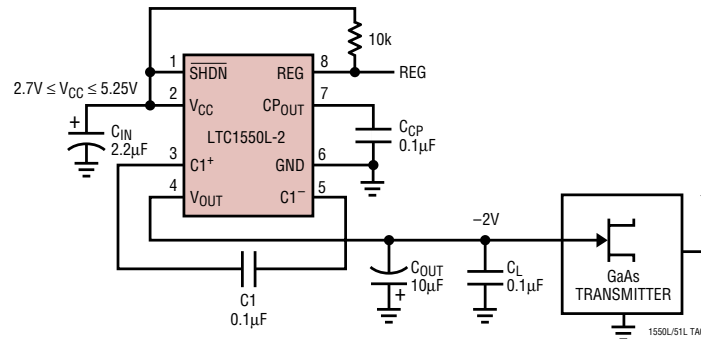

## PACKAGE DESCRIPTION

Dimensions in inches (millimeters) unless otherwise noted.

**S8 Package**  
**8-Lead Plastic Small Outline (Narrow 0.150)**  
 (LTC DWG # 05-08-1610)

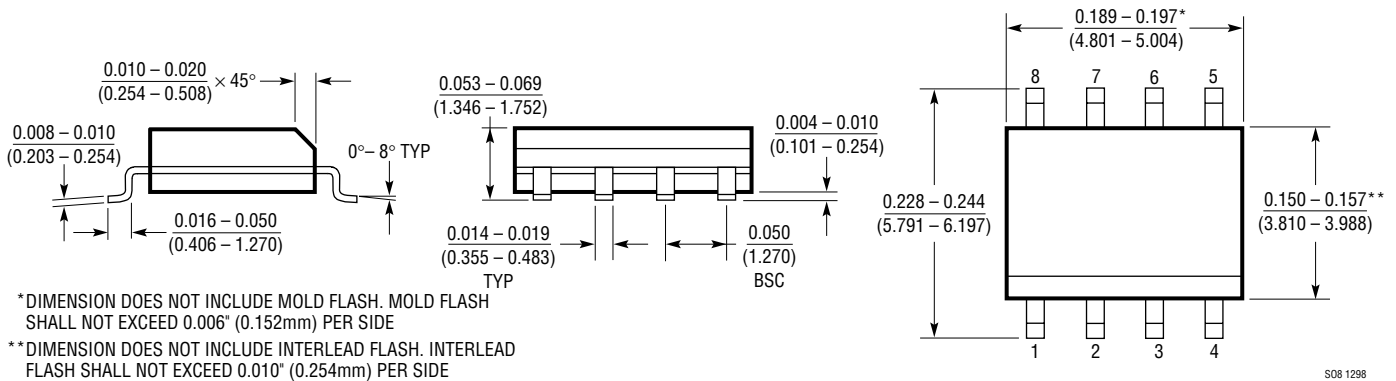

## RELATED PARTS

PART NUMBER	DESCRIPTION	COMMENTS
LT <sup>®</sup> 1054	Switched-Capacitor Voltage Converter with Regulator	100mA Switched-Capacitor Converter
LTC1261	Switched-Capacitor Regulated Voltage Inverter	Selectable Fixed Output Voltages
LTC1261L	Switched-Capacitor Regulated Voltage Inverter	Adjustable and Fixed Output Voltages, Up to 20mA I <sub>OUT</sub> , MSOP
LTC1429	Clock-Synchronized Switched-Capacitor Voltage Inverter	Synchronizable Up to 2MHz System Clock
LTC1514/LTC1515	Step-Up/Step-Down Switched-Capacitor DC/DC Converters	V <sub>IN</sub> 2V to 10V, Adjustable or Fixed V <sub>OUT</sub> , I <sub>OUT</sub> to 50mA
LTC1516	Micropower Regulated 5V Charge Pump DC/DC Converter	I <sub>OUT</sub> = 20mA (V <sub>IN</sub> ≥ 2V), I <sub>OUT</sub> = 50mA (V <sub>IN</sub> ≥ 3V)
LTC1522	Micropower Regulated 5V Charge Pump DC/DC Converter	I <sub>OUT</sub> = 10mA (V <sub>IN</sub> ≥ 2.7V), I <sub>OUT</sub> = 20mA (V <sub>IN</sub> ≥ 3V)
LTC1550/LTC1551	Low Noise, Switched-Capacitor Regulated Voltage Inverters	900kHz Charge Pump, 1mV <sub>p-p</sub> Ripple
LTC1555/LTC1556	SIM Power Supply and Level Translator	Step-Up/Step-Down SIM Power Supply and Level Translators
LT1611	1.4MHz Inverting Mode Switching Regulator	-5V at 150mA from a 5V Input, 5-Lead SOT-23
LT1614	Inverting 600kHz Switching Regulator with Low-Battery Detector	-5V at 200mA from a 5V Input, MSOP
LTC1754-5	Micropower, Regulated 5V Charge Pump with Shutdown in SOT-23	I <sub>CC</sub> = 13µA, I <sub>OUT</sub> = 50mA (V <sub>IN</sub> ≥ 3V), I <sub>OUT</sub> = 25mA (V <sub>IN</sub> ≥ 2.7V)

## Looking for pricing, stock, or lifecycle information?

Click below to explore more details on WIN SOURCE:

 [View LTC1550LCS8-4.1#PBF on WIN SOURCE](#)

 [Linear Technology](#) Information

## Optimize Your Supply Chain with WIN SOURCE Solutions

-  Global Sourcing Solution
-  Obsolete Management
-  Cost Control Management
-  Shortage Management
-  Alternative Solution
-  Excess Inventory Management