



**THE DATASHEET OF
LTC1606CSW#PBF**



FEATURES

- **Sample Rate: 250ksps**
- **Single 5V Supply**
- **Bipolar Input Range: $\pm 10V$**
- **Signal-to-Noise Ratio: 90dB Typ**
- **Power Dissipation: 75mW Typ**
- **Guaranteed No Missing Codes**
- Integral Nonlinearity: $\pm 2.0\text{LSB}$ Max
- Operates with Internal or External Reference
- Internal Synchronized Clock
- 28-Pin SSOP and SO Packages
- 100ksps Version (LTC1605)
- Improved 2nd Source to AD976A and ADS7805
- Available in 28-Lead Plastic SSOP and SO Packages

APPLICATIONS

- Industrial Process Control
- Multiplexed Data Acquisition Systems
- High Speed Data Acquisition for PCs
- Digital Signal Processing

DESCRIPTION

The LTC[®]1606 is a 250ksps, sampling 16-bit A/D converter that draws only 75mW (typical) from a single 5V supply. This easy-to-use device includes sample-and-hold, precision reference, switched capacitor successive approximation A/D and trimmed internal clock.

The LTC1606's input range is an industry standard $\pm 10V$. Maximum DC specs include $\pm 2.0\text{LSB}$ INL and 16 bits no missing codes over temperature. An external reference can be used if greater accuracy over temperature is needed.

The 90dB signal-to-noise ratio offers an improvement of 3dB over competing devices, and the RMS transition noise is reduced (0.65LSB vs 1LSB) relative to competitive parts.

The ADC has a microprocessor compatible, 16-bit or two byte parallel output port. A convert start input and a data ready signal (BUSY) ease connections to FIFOs, DSPs and microprocessors.

LT, LTC and LT are registered trademarks of Linear Technology Corporation. All other trademarks are the property of their respective owners.

BASIC CONFIGURATION

Low Power, 250kHz, 16-Bit Sampling ADC on 5V Supply

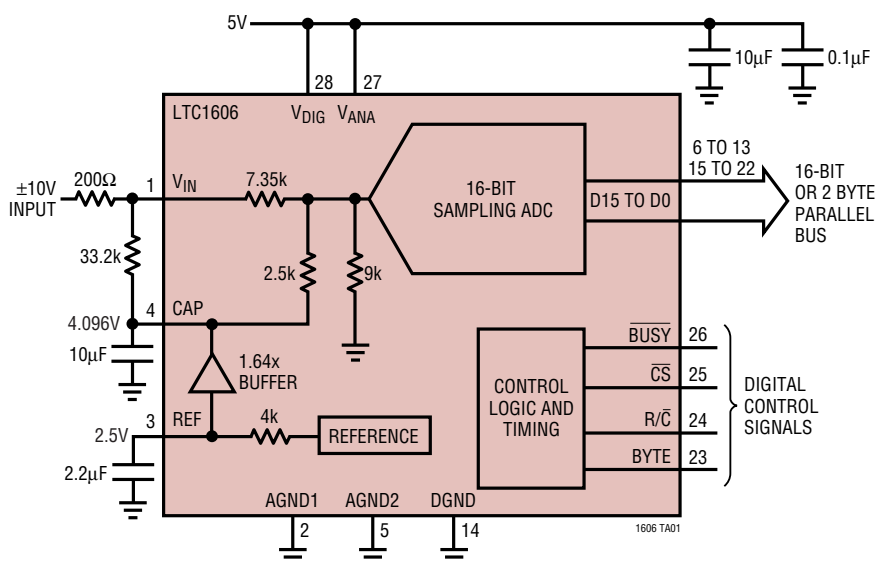

Typical INL Curve

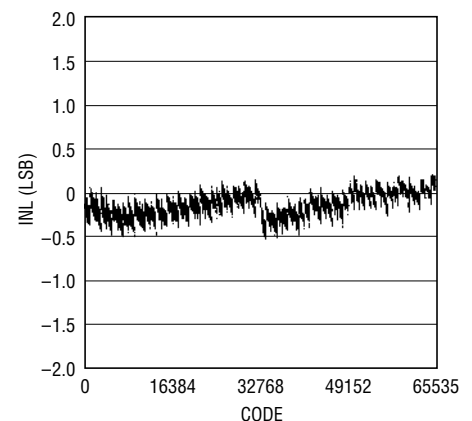

1606 G04

1606fa

ABSOLUTE MAXIMUM RATINGS

(Notes 1, 2)

V_{ANA}	7V
V_{DIG} to V_{ANA}	0.3V
V_{DIG}	7V
Ground Voltage Difference DGND, AGND1 and AGND2	$\pm 0.3V$
Analog Inputs (Note 3)	
V_{IN}	$\pm 25V$
CAP	$V_{ANA} + 0.3V$ to $AGND2 - 0.3V$
REF	Indefinite Short to AGND2 Momentary Short to V_{ANA}
Digital Input Voltage (Note 4)	$V_{DGND} - 0.3V$ to 10V
Digital Output Voltage	$V_{DGND} - 0.3V$ to $V_{DIG} + 0.3V$
Power Dissipation	500mW
Operating Ambient Temperature Range	
LTC1606AC/LTC1606C	0°C to 70°C
LTC1606AI/LTC1606I	-40°C to 85°C
Storage Temperature Range	-65°C to 150°C
Lead Temperature (Soldering, 10 sec)	300°C

PACKAGE/ORDER INFORMATION

TOP VIEW		ORDER PART NUMBER
V_{IN} [1]	[28] V_{DIG}	LTC1606ACG
AGND1 [2]	[27] V_{ANA}	LTC1606AIG
REF [3]	[26] \overline{BUSY}	LTC1606CG
CAP [4]	[25] \overline{CS}	LTC1606IG
AGND2 [5]	[24] R/\overline{C}	LTC1606ACSW
D15 (MSB) [6]	[23] BYTE	LTC1606AISW
D14 [7]	[22] D0	LTC1606CSW
D13 [8]	[21] D1	LTC1606ISW
D12 [9]	[20] D2	
D11 [10]	[19] D3	
D10 [11]	[18] D4	
D9 [12]	[17] D5	
D8 [13]	[16] D6	
DGND [14]	[15] D7	
G PACKAGE SW PACKAGE 28-LEAD PLASTIC SSOP 28-LEAD PLASTIC SO		
$T_{JMAX} = 125^{\circ}C, \theta_{JA} = 95^{\circ}C/W$ (G) $T_{JMAX} = 125^{\circ}C, \theta_{JA} = 130^{\circ}C/W$ (SW)		
Order Options Tape and Reel: Add #TR Lead Free: Add #PBF Lead Free Tape and Reel: Add #TRPBF Lead Free Part Marking: http://www.linear.com/leadfree/		

Consult LTC Marketing for parts specified with wider operating temperature ranges.

CONVERTER CHARACTERISTICS

The ● indicates specifications which apply over the full operating temperature range, otherwise specifications are at $T_A = 25^{\circ}C$. (Notes 5, 6)

PARAMETER	CONDITIONS	LTC1606			LTC1606A			UNITS
		MIN	TYP	MAX	MIN	TYP	MAX	
Resolution		●	16		16			Bits
No Missing Codes		●	15		16			Bits
Transition Noise				0.65		0.65		LSB _{RMS}
Integral Linearity Error	(Note 7)	●		± 3		± 2		LSB
Bipolar Zero Error	Ext. Reference = 2.5V (Note 8)	●		± 10		± 10		mV
Bipolar Zero Error Drift				± 2		± 2		ppm/°C
Full-Scale Error Drift				± 7		± 5		ppm/°C
Full-Scale Error	Ext. Reference = 2.5V (Notes 12, 13)	●		± 0.50		± 0.25		%
Full-Scale Error Drift	Ext. Reference = 2.5V			± 2		± 2		ppm/°C
Power Supply Sensitivity $V_{ANA} = V_{DIG} = V_{DD}$	$V_{DD} = 5V \pm 5\%$ (Note 9)			± 8		± 8		LSB

ANALOG INPUT

The ● indicates specifications which apply over the full operating temperature range, otherwise specifications are at $T_A = 25^\circ\text{C}$. (Note 5)

SYMBOL	PARAMETER	CONDITIONS	LTC1606/LTC1606A			UNITS
			MIN	TYP	MAX	
V_{IN}	Analog Input Range (Note 9)	$4.75\text{V} \leq V_{ANA} \leq 5.25\text{V}$, $4.75\text{V} \leq V_{DIG} \leq 5.25\text{V}$		±10		V
C_{IN}	Analog Input Capacitance			10		pF
R_{IN}	Analog Input Impedance			10		k Ω

DYNAMIC ACCURACY

(Notes 5, 14)

SYMBOL	PARAMETER	CONDITIONS	LTC1606			LTC1606A			UNITS
			MIN	TYP	MAX	MIN	TYP	MAX	
S/(N + D)	Signal-to-(Noise + Distortion) Ratio	1kHz Input Signal (Note 14)		90			90		dB
		10kHz Input Signal	83	90		87	90		dB
		20kHz, -60dB Input Signal		30			30		dB
THD	Total Harmonic Distortion	1kHz Input Signal, First 5 Harmonics		-102			-102		dB
		10kHz Input Signal, First 5 Harmonics	-87	-94		-89	-94		dB
	Peak Harmonic or Spurious Noise	1kHz Input Signal		-102			-102		dB
		10kHz Input Signal		-94			-94		dB
	Full-Power Bandwidth	(Note 15)		275			275		kHz
	Aperture Delay			40			40		ns
	Aperture Jitter		Sufficient to Meet AC Specs			Sufficient to Meet AC Specs			
	Transient Response	Full-Scale Step (Note 9)			1			1	μs
	Overvoltage Recovery	(Note 16)		150			150		ns

INTERNAL REFERENCE CHARACTERISTICS

The ● indicates specifications which apply over the full operating temperature range, otherwise specifications are at $T_A = 25^\circ\text{C}$. (Note 5)

PARAMETER	CONDITIONS	LTC1606/LTC1606A			UNITS	
		MIN	TYP	MAX		
V_{REF} Output Voltage	$I_{OUT} = 0$		2.470	2.500	2.520	V
V_{REF} Output Tempco	$I_{OUT} = 0$			±5		ppm/ $^\circ\text{C}$
Internal Reference Source Current				1		μA
External Reference Voltage for Specified Linearity	(Notes 9, 10)		2.30	2.50	2.70	V
External Reference Current Drain	Ext. Reference = 2.5V (Note 9)				100	μA
CAP Output Voltage	$I_{OUT} = 0$			4.096		V

DIGITAL INPUTS AND DIGITAL OUTPUTS

The ● indicates specifications which apply over the full operating temperature range, otherwise specifications are at $T_A = 25^\circ\text{C}$. (Note 5)

SYMBOL	PARAMETER	CONDITIONS	LTC1606/LTC1606A			UNITS
			MIN	TYP	MAX	
V_{IH}	High Level Input Voltage	$V_{DD} = 5.25\text{V}$	●	2.4		V
V_{IL}	Low Level Input Voltage	$V_{DD} = 4.75\text{V}$	●		0.8	V
I_{IN}	Digital Input Current	$V_{IN} = 0\text{V to } V_{DD}$	●		± 10	μA
C_{IN}	Digital Input Capacitance			5		pF
V_{OH}	High Level Output Voltage	$V_{DD} = 4.75\text{V}$	$I_O = -10\mu\text{A}$		4.5	V
			$I_O = -200\mu\text{A}$	●	4.0	V
V_{OL}	Low Level Output Voltage	$V_{DD} = 4.75\text{V}$	$I_O = 160\mu\text{A}$		0.05	V
			$I_O = 1.6\text{mA}$	●	0.10	0.4
I_{OZ}	Hi-Z Output Leakage D15 to D0	$V_{OUT} = 0\text{V to } V_{DD}$, $\overline{\text{CS}}$ High	●		± 10	μA
C_{OZ}	Hi-Z Output Capacitance D15 to D0	$\overline{\text{CS}}$ High (Note 9)	●		15	pF
I_{SOURCE}	Output Source Current	$V_{OUT} = 0\text{V}$		-10		mA
I_{SINK}	Output Sink Current	$V_{OUT} = V_{DD}$		10		mA

TIMING CHARACTERISTICS

The ● indicates specifications which apply over the full operating temperature range, otherwise specifications are at $T_A = 25^\circ\text{C}$. (Note 5)

SYMBOL	PARAMETER	CONDITIONS	LTC1606/LTC1606A			UNITS
			MIN	TYP	MAX	
$f_{SAMPLE(MAX)}$	Maximum Sampling Frequency		●	250		kHz
t_{CONV}	Conversion Time		●		2.5	μs
t_{ACQ}	Acquisition Time		●		1.5	μs
t_1	Convert Pulse Width	(Note 11)	●	40		ns
t_2	Data Valid Delay After $R/\overline{\text{C}}\downarrow$	(Note 9)	●		2.5	μs
t_3	$\overline{\text{BUSY}}$ Delay from $R/\overline{\text{C}}\downarrow$	$C_L = 30\text{pF}$	●		65	ns
t_4	$\overline{\text{BUSY}}$ Low		●		2.5	μs
t_5	$\overline{\text{BUSY}}$ Delay After End of Conversion			100		ns
t_6	Aperture Delay			40		ns
t_7	Bus Relinquish Time		●	15	50	ns
t_8	$\overline{\text{BUSY}}$ Delay After Data Valid		●	20	90	ns
t_9	Previous Data Valid After $R/\overline{\text{C}}\downarrow$			2		μs
t_{10}	$R/\overline{\text{C}}$ to $\overline{\text{CS}}$ Setup Time	(Notes 9, 10)	●	5		ns
t_{11}	Time Between Conversions		●	4		μs
t_{12}	Bus Access	$C_L = 30\text{pF}$	●	15	60	ns
	Byte Delay	$C_L = 30\text{pF}$ (Notes 9, 10)	●	15	60	ns

POWER REQUIREMENTS

The ● indicates specifications which apply over the full operating temperature range, otherwise specifications are at $T_A = 25^\circ\text{C}$. (Note 5)

SYMBOL	PARAMETER	CONDITIONS	LTC1606/LTC1606A			UNITS
			MIN	TYP	MAX	
V_{DD}	Positive Supply Voltage	(Notes 9, 10)	4.75		5.25	V
I_{DD}	Positive Supply Current			15	20	mA
P_{DIS}	Power Dissipation			75	100	mW

Note 1: Absolute Maximum Ratings are those values beyond which the life of a device may be impaired.

Note 2: All voltage values are with respect to ground with DGND, AGND1 and AGND2 wired together (unless otherwise noted).

Note 3: When these pin voltages are taken below ground or above $V_{ANA} = V_{DIG} = V_{DD}$, they will be clamped by internal diodes. This product can handle input currents of greater than 100mA below ground or above V_{DD} without latch-up.

Note 4: When these pin voltages are taken below ground, they will be clamped by internal diodes. This product can handle input currents of 90mA below ground without latchup. These pins are not clamped to V_{DD} .

Note 5: $V_{DD} = 5\text{V}$, $f_{SAMPLE} = 250\text{kHz}$, $t_r = t_f = 5\text{ns}$ unless otherwise specified.

Note 6: Linearity, offset and full-scale specifications apply for a V_{IN} input with respect to ground.

Note 7: Integral nonlinearity is defined as the deviation of a code from a straight line passing through the actual end points of the transfer curve. The deviation is measured from the center of the quantization band.

Note 8: Bipolar offset is the offset voltage measured from -0.5 LSB when the output code flickers between 0000 0000 0000 0000 and 1111 1111 1111 1111.

Note 9: Guaranteed by design, not subject to test.

Note 10: Recommended operating conditions.

Note 11: With \overline{CS} low the falling R/\overline{C} edge starts a conversion. If R/\overline{C} returns high at a critical point during the conversion, it can create errors. For best results, ensure that R/\overline{C} returns high within $1\mu\text{s}$ after the start of the conversion.

Note 12: As measured with fixed resistors shown in Figure 4. Adjustable to zero with external potentiometer.

Note 13: Full-scale error is the worst-case of $-FS$ or $+FS$ untrimmed deviation from ideal first and last code transitions, divided by the transition voltage (not divided by the full-scale range) and includes the effect of offset error.

Note 14: All specifications in dB are referred to a full-scale $\pm 10\text{V}$ input.

Note 15: Full-power bandwidth is defined as full-scale input frequency at which a signal-to-(noise + distortion) degrades to 60dB or 10 bits of accuracy.

Note 16: Recovers to specified performance after $(2 \cdot FS)$ input overvoltage.

TYPICAL PERFORMANCE CHARACTERISTICS

Supply Current vs Supply Voltage

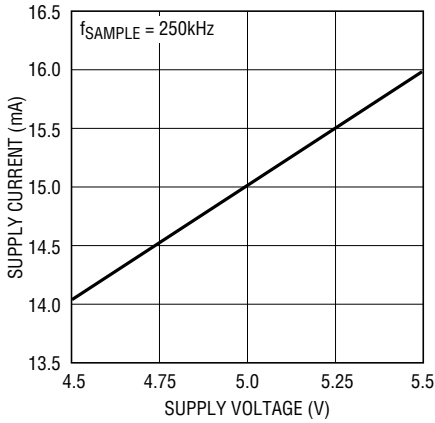

1606 G01

Supply Current vs Temperature

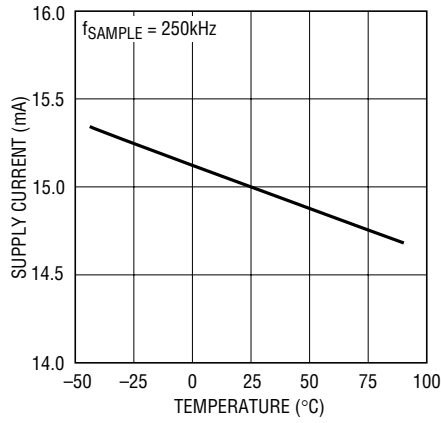

1606 G02

Change in CAP Voltage vs Load Current

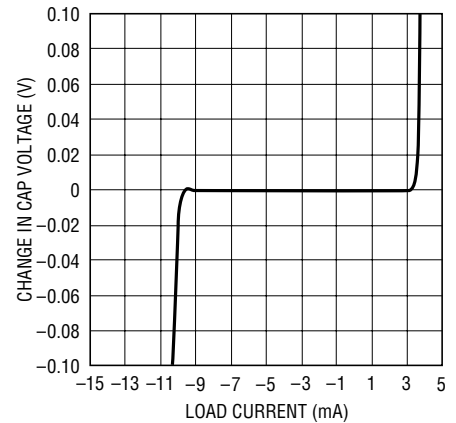

1606 G03

Typical INL Curve

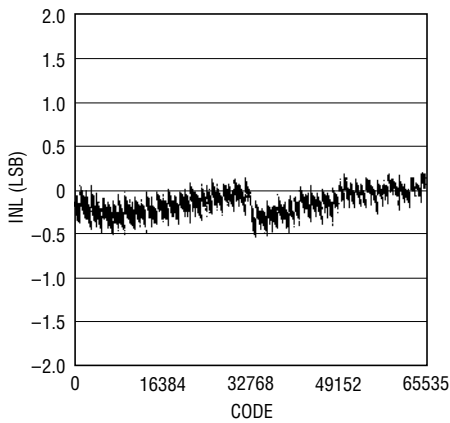

1606 G04

Typical DNL Curve

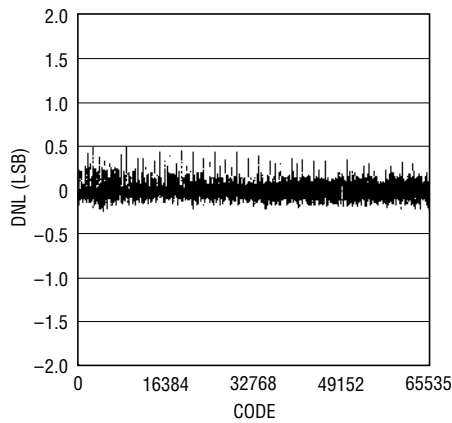

1606 G04

Power Supply Rejection vs Ripple Frequency

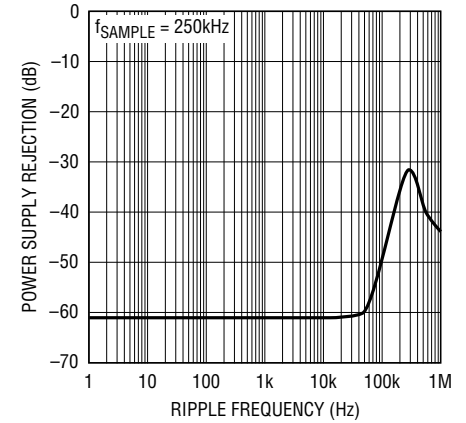

LT1606 G06

Nonaveraged 4096 Point FFT Plot

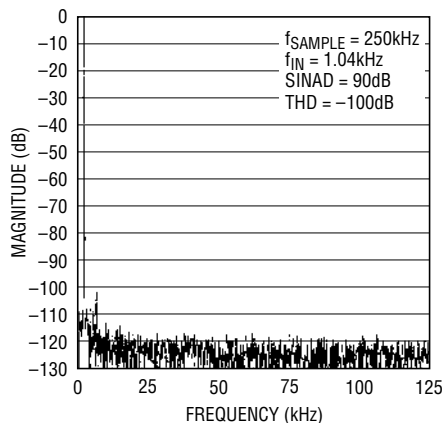

1606 G07

SINAD vs Input Frequency

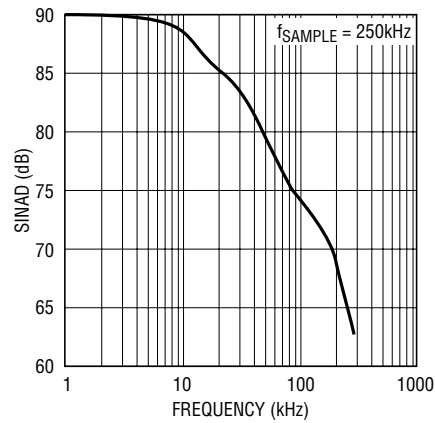

1606 G08

Total Harmonic Distortion (THD) vs Input Frequency

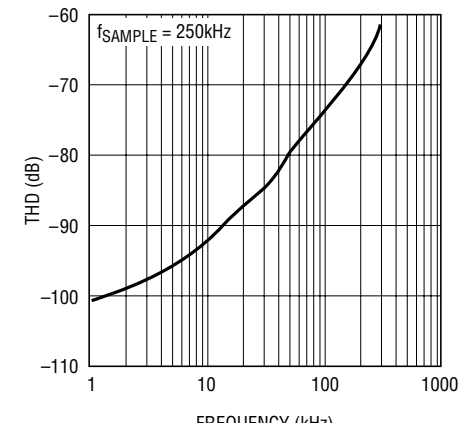

1606 G09

PIN FUNCTIONS

V_{IN} (Pin 1): Analog Input. Connect through a 200Ω resistor to the analog input. Full-scale input range is ±10V.

AGND1 (Pin 2): Analog Ground. Tie to analog ground plane.

REF (Pin 3): 2.5V Reference Output. Bypass with 2.2μF tantalum capacitor. Can be driven with an external reference.

CAP (Pin 4): Reference Buffer Output. Bypass with 10μF tantalum capacitor. The capacitor output voltage is 4.096V when REF = 2.5V.

AGND2 (Pin 5): Analog Ground. Tie to analog ground plane.

D15 to D8 (Pins 6 to 13): Three-State Data Outputs. Hi-Z state when \overline{CS} is high or when $\overline{R/C}$ is low.

DGND (Pin 14): Digital Ground.

D7 to D0 (Pins 15 to 22): Three-State Data Outputs. Hi-Z state when \overline{CS} is high or when $\overline{R/C}$ is low.

BYTE (Pin 23): Byte Select. With BYTE low, data will be output with Pin 6 (D15) being the MSB and Pin 22 (D0)

being the LSB. With BYTE high, the upper eight bits and the lower eight bits will be switched. The MSB is output on Pin 15 and bit 8 is output on Pin 22. Bit 7 is output on Pin 6 and the LSB is output on Pin 13.

R/C (Pin 24): Read/Convert Input. With \overline{CS} low, a falling edge on $\overline{R/C}$ puts the internal sample-and-hold into the hold state and starts a conversion. With \overline{CS} low, a rising edge on $\overline{R/C}$ enables the output data bits.

CS (Pin 25): Chip Select. Internally OR'd with $\overline{R/C}$. With $\overline{R/C}$ low, a falling edge on \overline{CS} will initiate a conversion. With $\overline{R/C}$ high, a falling edge on \overline{CS} will enable the output data.

BUSY (Pin 26): Output Shows Converter Status. It is low when a conversion is in progress. Data valid on the rising edge of \overline{BUSY} . \overline{CS} or $\overline{R/C}$ must be high when \overline{BUSY} rises or another conversion will start without time for signal acquisition.

V_{ANA} (Pin 27): 5V Analog Supply. Bypass to ground with a 0.1μF ceramic and a 10μF tantalum capacitor.

V_{DIG} (Pin 28): 5V Digital Supply. Connect directly to Pin 27.

FUNCTIONAL BLOCK DIAGRAM

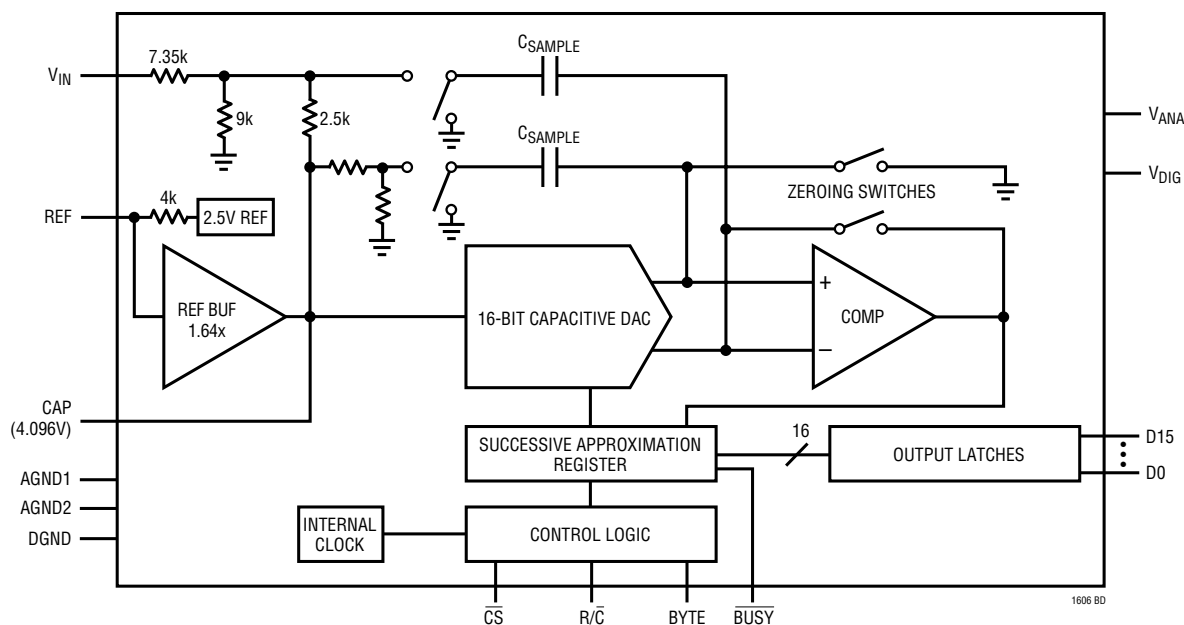

1606fa

TEST CIRCUITS

Load Circuit for Access Timing

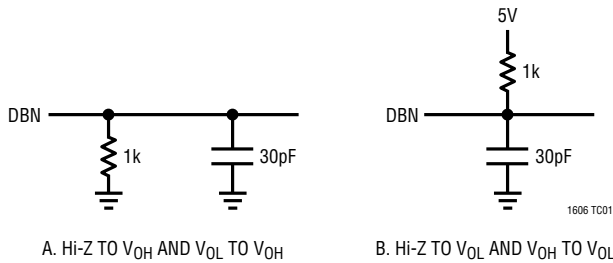

Load Circuit for Output Float Delay

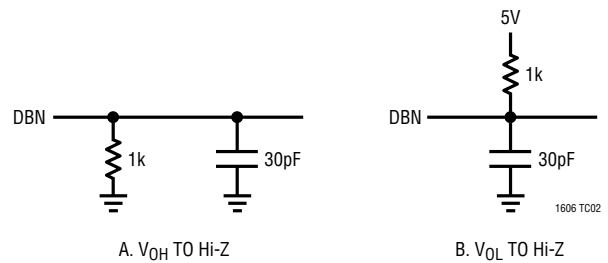

APPLICATIONS INFORMATION

Conversion Details

The LTC1606 uses a successive approximation algorithm and an internal sample-and-hold circuit to convert an analog signal to a 16-bit or two byte parallel output. The ADC is complete with a precision reference and an internal clock. The control logic provides easy interface to microprocessors and DSPs. (Please refer to the Digital Interface section for the data format.)

Conversion start is controlled by the \overline{CS} and R/\overline{C} inputs. At the start of conversion, the successive approximation register (SAR) is reset. Once a conversion cycle has begun, it cannot be restarted.

During the conversion, the internal 16-bit capacitive DAC output is sequenced by the SAR from the most significant bit (MSB) to the least significant bit (LSB). Referring to Figure 1, V_{IN} is connected through the resistor divider to

the sample-and-hold capacitor during the acquire phase and the comparator offset is nulled by the autozero switches. In this acquire phase, a minimum delay of $1.5\mu s$ will provide enough time for the sample-and-hold capacitor to acquire the analog signal. During the convert phase, the autozero switches open, putting the comparator into the compare mode. The input switch switches C_{SAMPLE} to ground, injecting the analog input charge onto the summing junction. This input charge is successively compared with the binary-weighted charges supplied by the capacitive DAC. Bit decisions are made by the high speed comparator. At the end of a conversion, the DAC output balances the V_{IN} input charge. The SAR contents (a 16-bit data word) that represents the V_{IN} are loaded into the 16-bit output latches.

Driving the Analog Inputs

The nominal input range for the LTC1606 is $\pm 10V$ or $(\pm 4 \cdot V_{REF})$ and the input is overvoltage protected to $\pm 25V$. The input impedance is typically $10k\Omega$, therefore, it should be driven with a low impedance source. Wideband noise coupling into the input can be minimized by placing a $1000pF$ capacitor at the input as shown in Figure 2. An NPO-type capacitor gives the lowest distortion. Place the

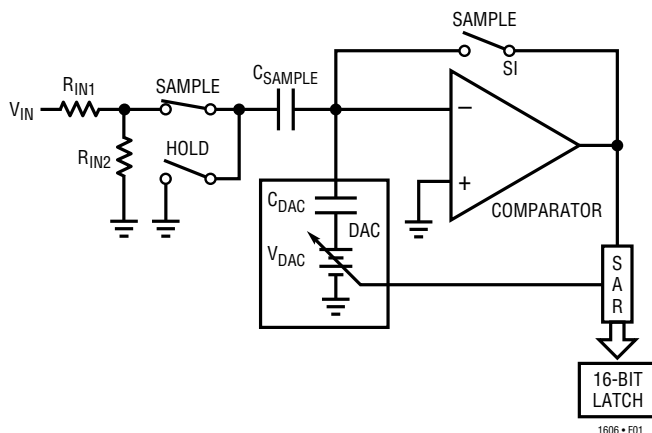

Figure 1. LTC1606 Simplified Equivalent Circuit

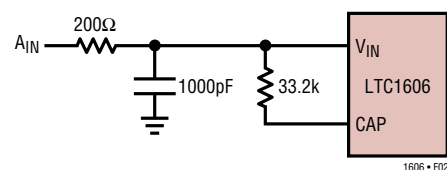

Figure 2. Analog Input Filtering

APPLICATIONS INFORMATION

capacitor as close to the device input pin as possible. If an amplifier is to be used to drive the input, care should be taken to select an amplifier with adequate accuracy, linearity and noise for the application. The following list is a summary of the op amps that are suitable for driving the LTC1606. More detailed information is available in the Linear Technology data books and LinearView™ CD-ROM.

LT1007: Low noise precision amplifier. 2.7mA supply current $\pm 5V$ to $\pm 15V$ supplies. Gain bandwidth product 8MHz. DC applications.

LT1097: Low cost, low power precision amplifier. 300 μA supply current. $\pm 5V$ to $\pm 15V$ supplies. Gain bandwidth product 0.7MHz. DC applications.

LT1227: 140MHz video current feedback amplifier. 10mA supply current. $\pm 5V$ to $\pm 15V$ supplies. Low noise and low distortion.

LT1360: 37MHz voltage feedback amplifier. 3.8mA supply current. $\pm 5V$ to $\pm 15V$ supplies. Good AC/DC specs.

LT1363: 50MHz voltage feedback amplifier. 6.3mA supply current. Good AC/DC specs.

LT1364/LT1365: Dual and quad 50MHz voltage feedback amplifiers. 6.3mA supply current per amplifier. Good AC/DC specs.

LT1468: 90MHz 22V/ μs 16-bit accurate amplifier.

LT1469: Dual LT1468

Internal Voltage Reference

The LTC1606 has an on-chip, temperature compensated, curvature corrected, bandgap reference, which is factory trimmed to 2.50V. The full-scale range of the ADC is equal to $(\pm 4 \cdot V_{REF})$ or nominally $\pm 10V$. The output of the reference is connected to the input of a buffer (1.64x) through a 4k resistor (see Figure 3). The input to the buffer or the output of the reference is available at REF (Pin 3). The internal reference can be overdriven with an external reference if more accuracy is needed. The buffer output drives the internal DAC and is available at CAP (Pin 4). The CAP pin can be used to drive a steady DC load of less than 2mA. Driving an AC load is not recommended because it can cause the performance of the converter to degrade.

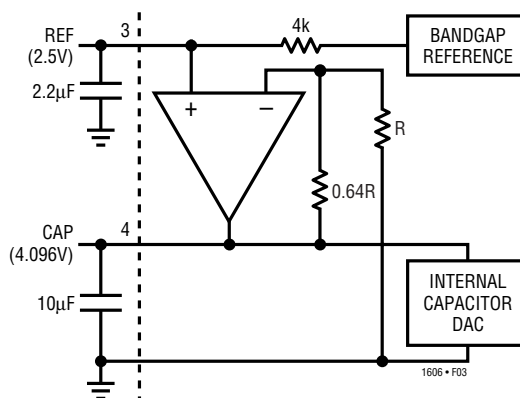

Figure 3. Internal or External Reference Source

For minimum code transition noise, the REF pin and the CAP pin should each be decoupled with a capacitor to filter wideband noise from the reference and the buffer (2.2 μF tantalum for the REF pin and 10 μF tantalum for the CAP pin). To prevent the 10 μF bypass capacitor from discharging through the CAP pin if the positive supply (V_{DIG} and V_{ANA}) were to drop, a diode (1N4148 or equivalent) can be placed between the CAP pin and the positive supply.

Offset and Gain Adjustments

The LTC1606 offset and full-scale errors have been trimmed at the factory with the external resistors shown in Figure 4. This allows for external adjustment of offset and full scale in applications where absolute accuracy is important. See Figure 5 for the offset and gain trim circuit. The 100k resistor in parallel with the 33.2k is only needed for externally trimming the offset. First, adjust the offset to zero by adjusting resistor R3. Apply an input voltage of $-152.6\mu V$ ($-0.5LSB$) and adjust R3 so the code is

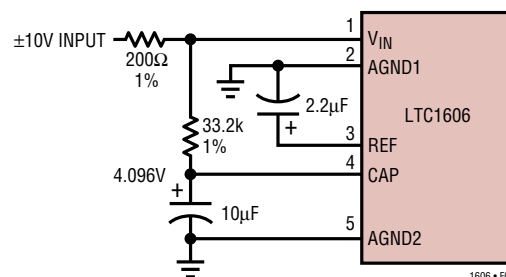

Figure 4. $\pm 10V$ Input Without Trim

APPLICATIONS INFORMATION

changing between 1111 1111 1111 1111 and 0000 0000 0000 0000. The gain error is trimmed by adjusting resistor R4. An input voltage of 9.999542V (+FS – 1.5LSB) is applied to V_{IN} and R4 is adjusted until the output code is changing between 0111 1111 1111 1110 and 0111 1111 1111 1111. Figure 6 shows the bipolar transfer characteristic of the LTC1606.

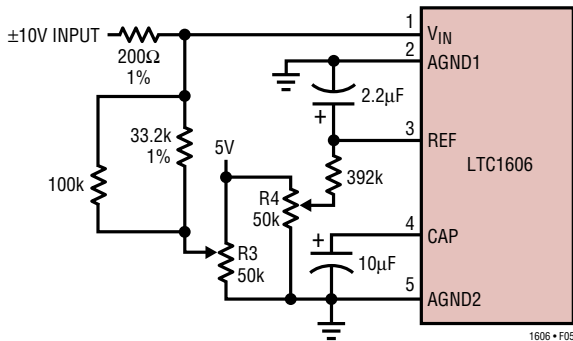

Figure 5. ±10V Input with Offset and Gain Trim

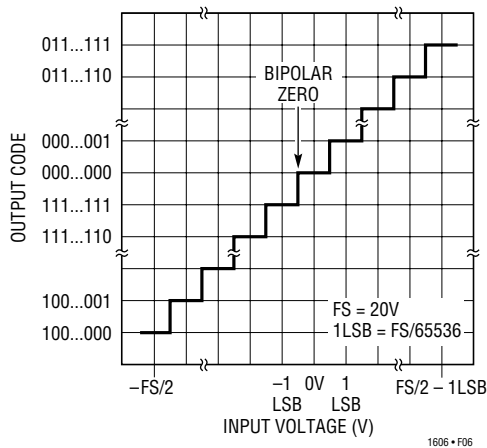

Figure 6. LTC1606 Bipolar Transfer Characteristics

If the external resistors are not used, the resulting offset and gain error ranges are shown in Table 1.

DC Performance

One way of measuring the transition noise associated with a high resolution ADC is to use a technique where a DC signal is applied to the input of the ADC and the resulting output codes are collected over a large number of conversions. For example in Figure 7, the distribution of output code is shown for a DC input that has been digitized 4096 times. The distribution is Gaussian and the RMS code transition is about 0.65LSB.

DIGITAL INTERFACE

Internal Clock

The ADC has an internal clock that is trimmed to achieve a typical conversion time of 2.3μs. No external adjustments are required and, with the typical acquisition time of 1μs, throughput performance of 250ksps is assured.

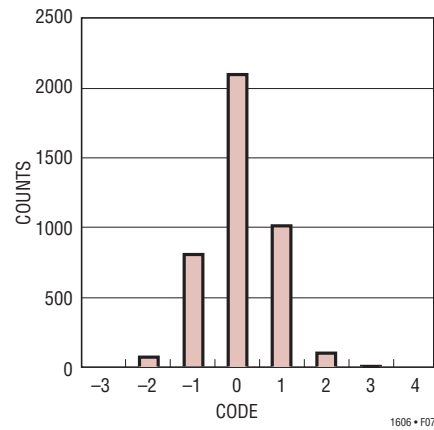

Figure 7. Histogram for 4096 Conversions

Table 1

ERROR TERM	WITH BOTH EXTERNAL RESISTORS INCLUDED	WITHOUT THE EXTERNAL 33.2k RESISTOR	WITHOUT EITHER EXTERNAL RESISTOR INCLUDED
Offset Error	-10mV < Error < 10mV	10mV < Error < 55mV	54mV < Error < 155mV
+ Full-Scale Error	-0.25% < Error < 0.25% -0.50% < Error < 0.50%	-1.3% < Error < -0.10%	-3.40% < Error < -0.85%
- Full-Scale Error	-0.25% < Error < 0.25% -0.50% < Error < 0.50%	0.25% < Error < 1.40%	2.10% < Error < 6.15%

APPLICATIONS INFORMATION

Timing and Control

Conversion start and data read are controlled by two digital inputs: \overline{CS} and R/\overline{C} . To start a conversion and put the sample-and-hold into the hold mode, bring \overline{CS} and R/\overline{C} low for no less than 40ns. Once initiated, it cannot be restarted until the conversion is complete. Converter status is indicated by the \overline{BUSY} output and this is low while the conversion is in progress.

There are two modes of operation. The first mode is shown in Figure 8. The digital input R/\overline{C} is used to control the start of conversion. \overline{CS} is tied low. When R/\overline{C} goes low, the sample-and-hold goes into the hold mode and a conversion is started. \overline{BUSY} goes low and stays low during the conversion and will go back high after the conversion has been completed and the internal output shift registers have been updated. R/\overline{C} should remain low for no less than 40ns. During the time R/\overline{C} is low, the digital outputs are in a Hi-Z state. R/\overline{C} should be brought back high within 1 μ s after the start of the conversion to ensure that no errors occur in the digitized result. The second mode, shown in

Figure 9, uses the \overline{CS} signal to control the start of a conversion and the reading of the digital output. In this mode the R/\overline{C} input signal should be brought low no less than 10ns before the falling edge of \overline{CS} . The minimum pulse width for \overline{CS} is 40ns. When \overline{CS} falls, \overline{BUSY} goes low and will stay low until the end of the conversion. \overline{BUSY} will go high after the conversion has been completed. The new data is valid when \overline{CS} is brought back low again to initiate a read. Again, it is recommended that both R/\overline{C} and \overline{CS} return high within 1 μ s after the start of the conversion.

Output Data

The output data can be read as a 16-bit word or it can be read as two 8-bit bytes. The format of the output data is two's complement. The digital input pin $BYTE$ is used to control the two byte read. With the $BYTE$ pin low, the first eight MSBs are output on the D15 to D8 pins and the eight LSBs are output on the D7 to D0 pins. When the $BYTE$ pin is taken high, the eight LSBs replace the eight MSBs (Figure 10).

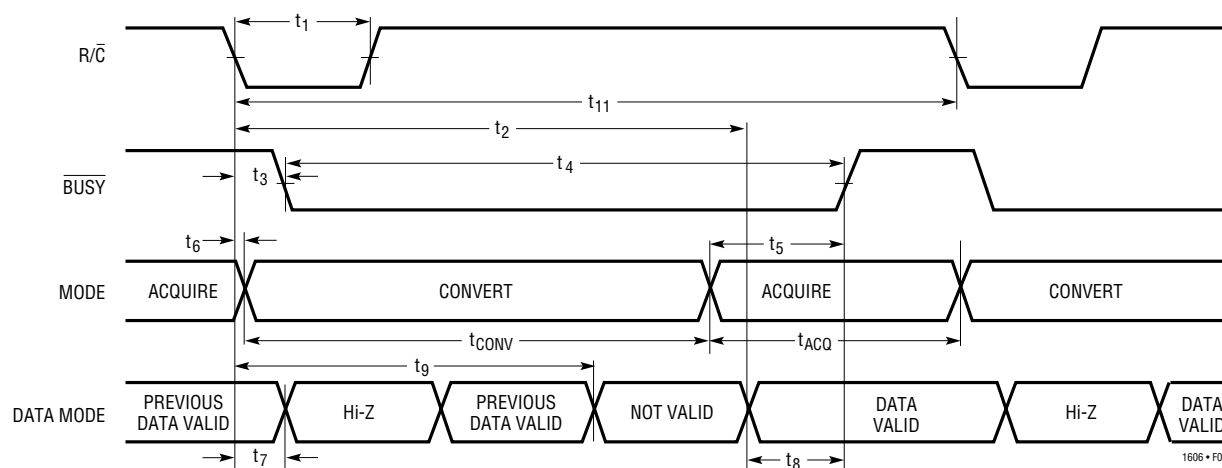

Figure 8. Conversion Timing with Outputs Enabled After Conversion (\overline{CS} Tied Low)

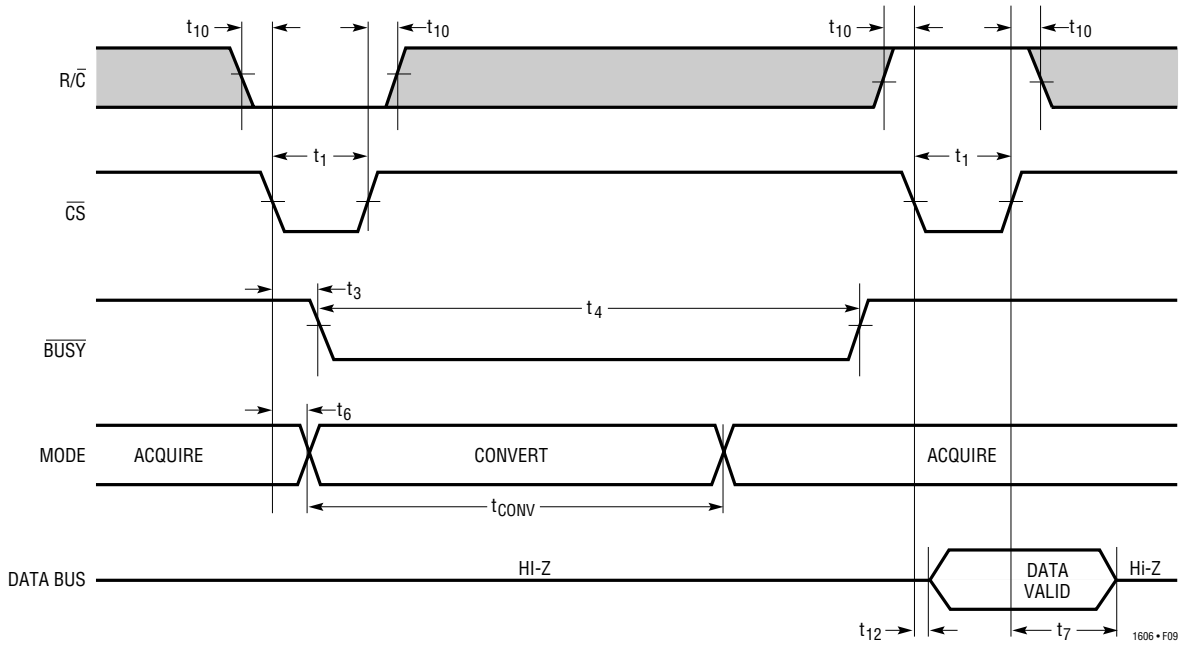

Figure 9. Using \overline{CS} to Control Conversion and Read Timing

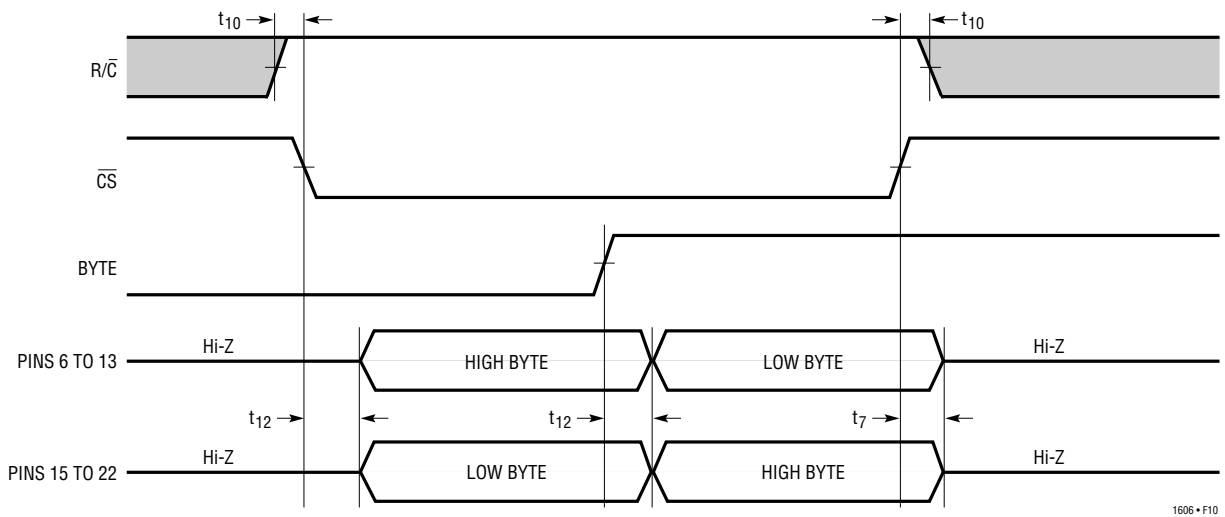

Figure 10. Using \overline{CS} and BYTE to Control Data Bus Read Timing

APPLICATIONS INFORMATION

Dynamic Performance

FFT (Fast Fourier Transform) test techniques are used to test the ADC's frequency response, distortion and noise at the rated throughput. By applying a low distortion sine wave and analyzing the digital output using an FFT algorithm, the ADC's spectral content can be examined for frequencies outside the fundamental.

Signal-to-Noise Ratio

The Signal-to-Noise and Distortion Ratio (SINAD) is the ratio between the RMS amplitude of the fundamental input frequency to the RMS amplitude of all other frequency components at the A/D output. The output is band limited to frequencies from above DC and below half the sampling frequency. A typical LTC1606 has a SINAD of 90dB and THD of -100dB with a 250kHz sampling rate and a 1kHz input.

Total Harmonic Distortion

Total Harmonic Distortion (THD) is the ratio of the RMS sum of all harmonics of the input signal to the fundamental itself. The out-of-band harmonics alias into the frequency band between DC and half the sampling frequency. THD is expressed as:

$$\text{THD} = 20 \log \frac{\sqrt{V_2^2 + V_3^2 + V_4^2 \dots + V_N^2}}{V_1}$$

where V_1 is the RMS amplitude of the fundamental frequency and V_2 through V_N are the amplitudes of the second through Nth harmonics.

Board Layout, Power Supplies and Decoupling

Wire wrap boards and molded sockets are not recommended for high resolution or high speed A/D converters. To obtain the best performance from the LTC1606, a printed circuit board is required. Layout for the printed circuit board should ensure the digital and analog signal lines are separated as much as possible. In particular, care should be taken not to run any digital track alongside an analog signal track or underneath the ADC. The analog input should be screened by AGND.

Pay particular attention to the design of the analog and digital ground planes. The DGND pin of the LTC1606 should be tied to the analog ground plane. Placing the bypass capacitor as close as possible to the power supply, the reference and reference buffer output is very important. Low impedance common returns for these bypass capacitors are essential to low noise operation of the ADC, and the foil width for these tracks should be as wide as possible. Also, since any potential difference in grounds between the signal source and ADC appears as an error voltage in series with the input signal, attention should be paid to reducing the ground circuit impedance as much as possible.

PACKAGE DESCRIPTION Dimensions in inches (millimeters) unless otherwise noted.

G Package
28-Lead Plastic SSOP (0.209)
 (LTC DWG # 05-08-1640)

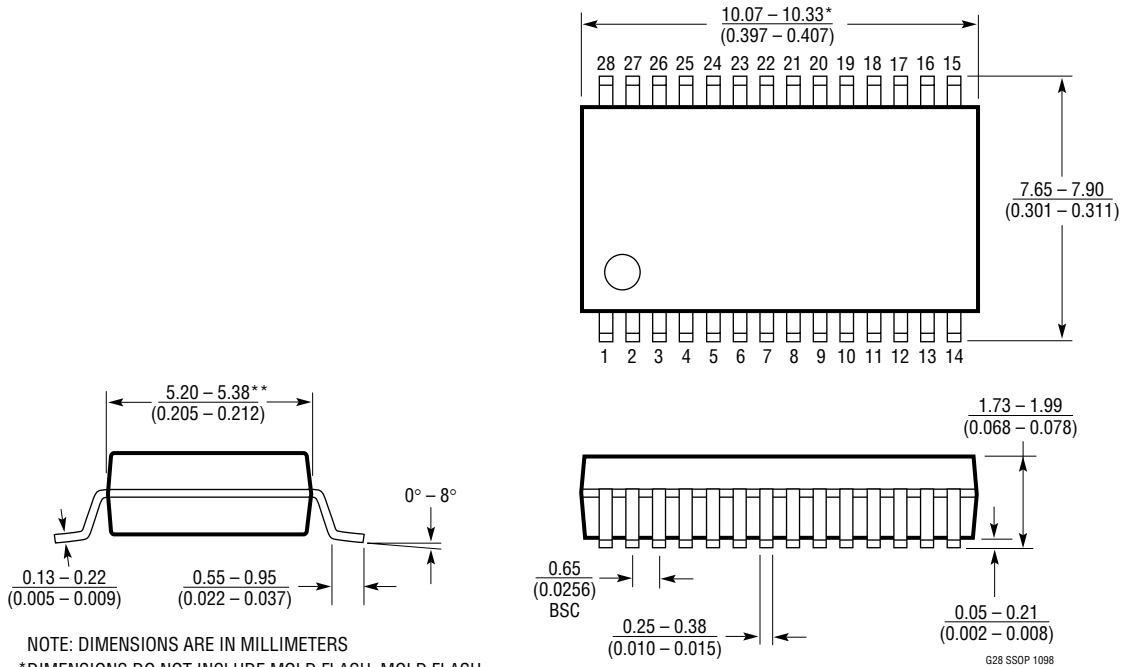

NOTE: DIMENSIONS ARE IN MILLIMETERS
 *DIMENSIONS DO NOT INCLUDE MOLD FLASH. MOLD FLASH SHALL NOT EXCEED 0.152mm (0.006") PER SIDE
 **DIMENSIONS DO NOT INCLUDE INTERLEAD FLASH. INTERLEAD FLASH SHALL NOT EXCEED 0.254mm (0.010") PER SIDE

PACKAGE DESCRIPTION Dimensions in inches (millimeters) unless otherwise noted.

SW Package
28-Lead Plastic Small Outline (Wide 0.300)
 (LTC DWG # 05-08-1620)

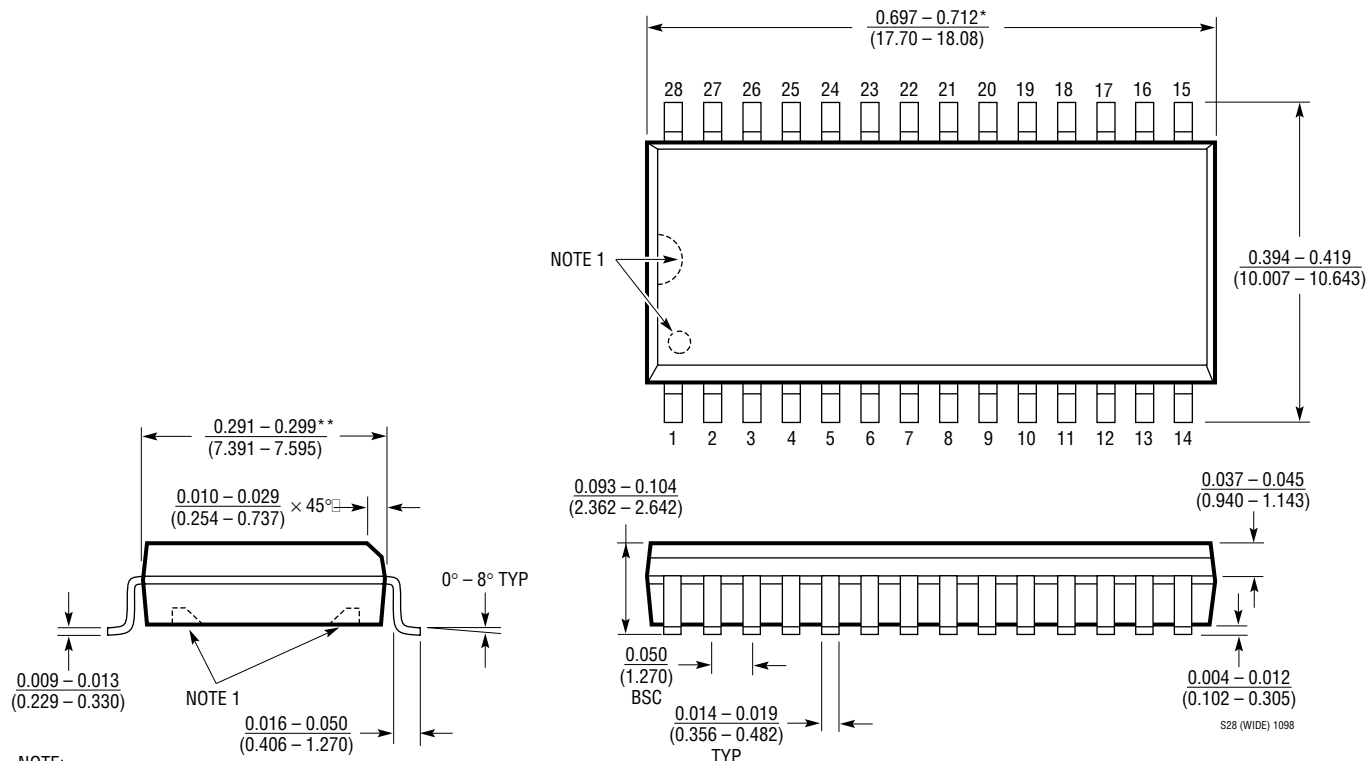

NOTE:
 1. PIN 1 IDENT, NOTCH ON TOP AND CAVITIES ON THE BOTTOM OF PACKAGES ARE THE MANUFACTURING OPTIONS.
 THE PART MAY BE SUPPLIED WITH OR WITHOUT ANY OF THE OPTIONS
 *DIMENSION DOES NOT INCLUDE MOLD FLASH. MOLD FLASH SHALL NOT EXCEED 0.006" (0.152mm) PER SIDE
 **DIMENSION DOES NOT INCLUDE INTERLEAD FLASH. INTERLEAD FLASH SHALL NOT EXCEED 0.010" (0.254mm) PER SIDE

TYPICAL APPLICATION

High Impedance Buffered Input Exhibits 100dB SFDR and 98dB THD Performance

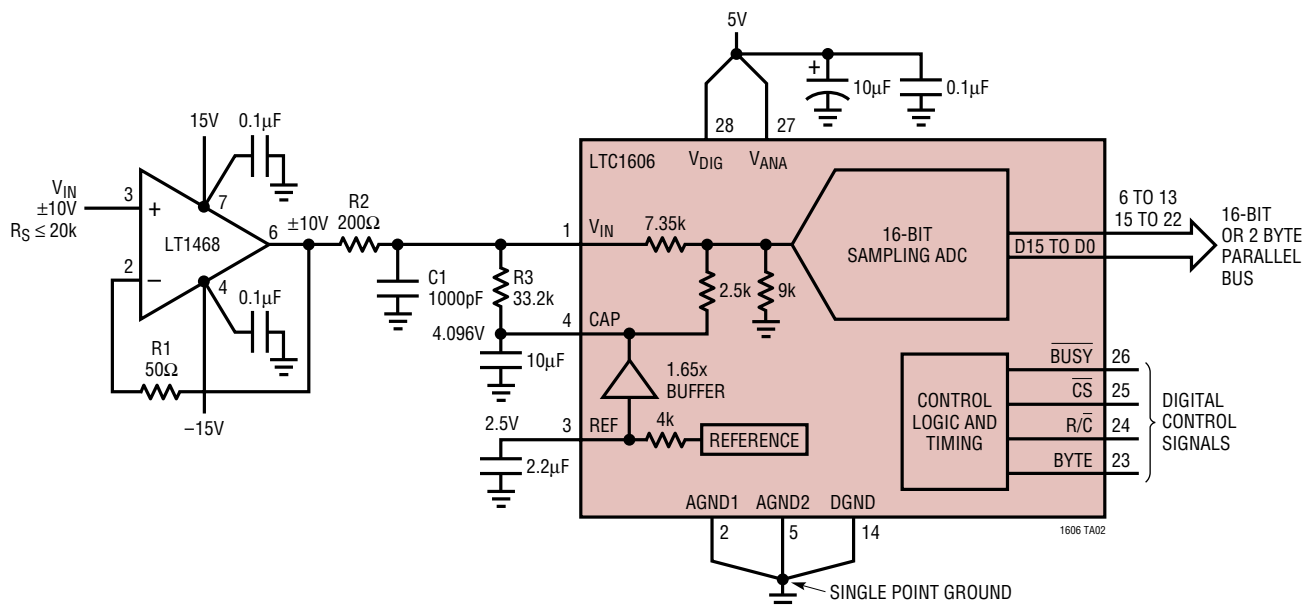

RELATED PARTS

PART NUMBER	DESCRIPTION	COMMENTS
LTC1274/LTC1277	Low Power 12-Bit, 100ksps ADCs	10mW Power Dissipation, Parallel/Byte Interface
LTC1415	Single 5V, 12-Bit, 1.25Msps ADC	55mW Power Dissipation, 72dB SINAD
LTC1418	14-Bit, 200ksps ADC	15mW, Serial or Parallel Interface
LTC1419	Low Power 14-Bit, 800ksps ADC	True 14-Bit Linearity, 81.5dB SINAD, 150mW Dissipation
LT1460-2.5	Micropower Precision Series Reference	0.075% Max, 10ppm/°C Max, Only 130μA Supply Current
LT1461	Precision Bandgap Reference	0.04% Max, 3ppm/°C Max
LTC1594/LTC1598	Micropower 4-/8-Channel 12-Bit ADCs	Serial I/O, 3V and 5V Versions
LTC1604	16-Bit, 333ksps ADC	±2.5V Input, 90dB SINAD, 100dB THD, No Missing Codes
LTC1605	16-Bit, 100kHz ADC	Pin Compatible with LTC1606
LTC1605-1/LTC1605-2	16-Bit, 100kHz ADC	0V to 4V/±4V Input Range, Pin Compatible with LTC1606
LTC1608	16-Bit, 500ksps ADC	±2.5V Input, No Missing Codes, Pin Compatible with LTC1604

Looking for pricing, stock, or lifecycle information?

Click below to explore more details on WIN SOURCE:

 [View LTC1606CSW#PBF on WIN SOURCE](#)

 [Linear Technology](#) Information

Optimize Your Supply Chain with WIN SOURCE Solutions

-  Global Sourcing Solution
-  Obsolete Management
-  Cost Control Management
-  Shortage Management
-  Alternative Solution
-  Excess Inventory Management