



**THE DATASHEET OF
LTC1697EMS#TRPBF**



FEATURES

- Operates from Single Li-Ion Battery
- 2.8V to 5.5V Input Voltage Range
- Very Low Shutdown Current: $<2\mu\text{A}$
- Synchronous Buck Architecture for High Efficiency
- PWM Dimming Frequency Adjustable with a Single Capacitor
- Accurate Lamp Current Maximizes Lamp Lifetime
- Fixed Frequency Operation at 300kHz
- Internal or External PWM Dimming
- Small 10-Pin MSOP Package

APPLICATIONS

- PDAs
- Handheld Computers
- Portable Instruments
- Handheld GPS with Map Display
- Handheld TV/Video Monitor

DESCRIPTION

The LTC[®]1697 is designed to control a single 1W cold cathode fluorescent lamp (CCFL). An internal PWM dimming system maximizes efficiency and dimming range. Accurate lamp currents can be set with a single external resistor.

The LTC1697 includes a synchronous current mode PWM controller with internal 1A MOSFET switches. It contains a 300kHz oscillator, 0.8V reference, and internal current sense. It operates from a 2.8V to 5.5V input voltage. The LTC1697 also has a thermal limit and a shutdown that reduces supply current to $<2\mu\text{A}$.

The LTC1697 is available in the MSOP-10 package.

LT, LTC and LT are registered trademarks of Linear Technology Corporation.
 Protected by U.S. Patent 6522116.

TYPICAL APPLICATION

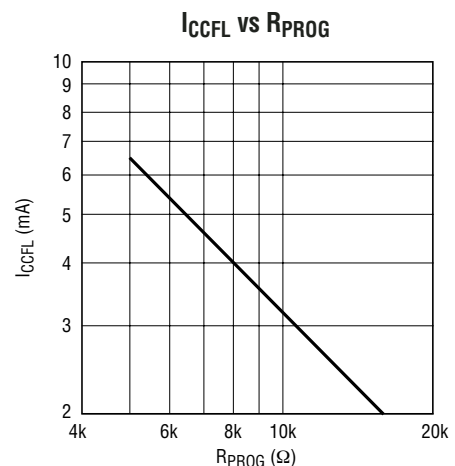
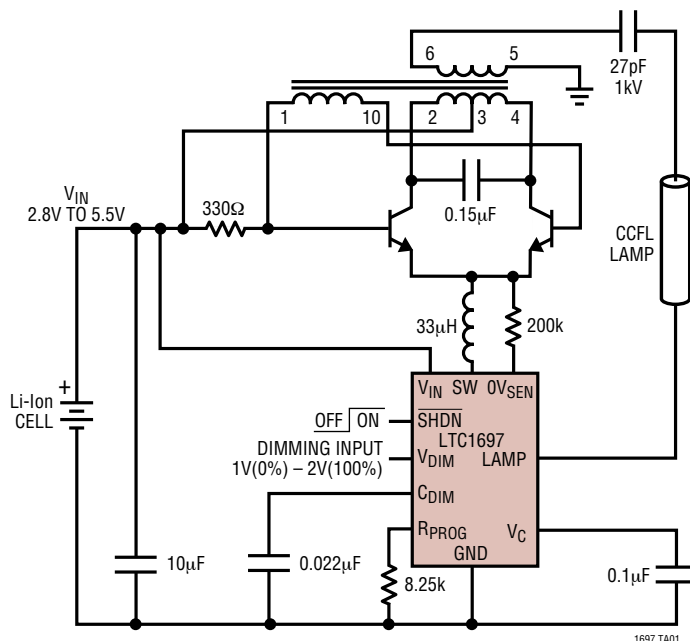

1967 TA01b

ABSOLUTE MAXIMUM RATINGS

(Notes 1, 2)

| | |
|---|------------------------------|
| V_{IN} Voltage | -0.5V to 6V |
| V_C , OV_{SEN} , C_{DIM} , R_{PROG} , SW Voltages | -0.5V to ($V_{IN} + 0.3V$) |
| $SHDN$, V_{DIM} Pins | -0.5V to 6V |
| LAMP Pin | -0.5V to 0.5V |
| Operating Temperature Range (Note 5) | -40°C to 85°C |
| Storage Temperature Range | -65°C to 125°C |
| Lead Temperature (Soldering, 10 sec) | 300°C |

PACKAGE/ORDER INFORMATION

| | |
|--|-------------------|
| | ORDER PART NUMBER |
| | LTC1697EMS |
| | MS PART MARKING |
| | LTZR |

Consult LTC Marketing for parts specified with wider operating temperature ranges.

ELECTRICAL CHARACTERISTICS

The ● denotes the specifications which apply over the full operating temperature range, otherwise specifications are at $T_A = 25^\circ\text{C}$. $2.8V < V_{IN} \leq 5.5V$ unless otherwise specified.

| SYMBOL | PARAMETER | CONDITIONS | MIN | TYP | MAX | UNITS | |
|-----------------|--|---|--------|------------|---------|---------------|---------------|
| V_{IN} | Operating Supply Voltage Range | (Note 2) | ● 2.8 | | 5.5 | V | |
| V_{UVLO} | Undervoltage Lockout | | | | 2.77 | V | |
| I_{Q-SHDN} | Quiescent Current - \overline{SHDN} | $\overline{SHDN} = 0V$; $V_{DIM} = 0V$ | | 1 | 2 | μA | |
| $I_{Q-Active}$ | Quiescent Current - Active | $V_C = 0V$, $\overline{SHDN} = V_{IN} = V_{DIM} = 4.2V$ (Note 4) | | 0.9 | 1.5 | mA | |
| I_{LEAK} | Switch Leakage | | | 0.1 | 1 | μA | |
| R_{ON} | Switch On Resistance | $V_{IN} = 4V$ | | 0.18 | | Ω | |
| I_{MAX} | Switch Current Limit | | ● 0.9 | 1.6 | | A | |
| % DC | Duty Cycle | | ● 0 | | 95 | % | |
| f_{SWITCH} | Switching Frequency | | ● 240 | 300 | 370 | kHz | |
| f_{DIM} | Dimming PWM Frequency | $C_{DIM} = 0.022\mu\text{F}$ (Note 3) | ● 190 | 250 | 310 | Hz | |
| V_{DIM} | V_{DIM} Input Voltage | Dimming PWM Duty Cycle = 0% Dimming PWM Duty Cycle = 100% | | 1.0 2.0 | | V V | |
| I_{DIM} | V_{DIM} Input Bias Current | $V_{DIM} = 2V$ | | | ± 1 | μA | |
| R_{LAMP} | Internal R_{LAMP} Resistance | LAMP Pin to GND | | 50 | 60 | Ω | |
| $I_{L(ERROR)}$ | Lamp Current Accuracy | $ 1 - I_{LAMP(AVG)}/(32/6.4k) \cdot 100\%$ (Note 6) $I_{LAMP} = 5\text{mA}$ | ● | 2 | 6 | % | |
| $R_{P(RANGE)}$ | Programming Resistor Range | (Note 10) | ● 6.4 | | 16 | k Ω | |
| V_{SHDN-H} | \overline{SHDN} Input High | | 1.2 | | | V | |
| V_{SHDN-L} | \overline{SHDN} Input Low (Note 9) | | | | 0.4 | V | |
| I_{SHDN} | \overline{SHDN} Input Current | $V_{SHDN} = V_{IN}$ | ● | 0.1 | 1 | μA | |
| I_{OVSEN} | Overvoltage Sense Protect Current (Note 7) | $I_{LAMP} = 5\text{mA}$, $R_{PROG} = 6.4k$ | ● | 16.65 | 21.5 | 26.35 | μA |
| V_{OVSEN} | Overvoltage Sense Pin Voltage | | ● 0.95 | 1.2 | 1.5 | V | |
| $V_{DIM(SD-L)}$ | Passive Shutdown Voltage (Note 8) | | ● | | 0.4 | V | |
| $V_{DIM(SD-H)}$ | Not in Passive Shutdown | | ● 1.05 | | | V | |

ELECTRICAL CHARACTERISTICS

Note 1: Absolute Maximum Ratings are those values beyond which the life of a device may be impaired.

Note 2: All voltages specified with respect to GND pin.

Note 3: The dimming PWM frequency is set by the equation $5\text{Hz}/C_{\text{DIM}}(\mu\text{F})$.

Note 4: Actual operating current will be higher due to lamp operating current.

Note 5: The LTC1697 is guaranteed to meet performance specifications from 0°C to 70°C. Specifications over the -40°C to 85°C operating temperature range are assured by design, characterization and correlation with statistical process controls.

Note 6: $I_{\text{LAMP(AVG)}}$ = the average of the magnitude (absolute value) of the positive and negative lamp current flowing into and out of the LAMP pin.

Note 7: For currents at or above $I_{\text{OVSEN(ON)}}$, the switch duty cycle will be 0%.

Note 8: At V_{DIM} voltages below $V_{\text{DIM(SHDN0N)}}$ the LTC1697 behaves as if the $\overline{\text{SHDN}}$ pin was pulled low.

Note 9: To minimize I_{Q} shutdown, pull the $\overline{\text{SHDN}}$ pin below 0.1V.

Note 10: $2\text{mA} \leq I_{\text{LAMP}} \leq 5\text{mA}$.

PIN FUNCTIONS

C_{DIM} (Pin 1): Dimming Capacitor. Connect the pin to GND with a 0.022 μF capacitor (nominal). The value of capacitance on the C_{DIM} pin determines the dimming PWM frequency. The transfer function of capacitance to frequency is $5\text{Hz}/C_{\text{DIM}}(\mu\text{F})$.

V_{DIM} (Pin 2): Dimming Control Pin. The V_{DIM} pin controls the duty cycle of the dimming PWM. It ranges from 0% at $V_{\text{DIM}} = 1\text{V}$ to 100% at $V_{\text{DIM}} = 2\text{V}$. If the V_{DIM} voltage is $<0.4\text{V}$ the LTC1697 will enter shutdown mode after $\approx 50\text{ms}$.

OV_{SEN} (Pin 3): Overvoltage Sense Pin. Protects the high-voltage transformer from the overvoltage condition that occurs when the lamp is open or not present. This pin is connected through a resistor to the emitters of the drive transistors of the Royer oscillator.

SW (Pin 4): Switch Pin. Connect the inductor and optional Schottky diode here. Minimize trace length to keep EMI and high frequency ringing down.

GND (Pin 5): Signal and Power Ground for the LTC1697.

LAMP (Pin 6): Lamp Current Feedback Pin. Connect this pin to the CCFL lamp.

V_{IN} (Pin 7): Input Supply Pin.

V_{C} (Pin 8): Compensation Node. Connect this pin to GND through a 0.1 μF capacitor. See Application Information section. A frequency compensation network is connected to this pin to compensate the loop. See the section “ V_{C} Compensation” for guidelines.

R_{PROG} (Pin 9): Lamp Current Programming. Connect this pin to GND with a 6.4k 1% resistor (nominal). See Application Information section for resistor selection.

$\overline{\text{SHDN}}$ (Pin 10): Shutdown. Grounding this pin shuts down the LTC1697. Tie to $>1\text{V}$ to enable.

BLOCK DIAGRAM

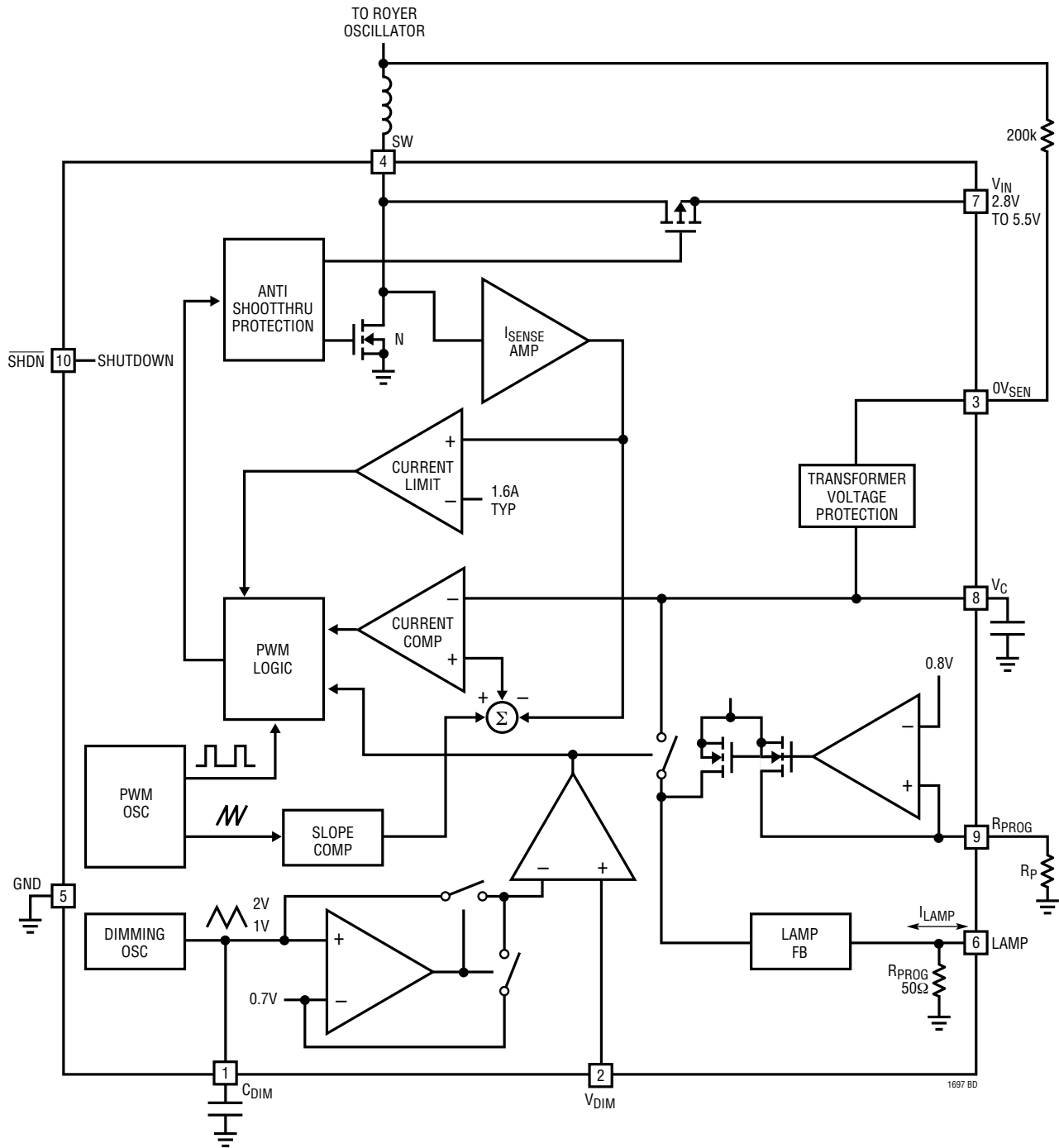

APPLICATIONS INFORMATION

Background

Current generation handheld computers and instruments typically use backlit liquid crystal displays (LCDs). Cold cathode fluorescent lamps (CCFLs) provide the highest available efficiency for backlighting the display, where providing the most light out for the least amount of input power is the most important goal. These lamps require high voltage AC to operate, mandating an efficient high voltage DC/AC converter. The lamps operate from DC, but migration effects damage the lamp and shorten its lifetime. Lamp drive should ideally contain zero DC component. In addition to good efficiency, the converter should deliver the lamp drive in the form of a sine wave. This minimizes EMI and RF emissions, which can interfere with other devices and degrade overall operating efficiency. Sinusoidal CCFL drive also maximizes current-to-light conversion in the lamp. The circuit also permits lamp intensity control from zero to full brightness with no hysteresis or “pop-on.”

The small size and battery-powered operation associated with LCD-equipped apparatus dictate low component count and high efficiency for these circuits. Size constraints place severe limitations on circuit architecture and long battery life is usually a priority. Handheld portable computers offer an excellent example. The CCFL and its power supply can be responsible for almost 50% of the total battery drain.

The CCFL regulator drives an inductor that acts as a switch-mode current source for a current-driven Royer-class converter with efficiencies as high as 90%. The control loop forces the CCFL PWM to modulate the average inductor current to maintain constant current in the lamp. This constant current and the resulting lamp intensity is programmable. Lamp intensity is further controlled by modulating the current to the Royer converter at 150Hz to 500Hz.

Operation

The LTC1697 is a fixed frequency, current mode regulator. Such a switcher controls switch duty cycle directly by switch current rather than by output voltage. Referring to the block diagram for the LTC1697, the NMOS switch turns ON at the start of each oscillator cycle. The NMOS switch turns back OFF when switch current reaches a predetermined level.

Current Sensing

Lossless current sensing converts the peak current signal to a voltage which is summed with the internal slope compensation. This summed signal is compared to V_C to provide a peak current control command for the PWM.

Current Limit

The current limit amplifier will shut the NMOS switch off once the current exceeds the current limit threshold. The current amplifier delay to the output is typically 50ns.

Synchronous Rectifier

The LTC1697 operates as a synchronous converter. When the NMOS switch turns OFF as mentioned above, the PMOS switch turns ON. This gives a low resistance current path for the inductor current back to V_{IN} .

Dimming PWM

An on-chip PWM dimming circuit enables and disables the current mode regulator for each dimming cycle. It also disconnects the feedback network from the compensation node (V_C) to reduce slew time at the next enable time. The oscillator for the dimming PWM produces a triangle wave whose frequency is determined by an external capacitor on the C_{DIM} pin. The dimming PWM frequency is equal to $5\text{Hz}/C_{DIM}(\mu\text{F})$ with its duty cycle set by the voltage on the

APPLICATIONS INFORMATION

V_{DIM} pin where DC = 0% at $V_{DIM} = 1V$ and DC = 100% at $V_{DIM} = 2V$. If desired, the internal dimming PWM can be overridden by grounding the C_{DIM} pin and applying the input PWM signal to the V_{DIM} pin. This external PWM signal should be in the range of 150Hz to 500Hz.

Lamp Feedback

In a typical application, the LAMP pin is connected to the low voltage side of the lamp. The lamp pin is internally connected to ground by a $\sim 50\Omega$ resistor. This resistor will limit the voltage on the LAMP pin to $\pm 0.35V$ for a $5mA_{RMS}$ lamp current. The lamp feedback circuit removes a current from V_C approximating 1/40 of the absolute value of the current through the 50Ω resistor.

Current Programming Input (R_{PROG})

The I_{LAMP} current is set with an external resistor connected between this pin and ground. $I_{LAMP} = 32V/R_{PROG}$.

V_C Compensation

The V_C node is the point where the lamp feedback current, the programming current, and the control for the switching controller meet. A single capacitor must be connected from the V_C pin to ground to compensate the feedback loop. Careful consideration should be given to the value of capacitance used. A large value ($1\mu F$) will give excellent stability at high lamp currents but will result in degraded line regulation. On the other hand, a small value ($10nF$) will result in overshoot and poor load regulation. The value chosen will depend on the maximum load current and dimming range. After these parameters are decided upon, the value of the V_C capacitor should be increased until the

line regulation becomes unacceptable. A typical value for the V_C capacitor is $0.1\mu F$. For further information on compensation please refer to Application Note 65 or consult the factory.

OV_{SEN} Operation

The OV_{SEN} pin can be used to protect the high voltage transformer from an overvoltage condition that can occur when the lamp is open or not present. Connect this pin through a resistor to the emitters of the drive transistors of the Royer oscillator. The voltage at the OV_{SEN} pin is specified by $V_{OV_{SEN}}$. The duty cycle of the LTC1697 SW pin will be 0% when the current flowing out of the OV_{SEN} pin reaches $I_{OV_{SEN}}$ (protect). See the manufacturers transformer specifications for transformer voltage ratings.

Thermal Shutdown

This IC includes overtemperature protection that is intended to protect the device during momentary overload conditions. Junction temperature will exceed $125^\circ C$ when overtemperature protection is active. Continuous operation above the specified maximum operating junction temperature may result in device degradation or failure.

Shutdown Operation

There are two ways to place the LTC1697 in shutdown. The SHDN pin can be pulled below V_{SHDN-1} , or the V_{DIM} pin can be pulled below $V_{DIM(SD-1)}$ for more than approximately 50mS. For normal operation, both pins must be pulled high. The SHDN pin must be pulled above V_{SHDN-H} , and the V_{DIM} pin must be pulled above $V_{DIM(SD-H)}$.

PACKAGE DESCRIPTION

MS Package 10-Lead Plastic MSOP

(Reference LTC DWG # 05-08-1661)

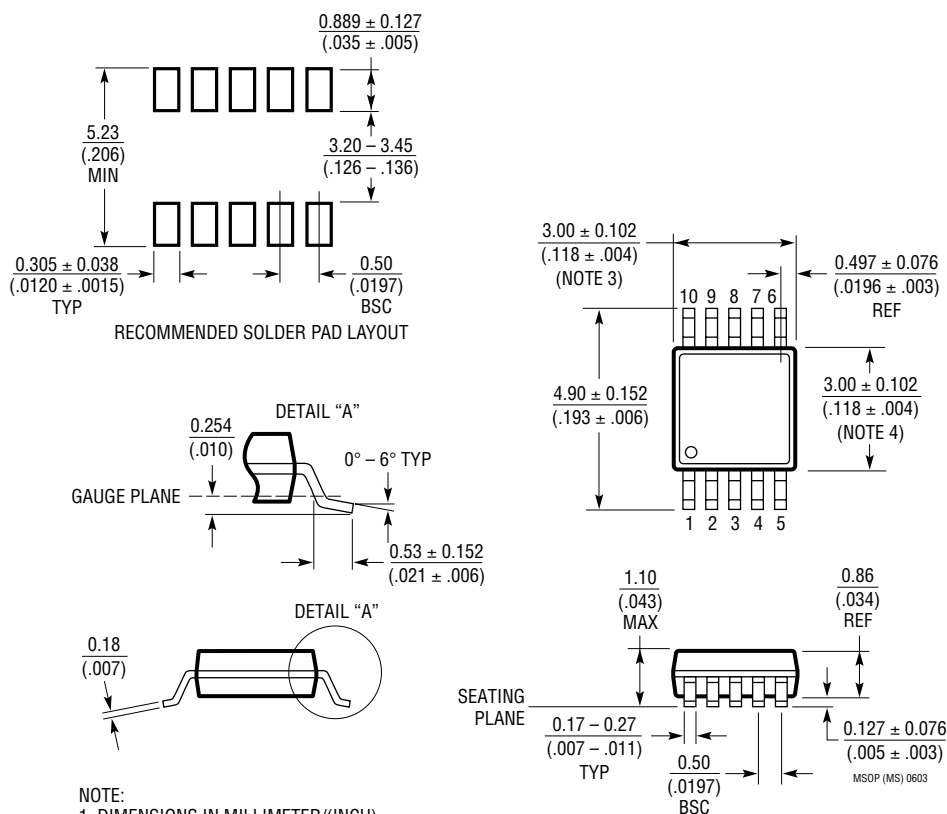

NOTE:

1. DIMENSIONS IN MILLIMETER/(INCH)
2. DRAWING NOT TO SCALE
3. DIMENSION DOES NOT INCLUDE MOLD FLASH, PROTRUSIONS OR GATE BURRS.
MOLD FLASH, PROTRUSIONS OR GATE BURRS SHALL NOT EXCEED 0.152mm (.006") PER SIDE
4. DIMENSION DOES NOT INCLUDE INTERLEAD FLASH OR PROTRUSIONS.
INTERLEAD FLASH OR PROTRUSIONS SHALL NOT EXCEED 0.152mm (.006") PER SIDE
5. LEAD COPLANARITY (BOTTOM OF LEADS AFTER FORMING) SHALL BE 0.102mm (.004") MAX

Looking for pricing, stock, or lifecycle information?

Click below to explore more details on WIN SOURCE:

 [View LTC1697EMS#TRPBF on WIN SOURCE](#)

 [Linear Technology](#) Information

Optimize Your Supply Chain with WIN SOURCE Solutions

-  Global Sourcing Solution
-  Obsolete Management
-  Cost Control Management
-  Shortage Management
-  Alternative Solution
-  Excess Inventory Management