



**THE DATASHEET OF
LTC3414MPFE#PBF**



4A, 4MHz, Monolithic Synchronous Step-Down Regulator

FEATURES

- **High Efficiency: Up to 95%**
- **4A Output Current**
- **Low Quiescent Current: 64 μ A**
- **Low $R_{DS(ON)}$ Internal Switch: 67m Ω**
- Programmable Frequency: 300KHz to 4MHz
- 2.25V to 5.5V Input Voltage Range
- $\pm 2\%$ Output Voltage Accuracy
- 0.8V Reference Allows Low Output Voltage
- Selectable Forced Continuous/Burst Mode[®] Operation with Adjustable Burst Clamp
- Synchronizable Switching Frequency
- Low Dropout Operation: 100% Duty Cycle
- Power Good Output Voltage Monitor
- Overtemperature Protected
- Available in 20-Lead Exposed TSSOP Package

APPLICATIONS

- Point-of-Load Regulation
- Notebook Computers
- Portable Instruments
- Distributed Power Systems

DESCRIPTION

The LTC[®]3414 is a high efficiency monolithic synchronous, step-down DC/DC converter utilizing a constant frequency, current mode architecture. It operates from an input voltage range of 2.25V to 5.5V and provides a regulated output voltage from 0.8V to 5V while delivering up to 4A of output current. The internal synchronous power switch with 67m Ω on-resistance increases efficiency and eliminates the need for an external Schottky diode. Switching frequency is set by an external resistor or can be synchronized to an external clock. 100% duty cycle provides low dropout operation extending battery life in portable systems. OPTI-LOOP[®] compensation allows the transient response to be optimized over a wide range of loads and output capacitors.

The LTC3414 can be configured for either Burst Mode operation or forced continuous operation. Forced continuous operation reduces noise and RF interference while Burst Mode operation provides high efficiency by reducing gate charge losses at light loads. In Burst Mode operation, external control of the burst clamp level allows the output voltage ripple to be adjusted according to the requirements of the application.

LT, LTC and LT are registered trademarks of Linear Technology Corporation. Burst Mode and OPTI-LOOP are registered trademarks of Linear Technology Corporation. All other trademarks are the property of their respective owners. Protected by U.S. Patents, including 5481178, 6580258, 6304066, 6127815, 6498466, 6611131, 6724174

TYPICAL APPLICATION

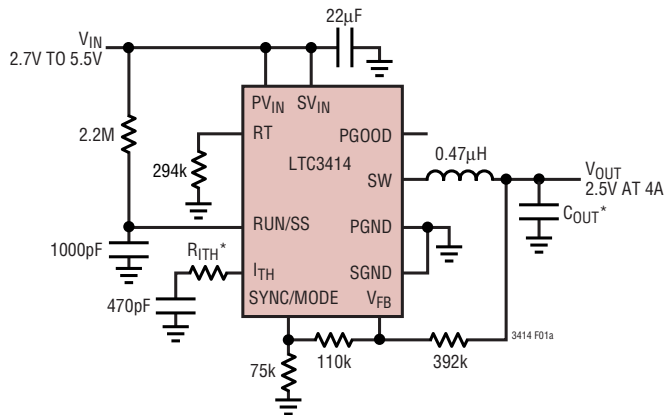

*Burst Mode OPERATION: $C_{OUT} = 470\mu\text{F}$ SANYO POSCAP 4TPB470M, $R_{ITH} = 20\text{k}$
 FORCED CONTINUOUS: $C_{OUT} = (2) 100\mu\text{F}$ TDKC4532X5R0J107M, $R_{ITH} = 12.1\text{k}$

Figure 1. 2.5V/4A Step-Down Regulator

LTC3414 Efficiency Curve

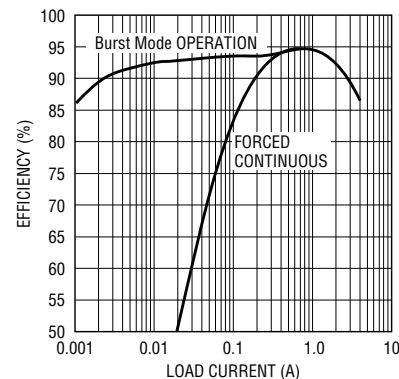

3414 F01b

ABSOLUTE MAXIMUM RATINGS

(Note 1)

Input Supply Voltage	-0.3V to 6V
I_{TH} , RUN/SS, V_{FB} , SYNC/MODE Voltages	-0.3 to V_{IN}
SW Voltages	-0.3V to ($V_{IN} + 0.3V$)
Peak SW Sink and Source Current	9.5A
Operating Temperature Range (Note 2)	
E, I Grades	-40°C to 85°C
MP Grade	-55°C to 125°C
Junction Temperature (Notes 5, 6)	125°C
Storage Temperature Range	-65°C to 150°C
Lead Temperature (Soldering, 10 sec)	300°C

PACKAGE/ORDER INFORMATION

<p>FE PACKAGE 20-LEAD PLASTIC TSSOP</p> <p>EXPOSED PAD (PIN 21), MUST BE SOLDERED TO PCB $T_{JMAX} = 125^{\circ}C$, $\theta_{JA} = 38^{\circ}C/W$, $\theta_{JC} = 10^{\circ}C/W$</p>	ORDER PART NUMBER
	LTC3414EFE LTC3414IFE LTC3414MPFE
Order Options Tape and Reel: Add #TR Lead Free: Add #PBF Lead Free Tape and Reel: Add #TRPBF Lead Free Part Marking: http://www.linear.com/leadfree/	

ELECTRICAL CHARACTERISTICS

The ● denotes the specifications which apply over the full operating temperature range, otherwise specifications are at $T_A = 25^{\circ}C$. $V_{IN} = 3.3V$ unless otherwise specified.

SYMBOL	PARAMETER	CONDITIONS	MIN	TYP	MAX	UNITS
V_{IN}	Input Voltage Range		● 2.25		5.5	V
I_{FB}	Feedback Pin Input Current	(Note 3)			0.2	μA
V_{FB}	Regulated Feedback Voltage	E, I Grade (Note 3) MP Grade	● 0.784 ● 0.780	0.800 0.800	0.816 0.816	V
ΔV_{FB}	Reference Voltage Line Regulation	$V_{IN} = 2.7V$ to $5.5V$ (Note 3)	●	0.04	0.2	%V
$V_{LOADREG}$	Output Voltage Load Regulation	Measured in Servo Loop, $V_{ITH} = 0.36V$ Measured in Servo Loop, $V_{ITH} = 0.84V$	●	0.02 -0.02	0.2 -0.2	%
ΔV_{PGOOD}	Power Good Range			± 7.5	± 9	%
R_{PGOOD}	Power Good Resistance			120	200	Ω
I_Q	Input DC Bias Current	(Note 4)				
	Active Current	$V_{FB} = 0.75V$, $V_{ITH} = 1.2V$		250	330	μA
	Sleep	$V_{FB} = 1V$, $V_{ITH} = 0V$, $V_{SYNC/MODE} = 0V$		64	100	μA
	Shutdown	$V_{RUN} = 0V$		0.02	1	μA
f_{OSC}	Switching Frequency	$R_{OSC} = 294k$	0.88	1.00	1.12	MHz
	Switching Frequency Range		0.3		4	MHz
f_{SYNC}	SYNC Capture Range		0.3		4	MHz
R_{PFET}	$R_{DS(ON)}$ of P-Channel FET	$I_{SW} = 300mA$		67	100	m Ω
R_{NFET}	$R_{DS(ON)}$ of N-Channel FET	$I_{SW} = -300mA$		50	100	m Ω
I_{LIMIT}	Peak Current Limit		6	8		A
V_{UVLO}	Undervoltage Lockout Threshold		1.75	2.00	2.25	V
I_{LSW}	SW Leakage Current	$V_{RUN} = 0V$, $V_{IN} = 5.5V$		0.1	1.0	μA
V_{RUN}	RUN Threshold		0.5	0.65	0.8	V

Note 1: Stresses beyond those listed under Absolute Maximum Ratings may cause permanent damage to the device. Exposure to any Absolute Maximum Rating condition for extended periods may affect device reliability and lifetime.

Note 2: The LTC3414E is guaranteed to meet performance specifications from 0°C to 85°C. Specifications over the -40°C to 85°C operating temperature range are assured by design, characterization and correlation with statistical process controls. The LTC3414I is guaranteed over the full -40°C to 85°C operating temperature range. The LTC3414MP is guaranteed over the full -55°C to 125°C operating temperature range.

Note 3: The LTC3414 is tested in a feedback loop that adjusts V_{FB} to

achieve a specified error amplifier output voltage (I_{TH}).

Note 4: Dynamic supply current is higher due to the internal gate charge being delivered at the switching frequency.

Note 5: T_J is calculated from the ambient temperature T_A and power dissipation P_D as follows: $T_J = T_A + (P_D)(38^{\circ}C/W)$

Note 6: This IC includes overtemperature protection that is intended to protect the device during momentary overload conditions. Junction temperature will exceed 125°C when overtemperature protection is active. Continuous operation above the specified maximum operating junction temperature may impair device reliability.

TYPICAL PERFORMANCE CHARACTERISTICS

V_{REF} vs Temperature, V_{IN} = 3.3V

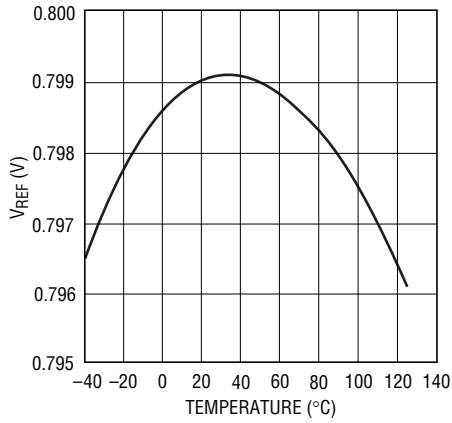

3414 G01

Switch On-Resistance vs Input Voltage

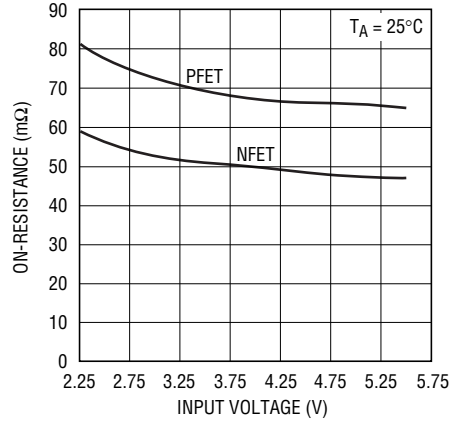

3414 G02

Switch On-Resistance vs Temperature, V_{IN} = 3.3V

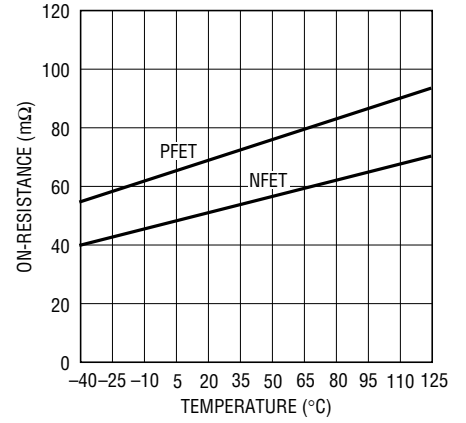

3414 G03

Switch Leakage vs Input Voltage

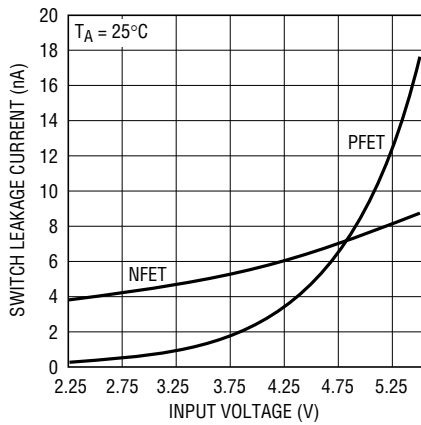

3414 G04

Frequency vs R_{OSC}

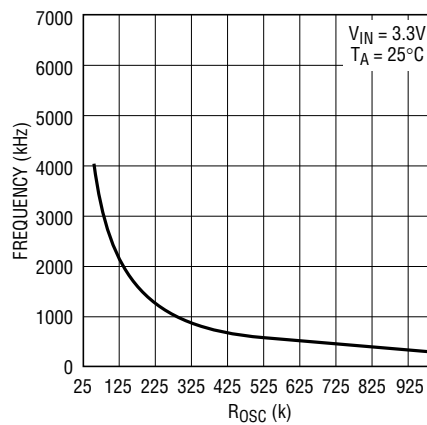

3414 G05

Frequency vs Input Voltage

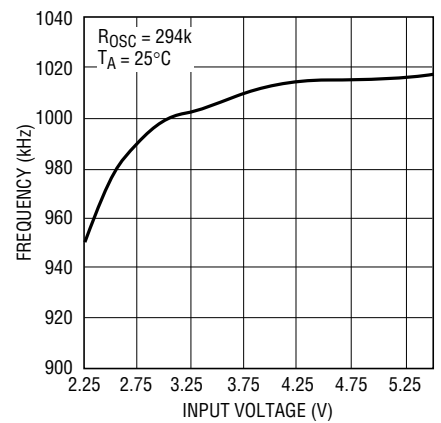

3414 G06

Frequency vs Temperature

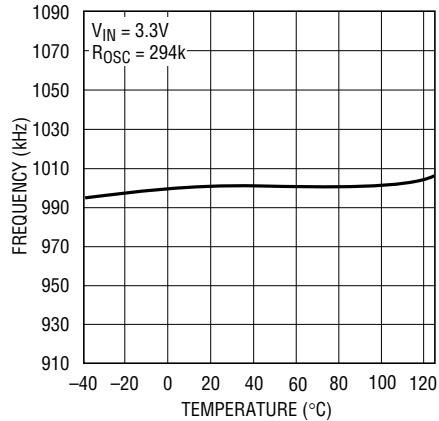

3414 G07

DC Supply Current vs Input Voltage

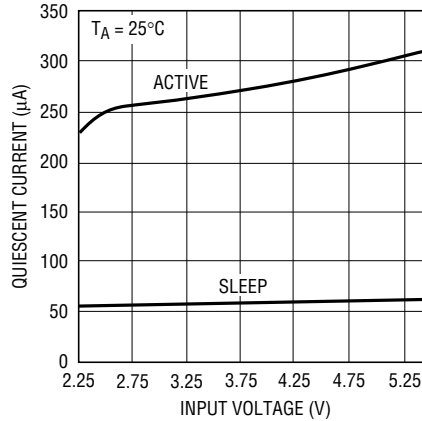

3414 G08

Minimum Peak Inductor Current vs Burst Clamp Voltage

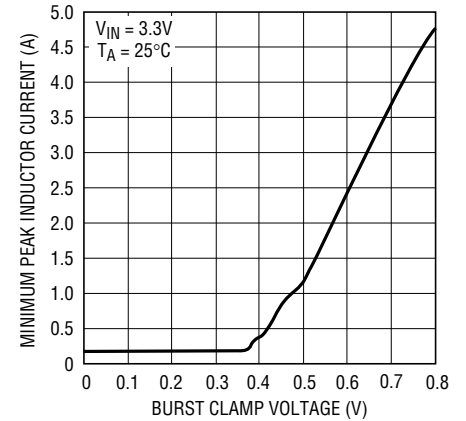

3414 G09

TYPICAL PERFORMANCE CHARACTERISTICS

Efficiency vs Load Current, Burst Mode Operation

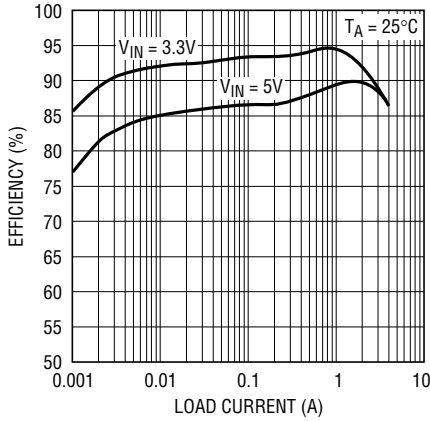

3414 G10

Efficiency vs Load Current, Forced Continuous

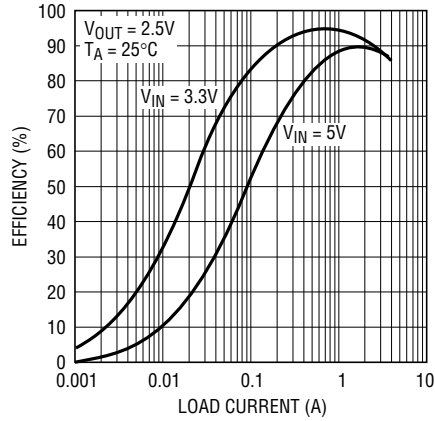

3414 G11

Efficiency vs Load Current

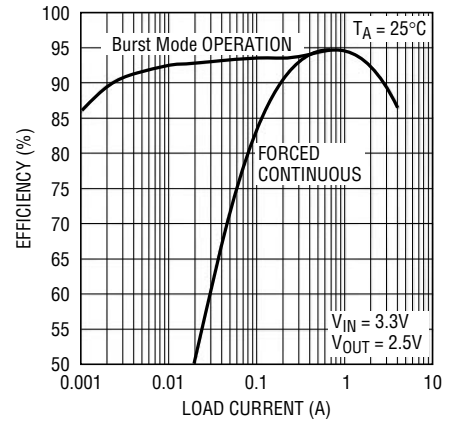

3414 G12

Efficiency vs Input Voltage

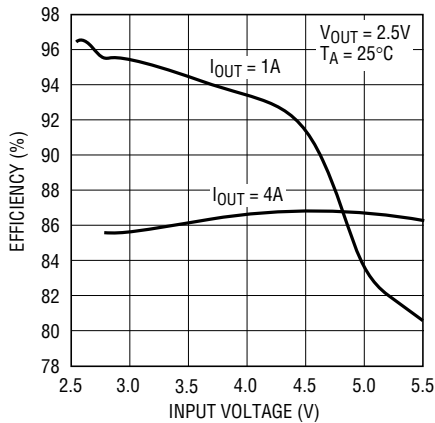

3414 G13

Efficiency vs Frequency

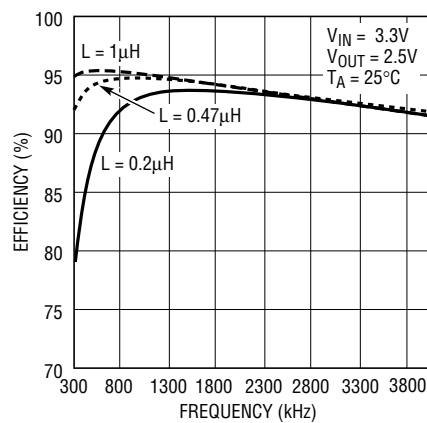

3414 G14

Load Regulation

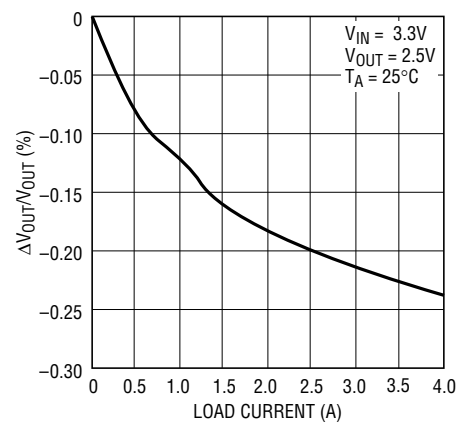

3414 G15

Burst Mode Operation

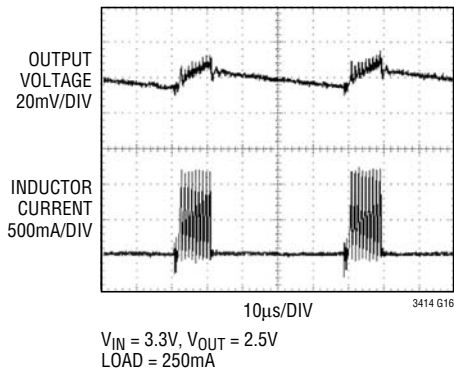

3414 G16

Load Step Transient Forced Continuous

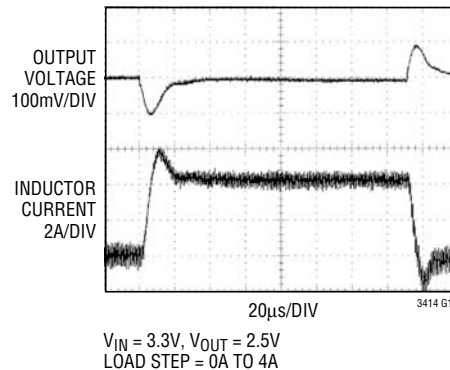

3414 G17

TYPICAL PERFORMANCE CHARACTERISTICS

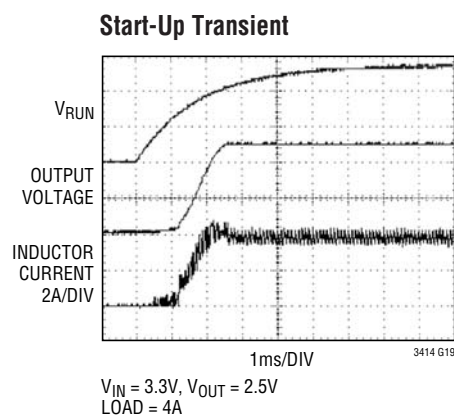
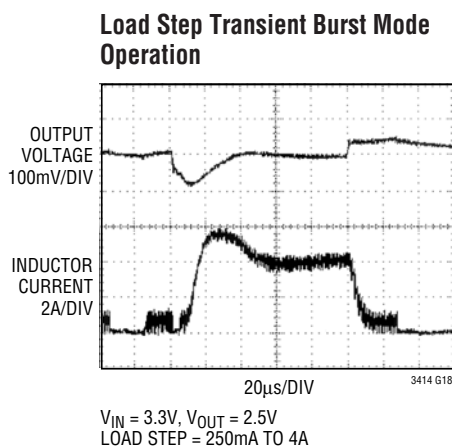

PIN FUNCTIONS

PGND (Pins 1, 10, 11, 20): Power Ground. Connect this pin closely to the (–) terminal of C_{IN} and C_{OUT} .

RT (Pin 2): Oscillator Resistor Input. Connecting a resistor to ground from this pin sets the switching frequency.

SYNC/MODE (Pin 3): Mode Select and External Clock Synchronization Input. To select Forced Continuous, tie to SV_{IN} . Connecting this pin to a voltage between 0V and 1V selects Burst Mode operation with the burst clamp set to the pin voltage.

RUN/SS (Pin 4): Run Control and Soft-Start Input. Forcing this pin below 0.5V shuts down the LTC3414. In shutdown all functions are disabled. Less than 1µA of supply current is consumed. A capacitor to ground from this pin sets the ramp time to full output current.

SGND (Pin 5): Signal Ground. All small signal components and compensation components should connect to this ground, which in turn connects to PGND at one point.

NC (Pin 6): Open. No internal connection.

PV_{IN} (Pins 7, 14): Power Input Supply. Decouple this pin to PGND with a capacitor.

SW (Pins 8, 9, 12, 13): Switch Node Connection to Inductor. This pin connects to the drains of the internal main and synchronous power MOSFET switches.

NC (Pin 15): Open. No internal connection.

SV_{IN} (Pin 16): Signal Input Supply. Decouple this pin to SGND with a capacitor.

PGOOD (Pin 17): Power Good Output. Open drain logic output that is pulled to ground when the output voltage is not within $\pm 7.5\%$ of regulation point.

I_{TH} (Pin 18): Error Amplifier Compensation Point. The current comparator threshold increases with this control voltage. Nominal voltage range for this pin is from 0.2V to 1.4V with 0.4V corresponding to the zero-sense voltage (zero current).

V_{FB} (Pin 19): Feedback Pin. Receives the feedback voltage from a resistive divider connected across the output.

Exposed Pad (Pin 21): Should be connected to SGND and soldered to the PCB.

BLOCK DIAGRAM

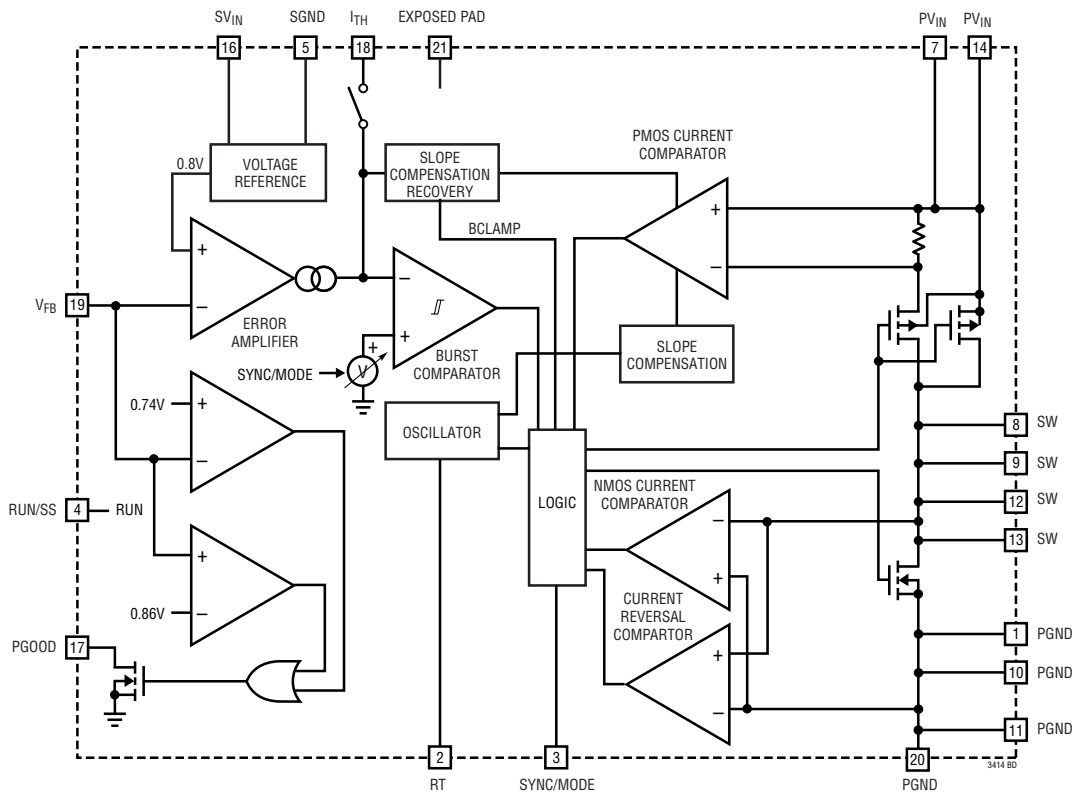

OPERATION

Main Control Loop

The LTC3414 is a monolithic, constant-frequency, current-mode step-down DC/DC converter. During normal operation, the internal top power switch (P-channel MOSFET) is turned on at the beginning of each clock cycle. Current in the inductor increases until the current comparator trips and turns off the top power MOSFET. The peak inductor current at which the current comparator shuts off the top power switch is controlled by the voltage on the I_{TH} pin. The error amplifier adjusts the voltage on the I_{TH} pin by comparing the feedback signal from a resistor divider on the V_{FB} pin with an internal 0.8V reference. When the load current increases, it causes a reduction in the feedback voltage relative to the reference. The error amplifier raises the I_{TH} voltage until the average inductor current matches the new load current. When the top power MOSFET shuts off, the synchronous power switch (N-channel MOSFET) turns on until either the bottom current limit is reached or the beginning of the next

clock cycle. The bottom current limit is set at $-5A$ for forced continuous mode and $0A$ for Burst Mode operation.

The operating frequency is externally set by an external resistor connected between the RT pin and ground. The practical switching frequency can range from 300kHz to 4MHz.

Overvoltage and undervoltage comparators will pull the PGOOD output low if the output voltage comes out of regulation by $\pm 7.5\%$. In an overvoltage condition, the top power MOSFET is turned off and the bottom power MOSFET is switched on until either the overvoltage condition clears or the bottom MOSFET's current limit is reached.

Forced Continuous Mode

Connecting the SYNC/MODE pin to SV_{IN} will disable Burst Mode operation and force continuous current operation. At light loads, forced continuous mode operation is less efficient than Burst Mode operation, but may be desirable in some applications where it is necessary to keep switch-

OPERATION

ing harmonics out of a signal band. The output voltage ripple is minimized in this mode.

Burst Mode Operation

Connecting the SYNC/MODE pin to a voltage in the range of 0V to 1V enables Burst Mode operation. In Burst Mode operation, the internal power MOSFETs operate intermittently at light loads. This increases efficiency by minimizing switching losses. During Burst Mode operation, the minimum peak inductor current is externally set by the voltage on the SYNC/MODE pin and the voltage on the I_{TH} pin is monitored by the burst comparator to determine when sleep mode is enabled and disabled. When the average inductor current is greater than the load current, the voltage on the I_{TH} pin drops. As the I_{TH} voltage falls below 150mV, the burst comparator trips and enables sleep mode. During sleep mode, the top power MOSFET is held off and the I_{TH} pin is disconnected from the output of the error amplifier. The majority of the internal circuitry is also turned off to reduce the quiescent current to 64 μ A while the load current is solely supplied by the output capacitor. When the output voltage drops, the I_{TH} pin is reconnected to the output of the error amplifier and the top power MOSFET along with all the internal circuitry is switched back on. This process repeats at a rate that is dependent on the load demand.

Pulse Skipping operation is implemented by connecting the SYNC/MODE pin to ground. This forces the burst clamp level to be at 0V. As the load current decreases, the peak inductor current will be determined by the voltage on the I_{TH} pin until the I_{TH} voltage drops below 400mV. At this point, the peak inductor current is determined by the minimum on-time of the current comparator. If the load demand is less than the average of the minimum on-time inductor current, switching cycles will be skipped to keep the output voltage in regulation.

Frequency Synchronization

The internal oscillator of the LTC3414 can be synchronized to an external clock connected to the SYNC/MODE pin. The frequency of the external clock can be in the range of 300kHz to 4MHz. For this application, the oscillator timing resistor should be chosen to correspond to a frequency that is 25% lower than the synchronization frequency.

During synchronization, the burst clamp is set to 0V, and each switching cycle begins at the falling edge of the clock signal.

Dropout Operation

When the input supply voltage decreases toward the output voltage, the duty cycle increases toward the maximum on-time. Further reduction of the supply voltage forces the main switch to remain on for more than one cycle eventually reaching 100% duty cycle. The output voltage will then be determined by the input voltage minus the voltage drop across the internal P-channel MOSFET and the inductor.

Low Supply Operation

The LTC3414 is designed to operate down to an input supply voltage of 2.25V. One important consideration at low input supply voltages is that the $R_{DS(ON)}$ of the P-channel and N-channel power switches increases. The user should calculate the power dissipation when the LTC3414 is used at 100% duty cycle with low input voltages to ensure that thermal limits are not exceeded.

Slope Compensation and Inductor Peak Current

Slope compensation provides stability in constant frequency architectures by preventing subharmonic oscillations at duty cycles greater than 50%. It is accomplished internally by adding a compensating ramp to the inductor current signal at duty cycles in excess of 40%. Normally, the maximum inductor peak current is reduced when slope compensation is added. In the LTC3414, however, slope compensation recovery is implemented to keep the maximum inductor peak current constant throughout the range of duty cycles. This keeps the maximum output current relatively constant regardless of duty cycle.

Short-Circuit Protection

When the output is shorted to ground, the inductor current decays very slowly during a single switching cycle. To prevent current runaway from occurring, a secondary current limit is imposed on the inductor current. If the inductor valley current increases larger than 7.8A, the top power MOSFET will be held off and switching cycles will be skipped until the inductor current is reduced.

APPLICATIONS INFORMATION

The basic LTC3414 application circuit is shown in Figure 1. External component selection is determined by the maximum load current and begins with the selection of the operating frequency and inductor value followed by C_{IN} and C_{OUT} .

Operating Frequency

Selection of the operating frequency is a tradeoff between efficiency and component size. High frequency operation allows the use of smaller inductor and capacitor values. Operation at lower frequencies improves efficiency by reducing internal gate charge losses but requires larger inductance values and/or capacitance to maintain low output ripple voltage.

The operating frequency of the LTC3414 is determined by an external resistor that is connected between pin R_T and ground. The value of the resistor sets the ramp current that is used to charge and discharge an internal timing capacitor within the oscillator and can be calculated by using the following equation:

$$R_{OSC} = \frac{3.08 \cdot 10^{11}}{f} (\Omega) - 10k\Omega$$

Although frequencies as high as 4MHz are possible, the minimum on-time of the LTC3414 imposes a minimum limit on the operating duty cycle. The minimum on-time is typically 110ns; therefore, the minimum duty cycle is equal to $100 \cdot 110ns \cdot f(Hz)$.

Inductor Selection

For a given input and output voltage, the inductor value and operating frequency determine the ripple current. The ripple current ΔI_L increases with higher V_{IN} or V_{OUT} and decreases with higher inductance.

$$\Delta I_L = \left(\frac{V_{OUT}}{f \cdot L} \right) \left(1 - \frac{V_{OUT}}{V_{IN}} \right)$$

Having a lower ripple current reduces the core losses in the inductor, the ESR losses in the output capacitors, and the output voltage ripple. Highest efficiency operation is achieved at low frequency with small ripple current. This, however, requires a large inductor.

A reasonable starting point for selecting the ripple current is $\Delta I_L = 0.4(I_{MAX})$. The largest ripple current occurs at the highest V_{IN} . To guarantee that the ripple current stays below a specified maximum, the inductor value should be chosen according to the following equation:

$$L = \left(\frac{V_{OUT}}{f \Delta I_L (MAX)} \right) \left(1 - \frac{V_{OUT}}{V_{IN} (MAX)} \right)$$

The inductor value will also have an effect on Burst Mode operation. The transition to low current operation begins when the peak inductor current falls below a level set by the burst clamp. Lower inductor values result in higher ripple current which causes this to occur at lower load currents. This causes a dip in efficiency in the upper range of low current operation. In Burst Mode operation, lower inductance values will cause the burst frequency to increase.

Inductor Core Selection

Once the value for L is known, the type of inductor must be selected. Actual core loss is independent of core size for a fixed inductor value, but it is very dependent on the inductance selected. As the inductance increases, core losses decrease. Unfortunately, increased inductance requires more turns of wire and therefore copper losses will increase.

Ferrite designs have very low core losses and are preferred at high switching frequencies, so design goals can concentrate on copper loss and preventing saturation. Ferrite core material saturates "hard," which means that inductance collapses abruptly when the peak design current is exceeded. This results in an abrupt increase in inductor ripple current and consequent output voltage ripple. Do not allow the core to saturate!

Different core materials and shapes will change the size/current and price/current relationship of an inductor. Toroid or shielded pot cores in ferrite or permalloy materials are small and don't radiate much energy, but generally cost more than powdered iron core inductors with similar characteristics. The choice of which style inductor to use mainly depends on the price versus size requirements and any radiated field/EMI requirements. New designs for surface mount inductors are available from Coiltronics, Coilcraft, Toko, and Sumida.

APPLICATIONS INFORMATION

C_{IN} and C_{OUT} Selection

The input capacitance, C_{IN} , is needed to filter the trapezoidal wave current at the source of the top MOSFET. To prevent large voltage transients from occurring, a low ESR input capacitor sized for the maximum RMS current should be used. The maximum RMS current is given by:

$$I_{RMS} = I_{OUT(MAX)} \frac{V_{OUT}}{V_{IN}} \sqrt{\frac{V_{IN}}{V_{OUT}} - 1}$$

This formula has a maximum at $V_{IN} = 2V_{OUT}$, where $I_{RMS} = I_{OUT}/2$. This simple worst-case condition is commonly used for design because even significant deviations do not offer much relief. Note that ripple current ratings from capacitor manufacturers are often based on only 2000 hours of life which makes it advisable to further derate the capacitor, or choose a capacitor rated at a higher temperature than required. Several capacitors may also be paralleled to meet size or height requirements in the design. For low input voltage applications, sufficient bulk input capacitance is needed to minimize transient effects during output load changes.

The selection of C_{OUT} is determined by the effective series resistance (ESR) that is required to minimize voltage ripple and load step transients as well as the amount of bulk capacitance that is necessary to ensure that the control loop is stable. Loop stability can be checked by viewing the load transient response as described in a later section. The output ripple, ΔV_{OUT} , is determined by:

$$\Delta V_{OUT} \leq \Delta I_L \left(ESR + \frac{1}{8fC_{OUT}} \right)$$

The output ripple is highest at maximum input voltage since ΔI_L increases with input voltage. Multiple capacitors placed in parallel may be needed to meet the ESR and RMS current handling requirements. Dry tantalum, special polymer, aluminum electrolytic, and ceramic capacitors are all available in surface mount packages. Special polymer capacitors offer very low ESR but have lower capacitance density than other types. Tantalum capacitors have the highest capacitance density but it is important to only use types that have been surge tested for use in switching power supplies. Aluminum electrolytic capacitors have significantly higher ESR, but can be used in cost-sensitive

applications provided that consideration is given to ripple current ratings and long term reliability. Ceramic capacitors have excellent low ESR characteristics but can have a high voltage coefficient and audible piezoelectric effects. The high Q of ceramic capacitors with trace inductance can also lead to significant ringing.

Using Ceramic Input and Output Capacitors

Higher values, lower cost ceramic capacitors are now becoming available in smaller case sizes. Their high ripple current, high voltage rating and low ESR make them ideal for switching regulator applications. However, care must be taken when these capacitors are used at the input and output. When a ceramic capacitor is used at the input and the power is supplied by a wall adapter through long wires, a load step at the output can induce ringing at the input, V_{IN} . At best, this ringing can couple to the output and be mistaken as loop instability. At worst, a sudden inrush of current through the long wires can potentially cause a voltage spike at V_{IN} large enough to damage the part.

When choosing the input and output ceramic capacitors, choose the X5R or X7R dielectric formulations. These dielectrics have the best temperature and voltage characteristics of all the ceramics for a given value and size.

Output Voltage Programming

The output voltage is set by an external resistive divider according to the following equation:

$$V_{OUT} = 0.8V \left(1 + \frac{R2}{R1} \right)$$

The resistive divider allows pin V_{FB} to sense a fraction of the output voltage as shown in Figure 2.

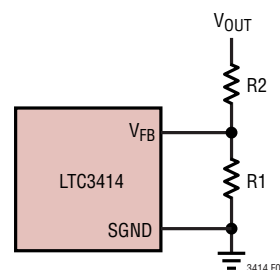

Figure 2. Setting the Output Voltage

APPLICATIONS INFORMATION

Burst Clamp Programming

If the voltage on the SYNC/MODE pin is less than V_{IN} by 1V, Burst Mode operation is enabled. During Burst Mode Operation, the voltage on the SYNC/MODE pin determines the burst clamp level, which sets the minimum peak inductor current, I_{BURST} , for each switching cycle according to the following equation:

$$I_{BURST} = \left(\frac{6.9A}{0.6V} \right) (V_{BURST} - 0.383V)$$

V_{BURST} is the voltage on the SYNC/MODE pin. I_{BURST} can only be programmed in the range of 0A to 7A. For values of V_{BURST} greater than 1V, I_{BURST} is set at 7A. For values of V_{BURST} less than 0.4V, I_{BURST} is set at 0A. As the output load current drops, the peak inductor currents decrease to keep the output voltage in regulation. When the output load current demands a peak inductor current that is less than I_{BURST} , the burst clamp will force the peak inductor current to remain equal to I_{BURST} regardless of further reductions in the load current. Since the average inductor current is greater than the output load current, the voltage on the I_{TH} pin will decrease. When the I_{TH} voltage drops to 150mV, sleep mode is enabled in which both power MOSFETs are shut off along with most of the circuitry to minimize power consumption. All circuitry is turned back on and the power MOSFETs begin switching again when the output voltage drops out of regulation. The value for I_{BURST} is determined by the desired amount of output voltage ripple. As the value of I_{BURST} increases, the sleep period between pulses and the output voltage ripple increase. The burst clamp voltage, V_{BURST} , can be set by a resistor divider from the V_{FB} pin to the SGND pin as shown in Figure 1.

Pulse skipping, which is a compromise between low output voltage ripple and efficiency, can be implemented by connecting pin SYNC/MODE to ground. This sets I_{BURST} to 0A. In this condition, the peak inductor current is limited by the minimum on-time of the current comparator. The lowest output voltage ripple is achieved while still operating discontinuously. During very light output loads, pulse skipping allows only a few switching cycles to be skipped while maintaining the output voltage in regulation.

Frequency Synchronization

The LTC3414's internal oscillator can be synchronized to an external clock signal. During synchronization, the top MOSFET turn-on is locked to the **falling** edge of the external frequency source. The synchronization frequency range is 300kHz to 4MHz. Synchronization only occurs if the external frequency is greater than the frequency set by the external resistor. Because slope compensation is generated by the oscillator's RC circuit, the external frequency should be set 25% higher than the frequency set by the external resistor to ensure that adequate slope compensation is present.

Soft-Start

The RUN/SS pin provides a means to shut down the LTC3414 as well as a timer for soft-start. Pulling the RUN/SS pin below 0.5V places the LTC3414 in a low quiescent current shutdown state ($I_Q < 1\mu A$).

The LTC3414 contains an internal soft-start clamp that gradually raises the clamp on I_{TH} after the RUN/SS pin is pulled above 2V. The full current range becomes available on I_{TH} after 1024 switching cycles. If a longer soft-start period is desired, the clamp on I_{TH} can be set externally with a resistor and capacitor on the RUN/SS pin as shown in Figure 1. The soft-start duration can be calculated by using the following formula:

$$t_{SS} = R_{SS} C_{SS} \ln \left(\frac{V_{IN}}{V_{IN} - 1.8V} \right) \text{ (SECONDS)}$$

Efficiency Considerations

The efficiency of a switching regulator is equal to the output power divided by the input power times 100%. It is often useful to analyze individual losses to determine what is limiting the efficiency and which change would produce the most improvement. Efficiency can be expressed as:

$$\text{Efficiency} = 100\% - (L1 + L2 + L3 + \dots)$$

where L1, L2, etc. are the individual losses as a percentage of input power.

Although all dissipative elements in the circuit produce losses, two main sources usually account for most of the losses: V_{IN} quiescent current and I^2R losses.

APPLICATIONS INFORMATION

The V_{IN} quiescent current loss dominates the efficiency loss at very low load currents whereas the I^2R loss dominates the efficiency loss at medium to high load currents. In a typical efficiency plot, the efficiency curve at very low load currents can be misleading since the actual power lost is of no consequence.

1. The V_{IN} quiescent current is due to two components: the DC bias current as given in the electrical characteristics and the internal main switch and synchronous switch gate charge currents. The gate charge current results from switching the gate capacitance of the internal power MOSFET switches. Each time the gate is switched from high to low to high again, a packet of charge dQ moves from V_{IN} to ground. The resulting dQ/dt is the current out of V_{IN} that is typically larger than the DC bias current. In continuous mode, $I_{GATECHG} = f(QT + QB)$ where QT and QB are the gate charges of the internal top and bottom switches. Both the DC bias and gate charge losses are proportional to V_{IN} ; thus, their effects will be more pronounced at higher supply voltages.

2. I^2R losses are calculated from the resistances of the internal switches, R_{SW} , and external inductor R_L . In continuous mode the average output current flowing through inductor L is “chopped” between the main switch and the synchronous switch. Thus, the series resistance looking into the SW pin is a function of both top and bottom MOSFET $R_{DS(ON)}$ and the duty cycle (DC) as follows:

$$R_{SW} = (R_{DS(ON)TOP})(DC) + (R_{DS(ON)BOT})(1 - DC)$$

The $R_{DS(ON)}$ for both the top and bottom MOSFETs can be obtained from the Typical Performance Characteristics curves. To obtain I^2R losses, simply add R_{SW} to R_L and multiply the result by the square of the average output current.

Other losses including C_{IN} and C_{OUT} ESR dissipative losses and inductor core losses generally account for less than 2% of the total loss.

Thermal Considerations

In most applications, the LTC3414 does not dissipate much heat due to its high efficiency.

However, in applications where the LTC3414 is running at high ambient temperature with low supply voltage and high duty cycles, such as in dropout, the heat dissipated may exceed the maximum junction temperature of the part. If the junction temperature reaches approximately 150°C, both power switches will be turned off and the SW node will become high impedance.

To avoid the LTC3414 from exceeding the maximum junction temperature, the user will need to do some thermal analysis. The goal of the thermal analysis is to determine whether the power dissipated exceeds the maximum junction temperature of the part. The temperature rise is given by:

$$t_r = (P_D)(\theta_{JA})$$

where P_D is the power dissipated by the regulator and θ_{JA} is the thermal resistance from the junction of the die to the ambient temperature. For the 20-lead exposed TSSOP package, the θ_{JA} is 38°C/W.

The junction temperature, T_J , is given by:

$$T_J = T_A + t_r$$

where T_A is the ambient temperature.

Note that at higher supply voltages, the junction temperature is lower due to reduced switch resistance ($R_{DS(ON)}$). To maximize the thermal performance of the LTC3414, the exposed pad should be soldered to a ground plane.

Checking Transient Response

The regulator loop response can be checked by looking at the load transient response. Switching regulators take several cycles to respond to a step in load current.

When a load step occurs, V_{OUT} immediately shifts by an amount equal to $\Delta I_{LOAD(ESR)}$, where ESR is the effective series resistance of C_{OUT} . ΔI_{LOAD} also begins to charge or discharge C_{OUT} generating a feedback error signal used by the regulator to return V_{OUT} to its steady-state value. During this recovery time, V_{OUT} can be monitored for overshoot or ringing that would indicate a stability problem. The I_{TH} pin external components and output capacitor shown in Figure 1 will provide adequate compensation for most applications.

APPLICATIONS INFORMATION

Design Example

As a design example, consider using the LTC3414 in an application with the following specifications:

$$V_{IN} = 2.7V \text{ to } 4.2V, V_{OUT} = 2.5V, I_{OUT(MAX)} = 4A, \\ I_{OUT(MIN)} = 100mA, f = 1MHz.$$

Because efficiency is important at both high and low load current, Burst Mode operation will be utilized.

First, calculate the timing resistor:

$$R_{OSC} = \frac{3.08 \cdot 10^{11}}{1 \cdot 10^6} - 10k = 298k$$

Use a standard value of 294k. Next, calculate the inductor value for about 40% ripple current at maximum V_{IN} :

$$L = \left(\frac{2.5V}{(1MHz)(1.6A)} \right) \left(1 - \frac{2.5V}{4.2V} \right) = 0.63\mu H$$

Using a 0.47 μ H inductor results in a maximum ripple current of:

$$\Delta I_L = \left(\frac{2.5V}{(1MHz)(0.47\mu H)} \right) \left(1 - \frac{2.5V}{4.2V} \right) = 2.15A$$

C_{OUT} will be selected based on the ESR that is required to satisfy the output voltage ripple requirement and the bulk capacitance needed for loop stability. For this design, a 22 μ F ceramic capacitor and a 470 μ F tantalum capacitor will be used.

C_{IN} should be sized for a maximum current rating of:

$$I_{RMS} = (4A) \left(\frac{2.5V}{4.2V} \right) \sqrt{\frac{4.2V}{2.5V} - 1} = 1.96A_{RMS}$$

Decoupling the PV_{IN} and SV_{IN} pins with two 22 μ F capacitors and a 330 μ F tantalum capacitor is adequate for most applications.

The burst clamp and output voltage can now be programmed by choosing the values of R1, R2, and R3. The voltage on pin MODE will be set to 0.49V by the resistor divider consisting of R2 and R3. A burst clamp voltage of 0.49V will set the minimum inductor current, I_{BURST} , as follows:

$$I_{BURST} = (V_{BURST} - 0.383V) \left(\frac{6.9A}{0.6V} \right) = 1.23A$$

If we set the sum of R2 and R3 to 200k, then the following equations can be solved:

$$R2 + R3 = 200k \\ 1 + \frac{R2}{R3} = \frac{0.8V}{0.49V}$$

The two equations shown above result in the following values for R2 and R3: R2 = 78.7k, R3 = 124k. The value of R1 can now be determined by solving the following equation.

$$1 + \frac{R1}{202.7k} = \frac{2.5V}{0.8V} \\ R1 = 432k$$

A value of 432k will be selected for R1. Figure 4 shows the complete schematic for this design example.

PC Board Layout Checklist

When laying out the printed circuit board, the following checklist should be used to ensure proper operation of the LTC3414. Check the following in your layout:

1. A ground plane is recommended. If a ground plane layer is not used, the signal and power grounds should be segregated with all small signal components returning to the SGND pin at one point which is then connected to the PGND pin close to the LTC3414.
2. Connect the (+) terminal of the input capacitor(s), C_{IN} , as close as possible to the PV_{IN} pin. This capacitor provides the AC current into the internal power MOSFETs.
3. Keep the switching node, SW, away from all sensitive small signal nodes.
4. Flood all unused areas on all layers with copper. Flooding with copper will reduce the temperature rise of power components. You can connect the copper areas to any DC net (PV_{IN} , SV_{IN} , V_{OUT} , PGND, SGND, or any other DC rail in your system).
5. Connect the V_{FB} pin directly to the feedback resistors. The resistor divider must be connected between V_{OUT} and SGND.

APPLICATIONS INFORMATION

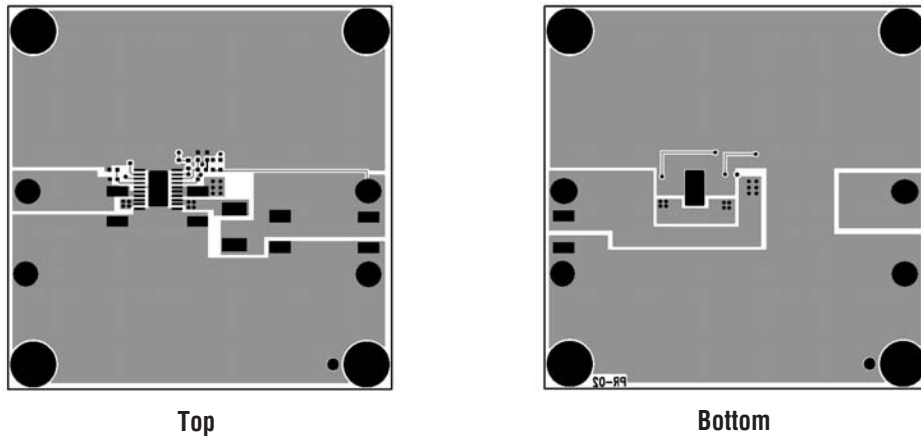
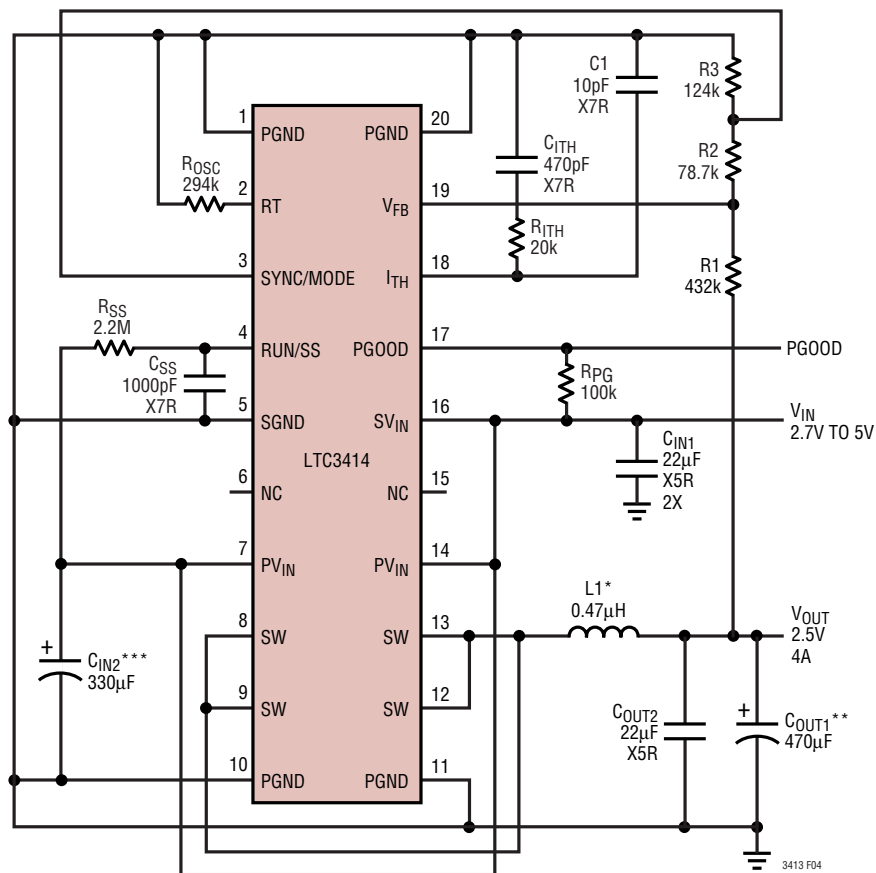

Figure 3. LTC3414 Layout Diagram



* VISHAY DALE IHLP-2525CZ-01
 ** SANYO POSCAP 4TPD470M
 *** SANYO POSCAP 6TPB330M

Figure 4. 2.5V, 4A Regulator at 1MHz, Burst Mode Operation

TYPICAL APPLICATIONS

3.3V, 4A Step-Down Regulator at 1MHz, Forced Continuous Mode

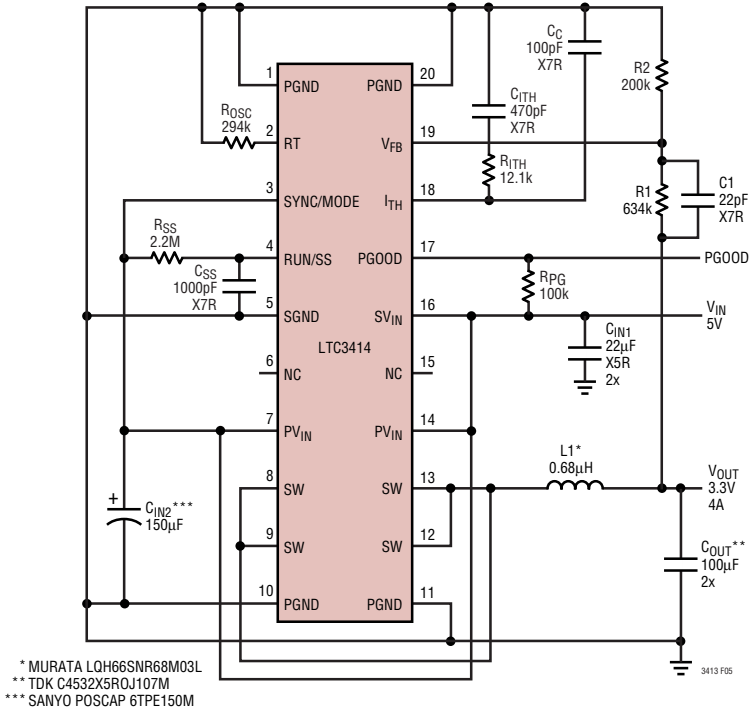

2.5V, 4A Step-Down Regulator at 1.25MHz, Synchronized to an External Clock

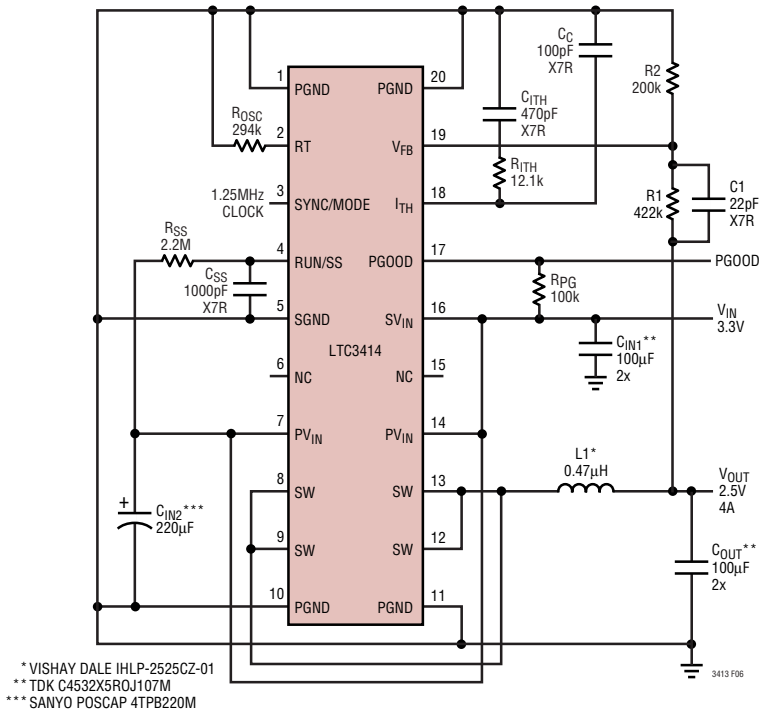

PACKAGE DESCRIPTION

FE Package
20-Lead Plastic TSSOP (4.4mm)
 (Reference LTC DWG # 05-08-1663)

Exposed Pad Variation CA

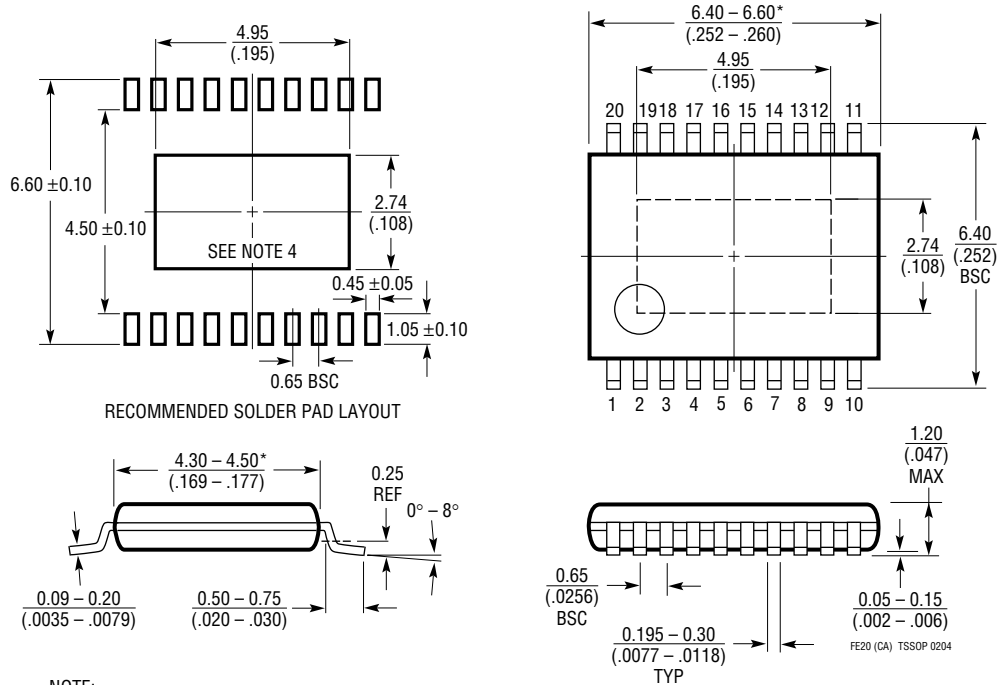

- NOTE:
1. CONTROLLING DIMENSION: MILLIMETERS
 2. DIMENSIONS ARE IN $\frac{\text{MILLIMETERS}}{\text{(INCHES)}}$
 3. DRAWING NOT TO SCALE
 4. RECOMMENDED MINIMUM PCB METAL SIZE FOR EXPOSED PAD ATTACHMENT
- *DIMENSIONS DO NOT INCLUDE MOLD FLASH. MOLD FLASH SHALL NOT EXCEED 0.150mm (.006") PER SIDE

TYPICAL APPLICATION

1.5V, 4A Step-Down Regulator at 1MHz, Burst Mode

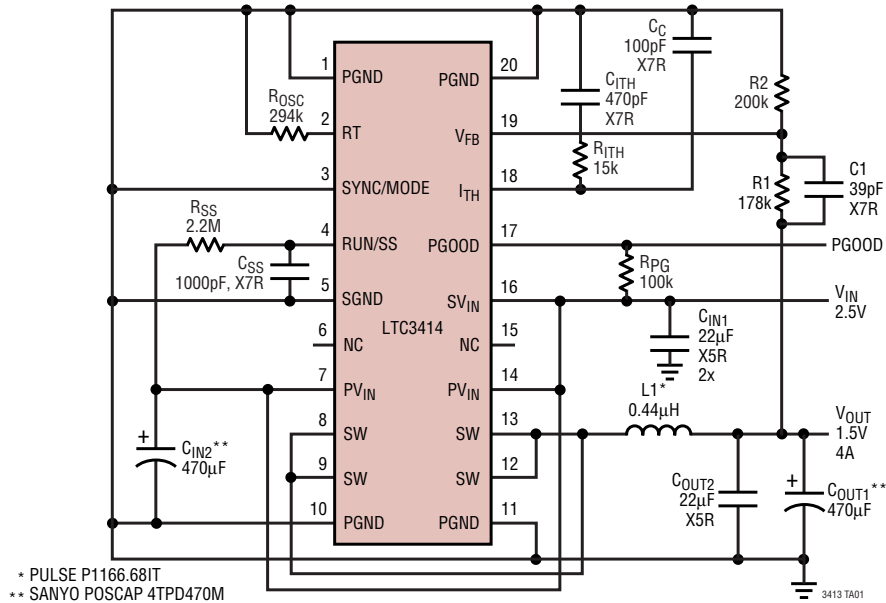

RELATED PARTS

PART NUMBER	DESCRIPTION	COMMENTS
LT1616	500mA (I _{OUT}), 1.4MHz, High Efficiency Step-Down DC/DC Converter	90% Efficiency, V _{IN} : 3.6V to 25V, V _{OUT} : 1.25V, I _Q : 1.9mA, I _{SD} : <1μA, ThinSOT Package
LT1676	450mA (I _{OUT}), 100kHz, High Efficiency Step-Down DC/DC Converter	90% Efficiency, V _{IN} : 7.4V to 60V, V _{OUT} : 1.24V, I _Q : 3.2mA, I _{SD} : 2.5μA, S8 Package
LT1765	25V, 2.75A (I _{OUT}), 1.25MHz, High Efficiency Step-Down DC/DC Converter	90% Efficiency, V _{IN} : 3V to 25V, V _{OUT} : 1.2V, I _Q : 1mA, I _{SD} : 15μA, S8, TSSOP16E Packages
LTC1879	1.20A (I _{OUT}), 550kHz, Synchronous Step-Down DC/DC Converter	95% Efficiency, V _{IN} : 2.7V to 10V, V _{OUT} : 0.8V, I _Q : 15μA, I _{SD} : <1μA, TSSOP16 Package
LTC3405/LTC3405A	300mA (I _{OUT}), 1.5MHz, Synchronous Step-Down DC/DC Converter	95% Efficiency, V _{IN} : 2.75V to 6V, V _{OUT} : 0.8V, I _Q : 20μA, I _{SD} : <1μA, ThinSOT Package
LTC3406/LTC3406B	600mA (I _{OUT}), 1.5MHz, Synchronous Step-Down DC/DC Converter	95% Efficiency, V _{IN} : 2.5V to 5.5V, V _{OUT} : 0.6V, I _Q : 20μA, I _{SD} : <1μA, ThinSOT Package
LTC3407	Dual 600mA (I _{OUT}), 1.5MHz, Synchronous Step-Down DC/DC Converter	95% Efficiency, V _{IN} : 2.5V to 5.5V, V _{OUT} : 0.6V, I _Q : 40μA, I _{SD} : <1μA, MS Package
LTC3411	1.25A (I _{OUT}), 4MHz, Synchronous Step-Down DC/DC Converter	95% Efficiency, V _{IN} : 2.5V to 5.5V, V _{OUT} : 0.8V, I _Q : 60μA, I _{SD} : <1μA, MS Package
LTC3412	2.5A (I _{OUT}), 4MHz, Synchronous Step-Down DC/DC Converter	95% Efficiency, V _{IN} : 2.5V to 5.5V, V _{OUT} : 0.8V, I _Q : 60μA, I _{SD} : <1μA, TSSOP16E Package
LTC3413	3A (I _{OUT} Sink/source), 2MHz, Monolithic Synchronous Regulator for DDR/QDR Memory Termination	90% Efficiency, V _{IN} : 2.25V to 5.5V, V _{OUT} : V _{REF} /2, I _Q : 280μA, I _{SD} : <1μA, TSSOP16E Package
LTC3430	60V, 2.75A (I _{OUT}), 200kHz, High Efficiency Step-Down DC/DC Converter	90% Efficiency, V _{IN} : 5.5V to 60V, V _{OUT} : 1.2V, I _Q : 2.5mA, I _{SD} : 25μA, TSSOP16E Package
LTC3440/LTC3441	600mA/1A (I _{OUT}), 2MHz/1MHz, Synchronous Buck-Boost DC/DC Converter	95% Efficiency, V _{IN} : 2.5V to 5.5V, V _{OUT} : 2.5V, I _Q : 25μA/50μA, I _{SD} : <1μA, MS Package

3414fb

Looking for pricing, stock, or lifecycle information?

Click below to explore more details on WIN SOURCE:

 [View LTC3414MPFE#PBF on WIN SOURCE](#)

 [Linear Technology](#) Information

Optimize Your Supply Chain with WIN SOURCE Solutions

-  Global Sourcing Solution
-  Obsolete Management
-  Cost Control Management
-  Shortage Management
-  Alternative Solution
-  Excess Inventory Management