



**THE DATASHEET OF
LTC3609IWKG#PBF**



32V, 6A Monolithic Synchronous Step-Down DC/DC Converter

FEATURES

- 6A Output Current
- Wide V_{IN} Range = 4V to 32V (36V Maximum)
- Internal N-Channel MOSFETs
- True Current Mode Control
- Optimized for High Step-Down Ratios
- $t_{ON(MIN)} \leq 100ns$
- Extremely Fast Transient Response
- Stable with Ceramic C_{OUT}
- $\pm 1\%$ 0.6V Voltage Reference
- Power Good Output Voltage Monitor
- Adjustable On-Time/Switching Frequency
- Adjustable Current Limit
- Programmable Soft-Start
- Output Overvoltage Protection
- Optional Short-Circuit Shutdown Timer
- Low Shutdown I_Q : 15 μ A
- Available in a 7mm \times 8mm 52-Pin QFN Package

APPLICATIONS

- Point of Load Regulation
- Distributed Power Systems

 , LT, LTC, LTM, Linear Technology and the Linear logo are registered trademarks of Linear Technology Corporation. All other trademarks are the property of their respective owners. Protected by U.S. Patents, including 5481178, 6100678, 6580258, 5847554, 6304066.

DESCRIPTION

The LTC[®]3609 is a high efficiency, monolithic synchronous step-down DC/DC converter that can deliver up to 6A output current from a 4V to 32V (36V maximum) input supply. It uses a valley current control architecture to deliver very low duty cycle operation at high frequency with excellent transient response. The operating frequency is selected by an external resistor and is compensated for variations in V_{IN} and V_{OUT} .

The LTC3609 can be configured for discontinuous or forced continuous operation at light load. Forced continuous operation reduces noise and RF interference while discontinuous mode provides high efficiency by reducing switching losses at light loads.

Fault protection is provided by internal foldback current limiting, an output overvoltage comparator and an optional short-circuit shutdown timer. Soft-start capability for supply sequencing is accomplished using an external timing capacitor. The regulator current limit is user programmable. A power good output voltage monitor indicates when the output is in regulation. The LTC3609 is available in a compact 7mm \times 8mm QFN package.

TYPICAL APPLICATION

High Efficiency Step-Down Converter

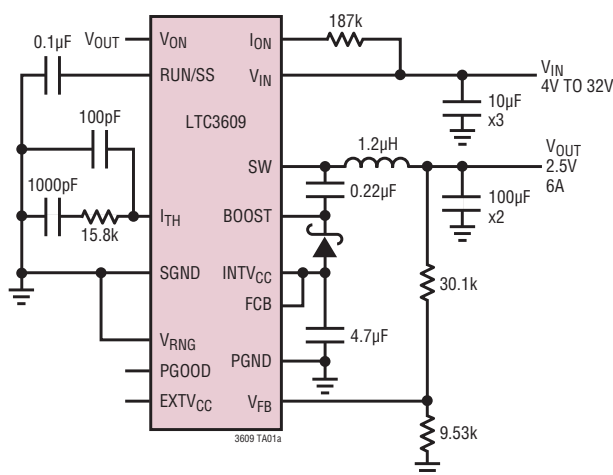

Efficiency and Power Loss vs Load Current

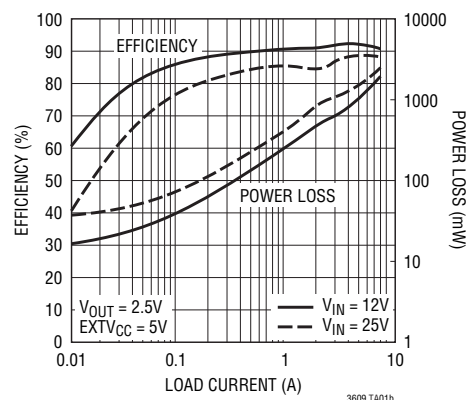

ABSOLUTE MAXIMUM RATINGS

(Note 1)

Input Supply Voltage (SV_{IN} , PV_{IN} , I_{ON}).....	36V to -0.3V
Boosted Topside Driver Supply Voltage (BOOST)	42V to -0.3V
SW Voltage	36V to -0.3V
$INTV_{CC}$, $EXTV_{CC}$, (BOOST - SW), RUN/SS, PGOOD Voltages	7V to -0.3V
FCB, V_{ON} , V_{RNG} Voltages.....	$INTV_{CC} + 0.3V$ to -0.3V
I_{TH} , V_{FB} Voltages	2.7V to -0.3V
Operating Junction Temperature Range (Notes 2, 4).....	-40°C to 125°C
Storage Temperature Range.....	-55°C to 125°C

PIN CONFIGURATION

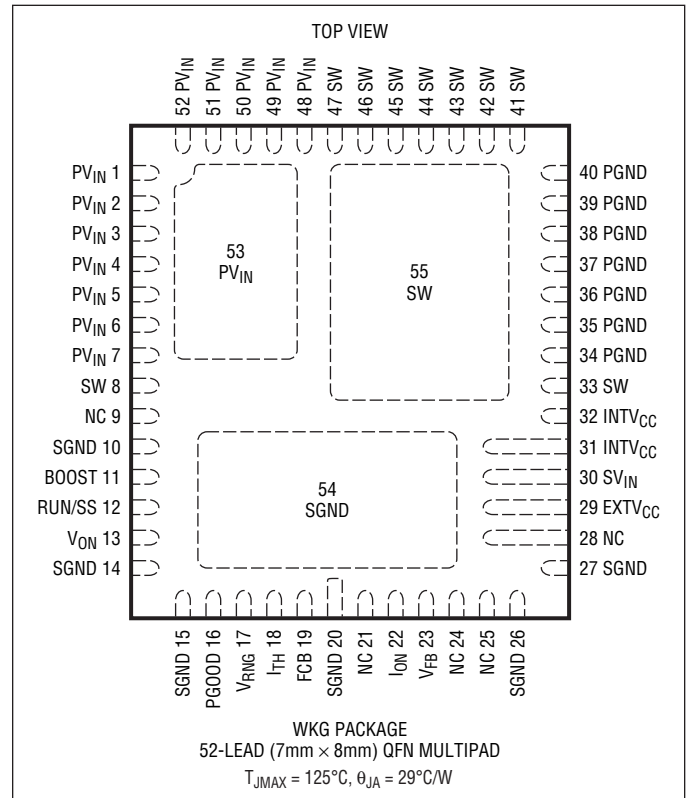

ORDER INFORMATION

LEAD FREE FINISH	TAPE AND REEL	PART MARKING*	PACKAGE DESCRIPTION	TEMPERATURE RANGE
LTC3609EWKG#PBF	LTC3609EWKG#TRPBF	LTC3609WKG	52-Lead (7mm x 8mm) Plastic QFN	-40°C to 125°C
LTC3609IWKG#PBF	LTC3609IWKG#TRPBF	LTC3609WKG	52-Lead (7mm x 8mm) Plastic QFN	-40°C to 125°C

Consult LTC Marketing for parts specified with wider operating temperature ranges. *The temperature grade is identified by a label on the shipping container. Consult LTC Marketing for information on non-standard lead based finish parts.

For more information on lead free part marking, go to: <http://www.linear.com/leadfree/>

For more information on tape and reel specifications, go to: <http://www.linear.com/tapeandreeel/>

ELECTRICAL CHARACTERISTICS

The ● denotes the specifications which apply over the full operating junction temperature range, otherwise specifications are at $T_A = 25^\circ\text{C}$. $V_{IN} = 15\text{V}$ unless otherwise noted.

SYMBOL	PARAMETER	CONDITIONS	MIN	TYP	MAX	UNITS	
Main Control Loop							
SV_{IN}	Operating Input Voltage Range		4		32	V	
I_Q	Input DC Supply Current			900	2000	μA	
	Normal Shutdown Supply Current			15	30	μA	
V_{FB}	Feedback Reference Voltage	$I_{TH} = 1.2\text{V}$ (Note 3)		0.600	0.606	V	
		-40°C to 85°C	●	0.594	0.600	V	
		-40°C to 125°C	●	0.590	0.610	V	
$\Delta V_{FB(LINEREG)}$	Feedback Voltage Line Regulation	$V_{IN} = 4\text{V}$ to 30V , $I_{TH} = 1.2\text{V}$ (Note 3)		0.002		%/V	
$\Delta V_{FB(LOADREG)}$	Feedback Voltage Load Regulation	$I_{TH} = 0.5\text{V}$ to 1.9V (Note 3)		-0.05	-0.3	%	
I_{FB}	Feedback Input Current	$V_{FB} = 0.6\text{V}$		-5	± 50	nA	
$g_{m(EA)}$	Error Amplifier Transconductance	$I_{TH} = 1.2\text{V}$ (Note 3)	●	1.4	1.7	2	mS
V_{FCB}	Forced Continuous Threshold		●	0.54	0.6	0.66	V
I_{FCB}	Forced Continuous Pin Current	$V_{FCB} = 0.6\text{V}$		-1	-2	μA	
t_{ON}	On-Time	$I_{ON} = 60\mu\text{A}$, $V_{ON} = 1.5\text{V}$		220	280	340	ns
		$I_{ON} = 60\mu\text{A}$, $V_{ON} = 0\text{V}$			110		ns
$t_{ON(MIN)}$	Minimum On-Time	$I_{ON} = 180\mu\text{A}$, $V_{ON} = 0\text{V}$		60	100	ns	
$t_{OFF(MIN)}$	Minimum Off-Time	$I_{ON} = 30\mu\text{A}$, $V_{ON} = 1.5\text{V}$		320	500	ns	
$I_{VALLEY(MAX)}$	Maximum Valley Current	$V_{RNG} = 0\text{V}$, $V_{FB} = 0.56\text{V}$, $FCB = 0\text{V}$	●	4	9		A
		$V_{RNG} = 1.2\text{V}$, $V_{FB} = 0.56\text{V}$, $FCB = 0\text{V}$	●	6	14		A
$I_{VALLEY(MIN)}$	Maximum Reverse Valley Current	$V_{RNG} = 0\text{V}$, $V_{FB} = 0.64\text{V}$, $FCB = 0\text{V}$			4		A
		$V_{RNG} = 1.2\text{V}$, $V_{FB} = 0.64\text{V}$, $FCB = 0\text{V}$			7		A
$\Delta V_{FB(OV)}$	Output Overvoltage Fault Threshold			7	10	13	%
$V_{RUN/SS(ON)}$	RUN Pin Start Threshold		●	0.8	1.5	2	V
$V_{RUN/SS(LE)}$	RUN Pin Latchoff Enable Threshold	RUN/SS Pin Rising			4	4.5	V
$V_{RUN/SS(LT)}$	RUN Pin Latchoff Threshold	RUN/SS Pin Falling			3.5	4.2	V
$I_{RUN/SS(C)}$	Soft-Start Charge Current	$V_{RUN/SS} = 0\text{V}$		-0.5	-1.2	-3	μA
$I_{RUN/SS(D)}$	Soft-Start Discharge Current	$V_{RUN/SS} = 4.5\text{V}$, $V_{FB} = 0\text{V}$		0.8	1.8	3	μA
$V_{IN(UVLO)}$	Undervoltage Lockout	V_{IN} Falling	●		3.4	3.9	V
$V_{IN(UVLOR)}$	Undervoltage Lockout Release	V_{IN} Rising	●		3.5	4	V
$R_{DS(ON)}$	Top Switch On-Resistance				18	27	$\text{m}\Omega$
	Bottom Switch On-Resistance				13	22	$\text{m}\Omega$

ELECTRICAL CHARACTERISTICS

The ● denotes the specifications which apply over the full operating junction temperature range, otherwise specifications are at $T_A = 25^\circ\text{C}$. $V_{IN} = 15\text{V}$ unless otherwise noted.

SYMBOL	PARAMETER	CONDITIONS	MIN	TYP	MAX	UNITS	
Internal V_{CC} Regulator							
V_{INTVCC}	Internal V_{CC} Voltage	$6\text{V} < V_{IN} < 30\text{V}$, $V_{EXTVCC} = 4\text{V}$	●	4.7	5	5.5	V
$\Delta V_{LDO}(\text{LOADREG})$	Internal V_{CC} Load Regulation	$I_{CC} = 0\text{mA}$ to 20mA , $V_{EXTVCC} = 4\text{V}$		-0.1	± 2		%
V_{EXTVCC}	EXTV _{CC} Switchover Voltage	$I_{CC} = 20\text{mA}$, V_{EXTVCC} Rising	●	4.5	4.7		V
ΔV_{EXTVCC}	EXTV _{CC} Switch Drop Voltage	$I_{CC} = 20\text{mA}$, $V_{EXTVCC} = 5\text{V}$		150	300		mV
$\Delta V_{EXTVCC}(\text{HYS})$	EXTV _{CC} Switchover Hysteresis			500			mV
PGOOD Output							
ΔV_{FBH}	PGOOD Upper Threshold	V_{FB} Rising		7	10	13	%
ΔV_{FBL}	PGOOD Lower Threshold	V_{FB} Falling		-7	-10	-13	%
$\Delta V_{FB}(\text{HYS})$	PGOOD Hysteresis	V_{FB} Returning		1	2.5		%
V_{PGL}	PGOOD Low Voltage	$I_{PGOOD} = 5\text{mA}$		0.15	0.4		V

Note 1: Stresses beyond those listed under Absolute Maximum Ratings may cause permanent damage to the device. Exposure to any Absolute Maximum Rating condition for extended periods may affect device reliability and lifetime.

Note 2: T_J is calculated from the ambient temperature T_A and power dissipation P_D as follows:

$$T_J = T_A + (P_D \cdot 29^\circ\text{C/W}) \quad (\theta_{JA} \text{ is simulated per JESD51-7 high effective thermal conductivity test board}).$$

$$\theta_{JC} = 1^\circ\text{C/W} \quad (\theta_{JC} \text{ is simulated when heat sink is applied at the bottom of the package}).$$

Note 3: The LTC3609 is tested in a feedback loop that adjusts V_{FB} to achieve a specified error amplifier output voltage (I_{TH}). The specification at 85°C is not tested in production. This specification is assured by design, characterization, and correlation to testing at 125°C .

Note 4: The LTC3609 is tested under pulsed load conditions such that $T_J \approx T_A$. The LTC3609E is guaranteed to meet specifications from 0°C to 125°C junction temperature. Specifications over the -40°C to 125°C operating junction temperature range are assured by design, characterization and correlation with statistical process controls. The LTC3609I is guaranteed over the full -40°C to 125°C operating junction temperature range. Note that the maximum ambient temperature consistent with these specifications is determined by specific operating conditions in conjunction with board layout, the rated package thermal impedance and other environmental factors.

TYPICAL PERFORMANCE CHARACTERISTICS

Transient Response

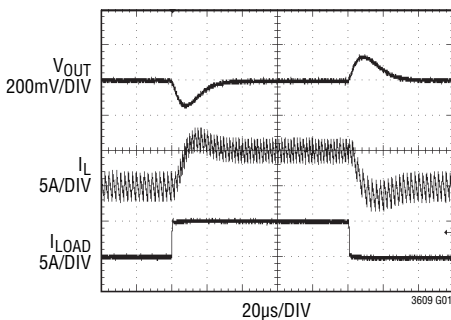

LOAD STEP 0A TO 5A
 $V_{IN} = 25\text{V}$
 $V_{OUT} = 2.5\text{V}$
 $FCB = 0\text{V}$
 FIGURE 6 CIRCUIT

Transient Response (Discontinuous Mode)

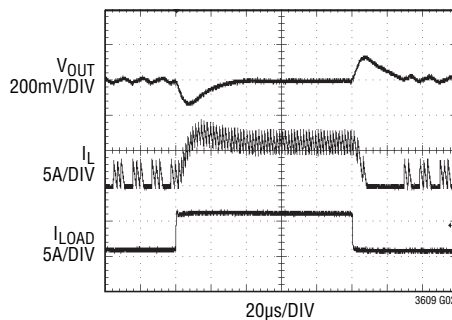

LOAD STEP 1A TO 6A
 $V_{IN} = 25\text{V}$
 $V_{OUT} = 2.5\text{V}$
 $FCB = INTV_{CC}$
 FIGURE 6 CIRCUIT

Start-Up

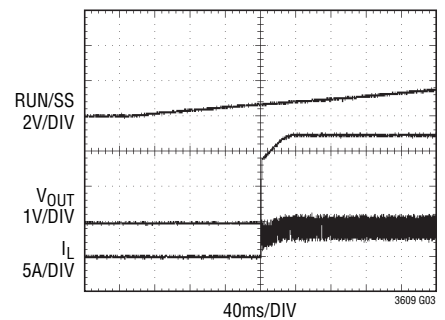

$V_{IN} = 12\text{V}$
 $V_{OUT} = 2.5\text{V}$
 $R_{LOAD} = 0.5\Omega$
 FIGURE 6 CIRCUIT

TYPICAL PERFORMANCE CHARACTERISTICS

Efficiency vs Load Current

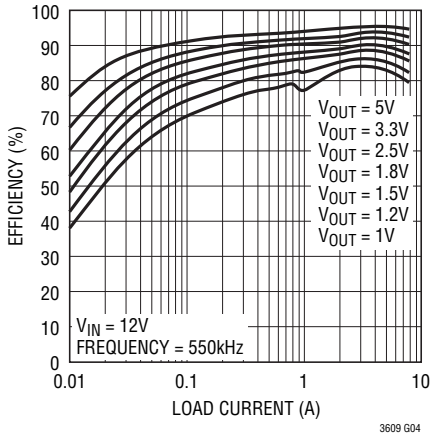

Efficiency vs Input Voltage

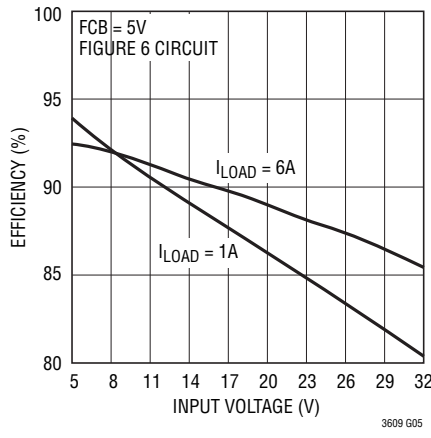

Frequency vs Input Voltage

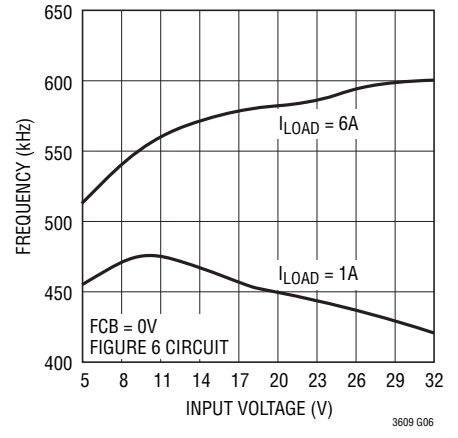

Frequency vs Load Current

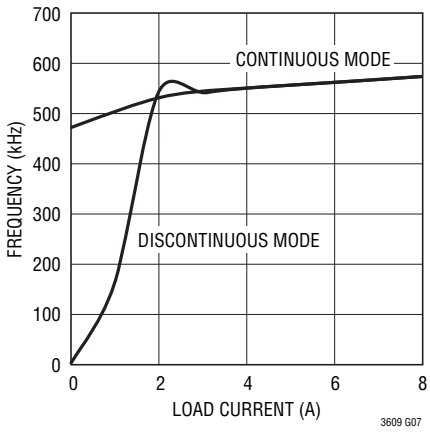

Load Regulation

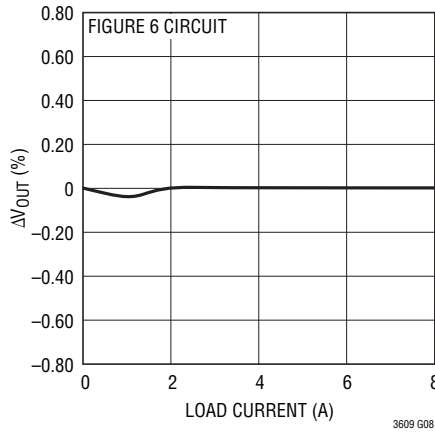

I_{TH} Voltage vs Load Current

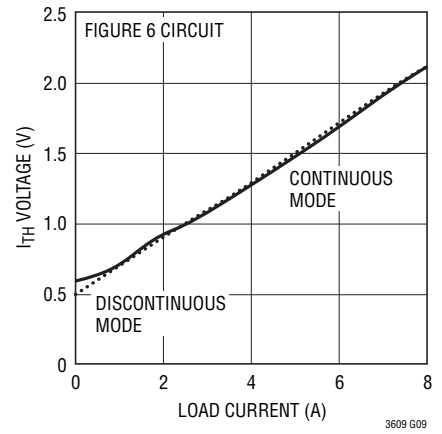

Load Current vs I_{TH} Voltage at Different V_{RNG}

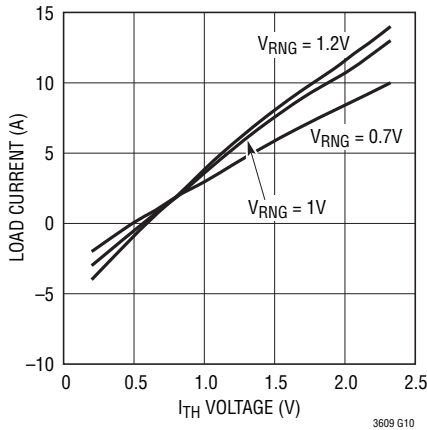

On-Time vs I_{ON} Current

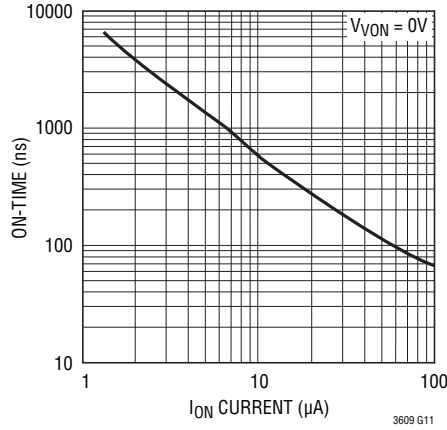

On-Time vs V_{ON} Voltage

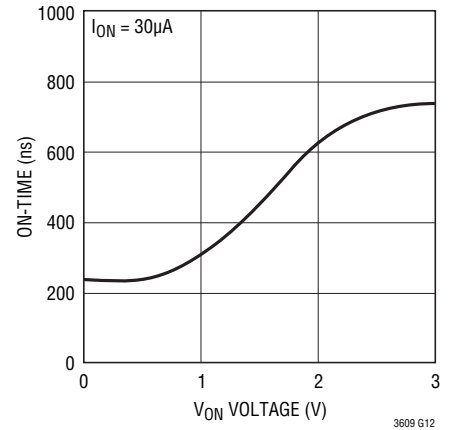

TYPICAL PERFORMANCE CHARACTERISTICS

On-Time vs Temperature

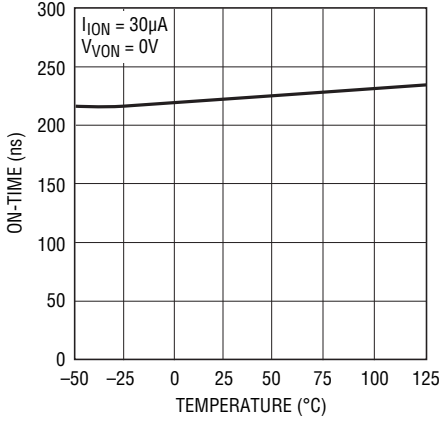

3609 G13

Maximum Valley Current Limit vs V_{RNG} Voltage

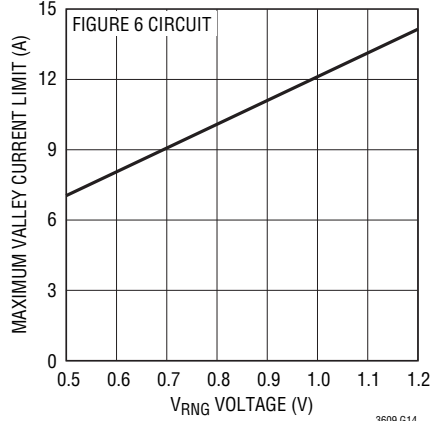

3609 G14

Maximum Valley Current Limit vs RUN/SS Voltage

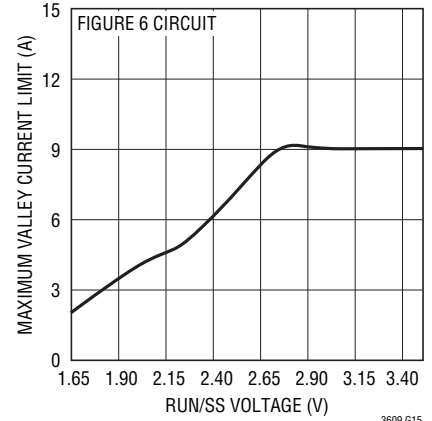

3609 G15

Maximum Valley Current Limit vs Temperature

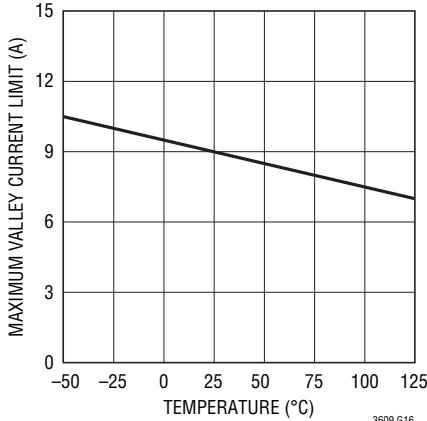

3609 G16

Maximum Valley Current vs Input Voltage

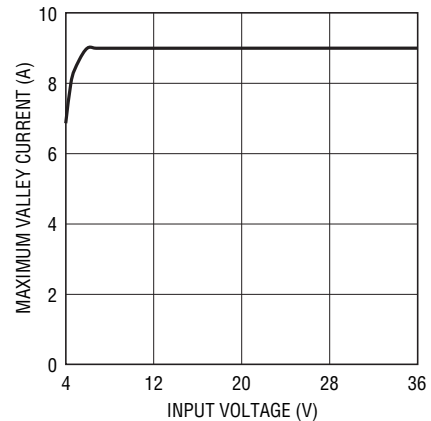

3609 G17

Maximum Valley Current Limit in Foldback

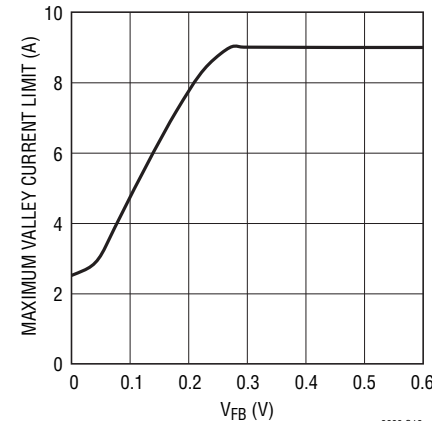

3609 G18

Feedback Reference Voltage vs Temperature

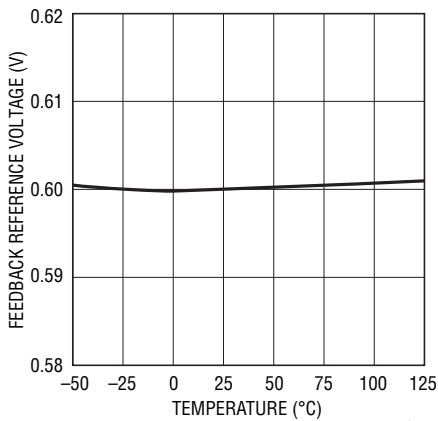

3609 G19

Error Amplifier g_m vs Temperature

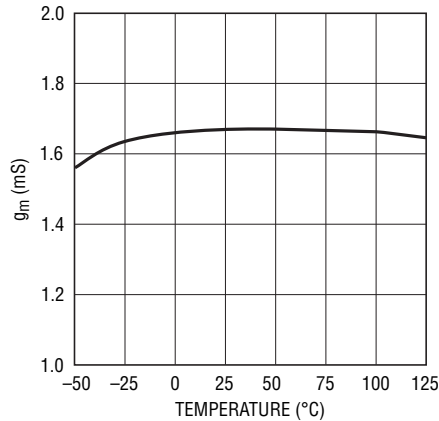

3609 G20

Input and Shutdown Currents vs Input Voltage

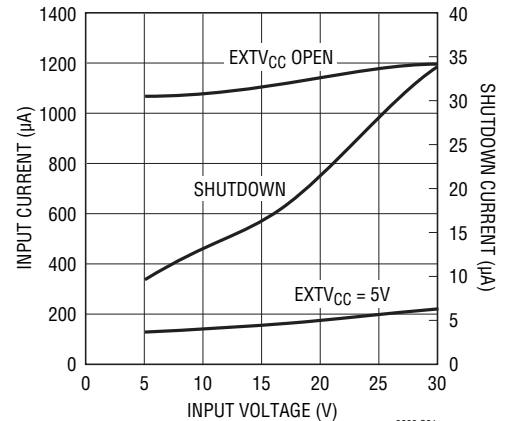

3609 G21

TYPICAL PERFORMANCE CHARACTERISTICS

INTV_{CC} Load Regulation

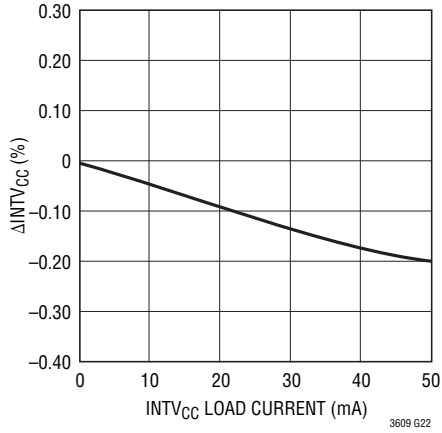

EXTV_{CC} Switch Resistance vs Temperature

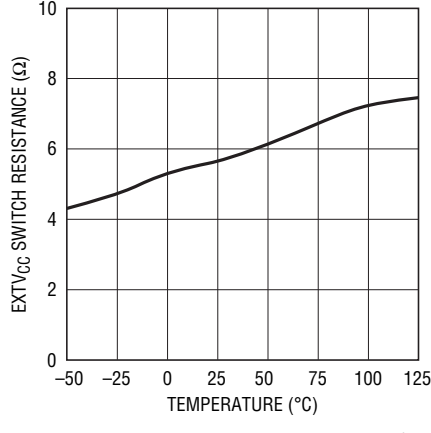

I_{EXTVCC} vs Frequency

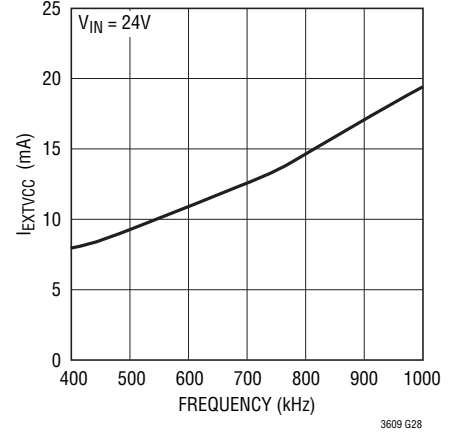

FCB Pin Current vs Temperature

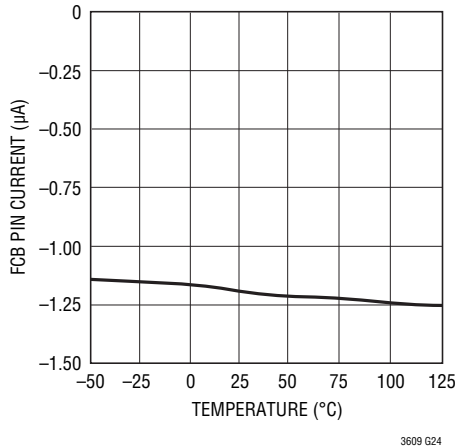

RUN/SS Pin Current vs Temperature

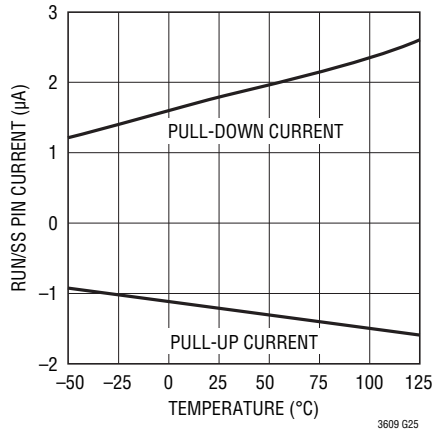

RUN/SS Pin Current vs Temperature

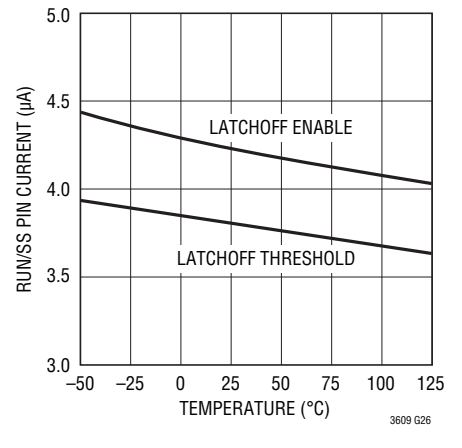

Undervoltage Lockout Threshold vs Temperature

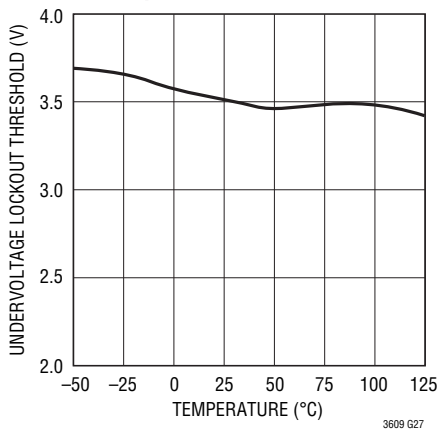

Load Step

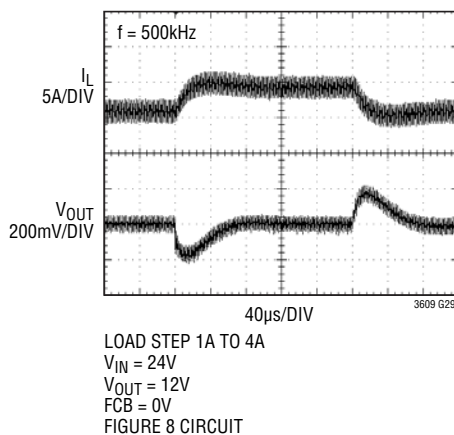

Efficiency vs Load Current

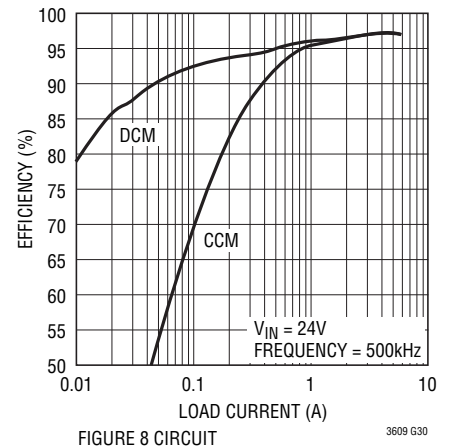

PIN FUNCTIONS

PV_{IN} (Pins 1, 2, 3, 4, 5, 6, 7, 48, 49, 50, 51, 52, 53): Main Input Supply. Decouple this pin to power PGND with the input capacitance, C_{IN}.

SW (Pins 8, 33, 41, 42, 43, 44, 45, 46, 47, 55): Switch Node Connection to the Inductor. The (–) terminal of the bootstrap capacitor, C_B, also connects here. This pin swings from a diode voltage drop below ground up to V_{IN}.

NC (Pins 9, 21, 24, 25, 28): No Connection.

SGND (Pins 10, 14, 15, 20, 26, 27, 54): Signal Ground. All small-signal components and compensation components should connect to this ground, which in turn connects to PGND at one point.

BOOST (Pin 11): Boosted Floating Driver Supply. The (+) terminal of the bootstrap capacitor, C_B, connects here. This pin swings from a diode voltage drop below INTV_{CC} up to V_{IN} + INTV_{CC}.

RUN/SS (Pin 12): Run Control and Soft-Start Input. A capacitor to ground at this pin sets the ramp time to full output current (approximately 3s/μF) and the time delay for overcurrent latchoff (see Applications Information). Forcing this pin below 0.8V shuts down the device.

V_{ON} (Pin 13): On-Time Voltage Input. Voltage trip point for the on-time comparator. Tying this pin to the output voltage or an external resistive divider from the output makes the on-time proportional to V_{OUT}. The comparator input defaults to 0.7V when the pin is grounded and defaults to 2.4V when the pin is tied to INTV_{CC}. Tie this pin to INTV_{CC} in high V_{OUT} applications to use a lower R_{ON} value.

PGOOD (Pin 16): Power Good Output. Open-drain logic output that is pulled to ground when the output voltage is not within ±10% of the regulation point.

V_{RNG} (Pin 17): Current Limit Range Input. The voltage at this pin adjusts maximum valley current and can be set from 0.7V to 1.2V by a resistive divider from INTV_{CC}. It defaults to 0.7V if the V_{RNG} pin is tied to ground which results in a typical 9A current limit.

I_{TH} (Pin 18): Current Control Threshold and Error Amplifier Compensation Point. The current comparator threshold increases with this control voltage. The voltage ranges from 0V to 2.4V with 0.8V corresponding to zero sense voltage (zero current).

FCB (Pin 19): Forced Continuous Input. Tie this pin to ground to force continuous synchronous operation at low load, to INTV_{CC} to enable discontinuous mode operation at low load or to a resistive divider from a secondary output when using a secondary winding.

I_{ON} (Pin 22): On-Time Current Input. Tie a resistor from V_{IN} to this pin to set the one-shot timer current and thereby set the switching frequency.

V_{FB} (Pin 23): Error Amplifier Feedback Input. This pin connects the error amplifier input to an external resistive divider from V_{OUT}.

EXTV_{CC} (Pin 29): External V_{CC} Input. When EXTV_{CC} exceeds 4.7V, an internal switch connects this pin to INTV_{CC} and shuts down the internal regulator so that controller and gate drive power is drawn from EXTV_{CC}. Do not exceed 7V at this pin and ensure that EXTV_{CC} < V_{IN}.

SV_{IN} (Pin 30): Supply Pin for Internal PWM Controller.

INTV_{CC} (Pins 31, 32): Internal 5V Regulator Output. The driver and control circuits are powered from this voltage. Decouple this pin to power ground with a minimum of 4.7μF low ESR tantalum or ceramic capacitor.

PGND (Pins 34, 35, 36, 37, 38, 39, 40): Power Ground. Connect this pin closely to the (–) terminal of C_{VCC} and the (–) terminal of C_{IN}.

FUNCTIONAL DIAGRAM

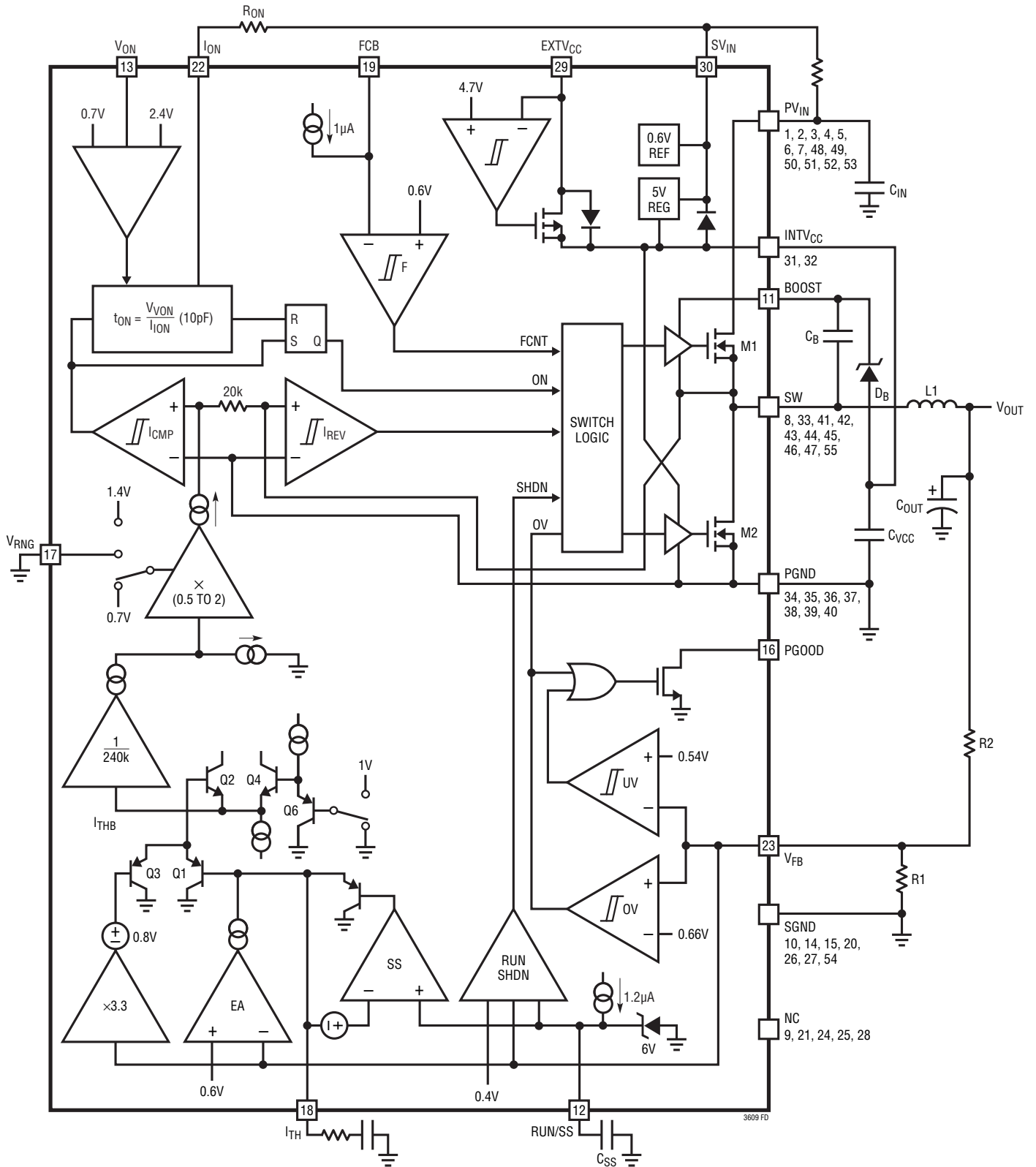

OPERATION

Main Control Loop

The LTC3609 is a high efficiency monolithic synchronous, step-down DC/DC converter utilizing a constant on-time, current mode architecture. It operates from an input voltage range of 4V to 32V/36V maximum and provides a regulated output voltage at up to 6A of output current. The internal synchronous power switch increases efficiency and eliminates the need for an external Schottky diode. In normal operation, the top MOSFET is turned on for a fixed interval determined by a one-shot timer OST. When the top MOSFET is turned off, the bottom MOSFET is turned on until the current comparator I_{CMP} trips, restarting the one-shot timer and initiating the next cycle. Inductor current is determined by sensing the voltage between the PGND and SW pins using the bottom MOSFET on-resistance. The voltage on the I_{TH} pin sets the comparator threshold corresponding to inductor valley current. The error amplifier, EA, adjusts this voltage by comparing the feedback signal V_{FB} from the output voltage with an internal 0.6V reference. If the load current increases, it causes a drop in the feedback voltage relative to the reference. The I_{TH} voltage then rises until the average inductor current again matches the load current.

At light load, the inductor current can drop to zero and become negative. This is detected by current reversal comparator I_{REV} which then shuts off M2 (see Functional Diagram), resulting in discontinuous operation. Both switches will remain off with the output capacitor supplying the load current until the I_{TH} voltage rises above the zero current level (0.8V) to initiate another cycle. Discontinuous mode operation is disabled by comparator F when the FCB pin is brought below 0.6V, forcing continuous synchronous operation.

The operating frequency is determined implicitly by the top MOSFET on-time and the duty cycle required to maintain regulation. The one-shot timer generates an on-time that is proportional to the ideal duty cycle, thus holding frequency approximately constant with changes in V_{IN} . The nominal frequency can be adjusted with an external resistor, R_{ON} .

Overvoltage and undervoltage comparators OV and UV pull the PGOOD output low if the output feedback voltage exits a $\pm 10\%$ window around the regulation point. Furthermore, in an overvoltage condition, M1 is turned off and M2 is turned on and held on until the overvoltage condition clears.

Foldback current limiting is provided if the output is shorted to ground. As V_{FB} drops, the buffered current threshold voltage I_{THB} is pulled down by clamp Q3 to a 1V level set by Q4 and Q6. This reduces the inductor valley current level to one sixth of its maximum value as V_{FB} approaches 0V.

Pulling the RUN/SS pin low forces the controller into its shutdown state, turning off both M1 and M2. Releasing the pin allows an internal 1.2 μ A current source to charge up an external soft-start capacitor, C_{SS} . When this voltage reaches 1.5V, the controller turns on and begins switching, but with the I_{TH} voltage clamped at approximately 0.6V below the RUN/SS voltage. As C_{SS} continues to charge, the soft-start current limit is removed.

INTV_{CC}/EXTV_{CC} Power

Power for the top and bottom MOSFET drivers and most of the internal controller circuitry is derived from the INTV_{CC} pin. The top MOSFET driver is powered from a floating bootstrap capacitor, C_B . This capacitor is recharged from INTV_{CC} through an external Schottky diode, D_B , when the top MOSFET is turned off. When the EXTV_{CC} pin is grounded, an internal 5V low dropout regulator supplies the INTV_{CC} power from V_{IN} . If EXTV_{CC} rises above 4.7V, the internal regulator is turned off, and an internal switch connects EXTV_{CC} to INTV_{CC}. This allows a high efficiency source connected to EXTV_{CC}, such as an external 5V supply or a secondary output from the converter, to provide the INTV_{CC} power. Voltages up to 7V can be applied to EXTV_{CC} for additional gate drive. If the input voltage is low and INTV_{CC} drops below 3.5V, undervoltage lockout circuitry prevents the power switches from turning on.

APPLICATIONS INFORMATION

The basic LTC3609 application circuit is shown on the front page of this data sheet. External component selection is primarily determined by the maximum load current. The LTC3609 uses the on-resistance of the synchronous power MOSFET for determining the inductor current. The desired amount of ripple current and operating frequency also determines the inductor value. Finally, C_{IN} is selected for its ability to handle the large RMS current into the converter and C_{OUT} is chosen with low enough ESR to meet the output voltage ripple and transient specification.

V_{ON} and PGOOD

The LTC3609 has an open-drain PGOOD output that indicates when the output voltage is within $\pm 10\%$ of the regulation point. The LTC3609 also has a V_{ON} pin that allows the on-time to be adjusted. Tying the V_{ON} pin high results in lower values for R_{ON} which is useful in high V_{OUT} applications. The V_{ON} pin also provides a means to adjust the on-time to maintain constant frequency operation in applications where V_{OUT} changes and to correct minor frequency shifts with changes in load current.

V_{RNG} Pin and I_{LIMIT} Adjust

The V_{RNG} pin is used to adjust the maximum inductor valley current, which in turn determines the maximum average output current that the LTC3609 can deliver. The maximum output current is given by:

$$I_{OUT(MAX)} = I_{VALLEY(MAX)} + 1/2 \Delta I_L$$

The $I_{VALLEY(MAX)}$ is shown in the figure “Maximum Valley Current Limit vs V_{RNG} Voltage” in the Typical Performance Characteristics.

An external resistor divider from $INTV_{CC}$ can be used to set the voltage on the V_{RNG} pin from 0.7V to 1.2V, or it can be simply tied to ground for a default value equivalent to 0.7V. When setting current limit, ensure that the junction temperature does not exceed the maximum rating of 125°C. Do not float the V_{RNG} pin.

Operating Frequency

The choice of operating frequency is a tradeoff between efficiency and component size. Low frequency operation improves efficiency by reducing MOSFET switching losses but requires larger inductance and/or capacitance in order to maintain low output ripple voltage.

The operating frequency of LTC3609 applications is determined implicitly by the one-shot timer that controls the on-time, t_{ON} , of the top MOSFET switch. The on-time is set by the current into the I_{ON} pin and the voltage at the V_{ON} pin according to:

$$t_{ON} = \frac{V_{VON}}{I_{ION}} (10pF)$$

Tying a resistor R_{ON} from V_{IN} to the I_{ON} pin yields an on-time inversely proportional to V_{IN} . The current out of the I_{ON} pin is:

$$I_{ION} = \frac{V_{IN}}{R_{ON}}$$

For a step-down converter, this results in approximately constant frequency operation as the input supply varies:

$$f = \frac{V_{OUT}}{V_{VON} R_{ON} (10pF)} [Hz]$$

To hold frequency constant during output voltage changes, tie the V_{ON} pin to V_{OUT} or to a resistive divider from V_{OUT} when $V_{OUT} > 2.4V$. The V_{ON} pin has internal clamps that limit its input to the one-shot timer. If the pin is tied below 0.7V, the input to the one-shot is clamped at 0.7V. Similarly, if the pin is tied above 2.4V, the input is clamped at 2.4V. In high V_{OUT} applications, tying V_{ON} to $INTV_{CC}$ so that the comparator input is 2.4V results in a lower value for R_{ON} . Figures 1a and 1b show how R_{ON} relates to switching frequency for several common output voltages.

APPLICATIONS INFORMATION

Because the voltage at the I_{ON} pin is about 0.7V, the current into this pin is not exactly inversely proportional to V_{IN} , especially in applications with lower input voltages. To correct for this error, an additional resistor R_{ON2} connected from the I_{ON} pin to the 5V $INTV_{CC}$ supply will further stabilize the frequency.

$$R_{ON2} = \frac{5V}{0.7V} R_{ON}$$

Changes in the load current magnitude will also cause frequency shift. Parasitic resistance in the MOSFET switches and inductor reduce the effective voltage across the inductance, resulting in increased duty cycle as the

load current increases. By lengthening the on-time slightly as current increases, constant frequency operation can be maintained. This is accomplished with a resistive divider from the I_{TH} pin to the V_{ON} pin and V_{OUT} . The values required will depend on the parasitic resistances in the specific application. A good starting point is to feed about 25% of the voltage change at the I_{TH} pin to the V_{ON} pin as shown in Figure 2a. Place capacitance on the V_{ON} pin to filter out the I_{TH} variations at the switching frequency. The resistor load on I_{TH} reduces the DC gain of the error amp and degrades load regulation, which can be avoided by using the PNP emitter follower of Figure 2b.

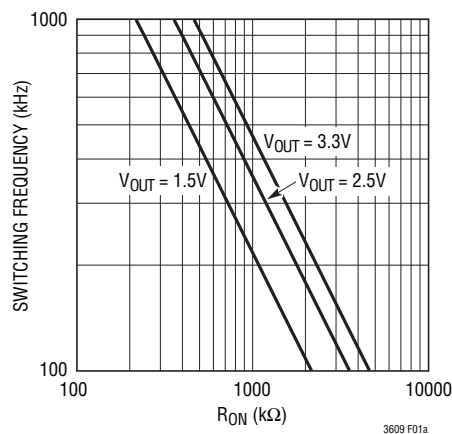

Figure 1a. Switching Frequency vs R_{ON} ($V_{ON} = 0V$)

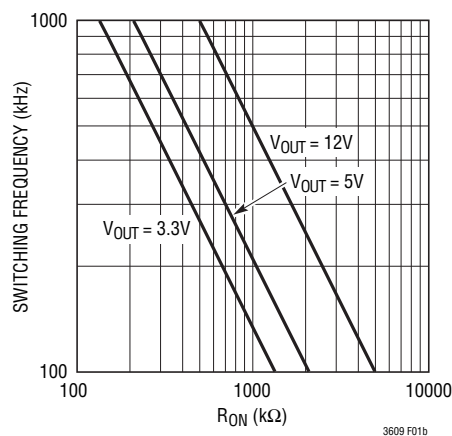

Figure 1b. Switching Frequency vs R_{ON} ($V_{ON} = INTV_{CC}$)

APPLICATIONS INFORMATION

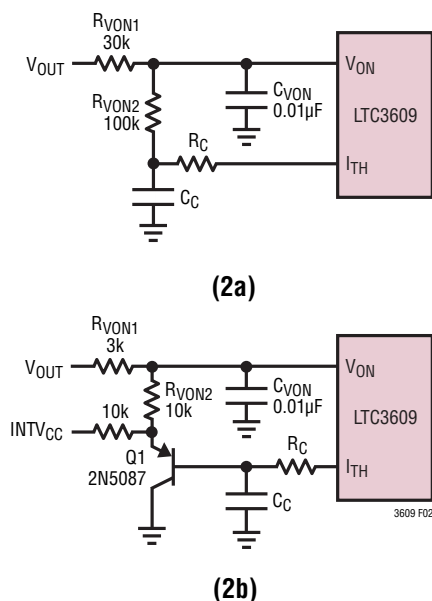

Figure 2. Correcting Frequency Shift with Load Current Changes

Minimum Off-time and Dropout Operation

The minimum off-time, $t_{OFF(MIN)}$, is the smallest amount of time that the LTC3609 is capable of turning on the bottom MOSFET, tripping the current comparator and turning the MOSFET back off. This time is generally about 250ns. The minimum off-time limit imposes a maximum duty cycle of $t_{ON}/(t_{ON} + t_{OFF(MIN)})$. If the maximum duty cycle is reached, due to a dropping input voltage for example, then the output will drop out of regulation. The minimum input voltage to avoid dropout is:

$$V_{IN(MIN)} = V_{OUT} \frac{t_{ON} + t_{OFF(MIN)}}{t_{ON}}$$

A plot of maximum duty cycle vs frequency is shown in Figure 3.

Setting the Output Voltage

The LTC3609 develops a 0.6V reference voltage between the feedback pin, V_{FB} , and the signal ground as shown in Figure 6. The output voltage is set by a resistive divider according to the following formula:

$$V_{OUT} = 0.6V \left(1 + \frac{R2}{R1} \right)$$

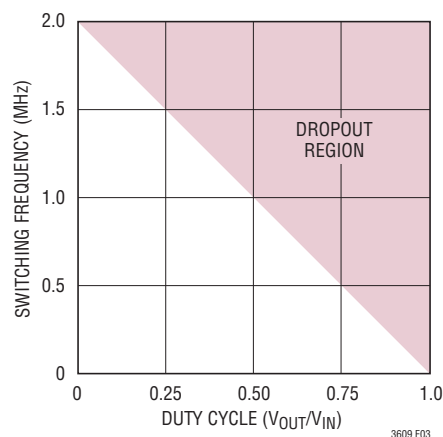

Figure 3. Maximum Switching Frequency vs Duty Cycle

To improve the frequency response, a feed-forward capacitor, $C1$, may also be used. Great care should be taken to route the V_{FB} line away from noise sources, such as the inductor or the SW line.

Inductor Selection

Given the desired input and output voltages, the inductor value and operating frequency determine the ripple current:

$$\Delta I_L = \left(\frac{V_{OUT}}{f L} \right) \left(1 - \frac{V_{OUT}}{V_{IN}} \right)$$

Lower ripple current reduces core losses in the inductor, ESR losses in the output capacitors and output voltage ripple. Highest efficiency operation is obtained at low frequency with small ripple current. However, achieving this requires a large inductor. There is a tradeoff between component size, efficiency and operating frequency.

A reasonable starting point is to choose a ripple current that is about 40% of $I_{OUT(MAX)}$. The largest ripple current occurs at the highest V_{IN} . To guarantee that ripple current does not exceed a specified maximum, the inductance should be chosen according to:

$$L = \left(\frac{V_{OUT}}{f \Delta I_{L(MAX)}} \right) \left(1 - \frac{V_{OUT}}{V_{IN(MAX)}} \right)$$

APPLICATIONS INFORMATION

Once the value for L is known, the type of inductor must be selected. High efficiency converters generally cannot afford the core loss found in low cost powdered iron cores. A variety of inductors designed for high current, low voltage applications are available from manufacturers such as Sumida, Panasonic, Coiltronics, Coilcraft and Toko.

C_{IN} and C_{OUT} Selection

The input capacitance, C_{IN} , is required to filter the square wave current at the drain of the top MOSFET. Use a low ESR capacitor sized to handle the maximum RMS current.

$$I_{RMS} \cong I_{OUT(MAX)} \frac{V_{OUT}}{V_{IN}} \sqrt{\frac{V_{IN}}{V_{OUT}} - 1}$$

This formula has a maximum at $V_{IN} = 2V_{OUT}$, where $I_{RMS} = I_{OUT(MAX)}/2$. This simple worst-case condition is commonly used for design because even significant deviations do not offer much relief. Note that ripple current ratings from capacitor manufacturers are often based on only 2000 hours of life which makes it advisable to derate the capacitor.

The selection of C_{OUT} is primarily determined by the ESR required to minimize voltage ripple and load step transients. The output ripple ΔV_{OUT} is approximately bounded by:

$$\Delta V_{OUT} \leq \Delta I_L \left(ESR + \frac{1}{8fC_{OUT}} \right)$$

Since ΔI_L increases with input voltage, the output ripple is highest at maximum input voltage. Typically, once the ESR requirement is satisfied, the capacitance is adequate for filtering and has the necessary RMS current rating.

Multiple capacitors placed in parallel may be needed to meet the ESR and RMS current handling requirements. Dry tantalum, special polymer, aluminum electrolytic and ceramic capacitors are all available in surface mount packages. Special polymer capacitors offer very low ESR but have lower capacitance density than other types. Tantalum

capacitors have the highest capacitance density but it is important to only use types that have been surge tested for use in switching power supplies. Aluminum electrolytic capacitors have significantly higher ESR, but can be used in cost-sensitive applications providing that consideration is given to ripple current ratings and long-term reliability. Ceramic capacitors have excellent low ESR characteristics but can have a high voltage coefficient and audible piezoelectric effects. The high Q of ceramic capacitors with trace inductance can also lead to significant ringing. When used as input capacitors, care must be taken to ensure that ringing from inrush currents and switching does not pose an overvoltage hazard to the power switches and controller. To dampen input voltage transients, add a small 5 μ F to 50 μ F aluminum electrolytic capacitor with an ESR in the range of 0.5 Ω to 2 Ω . High performance through-hole capacitors may also be used, but an additional ceramic capacitor in parallel is recommended to reduce the effect of their lead inductance.

Top MOSFET Driver Supply (C_B , D_B)

An external bootstrap capacitor, C_B , connected to the BOOST pin supplies the gate drive voltage for the topside MOSFET. This capacitor is charged through diode D_B from $INTV_{CC}$ when the switch node is low. When the top MOSFET turns on, the switch node rises to V_{IN} and the BOOST pin rises to approximately $V_{IN} + INTV_{CC}$. The boost capacitor needs to store about 100 times the gate charge required by the top MOSFET. In most applications an 0.1 μ F to 0.47 μ F, X5R or X7R dielectric capacitor is adequate.

Discontinuous Mode Operation and FCB Pin

The FCB pin determines whether the bottom MOSFET remains on when current reverses in the inductor. Tying this pin above its 0.6V threshold enables discontinuous operation where the bottom MOSFET turns off when inductor current reverses. The load current at which current reverses and discontinuous operation begins depends on the amplitude of the inductor ripple current and will vary

APPLICATIONS INFORMATION

with changes in V_{IN} . Tying the FCB pin below the 0.6V threshold forces continuous synchronous operation, allowing current to reverse at light loads and maintaining high frequency operation.

In addition to providing a logic input to force continuous operation, the FCB pin provides a means to maintain a flyback winding output when the primary is operating in discontinuous mode. The secondary output V_{OUT2} is normally set as shown in Figure 4 by the turns ratio N of the transformer. However, if the controller goes into discontinuous mode and halts switching due to a light primary load current, then V_{OUT2} will droop. An external resistor divider from V_{OUT2} to the FCB pin sets a minimum voltage $V_{OUT2(MIN)}$ below which continuous operation is forced until V_{OUT2} has risen above its minimum:

$$V_{OUT2(MIN)} = 0.6V \left(1 + \frac{R4}{R3} \right)$$

Fault Conditions: Current Limit and Foldback

The LTC3609 has a current mode controller which inherently limits the cycle-by-cycle inductor current not only in steady-state operation but also in transient. To further limit current in the event of a short circuit to ground, the LTC3609 includes foldback current limiting. If the output falls by more than 25%, then the maximum sense voltage is progressively lowered to about one sixth of its full value.

INTV_{CC} Regulator and EXTV_{CC} Connection

An internal P-channel low dropout regulator produces the 5V supply that powers the drivers and internal circuitry within the LTC3609. The INTV_{CC} pin can supply up to 50mA RMS and must be bypassed to ground with a minimum of 4.7 μ F tantalum or ceramic capacitor. Good bypassing is necessary to supply the high transient currents required by the MOSFET gate drivers.

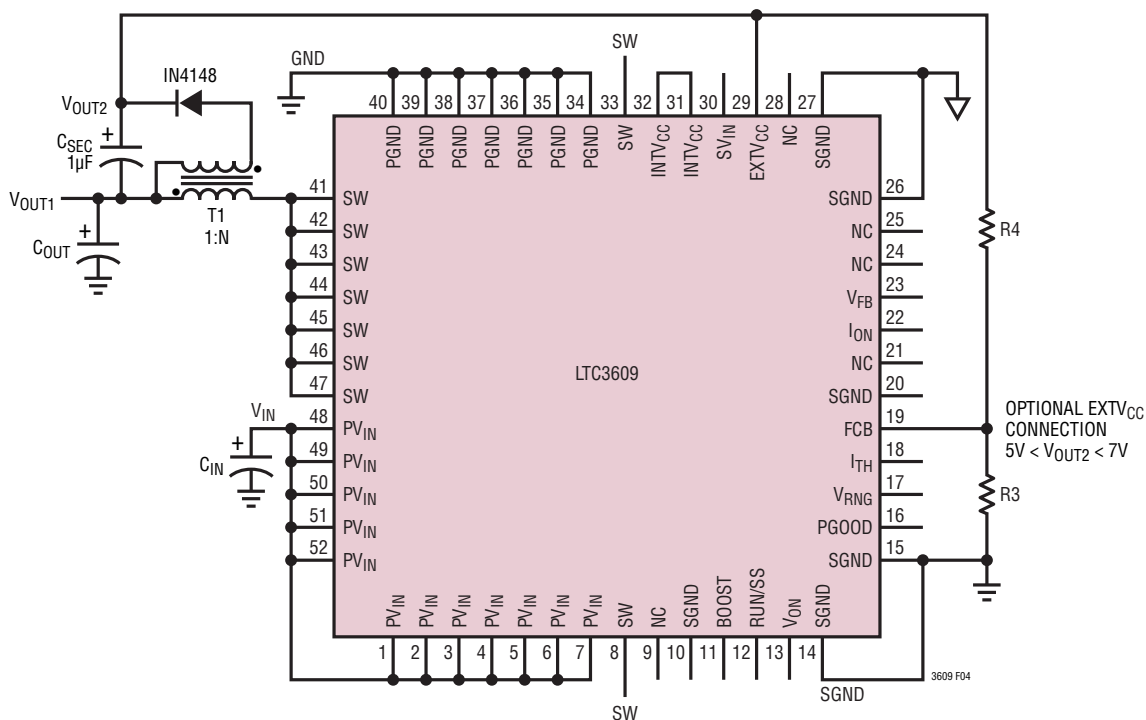

Figure 4. Secondary Output Loop and EXTV_{CC} Connection

APPLICATIONS INFORMATION

The EXTV_{CC} pin can be used to provide MOSFET gate drive and control power from the output or another external source during normal operation. Whenever the EXTV_{CC} pin is above 4.7V the internal 5V regulator is shut off and an internal 50mA P-channel switch connects the EXTV_{CC} pin to INTV_{CC}. INTV_{CC} power is supplied from EXTV_{CC} until this pin drops below 4.5V. Do not apply more than 7V to the EXTV_{CC} pin and ensure that EXTV_{CC} ≤ V_{IN}. The following list summarizes the possible connections for EXTV_{CC}:

1. EXTV_{CC} grounded. INTV_{CC} is always powered from the internal 5V regulator.
2. EXTV_{CC} connected to an external supply. A high efficiency supply compatible with the MOSFET gate drive requirements (typically 5V) can improve overall efficiency.
3. EXTV_{CC} connected to an output derived boost network. The low voltage output can be boosted using a charge pump or flyback winding to greater than 4.7V. The system will start-up using the internal linear regulator until the boosted output supply is available.

Soft-Start and Latchoff with the RUN/SS Pin

The RUN/SS pin provides a means to shut down the LTC3609 as well as a timer for soft-start and overcurrent latchoff. Pulling the RUN/SS pin below 0.8V puts the LTC3609 into a low quiescent current shutdown ($I_Q < 30\mu\text{A}$). Releasing the pin allows an internal 1.2μA current source to charge up the external timing capacitor, C_{SS}. If RUN/SS has been pulled all the way to ground, there is a delay before starting of about:

$$t_{\text{DELAY}} = \frac{1.5\text{V}}{1.2\mu\text{A}} C_{\text{SS}} = (1.3\text{s}/\mu\text{F}) C_{\text{SS}}$$

When the voltage on RUN/SS reaches 1.5V, the LTC3609 begins operating with a clamp on I_{TH} of approximately 0.9V. As the RUN/SS voltage rises to 3V, the clamp on I_{TH} is raised until its full 2.4V range is available. This takes an

additional 1.3s/μF, during which the load current is folded back until the output reaches 75% of its final value.

After the controller has been started and given adequate time to charge up the output capacitor, C_{SS} is used as a short-circuit timer. After the RUN/SS pin charges above 4V, if the output voltage falls below 75% of its regulated value, then a short-circuit fault is assumed. A 1.8μA current then begins discharging C_{SS}. If the fault condition persists until the RUN/SS pin drops to 3.5V, then the controller turns off both power MOSFETs, shutting down the converter permanently. The RUN/SS pin must be actively pulled down to ground in order to restart operation.

The overcurrent protection timer requires that the soft-start timing capacitor, C_{SS}, be made large enough to guarantee that the output is in regulation by the time C_{SS} has reached the 4V threshold. In general, this will depend upon the size of the output capacitance, output voltage and load current characteristic. A minimum soft-start capacitor can be estimated from:

$$C_{\text{SS}} > C_{\text{OUT}} V_{\text{OUT}} R_{\text{SENSE}} (10^{-4} [\text{F/V s}])$$

Generally 0.1μF is more than sufficient.

Overcurrent latchoff operation is not always needed or desired. Load current is already limited during a short circuit by the current foldback circuitry and latchoff operation can prove annoying during troubleshooting. The feature can be overridden by adding a pull-up current greater than 5μA to the RUN/SS pin. The additional current prevents the discharge of C_{SS} during a fault and also shortens the soft-start period. Using a resistor to V_{IN} as shown in Figure 5a is simple, but slightly increases shutdown current. Connecting a resistor to INTV_{CC} as shown in Figure 5b eliminates the additional shutdown current, but requires a diode to isolate C_{SS}. Any pull-up network must be able to pull RUN/SS above the 4.2V maximum threshold of the latchoff circuit and overcome the 4μA maximum discharge current.

APPLICATIONS INFORMATION

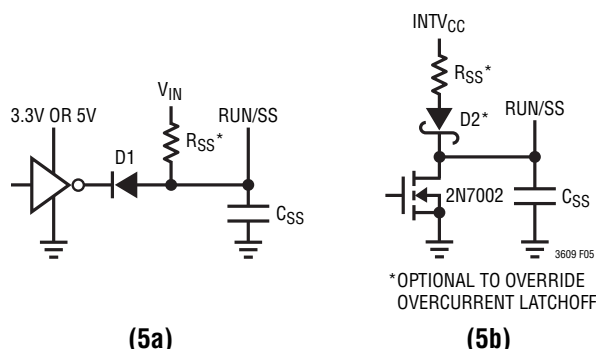

Figure 5. RUN/SS Pin Interfacing with Latchoff Defeated

Efficiency Considerations

The percent efficiency of a switching regulator is equal to the output power divided by the input power times 100%. It is often useful to analyze individual losses to determine what is limiting the efficiency and which change would produce the most improvement. Although all dissipative elements in the circuit produce losses, four main sources account for most of the losses in LTC3609 circuits:

1. DC I^2R losses. These arise from the resistance of the internal resistance of the MOSFETs, inductor and PC board traces and cause the efficiency to drop at high output currents. In continuous mode the average output current flows through L, but is chopped between the top and bottom MOSFETs. The DC I^2R loss for one MOSFET can simply be determined by $[R_{DS(ON)} + R_L] \cdot I_O$.
2. Transition loss. This loss arises from the brief amount of time the top MOSFET spends in the saturated region during switch node transitions. It depends upon the input voltage, load current, driver strength and MOSFET capacitance, among other factors. The loss is significant at input voltages above 20V and can be estimated from:

$$\text{Transition Loss} \cong (1.7A^{-1}) V_{IN}^2 I_{OUT} C_{RSS} f$$

3. $INTV_{CC}$ current. This is the sum of the MOSFET driver and control currents. This loss can be reduced by supplying $INTV_{CC}$ current through the $EXTV_{CC}$ pin from a high efficiency source, such as an output derived boost network or alternate supply if available.

4. C_{IN} loss. The input capacitor has the difficult job of filtering the large RMS input current to the regulator. It must have a very low ESR to minimize the AC I^2R loss and sufficient capacitance to prevent the RMS current from causing additional upstream losses in fuses or batteries.

Other losses, including C_{OUT} ESR loss, Schottky diode D1 conduction loss during dead time and inductor core loss generally account for less than 2% additional loss.

When making adjustments to improve efficiency, the input current is the best indicator of changes in efficiency. If you make a change and the input current decreases, then the efficiency has increased. If there is no change in input current, then there is no change in efficiency.

Checking Transient Response

The regulator loop response can be checked by looking at the load transient response. Switching regulators take several cycles to respond to a step in load current. When a load step occurs, V_{OUT} immediately shifts by an amount equal to ΔI_{LOAD} (ESR), where ESR is the effective series resistance of C_{OUT} . ΔI_{LOAD} also begins to charge or discharge C_{OUT} generating a feedback error signal used by the regulator to return V_{OUT} to its steady-state value. During this recovery time, V_{OUT} can be monitored for overshoot or ringing that would indicate a stability problem. The I_{TH} pin external components shown in Figure 6 will provide adequate compensation for most applications. For a detailed explanation of switching control loop theory see Application Note 76.

APPLICATIONS INFORMATION

Design Example

As a design example, take a supply with the following specifications: $V_{IN} = 5V$ to $32V$ (12V nominal), $V_{OUT} = 2.5V \pm 5\%$, $I_{OUT(MAX)} = 6A$, $f = 550kHz$. First, calculate the timing resistor with $V_{ON} = V_{OUT}$:

$$R_{ON} = \frac{2.5V}{(2.4V)(550kHz)(10pF)} = 187k$$

and choose the inductor for about 40% ripple current at the maximum V_{IN} :

$$L = \frac{2.5V}{(550kHz)(0.4)(6A)} \left(1 - \frac{2.5V}{32V}\right) = 1.8\mu H$$

Selecting a standard value of $1.5\mu H$ results in a maximum ripple current of:

$$\Delta I_L = \frac{2.5V}{(550kHz)(1.5\mu H)} \left(1 - \frac{2.5V}{12V}\right) = 2.4A$$

Next, set up V_{RNG} voltage and check the I_{LIMIT} . Tying V_{RNG} to GND will set the typical current limit to 9A, and tying V_{RNG} to 1.2V will result in a typical current around 14A.

C_{IN} is chosen for an RMS current rating of about 5A at $85^\circ C$. The ceramic output capacitors are chosen for an ESR of 0.002Ω to minimize output voltage changes due to inductor ripple current and load steps. The ripple voltage is:

$$\Delta V_{OUT(RIPPLE)} = \Delta I_{L(MAX)} (ESR) = (2.4A) (0.002\Omega) = 4.8mV$$

and a 0A to 6A load step will only cause an output change of:

$$\Delta V_{OUT(STEP)} = \Delta I_{LOAD} (ESR) = (6A) (0.002\Omega) = 12mV$$

An optional $22\mu F$ ceramic output capacitor is included to minimize the effect of ESL in the output ripple. The complete circuit is shown in Figure 6.

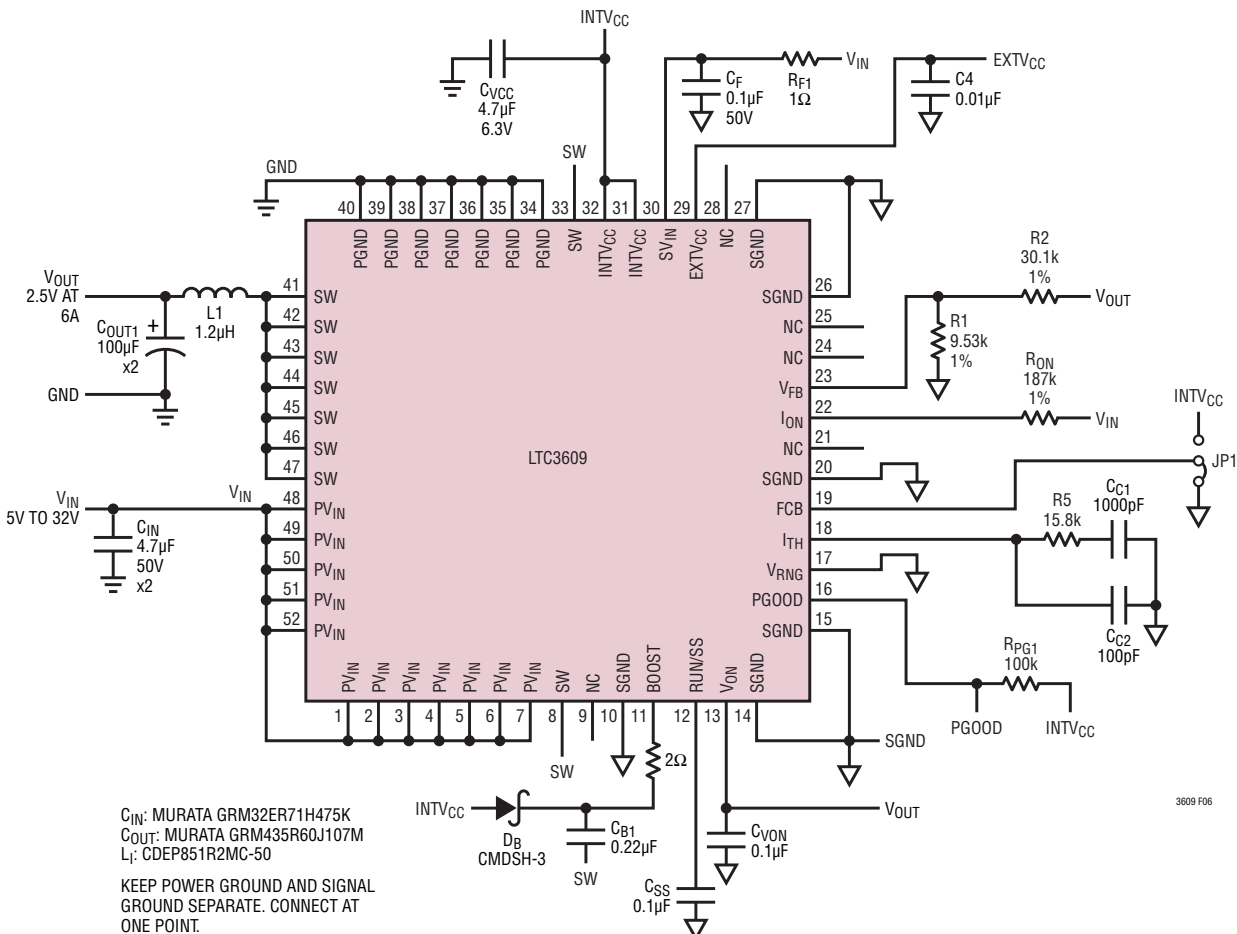

Figure 6. Design Example: 5V to 32V Input to 2.5V/6A at 550kHz

APPLICATIONS INFORMATION

How to Reduce SW Ringing

As with any switching regulator, there will be voltage ringing on the SW node, especially for high input voltages. The ringing amplitude and duration is dependent on the switching speed (gate drive), layout (parasitic inductance) and MOSFET output capacitance. This ringing contributes to the overall EMI, noise and high frequency ripple. One way to reduce ringing is to optimize layout. A good layout minimizes parasitic inductance. Adding RC snubbers from SW to GND is also an effective way to reduce ringing. Finally, adding a resistor in series with the BOOST pin will slow down the MOSFET turn-on slew rate to dampen ringing, but at the cost of reduced efficiency. Note that since the IC is buffered from the high frequency transients by PCB and bondwire inductances, the ringing by itself is normally not a concern for controller reliability.

PC Board Layout Checklist

When laying out a PC board follow one of the two suggested approaches. The simple PC board layout requires a dedicated ground plane layer. Also, for higher currents, a multilayer board is recommended to help with heat sinking of power components.

- The ground plane layer should not have any traces and it should be as close as possible to the layer with the LTC3609.
- Place C_{IN} and C_{OUT} all in one compact area, close to the LTC3609. It may help to have some components on the bottom side of the board.
- Keep small-signal components close to the LTC3609.
- Ground connections (including LTC3609 SGND and PGND) should be made through immediate vias to the ground plane. Use several larger vias for power components.
- Use a compact plane for the switch node (SW) to improve cooling of the MOSFETs and to keep EMI down.
- Use planes for V_{IN} and V_{OUT} to maintain good voltage filtering and to keep power losses low.
- Flood all unused areas on all layers with copper. Flooding with copper reduces the temperature rise of power components. Connect these copper areas to any DC net (V_{IN} , V_{OUT} , GND or to any other DC rail in your system).

When laying out a printed circuit board without a ground plane, use the following checklist to ensure proper operation of the controller. These items are also illustrated in Figure 7.

- Segregate the signal and power grounds. All small-signal components should return to the SGND pin at one point, which is then tied to the PGND pin.
- Connect the input capacitor(s), C_{IN} , close to the IC. This capacitor carries the MOSFET AC current.
- Keep the high dV/dt SW, BOOST and TG nodes away from sensitive small-signal nodes.
- Connect the INTV_{CC} decoupling capacitor, C_{VCC} , closely to the INTV_{CC} and PGND pins.
- Connect the top driver boost capacitor, C_B , closely to the BOOST and SW pins.
- Connect the V_{IN} pin decoupling capacitor, C_F , closely to the V_{IN} and PGND pins.

APPLICATIONS INFORMATION

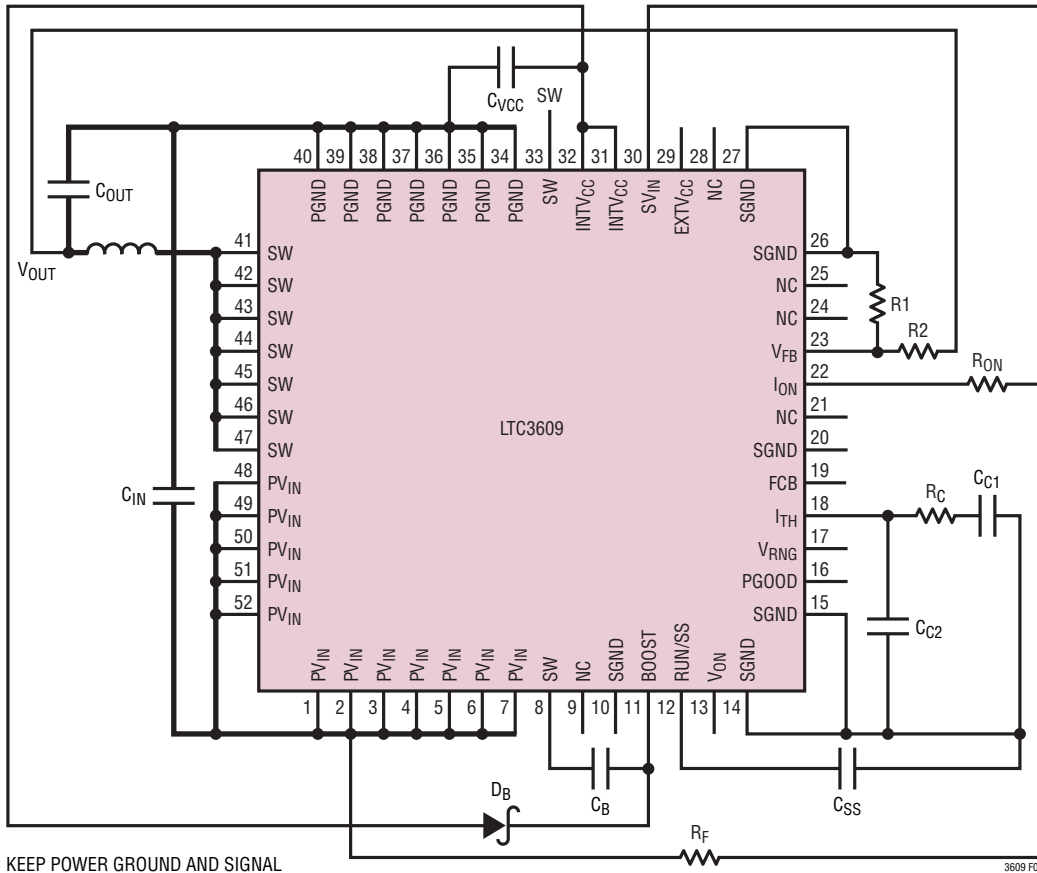

KEEP POWER GROUND AND SIGNAL GROUND SEPARATE. CONNECT AT ONE POINT.

Figure 7. LTC3609 Layout Diagram

3609 F07

TYPICAL APPLICATIONS

3.6V Input to 1.5V/6A at 750kHz

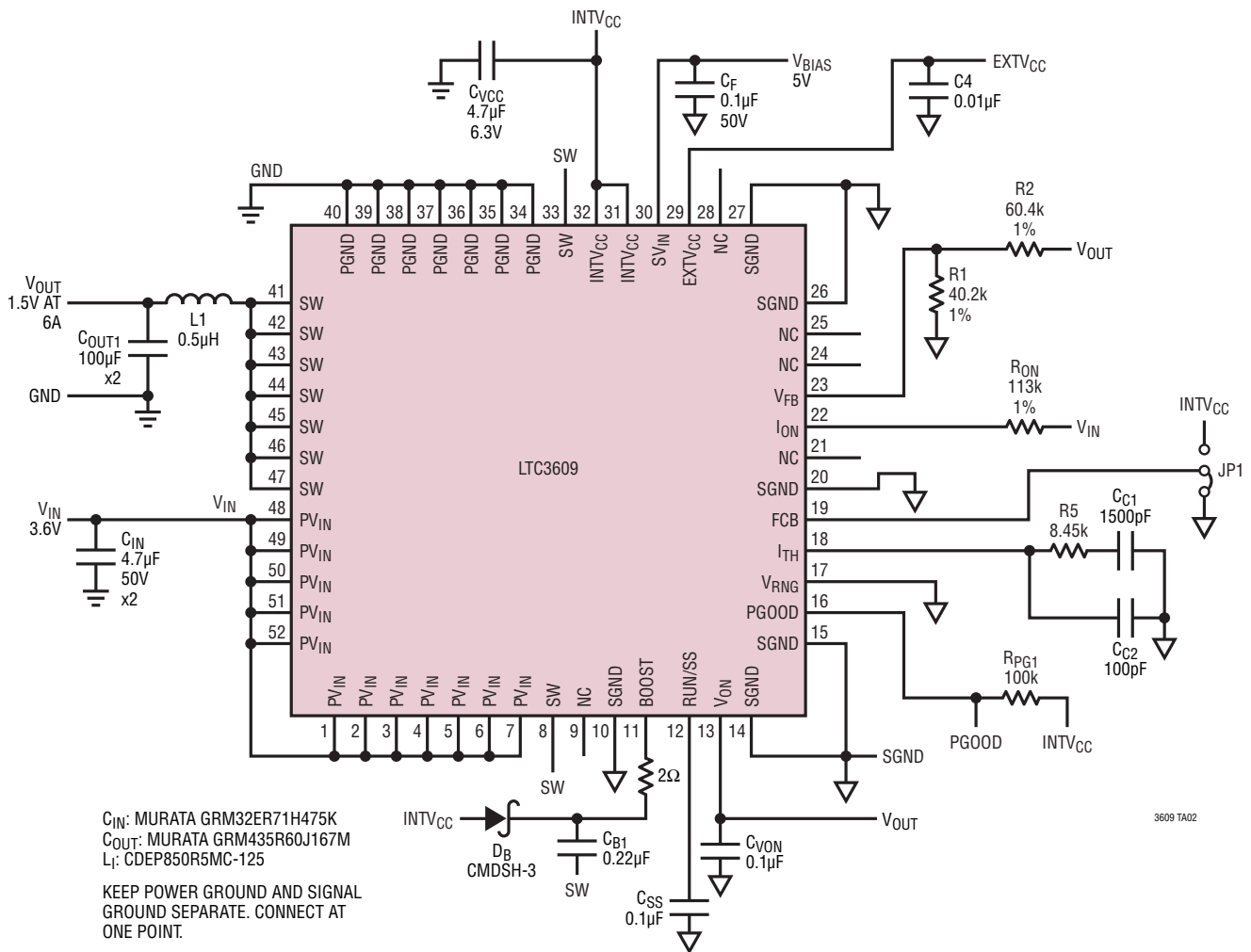

Transient Response

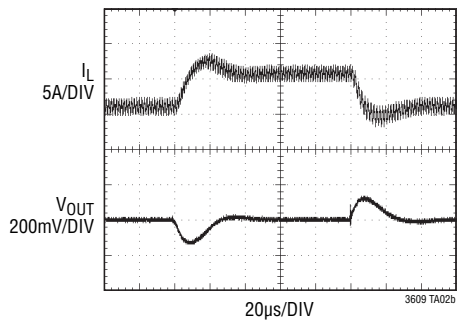

LOAD STEP 1A TO 5A
 $V_{IN} = 3.6V$
 $V_{OUT} = 1.5V$
 $FCB = 0V$

Efficiency vs Load Current

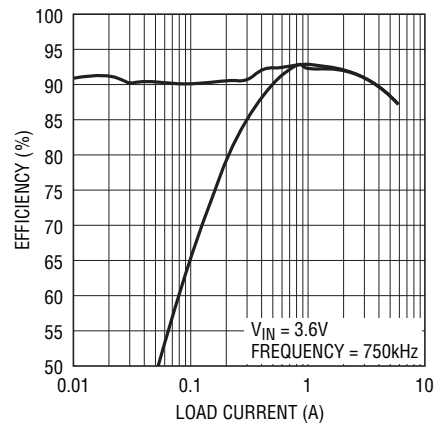

TYPICAL APPLICATIONS

5V to 32V Input to 1.2V/6A at 550kHz

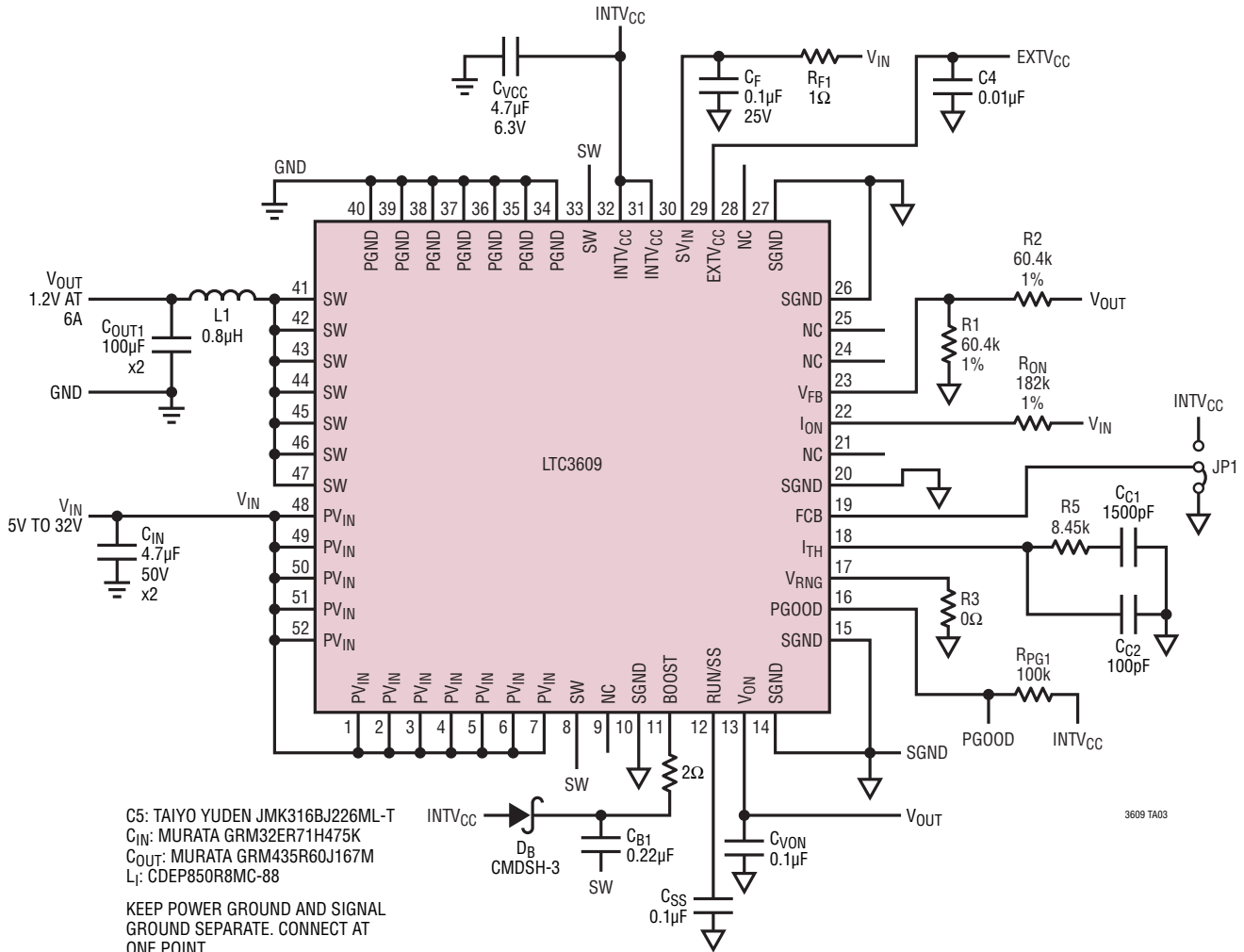

Transient Response

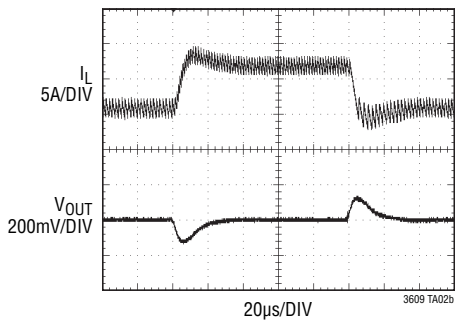

LOAD STEP 1A TO 6A
 $V_{IN} = 12V$
 $V_{OUT} = 1.2V$
 $FCB = 0V$

Efficiency vs Load Current

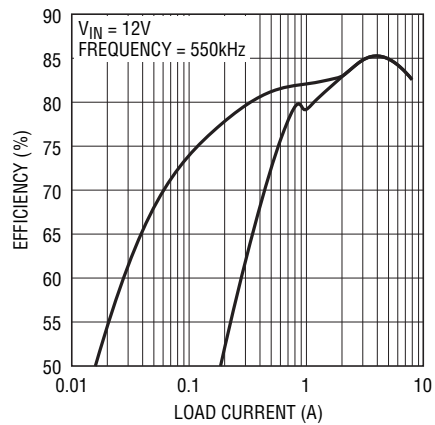

3609 TA02c

TYPICAL APPLICATIONS

5V to 32V Input to 1.8V/6A All Ceramic 1MHz

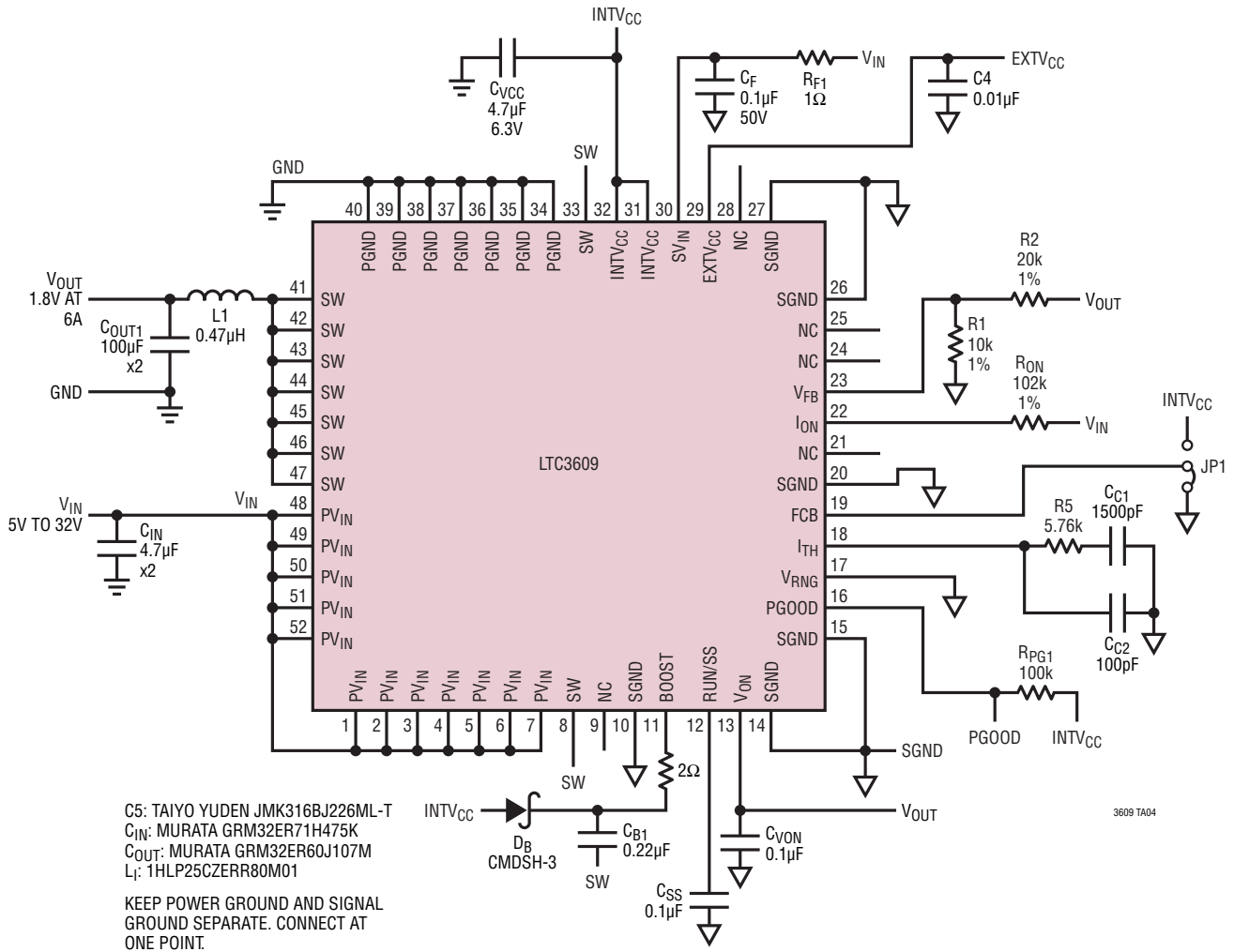

Transient Response

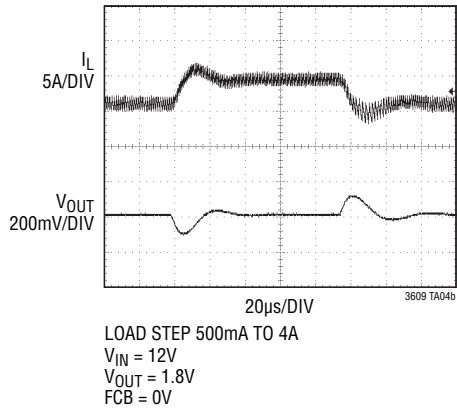

Efficiency vs Load Current

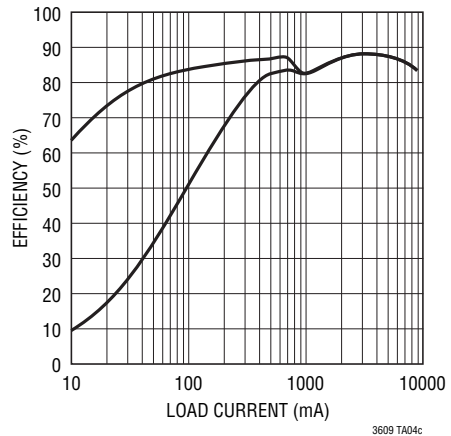

PACKAGE DESCRIPTION

WKG Package
52-Lead QFN Multipad (7mm × 8mm)
 (Reference LTC DWG # 05-08-1768 Rev 0)

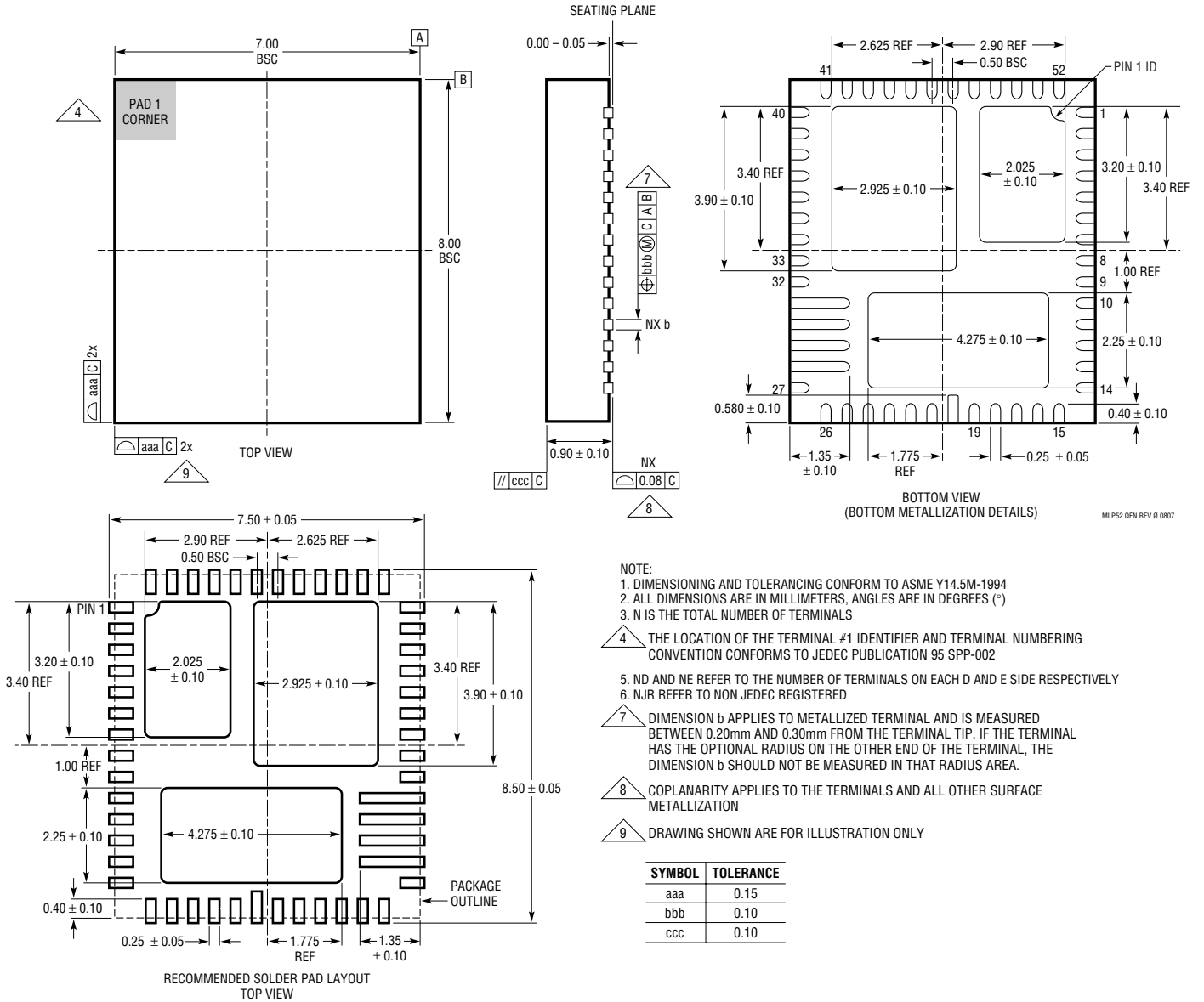

MLP52 QFN REV 0 0807

REVISION HISTORY (Revision history begins at Rev B)

REV	DATE	DESCRIPTION	PAGE NUMBER
B	06 /10	Updated SW voltage range in Absolute Maximum Ratings. Note 4 updated.	2 4

TYPICAL APPLICATION

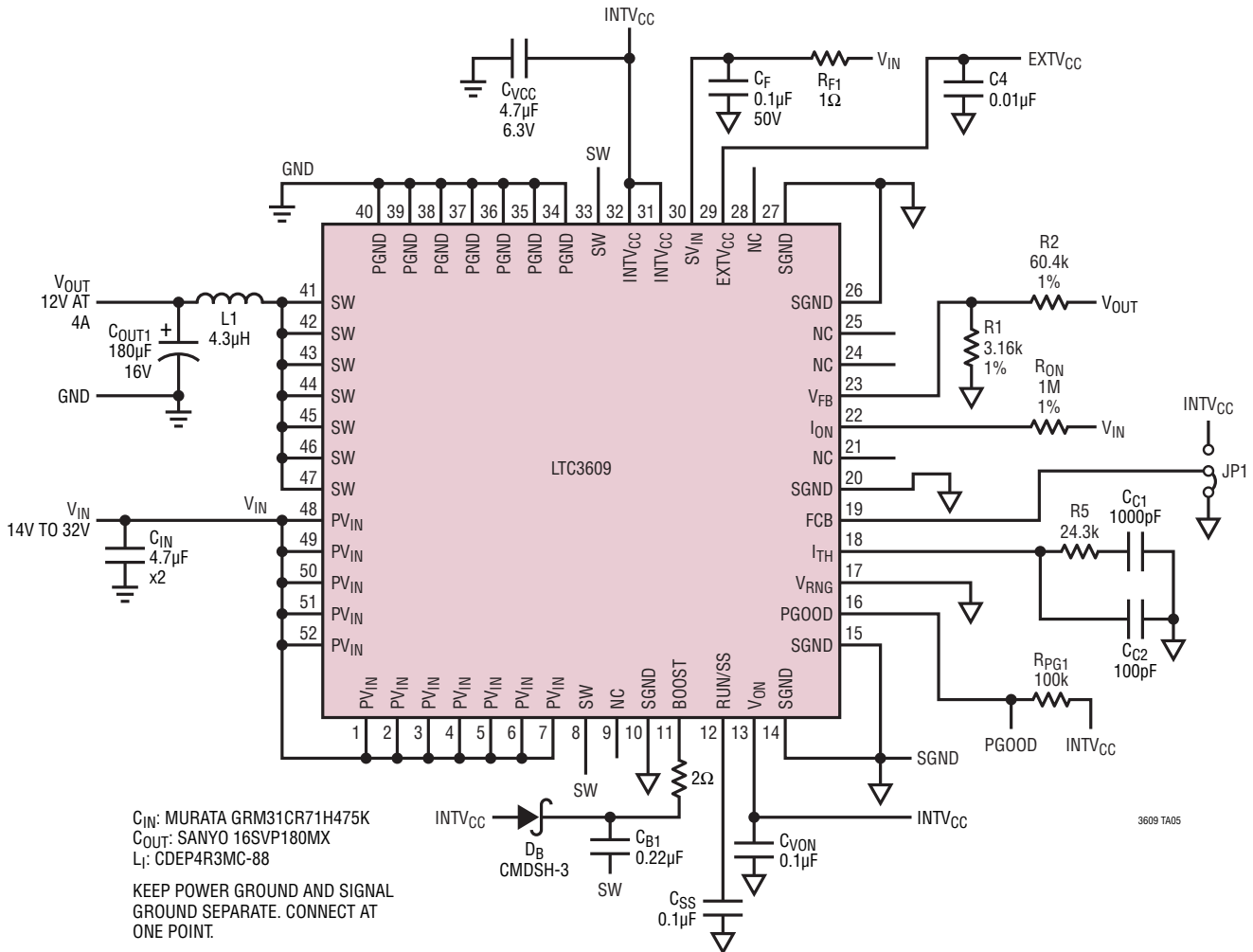

Figure 8. 14V to 32V Input to 12V/4A at 500kHz

RELATED PARTS

PART NUMBER	DESCRIPTION	COMMENTS
LTC3602	2.5A (I _{OUT}), 3MHz, Synchronous Step-Down DC/DC Converter	95% Efficiency, V _{IN} : 4.5V to 10V, V _{OUT(MIN)} = 0.6V, I _Q = 75μA, I _{SD} <1μA, 4mm × 4mm QFN-20, TSSOP-16E Packages
LTC3608	18V, 8A (I _{OUT}), 1MHz, Synchronous Step-Down DC/DC Converter	95% Efficiency, V _{IN} : 4V to 18V, V _{OUT(MIN)} = 0.6V, I _Q = 900μA, I _{SD} <15μA, 7mm × 8mm QFN-52 Package
LTC3610	24V, 12A (I _{OUT}), 1MHz, Synchronous Step-Down DC/DC Converter	95% Efficiency, V _{IN} : 4V to 24V, V _{OUT(MIN)} = 0.6V, I _Q = 900μA, I _{SD} <15μA, 9mm × 9mm QFN-64 Package
LTC3611	32V, 10A (I _{OUT}), 1MHz, Synchronous Step-Down DC/DC Converter	95% Efficiency, V _{IN} : 4V to 32V, V _{OUT(MIN)} = 0.6V, I _Q = 900μA, I _{SD} <15μA, 9mm × 9mm QFN-64 Package
LTC3414/ LTC3416	4A (I _{OUT}), 4MHz, Synchronous Step-Down DC/DC Converter	95% Efficiency, V _{IN} : 2.25V to 5.5V, V _{OUT(MIN)} = 0.8V, I _Q = 64μA, I _{SD} <1μA, TSSOP20E Package
LTC3415	7A (I _{OUT}), 1.5MHz, Synchronous Step-Down DC/DC Converter	95% Efficiency, V _{IN} : 2.5V to 5.5V, V _{OUT(MIN)} = 0.6V, I _Q = 450μA, I _{SD} <1μA, 5mm × 7mm QFN-38 Package
LTC3418	8A (I _{OUT}), 4MHz, Synchronous Step-Down DC/DC Converter	95% Efficiency, V _{IN} : 2.25V to 5.5V, V _{OUT(MIN)} = 0.8V, I _Q = 380μA, I _{SD} <1μA, 5mm × 7mm QFN-38 Package

3609fb

Looking for pricing, stock, or lifecycle information?

Click below to explore more details on WIN SOURCE:

 [View LTC3609IWKG#PBF on WIN SOURCE](#)

 [Linear Technology](#) Information

Optimize Your Supply Chain with WIN SOURCE Solutions

-  Global Sourcing Solution
-  Obsolete Management
-  Cost Control Management
-  Shortage Management
-  Alternative Solution
-  Excess Inventory Management