



**THE DATASHEET OF
LTC3803IS6#TRMPBF**



Constant Frequency Current Mode Flyback DC/DC Controller in ThinSOT

FEATURES

- V_{IN} and V_{OUT} Limited Only by External Components
- Adjustable Slope Compensation
- Internal Soft-Start
- Constant Frequency 200kHz Operation
- $\pm 1.5\%$ Reference Accuracy
- Current Mode Operation for Excellent Line and Load Transient Response
- No Minimum Load Requirement
- Low Quiescent Current: 240 μ A
- Low Profile (1mm) SOT-23 Package

APPLICATIONS

- Telecom Power Supplies
- 42V and 12V Automotive Power Supplies
- Auxiliary/Housekeeping Power Supplies
- Power Over Ethernet

LT, LTC, LTM, Burst Mode, Linear Technology and the Linear logo are registered trademarks and ThinSOT and No R_{SENSE} are trademarks of Linear Technology Corporation. All other trademarks are the property of their respective owners.

DESCRIPTION

The LTC[®]3803 is a constant frequency current mode flyback controller optimized for driving N-channel MOSFETs in high input voltage applications. Constant frequency operation is maintained down to very light loads, resulting in less low frequency noise generation over a wide range of load currents. Slope compensation can be programmed with an external resistor.

The LTC3803 provides $\pm 1.5\%$ output voltage accuracy and consumes only 240 μ A of quiescent current. Ground-referenced current sensing allows LTC3803-based converters to accept input supplies beyond the LTC3803's absolute maximum V_{CC} . A micropower hysteretic start-up feature allows efficient operation at high input voltages. For simplicity, the LTC3803 can also be powered from a high V_{IN} through a resistor, due to its internal shunt regulator. An internal undervoltage lockout shuts down the LTC3803 when the input voltage is too low to provide sufficient gate drive to the external MOSFET.

The LTC3803 is available in a low profile (1mm) 6-lead SOT-23 (ThinSOT[™]) package.

TYPICAL APPLICATION

5V Output Nonisolated Telecom Housekeeping Power Supply

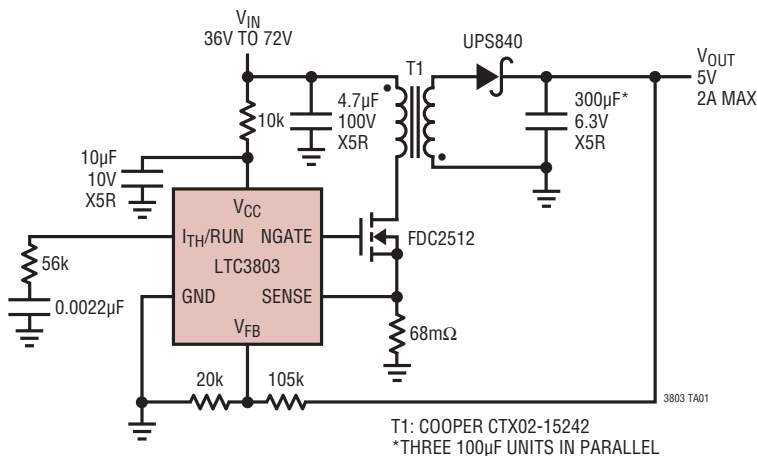

Efficiency vs Load Current

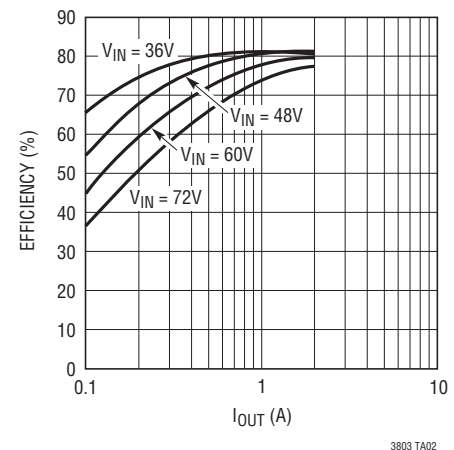

LTC3803

ABSOLUTE MAXIMUM RATINGS

(Note 1)

V_{CC} to GND	
Low Impedance Source	-0.3V to 8V
Current Fed	25mA into V_{CC} *
NGATE Voltage	-0.3V to V_{CC}
V_{FB} , I_{TH} /RUN Voltages.....	-0.3V to 3.5V
SENSE Voltage	-0.3V to 1V
NGATE Peak Output Current (<10 μ s)	1A
Operating Junction Temperature Range (Notes 2, 3)	
LTC3803E, LTC3803I.....	-40°C to 125°C
LTC3803H	-40°C to 150°C
LTC3803MP	-55°C to 150°C
Storage Temperature Range.....	-65°C to 150°C
Lead Temperature (Soldering, 10 sec)	300°C

*LTC3803 internal clamp circuit self regulates V_{CC} voltage to 9.5V.

PIN CONFIGURATION

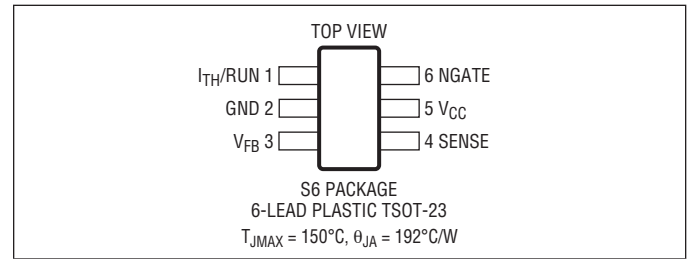

ORDER INFORMATION

LEAD FREE FINISH	TAPE AND REEL	PART MARKING*	PACKAGE DESCRIPTION	TEMPERATURE RANGE
LTC3803ES6#PBF	LTC3803ES6#TRPBF	LTACV	6-Lead Plastic TSOT-23	-40°C to 125°C
LTC3803IS6#PBF	LTC3803IS6#TRPBF	LTBNC	6-Lead Plastic TSOT-23	-40°C to 125°C
LTC3803HS6#PBF	LTC3803HS6#TRPBF	LTBNC	6-Lead Plastic TSOT-23	-40°C to 150°C
LTC3803MPS6#PBF	LTC3803MPS6#TRPBF	LTBNC	6-Lead Plastic TSOT-23	-55°C to 150°C
LEAD BASED FINISH	TAPE AND REEL	PART MARKING*	PACKAGE DESCRIPTION	TEMPERATURE RANGE
LTC3803ES6	LTC3803ES6#TR	LTACV	6-Lead Plastic TSOT-23	-40°C to 125°C
LTC3803IS6	LTC3803IS6#TR	LTBNC	6-Lead Plastic TSOT-23	-40°C to 125°C
LTC3803HS6	LTC3803HS6#TR	LTBNC	6-Lead Plastic TSOT-23	-40°C to 150°C
LTC3803MPS6	LTC3803MPS6#TR	LTBNC	6-Lead Plastic TSOT-23	-55°C to 150°C

Consult LTC Marketing for parts specified with wider operating temperature ranges. *The temperature grade is identified by a label on the shipping container.

For more information on lead free part marking, go to: <http://www.linear.com/leadfree/>

For more information on tape and reel specifications, go to: <http://www.linear.com/tapeandreel/>

ELECTRICAL CHARACTERISTICS

The ● denotes the specifications which apply over the full operating junction temperature range, otherwise specifications are at $T_A = 25^\circ\text{C}$. $V_{CC} = 8\text{V}$, unless otherwise noted. (Note 2)

SYMBOL	PARAMETER	CONDITIONS	MIN	TYP	MAX	UNITS
V_{TURNON}	V_{CC} Turn On Voltage	LTC3803E ●	7.8	8.7	9.2	V
		LTC3803H, LTC3803I ●	7.7	8.7	9.25	V
		LTC3803MP ●	7.6	8.7	9.5	V
$V_{TURNOFF}$	V_{CC} Turn Off Voltage	LTC3803E ●	4.6	5.7	6.8	V
		LTC3803H, LTC3803I ●	4	5.7	6.8	V
		LTC3803MP ●	4	5.7	7.25	V
V_{HYST}	V_{CC} Hysteresis	$V_{TURNON} - V_{TURNOFF}$ ●	1.5	3.0		V
		LTC3803E, LTC3803I, LTC3803H ●	1	3.0		V

3803fc

ELECTRICAL CHARACTERISTICS

The ● denotes the specifications which apply over the full operating junction temperature range, otherwise specifications are at $T_A = 25^\circ\text{C}$. $V_{CC} = 8\text{V}$, unless otherwise noted. (Note 2)

SYMBOL	PARAMETER	CONDITIONS	MIN	TYP	MAX	UNITS	
V_{CLAMP1mA}	V_{CC} Shunt Regulator Voltage at 1mA	$I_{\text{CC}} = 1\text{mA}$, $V_{\text{ITH/RUN}} = 0\text{V}$	●	8.3	9.4	10.3	V
		LTC3803E	●	8.3	9.4	10.5	V
		LTC3803H, LTC3803I	●	8	9.4	10.5	V
		LTC3803MP	●	8	9.4	10.5	V
$V_{\text{CLAMP25mA}}$	V_{CC} Shunt Regulator Voltage at 25mA	$I_{\text{CC}} = 25\text{mA}$, $V_{\text{ITH/RUN}} = 0\text{V}$	●	8.4	9.5	10.5	V
		LTC3803E	●	8.4	9.5	10.7	V
		LTC3803H, LTC3803I	●	8.1	9.5	10.7	V
		LTC3803MP	●	8.1	9.5	10.7	V
V_{MARGIN}	$V_{\text{CLAMP1mA}} - V_{\text{TURNON}}$ Margin	LTC3803E	●	0.05	0.6		V
		LTC3803H, LTC3803I, LTC3803MP	●	0.03	0.6		V
I_{CC}	Input DC Supply Current in Normal Operation	(Note 4) $V_{\text{ITH/RUN}} = 1.3\text{V}$		240	350	μA	
$I_{\text{CC(UV)}}$	Input DC Supply Current in Undervoltage	$V_{\text{CC}} = V_{\text{TURNON}} - 100\text{mV}$	●		40	90	μA
		LTC3803E LTC3803H, LTC3803I, LTC3803MP	●		40	110	μA
V_{ITHSHDN}	Shutdown Threshold (at $I_{\text{TH/RUN}}$)	$V_{\text{CC}} > V_{\text{TURNON}}$, $V_{\text{ITH/RUN}}$ Falling	●	0.15	0.28	0.45	V
		LTC3803E LTC3803H, LTC3803I, LTC3803MP	●	0.09	0.28	0.46	V
I_{THSTART}	Start-Up Current Source	$V_{\text{ITH/RUN}} = 0\text{V}$		0.2	0.3	0.4	μA
V_{FB}	Regulated Feedback Voltage	(Note 5)					
		LTC3803E:	●				
		$0^\circ\text{C} \leq T_J \leq 85^\circ\text{C}$		0.788	0.800	0.812	V
		$-40^\circ\text{C} \leq T_J \leq 85^\circ\text{C}$		0.780	0.800	0.816	V
		LTC3803I:	●				
		$0^\circ\text{C} \leq T_J \leq 85^\circ\text{C}$		0.788	0.800	0.812	V
		$-40^\circ\text{C} \leq T_J \leq 125^\circ\text{C}$		0.780	0.800	0.820	V
		LTC3803H:	●				
$0^\circ\text{C} \leq T_J \leq 85^\circ\text{C}$		0.788	0.800	0.812	V		
$-40^\circ\text{C} \leq T_J \leq 150^\circ\text{C}$		0.780	0.800	0.820	V		
LTC3803MP:	●						
$0^\circ\text{C} \leq T_J \leq 85^\circ\text{C}$		0.788	0.800	0.812	V		
$-55^\circ\text{C} \leq T_J \leq 150^\circ\text{C}$		0.780	0.800	0.820	V		
g_m	Error Amplifier Transconductance	$I_{\text{TH/RUN}}$ Pin Load = $\pm 5\mu\text{A}$ (Note 5)		200	333	500	$\mu\text{A/V}$
$\Delta V_{\text{O(LINE)}}$	Output Voltage Line Regulation	(Note 5)			0.05		mV/V
$\Delta V_{\text{O(LOAD)}}$	Output Voltage Load Regulation	$I_{\text{TH/RUN}}$ Sinking $5\mu\text{A}$ (Note 5)			3		mV/ μA
		$I_{\text{TH/RUN}}$ Sourcing $5\mu\text{A}$ (Note 5)			3		mV/ μA
I_{FB}	V_{FB} Input Current	(Note 5)			10	50	nA
f_{OSC}	Oscillator Frequency	$V_{\text{ITH/RUN}} = 1.3\text{V}$		180	200	240	kHz
$\text{DC}_{\text{ON(MIN)}}$	Minimum Switch On Duty Cycle	$V_{\text{ITH/RUN}} = 1.3\text{V}$, $V_{\text{FB}} = 0.8\text{V}$			6	8	%
$\text{DC}_{\text{ON(MAX)}}$	Maximum Switch On Duty Cycle	$V_{\text{ITH/RUN}} = 1.3\text{V}$, $V_{\text{FB}} = 0.8\text{V}$		70	80	90	%
t_{RISE}	Gate Drive Rise Time	$C_{\text{LOAD}} = 3000\text{pF}$			40		ns
t_{FALL}	Gate Drive Fall Time	$C_{\text{LOAD}} = 3000\text{pF}$ (Note 7)			40		ns
V_{IMAX}	Peak Current Sense Voltage	$R_{\text{SL}} = 0$ (Note 6)	●	90	100	115	mV
		LTC3803E	●	90	100	120	mV
		LTC3803H, LTC3803I	●	85	100	120	mV
		LTC3803MP	●	85	100	120	mV
I_{SLMAX}	Peak Slope Compensation Output Current	(Note 7)			5		μA
t_{SFST}	Soft-Start Time				1.4		ms

ELECTRICAL CHARACTERISTICS

Note 1: Stresses beyond those listed under Absolute Maximum Ratings may cause permanent damage to the device. Exposure to any Absolute Maximum Rating condition for extended periods may affect device reliability and lifetime.

Note 2: The LTC3803 is tested under pulsed load conditions such that $T_J \approx T_A$. The LTC3803E is guaranteed to meet specifications from 0°C to 85°C junction temperature. Specifications over the -40°C to 125°C operating junction temperature range are assured by design, characterization and correlation with statistical process controls. The LTC3803I is guaranteed to meet performance specifications over the -40°C to 125°C operating junction temperature range, the LTC3803H is guaranteed to meet performance specifications over the -40°C to 150°C operating junction temperature range and the LTC3803MP is tested and guaranteed over the full -55°C to 150°C operating junction temperature range. High junction temperatures degrade operating lifetimes; operating lifetime is derated for junction temperatures greater than 125°C. Note that the maximum ambient temperature consistent

with these specifications is determined by specific operating conditions in conjunction with board layout, the rated package thermal impedance and other environmental factors.

Note 3: T_J is calculated from the ambient temperature T_A and power dissipation P_D according to the following formula:

$$T_J = T_A + (P_D \cdot 230^\circ\text{C/W}).$$

Note 4: Dynamic supply current is higher due to the gate charge being delivered at the switching frequency.

Note 5: The LTC3803 is tested in a feedback loop that servos V_{FB} to the output of the error amplifier while maintaining I_{TH}/RUN at the midpoint of the current limit range.

Note 6: Peak current sense voltage is reduced dependent on duty cycle and an optional external resistor in series with the SENSE pin (R_{SL}). For details, refer to the programmable slope compensation feature in the Applications Information section.

Note 7: Guaranteed by design.

TYPICAL PERFORMANCE CHARACTERISTICS

Reference Voltage vs Temperature

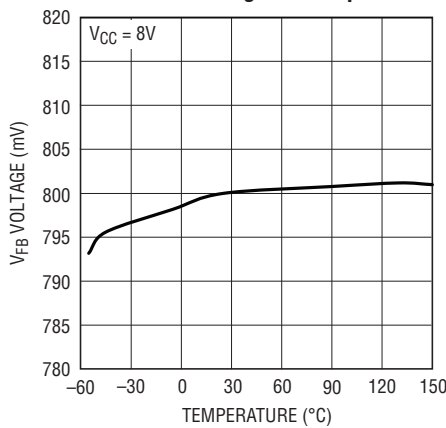

3803 G01

Reference Voltage vs Supply Voltage

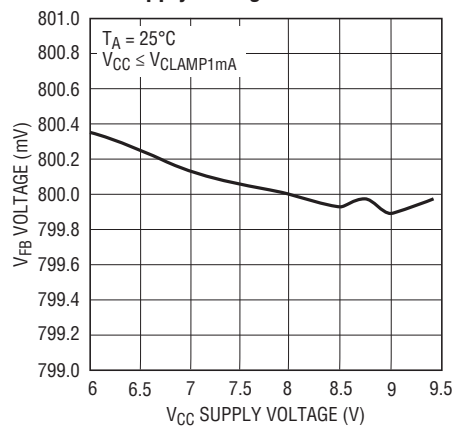

3803 F02

Reference Voltage vs V_{CC} Shunt Regulator Current

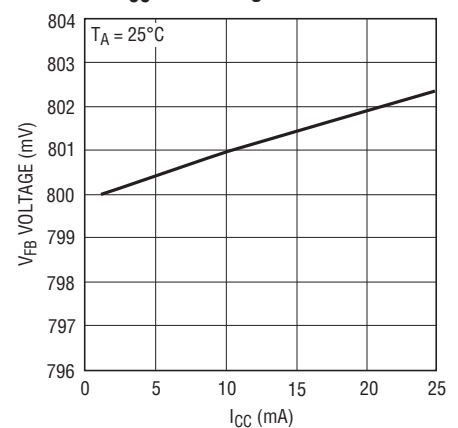

3803 G03

Oscillator Frequency vs Temperature

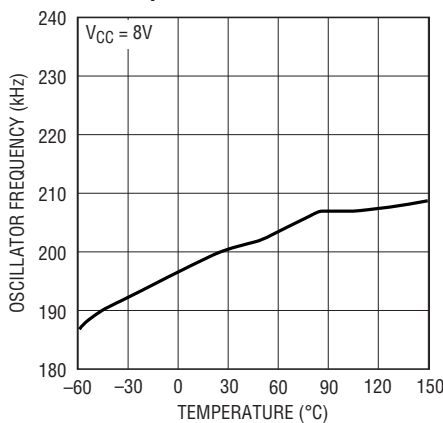

3803 G04

Oscillator Frequency vs Supply Voltage

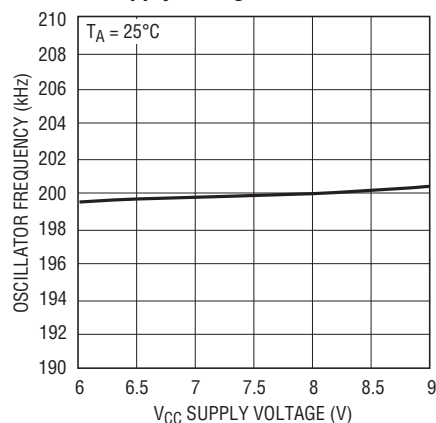

3803 G05

Oscillator Frequency vs V_{CC} Shunt Regulator Current

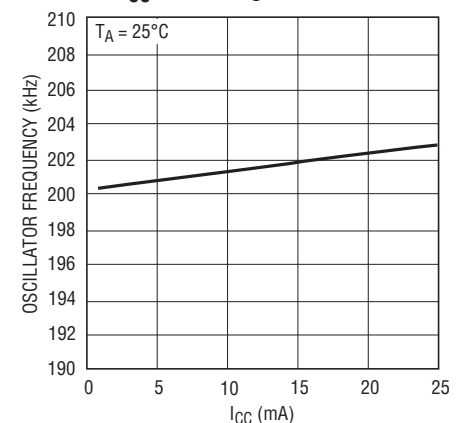

3803 G06

3803fc

TYPICAL PERFORMANCE CHARACTERISTICS

V_{CC} Undervoltage Lockout Thresholds vs Temperature

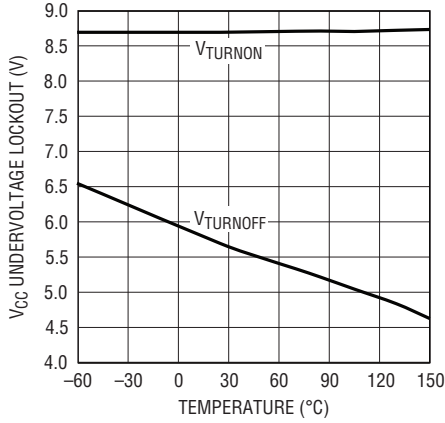

V_{CC} Shunt Regulator Voltage vs Temperature

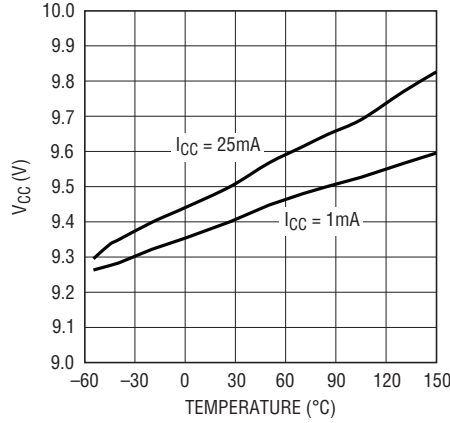

I_{CC} Supply Current vs Temperature

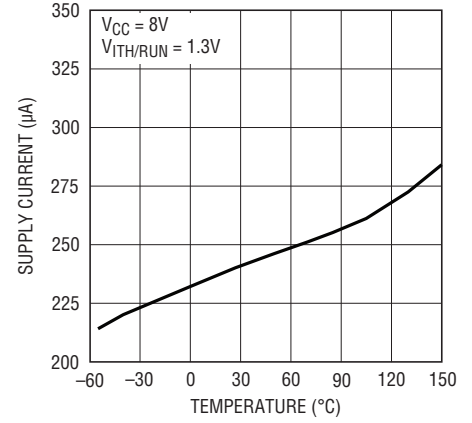

Start-Up I_{CC} Supply Current vs Temperature

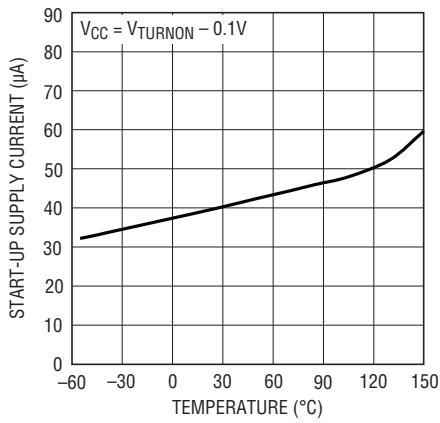

I_{TH}/RUN Shutdown Threshold vs Temperature

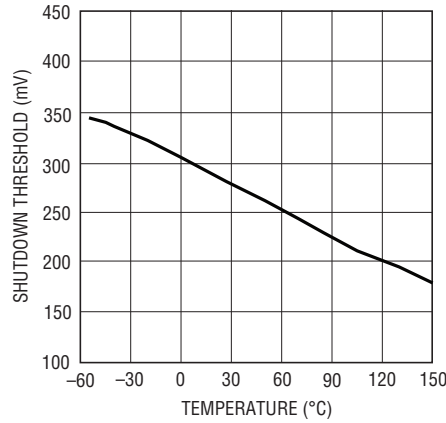

I_{TH}/RUN Start-Up Current Source vs Temperature

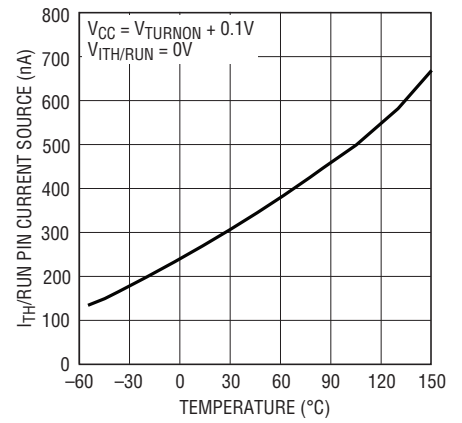

Peak Current Sense Voltage vs Temperature

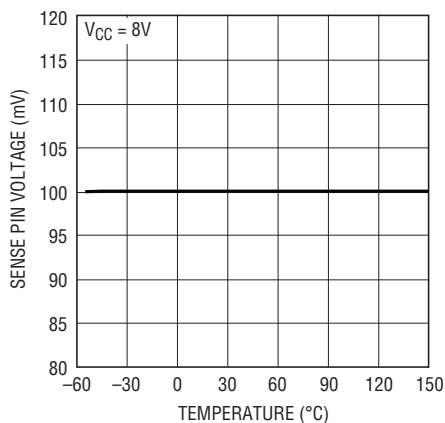

Soft-Start Time vs Temperature

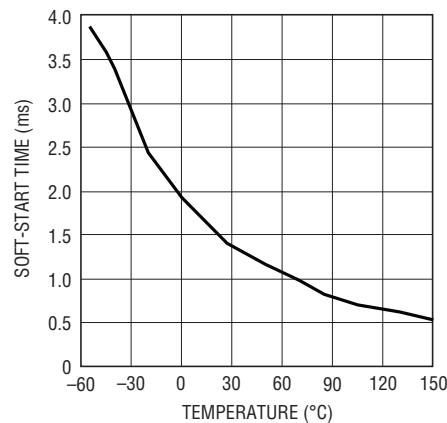

PIN FUNCTIONS

I_{TH}/RUN (Pin 1): This pin performs two functions. It serves as the error amplifier compensation point as well as the run/shutdown control input. Nominal voltage range is 0.7V to 1.9V. Forcing this pin below the shutdown threshold ($V_{ITHSHDN}$) causes the LTC3803 to shut down. In shutdown mode, the NGATE pin is held low.

GND (Pin 2): Ground Pin.

V_{FB} (Pin 3): Receives the feedback voltage from an external resistive divider across the output.

SENSE (Pin 4): This pin performs two functions. It monitors switch current by reading the voltage across an external current sense resistor to ground. It also injects a current ramp that develops slope compensation voltage across an optional external programming resistor.

V_{CC} (Pin 5): Supply Pin. Must be closely decoupled to GND (Pin 2).

NGATE (Pin 6): Gate Drive for the External N-Channel MOSFET. This pin swings from 0V to V_{CC}.

BLOCK DIAGRAM

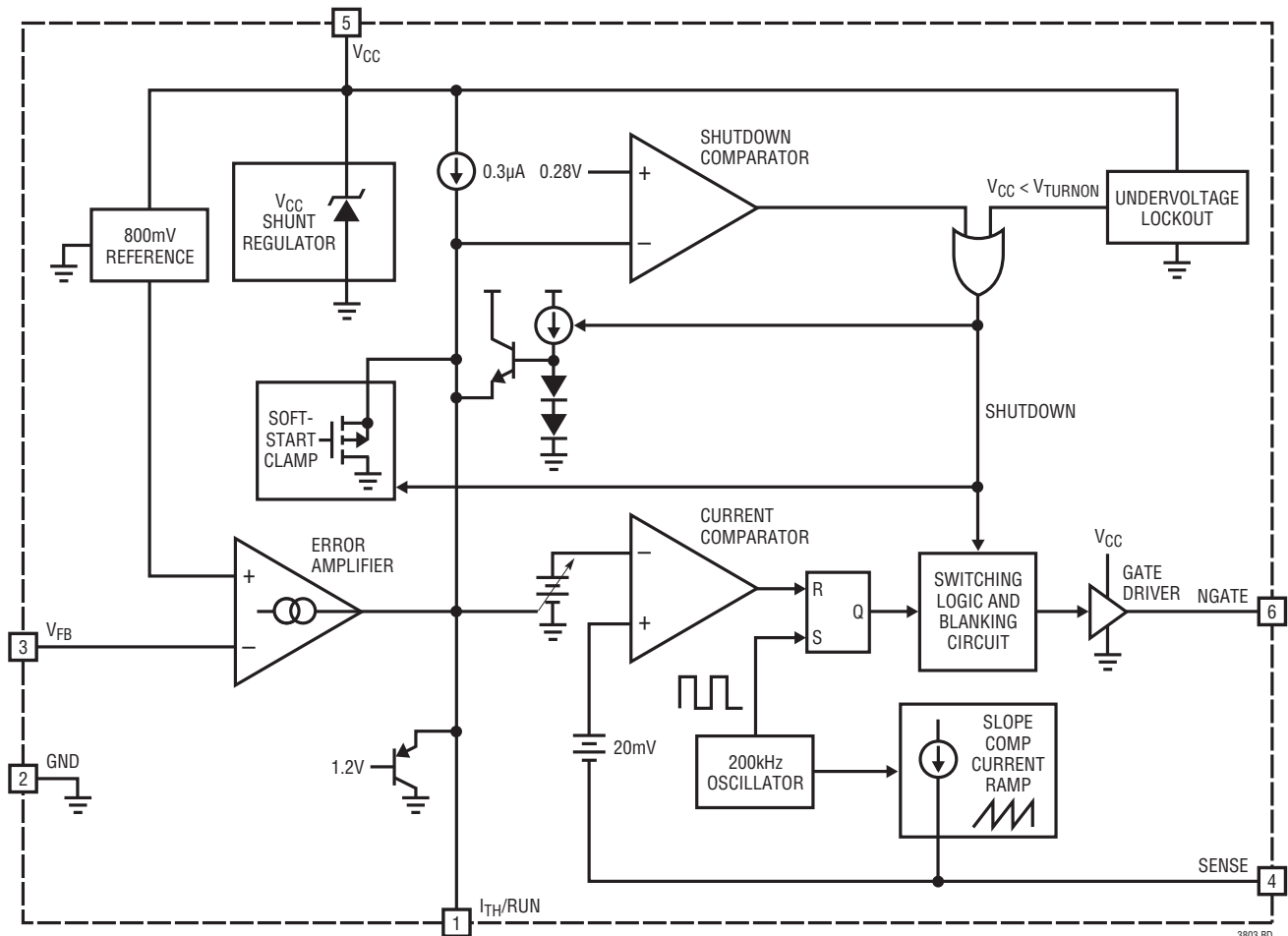

3803 BD

OPERATION

The LTC3803 is a constant frequency current mode controller for flyback and DC/DC boost converter applications in a tiny ThinSOT package. The LTC3803 is designed so that none of its pins need to come in contact with the input or output voltages of the power supply circuit of which it is a part, allowing the conversion of voltages well beyond the LTC3803's absolute maximum ratings.

Main Control Loop

Due to space limitations, the basics of current mode DC/DC conversion will not be discussed here; instead, the reader is referred to the detailed treatment in Application Note 19, or in texts such as Abraham Pressman's *Switching Power Supply Design*.

Please refer to the Block Diagram and the Typical Application on the front page of this data sheet. An external resistive voltage divider presents a fraction of the output voltage to the V_{FB} pin. The divider must be designed so that when the output is at the desired voltage, the V_{FB} pin voltage will equal the 800mV from the internal reference. If the load current increases, the output voltage will decrease slightly, causing the V_{FB} pin voltage to fall below 800mV. The error amplifier responds by feeding current into the I_{TH}/RUN pin. If the load current decreases, the V_{FB} voltage will rise above 800mV and the error amplifier will sink current away from the I_{TH}/RUN pin.

The voltage at the I_{TH}/RUN pin commands the pulse-width modulator formed by the oscillator, current comparator and RS latch. Specifically, the voltage at the I_{TH}/RUN pin sets the current comparator's trip threshold. The current comparator monitors the voltage across a current sense resistor in series with the source terminal of the external MOSFET. The LTC3803 turns on the external power MOSFET when the internal free-running 200kHz oscillator sets the RS latch. It turns off the MOSFET when the current comparator resets the latch or when 80% duty cycle is reached, whichever happens first. In this way, the peak current levels through the flyback transformer's primary and secondary are controlled by the I_{TH}/RUN voltage.

Since the I_{TH}/RUN voltage is increased by the error amplifier whenever the output voltage is below nominal, and decreased whenever output voltage exceeds nominal, the

voltage regulation loop is closed. For example, whenever the load current increases, output voltage will decrease slightly, and sensing this, the error amplifier raises the I_{TH}/RUN voltage by sourcing current into the I_{TH}/RUN pin, raising the current comparator threshold, thus increasing the peak currents through the transformer primary and secondary. This delivers more current to the load, bringing the output voltage back up.

The I_{TH}/RUN pin serves as the compensation point for the control loop. Typically, an external series RC network is connected from I_{TH}/RUN to ground and is chosen for optimal response to load and line transients. The impedance of this RC network converts the output *current* of the error amplifier to the I_{TH}/RUN *voltage* which sets the current comparator threshold and commands considerable influence over the dynamics of the voltage regulation loop.

Start-Up/Shutdown

The LTC3803 has two shutdown mechanisms to disable and enable operation: an undervoltage lockout on the V_{CC} supply pin voltage, and a forced shutdown whenever external circuitry drives the I_{TH}/RUN pin low. The LTC3803 transitions into and out of shutdown according to the state diagram (Figure 1).

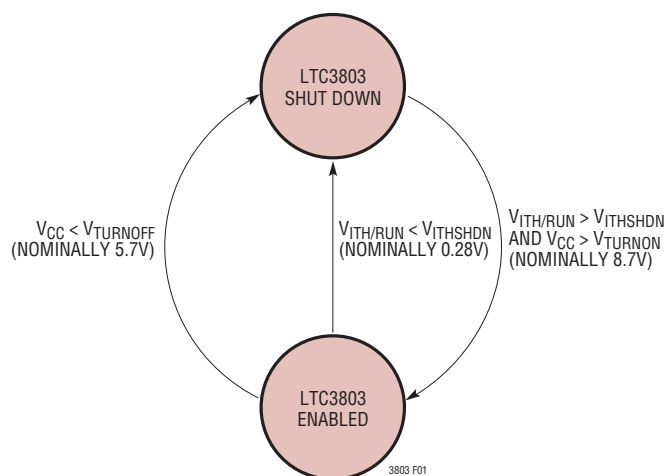

Figure 1. Start-Up/Shutdown State Diagram

OPERATION

The undervoltage lockout (UVLO) mechanism prevents the LTC3803 from trying to drive a MOSFET with insufficient V_{GS} . The voltage at the V_{CC} pin must exceed V_{TURNON} (nominally 8.7V) at least momentarily to enable LTC3803 operation. The V_{CC} voltage is then allowed to fall to $V_{TURNOFF}$ (nominally 5.7V) before undervoltage lockout disables the LTC3803. This wide UVLO hysteresis range supports the use of a bias winding on the flyback transformer to power the LTC3803—see the section Powering the LTC3803.

The I_{TH}/RUN pin can be driven below $V_{ITHSHDN}$ (nominally 0.28V) to force the LTC3803 into shutdown. An internal 0.3 μ A current source always tries to pull this pin towards V_{CC} . When the I_{TH}/RUN pin voltage is allowed to exceed $V_{ITHSHDN}$, and V_{CC} exceeds V_{TURNON} , the LTC3803 begins to operate and an internal clamp immediately pulls the I_{TH}/RUN pin up to about 0.7V. In operation, the I_{TH}/RUN pin voltage will vary from roughly 0.7V to 1.9V to represent current comparator thresholds from zero to maximum.

Internal Soft-Start

An internal soft-start feature is enabled whenever the LTC3803 comes out of shutdown. Specifically, the I_{TH}/RUN voltage is clamped and is prevented from reaching maximum until roughly 1.4ms has passed. This allows the input and output currents of LTC3803-based power supplies to rise in a smooth and controlled manner on start-up.

Powering the LTC3803

In the simplest case, the LTC3803 can be powered from a high voltage supply through a resistor. A built-in shunt regulator from the V_{CC} pin to GND will draw as much current as needed through this resistor to regulate the V_{CC} voltage to around 9.5V as long as the V_{CC} pin is not forced to sink more than 25mA. This shunt regulator is always active, even when the LTC3803 is in shutdown, since it serves the vital function of protecting the V_{CC} pin from seeing too much voltage.

For higher efficiency or for wide V_{IN} range applications, flyback controllers are typically powered through a separate bias winding on the flyback transformer. The LTC3803 has the wide UVLO hysteresis and small V_{CC} supply current draw that is needed to support such bootstrapped hysteretic start-up schemes.

The V_{CC} pin must be bypassed to ground immediately adjacent to the IC pins with a minimum of a 10 μ F ceramic or tantalum capacitor. Proper supply bypassing is necessary to supply the high transient currents required by the MOSFET gate driver.

Adjustable Slope Compensation

The LTC3803 injects a 5 μ A peak current ramp out through its SENSE pin which can be used for slope compensation in designs that require it. This current ramp is approximately linear and begins at zero current at 6% duty cycle, reaching peak current at 80% duty cycle. Additional details are provided in the Applications Information section.

APPLICATIONS INFORMATION

Many LTC3803 application circuits can be derived from the topology shown in Figure 2.

The LTC3803 itself imposes no limits on allowed power output, input voltage V_{IN} or desired regulated output voltage V_{OUT} ; these are all determined by the ratings on the external power components. The key factors are: Q1's maximum drain-source voltage (BV_{DSS}), on-resistance ($R_{DS(ON)}$) and maximum drain current, T1's saturation flux level and winding insulation breakdown voltages, C_{IN} and C_{OUT} 's maximum working voltage, ESR, and maximum ripple current ratings, and D1 and R_{SENSE} 's power ratings.

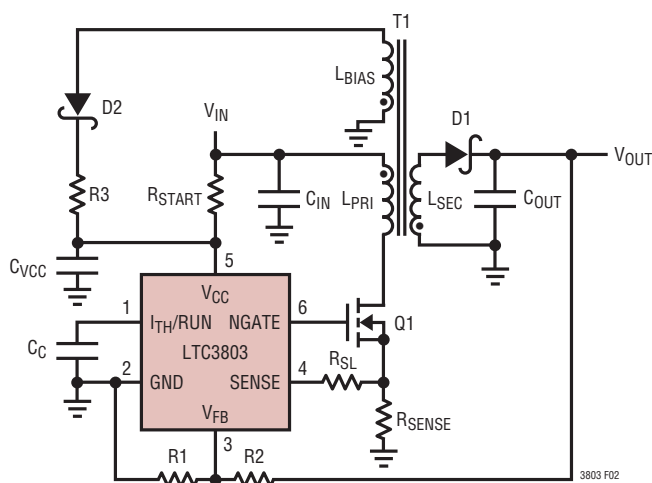

Figure 2. Typical LTC3803 Application Circuit

SELECTING FEEDBACK RESISTOR DIVIDER VALUES

The regulated output voltage is determined by the resistor divider across V_{OUT} ($R1$ and $R2$ in Figure 2). The ratio of $R2$ to $R1$ needed to produce a desired V_{OUT} can be calculated:

$$R2 = \frac{V_{OUT} - 0.8V}{0.8V} \cdot R1$$

Choose resistance values for $R1$ and $R2$ to be as large as possible in order to minimize any efficiency loss due to the static current drawn from V_{OUT} , but just small enough so that when V_{OUT} is in regulation, the error caused by the nonzero input current to the V_{FB} pin is less than 1%. A good rule of thumb is to choose $R1$ to be 80k or less.

TRANSFORMER DESIGN CONSIDERATIONS

Transformer specification and design is perhaps the most critical part of applying the LTC3803 successfully. In addition to the usual list of caveats dealing with high frequency power transformer design, the following should prove useful.

Turns Ratios

Due to the use of the external feedback resistor divider ratio to set output voltage, the user has relative freedom in selecting transformer turns ratio to suit a given application. Simple ratios of small integers, e.g., 1:1, 2:1, 3:2, etc. can be employed which yield more freedom in setting total turns and mutual inductance. Simple integer turns ratios also facilitate the use of “off-the-shelf” configurable transformers such as the Coiltronics VERSA-PAC™ series in applications with high input to output voltage ratios. For example, if a 6-winding VERSA-PAC is used with three windings in series on the primary and three windings in parallel on the secondary, a 3:1 turns ratio will be achieved.

Turns ratio can be chosen on the basis of desired duty cycle. However, remember that the input supply voltage plus the secondary-to-primary referred version of the flyback pulse (including leakage spike) must not exceed the allowed external MOSFET breakdown rating.

Leakage Inductance

Transformer leakage inductance (on either the primary or secondary) causes a voltage spike to occur after the output switch (Q1) turn-off. This is increasingly prominent at higher load currents, where more stored energy must be dissipated. In some cases a “snubber” circuit will be required to avoid overvoltage breakdown at the MOSFET's drain node. Application Note 19 is a good reference on snubber design.

A bifilar or similar winding technique is a good way to minimize troublesome leakage inductances. However, remember that this will limit the primary-to-secondary breakdown voltage, so bifilar winding is not always practical.

APPLICATIONS INFORMATION

CURRENT SENSE RESISTOR CONSIDERATIONS

The external current sense resistor (R_{SENSE} in Figure 2) allows the user to optimize the current limit behavior for the particular application. As the current sense resistor is varied from several ohms down to tens of milliohms, peak switch current goes from a fraction of an ampere to several amperes. Care must be taken to ensure proper circuit operation, especially with small current sense resistor values.

For example, a peak switch current of 5A requires a sense resistor of 0.020Ω . Note that the instantaneous peak power in the sense resistor is $0.5W$ and it must be rated accordingly. The LTC3803 has only a single sense line to this resistor. Therefore, any parasitic resistance in the ground side connection of the sense resistor will increase its apparent value. In the case of a 0.020Ω sense resistor, *one milliohm* of parasitic resistance will cause a 5% reduction in peak switch current. So the resistance of printed circuit copper traces and vias cannot necessarily be ignored.

PROGRAMMABLE SLOPE COMPENSATION

The LTC3803 injects a ramping current through its SENSE pin into an external slope compensation resistor (R_{SL} in Figure 2). This current ramp starts at zero right after the NGATE pin has been high for the LTC3803's minimum duty cycle of 6%. The current rises linearly towards a peak of $5\mu\text{A}$ at the maximum duty cycle of 80%, shutting off once the NGATE pin goes low. A series resistor (R_{SL}) connecting the SENSE pin to the current sense resistor (R_{SENSE}) thus develops a ramping voltage drop. From the perspective of the SENSE pin, this ramping voltage adds to the voltage across the sense resistor, effectively reducing the current comparator threshold in proportion to duty cycle. This stabilizes the control loop against subharmonic oscillation. The amount of reduction in the current comparator threshold (ΔV_{SENSE}) can be calculated using the following equation:

$$\Delta V_{\text{SENSE}} = \frac{\text{Duty Cycle} - 6\%}{74\%} \cdot 5\mu\text{A} \cdot R_{\text{SL}}$$

Note: LTC3803 enforces $6\% < \text{Duty Cycle} < 80\%$.

A good starting value for R_{SL} is $5.9k$, which gives a 30mV drop in current comparator threshold at 80% duty cycle. Designs not needing slope compensation may replace R_{SL} with a short circuit.

INTERNAL WIDE HYSTERESIS UNDERVOLTAGE LOCKOUT

The LTC3803 is designed to implement DC/DC converters operating from input voltages of typically 48V or more. The standard operating topology employs a third transformer winding (L_{BIAS} in Figure 2) on the primary side that provides power for the LTC3803 via its V_{CC} pin. However, this arrangement is not inherently self-starting. Start-up is affected by the use of an external "trickle-charge" resistor (R_{START} in Figure 2) and the presence of an internal wide hysteresis undervoltage lockout circuit that monitors V_{CC} pin voltage. Operation is as follows:

"Trickle charge" resistor R_{START} is connected to V_{IN} and supplies a small current, typically on the order of $100\mu\text{A}$ to $120\mu\text{A}$, to charge C_{VCC} . After some time, the voltage on C_{VCC} reaches the V_{CC} turn-on threshold. The LTC3803 then turns on abruptly and draws its normal supply current. The NGATE pin begins switching and the external MOSFET (Q1) begins to deliver power. The voltage on C_{VCC} begins to decline as the LTC3803 draws its normal supply current, which exceeds that delivered by R_{START} . After some time, typically tens of milliseconds, the output voltage approaches its desired value. By this time, the third transformer winding is providing virtually all the supply current required by the LTC3803.

One potential design pitfall is undersizing the value of capacitor C_{VCC} . In this case, the normal supply current drawn by the LTC3803 will discharge C_{VCC} too rapidly; before the third winding drive becomes effective, the V_{CC} turn-off threshold will be reached. The LTC3803 turns off,

APPLICATIONS INFORMATION

and the V_{CC} node begins to charge via R_{START} back up to the V_{CC} turn-on threshold. Depending on the particular situation, this may result in either several on-off cycles before proper operation is reached or permanent relaxation oscillation at the V_{CC} node.

Component selection is as follows:

Resistor R_{START} should be made small enough to yield a worst-case minimum charging current greater than the maximum rated LTC3803 start-up current, to ensure there is enough current to charge C_{VCC} to the V_{CC} turn-on threshold. It should be made large enough to yield a worst-case maximum charging current less than the minimum rated LTC3803 supply current, so that in operation, most of the LTC3803's supply current is delivered through the third winding. This results in the highest possible efficiency.

Capacitor C_{VCC} should then be made large enough to avoid the relaxation oscillation behavior described above. This is complicated to determine theoretically as it depends on the particulars of the secondary circuit and load behavior. Empirical testing is recommended.

The third transformer winding should be designed so that its output voltage, after accounting for the D2's forward voltage drop, exceeds the maximum V_{CC} turn-off threshold. Also, the third winding's nominal output voltage should be at least 0.5V below the minimum rated V_{CC} clamp voltage to avoid running up against the LTC3803's V_{CC} shunt regulator, needlessly wasting power.

V_{CC} SHUNT REGULATOR

In applications including a third transformer winding, the internal V_{CC} shunt regulator serves to protect the LTC3803 from overvoltage transients as the third winding is powering up.

In applications where a third transformer winding is undesirable or unavailable, the shunt regulator allows the LTC3803 to be powered through a single dropping resistor from V_{IN} to V_{CC} , in conjunction with a bypass capacitor, C_{VCC} , that closely decouples V_{CC} to GND (see Figure 3). This simplicity comes at the expense of reduced efficiency due to the static power dissipation in the R_{VCC} dropping resistor.

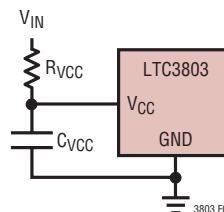

Figure 3. Powering the LTC3803 Via the Internal Shunt Regulator

The shunt regulator can draw up to 25mA through the V_{CC} pin to GND to drop enough voltage across R_{VCC} to regulate V_{CC} to around 9.5V. For applications where V_{IN} is low enough such that the static power dissipation in R_{VCC} is acceptable, using the V_{CC} shunt regulator is the simplest way to power the LTC3803.

EXTERNAL PREREGULATOR

The circuit in Figure 4 shows a third way to power the LTC3803. An external series preregulator consisting of series pass transistor Q1, Zener diode D1, and bias resistor R_B brings V_{CC} to at least 7.6V nominal, well above the maximum rated V_{CC} turn-off threshold. Resistor R_{START} momentarily charges the V_{CC} node up to the V_{CC} turn-on threshold, enabling the LTC3803.

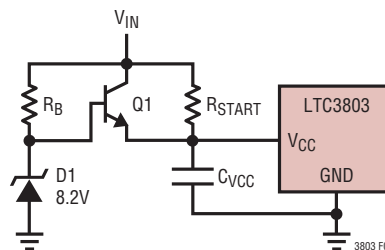
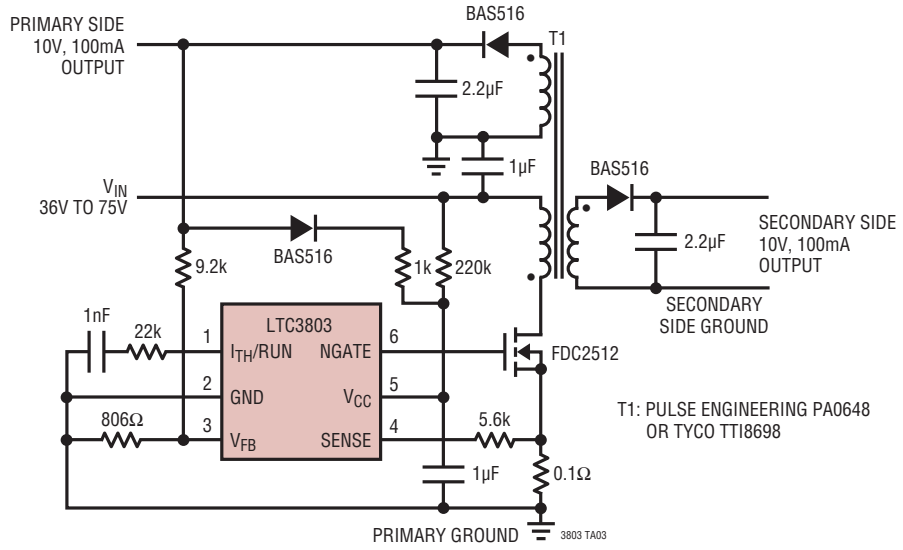

Figure 4. Powering the LTC3803 with an External Preregulator

TYPICAL APPLICATIONS

2W Isolated Housekeeping Telecom Converter



TYPICAL APPLICATIONS

4:1 Input Range 3.3V Output Isolated Flyback DC/DC Converter

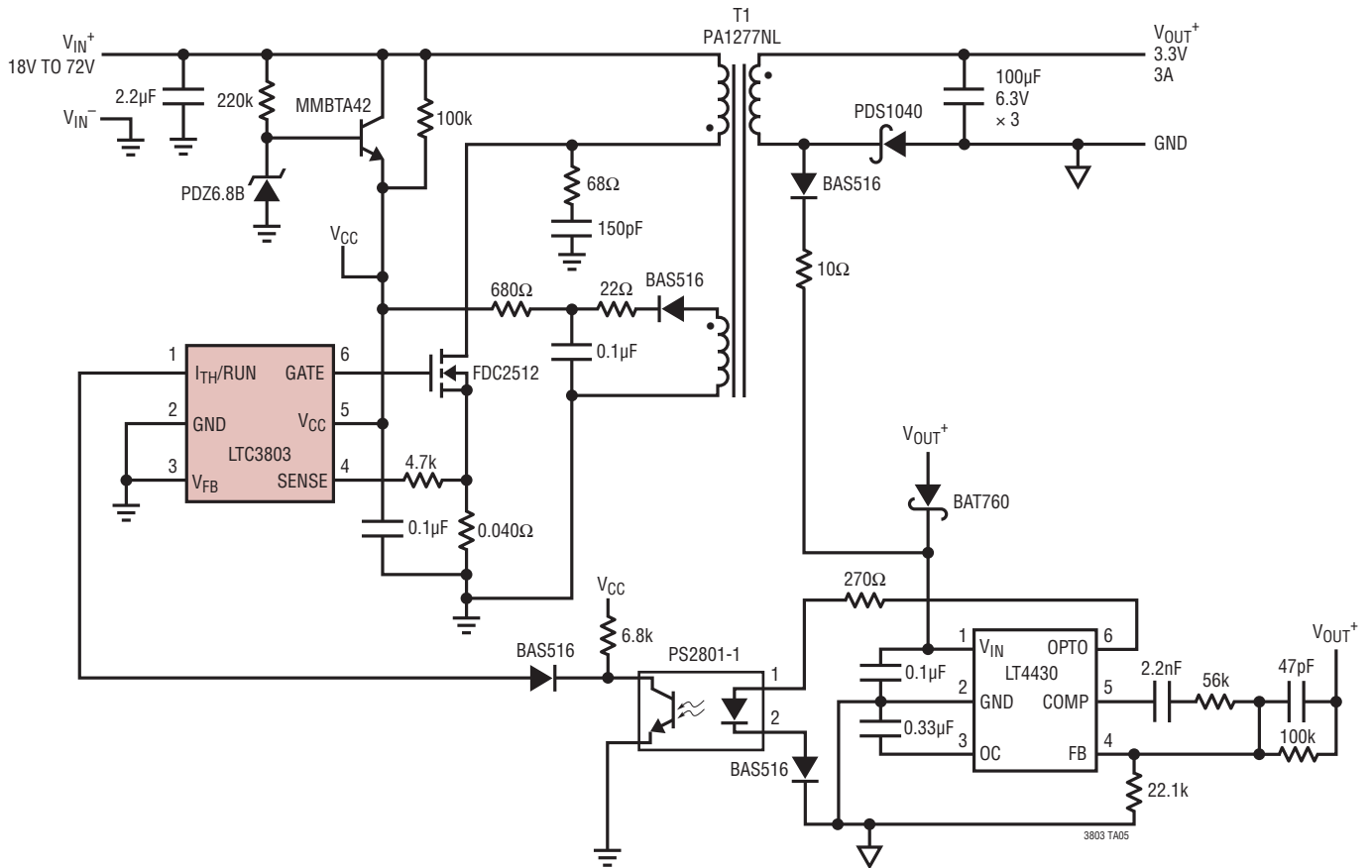

Efficiency vs Load Current

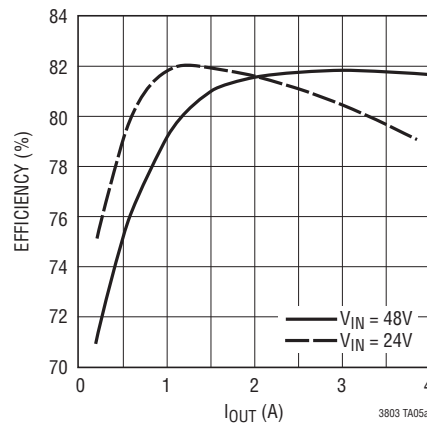

PACKAGE DESCRIPTION

S6 Package
6-Lead Plastic TSOT-23
 (Reference LTC DWG # 05-08-1636)

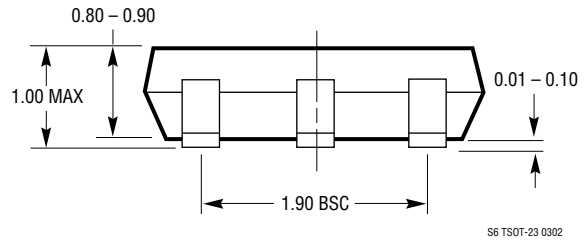
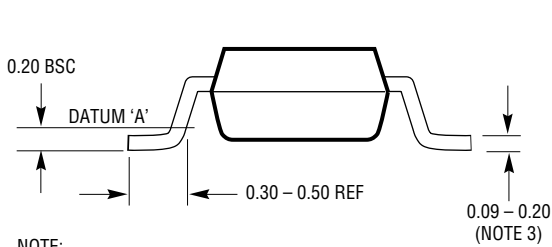
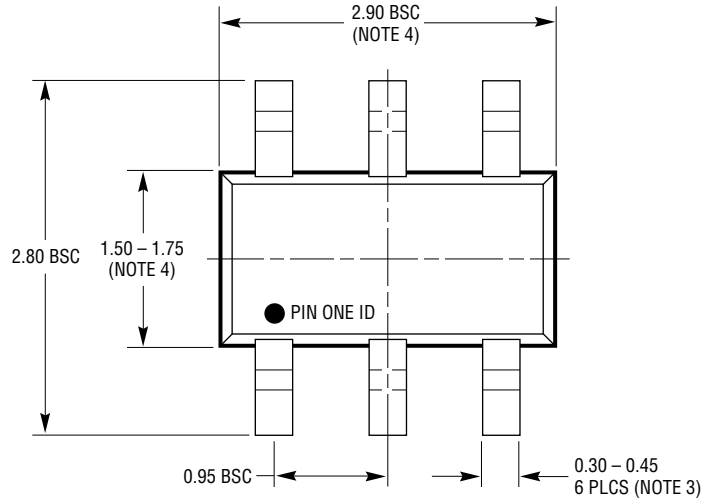
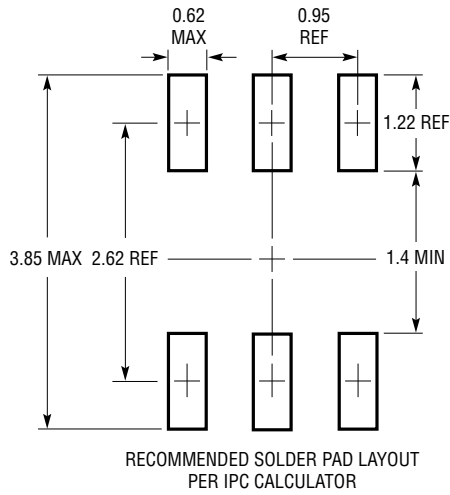

- NOTE:
1. DIMENSIONS ARE IN MILLIMETERS
 2. DRAWING NOT TO SCALE
 3. DIMENSIONS ARE INCLUSIVE OF PLATING
 4. DIMENSIONS ARE EXCLUSIVE OF MOLD FLASH AND METAL BURR
 5. MOLD FLASH SHALL NOT EXCEED 0.254mm
 6. JEDEC PACKAGE REFERENCE IS MO-193

REVISION HISTORY (Revision history begins at Rev C)

REV	DATE	DESCRIPTION	PAGE NUMBER
C	6/10	MP-grade part added. Reflected throughout the data sheet.	1 to 16

TYPICAL APPLICATIONS

90% Efficient Synchronous Flyback Converter

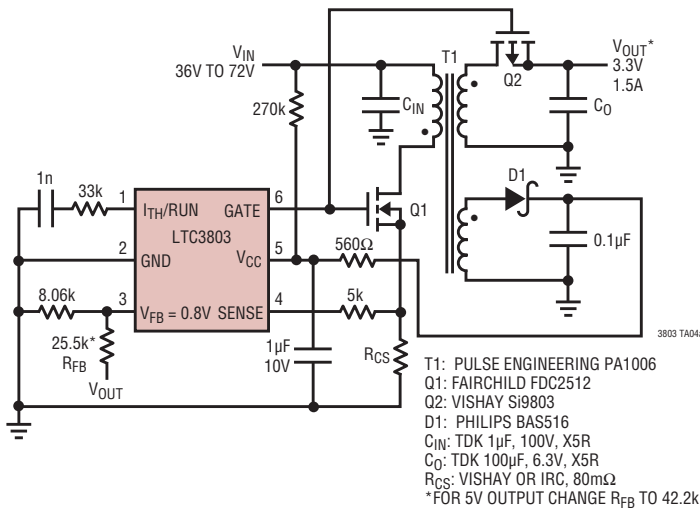

Synchronous Flyback 3.3V_{OUT}

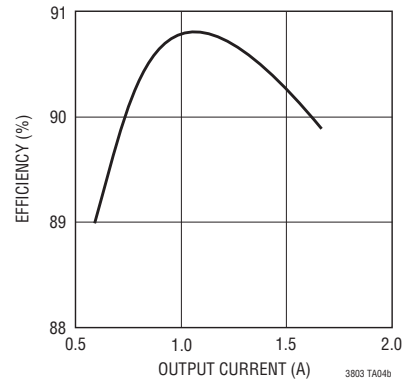

Synchronous Flyback 5V_{OUT}

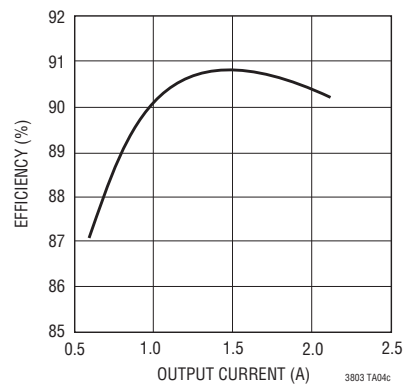

RELATED PARTS

PART NUMBER	DESCRIPTION	COMMENTS
LT3573	Isolated Flyback Switching Regulator with 60V Integrated Switch	$3V \leq V_{IN} \leq 40V$, No Opto-Isolator or Third Winding Required, Up to 7W Output Power, MSOP-16E
LTC3805/ LTC3805-5	Adjustable Constant Frequency Flyback, Boost, SEPIC DC/DC Controller	V_{IN} and V_{OUT} Limited Only by External Components, 3mm × 3mm DFN-10, MSOP-10E Packages
LTC3873/ LTC3873-5	No R _{SENSE} [™] Constant Frequency Flyback, Boost, SEPIC Controller	V_{IN} and V_{OUT} Limited Only by External Components, 8-pin ThinSOT or 2mm × 3mm DFN-8 Packages
LT3757	Boost, Flyback, SEPIC and Inverting Controller	$2.9V \leq V_{IN} \leq 40V$, 100kHz to 1MHz Programmable Operating Frequency, 3mm × 3mm DFN-10 and MSOP-10E Package
LT3758	Boost, Flyback, SEPIC and Inverting Controller	$5.5V \leq V_{IN} \leq 100V$, 100kHz to 1MHz Programmable Operating Frequency, 3mm × 3mm DFN-10 and MSOP-10E
LTC1871/LTC1871-1/ LTC1871-7	Wide Input Range, No R _{SENSE} Low Quiescent Current Flyback, Boost and SEPIC Controller	Programmable Operating Frequency, $2.5V \leq V_{IN} \leq 36V$, Burst Mode [®] Operation at Light Load, MSOP-10

Looking for pricing, stock, or lifecycle information?

Click below to explore more details on WIN SOURCE:

 [View LTC3803IS6#TRMPBF on WIN SOURCE](#)

 [Linear Technology](#) Information

Optimize Your Supply Chain with WIN SOURCE Solutions

-  Global Sourcing Solution
-  Obsolete Management
-  Cost Control Management
-  Shortage Management
-  Alternative Solution
-  Excess Inventory Management