



**THE DATASHEET OF  
LTC3803IS6-5#TRMPBF**



# Constant Frequency Current Mode Flyback DC/DC Controller in ThinSOT

## FEATURES

- $V_{IN}$  and  $V_{OUT}$  Limited Only by External Components
- 4.8V Undervoltage Lockout Threshold
- Operating Junction Temperature from  $-55^{\circ}\text{C}$  to  $150^{\circ}\text{C}$
- Adjustable Slope Compensation
- Internal Soft-Start
- Constant Frequency 200kHz Operation
- $\pm 1.5\%$  Reference Accuracy
- Current Mode Operation for Excellent Line and Load Transient Response
- No Minimum Load Requirement
- Low Quiescent Current: 240 $\mu\text{A}$
- Low Profile (1mm) SOT-23 Package

## APPLICATIONS

- 42V and 12V Automotive Power Supplies
- Telecom Power Supplies
- Auxiliary/Housekeeping Power Supplies
- Power Over Ethernet

LT, LTC, LTM, Burst Mode, Linear Technology and the Linear logo are registered trademarks and ThinSOT and No R<sub>SENSE</sub> are trademarks of Linear Technology Corporation. All other trademarks are the property of their respective owners.

## DESCRIPTION

The LTC<sup>®</sup>3803-5 is a constant frequency current mode flyback controller optimized for driving N-channel MOSFETs in high input voltage applications. The LTC3803-5 operates from inputs as low as 5V. Constant frequency operation is maintained down to very light loads, resulting in less low frequency noise generation over a wide range of load currents. Slope compensation can be programmed with an external resistor.

The LTC3803-5 provides  $\pm 1.5\%$  output voltage accuracy and consumes only 240 $\mu\text{A}$  of quiescent current. Ground-referenced current sensing allows LTC3803-5-based converters to accept input supplies beyond the LTC3803-5's absolute maximum  $V_{CC}$ . For simplicity, the LTC3803-5 can be powered from a high  $V_{IN}$  through a resistor, due to its internal shunt regulator. An internal undervoltage lockout shuts down the IC when the input voltage is too low to provide sufficient gate drive to the external MOSFET.

The LTC3803-5 is available in a low profile (1mm) 6-lead SOT-23 (ThinSOT™) package.

## TYPICAL APPLICATION

Dual Output Wide Input Range Converter

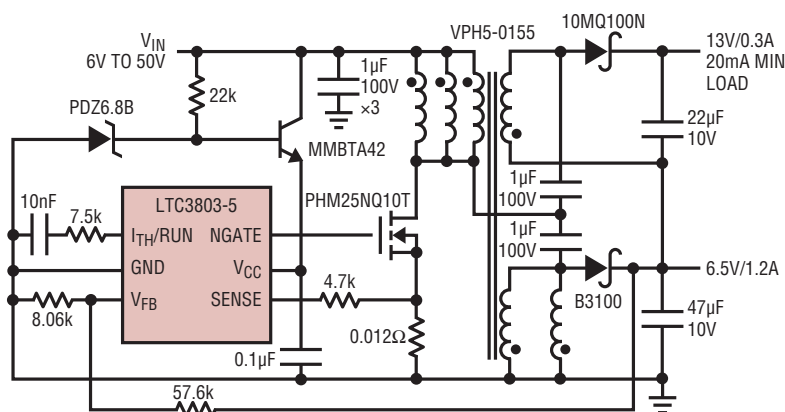

ALL CAPACITORS ARE X7R, TDK

38035 TA01

Efficiency and Power Loss  
vs Output Power

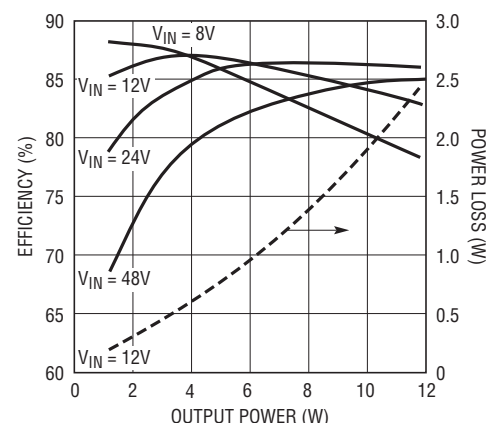

38035 TA01b

38035fd

# LTC3803-5

## ABSOLUTE MAXIMUM RATINGS

(Note 1)

$V_{CC}$ to GND (Current Fed) .....	25mA into $V_{CC}$ *
NGATE Voltage .....	-0.3V to $V_{CC}$
$V_{FB}$ , $I_{TH}$ /RUN Voltages.....	-0.3V to 3.5V
SENSE Voltage .....	-0.3V to 1V
NGATE Peak Output Current (<10 $\mu$ s) .....	1A
Operating Junction Temperature Range (Notes 2, 3)	
LTC3803E-5 .....	-40°C to 125°C
LTC3803I-5 .....	-40°C to 125°C
LTC3803H-5 (Note 3).....	-40°C to 150°C
LTC3803MP-5 (Note 3).....	-55°C to 150°C
Storage Temperature Range.....	-65°C to 150°C
Lead Temperature (Soldering, 10 sec) .....	300°C

\*LTC3803-5 internal clamp circuit self regulates  $V_{CC}$  voltage to 8.1V.

## PIN CONFIGURATION

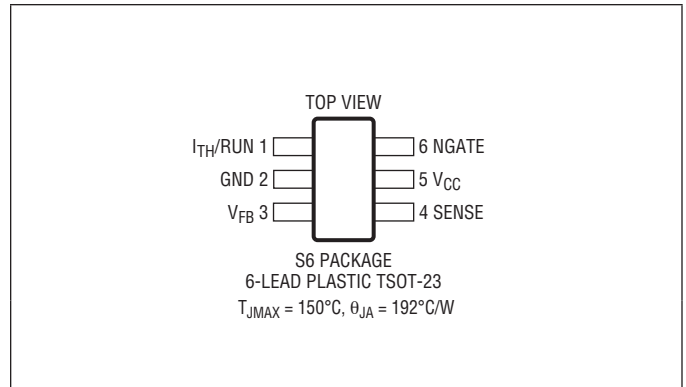

## ORDER INFORMATION

LEAD FREE FINISH	TAPE AND REEL	PART MARKING*	PACKAGE DESCRIPTION	TEMPERATURE RANGE
LTC3803ES6-5#PBF	LTC3803ES6-5#TRPBF	LTBPF	6-Lead Low Profile (1mm) SOT-23	-40°C to 125°C
LTC3803IS6-5#PBF	LTC3803IS6-5#TRPBF	LTBMH	6-Lead Low Profile (1mm) SOT-23	-40°C to 125°C
LTC3803HS6-5#PBF	LTC3803HS6-5#TRPBF	LTBMH	6-Lead Low Profile (1mm) SOT-23	-40°C to 150°C
LTC3803MPS6-5#PBF	LTC3803MPS6-5#TRPBF	LTBMH	6-Lead Low Profile (1mm) SOT-23	-55°C to 150°C
LEAD BASED FINISH	TAPE AND REEL	PART MARKING*	PACKAGE DESCRIPTION	TEMPERATURE RANGE
LTC3803ES6-5	LTC3803ES6-5#TR	LTBPF	6-Lead Low Profile (1mm) SOT-23	-40°C to 125°C
LTC3803IS6-5	LTC3803IS6-5#TR	LTBMH	6-Lead Low Profile (1mm) SOT-23	-40°C to 125°C
LTC3803HS6-5	LTC3803HS6-5#TR	LTBMH	6-Lead Low Profile (1mm) SOT-23	-40°C to 150°C
LTC3803MPS6-5	LTC3803MPS6-5#TR	LTBMH	6-Lead Low Profile (1mm) SOT-23	-55°C to 150°C

Consult LTC Marketing for parts specified with wider operating temperature ranges. \*The temperature grade is identified by a label on the shipping container.

For more information on lead free part marking, go to: <http://www.linear.com/leadfree/>

For more information on tape and reel specifications, go to: <http://www.linear.com/tapeandreeel/>

## ELECTRICAL CHARACTERISTICS

The ● denotes the specifications which apply over the full operating junction temperature range, otherwise specifications are at  $T_A = 25^\circ\text{C}$ .  $V_{CC} = 5\text{V}$ , unless otherwise noted. (Notes 2, 3)

SYMBOL	PARAMETER	CONDITIONS	MIN	TYP	MAX	UNITS
$V_{TURNON}$	$V_{CC}$ Turn On Voltage	LTC3803E-5 ● LTC3803I-5, LTC3803H-5, LTC3803MP-5 ●	4 3.9	4.8 4.8	5.7 5.7	V V
$V_{TURNOFF}$	$V_{CC}$ Turn Off Voltage	LTC3803E-5 ● LTC3803I-5, LTC3803H-5, LTC3803MP-5 ●	3.3 3.2	4 4	4.9 4.9	V V
$V_{HYST}$	$V_{CC}$ Hysteresis	$V_{TURNON} - V_{TURNOFF}$ ●	0.05	0.8		V
$V_{CLAMP1mA}$	$V_{CC}$ Shunt Regulator Voltage at 1mA	$I_{CC} = 1\text{mA}$ , $V_{ITH/RUN} = 0\text{V}$ LTC3803E-5 ● LTC3803I-5, LTC3803H-5 ● LTC3803MP-5 ●	6.2 6.2 5.9	8 8 8	9.9 10.4 10.4	V V V

38035fd

## ELECTRICAL CHARACTERISTICS

The ● denotes the specifications which apply over the full operating junction temperature range, otherwise specifications are at  $T_A = 25^\circ\text{C}$ .  $V_{CC} = 5\text{V}$ , unless otherwise noted. (Notes 2, 3)

SYMBOL	PARAMETER	CONDITIONS	MIN	TYP	MAX	UNITS
$V_{\text{CLAMP}25\text{mA}}$	$V_{\text{CC}}$ Shunt Regulator Voltage at 25mA	$I_{\text{CC}} = 25\text{mA}$ , $V_{\text{ITH/RUN}} = 0\text{V}$ LTC3803E-5 ● LTC3803I-5, LTC3803H-5 ● LTC3803MP-5 ●	6.3 6.3 6	8.1 8.1 8.1	10.3 10.7 10.7	V V V
$I_{\text{CC}}$	Input DC Supply Current in Normal Operation	(Note 4) $V_{\text{ITH/RUN}} = 1.3\text{V}$		240	350	$\mu\text{A}$
$I_{\text{CC}}(\text{UV})$	Input DC Supply Current in Undervoltage	$V_{\text{CC}} = V_{\text{TURNON}} - 100\text{mV}$ LTC3803E-5 ● LTC3803I-5, LTC3803H-5, LTC3803MP-5 ●		40 40	90 100	$\mu\text{A}$ $\mu\text{A}$
$V_{\text{ITHSHDN}}$	Shutdown Threshold (at $I_{\text{TH/RUN}}$ )	$V_{\text{CC}} > V_{\text{TURNON}}$ , $V_{\text{ITH/RUN}}$ Falling LTC3803E-5 ● LTC3803I-5, LTC3803H-5 ● LTC3803MP-5 ●	0.12 0.08 0.08	0.28 0.28 0.28	0.45 0.45 0.47	V V V
$I_{\text{ITHSTART}}$	Start-Up Current Source	$V_{\text{ITH/RUN}} = 0\text{V}$ LTC3803E-5 ● LTC3803I-5, LTC3803H-5, LTC3803MP-5 ●	0.07 0.07	0.34 0.34	0.8 1	$\mu\text{A}$ $\mu\text{A}$
$V_{\text{FB}}$	Regulated Feedback Voltage	(Note 5) LTC3803E-5: $0^\circ\text{C} \leq T_J \leq 85^\circ\text{C}$ ● $-40^\circ\text{C} \leq T_J \leq 85^\circ\text{C}$ LTC3803I-5: $0^\circ\text{C} \leq T_J \leq 85^\circ\text{C}$ ● $-40^\circ\text{C} \leq T_J \leq 125^\circ\text{C}$ LTC3803H-5: $0^\circ\text{C} \leq T_J \leq 85^\circ\text{C}$ ● $-40^\circ\text{C} \leq T_J \leq 150^\circ\text{C}$ LTC3803MP-5: $0^\circ\text{C} \leq T_J \leq 85^\circ\text{C}$ ● $-55^\circ\text{C} \leq T_J \leq 150^\circ\text{C}$	0.788 0.780 0.788 0.780 0.788 0.780 0.788 0.780	0.800 0.800 0.800 0.800 0.800 0.800 0.800 0.800	0.812 0.816 0.812 0.820 0.812 0.820 0.812 0.820	V V V V V V V V
$g_m$	Error Amplifier Transconductance	$I_{\text{TH/RUN}}$ Pin Load = $\pm 5\mu\text{A}$ (Note 5)	200	333	500	$\mu\text{A/V}$
$\Delta V_{\text{O(LINE)}}$	Output Voltage Line Regulation	(Note 5)		0.1		mV/V
$\Delta V_{\text{O(LOAD)}}$	Output Voltage Load Regulation	$I_{\text{TH/RUN}}$ Sinking $5\mu\text{A}$ (Note 5) $I_{\text{TH/RUN}}$ Sourcing $5\mu\text{A}$ (Note 5)		3 3		mV/ $\mu\text{A}$ mV/ $\mu\text{A}$
$I_{\text{FB}}$	$V_{\text{FB}}$ Input Current	(Note 5)		10	50	nA
$f_{\text{OSC}}$	Oscillator Frequency	$V_{\text{ITH/RUN}} = 1.3\text{V}$	170	200	230	kHz
$\text{DC}_{\text{ON(MIN)}}$	Minimum Switch On Duty Cycle	$V_{\text{ITH/RUN}} = 1.3\text{V}$ , $V_{\text{FB}} = 0.8\text{V}$		6.5	8.5	%
$\text{DC}_{\text{ON(MAX)}}$	Maximum Switch On Duty Cycle	$V_{\text{ITH/RUN}} = 1.3\text{V}$ , $V_{\text{FB}} = 0.8\text{V}$	70	80	90	%
$t_{\text{RISE}}$	Gate Drive Rise Time	$C_{\text{LOAD}} = 3000\text{pF}$		40		ns
$t_{\text{FALL}}$	Gate Drive Fall Time	$C_{\text{LOAD}} = 3000\text{pF}$ (Note 7)		40		ns
$V_{\text{IMAX}}$	Peak Current Sense Voltage	$R_{\text{SL}} = 0$ (Note 6) LTC3803E-5 ● LTC3803I-5, LTC3803H-5 ● LTC3803MP-5 ●	90 85 85	100 100 100	115 115 120	mV mV mV
$I_{\text{SLMAX}}$	Peak Slope Compensation Output Current	(Note 7)		5		$\mu\text{A}$
$t_{\text{SFST}}$	Soft-Start Time			0.7		ms

## ELECTRICAL CHARACTERISTICS

**Note 1:** Stresses beyond those listed under Absolute Maximum Ratings may cause permanent damage to the device. Exposure to any Absolute Maximum Rating condition for extended periods may affect device reliability and lifetime.

**Note 2:** The LTC3803-5 is tested under pulsed load conditions such that  $T_J \approx T_A$ . The LTC3803E-5 is guaranteed to meet specifications from 0°C to 85°C junction temperature. Specifications over the -40°C to 125°C operating junction temperature range are assured by design, characterization and correlation with statistical process controls. The LTC3803I-5 is guaranteed over the -40°C to 125°C operating junction temperature range, the LTC3803H-5 is guaranteed over the -40°C to 150°C operating junction temperature range and the LTC3803MP-5 is tested and guaranteed over the full -55°C to 150°C operating junction temperature range. Note that the maximum ambient temperature consistent with these specifications is determined by specific operating conditions in conjunction with board layout, the rated package thermal impedance and other environmental factors.

Junction temperature ( $T_J$ ) is calculated from the ambient temperature  $T_A$  and the power dissipation  $P_D$  in the LTC3803-5 using the formula:

$$T_J = T_A + (P_D \cdot 230^\circ\text{C/W})$$

**Note 3:** High junction temperatures degrade operating lifetimes; operating lifetime is derated for junction temperatures greater than 125°C.

**Note 4:** Dynamic supply current is higher due to the gate charge being delivered at the switching frequency.

**Note 5:** The LTC3803-5 is tested in a feedback loop that servos  $V_{FB}$  to the output of the error amplifier while maintaining  $I_{TH}/RUN$  at the midpoint of the current limit range.

**Note 6:** Peak current sense voltage is reduced dependent on duty cycle and an optional external resistor in series with the SENSE pin ( $R_{SL}$ ). For details, refer to the programmable slope compensation feature in the Applications Information section.

**Note 7:** Guaranteed by design.

## TYPICAL PERFORMANCE CHARACTERISTICS

Reference Voltage vs Temperature

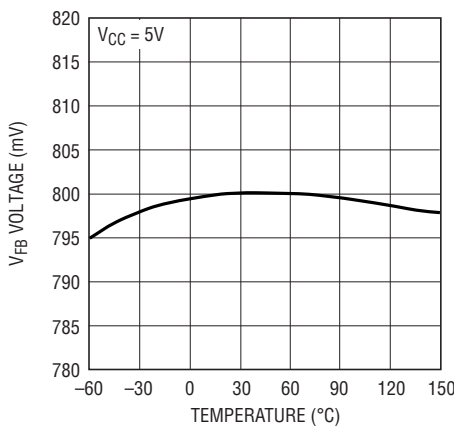

38035 G01

Reference Voltage vs Supply Voltage

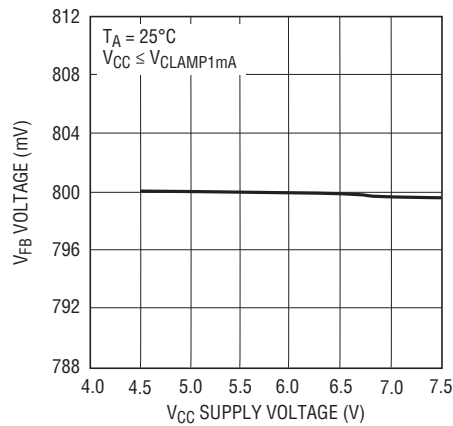

38035 G02

Reference Voltage vs V<sub>CC</sub> Shunt Regulator Current

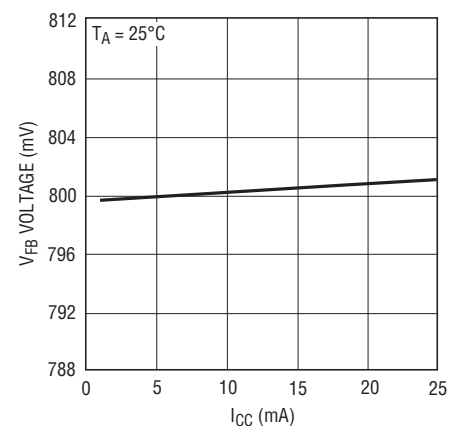

38035 G03

Oscillator Frequency vs Temperature

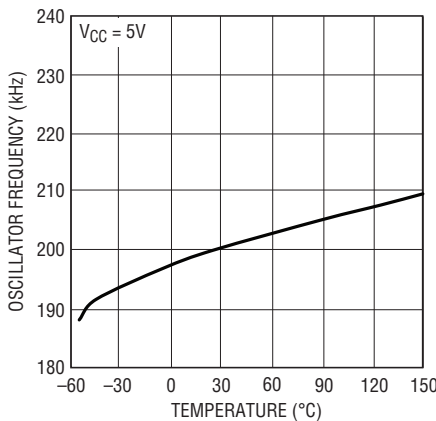

38035 G04

Oscillator Frequency vs Supply Voltage

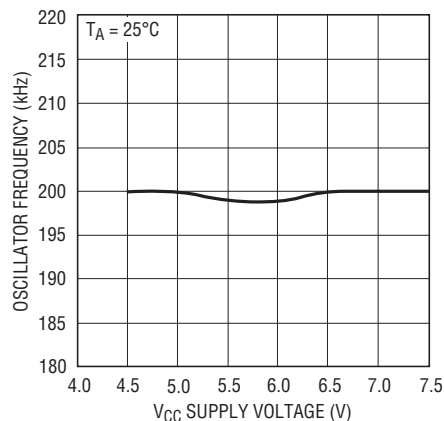

38035 G05

Oscillator Frequency vs V<sub>CC</sub> Shunt Regulator Current

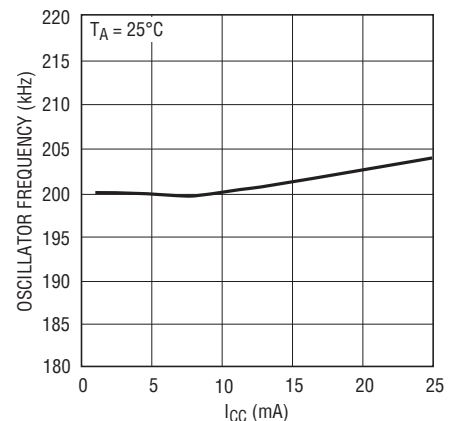

38035 G06  
38035fd

# TYPICAL PERFORMANCE CHARACTERISTICS

**V<sub>CC</sub> Undervoltage Lockout Thresholds vs Temperature**

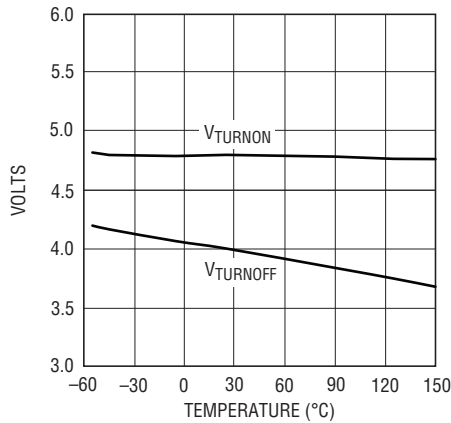

38035 G07

**V<sub>CC</sub> Shunt Regulator Voltage vs Temperature**

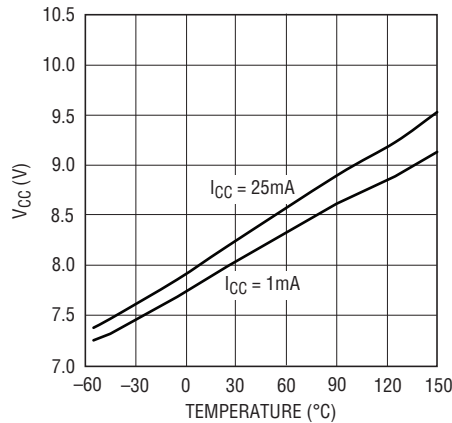

38035 G08

**I<sub>CC</sub> Supply Current vs Temperature**

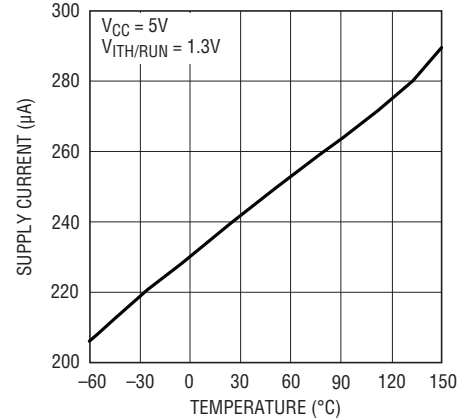

38035 G09

**Start-Up I<sub>CC</sub> Supply Current vs Temperature**

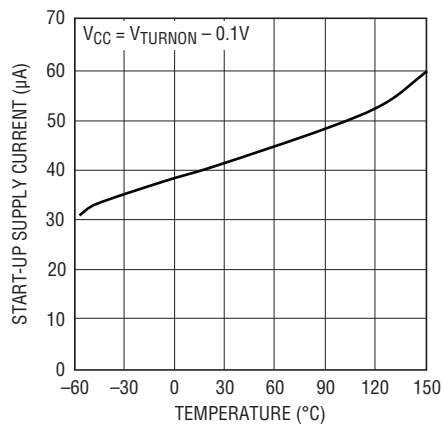

38035 G10

**I<sub>TH</sub>/RUN Shutdown Threshold vs Temperature**

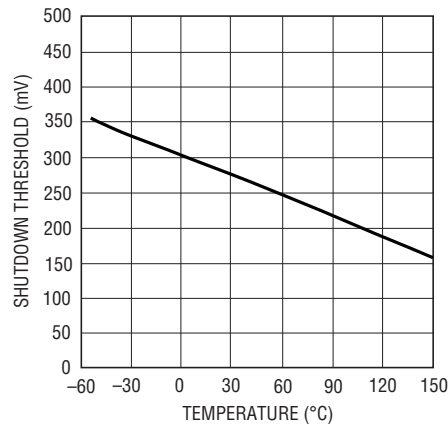

38035 G11

**I<sub>TH</sub>/RUN Start-Up Current Source vs Temperature**

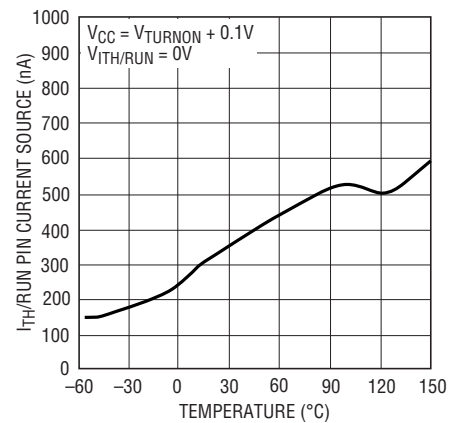

38035 G12

**Peak Current Sense Voltage vs Temperature**

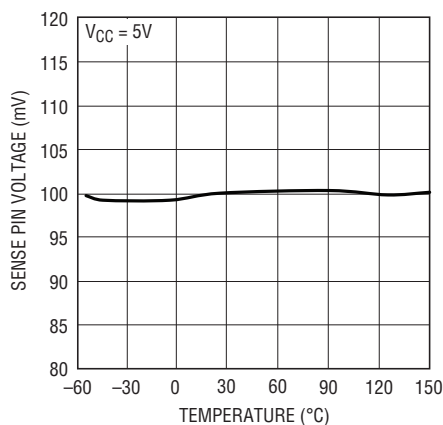

38035 G13

**Soft-Start Time vs Temperature**

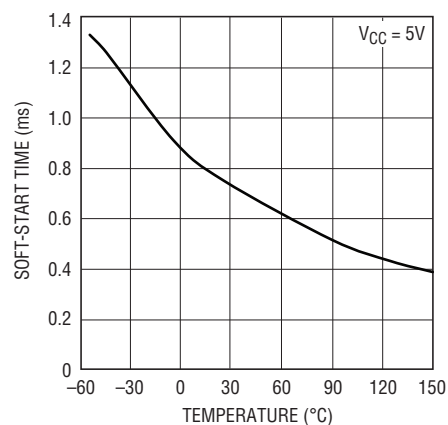

38035 G14

## PIN FUNCTIONS

**I<sub>TH</sub>/RUN (Pin 1):** This pin performs two functions. It serves as the error amplifier compensation point as well as the run/shutdown control input. Nominal voltage range is 0.7V to 1.9V. Forcing this pin below the shutdown threshold ( $V_{ITHSHDN}$ ) causes the LTC3803-5 to shut down. In shutdown mode, the NGATE pin is held low.

**GND (Pin 2):** Ground Pin.

**V<sub>FB</sub> (Pin 3):** Receives the feedback voltage from an external resistive divider across the output.

**SENSE (Pin 4):** This pin performs two functions. It monitors switch current by reading the voltage across an external current sense resistor to ground. It also injects a current ramp that develops slope compensation voltage across an optional external programming resistor.

**V<sub>CC</sub> (Pin 5):** Supply Pin. Must be closely decoupled to GND (Pin 2).

**NGATE (Pin 6):** Gate Drive for the External N-channel MOSFET. This pin swings from 0V to V<sub>CC</sub>.

## BLOCK DIAGRAM

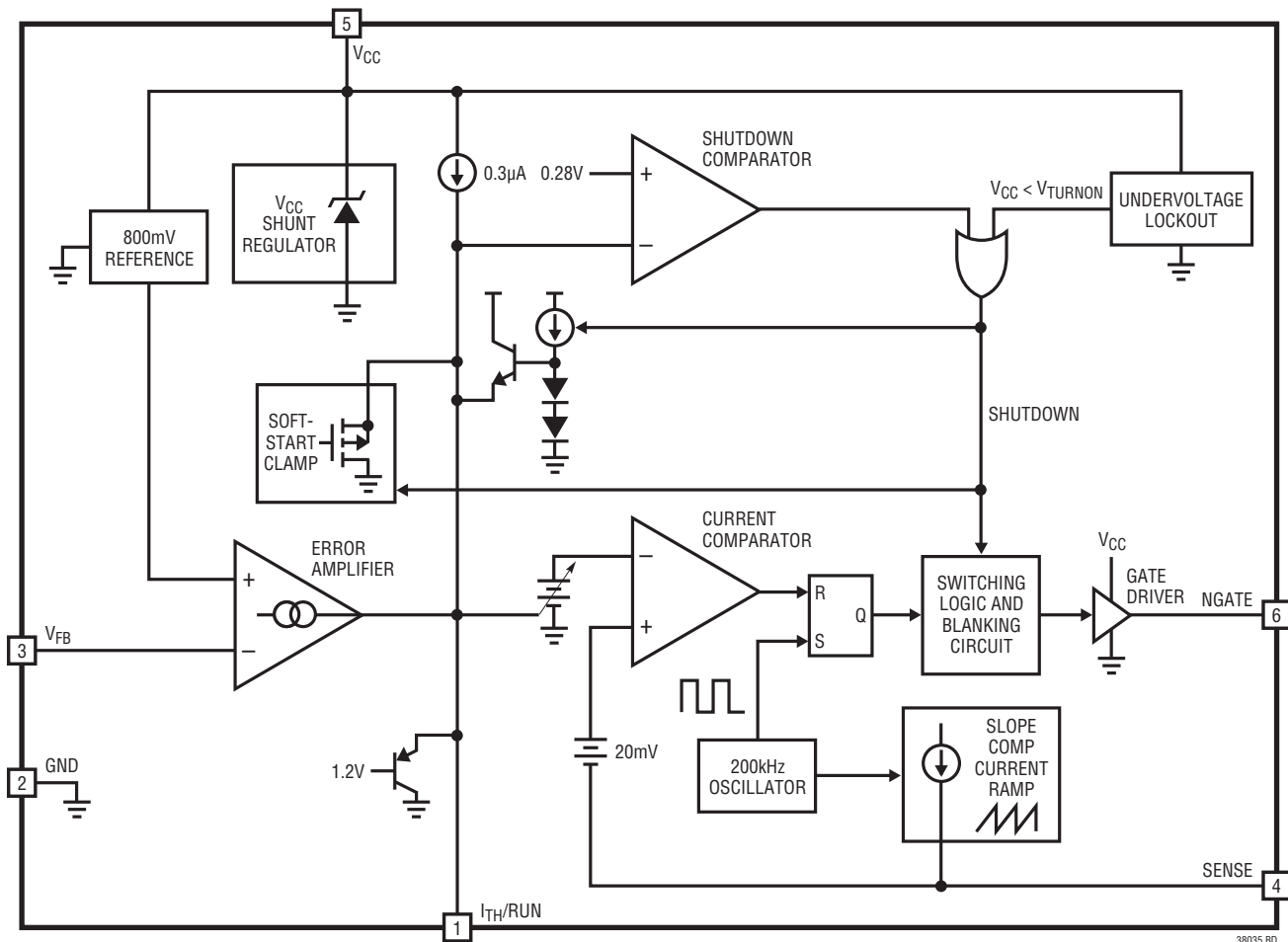

38035 BD

## OPERATION

The LTC3803-5 is a constant frequency current mode controller for flyback, SEPIC and DC/DC boost converter applications in a tiny ThinSOT package. The LTC3803-5 is designed so that none of its pins need to come in contact with the input or output voltages of the power supply circuit of which it is a part, allowing the conversion of voltages well beyond the LTC3803-5's absolute maximum ratings.

### Main Control Loop

Due to space limitations, the basics of current mode DC/DC conversion will not be discussed here; instead, the reader is referred to the detailed treatment in Application Note 19, or in texts such as Abraham Pressman's *Switching Power Supply Design*.

Please refer to the Block Diagram and the Typical Application on the front page of this data sheet. An external resistive voltage divider presents a fraction of the output voltage to the  $V_{FB}$  pin. The divider must be designed so that when the output is at the desired voltage, the  $V_{FB}$  pin voltage will equal the 800mV from the internal reference. If the load current increases, the output voltage will decrease slightly, causing the  $V_{FB}$  pin voltage to fall below 800mV. The error amplifier responds by feeding current into the  $I_{TH}/RUN$  pin. If the load current decreases, the  $V_{FB}$  voltage will rise above 800mV and the error amplifier will sink current away from the  $I_{TH}/RUN$  pin.

The voltage at the  $I_{TH}/RUN$  pin commands the pulse-width modulator formed by the oscillator, current comparator and RS latch. Specifically, the voltage at the  $I_{TH}/RUN$  pin sets the current comparator's trip threshold. The current comparator monitors the voltage across a current sense resistor in series with the source terminal of the external MOSFET. The LTC3803-5 turns on the external power MOSFET when the internal free-running 200kHz oscillator sets the RS latch. It turns off the MOSFET when the current comparator resets the latch or when 80% duty cycle is reached, whichever happens first. In this way, the peak current levels through the flyback transformer's primary and secondary are controlled by the  $I_{TH}/RUN$  voltage.

Since the  $I_{TH}/RUN$  voltage is increased by the error amplifier whenever the output voltage is below nominal, and decreased whenever output voltage exceeds nominal, the

voltage regulation loop is closed. For example, whenever the load current increases, output voltage will decrease slightly, and sensing this, the error amplifier raises the  $I_{TH}/RUN$  voltage by sourcing current into the  $I_{TH}/RUN$  pin, raising the current comparator threshold, thus increasing the peak currents through the transformer primary and secondary. This delivers more current to the load, bringing the output voltage back up.

The  $I_{TH}/RUN$  pin serves as the compensation point for the control loop. Typically, an external series RC network is connected from  $I_{TH}/RUN$  to ground and is chosen for optimal response to load and line transients. The impedance of this RC network converts the output *current* of the error amplifier to the  $I_{TH}/RUN$  *voltage* which sets the current comparator threshold and commands considerable influence over the dynamics of the voltage regulation loop.

### Start-Up/Shutdown

The LTC3803-5 has two shutdown mechanisms to disable and enable operation: an undervoltage lockout on the  $V_{CC}$  supply pin voltage, and a forced shutdown whenever external circuitry drives the  $I_{TH}/RUN$  pin low. The LTC3803-5 transitions into and out of shutdown according to the state diagram (Figure 1).

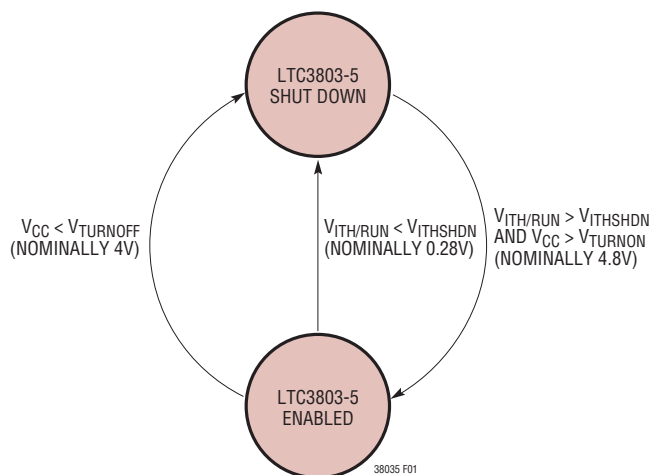

Figure 1. Start-Up/Shutdown State Diagram

## OPERATION

The undervoltage lockout (UVLO) mechanism prevents the LTC3803-5 from trying to drive a MOSFET with insufficient  $V_{GS}$ . The voltage at the  $V_{CC}$  pin must exceed  $V_{TURNON}$  (nominally 4.8V) at least momentarily to enable LTC3803-5 operation. The  $V_{CC}$  voltage is then allowed to fall to  $V_{TURNOFF}$  (nominally 4V) before undervoltage lockout disables the LTC3803-5.

The  $I_{TH}/RUN$  pin can be driven below  $V_{ITHSHDN}$  (nominally 0.28V) to force the LTC3803-5 into shutdown. An internal 0.3 $\mu$ A current source always tries to pull this pin towards  $V_{CC}$ . When the  $I_{TH}/RUN$  pin voltage is allowed to exceed  $V_{ITHSHDN}$ , and  $V_{CC}$  exceeds  $V_{TURNON}$ , the LTC3803-5 begins to operate and an internal clamp immediately pulls the  $I_{TH}/RUN$  pin up to about 0.7V. In operation, the  $I_{TH}/RUN$  pin voltage will vary from roughly 0.7V to 1.9V to represent current comparator thresholds from zero to maximum.

### Internal Soft-Start

An internal soft-start feature is enabled whenever the LTC3803-5 comes out of shutdown. Specifically, the  $I_{TH}/RUN$  voltage is clamped and is prevented from reaching maximum until roughly 0.7ms has passed. This allows the input and output currents of LTC3803-5-based power supplies to rise in a smooth and controlled manner on start-up.

### Powering the LTC3803-5

In the simplest case, the LTC3803-5 can be powered from a high voltage supply through a resistor. A built-in shunt regulator from the  $V_{CC}$  pin to GND will draw as much current as needed through this resistor to regulate the  $V_{CC}$  voltage to around 8.1V as long as the  $V_{CC}$  pin is not forced to sink more than 25mA. This shunt regulator is always active, even when the LTC3803-5 is in shutdown, since it serves the vital function of protecting the  $V_{CC}$  pin from seeing too much voltage.

The  $V_{CC}$  pin must be bypassed to ground immediately adjacent to the IC pins with a ceramic or tantalum capacitor. Proper supply bypassing is necessary to supply the high transient currents required by the MOSFET gate driver. 10 $\mu$ F is a good starting point.

### Adjustable Slope Compensation

The LTC3803-5 injects a 5 $\mu$ A peak current ramp out through its SENSE pin which can be used for slope compensation in designs that require it. This current ramp is approximately linear and begins at zero current at 6.5% duty cycle, reaching peak current at 80% duty cycle. Additional details are provided in the Applications Information section.



## APPLICATIONS INFORMATION

### Leakage Inductance

Transformer leakage inductance (on either the primary or secondary) causes a voltage spike to occur after the output switch (Q1) turn-off. This is increasingly prominent at higher load currents, where more stored energy must be dissipated. In some cases a “snubber” circuit will be required to avoid overvoltage breakdown at the MOSFET’s drain node. Application Note 19 is a good reference on snubber design.

A bifilar or similar winding technique is a good way to minimize troublesome leakage inductances. However, remember that this will limit the primary-to-secondary breakdown voltage, so bifilar winding is not always practical.

### CURRENT SENSE RESISTOR CONSIDERATIONS

The external current sense resistor ( $R_{\text{SENSE}}$  in Figure 2) allows the user to optimize the current limit behavior for the particular application. As the current sense resistor is varied from several ohms down to tens of milliohms, peak switch current goes from a fraction of an ampere to several amperes. Care must be taken to ensure proper circuit operation, especially with small current sense resistor values.

For example, a peak switch current of 5A requires a sense resistor of  $0.020\Omega$ . Note that the instantaneous peak power in the sense resistor is 0.5W and it must be rated accordingly. The LTC3803-5 has only a single sense line to this resistor. Therefore, any parasitic resistance in the ground side connection of the sense resistor will increase its apparent value. In the case of a  $0.020\Omega$  sense resistor, *one milliohm* of parasitic resistance will cause a 5% reduction in peak switch current. So the resistance of printed circuit copper traces and vias cannot necessarily be ignored.

### PROGRAMMABLE SLOPE COMPENSATION

The LTC3803-5 injects a ramping current through its SENSE pin into an external slope compensation resistor ( $R_{\text{SL}}$  in Figure 2). This current ramp starts at zero right after the NGATE pin has been high for the LTC3803-5’s minimum duty cycle of 6.5%. The current rises linearly towards a peak of  $5\mu\text{A}$  at the maximum duty cycle of 80%, shutting off once the NGATE pin goes low. A series resistor ( $R_{\text{SL}}$ ) connecting the SENSE pin to the current sense resistor ( $R_{\text{SENSE}}$ ) thus develops a ramping voltage drop. From the perspective of the SENSE pin, this ramping voltage adds to the voltage across the sense resistor, effectively reducing the current comparator threshold in proportion

## APPLICATIONS INFORMATION

to duty cycle. This stabilizes the control loop against subharmonic oscillation. The amount of reduction in the current comparator threshold ( $\Delta V_{\text{SENSE}}$ ) can be calculated using the following equation:

$$\Delta V_{\text{SENSE}} = \frac{\text{Duty Cycle} - 6.5\%}{73.5\%} \cdot 5\mu\text{A} \cdot R_{\text{SL}}$$

Note: LTC3803-5 enforces  $6.5\% < \text{Duty Cycle} < 80\%$ .

A good starting value for  $R_{\text{SL}}$  is 5.9k, which gives a 30mV drop in current comparator threshold at 80% duty cycle. Designs not needing slope compensation may replace  $R_{\text{SL}}$  with a short circuit.

### $V_{\text{CC}}$ SHUNT REGULATOR

An internal shunt regulator allows the LTC3803-5 to be powered through a single dropping resistor from  $V_{\text{IN}}$  to  $V_{\text{CC}}$ , in conjunction with a bypass capacitor,  $C_{\text{VCC}}$ , that closely decouples  $V_{\text{CC}}$  to GND (see Figure 3). The shunt regulator can draw up to 25mA through the  $V_{\text{CC}}$  pin to

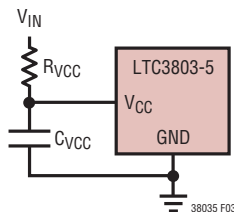

Figure 3. Powering the LTC3803-5 Via the Internal Shunt Regulator

GND to drop enough voltage across  $R_{\text{VCC}}$  to regulate  $V_{\text{CC}}$  to around 8.1V. For applications where  $V_{\text{IN}}$  is low enough such that the static power dissipation in  $R_{\text{VCC}}$  is acceptable, using the  $V_{\text{CC}}$  shunt regulator is the simplest way to power the LTC3803-5.

### EXTERNAL PREREGULATOR

The circuit in Figure 4 shows another way to power the LTC3803-5. An external series preregulator consisting of series pass transistor Q1, Zener diode D1, and bias resistor  $R_{\text{B}}$  brings  $V_{\text{CC}}$  above the  $V_{\text{CC}}$  turn-on threshold, enabling the LTC3803-5.

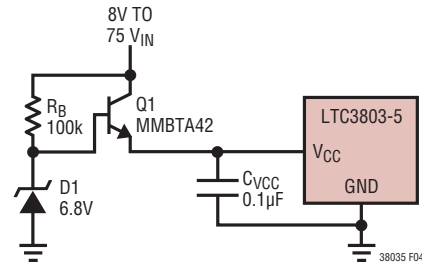
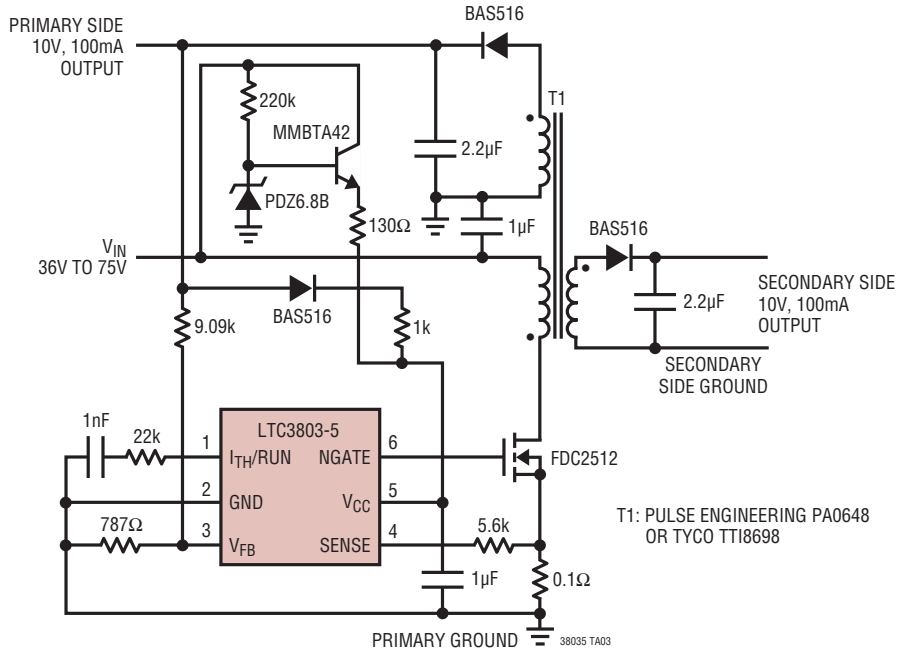

Figure 4. Powering the LTC3803-5 with an External Preregulator

TYPICAL APPLICATIONS

2W Isolated Housekeeping Telecom Converter



# TYPICAL APPLICATIONS

## 4:1 Input Range 3.3V Output Isolated Flyback DC/DC Converter

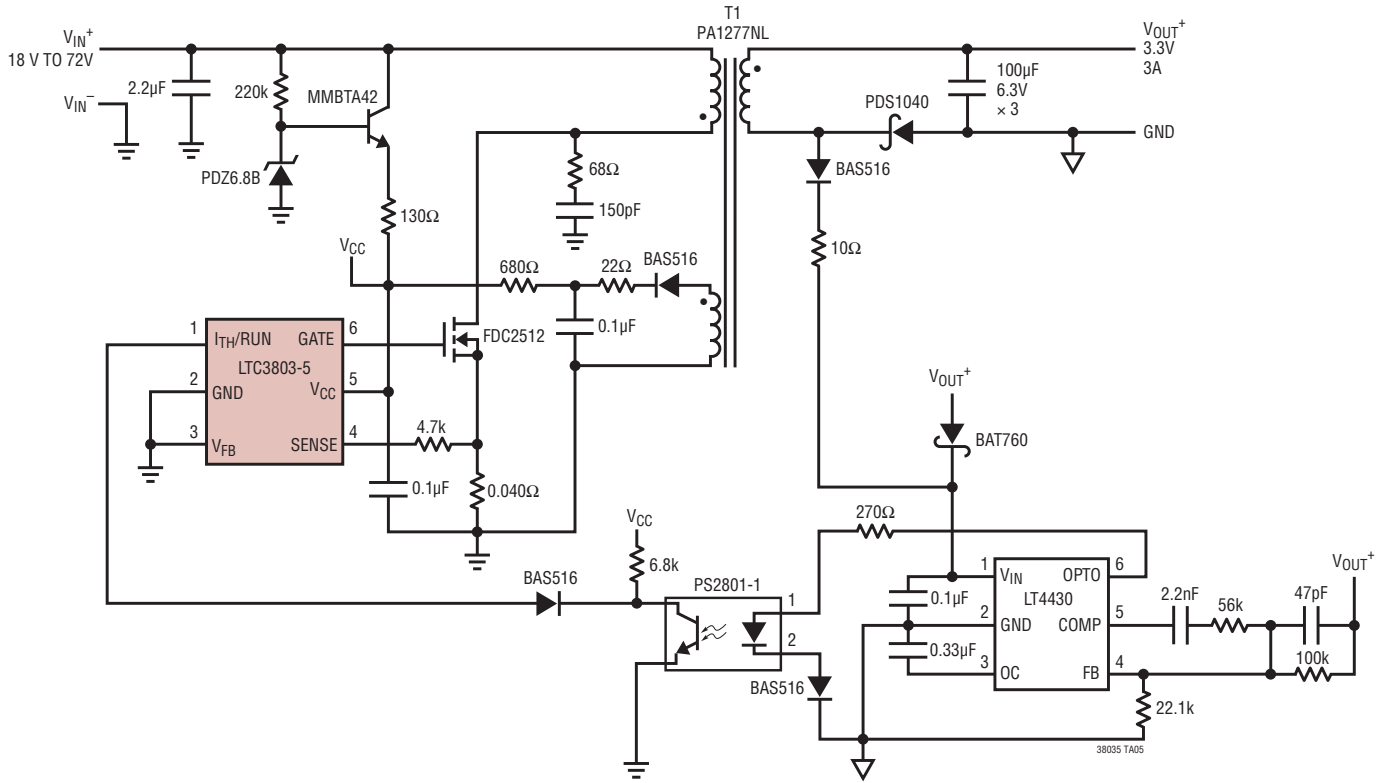

Efficiency vs Load Current

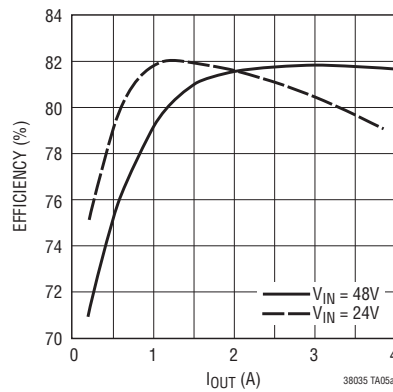

**PACKAGE DESCRIPTION**

**S6 Package**  
**6-Lead Plastic TSOT-23**  
 (Reference LTC DWG # 05-08-1636)

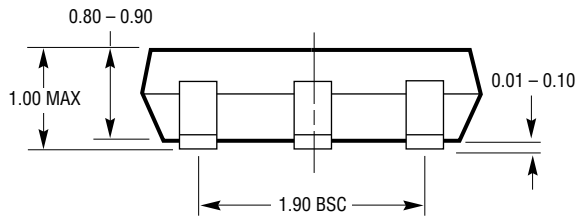
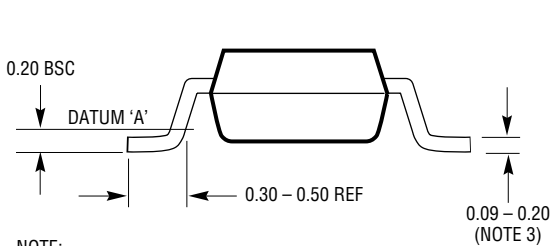
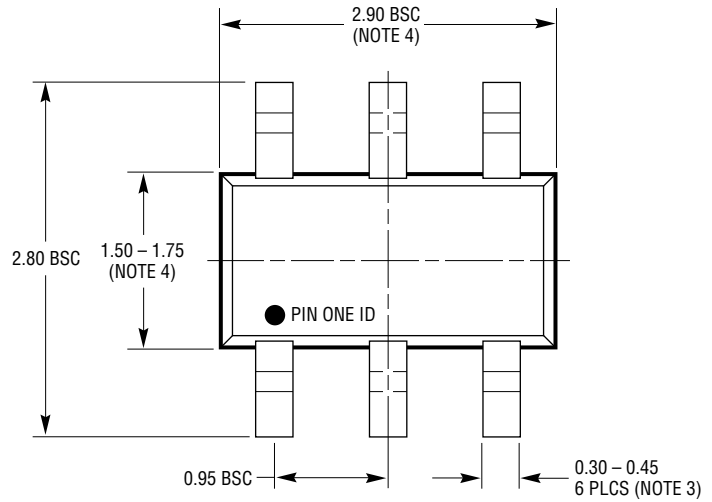
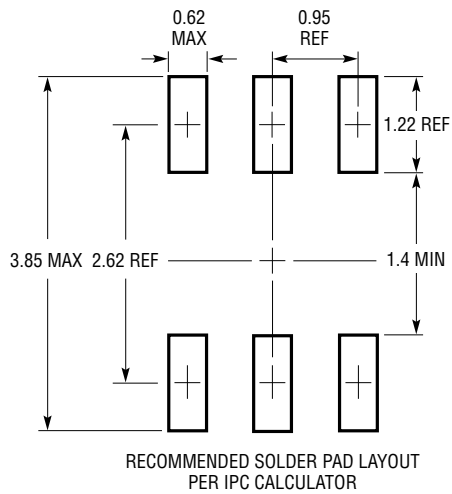

S6 TSOT-23 0302 REV B

- NOTE:
1. DIMENSIONS ARE IN MILLIMETERS
  2. DRAWING NOT TO SCALE
  3. DIMENSIONS ARE INCLUSIVE OF PLATING
  4. DIMENSIONS ARE EXCLUSIVE OF MOLD FLASH AND METAL BURR
  5. MOLD FLASH SHALL NOT EXCEED 0.254mm
  6. JEDEC PACKAGE REFERENCE IS MO-193

**REVISION HISTORY** (Revision history begins at Rev D)

REV	DATE	DESCRIPTION	PAGE NUMBER
D	6/10	MP-grade part added. Reflected throughout the data sheet.	1 to 16

## TYPICAL APPLICATION

### Synchronous Flyback Converter

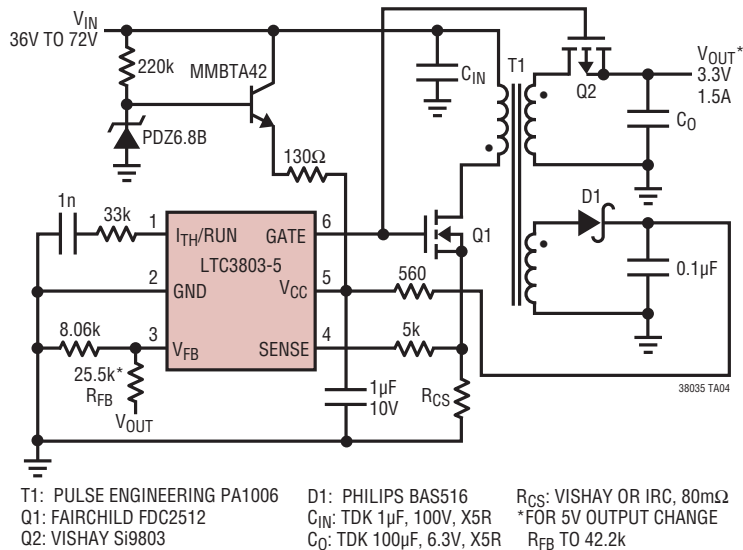

## RELATED PARTS

PART NUMBER	DESCRIPTION	COMMENTS
LT3573	Isolated Flyback Switching Regulator with 60V Integrated Switch	$3V \leq V_{IN} \leq 40V$ , No Opto-Isolator or Third Winding Required, Up to 7W Output Power, MSOP-16E
LTC3805/ LTC3805-5	Adjustable Constant Frequency Flyback, Boost, SEPIC DC/DC Controller	$V_{IN}$ and $V_{OUT}$ Limited Only by External Components, 3mm × 3mm DFN-10, MSOP-10E Packages
LTC3873/ LTC3873-5	No $R_{SENSE}^{\text{TM}}$ Constant Frequency Flyback, Boost, SEPIC Controller	$V_{IN}$ and $V_{OUT}$ Limited Only by External Components, 8-pin ThinSOT or 2mm × 3mm DFN-8 Packages
LT3757	Boost, Flyback, SEPIC and Inverting Controller	$2.9V \leq V_{IN} \leq 40V$ , 100kHz to 1MHz Programmable Operating Frequency, 3mm × 3mm DFN-10 and MSOP-10E Package
LT3758	Boost, Flyback, SEPIC and Inverting Controller	$5.5V \leq V_{IN} \leq 100V$ , 100kHz to 1MHz Programmable Operating Frequency, 3mm × 3mm DFN-10 and MSOP-10E
LTC1871/LTC1871-1/ LTC1871-7	Wide Input Range, No $R_{SENSE}$ Low Quiescent Current Flyback, Boost and SEPIC Controller	Programmable Operating Frequency, $2.5V \leq V_{IN} \leq 36V$ , Burst Mode <sup>®</sup> Operation at Light Load, MSOP-10

## Looking for pricing, stock, or lifecycle information?

Click below to explore more details on WIN SOURCE:

 [View LTC3803IS6-5#TRMPBF on WIN SOURCE](#)

 [Linear Technology](#) Information

## Optimize Your Supply Chain with WIN SOURCE Solutions

-  Global Sourcing Solution
-  Obsolete Management
-  Cost Control Management
-  Shortage Management
-  Alternative Solution
-  Excess Inventory Management