



**THE DATASHEET OF  
LTC3851EMSE-1#TRPBF**



# Synchronous Step-Down Switching Regulator Controller

## FEATURES

- Wide  $V_{IN}$  Range: 4V to 38V Operation
- $R_{SENSE}$  or DCR Current Sensing
- $\pm 1\%$  Output Voltage Accuracy
- Power Good Output Voltage Monitor
- Phase-Lockable Fixed Frequency: 250kHz to 750kHz
- Dual N-Channel MOSFET Synchronous Drive
- Very Low Dropout Operation: 99% Duty Cycle
- Adjustable Output Voltage Soft-Start or Tracking
- Output Current Foldback Limiting
- Output Overvoltage Protection
- OPTI-LOOP<sup>®</sup> Compensation Minimizes  $C_{OUT}$
- Selectable Continuous, Pulse-Skipping or Burst Mode<sup>®</sup> Operation at Light Loads
- Low Shutdown  $I_Q$ : 20 $\mu$ A
- $V_{OUT}$  Range: 0.8V to 5.5V
- Thermally Enhanced 16-Lead MSOP or 3mm  $\times$  3mm QFN Package

## APPLICATIONS

- Automotive Systems
- Telecom Systems
- Industrial Equipment
- Distributed DC Power Systems

## DESCRIPTION

The LTC<sup>®</sup>3851-1 is a high performance synchronous step-down switching regulator controller that drives an all N-channel synchronous power MOSFET stage. A constant frequency current mode architecture allows a phase-lockable frequency of up to 750kHz.

OPTI-LOOP compensation allows the transient response to be optimized over a wide range of output capacitance and ESR values. The LTC3851-1 features a precision 0.8V reference and a power good indicator. A wide 4V to 38V (40V absolute maximum) input supply range encompasses most battery configurations and intermediate bus voltages.

The TK/SS pin ramps the output voltage during start-up and shutdown with coincident or ratiometric tracking. Current foldback limits MOSFET heat dissipation during short-circuit conditions. The MODE/PLLIN pin selects among Burst Mode operation, pulse skipping mode or continuous inductor current mode at light loads and allows the IC to be synchronized to an external clock.

The LTC3851-1 is identical to the LTC3851 except that the  $I_{LIM}$  pin is replaced by PGOOD.

LT, LT, LTC, LTM, Burst Mode and OPTI-LOOP are registered trademarks of Linear Technology Corporation. All other trademarks are the property of their respective owners. Protected by U.S. Patents including 5408150, 5481178, 5705919, 5929620, 6304066, 6498466, 6580258, 6611131.

## TYPICAL APPLICATION

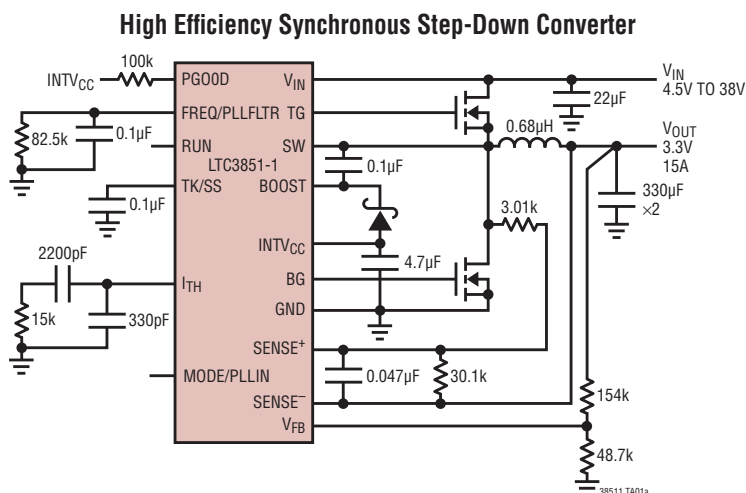

**Efficiency and Power Loss vs Load Current**

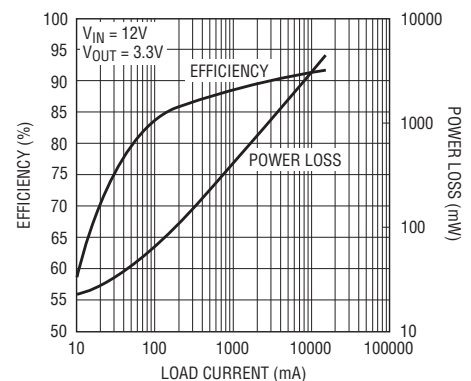

38511TA01b

38511fa

## ABSOLUTE MAXIMUM RATINGS (Note 1)

Input Supply Voltage ( $V_{IN}$ ) .....	40V to -0.3V	$I_{TH}$ , $V_{FB}$ Voltages .....	3V to -0.3V
Topside Driver Voltage (BOOST) .....	46V to -0.3V	INTV <sub>CC</sub> Peak Output Current .....	50mA
Switch Voltage (SW) .....	40V to -5V	Operating Junction Temperature Range	
INTV <sub>CC</sub> , (BOOST - SW), RUN, PGOOD .....	6V to -0.3V	(Notes 2, 3) .....	-40°C to 125°C
TK/SS .....	INTV <sub>CC</sub> to -0.3V	Storage Temperature Range .....	-65°C to 150°C
SENSE <sup>+</sup> , SENSE <sup>-</sup> .....	6V to -0.3V	Lead Temperature (Soldering, 10 sec)	
MODE/PLLIN, FREQ/PLLFLTR .....	INTV <sub>CC</sub> to -0.3V	MSE .....	300°C

## PIN CONFIGURATION

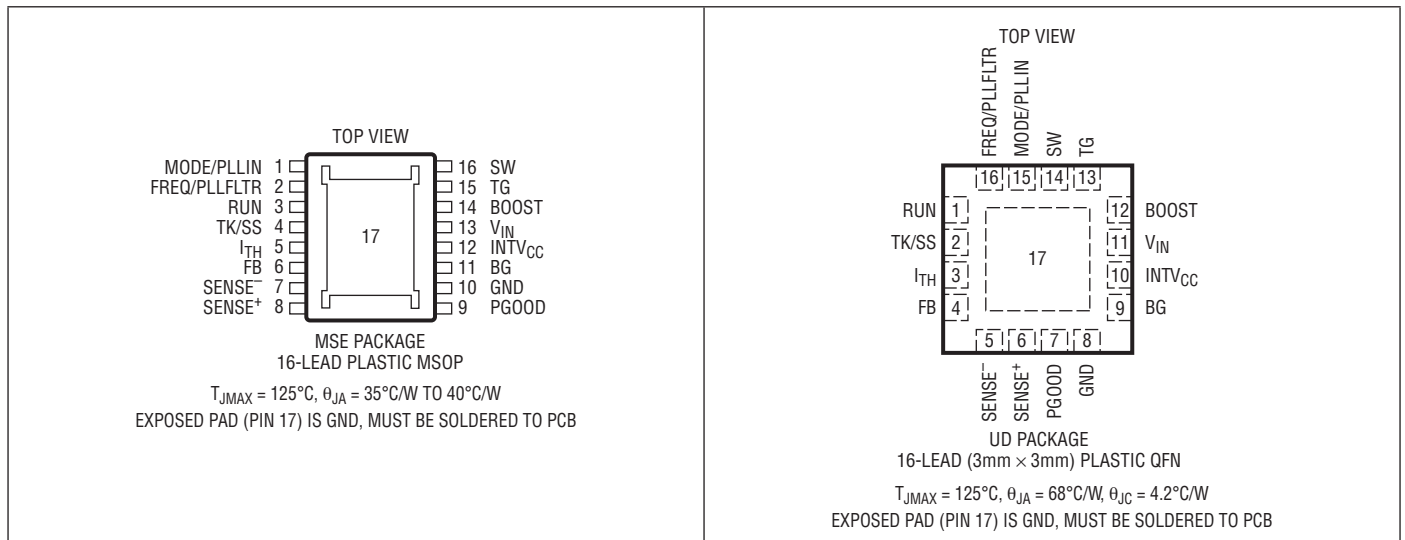

## ORDER INFORMATION

LEAD FREE FINISH	TAPE AND REEL	PART MARKING*	PACKAGE DESCRIPTION	TEMPERATURE RANGE
LTC3851EMSE-1#PBF	LTC3851EMSE-1#TRPBF	38511	16-Lead Plastic MSOP	-40°C to 85°C
LTC3851IMSE-1#PBF	LTC3851IMSE-1#TRPBF	38511	16-Lead Plastic MSOP	-40°C to 125°C
LTC3851EUD-1#PBF	LTC3851EUD-1#TRPBF	LDNT	16-Lead (3mm x 3mm) Plastic QFN	-40°C to 85°C
LTC3851IUD-1#PBF	LTC3851IUD-1#TRPBF	LDNT	16-Lead (3mm x 3mm) Plastic QFN	-40°C to 125°C

Consult LTC Marketing for parts specified with wider operating temperature ranges. \*The temperature grade is identified by a label on the shipping container. Consult LTC Marketing for information on non-standard lead based finish parts.

For more information on lead free part marking, go to: <http://www.linear.com/leadfree/>

For more information on tape and reel specifications, go to: <http://www.linear.com/tapeandreeel/>

## ELECTRICAL CHARACTERISTICS

The ● denotes the specifications which apply over the full operating junction temperature range, otherwise specifications are at  $T_A = 25^\circ\text{C}$ .  $V_{IN} = 15\text{V}$ ,  $V_{RUN} = 5\text{V}$  unless otherwise noted.

SYMBOL	PARAMETER	CONDITIONS	MIN	TYP	MAX	UNITS	
<b>Main Control Loops</b>							
$V_{IN}$	Input Operating Voltage Range		4		38	V	
$V_{FB}$	Regulated Feedback Voltage	$I_{TH} = 1.2\text{V}$ (Note 4)	● 0.792	0.800	0.808	V	
$I_{FB}$	Feedback Current	(Note 4)		-10	-50	nA	
$V_{REFLNREG}$	Reference Voltage Line Regulation	$V_{IN} = 6\text{V}$ to $38\text{V}$ (Note 4)		0.002	0.02	%/V	
$V_{LOADREG}$	Output Voltage Load Regulation	(Note 4) Measured in Servo Loop, $\Delta I_{TH} = 1.2\text{V}$ to $0.7\text{V}$	●	0.01	0.1	%	
		(Note 4) Measured in Servo Loop, $\Delta I_{TH} = 1.2\text{V}$ to $1.6\text{V}$	●	-0.01	-0.1	%	
$g_m$	Transconductance Amplifier $g_m$	$I_{TH} = 1.2\text{V}$ , Sink/Source = $5\mu\text{A}$ (Note 4)		2		mmho	
$g_m$ GBW	Transconductance Amp Gain Bandwidth	$I_{TH} = 1.2\text{V}$		3		MHz	
$I_Q$	Input DC Supply Current Normal Mode Shutdown	(Note 5) $V_{RUN} = 5\text{V}$ $V_{RUN} = 0\text{V}$		1		mA	
				20	35	$\mu\text{A}$	
UVLO	Undervoltage Lockout on $INTV_{CC}$	$V_{INTV_{CC}}$ Ramping Down		3.25		V	
UVLO Hys	UVLO Hysteresis			0.4		V	
$V_{OVL}$	Feedback Overvoltage Lockout	Measured at $V_{FB}$	● 0.86	0.88	0.90	V	
$I_{SENSE}$	SENSE Pins Current			$\pm 1$	$\pm 2$	$\mu\text{A}$	
$I_{TK/SS}$	Soft-Start Charge Current	$V_{TK/SS} = 0\text{V}$		0.6	1	$\mu\text{A}$	
$V_{RUN}$	RUN Pin On Threshold	$V_{RUN}$ Rising	● 1.10	1.25	1.35	V	
$V_{RUNHYS}$	RUN Pin On Hysteresis			130		mV	
$V_{SENSE(MAX)}$	Maximum Current Sense Threshold	$V_{FB} = 0.7\text{V}$ , $V_{SENSE} = 3.3\text{V}$	● 40	50	65	mV	
TG $R_{UP}$	TG Driver Pull-Up On-Resistance	TG High		2.6		$\Omega$	
TG $R_{DOWN}$	TG Driver Pull-Down On-Resistance	TG Low		1.5		$\Omega$	
BG $R_{UP}$	BG Driver Pull-Up On-Resistance	BG High		2.4		$\Omega$	
BG $R_{DOWN}$	BG Driver Pull-Down On-Resistance	BG Low		1.1		$\Omega$	
TG $t_r$ TG $t_f$	TG Transition Time Rise Time Fall Time	(Note 6) $C_{LOAD} = 3300\text{pF}$ $C_{LOAD} = 3300\text{pF}$		25		ns	
				25		ns	
BG $t_r$ BG $t_f$	BG Transition Time Rise Time Fall Time	(Note 6) $C_{LOAD} = 3300\text{pF}$ $C_{LOAD} = 3300\text{pF}$		25		ns	
				25		ns	
TG/BG $t_{1D}$	Top Gate Off to Bottom Gate On Delay Bottom Switch-On Delay Time	$C_{LOAD} = 3300\text{pF}$ Each Driver (Note 6)		30		ns	
BG/TG $t_{2D}$	Bottom Gate Off to Top Gate On Delay Top Switch-On Delay Time	$C_{LOAD} = 3300\text{pF}$ Each Driver (Note 6)		30		ns	
$t_{ON(MIN)}$	Minimum On-Time	(Note 7)		90		ns	
<b><math>INTV_{CC}</math> Linear Regulator</b>							
$V_{INTV_{CC}}$	Internal $V_{CC}$ Voltage	$6\text{V} < V_{IN} < 38\text{V}$		4.8	5	5.2	V
$V_{LDO INT}$	$INTV_{CC}$ Load Regulation	$I_{CC} = 0\text{mA}$ to $50\text{mA}$		0.5		%	
<b>Oscillator and Phase-Locked Loop</b>							
$f_{NOM}$	Nominal Frequency	$R_{FREQ} = 60\text{k}$		480	500	530	kHz
$f_{LOW}$	Lowest Frequency	$R_{FREQ} = 160\text{k}$		220	250	280	kHz

## ELECTRICAL CHARACTERISTICS

The ● denotes the specifications which apply over the full operating junction temperature range, otherwise specifications are at  $T_A = 25^\circ\text{C}$ .  $V_{IN} = 15\text{V}$ ,  $V_{RUN} = 5\text{V}$  unless otherwise noted.

SYMBOL	PARAMETER	CONDITIONS	MIN	TYP	MAX	UNITS
$f_{HIGH}$	Highest Frequency	$R_{FREQ} = 36\text{k}$	710	750	790	kHz
$R_{MODE/PLLIN}$	MODE/PLLIN Input Resistance			100		$\text{k}\Omega$
$f_{MODE}$	MODE/PLLIN Minimum Input Frequency	$V_{MODE} = \text{External Clock}$		250		kHz
	MODE/PLLIN Maximum Input Frequency	$V_{MODE} = \text{External Clock}$		750		kHz
$I_{FREQ}$	Phase Detector Output Current					
	Sinking Capability	$f_{MODE} > f_{OSC}$		-10		$\mu\text{A}$
	Sourcing Capability	$f_{MODE} < f_{OSC}$		10		$\mu\text{A}$

### PGOOD Output

$V_{PGL}$	PGOOD Voltage Low	$I_{PGOOD} = 2\text{mA}$		0.1	0.3	V
$I_{PGOOD}$	PGOOD Leakage Current	$V_{PGOOD} = 5\text{V}$			$\pm 1$	$\mu\text{A}$
$V_{PG}$	PGOOD Trip Level	$V_{FB}$ with Respect to Set Regulated Voltage				
		$V_{FB}$ Ramping Negative	-12	-10	-8	%
		$V_{FB}$ Ramping Positive	8	10	12	%

**Note 1:** Stresses beyond those listed under Absolute Maximum Ratings may cause permanent damage to the device. Exposure to any Absolute Maximum Rating condition for extended periods may affect device reliability and lifetime.

**Note 2:** The LTC3851E-1 is guaranteed to meet performance specifications from  $0^\circ\text{C}$  to  $85^\circ\text{C}$ . Specifications over the  $-40^\circ\text{C}$  to  $85^\circ\text{C}$  operating junction temperature range are assured by design, characterization and correlation with statistical process controls. The LTC3851-1 is guaranteed over the  $-40^\circ\text{C}$  to  $125^\circ\text{C}$  operating junction temperature range.

**Note 3:**  $T_J$  is calculated from the ambient temperature  $T_A$  and power dissipation  $P_D$  according to the following formulas:

$$\text{LTC3851MSE-1: } T_J = T_A + (P_D \cdot 90^\circ\text{C/W})$$

$$\text{LTC3851UD-1: } T_J = T_A + (P_D \cdot 68^\circ\text{C/W})$$

**Note 4:** The LTC3851-1 is tested in a feedback loop that serves  $V_{ITH}$  to a specified voltage and measures the resultant  $V_{FB}$ .

**Note 5:** Dynamic supply current is higher due to the gate charge being delivered at the switching frequency. See Applications Information.

**Note 6:** Rise and fall times are measured using 10% and 90% levels. Delay times are measured using 50% levels.

**Note 7:** The minimum on-time condition is specified for an inductor peak-to-peak ripple current  $\sim 40\%$  of  $I_{MAX}$  (see Minimum On-Time Considerations in the Applications Information section).

## TYPICAL PERFORMANCE CHARACTERISTICS

Efficiency vs Output Current and Mode

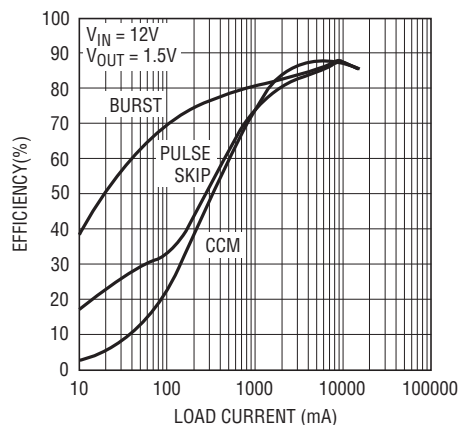

38511 G01

Efficiency vs Output Current and Mode

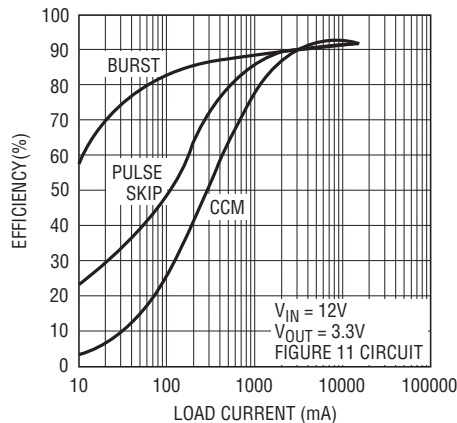

38511 G02

Efficiency vs Output Current and Mode

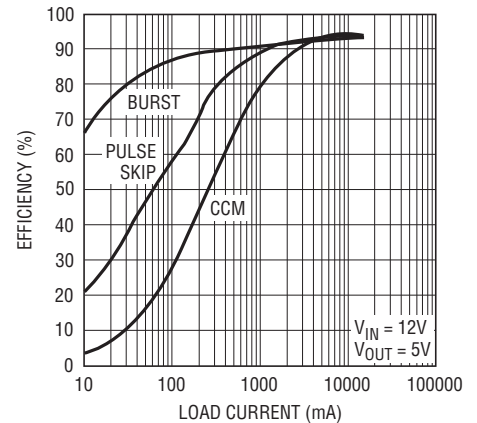

38511 G03

# TYPICAL PERFORMANCE CHARACTERISTICS

**Efficiency and Power Loss vs Input Voltage**

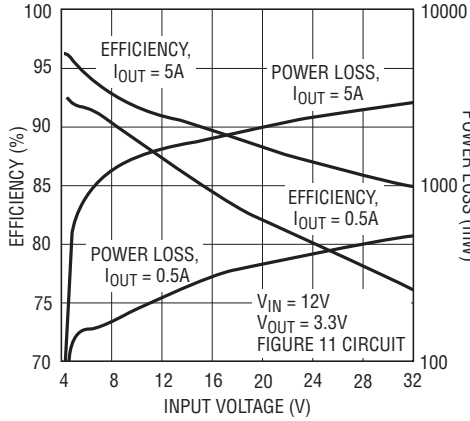

38511 G04

**Load Step (Burst Mode Operation)**

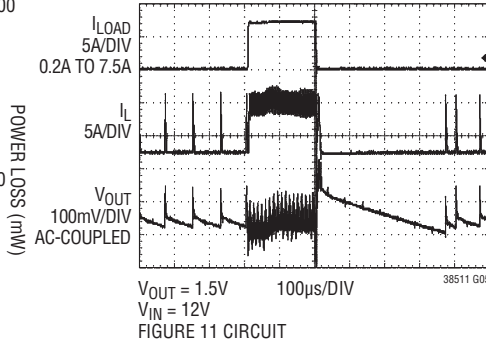

38511 G05

**Load Step (Forced Continuous Mode)**

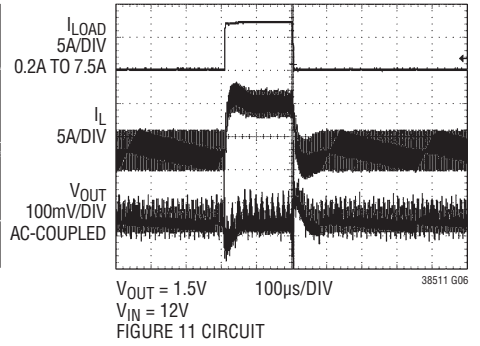

38511 G06

**Load Step (Pulse skip Mode)**

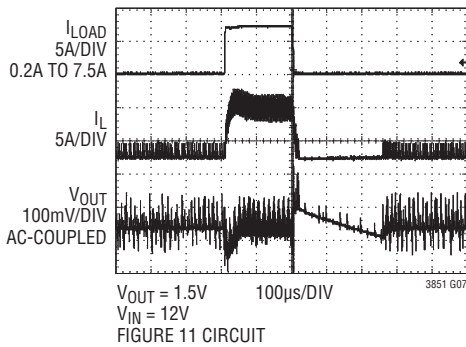

38511 G07

**Inductor Current at Light Load**

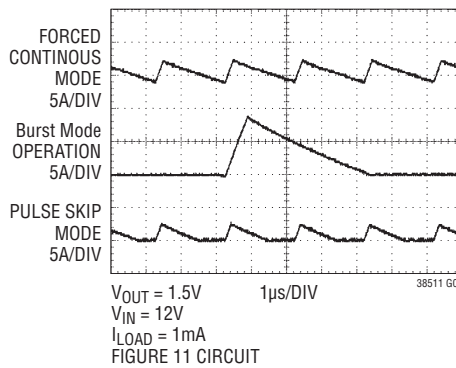

38511 G08

**Start-Up with Prebiased Output at 2V**

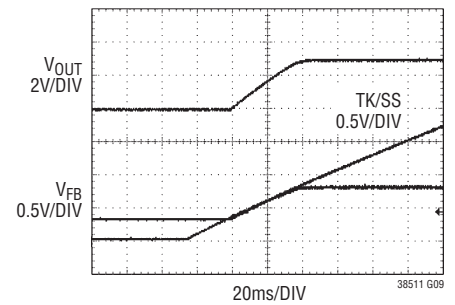

38511 G09

**Coincident Tracking with Master Supply**

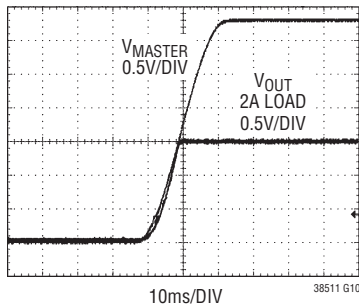

38511 G10

**Ratiometric Tracking with Master Supply**

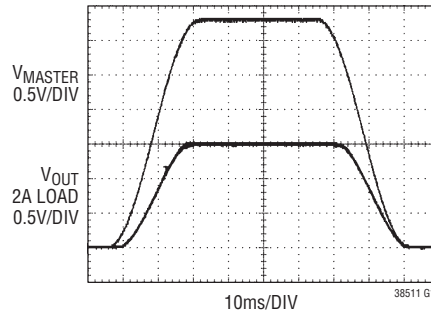

38511 G11

**Input DC Supply Current vs Input Voltage**

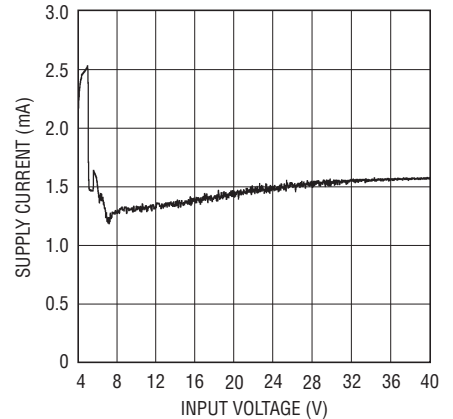

38511 G12

## TYPICAL PERFORMANCE CHARACTERISTICS

**INTV<sub>CC</sub> Line Regulation**

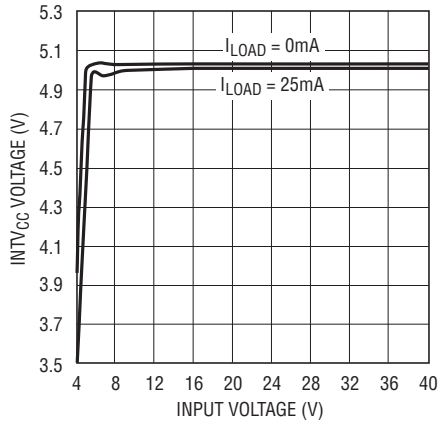

38511 G13

**Maximum Current Sense Threshold vs Common Mode Voltage**

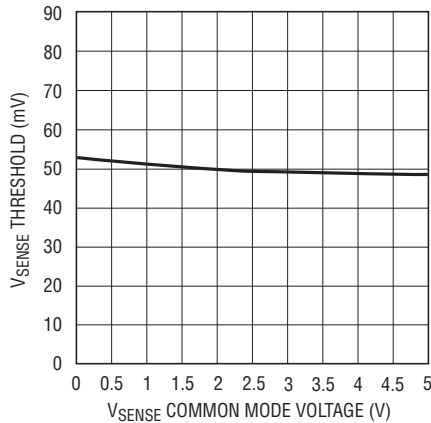

38511 G14

**Maximum Peak Current Sense Threshold vs I<sub>TH</sub> Voltage**

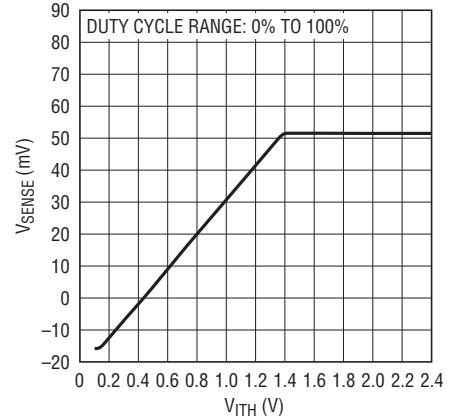

38511 G15

**Burst Mode Peak Current Sense Threshold vs I<sub>TH</sub> Voltage**

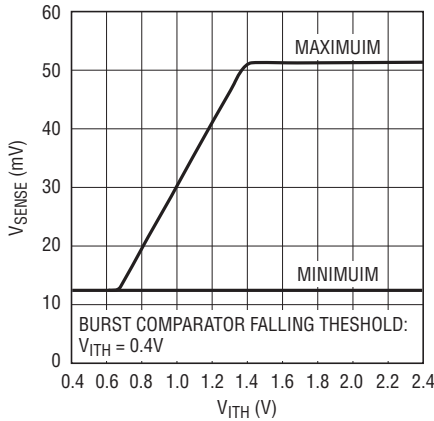

38511 G16

**Maximum Current Sense Threshold vs Duty Cycle**

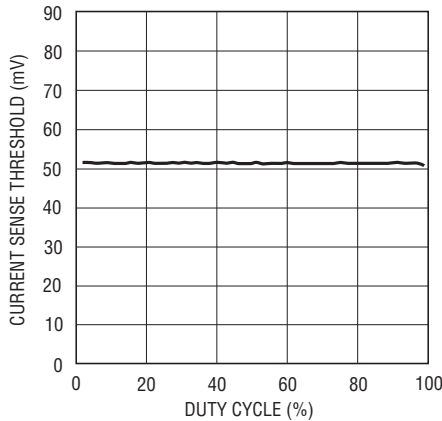

38511 G17

**Maximum Current Sense Threshold vs Feedback Voltage (Current Foldback)**

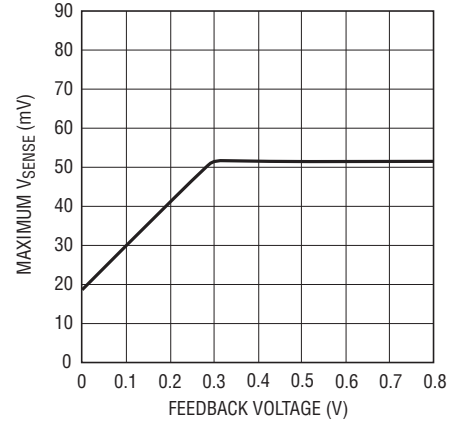

38511 G18

**TK/SS Pull-Up Current vs Temperature**

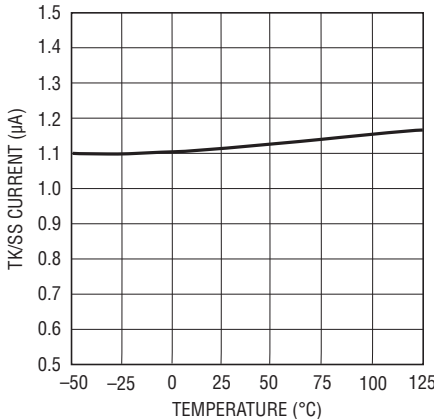

38511 G19

**Shutdown (RUN) Threshold vs Temperature**

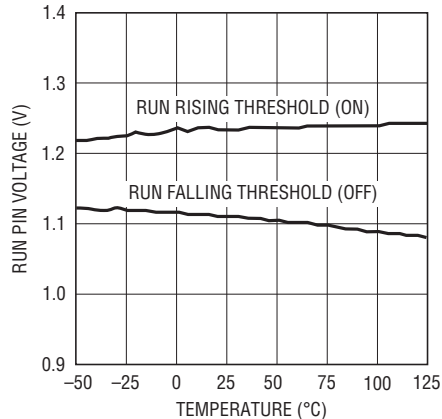

38511 G20

**Regulated Feedback Voltage vs Temperature**

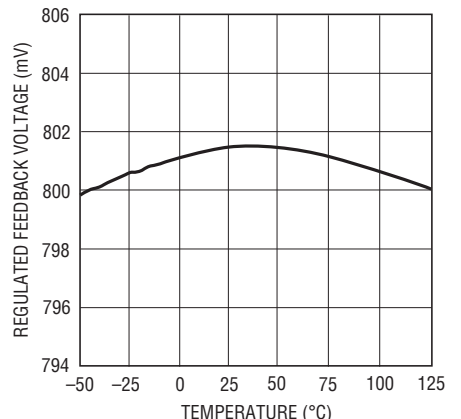

38511 G21  
38511fa

# TYPICAL PERFORMANCE CHARACTERISTICS

**Oscillator Frequency vs Temperature**

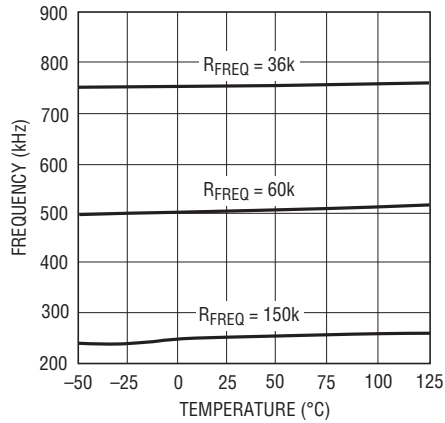

38511 G22

**Oscillator Frequency vs Input Voltage**

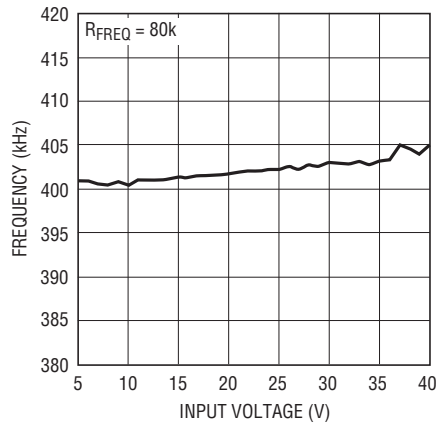

38511 G23

**Undervoltage Lockout Threshold (INTV<sub>CC</sub>) vs Temperature**

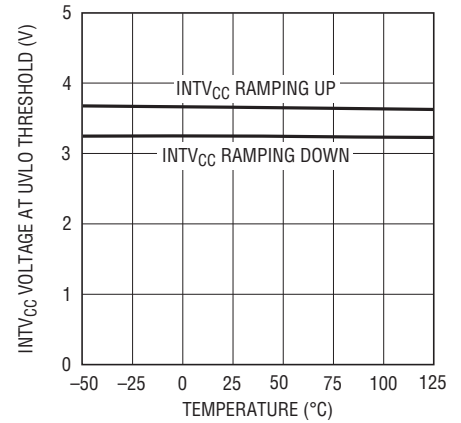

38511 G24

**Shutdown Input DC Supply Current vs Input Voltage**

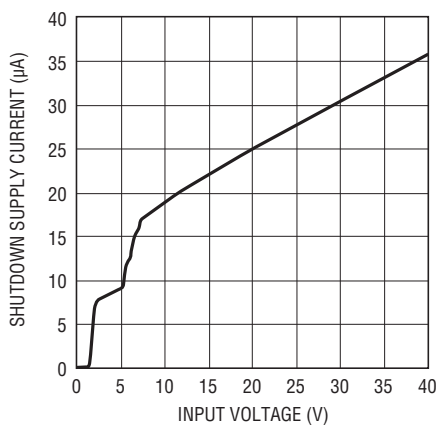

38511 G25

**Shutdown Input DC Supply Current vs Temperature**

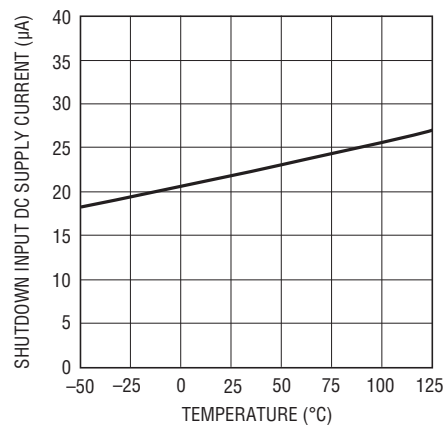

38511 G26

**Input DC Supply Current vs Temperature**

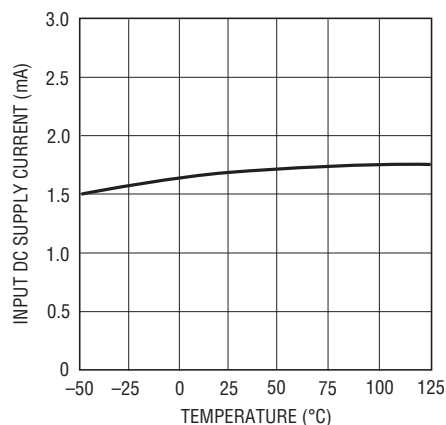

38511 G27

**Maximum Current Sense Threshold vs INTV<sub>CC</sub> Voltage**

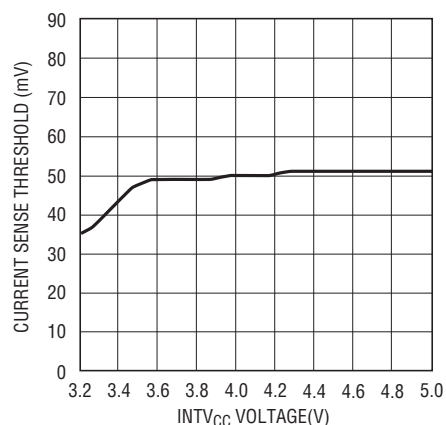

38511 G28

## PIN FUNCTIONS (MSE/UD)

**MODE/PLLIN (Pin 1/Pin 15):** Forced Continuous Mode, Burst Mode or Pulse skipping Mode Selection Pin and External Synchronization Input to Phase Detector Pin. Connect this pin to  $INTV_{CC}$  to force continuous conduction mode of operation. Connect to GND to enable pulse skipping mode of operation. To select Burst Mode operation, tie this pin to  $INTV_{CC}$  through a resistor no less than 50k, but no greater than 250k. A clock on the pin will force the controller into forced continuous mode of operation and synchronize the internal oscillator.

**FREQ/PLLFLTR (Pin 2/Pin 16):** The phase-locked loop's lowpass filter is tied to this pin. Alternatively, a resistor can be connected between this pin and GND to vary the frequency of the internal oscillator.

**RUN (Pin 3/Pin 1):** Run Control Input. A voltage above 1.25V on this pin turns on the IC. However, forcing this pin below 1.1V causes the IC to shut down the IC. There is a 2 $\mu$ A pull-up current on this pin.

**TK/SS (Pin 4/Pin 2):** Output Voltage Tracking and Soft-Start Input. A capacitor to ground at this pin sets the ramp rate for the output voltage. An internal soft-start current of 1 $\mu$ A charges this capacitor.

**$I_{TH}$  (Pin 5/Pin 3):** Current Control Threshold and Error Amplifier Compensation Point. The current comparator tripping threshold increases with its  $I_{TH}$  control voltage.

**FB (Pin 6/Pin 4):** Error Amplifier Feedback Input. This pin receives the remotely sensed feedback voltage from an external resistive divider across the output.

**SENSE<sup>-</sup> (Pin 7/Pin 5):** Current Sense Comparator Inverting Input. The (-) input to the current comparator is connected to the output.

**SENSE<sup>+</sup> (Pin 8/Pin 6):** Current Sense Comparator Noninverting Input. The (+) input to the current comparator is normally connected to the DCR sensing network or current sensing resistor.

**PGOOD (Pin 9/Pin 7):** Power Good Indicator Output. Open-drain logic out that is pulled to ground when the output voltage exceeds the  $\pm 10\%$  regulation window, after the internal 17 $\mu$ s power bad mask timer expires.

**GND (Pin 10/Pin 8):** Ground. All small-signal components and compensation components should be Kelvin connected to this ground. The (-) terminal of  $CV_{CC}$  and the (-) terminal of  $C_{IN}$  should be closely connected to this pin.

**BG (Pin 11/Pin 9):** Bottom Gate Driver Output. This pin drives the gate of the bottom N-channel MOSFET between GND and  $INTV_{CC}$ .

**INTV<sub>CC</sub> (Pin 12/Pin 10):** Internal 5V Regulator Output. The control circuit is powered from this voltage. Decouple this pin to GND with a minimum 2.2 $\mu$ F low ESR tantalum or ceramic capacitor.

**$V_{IN}$  (Pin 13/Pin 11):** Main Input Supply. Decouple this pin to GND with a capacitor.

**BOOST (Pin 14/Pin 12):** Boosted Floating Driver Supply. The (+) terminal of the boost-strap capacitor is connected to this pin. This pin swings from a diode voltage drop below  $INTV_{CC}$  up to  $V_{IN} + INTV_{CC}$ .

**TG (Pin 15/Pin 13):** Top Gate Driver Output. This is the output of a floating driver with a voltage swing equal to  $INTV_{CC}$  superimposed on the switch node voltage.

**SW (Pin 16/Pin 14):** Switch Node Connection to the Inductor. Voltage swing at this pin is from a Schottky diode (external) voltage drop below ground to  $V_{IN}$ .

**Exposed Pad (Pin 17):** Ground. Must be soldered to PCB, providing a local ground for the IC.

# FUNCTIONAL DIAGRAM

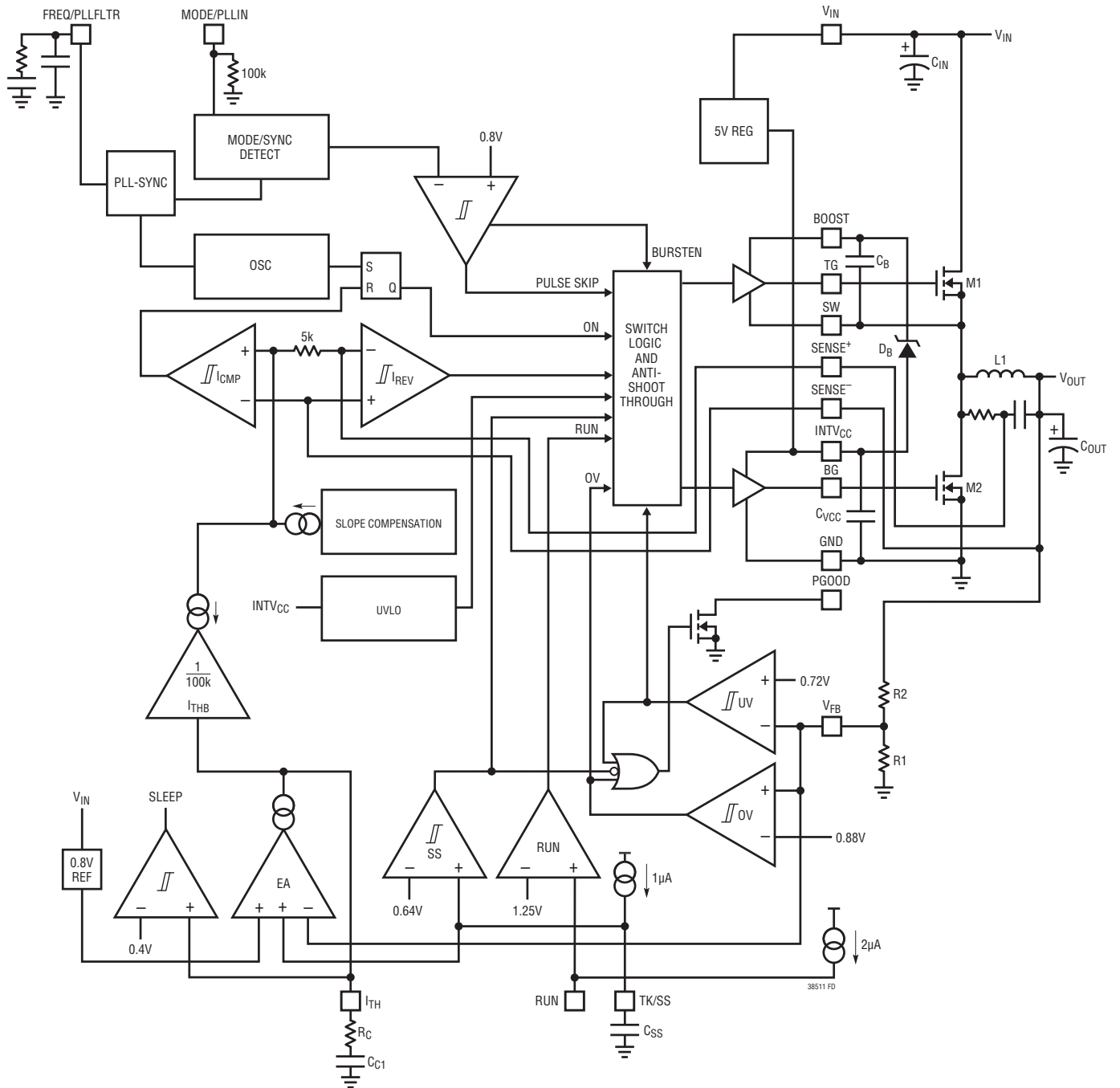

## OPERATION

### Main Control Loop

The LTC3851-1 is a constant frequency, current mode step-down controller. During normal operation, the top MOSFET is turned on when the clock sets the RS latch, and is turned off when the main current comparator,  $I_{CMP}$ , resets the RS latch. The peak inductor current at which  $I_{CMP}$  resets the RS latch is controlled by the voltage on the  $I_{TH}$  pin, which is the output of the error amplifier EA. The  $V_{FB}$  pin receives the voltage feedback signal, which is compared to the internal reference voltage by the EA. When the load current increases, it causes a slight decrease in  $V_{FB}$  relative to the 0.8V reference, which in turn causes the  $I_{TH}$  voltage to increase until the average inductor current matches the new load current. After the top MOSFET has turned off, the bottom MOSFET is turned on until either the inductor current starts to reverse, as indicated by the reverse current comparator,  $I_{REV}$ , or the beginning of the next cycle.

### INTV<sub>CC</sub> Power

Power for the top and bottom MOSFET drivers and most other internal circuitry is derived from the INTV<sub>CC</sub> pin. An internal 5V low dropout linear regulator supplies INTV<sub>CC</sub> power from  $V_{IN}$ .

The top MOSFET driver is biased from the floating bootstrap capacitor,  $C_B$ , which normally recharges during each off cycle through an external diode when the top MOSFET turns off. If the input voltage,  $V_{IN}$ , decreases to a voltage close to  $V_{OUT}$ , the loop may enter dropout and attempt to turn on the top MOSFET continuously. The dropout detector detects this and forces the top MOSFET off for about 1/10 of the clock period every tenth cycle to allow  $C_B$  to recharge. However, it is recommended that there is always a load present during the drop-out transition to ensure  $C_B$  is recharged.

### Shutdown and Start-Up (RUN and TK/SS)

The LTC3851-1 can be shut down using the RUN pin. Pulling this pin below 1.1V disables the controller and most of the internal circuitry, including the INTV<sub>CC</sub> regulator. Releasing the RUN pin allows an internal 2 $\mu$ A current to pull up the pin and enable that controller. Alternatively, the RUN pin may be externally pulled up or driven directly by logic.

Be careful not to exceed the absolute maximum rating of 6V on this pin.

The start-up of the controller's output voltage,  $V_{OUT}$ , is controlled by the voltage on the TK/SS pin. When the voltage on the TK/SS pin is less than the 0.8V internal reference, the LTC3851-1 regulates the  $V_{FB}$  voltage to the TK/SS pin voltage instead of the 0.8V reference. This allows the TK/SS pin to be used to program a soft-start by connecting an external capacitor from the TK/SS pin to GND. An internal 1 $\mu$ A pull-up current charges this capacitor creating a voltage ramp on the TK/SS pin. As the TK/SS voltage rises linearly from 0V to 0.8V (and beyond), the output voltage  $V_{OUT}$  rises smoothly from zero to its final value. Alternatively, the TK/SS pin can be used to cause the start-up of  $V_{OUT}$  to "track" another supply. Typically, this requires connecting to the TK/SS pin an external resistor divider from the other supply to ground (see the Applications Information section). When the RUN pin is pulled low to disable the controller, or when INTV<sub>CC</sub> drops below its undervoltage lockout threshold of 3.2V, the TK/SS pin is pulled low by an internal MOSFET. When in undervoltage lockout, the controller is disabled and the external MOSFETs are held off.

### Light Load Current Operation (Burst Mode Operation, Pulse skipping or Continuous Conduction)

The LTC3851-1 can be enabled to enter high efficiency Burst Mode operation, constant frequency pulse skipping mode or forced continuous conduction mode. To select forced continuous operation, tie the MODE/PLLIN pin to INTV<sub>CC</sub>. To select pulse skipping mode of operation, float the MODE/PLLIN pin or tie it to GND. To select Burst Mode operation, tie MODE/PLLIN to INTV<sub>CC</sub> through a resistor no less than 50k, but no greater than 250k.

When the controller is enabled for Burst Mode operation, the peak current in the inductor is set to approximately one-fourth of the maximum sense voltage even though the voltage on the  $I_{TH}$  pin indicates a lower value. If the average inductor current is higher than the load current, the error amplifier, EA, will decrease the voltage on the  $I_{TH}$  pin. When the  $I_{TH}$  voltage drops below 0.4V, the internal sleep signal goes high (enabling "sleep" mode) and both external MOSFETs are turned off.

## OPERATION

In sleep mode, the load current is supplied by the output capacitor. As the output voltage decreases, the EA's output begins to rise. When the output voltage drops enough, the sleep signal goes low, and the controller resumes normal operation by turning on the top external MOSFET on the next cycle of the internal oscillator. When a controller is enabled for Burst Mode operation, the inductor current is not allowed to reverse. The reverse current comparator,  $I_{REV}$ , turns off the bottom external MOSFET just before the inductor current reaches zero, preventing it from reversing and going negative. Thus, the controller operates in discontinuous operation. In forced continuous operation, the inductor current is allowed to reverse at light loads or under large transient conditions. The peak inductor current is determined by the voltage on the  $I_{TH}$  pin, just as in normal operation. In this mode the efficiency at light loads is lower than in Burst Mode operation. However, continuous mode has the advantages of lower output ripple and less interference to audio circuitry.

When the MODE/PLLIN pin is connected to GND, the LTC3851-1 operates in PWM pulse skipping mode at light loads. At very light loads the current comparator,  $I_{CMP}$ , may remain tripped for several cycles and force the external top MOSFET to stay off for the same number of cycles (i.e., skipping pulses). The inductor current is not allowed to reverse (discontinuous operation). This mode, like forced continuous operation, exhibits low output ripple as well as low audio noise and reduced RF interference as compared to Burst Mode operation. It provides higher low current efficiency than forced continuous mode, but not nearly as high as Burst Mode operation.

### Frequency Selection and Phase-Locked Loop (FREQ/PLLFLTR and MODE/PLLIN Pins)

The selection of switching frequency is a trade-off between efficiency and component size. Low frequency operation increases efficiency by reducing MOSFET switching losses, but requires larger inductance and/or capacitance to maintain low output ripple voltage. The switching frequency of the LTC3851-1 can be selected using the FREQ/PLLFLTR

pin. If the MODE/PLLIN pin is not being driven by an external clock source, the FREQ/PLLFLTR pin can be used to program the controller's operating frequency from 250kHz to 750kHz.

A phase-locked loop (PLL) is available on the LTC3851-1 to synchronize the internal oscillator to an external clock source that is connected to the MODE/PLLIN pin. The controller operates in forced continuous mode of operation when it is synchronized. A series RC should be connected between the FREQ/PLLFLTR pin and GND to serve as the PLL's loop filter.

It is suggested that the external clock be applied before enabling the controller unless a second resistor is connected in parallel with the series RC loop filter network. The second resistor prevents low switching frequency operation if the controller is enabled before the clock.

### Output Overvoltage Protection

An overvoltage comparator, OV, guards against transient overshoots (>10%) as well as other more serious conditions that may overvoltage the output. In such cases, the top MOSFET is turned off and the bottom MOSFET is turned on until the overvoltage condition is cleared.

### Power Good (PGOOD) Pin

The PGOOD pin is connected to an open drain of an internal N-channel MOSFET. The MOSFET turns on and pulls the PGOOD pin low when the  $V_{FB}$  pin voltage is not within  $\pm 10\%$  of the 0.8V reference voltage. The PGOOD pin is also pulled low when the RUN pin is low (shut down) or when the LTC3851-1 is in the soft-start or tracking phase. When the  $V_{FB}$  pin voltage is within the  $\pm 10\%$  requirement, the MOSFET is turned off and the pin is allowed to be pulled up by an external resistor to a source of up to 6V. The PGOOD pin will flag power good immediately when the  $V_{FB}$  pin is within the  $\pm 10\%$  window. However, there is an internal 17 $\mu$ s power bad mask when  $V_{FB}$  goes out of the  $\pm 10\%$  window.

## APPLICATIONS INFORMATION

The Typical Application on the first page of this data sheet is a basic LTC3851-1 application circuit. The LTC3851-1 can be configured to use either DCR (inductor resistance) sensing or low value resistor sensing. The choice of the two current sensing schemes is largely a design trade-off between cost, power consumption and accuracy. DCR sensing is becoming popular because it saves expensive current sensing resistors and is more power efficient, especially in high current applications. However, current sensing resistors provide the most accurate current limits for the controller. Other external component selection is driven by the load requirement, and begins with the selection of  $R_{SENSE}$  (if  $R_{SENSE}$  is used) and the inductor value. Next, the power MOSFETs and Schottky diodes are selected. Finally, input and output capacitors are selected. The circuit shown on the first page can be configured for operation up to 40V at  $V_{IN}$ .

### SENSE+ and SENSE- Pins

The SENSE+ and SENSE- pins are the inputs to the current comparators. The common mode input voltage range of the current comparators is 0V to 5.5V. Both SENSE pins are high impedance inputs with small base currents of less than 1 $\mu$ A. When the SENSE pins ramp up from 0V to 1.4V, the small base currents flow out of the SENSE pins. When the SENSE pins ramp down from 5V to 1.1V, the small base currents flow into the SENSE pins. The high impedance inputs to the current comparators allow accurate DCR sensing. However, care must be taken not to float these pins during normal operation.

### Low Value Resistors Current Sensing

A typical sensing circuit using a discrete resistor is shown in Figure 1.  $R_{SENSE}$  is chosen based on the required output current.

The current comparator has a maximum threshold,  $V_{MAX} = 50\text{mV}$ . The current comparator threshold sets the maximum peak of the inductor current, yielding a maximum average output current,  $I_{MAX}$ , equal to the peak value less half the peak-to-peak ripple current,  $\Delta I_L$ . Allowing a margin

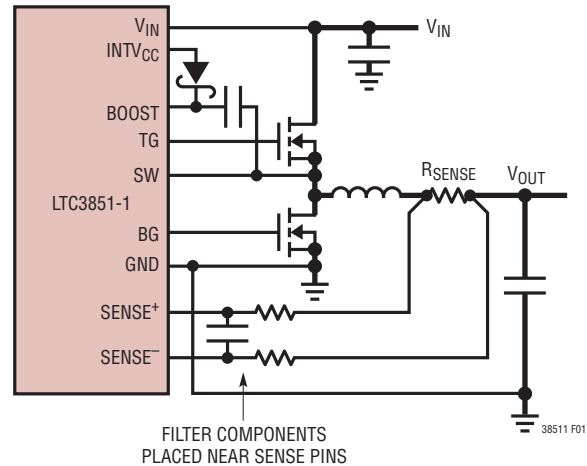

Figure 1. Using a Resistor to Sense Current with the LTC3851-1

of 20% for variations in the IC and external component values yields:

$$R_{SENSE} = 0.8 \cdot \frac{V_{MAX}}{I_{MAX} + \Delta I_L / 2}$$

### Inductor DCR Sensing

For applications requiring the highest possible efficiency, the LTC3851-1 is capable of sensing the voltage drop across the inductor DCR, as shown in Figure 2. The DCR of the inductor represents the small amount of DC winding resistance of the copper, which can be less than 1m $\Omega$  for today's low value, high current inductors. If the external  $R1 || R2 \cdot C1$  time constant is chosen to be exactly equal to the  $L/DCR$  time constant, the voltage drop across the external capacitor is equal to the voltage drop across the inductor DCR multiplied by  $R2/(R1 + R2)$ . Therefore,  $R2$  may be used to scale the voltage across the sense terminals when the DCR is greater than the target sense resistance. Check the manufacturer's data sheet for specifications regarding the inductor DCR, in order to properly dimension the external filter components. The DCR of the inductor can also be measured using a good RLC meter.

## APPLICATIONS INFORMATION

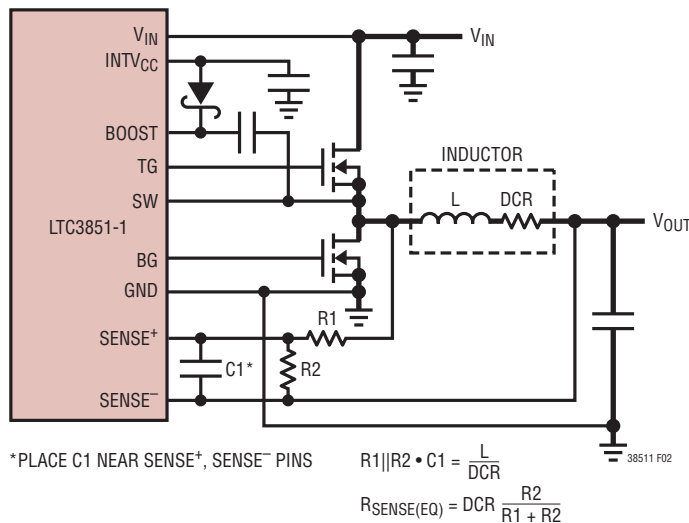

Figure 2. Current Mode Control Using the Inductor DCR

### Slope Compensation and Inductor Peak Current

Slope compensation provides stability in constant frequency architectures by preventing sub-harmonic oscillations at high duty cycles. It is accomplished internally by adding a compensating ramp to the inductor current signal. Normally, this results in a reduction of maximum inductor peak current for duty cycles >40%. However, the LTC3851-1 uses a novel scheme that allows the maximum inductor peak current to remain unaffected throughout all duty cycles.

### Inductor Value Calculation

The operating frequency and inductor selection are inter-related in that higher operating frequencies allow the use of smaller inductor and capacitor values. A higher frequency generally results in lower efficiency because of MOSFET gate charge losses. In addition to this basic trade-off, the effect of inductor value on ripple current and low current operation must also be considered.

The inductor value has a direct effect on ripple current. The inductor ripple current  $\Delta I_L$  decreases with higher inductance or frequency and increases with higher  $V_{IN}$ :

$$\Delta I_L = \frac{1}{f \cdot L} V_{OUT} \left( 1 - \frac{V_{OUT}}{V_{IN}} \right)$$

Accepting larger values of  $\Delta I_L$  allows the use of low inductances, but results in higher output voltage ripple and greater core losses. A reasonable starting point for setting ripple current is  $\Delta I_L = 0.3(I_{MAX})$ . The maximum  $\Delta I_L$  occurs at the maximum input voltage.

The inductor value also has secondary effects. The transition to Burst Mode operation begins when the average inductor current required results in a peak current below  $\approx 10\%$  of the current limit determined by  $R_{SENSE}$ . Lower inductor values (higher  $\Delta I_L$ ) will cause this to occur at lower load currents, which can cause a dip in efficiency in the upper range of low current operation. In Burst Mode operation, lower inductance values will cause the burst frequency to increase.

### Inductor Core Selection

Once the value for L is known, the type of inductor must be selected. High efficiency converters generally cannot afford the core loss found in low cost powdered iron cores, forcing the use of more expensive ferrite or molypermalloy cores. Actual core loss is independent of core size for a fixed inductor value, but it is very dependent on inductance selected. As inductance increases, core losses go down. Unfortunately, increased inductance requires more turns of wire and therefore copper losses will increase.

Ferrite designs have very low core loss and are preferred at high switching frequencies, so design goals can concentrate on copper loss and preventing saturation. Ferrite core material saturates “hard,” which means that inductance collapses abruptly when the peak design current is exceeded. This results in an abrupt increase in inductor ripple current and consequent output voltage ripple. Do not allow the core to saturate!

### Power MOSFET and Schottky Diode (Optional) Selection

Two external power MOSFETs must be selected for the LTC3851-1 controller: one N-channel MOSFET for the top (main) switch, and one N-channel MOSFET for the bottom (synchronous) switch.

## APPLICATIONS INFORMATION

The peak-to-peak drive levels are set by the  $INTV_{CC}$  voltage. This voltage is typically 5V during start-up. Consequently, logic-level threshold MOSFETs must be used in most applications. The only exception is if low input voltage is expected ( $V_{IN} < 5V$ ); then, sub-logic level threshold MOSFETs ( $V_{GS(TH)} < 3V$ ) should be used. Pay close attention to the  $BV_{DSS}$  specification for the MOSFETs as well; most of the logic-level MOSFETs are limited to 30V or less.

Selection criteria for the power MOSFETs include the on-resistance,  $R_{DS(ON)}$ , Miller capacitance,  $C_{MILLER}$ , input voltage and maximum output current. Miller capacitance,  $C_{MILLER}$ , can be approximated from the gate charge curve usually provided on the MOSFET manufacturers' data sheet.  $C_{MILLER}$  is equal to the increase in gate charge along the horizontal axis while the curve is approximately flat divided by the specified change in  $V_{DS}$ . This result is then multiplied by the ratio of the application applied  $V_{DS}$  to the gate charge curve specified  $V_{DS}$ . When the IC is operating in continuous mode, the duty cycles for the top and bottom MOSFETs are given by:

$$\text{Main Switch Duty Cycle} = \frac{V_{OUT}}{V_{IN}}$$

$$\text{Synchronous Switch Duty Cycle} = \frac{V_{IN} - V_{OUT}}{V_{IN}}$$

The MOSFET power dissipations at maximum output current are given by:

$$P_{MAIN} = \frac{V_{OUT}}{V_{IN}} (I_{MAX})^2 (1 + \delta) R_{DS(ON)} + (V_{IN})^2 \left( \frac{I_{MAX}}{2} \right) (R_{DR}) (C_{MILLER}) \cdot \left[ \frac{1}{V_{INTVCC} - V_{TH(MIN)}} + \frac{1}{V_{TH(MIN)}} \right] (f)$$

$$P_{SYNC} = \frac{V_{IN} - V_{OUT}}{V_{IN}} (I_{MAX})^2 (1 + \delta) R_{DS(ON)}$$

where  $\delta$  is the temperature dependency of  $R_{DS(ON)}$  and  $R_{DR}$  (approximately  $2\Omega$ ) is the effective driver resistance at the MOSFET's Miller threshold voltage.  $V_{TH(MIN)}$  is the typical MOSFET minimum threshold voltage.

Both MOSFETs have  $I^2R$  losses while the topside N-channel equation includes an additional term for transition losses, which are highest at high input voltages. For  $V_{IN} < 20V$ , the high current efficiency generally improves with larger MOSFETs, while for  $V_{IN} > 20V$ , the transition losses rapidly increase to the point that the use of a higher  $R_{DS(ON)}$  device with lower  $C_{MILLER}$  actually provides higher efficiency. The synchronous MOSFET losses are greatest at high input voltage when the top switch duty factor is low or during short-circuit when the synchronous switch is on close to 100% of the period.

The term  $(1 + \delta)$  is generally given for a MOSFET in the form of a normalized  $R_{DS(ON)}$  vs Temperature curve, but  $\delta = 0.005/^\circ C$  can be used as an approximation for low voltage MOSFETs.

The optional Schottky diode conducts during the dead time between the conduction of the two power MOSFETs. This prevents the body diode of the bottom MOSFET from turning on, storing charge during the dead time and requiring a reverse recovery period that could cost as much as 3% in efficiency at high  $V_{IN}$ . A 1A to 3A Schottky is generally a good size due to the relatively small average current. Larger diodes result in additional transition losses due to their larger junction capacitance.

### Soft-Start and Tracking

The LTC3851-1 has the ability to either soft-start by itself with a capacitor or track the output of another channel or external supply. When the LTC3851-1 is configured to soft-start by itself, a capacitor should be connected to the TK/SS pin. The LTC3851-1 is in the shutdown state if the RUN pin voltage is below 1.25V. TK/SS pin is actively pulled to ground in this shutdown state.

Once the RUN pin voltage is above 1.25V, the LTC3851-1 powers up. A soft-start current of  $1\mu A$  then starts to charge its soft-start capacitor. Note that soft-start or tracking is achieved not by limiting the maximum output current of the controller but by controlling the output ramp voltage according to the ramp rate on the TK/SS pin. Current foldback is disabled during this phase to ensure smooth soft-start or tracking. The soft-start or tracking range is

## APPLICATIONS INFORMATION

0V to 0.8V on the TK/SS pin. The total soft-start time can be calculated as:

$$t_{\text{SOFT-START}} = 0.8 \cdot \frac{C_{\text{SS}}}{1.0\mu\text{A}}$$

Regardless of the mode selected by the MODE/PLLIN pin, the regulator will always start in pulse skipping mode up to TK/SS = 0.64V. Between TK/SS = 0.64V and 0.72V, it will operate in forced continuous mode and revert to the selected mode once TK/SS > 0.72V. The output ripple is minimized during the 80mV forced continuous mode window.

When the regulator is configured to track another supply, the feedback voltage of the other supply is duplicated by a resistor divider and applied to the TK/SS pin. Therefore, the voltage ramp rate on this pin is determined by the ramp rate of the other supply's voltage. Note that the small soft-start capacitor charging current is always flowing, producing a small offset error. To minimize this error, one can select the tracking resistive divider value to be small enough to make this error negligible.

In order to track down another supply after the soft-start phase expires, the LTC3851-1 must be configured for forced continuous operation by connecting MODE/PLLIN to INTV<sub>CC</sub>.

### Output Voltage Tracking

The LTC3851-1 allows the user to program how its output ramps up and down by means of the TK/SS pins. Through this pin, the output can be set up to either coincidentally or ratiometrically track with another supply's output, as shown in Figure 3. In the following discussions, V<sub>MASTER</sub> refers to a master supply and V<sub>OUT</sub> refers to the LTC3851-1's output as a slave supply. To implement the coincident tracking in Figure 3a, connect a resistor divider to V<sub>MASTER</sub> and connect its midpoint to the TK/SS pin of the LTC3851-1. The ratio of this divider should be selected the same as that of the LTC3851-1's feedback divider as shown in Figure 4a. In this tracking mode, V<sub>MASTER</sub> must be higher than V<sub>OUT</sub>. To implement ratiometric tracking, the ratio of the resistor divider connected to V<sub>MASTER</sub> is determined by:

$$\frac{V_{\text{OUT}}}{V_{\text{MASTER}}} = \frac{R_2}{R_4} \left( \frac{R_3 + R_4}{R_1 + R_2} \right)$$

So which mode should be programmed? While either mode in Figure 4 satisfies most practical applications, the coincident mode offers better output regulation. This concept can be better understood with the help of Figure 5. At the input stage of the LTC3851-1's error amplifier, two common anode diodes are used to clamp the equivalent reference voltage and an additional diode

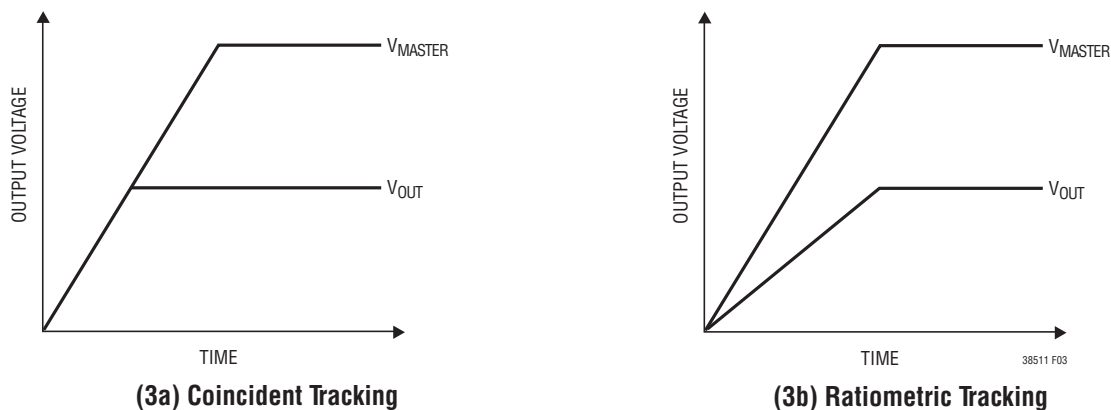

Figure 3. Two Different Modes of Output Voltage Tracking

## APPLICATIONS INFORMATION

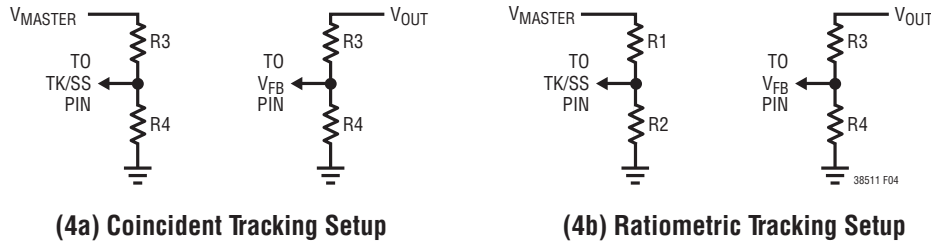

Figure 4. Setup for Coincident and Ratiometric Tracking

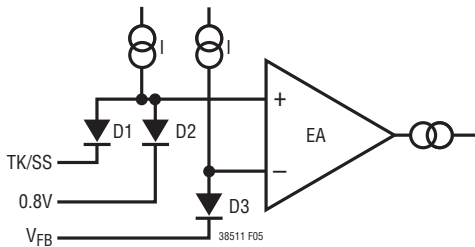

Figure 5. Equivalent Input Circuit of Error Amplifier

is used to match the shifted common mode voltage. The top two current sources are of the same amplitude. In the coincident mode, the TK/SS voltage is substantially higher than 0.8V at steady-state and effectively turns off D1. D2 and D3 will therefore conduct the same current and offer tight matching between  $V_{FB}$  and the internal precision 0.8V reference. In the ratiometric mode, however, TK/SS equals 0.8V at steady-state. D1 will divert part of the bias current to make  $V_{FB}$  slightly lower than 0.8V.

Although this error is minimized by the exponential I-V characteristic of the diode, it does impose a finite amount of output voltage deviation. Furthermore, when the master supply's output experiences dynamic excursion (under load transient, for example), the slave channel output will be affected as well. For better output regulation, use the coincident tracking mode instead of ratiometric.

### INTV<sub>CC</sub> Regulator

The LTC3851-1 features a PMOS low dropout linear regulator (LDO) that supplies power to INTV<sub>CC</sub> from the  $V_{IN}$  supply. INTV<sub>CC</sub> powers the gate drivers and much of the LTC3851-1's internal circuitry. The LDO regulates the voltage at the INTV<sub>CC</sub> pin to 5V.

The LDO can supply a peak current of 50mA and must be bypassed to ground with a minimum of 2.2 $\mu$ F ceramic capacitor or low ESR electrolytic capacitor. No matter what type of bulk capacitor is used, an additional 0.1 $\mu$ F ceramic capacitor placed directly adjacent to the INTV<sub>CC</sub> and GND pins is highly recommended. Good bypassing is needed to supply the high transient currents required by the MOSFET gate drivers.

High input voltage applications in which large MOSFETs are being driven at high frequencies may cause the maximum junction temperature rating for the LTC3851-1 to be exceeded. The INTV<sub>CC</sub> current, which is dominated by the gate charge current, is supplied by the 5V LDO.

Power dissipation for the IC in this case is highest and is approximately equal to  $V_{IN} \cdot I_{INTVCC}$ . The gate charge current is dependent on operating frequency as discussed in the Efficiency Considerations section. The junction temperature can be estimated by using the equations given in Note 3 of the Electrical Characteristics. For example, the LTC3851-1 INTV<sub>CC</sub> current is limited to less than 17mA from a 36V supply in the GN package:

$$T_J = 70^\circ\text{C} + (17\text{mA})(36\text{V})(90^\circ\text{C/W}) = 125^\circ\text{C}$$

To prevent the maximum junction temperature from being exceeded, the input supply current must be checked while operating in continuous conduction mode (MODE/PLLIN = INTV<sub>CC</sub>) at maximum  $V_{IN}$ .

### Topside MOSFET Driver Supply ( $C_B$ , $D_B$ )

An external bootstrap capacitor  $C_B$  connected to the BOOST pin supplies the gate drive voltage for the topside MOSFET. Capacitor  $C_B$  in the Functional Diagram is charged though external diode  $D_B$  from INTV<sub>CC</sub> when the SW pin

## APPLICATIONS INFORMATION

is low. When the topside MOSFET is to be turned on, the driver places the  $C_B$  voltage across the gate source of the MOSFET. This enhances the MOSFET and turns on the topside switch. The switch node voltage, SW, rises to  $V_{IN}$  and the BOOST pin follows. With the topside MOSFET on, the boost voltage is above the input supply:

$$V_{BOOST} = V_{IN} + V_{INTVCC}$$

The value of the boost capacitor  $C_B$  needs to be 100 times that of the total input capacitance of the topside MOSFET. The reverse breakdown of the external Schottky diode must be greater than  $V_{IN(MAX)}$ .

### Undervoltage Lockout

The LTC3851-1 has two functions that help protect the controller in case of undervoltage conditions. A precision UVLO comparator constantly monitors the  $INTV_{CC}$  voltage to ensure that an adequate gate-drive voltage is present. It locks out the switching action when  $INTV_{CC}$  is below 3.2V. To prevent oscillation when there is a disturbance on the  $INTV_{CC}$ , the UVLO comparator has 400mV of precision hysteresis.

Another way to detect an undervoltage condition is to monitor the  $V_{IN}$  supply. Because the RUN pin has a precision turn-on reference of 1.25V, one can use a resistor divider to  $V_{IN}$  to turn on the IC when  $V_{IN}$  is high enough.

### $C_{IN}$ Selection

In continuous mode, the source current of the top N-channel MOSFET is a square wave of duty cycle  $V_{OUT}/V_{IN}$ . To prevent large voltage transients, a low ESR input capacitor sized for the maximum RMS current must be used. The maximum RMS capacitor current is given by:

$$I_{RMS} \cong I_{O(MAX)} \frac{V_{OUT}}{V_{IN}} \left( \frac{V_{IN}}{V_{OUT}} - 1 \right)^{1/2}$$

This formula has a maximum at  $V_{IN} = 2V_{OUT}$ , where  $I_{RMS} = I_{O(MAX)}/2$ . This simple worst-case condition is commonly used for design because even significant deviations do not offer much relief. Note that capacitor manufacturers' ripple current ratings are often based on only 2000 hours of life. This makes it advisable to further derate the capacitor or to choose a capacitor rated at a higher temperature than

required. Several capacitors may also be paralleled to meet size or height requirements in the design. Always consult the manufacturer if there is any question.

### $C_{OUT}$ Selection

The selection of  $C_{OUT}$  is primarily determined by the effective series resistance, ESR, to minimize voltage ripple. The output ripple,  $\Delta V_{OUT}$ , in continuous mode is determined by:

$$\Delta V_{OUT} \approx \Delta I_L \left( ESR + \frac{1}{8fC_{OUT}} \right)$$

where  $f$  = operating frequency,  $C_{OUT}$  = output capacitance and  $\Delta I_L$  = ripple current in the inductor. The output ripple is highest at maximum input voltage since  $\Delta I_L$  increases with input voltage. Typically, once the ESR requirement for  $C_{OUT}$  has been met, the RMS current rating generally far exceeds the  $I_{RIPPLE(P-P)}$  requirement. With  $\Delta I_L = 0.3I_{OUT(MAX)}$  and allowing 2/3 of the ripple to be due to ESR, the output ripple will be less than 50mV at maximum  $V_{IN}$  and:

$$C_{OUT} \text{ Required ESR} < 2.2R_{SENSE}$$

$$C_{OUT} > \frac{1}{8fR_{SENSE}}$$

The first condition relates to the ripple current into the ESR of the output capacitance while the second term guarantees that the output capacitance does not significantly discharge during the operating frequency period due to ripple current. The choice of using smaller output capacitance increases the ripple voltage due to the discharging term but can be compensated for by using capacitors of very low ESR to maintain the ripple voltage at or below 50mV. The  $I_{TH}$  pin OPTI-LOOP compensation components can be optimized to provide stable, high performance transient response regardless of the output capacitors selected.

The selection of output capacitors for applications with large load current transients is primarily determined by the voltage tolerance specifications of the load. The resistive component of the capacitor, ESR, multiplied by the load current change, plus any output voltage ripple must be within the voltage tolerance of the load.

## APPLICATIONS INFORMATION

The required ESR due to a load current step is:

$$R_{\text{ESR}} \leq \frac{\Delta V}{\Delta I}$$

where  $\Delta I$  is the change in current from full load to zero load (or minimum load) and  $\Delta V$  is the allowed voltage deviation (not including any droop due to finite capacitance).

The amount of capacitance needed is determined by the maximum energy stored in the inductor. The capacitance must be sufficient to absorb the change in inductor current when a high current to low current transition occurs. The opposite load current transition is generally determined by the control loop OPTI-LOOP components, so make sure not to over compensate and slow down the response. The minimum capacitance to assure the inductors' energy is adequately absorbed is:

$$C_{\text{OUT}} > \frac{L(\Delta I)^2}{2(\Delta V)V_{\text{OUT}}}$$

where  $\Delta I$  is the change in load current.

Manufacturers such as Nichicon, United Chemi-Con and Sanyo can be considered for high performance through-hole capacitors. The OS-CON semiconductor electrolyte capacitor available from Sanyo has the lowest (ESR)(size) product of any aluminum electrolytic at a somewhat higher price. An additional ceramic capacitor in parallel with OS-CON capacitors is recommended to reduce the inductance effects.

In surface mount applications, ESR, RMS current handling and load step specifications may require multiple capacitors in parallel. Aluminum electrolytic, dry tantalum and special polymer capacitors are available in surface mount packages. Special polymer surface mount capacitors offer very low ESR but have much lower capacitive density per unit volume than other capacitor types. These capacitors offer a very cost-effective output capacitor solution and are an ideal choice when combined with a controller having high loop bandwidth. Tantalum capacitors offer the highest capacitance density and are often used as output capacitors for switching regulators having controlled soft-start. Several excellent surge-tested choices are the AVX TPS,

AVX TPSV or the KEMET T510 series of surface mount tantalums, available in case heights ranging from 1.5mm to 4.1mm. Aluminum electrolytic capacitors can be used in cost-driven applications, provided that consideration is given to ripple current ratings, temperature and long-term reliability. A typical application will require several to many aluminum electrolytic capacitors in parallel. A combination of the above mentioned capacitors will often result in maximizing performance and minimizing overall cost. Other capacitor types include Nichicon PL series, NEC Neocap, Panasonic SP and Sprague 595D series. Consult manufacturers for other specific recommendations.

Like all components, capacitors are not ideal. Each capacitor has its own benefits and limitations. Combinations of different capacitor types have proven to be a very cost effective solution. Remember also to include high frequency decoupling capacitors. They should be placed as close as possible to the power pins of the load. Any inductance present in the circuit board traces negates their usefulness.

### Setting Output Voltage

The LTC3851-1 output voltage is set by an external feedback resistive divider carefully placed across the output, as shown in Figure 6. The regulated output voltage is determined by:

$$V_{\text{OUT}} = 0.8V \left( 1 + \frac{R_{\text{B}}}{R_{\text{A}}} \right)$$

To improve the transient response, a feed-forward capacitor,  $C_{\text{FF}}$ , may be used. Great care should be taken to route the  $V_{\text{FB}}$  line away from noise sources, such as the inductor or the SW line.

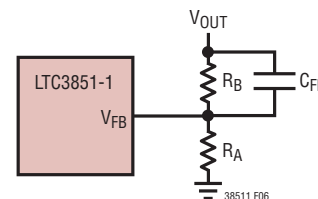

Figure 6. Settling Output Voltage

## APPLICATIONS INFORMATION

### Fault Conditions: Current Limit and Current Foldback

The LTC3851-1 includes current foldback to help limit load current when the output is shorted to ground. If the output falls below 40% of its nominal output level, the maximum sense voltage is progressively lowered from its maximum programmed value to about 25% of the that value. Foldback current limiting is disabled during soft-start or tracking. Under short-circuit conditions with very low duty cycles, the LTC3851-1 will begin cycle skipping in order to limit the short-circuit current. In this situation the bottom MOSFET will be dissipating most of the power but less than in normal operation. The short-circuit ripple current is determined by the minimum on-time  $t_{ON(MIN)}$  of the LTC3851-1 ( $\approx 90\text{ns}$ ), the input voltage and inductor value:

$$\Delta I_{L(SC)} = t_{ON(MIN)} \cdot \frac{V_{IN}}{L}$$

The resulting short-circuit current is:

$$I_{SC} = \frac{1/4 \text{Max} V_{SENSE}}{R_{SENSE}} - \frac{1}{2} \Delta I_{L(SC)}$$

### Programming Switching Frequency

To set the switching frequency of the LTC3851-1, connect a resistor,  $R_{FREQ}$ , between  $FREQ/PLLFLTR$  and GND. The relationship between the oscillator frequency and  $R_{FREQ}$  is shown in Figure 7. A  $0.1\mu\text{F}$  bypass capacitor should be connected in parallel with  $R_{FREQ}$ .

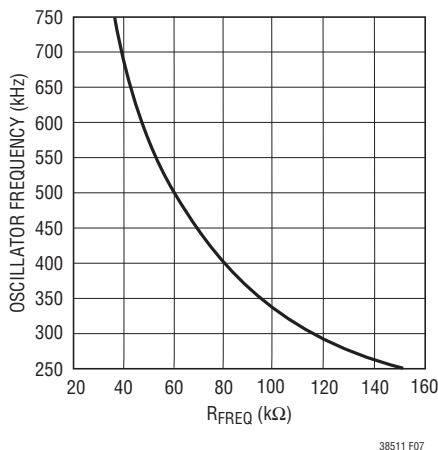

38511 F07

Figure 7. Relationship Between Oscillator Frequency and Resistor Connected Between  $FREQ/PLLFLTR$  and GND

### Phase-Locked Loop and Frequency Synchronization

The LTC3851-1 has a phase-locked loop (PLL) comprised of an internal voltage-controlled oscillator ( $V_{CO}$ ) and a phase detector. This allows the turn-on of the top MOSFET to be locked to the rising edge of an external clock signal applied to the  $MODE/PLLIN$  pin. This phase detector is an edge sensitive digital type that provides zero degrees phase shift between the external and internal oscillators. This type of phase detector does not exhibit false lock to harmonics of the external clock.

The output of the phase detector is a pair of complementary current sources that charge or discharge the external filter network connected to the  $FREQ/PLLFLTR$  pin. Note that the LTC3851-1 can only be synchronized to an external clock whose frequency is within range of the LTC3851-1's internal  $V_{CO}$ . This is guaranteed to be between 250kHz and 750kHz. A simplified block diagram is shown in Figure 8.

If the external clock frequency is greater than the internal oscillator's frequency,  $f_{OSC}$ , then current is sunk continuously from the phase detector output, pulling down the  $FREQ/PLLFLTR$  pin. When the external clock frequency is less than  $f_{OSC}$ , current is sourced continuously, pulling up the  $FREQ/PLLFLTR$  pin. If the external and internal frequencies are the same but exhibit a phase difference, the current sources turn on for an amount of time corresponding to the phase difference. The voltage on the  $FREQ/PLLFLTR$  pin is adjusted until the phase and frequency of the internal and external oscillators are identical. At the stable operating point, the phase detector output is high impedance and the filter capacitor  $C_{LP}$  holds the voltage.

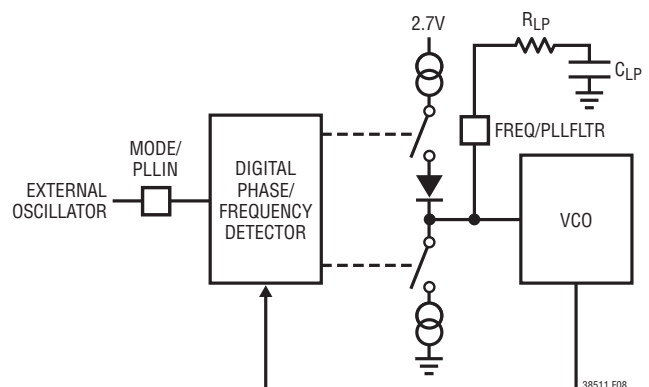

38511 F08

Figure 8. Phase-Locked Loop Block Diagram

38511fa

## APPLICATIONS INFORMATION

The loop filter components,  $C_{LP}$  and  $R_{LP}$ , smooth out the current pulses from the phase detector and provide a stable input to the voltage-controlled oscillator. The filter components  $C_{LP}$  and  $R_{LP}$  determine how fast the loop acquires lock. Typically  $R_{LP}$  is 1k to 10k and  $C_{LP}$  is 2200pF to 0.01 $\mu$ F.

When the external oscillator is active before the LTC3851 is enabled, the internal oscillator frequency will track the external oscillator frequency as described in the preceding paragraphs. In situations where the LTC3851 is enabled before the external oscillator is active, a low free-running oscillator frequency of approximately 50kHz will result. It is possible to increase the free-running, pre-synchronization frequency by adding a second resistor in parallel with  $R_{LP}$  and  $C_{LP}$ . The second resistor will also cause a phase difference between the internal and external oscillator signals. The magnitude of the phase difference is inversely proportional to the value of the second resistor.

The external clock (on MODE/PLLIN pin) input high threshold is nominally 1.6V, while the input low threshold is nominally 1.2V.

### Minimum On-Time Considerations

Minimum on-time  $t_{ON(MIN)}$  is the smallest time duration that the LTC3851-1 is capable of turning on the top MOSFET. It is determined by internal timing delays and the gate charge required to turn on the top MOSFET. Low duty cycle applications may approach this minimum on-time limit and care should be taken to ensure that:

$$t_{ON(MIN)} < \frac{V_{OUT}}{V_{IN}(f)}$$

If the duty cycle falls below what can be accommodated by the minimum on-time, the controller will begin to skip cycles. The output voltage will continue to be regulated, but the ripple voltage and current will increase.

The minimum on-time for the LTC3851-1 is approximately 90ns. However, as the peak sense voltage decreases the minimum on-time gradually increases. This is of particular concern in forced continuous applications with low ripple current at light loads. If the duty cycle drops below the minimum on-time limit in this situation, a significant

amount of cycle skipping can occur with correspondingly larger current and voltage ripple.

### Efficiency Considerations

The percent efficiency of a switching regulator is equal to the output power divided by the input power times 100%. It is often useful to analyze individual losses to determine what is limiting the efficiency and which change would produce the most improvement. Percent efficiency can be expressed as:

$$\% \text{Efficiency} = 100\% - (L1 + L2 + L3 + \dots)$$

where L1, L2, etc. are the individual losses as a percentage of input power.

Although all dissipative elements in the circuit produce losses, four main sources usually account for most of the losses in LTC3851-1 circuits: 1) IC  $V_{IN}$  current, 2)  $INTV_{CC}$  regulator current, 3)  $I^2R$  losses, 4) topside MOSFET transition losses.

1. The  $V_{IN}$  current is the DC supply current given in the Electrical Characteristics table, which excludes MOSFET driver current.  $V_{IN}$  current typically results in a small (<0.1%) loss.
2.  $INTV_{CC}$  current is the sum of the MOSFET driver and control currents. The MOSFET driver current results from switching the gate capacitance of the power MOSFETs. Each time a MOSFET gate is switched from low to high to low again, a packet of charge  $dQ$  moves from  $INTV_{CC}$  to ground. The resulting  $dQ/dt$  is a current out of  $INTV_{CC}$  that is typically much larger than the control circuit current. In continuous mode,  $I_{GATECHG} = f(Q_T + Q_B)$ , where  $Q_T$  and  $Q_B$  are the gate charges of the topside and bottom side MOSFETs.
3.  $I^2R$  losses are predicted from the DC resistances of the fuse (if used), MOSFET, inductor and current sense resistor. In continuous mode, the average output current flows through L and  $R_{SENSE}$ , but is "chopped" between the topside MOSFET and the synchronous MOSFET. If the two MOSFETs have approximately the same  $R_{DS(ON)}$ , then the resistance of one MOSFET can simply be summed with the resistances of L and  $R_{SENSE}$  to obtain  $I^2R$  losses. For example, if each  $R_{DS(ON)} = 10m\Omega$ ,

## APPLICATIONS INFORMATION

$DCR = 10m\Omega$  and  $R_{SENSE} = 5m\Omega$ , then the total resistance is  $25m\Omega$ . This results in losses ranging from 2% to 8% as the output current increases from 3A to 15A for a 5V output, or a 3% to 12% loss for a 3.3V output. Efficiency varies as the inverse square of  $V_{OUT}$  for the same external components and output power level. The combined effects of increasingly lower output voltages and higher currents required by high performance digital systems is not doubling but quadrupling the importance of loss terms in the switching regulator system!

4. Transition losses apply only to the topside MOSFET(s), and become significant only when operating at high input voltages (typically 15V or greater). Transition losses can be estimated from:

$$\text{Transition Loss} = (1.7)V_{IN}^2 \cdot I_{O(MAX)} \cdot C_{RSS} \cdot f$$

Other “hidden” losses such as copper trace and the battery internal resistance can account for an additional 5% to 10% efficiency degradation in portable systems. It is very important to include these “system” level losses during the design phase. The internal battery and fuse resistance losses can be minimized by making sure that  $C_{IN}$  has adequate charge storage and very low ESR at the switching frequency. A 25W supply will typically require a minimum of  $20\mu F$  to  $40\mu F$  of capacitance having a maximum of  $20m\Omega$  to  $50m\Omega$  of ESR. Other losses including Schottky conduction losses during dead time and inductor core losses generally account for less than 2% total additional loss.

### Checking Transient Response

The regulator loop response can be checked by looking at the load current transient response. Switching regulators take several cycles to respond to a step in DC (resistive) load current. When a load step occurs,  $V_{OUT}$  shifts by an amount equal to  $\Delta I_{LOAD}$  (ESR), where ESR is the effective series resistance of  $C_{OUT}$ .  $\Delta I_{LOAD}$  also begins to charge or discharge  $C_{OUT}$  generating the feedback error signal that forces the regulator to adapt to the current change and return  $V_{OUT}$  to its steady-state value. During this recovery time  $V_{OUT}$  can be monitored for excessive overshoot or ringing, which would indicate a stability problem. The availability of the  $I_{TH}$  pin not only allows optimization of

control loop behavior but also provides a DC coupled and AC filtered closed-loop response test point. The DC step, rise time and settling at this test point truly reflects the closed-loop response. Assuming a predominantly second order system, phase margin and/or damping factor can be estimated using the percentage of overshoot seen at this pin. The bandwidth can also be estimated by examining the rise time at the pin. The  $I_{TH}$  external components shown in the Typical Application circuit will provide an adequate starting point for most applications.

The  $I_{TH}$  series  $R_C$ - $C_C$  filter sets the dominant pole-zero loop compensation. The values can be modified slightly (from 0.5 to 2 times their suggested values) to optimize transient response once the final PC layout is done and the particular output capacitor type and value have been determined. The output capacitors need to be selected because the various types and values determine the loop gain and phase. An output current pulse of 20% to 80% of full-load current having a rise time of  $1\mu s$  to  $10\mu s$  will produce output voltage and  $I_{TH}$  pin waveforms that will give a sense of the overall loop stability without breaking the feedback loop. Placing a power MOSFET directly across the output capacitor and driving the gate with an appropriate signal generator is a practical way to produce a realistic load step condition. The initial output voltage step resulting from the step change in output current may not be within the bandwidth of the feedback loop, so this signal cannot be used to determine phase margin. This is why it is better to look at the  $I_{TH}$  pin signal which is in the feedback loop and is the filtered and compensated control loop response. The midband gain of the loop will be increased by increasing  $R_C$  and the bandwidth of the loop will be increased by decreasing  $C_C$ . If  $R_C$  is increased by the same factor that  $C_C$  is decreased, the zero frequency will be kept the same, thereby keeping the phase shift the same in the most critical frequency range of the feedback loop. The output voltage settling behavior is related to the stability of the closed-loop system and will demonstrate the actual overall supply performance.

A second, more severe transient is caused by switching in loads with large ( $>1\mu F$ ) supply bypass capacitors. The discharged bypass capacitors are effectively put in parallel with  $C_{OUT}$ , causing a rapid drop in  $V_{OUT}$ . No regulator can



## APPLICATIONS INFORMATION

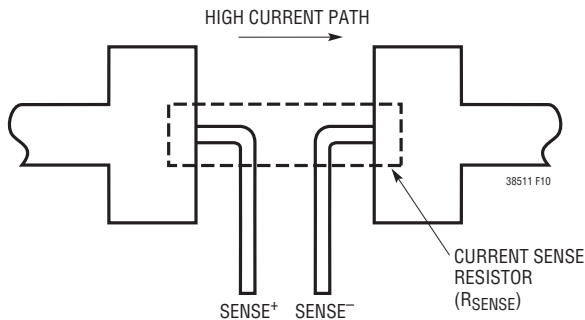

Figure 10. Kelvin Sensing  $R_{SENSE}$

- Does the (+) terminal of  $C_{IN}$  connect to the drain of the topside MOSFET(s) as closely as possible? This capacitor provides the AC current to the MOSFET(s).
- Is the  $INTV_{CC}$  decoupling capacitor connected closely between  $INTV_{CC}$  and GND? This capacitor carries the MOSFET driver peak currents. An additional  $1\mu\text{F}$  ceramic capacitor placed immediately next to the  $INTV_{CC}$  and GND pins can help improve noise performance.
- Keep the switching node (SW), top gate node (TG) and boost node (BOOST) away from sensitive small-signal nodes, especially from the voltage and current sensing feedback pins. All of these nodes have very large and fast moving signals and therefore should be kept on the “output side” (Pin 9 to Pin 16) of the LTC3851-1 and occupy minimum PC trace area.

### PC Board Layout Debugging

It is helpful to use a DC-50MHz current probe to monitor the current in the inductor while testing the circuit. Monitor the output switching node (SW pin) to synchronize the oscilloscope to the internal oscillator and probe the actual output voltage as well. Check for proper performance over the operating voltage and current range expected in the application. The frequency of operation should be maintained over the input voltage range down to dropout and until the output load drops below the low current operation threshold—typically 10% of the maximum designed current level in Burst Mode operation.

The duty cycle percentage should be maintained from cycle to cycle in a well designed, low noise PCB implementation. Variation in the duty cycle at a subharmonic rate can suggest noise pick-up at the current or voltage sensing inputs or inadequate loop compensation. Overcompensation of the loop can be used to tame a poor PC layout if regulator bandwidth optimization is not required.

Reduce  $V_{IN}$  from its nominal level to verify operation of the regulator in dropout. Check the operation of the undervoltage lockout circuit by further lowering  $V_{IN}$  while monitoring the outputs to verify operation.

Investigate whether any problems exist only at higher output currents or only at higher input voltages. If problems coincide with high input voltages and low output currents, look for capacitive coupling between the BOOST, SW, TG and possibly BG connections and the sensitive voltage and current pins. The capacitor placed across the current sensing pins needs to be placed immediately adjacent to the pins of the IC. This capacitor helps to minimize the effects of differential noise injection due to high frequency capacitive coupling. If problems are encountered with high current output loading at lower input voltages, look for inductive coupling between  $C_{IN}$ , the Schottky and the top MOSFET to the sensitive current and voltage sensing traces. In addition, investigate common ground path voltage pickup between these components and the GND pin of the IC.

### Design Example

As a design example, assume  $V_{IN} = 12\text{V}$  (nominal),  $V_{IN} = 22\text{V}$  (maximum),  $V_{OUT} = 1.8\text{V}$ ,  $I_{MAX} = 5\text{A}$ , and  $f = 250\text{kHz}$  (refer to Figure 12).

The inductance value is chosen first based on a 30% ripple current assumption. The highest value of ripple current occurs at the maximum input voltage. Connect a 160k resistor between the  $FREQ/PLLFLTR$  and GND pins, generating 250kHz operation. The minimum inductance for 30% ripple current is:

$$\Delta I_L = \frac{1}{(f)(L)} V_{OUT} \left( 1 - \frac{V_{OUT}}{V_{IN}} \right)$$

## APPLICATIONS INFORMATION

A 4.7 $\mu$ H inductor will produce 28% ripple current and a 3.3 $\mu$ H will result in 40%. The peak inductor current will be the maximum DC value plus one-half the ripple current, or 6A, for the 3.3 $\mu$ H value. Increasing the ripple current will also help ensure that the minimum on-time of 90ns is not violated. The minimum on-time occurs at maximum  $V_{IN}$ :

$$t_{ON(MIN)} = \frac{V_{OUT}}{V_{IN(MAX)}(f)} = \frac{1.8V}{22V(250kHz)} = 327ns$$

The  $R_{SENSE}$  resistor value can be calculated by using the maximum current sense voltage specification with some accommodation for tolerances.

$$R_{SENSE} \leq \frac{50mV}{6A} = 0.0083\Omega$$

Choosing 1% resistors:  $R1 = 25.5k$  and  $R2 = 32.4k$  yields an output voltage of 1.816V.

The power dissipation on the topside MOSFET can be easily estimated. Choosing a Fairchild FDS6982S dual MOSFET results in:  $R_{DS(ON)} = 0.035\Omega/0.022\Omega$ ,  $C_{MILLER} = 215pF$ . At maximum input voltage with  $T$  (estimated) = 50°C:

$$P_{MAIN} = \frac{1.8V}{22V}(5)^2 [1 + (0.005)(50^\circ C - 25^\circ C)] \cdot \\ (0.035\Omega) + (22V)^2 \left(\frac{5A}{2}\right) (2\Omega)(215pF) \cdot \\ \left[\frac{1}{5 - 2.3} + \frac{1}{2.3}\right] (250kHz) = 185mW$$

A short-circuit to ground will result in a folded back current of:

$$I_{SC} = \frac{29mV}{0.0125\Omega} - \frac{1}{2} \left( \frac{90ns(22V)}{3.3\mu H} \right) = 2.02A$$

with a typical value of  $R_{DS(ON)}$  and  $\delta = (0.005/^\circ C)(25^\circ C) = 0.125$ . The resulting power dissipated in the bottom MOSFET is:

$$P_{SYNC} = \frac{22V}{22V} (2.02A)^2 (1.125)(0.022\Omega) = 101.0mW$$

which is less than under full-load conditions.

$C_{IN}$  is chosen for an RMS current rating of at least 3A at temperature.  $C_{OUT}$  is chosen with an ESR of 0.02 $\Omega$  for low output ripple. The output ripple in continuous mode will be highest at the maximum input voltage. The output voltage ripple due to ESR is approximately:

$$V_{ORIPPLE} = R_{ESR} (\Delta I_L) = 0.02\Omega (2A) = 40mV_{P-P}$$



## TYPICAL APPLICATIONS

1.5V/15A Synchronized at 350kHz

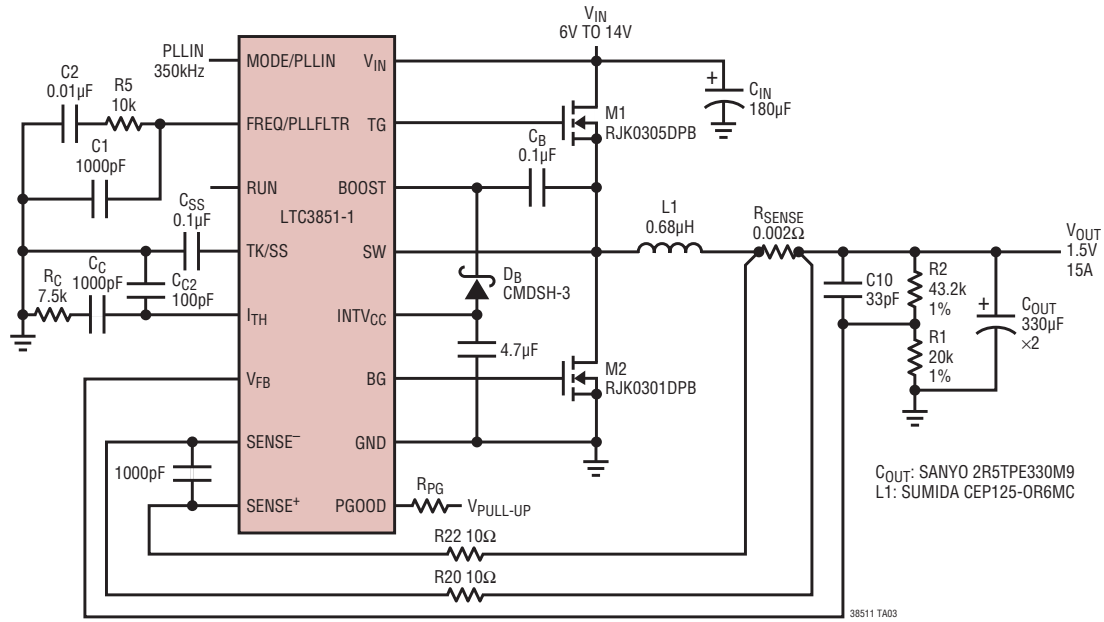

# PACKAGE DESCRIPTION

## MSE Package 16-Lead Plastic MSOP, Exposed Die Pad (Reference LTC DWG # 05-08-1667 Rev A)

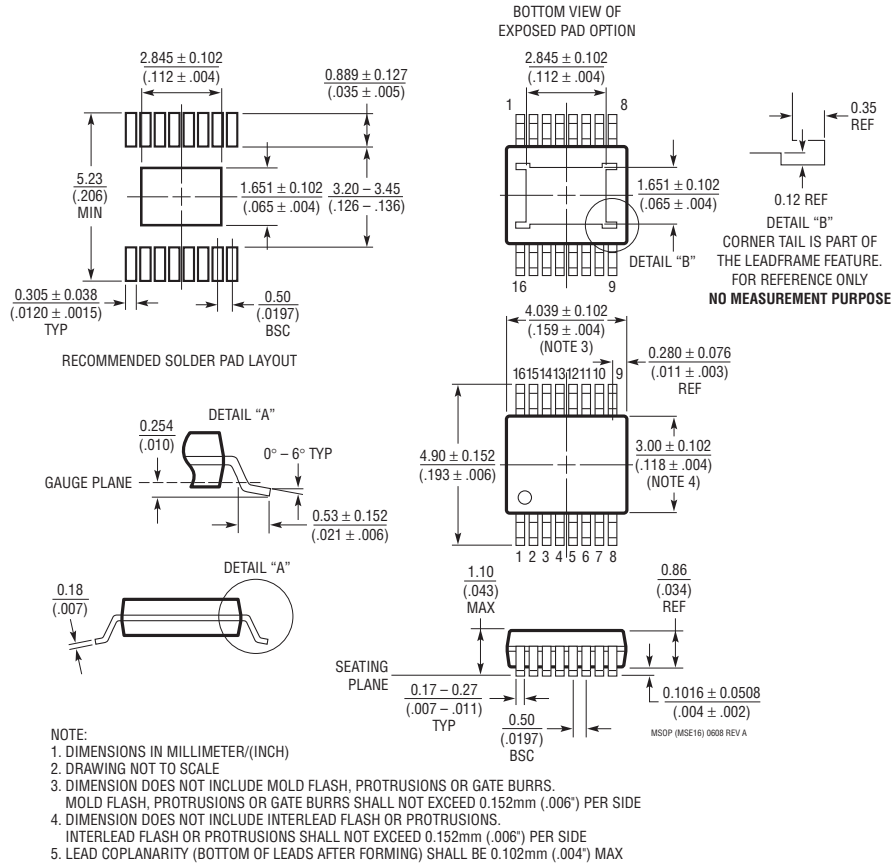

## UD Package 16-Lead Plastic QFN (3mm × 3mm) (Reference LTC DWG # 05-08-1691)

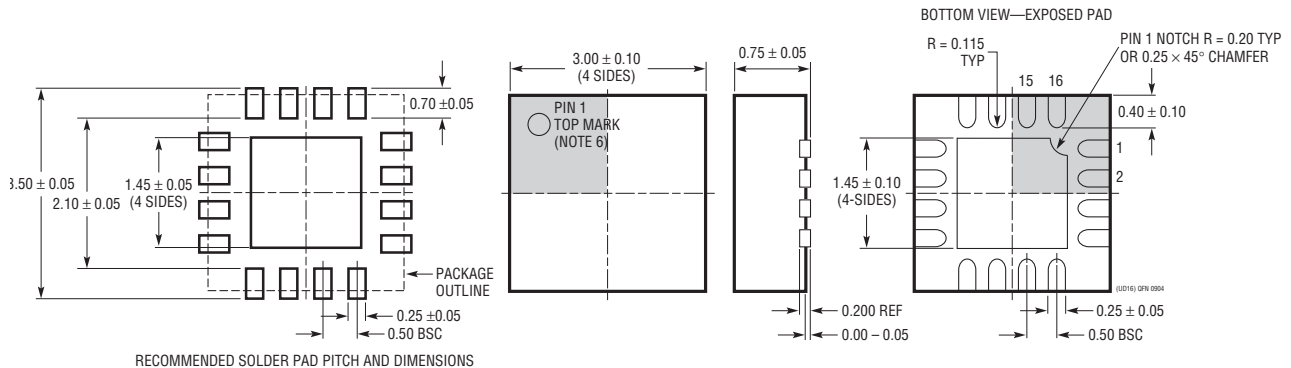

## RELATED PARTS

PART NUMBER	DESCRIPTION	COMMENTS
LTC1625/LTC1775	No R <sub>SENSE</sub> <sup>TM</sup> Current Mode Synchronous Step-Down Controllers	97% Efficiency, No Sense Resistor, 16-Pin SSOP
LTC1735	High Efficiency Synchronous Step-Down Switching Regulator	Output Fault Protection, 16-Pin SSOP
LTC1778	No R <sub>SENSE</sub> Wide Input Range Synchronous Step-Down Controller	Up to 97% Efficiency, $4V \leq V_{IN} \leq 36V$ , $0.8V \leq V_{OUT} \leq (0.9)(V_{IN})$ , I <sub>OUT</sub> Up to 20A
LT <sup>®</sup> 3724	Low I <sub>Q</sub> High Voltage Current Mode Switching Regulator Controller	V <sub>IN</sub> up to 60V, I <sub>OUT</sub> ≤ 5A, 16-Lead TSSOP FE Package, 100μA I <sub>Q</sub> , Onboard Bias Regulator, Burst Mode Operation, 200kHz Operation
LTC3727A-1	Dual, 2-Phase Synchronous Controller	Very Low Dropout, V <sub>OUT</sub> ≤ 14V
LTC3728	2-Phase 550kHz, Dual Synchronous Step-Down Controller	QFN and SSOP Packages, High Frequency for Smaller L and C
LTC3729L-6	20A to 200A PolyPhase <sup>®</sup> Synchronous Controller	Expandable from 2-Phase to 12-Phase, Uses All Surface Mount Components, No Heat Sink
LTC3731	3-Phase, 600kHz Synchronous Step-Down Controller	$0.6V \leq V_{OUT} \leq 6V$ , $4.5V \leq V_{IN} \leq 32V$ , I <sub>OUT</sub> ≤ 60A, Integrated MOSFET Drivers
LTC3773	Triple Output DC/DC Synchronous Controller	3-Phase Step-Down DC/DC Controller, $3.3V \leq V_{IN} \leq 36V$ , Fixed Frequency 160kHz to 700kHz
LT3800	Low I <sub>Q</sub> High Voltage Synchronous Regulator Controller	V <sub>IN</sub> up to 60V, I <sub>OUT</sub> ≤ 20A, Current Mode, Onboard Bias Regulator, 100μA I <sub>Q</sub> , Burst Mode Operation, 16-Lead TSSOP FE Package
LTC3810	100V Current Mode Nonisolated Switching Regulator Controller	$6.2V \leq V_{IN} \leq 100$ , $0.8V \leq V_{OUT} \leq 0.9V_{IN}$ , No R <sub>SENSE</sub> , Tracking and Synchronizable
LTC3811	Dual, PolyPhase Synchronous Step-Down Controller, 20A to 200A	Differential Remote Sense Amplifier, R <sub>SENSE</sub> or DCR Current Sense
LTC3824	Low I <sub>Q</sub> High Voltage 100% Duty Cycle Step-Down Controller	$4V \leq V_{IN} \leq 60V$ , $0.8V \leq V_{OUT} \leq V_{IN}$ , 40μA Quiescent Current, MSOP-10 Package
LTC3826/LTC3826-1	Low I <sub>Q</sub> Dual Synchronous Controllers	$4V \leq V_{IN} \leq 36V$ , $0.8V \leq V_{OUT} \leq 10V$ , 30μA Quiescent Current
LTC3834/LTC3834-1	Low I <sub>Q</sub> Synchronous Step-Down Controllers	Single Channel LTC3826/LTC3826-1
LTC3844	Low I <sub>Q</sub> High Voltage Current Mode Controller with Programmable Operating Frequency	V <sub>IN</sub> up to 60V, I <sub>OUT</sub> ≤ 5A, Onboard Bias Regulator, Burst Mode Operation, 120μA I <sub>Q</sub> , Sync Capability, 16-Lead TSSOP FE Package
LTC3845	Low I <sub>Q</sub> Synchronous Step-Down Controller	$4V \leq V_{IN} \leq 60V$ , $1.23V \leq V_{OUT} \leq 36V$ , 120μA Quiescent Current
LTC3850/LTC3850-1 LTC3850-2	Dual, 2-Phase Synchronous Step-Down Controllers	R <sub>SENSE</sub> or DCR Current Sensing, Tracking and Synchronizable
LTC3853	Triple Output, Multiphase Synchronous Step-Down Controller	R <sub>SENSE</sub> or DCR Current Sensing, Tracking and Synchronizable
LTM <sup>®</sup> 4600	10A Complete Switch Mode Power Supply	92% Efficiency, V <sub>IN</sub> : 4.5V to 28V, V <sub>OUT</sub> = 0.6V, True Current Mode Control, UltraFast <sup>TM</sup> Transient Response
LTM4601A	12A Complete Switch Mode Power Supply	92% Efficiency, V <sub>IN</sub> : 4.5V to 28V, V <sub>OUT</sub> = 0.6V, True Current Mode Control, UltraFast Transient Response
LTM8020	High V <sub>IN</sub> 0.2A DC/DC Step-Down μModule	$4V \leq V_{IN} \leq 36V$ , $1.25V \leq V_{OUT} \leq 5V$ , 6.25mm × 6.25mm × 2.3mm LGA Package
LTM8021	High V <sub>IN</sub> 0.5A DC/DC Step-Down μModule	$3V \leq V_{IN} \leq 36V$ , $0.8V \leq V_{OUT} \leq 5V$ , 6.25mm × 11.25mm × 2.8mm LGA Package
LTM8022/LTM8023	36V <sub>IN</sub> , 1A and 2A DC/DC μModule	Pin Compatible, $4.5V \leq V_{IN} \leq 36V$ , 9mm × 11.25mm × 2.8mm LGA Package

PolyPhase is a registered trademark of Linear Technology Corporation. No R<sub>SENSE</sub> and UltraFast are trademarks of Linear Technology Corporation.

## Looking for pricing, stock, or lifecycle information?

Click below to explore more details on WIN SOURCE:

- ⊖ [View LTC3851EMSE-1#TRPBF on WIN SOURCE](#)
- ⊖ [Linear Technology Information](#)

## Optimize Your Supply Chain with WIN SOURCE Solutions

- ✓ Global Sourcing Solution
- ✓ Obsolete Management
- ✓ Cost Control Management
- ✓ Shortage Management
- ✓ Alternative Solution
- ✓ Excess Inventory Management