



**THE DATASHEET OF
LTC4370IDE#PBF**



Two-Supply Diode-OR Current Balancing Controller

FEATURES

- Shares Load Between Two Supplies
- Eliminates Need for Active Control of Input Supplies
- No Share Bus Required
- Blocks Reverse Current
- No Shoot-Through Current During Start-Up or Faults
- 0V to 18V High Side Operation
- Enable Inputs
- MOSFET On Status Outputs
- Dual Ideal Diode Mode
- 16-Lead DFN (4mm × 3mm) and MSOP Packages

APPLICATIONS

- Redundant Power Supplies
- High Availability Systems and Servers
- Telecom and Network Infrastructure

LT, LT, LTC, LTM, Linear Technology and the Linear logo are registered trademarks and PowerPath and ThinSOT are trademarks of Linear Technology Corporation. All other trademarks are the property of their respective owners. Protected by U.S. Patents, including 7920013 and 8022679. Additional patent pending.

DESCRIPTION

The LTC[®]4370 is a two-supply current sharing controller which incorporates MOSFET ideal diodes. The diodes block reverse and shoot-through currents during start-up and fault conditions. Their forward voltage is adjusted to share the load currents between supplies. Unlike other sharing methods, neither a share bus nor trim pins on the supply are required.

The maximum MOSFET voltage drop can be set with a resistor. A fast gate turn-on reduces the load voltage droop during supply switchover. If the input supply fails or is shorted, a fast turn-off minimizes reverse current transients.

The controller operates with supplies from 2.9V to 18V. For lower rail voltages, an external supply is needed at the V_{CC} pin. Enable inputs can be used to turn off the MOSFET and put the controller in a low current state. Status outputs indicate whether the MOSFETs are on or off. The load sharing function can be disabled to turn the LTC4370 into a dual ideal diode controller.

TYPICAL APPLICATION

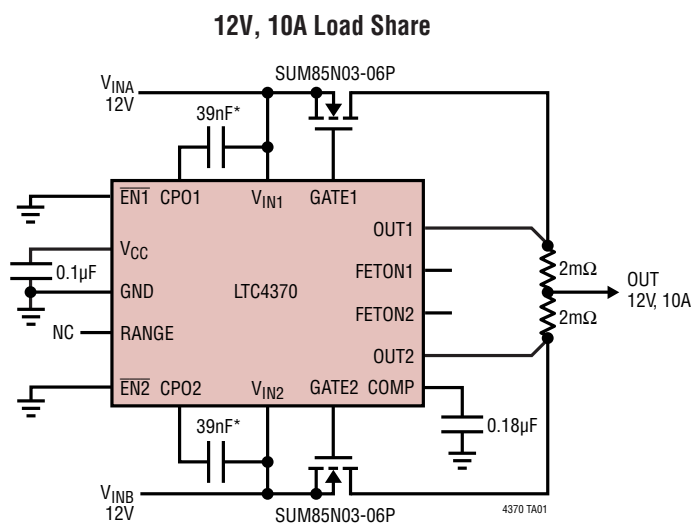

Current Sharing Error vs Supply Difference

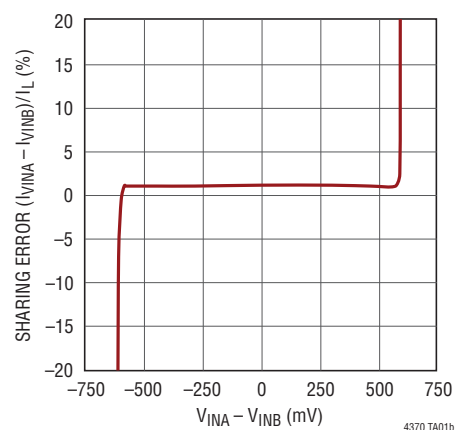

LTC4370

ABSOLUTE MAXIMUM RATINGS (Notes 1, 2)

V_{IN1} , V_{IN2} , OUT1, OUT2 Voltages	-2V to 24V	FETON1, FETON2 Currents.....	5mA
V_{CC} Voltage	-0.3V to 6.5V	Operating Ambient Temperature Range	
GATE1, GATE2 Voltages (Note 3)	-0.3V to 34V	LTC4370C	0°C to 70°C
CPO1, CPO2 Voltages (Note 3).....	-0.3V to 34V	LTC4370I	-40°C to 85°C
RANGE Voltage	-0.3V to $V_{CC} + 0.3V$	Storage Temperature Range	-65°C to 150°C
COMP Voltage.....	-0.3V to 3V	Lead Temperature (Soldering, 10 sec)	
$EN1$, $EN2$, FETON1, FETON2 Voltages	-0.3V to 24V	MS Package.....	300°C
CPO1, CPO2 Average Current.....	10mA		

PIN CONFIGURATION

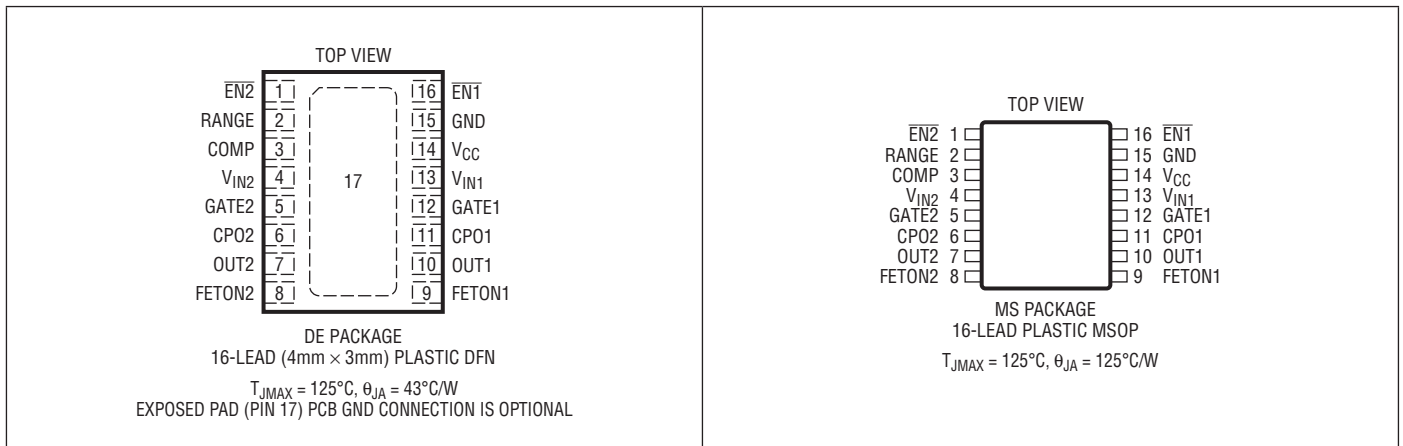

ORDER INFORMATION

LEAD FREE FINISH	TAPE AND REEL	PART MARKING*	PACKAGE DESCRIPTION	TEMPERATURE RANGE
LTC4370CDE#PBF	LTC4370CDE#TRPBF	4370	16-Lead (4mm × 3mm) Plastic DFN	0°C to 70°C
LTC4370IDE#PBF	LTC4370IDE#TRPBF	4370	16-Lead (4mm × 3mm) Plastic DFN	-40°C to 85°C
LTC4370CMS#PBF	LTC4370CMS#TRPBF	4370	16-Lead Plastic MSOP	0°C to 70°C
LTC4370IMS#PBF	LTC4370IMS#TRPBF	4370	16-Lead Plastic MSOP	-40°C to 85°C

Consult LTC Marketing for parts specified with wider operating temperature ranges. *The temperature grade is identified by a label on the shipping container.

For more information on lead free part marking, go to: <http://www.linear.com/leadfree/>

For more information on tape and reel specifications, go to: <http://www.linear.com/tapeandreel/>

ELECTRICAL CHARACTERISTICS

The ● denotes those specifications which apply over the full operating temperature range, otherwise specifications are at $T_A = 25^\circ\text{C}$. $V_{IN1} = V_{IN2} = 12\text{V}$, $\text{OUT} = V_{IN}$, V_{CC} open, unless otherwise noted.

SYMBOL	PARAMETER	CONDITIONS	MIN	TYP	MAX	UNITS	
Supplies							
V_{IN}	V_{IN1} , V_{IN2} Operating Range	With External V_{CC} Supply	● 2.9 ● 0		18 V_{CC}	V V	
$V_{CC(EXT)}$	V_{CC} External Supply Operating Range	V_{IN1} , $V_{IN2} \leq V_{CC}$	● 2.9		6	V	
$V_{CC(REG)}$	V_{CC} Regulated Voltage		● 4.5	5	5.5	V	
I_{IN}	V_{IN1} , V_{IN2} Current Enabled, Higher Supply Enabled, Lower Supply Pull-Up Disabled	Other $V_{IN} = 11.7\text{V}$, Both $\overline{EN} = 0\text{V}$ Other $V_{IN} = 12.3\text{V}$, Both $\overline{EN} = 0\text{V}$ Both $V_{IN} = 0\text{V}$, $V_{CC} = 5\text{V}$, Both $\overline{EN} = 0\text{V}$ Both $\overline{EN} = 1\text{V}$	● ● ● ●	2.1 320 -110 80	3 450 -180 180	mA μA μA μA	
I_{CC}	V_{CC} Current Enabled Disabled	$V_{CC} = 5\text{V}$, Both $V_{IN} = 1.2\text{V}$, Both $\overline{EN} = 0\text{V}$ $V_{CC} = 5\text{V}$, Both $V_{IN} = 1.2\text{V}$, Both $\overline{EN} = 1\text{V}$	● ●	2 105	2.8 220	mA μA	
$V_{CC(UVLO)}$	V_{CC} Undervoltage Lockout Threshold	V_{CC} Rising	● 2.3	2.55	2.7	V	
$\Delta V_{CC(HYST)}$	V_{CC} Undervoltage Lockout Hysteresis		● 40	120	300	mV	
Load Share							
$V_{EA(OS)}$	Error Amplifier Input Offset		●	0	± 2	mV	
$g_{m(EA)}$	Error Amplifier Gain ($-\Delta I_{COMP}/\Delta V_{OUT}$)			150		μS	
$V_{FR(MIN)}$	Minimum Forward Regulation Voltage ($V_{IN} - \text{OUT}$)	$V_{IN} = 1.2\text{V}$, $V_{CC} = 5\text{V}$ $V_{IN} = 12\text{V}$	● 2 ● 2	12 25	25 50	mV mV	
$V_{FR(MAX)}$	Maximum Forward Regulation Voltage ($V_{IN} - \text{OUT}$)	$R_{RANGE} = 4.99\text{k}$, $V_{IN} = 1.2\text{V}$, $V_{CC} = 5\text{V}$ $R_{RANGE} = 4.99\text{k}$, $V_{IN} = 12\text{V}$ $R_{RANGE} = 49.9\text{k}$, $V_{IN} = 1.2\text{V}$, $V_{CC} = 5\text{V}$ $R_{RANGE} = 49.9\text{k}$, $V_{IN} = 12\text{V}$	● ● ● ●	40 45 425 440	62 75 511 524	82 100 575 590	mV mV mV mV
I_{RANGE}	RANGE Pull-Up Current	RANGE = 0.2V	●	-8.8	-10	-11.2	μA
$V_{RANGE(TH)}$	RANGE Load Share Disable Threshold		●	$V_{CC} - 0.5$	$V_{CC} - 0.3$	$V_{CC} - 0.1$	V
Gate Drive							
ΔV_{GATE}	MOSFET Gate Drive ($\text{GATE} - V_{IN}$)	$V_{FWD} = 0.2\text{V}$; $I = 0$, $-1\mu\text{A}$; Highest $V_{IN} = 12\text{V}$ $V_{FWD} = 0.2\text{V}$; $I = 0$, $-1\mu\text{A}$; Highest $V_{IN} = 2.9\text{V}$	● ●	10 4.5	12 7	14 9	V V
$t_{ON(GATE)}$	GATE1, GATE2 Turn-On Propagation Delay	$V_{FWD} (= V_{IN} - \text{OUT})$ Step: $-0.3\text{V} \uparrow 0.3\text{V}$	●	0.4	1	μs	
$t_{OFF(GATE)}$	GATE1, GATE2 Turn-Off Propagation Delay	V_{FWD} Step: $0.3\text{V} \downarrow -0.3\text{V}$	●	0.4	1	μs	
$I_{GATE(PK)}$	GATE1, GATE2 Peak Pull-Up Current GATE1, GATE2 Peak Pull-Down Current	$V_{FWD} = 0.4\text{V}$, $\Delta V_{GATE} = 0\text{V}$, $\text{CPO} = 17\text{V}$ $V_{FWD} = -2\text{V}$, $\Delta V_{GATE} = 5\text{V}$	● ●	-0.9 0.9	-1.4 1.4	-1.9 1.9	A A
$I_{GATE(OFF)}$	GATE1, GATE2 Off Pull-Down Current	Corresponding $\overline{EN} = 1\text{V}$, $\Delta V_{GATE} = 2.5\text{V}$	●	65	110	160	μA
Input/Output Pins							
$V_{EN(TH)}$	$\overline{EN1}$, $\overline{EN2}$ Threshold Voltage	\overline{EN} Falling	●	580	600	620	mV
$\Delta V_{EN(TH)}$	$\overline{EN1}$, $\overline{EN2}$ Threshold Hysteresis		●	2	8	20	mV
I_{EN}	$\overline{EN1}$, $\overline{EN2}$ Current	At 0.6V	●		0	± 1	μA
I_{OUT}	OUT1, OUT2 Current Enabled Disabled	$\text{OUT}_n = 0\text{V}$, 12V ; Both $\overline{EN} = 0\text{V}$ Both $\overline{EN} = 1\text{V}$	● ●	-70	16	260 40	μA μA
$I_{CPO(UP)}$	CPO1, CPO2 Pull-Up Current	$\text{CPO} = V_{IN}$	●	-40	-70	-115	μA
V_{OL}	FETON1, FETON2 Output Low Voltage	$I = 1\text{mA}$ $I = 3\text{mA}$	● ●		0.12 0.36	0.4 1.2	V V
V_{OH}	FETON1, FETON2 Output High Voltage	$I = -1\mu\text{A}$, $V_{FWD} = 1\text{V}$	●	$V_{CC} - 1.4$	$V_{CC} - 0.9$	$V_{CC} - 0.5$	V

ELECTRICAL CHARACTERISTICS

SYMBOL	PARAMETER	CONDITIONS	MIN	TYP	MAX	UNITS	
I_{FETON}	FETON1, FETON2 Leakage Current	At 12V	●	0	±1	μA	
$\Delta V_{GATE(ON)}$	MOSFET On Detect Threshold (GATE - V_{IN})	FETON Transitions High	●	0.28	0.7	1.1	V

Note 1: Stresses beyond those listed under Absolute Maximum Ratings may cause permanent damage to the device. Exposure to any Absolute Maximum Rating condition for extended periods may affect device reliability and lifetime.

Note 2: All currents into device pins are positive; all currents out of device pins are negative. All voltages are referenced to GND unless otherwise specified.

Note 3: Internal clamps limit the GATE and CPO pins to a minimum of 10V above, and a diode below the corresponding V_{IN} pin. Driving these pins to voltages beyond the clamp may damage the device.

TYPICAL PERFORMANCE CHARACTERISTICS $T_A = 25^\circ\text{C}$, $V_{IN1} = V_{IN2} = 12\text{V}$, $OUT = V_{IN}$, V_{CC} open, unless otherwise noted.

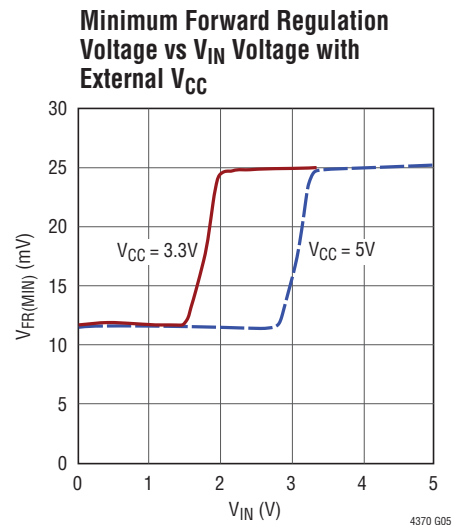
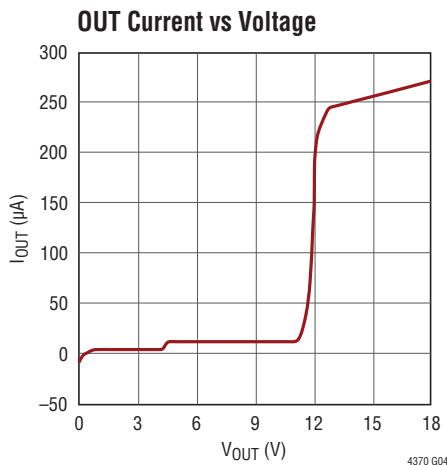
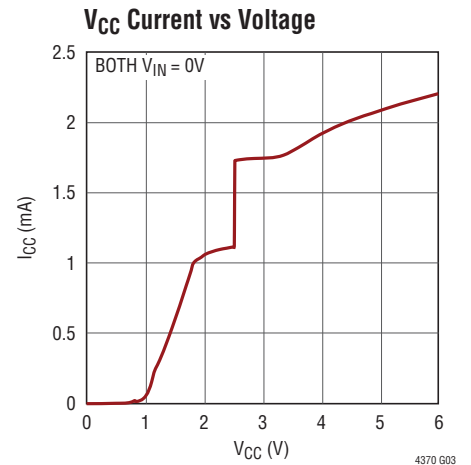
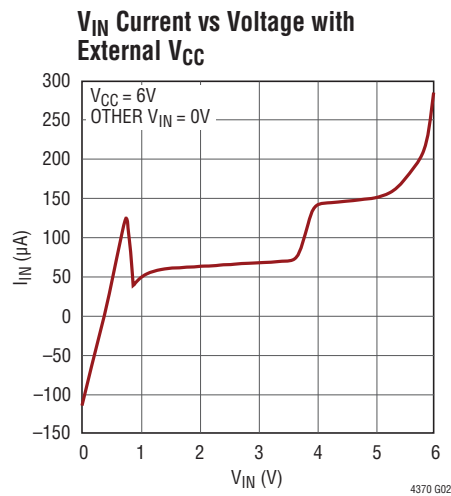
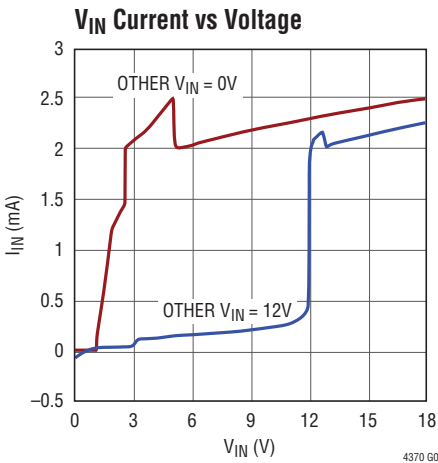

TYPICAL PERFORMANCE CHARACTERISTICS $T_A = 25^\circ\text{C}$, $V_{IN1} = V_{IN2} = 12\text{V}$, $\text{OUT} = V_{IN}$, V_{CC} open, unless otherwise noted.

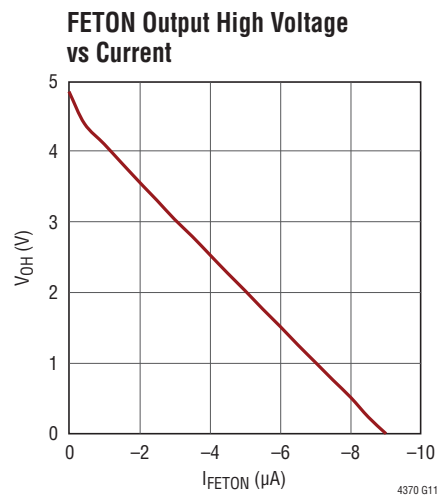
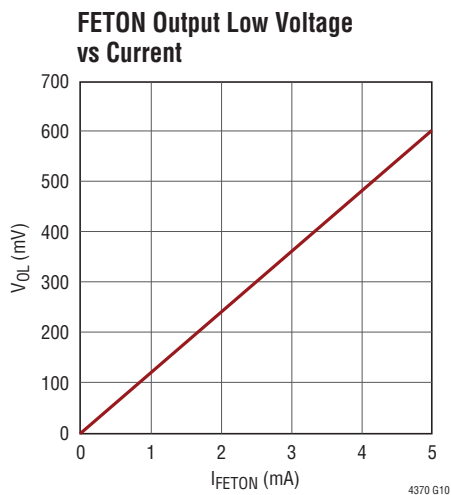
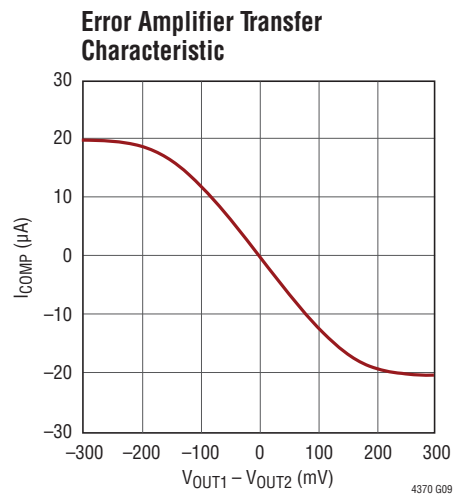
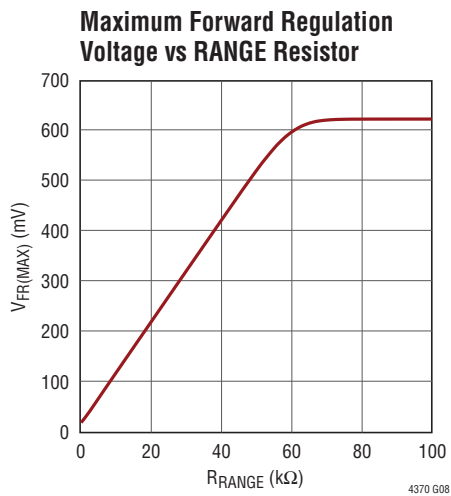
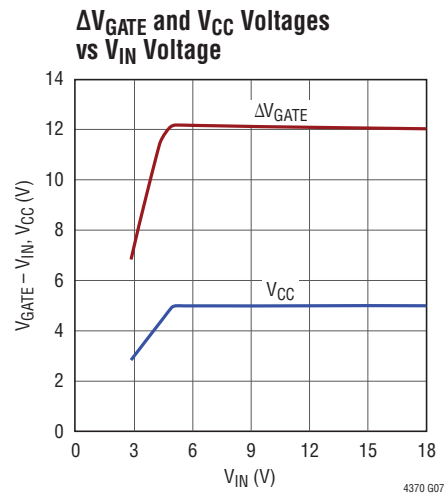
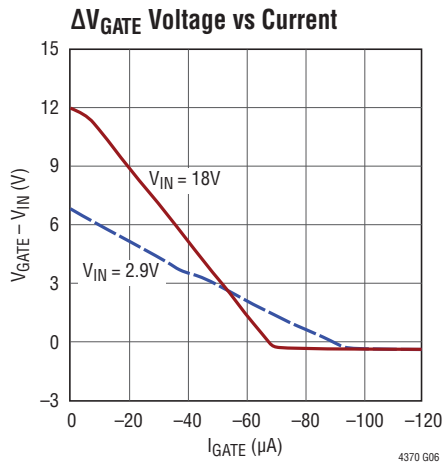

PIN FUNCTIONS

COMP: Error Amplifier Compensation. Connect a capacitor from this pin to GND. The value of this capacitor should be approximately 10 to 50 times the gate capacitance (C_{ISS}) of the MOSFET switch. Maintain low board leakage on this pin for best load sharing accuracy. For example, 100nA of leakage current (equal to 1V across 10M Ω) increases the error amplifier offset by 0.7mV. Leave this pin open if only using ideal diode mode.

CP01, CP02: Charge Pump Output. Connect a capacitor from this pin to the corresponding V_{IN} pin. The value of this capacitor should be approximately 10 \times the gate capacitance (C_{ISS}) of the MOSFET switch. The charge stored on this capacitor is used to pull up the gate during a fast turn-on. Leave this pin open if fast turn-on is not needed.

EN1, EN2: Enable Input. Keep this pin below 0.6V to enable sharing and diode control on the corresponding supply. Driving this pin high shuts off the MOSFET gate (current can still flow through its body diode). The comparator has a built-in hysteresis of 8mV. Having both \overline{EN} pins high lowers the current consumption of the device.

Exposed Pad (DE Package Only): The exposed pad may be left open or connected to device ground.

FETON1, FETON2: MOSFET Status Output. This pin is pulled low by an internal switch when GATE is less than 0.7V above V_{IN} to indicate an off MOSFET. Because of this, it may also signal off if small currents are flowing through a high- g_m MOSFET with a large forward voltage across it. An internal 500k resistor pulls this pin up to a diode below V_{CC} . It may be pulled above V_{CC} using an external pull-up. Tie to GND or leave open if unused.

GATE1, GATE2: MOSFET Gate Drive Output. Connect this pin to the gate of the external N-channel MOSFET switch. An internal clamp limits the gate voltage to 12V above, and a diode below the input supply. During fast turn-on, a 1.4A pull-up current charges GATE to CPO. During fast turn-off, a 1.4A pull-down current discharges GATE to V_{IN} .

GND: Device Ground.

OUT1, OUT2: Output Voltage and Current Sense Input. Connect this pin to the input side of the supply's current sense resistor. A Kelvin connection is important for accurate current sharing. The voltage sensed at this pin is used to control the MOSFET gate.

RANGE: Supply Differential Voltage Load Sharing Range. Connect a resistor (below 60k) from this pin to GND. A 10 μ A internal pull-up current source into this resistor sets the pin voltage V_{RANGE} . The two supplies will typically share the load current if their voltage difference is within $\pm V_{RANGE}$. The maximum sharing range is $\pm 0.6V$, obtained by leaving RANGE open. Connecting this pin to V_{CC} disables load share control and the device behaves as a dual ideal diode controller.

V_{CC}: Low Voltage Supply. Connect a 0.1 μ F capacitor from this pin to ground. For $V_{IN} \geq 2.9V$ this pin provides decoupling for an internal regulator that generates a 5V supply. For applications where both $V_{IN} < 2.9V$, also connect an external supply in the 2.9V to 6V range to this pin.

V_{IN1}, V_{IN2}: Voltage Sense and Supply Input. Connect this pin to the supply side of the MOSFET. The low voltage supply V_{CC} is generated from the higher of V_{IN1} and V_{IN2} . The voltage sensed at this pin is used to control the MOSFET gate.

FUNCTIONAL DIAGRAM

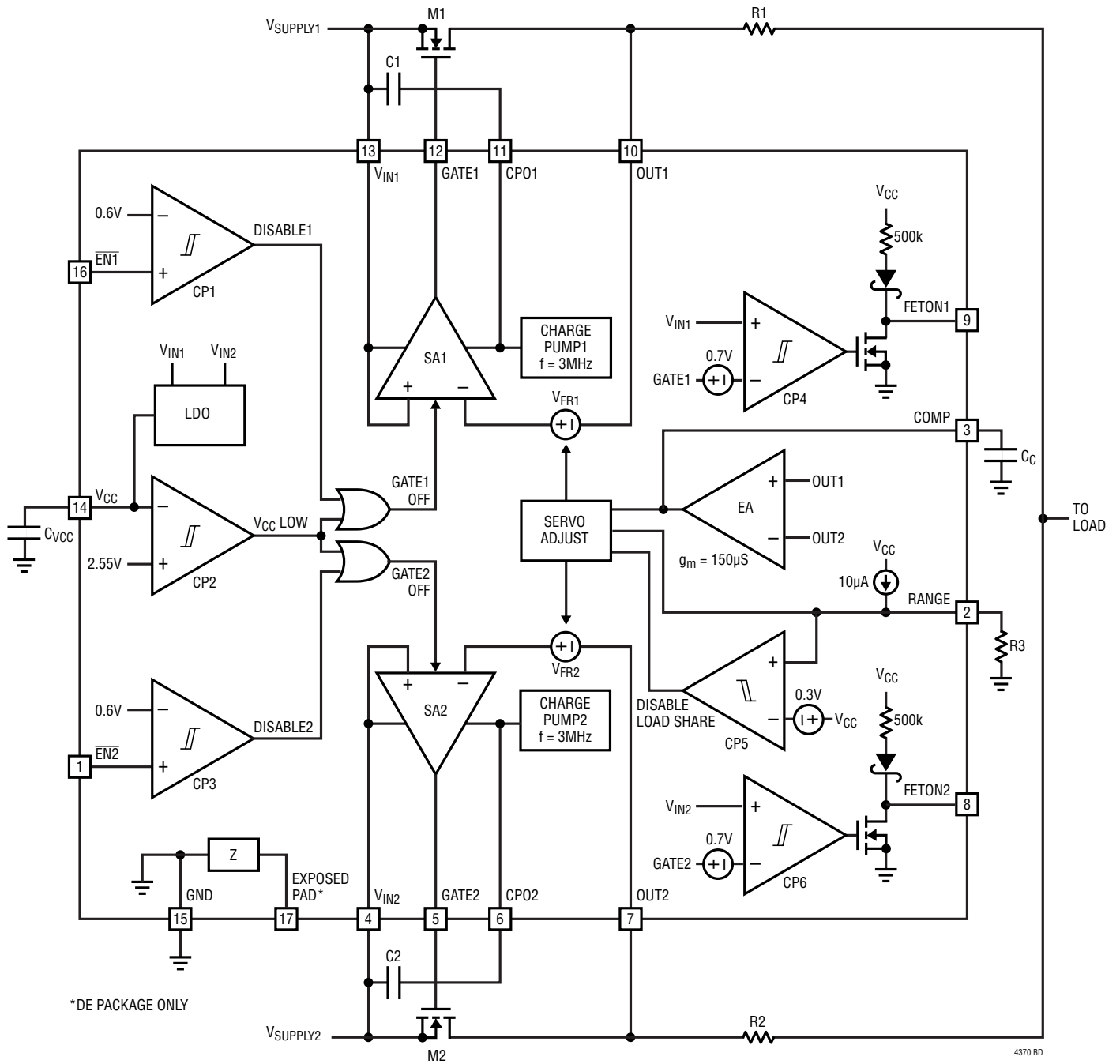

OPERATION

The LTC4370 controls N-channel MOSFETs, M1 and M2, to share the load between two supplies. Error amplifier EA compares OUT1 to OUT2 and sets the servo command voltages, V_{FR1} and V_{FR2} , for servo amplifiers, SA1 and SA2. When enabled, each servo amplifier controls the gate of the external MOSFET to regulate its forward voltage drop ($V_{FWD} = V_{IN} - OUT$) to V_{FR} . The combined action of EA and SA forces OUT1 to equal OUT2. Having the power path resistance from OUT1 to the load (R1) equal that from OUT2 to the load (R2) forces each supply to source half of the load current.

The lower limit of V_{FR} adjustment is 25mV at higher supply voltages (reducing to 12mV at lower voltages to conserve power and voltage drop). The upper limit is $V_{RANGE} + 25mV$ (or $V_{RANGE} + 12mV$). V_{RANGE} itself is set by the 10 μ A pull-up current source into resistor R3. The servo adjust block ensures that only the higher supply's V_{FR} is adjusted up while the other is pinned to the minimum. Tying RANGE to V_{CC} (CP5) forces both V_{FR} to the minimum, transforming the device into a dual ideal diode controller.

The servo amplifier raises the gate voltage to enhance the MOSFET whenever the load current causes the drop to exceed V_{FR} . For large output currents the MOSFET gate is driven fully on and the voltage drop is equal to $I_{FET} \cdot R_{DS(ON)}$.

In the case of an input supply short-circuit, when the MOSFET is conducting, a large reverse current starts flowing from the load towards the input. SA detects this failure condition as soon as it appears and turns off the MOSFET by rapidly pulling down its gate.

SA quickly pulls up the gate whenever it senses a large forward voltage drop. An external capacitor (C1, C2) between the CPO and V_{IN} pins is needed for fast gate pull-up. This capacitor is charged up, at device power-up, by the internal charge-pump. The stored charge is used for the fast gate pull-up.

The GATE pin sources current from the CPO pin and sinks current to the V_{IN} and GND pins. Clamps limit the GATE and CPO voltages to 12V above and a diode below V_{IN} . Internal switches pull the FETON pins low when the GATE to V_{IN} voltage is below 0.7V to indicate that the external MOSFET is off (body diode could still conduct).

LDO is a low dropout regulator that generates a 5V supply at the V_{CC} pin from the highest V_{IN} input. When supplies below 2.9V are being shared, an external supply in the 2.9V to 6V range is required at the V_{CC} pin.

V_{CC} and \overline{EN} pin comparators, CP1 to CP3, control power passage. The MOSFET is held off whenever the \overline{EN} pin is above 0.6V, or the V_{CC} pin is below 2.55V. A high on both \overline{EN} pins lowers the current consumption of the device.

APPLICATIONS INFORMATION

High availability systems often employ parallel-connected power supplies or battery feeds to achieve redundancy and enhance system reliability. ORing diodes have been a popular means of connecting these supplies at the point of load. System uptime improves further if these paralleled supplies also share the load current.

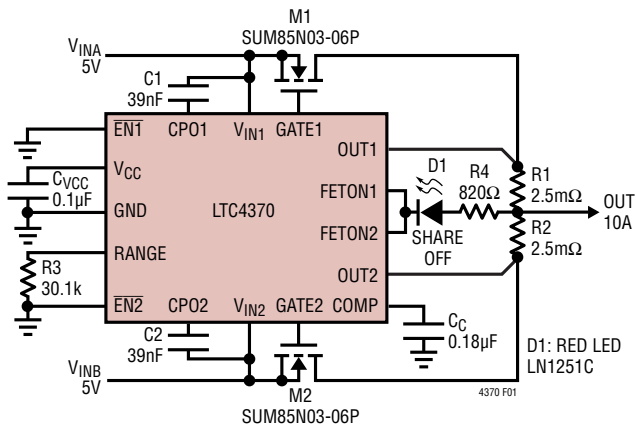

Figure 1. 5V Diode-OR Load Share with Status Light

Current Sharing Characteristic

The LTC4370 load shares the two supplies by dropping their voltage difference across the MOSFETs in series with them (see Figure 1). The MOSFET on the lower supply drops the minimum servo voltage $V_{FR(MIN)}$ (12mV or 25mV depending on supply voltage levels), while the other MOSFET drops $V_{FR(MIN)}$ plus the supply voltage difference. This equalizes both the OUT pin voltages, and by Ohm's law the current that flows through the sense resistors. Figure 2a illustrates this. It shows the higher supply's MOSFET forward voltage drop, V_{FWD} , increasing to compensate the supply difference up to $\pm 500mV$.

The upper limit of the servo command adjustment is the minimum servo plus the RANGE pin voltage (500mV in Figure 2). Hence, when the two supplies differ by a voltage equal to V_{RANGE} , the higher supply's V_{FWD} is pinned at the maximum servo voltage $V_{FR(MAX)}$. If the supplies diverge by more than V_{RANGE} , the OUT pin voltages start

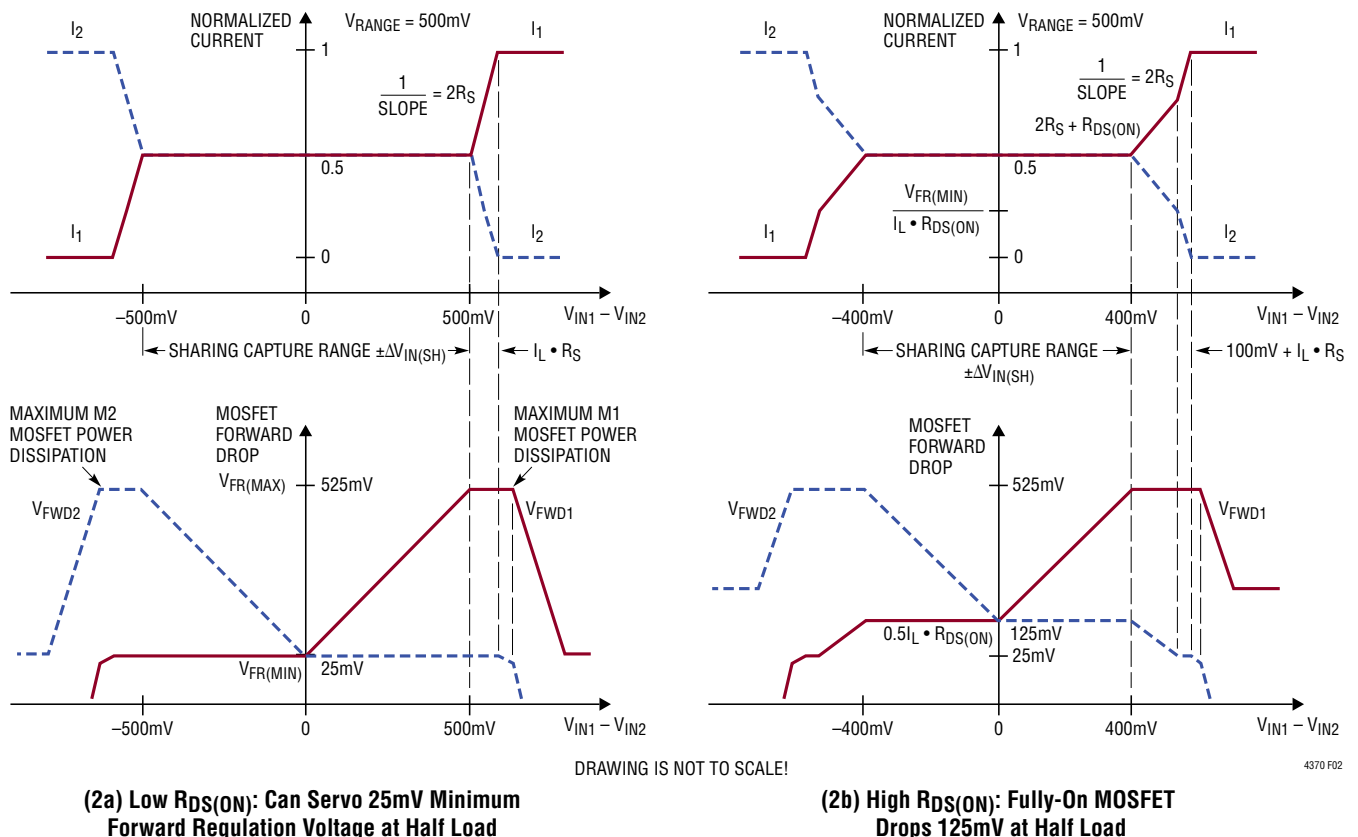

Figure 2. Load Sharing Characteristics

APPLICATIONS INFORMATION

diverging, and so too, the supply currents. As the supply voltages separate, the entire load current is steered to the higher supply. Now, the servo command across the higher supply's MOSFET is folded back from the maximum to the minimum servo to minimize power dissipated in the MOSFET. The sharing capture range, $\Delta V_{IN(SH)}$, in Figure 2a is $\pm 500\text{mV}$, set by V_{RANGE} . Figure 2b will be discussed later in the MOSFET Selection section.

RANGE Pin Configuration

The RANGE pin resistor is decided by the design trade-off between the sharing capture range and the power dissipated in the MOSFET. A larger R_{RANGE} increases the capture range at the expense of enhanced power dissipation and reduced load voltage. On the other hand, supplies with tight tolerances can afford a smaller capture range and therefore cooler operation of the MOSFETs.

As mentioned, the upper limit of the servo command adjustment is V_{RANGE} plus the minimum forward regulation voltage. Since an internal $10\mu\text{A}$ pull-up current flowing through the external resistor sets V_{RANGE} :

$$V_{FR(MAX)} = 10\mu\text{A} \cdot R_{RANGE} + V_{FR(MIN)} \quad (1)$$

If R_{RANGE} is larger than 60k (including the pin open state), the internal limit for the first term on the right-hand side of Equation 1 is 600mV , setting $V_{FR(MAX)}$ to 612mV or 625mV . Note that servo voltages nearing the MOSFET's body diode voltage may divert some or all current to the diode especially at hot temperatures. This may either cause FETON to go low if V_{GS} falls below 0.7V , or

loss of sharing control. Also note that an open RANGE pin biases itself to a voltage greater than 600mV .

Connecting the RANGE pin to V_{CC} disables the load sharing loop. The servo voltages for both MOSFETs are fixed at the minimum with no adjustment. The device now behaves as a dual ideal diode controller. This is handy for testing purposes. Use the LTC4353 if only a dual ideal diode controller is needed.

Power Supply Configuration

The LTC4370 can load share high side supplies down to 0V rail voltage. This requires powering the V_{CC} pin with an early external supply in the 2.9V to 6V range. In this range of operation V_{IN} should be lower than V_{CC} . If V_{CC} powers up after V_{IN} , and backfeeding of V_{CC} by the internal 5V LDO is a concern, then a series resistor (few 100Ω) or Schottky diode limits device power dissipation and backfeeding of a low V_{CC} supply when any V_{IN} is high. A $0.1\mu\text{F}$ bypass capacitor should also be connected between the V_{CC} and GND pins, close to the device. Figure 3 illustrates this.

If either V_{IN} operates above 2.9V , then the external supply at V_{CC} is not needed. The $0.1\mu\text{F}$ capacitor is still required for bypassing.

Start of Sharing

When currents are not being shared either because the load current or one of the supplies is off, the COMP voltage is railed towards 0V or 2V depending on the input signal to the error amplifier and its offset. For example,

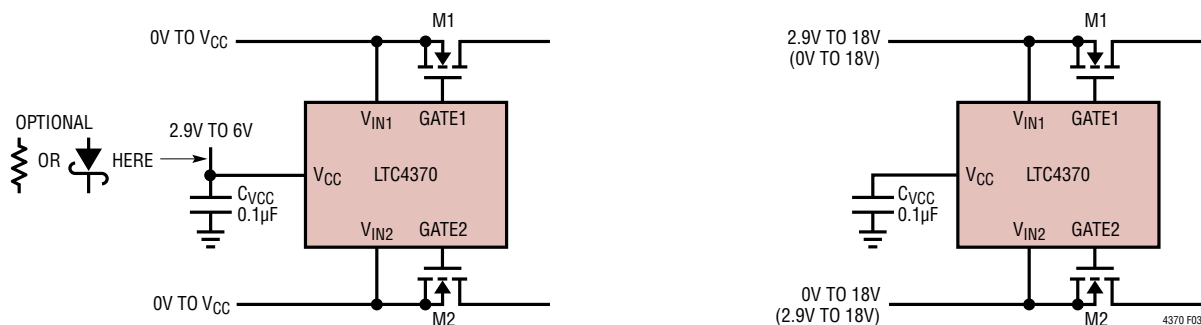

Figure 3. Power Supply Configurations

APPLICATIONS INFORMATION

in the absence of load current the differential input voltage to the error amplifier is zero and the COMP current is $g_{m(EA)} \cdot V_{EA(OS)}$. Before sharing can start, the COMP voltage has to slew towards its operating point of 0.7V (when $V_{IN1} < V_{IN2}$) or 1.24V ($V_{IN1} > V_{IN2}$). This delay is determined by the differential input signal to the error amplifier (which is $\Delta V_{OUT} = OUT1 - OUT2 = (I_1 - I_2) \cdot R_S$), its g_m and the COMP capacitor value. Depending on how the currents split before converging, the delay can vary from 1 to 5 times:

$$\frac{C_C \cdot \Delta V_{COMP}}{g_{m(EA)} \cdot I_L \cdot R_S}$$

Figure 4a shows the case where a 5.1V V_{IN1} is turned on while V_{IN2} is at 4.9V supplying 10A. Initially, COMP is railed low to 0.1V since ΔV_{OUT} ($-I_2 \cdot R_S$) is negative, and needs to rise to 1.24V as the final V_{IN1} is higher than V_{IN2} . With V_{IN1} off, ΔV_{IN} is large and negative, causing the forward regulation voltage of the second supply V_{FR2} to be folded back to the minimum $V_{FR(MIN)}$ (travelling from left to right in Figure 2a). As the ΔV_{IN} magnitude decreases, V_{FR2} rises to the maximum $V_{FR(MAX)}$, lowering I_2 and the load voltage. COMP is around 0.7V when V_{FR2} is being adjusted. When COMP reaches 1.24V, V_{FR2} is kept at the minimum and V_{FR1} is adjusted appropriately to compensate for the 0.2V of ΔV_{IN} . The sharing closure is smoother for the case where $V_{IN1} < V_{IN2}$ since COMP only has to slew to 0.7V to lower V_{FR2} (Figure 4b).

MOSFET Selection

The LTC4370 drives N-channel MOSFETs to conduct the load current. The important parameters of the MOSFET are its maximum drain-source voltage BV_{DSS} , maximum gate-source voltage $V_{GS(MAX)}$, on-resistance $R_{DS(ON)}$, and maximum power dissipation $P_{D(MAX)}$.

If an input is connected to ground, the full supply voltage can appear across the MOSFET. To survive this, the BV_{DSS} must be higher than the supply voltages. The $V_{GS(MAX)}$ rating of the MOSFET should exceed 14V since that is the upper limit of the internal GATE to V_{IN} clamp.

To obtain the maximum sharing capture range, the $R_{DS(ON)}$ should be low enough for the servo amplifier to regulate the minimum forward regulation voltage across the MOSFET while it's conducting half of the load current. If it cannot, the gate voltage will be railed high. Hence, the $R_{DS(ON)}$ value in the MOSFET data sheet should be looked up for 10V or 4.5V gate drive depending on the V_{IN} voltage. Since the OUT voltages are equal, the breakpoint for exact sharing in the higher $R_{DS(ON)}$ case is:

$$\Delta V_{IN(SH)} = V_{FR(MAX)} - 0.5 I_L \cdot R_{DS(ON)} \quad (2)$$

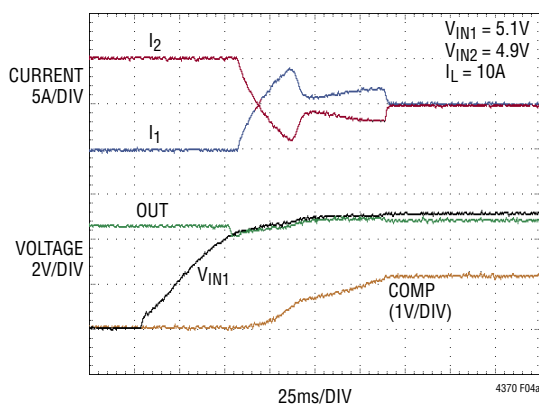

(4a) $V_{IN1} > V_{IN2}$

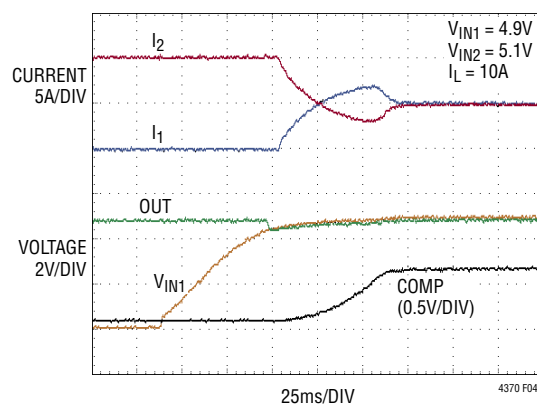

(4b) $V_{IN1} < V_{IN2}$

Figure 4. Start of Sharing at V_{IN1} Turn-On

APPLICATIONS INFORMATION

In Figure 2b, $0.5I_L \cdot R_{DS(ON)}$ is 125mV. The higher $R_{DS(ON)}$ rails the servo amplifier high as it cannot regulate the 25mV $V_{FR(MIN)}$ across the lower supply's MOSFET. Compared to Figure 2a, the sharing capture range shrinks by 100mV (125mV – 25mV) to ± 400 mV. However, the ΔV_{IN} over which currents are shared partially stays the same at $500\text{mV} + I_L \cdot R_S$. Even when not maximizing sharing range, $I_L \cdot R_{DS(ON)}$ should be kept below 75mV for optimum performance.

The peak power dissipation in the MOSFET occurs when the entire load current is being sourced by one supply with the maximum forward regulation voltage dropped across the MOSFET (as shown in Figure 2a). Therefore, the $P_{D(MAX)}$ rating of the MOSFET should satisfy:

$$P_{D(MAX)} \geq I_L \cdot V_{FR(MAX)} \quad (3)$$

Table 1 provides starting guidelines for the type of MOSFET package and heat sink required at various levels of power dissipation. These are typical ranges for a room temperature ambient with no air flow.

Table 1. Guidelines for MOSFET Power Dissipation

MAXIMUM POWER DISSIPATED	MOSFET PACKAGE	HEAT SINK
0.5W to 1W	SO-8	PCB
1W to 2W	SO-8 With Exposed Pad, D-Pak (TO-252)	PCB
	TO-220	Standing in Free Air
2W to 4W	DD-Pak (TO-263), TO-220	PCB
4W to 10W	TO-220	Stamping
10W to 20W	TO-220	Casting, Extrusion
20W to 50W	TO-247, TO-3P	Extrusion

Sense Resistor Selection

The sense resistor voltage drop dictates the current sharing accuracy. Sharing error, due to the error amplifier input offset, decreases with increasing sense voltage as:

$$\frac{\Delta I}{I_L} = \frac{|I_1 - I_2|}{I_L} = \frac{|V_{EA(OS)}|}{I_L \cdot R_S} = \frac{2\text{mV}}{I_L \cdot R_S} \quad (4)$$

I_1 and I_2 are the two supply currents, I_L is the load current ($I_1 + I_2 = I_L$), R_S is the sense resistor value, and $V_{EA(OS)}$ is the input offset of the internal error amplifier. A 25mV sense resistor voltage drop with half of the load current flowing through it (i.e., $I_L \cdot R_S = 50\text{mV}$) gives a 4% sharing error. A larger sense resistance may also be needed if there is a connector in between the OUT pins and the load to minimize the effect of its resistance. At larger sense voltages the accuracy will be limited by the sense resistor tolerance.

If sharing accuracy requirements can be relaxed, power dissipated in the sense resistor can be reduced by selecting a lower resistance. Worst-case power dissipation happens at full load, i.e., when load current is not being shared. While reducing the sense resistance, note that the sharing loop does not close for load currents below $V_{EA(OS)}/R_S$.

The two sense resistors can have different values if the application does not require the load current to be shared equally between the supplies. In such a case:

$$\frac{R_{S1}}{R_{S2}} = \frac{I_2}{I_1} \quad (5)$$

CPO Capacitor Selection

The recommended value of the capacitor between the CPO and V_{IN} pins is approximately $10\times$ the input capacitance C_{ISS} of the MOSFET. A larger capacitor takes a correspondingly longer time to be charged by the internal charge pump. A smaller capacitor suffers more voltage drop during a fast gate turn-on event as it shares charge with the MOSFET gate capacitance.

APPLICATIONS INFORMATION

External CPO Supply

The internal charge pump takes milliseconds to charge up the CPO capacitor especially during device power-up. This time can be shortened by connecting an external supply to the CPO pin. A series resistor is needed to limit the current into the internal clamp between the CPO and V_{IN} pins. The CPO supply should also be higher than the main input supply to meet the gate drive requirements of the MOSFET. Figure 5 shows such a 3.3V load share application, where a 12V supply is connected to the CPO pins through a 1k resistor. The 1k limits the current into the CPO pin when the V_{IN} pin is grounded. For the 8.7V of gate drive ($12V - 3.3V$), logic-level MOSFETs would be an appropriate choice for M1 and M2.

Loop Stability

The servo amplifier loop is compensated by the gate capacitance of the N-channel power MOSFET. No further compensation components are normally required. In the case when a MOSFET with less than 1nF gate capacitance is chosen, a 1nF compensation capacitor connected across the gate and source might be required.

The load sharing control loop is compensated by the capacitor from the COMP pin to ground. This capacitor should be at least $50\times$ the input capacitance C_{ISS} of the MOSFET. A larger capacitor improves stability at the ex-

pense of increased sharing closure delay, while a smaller capacitor can cause the two supply currents to switch back and forth before settling. The COMP capacitor can be just $10\times C_{ISS}$ when a CPO capacitor is omitted, i.e., when fast gate turn-on is not used (see Figure 6).

Input and Output Capacitance for Pulsed Loads

For pulsed loads, the load current will be shared every cycle at frequencies below 100Hz. At higher frequencies, each cycle's current may not be shared but the time average of the currents will be. Bypassing capacitance on the inputs should be provided to minimize glitches and ripple. This is important since the controller tries to compensate for the supply voltage differences to achieve load sharing. Sufficient load capacitance should also be provided to enhance the DC component of the load current presented to the load share circuit. It is also important to design $I_L \cdot R_{DS(ON)}$ below 75mV, as mentioned earlier.

With very low duty cycle or very low frequency loads, the COMP voltage will rail whenever the load current falls below the sharing threshold of $V_{EA(OS)}/R_S$ for hundreds of milliseconds. At the start of the next load cycle there will be a sharing closure delay as COMP slews to its operating point around 0.7V or 1.24V. To avoid this delay, maintain the load current above $V_{EA(OS)}/R_S$.

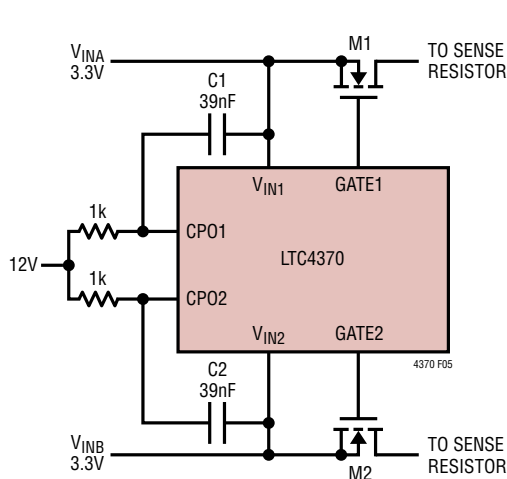

Figure 5. 3.3V Load Share with External 12V Supply Powering CPO for Faster Start-Up and Refresh

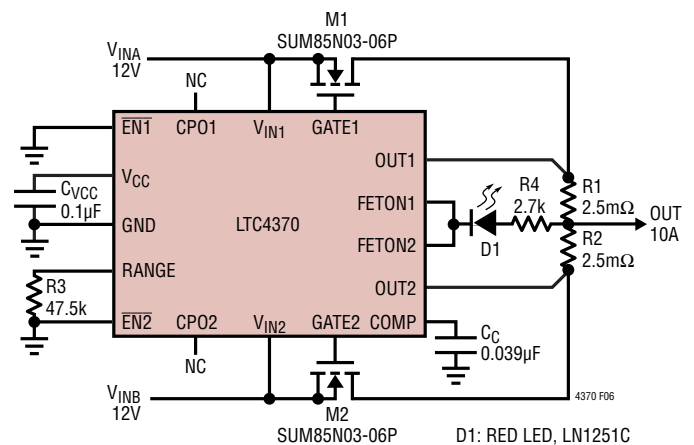

Figure 6. Current Sharing 12V Supplies

APPLICATIONS INFORMATION

Input Transient Protection

When the capacitances at the input and output are very small, rapid changes in current can cause transients that exceed the 24V absolute maximum rating of the V_{IN} and OUT pins. In ORing applications, one surge suppressor connected from OUT to ground clamps all the inputs. In the absence of a surge suppressor, an output capacitance of $10\mu\text{F}$ is sufficient in most applications to prevent the transient from exceeding 24V.

12V Design Example

This design example demonstrates the selection of components in a 12V system with a 10A maximum load current and $\pm 2\%$ tolerance supplies (Figure 6). That is followed by the recalculations involved for a similar 5V system (Figure 1).

First, calculate the $R_{DS(ON)}$ of the MOSFET to achieve the desired forward drop at full load. Assuming a V_{FWD} of 50mV:

$$R_{DS(ON)} \leq \frac{V_{FWD}}{I_{LOAD}} = \frac{50\text{mV}}{10\text{A}} = 5\text{m}\Omega$$

The SUM85N03-06P offers a good solution in a DD-Pak (TO-263) sized package with a $4.5\text{m}\Omega$ $R_{DS(ON)}$, 30V BV_{DSS} and 20V $V_{GS(MAX)}$. Since $0.5I_L \cdot R_{DS(ON)}$ is 22.5mV, the servo amplifier will be able to regulate the 25mV minimum forward regulation voltage leading to the maximum possible sharing range set by V_{RANGE} .

2% of 12V is 240mV. The sharing capture range, $\Delta V_{IN(SH)}$, needs to be about $2 \times 240\text{mV}$ ($\pm 480\text{mV}$) to work for most supply voltage differences. A 47.5k R_3 sets V_{RANGE} to 475mV. Equation 1 is used to calculate the maximum forward regulation voltage:

$$V_{FR(MAX)} = 10\mu\text{A} \cdot 47.5\text{k} + 25\text{mV} = 500\text{mV}$$

Equation 3 gives the maximum power dissipation in the MOSFET to be:

$$P_{D(MAX)} = 10\text{A} \cdot 500\text{mV} = 5\text{W}$$

Sufficient PCB area with air flow needs to be provided around the MOSFET drain to keep its junction temperature below the 175°C maximum.

A $2.5\text{m}\Omega$ sense resistor drops 25mV at full load and yields an error amplifier offset induced sharing error of $2\text{mV}/(10\text{A} \cdot 2.5\text{m}\Omega)$ or 8% (Equation 4). At full load, the sense resistor dissipates $10\text{A}^2 \cdot 2.5\text{m}\Omega$ or 250mW. Since a 12V supply is large enough to tolerate a diode drop, fast gate turn-on is not needed. Hence, the CPO capacitor is omitted. The input capacitance, C_{ISS} , of the MOSFET is about 3800pF. Since fast turn-on is not used, the COMP capacitor C_C can be just $10 \times C_{ISS}$ at $0.039\mu\text{F}$.

Red LED, D1, turns on when any one of the MOSFETs is off, indicating a break in sharing. It requires around 3mA for good luminous intensity. Accounting for a 2V diode drop and 0.6V V_{OL} , R_4 is set to 2.7k.

5V Design Example

For a 5V, 10A system with $\pm 3\%$ tolerance supplies and fast gate turn-on (Figure 1), the following components need to be recalculated: R_3 , C_1 , C_2 , C_C , and R_4 . R_3 is set to 30.1k to account for possible supply differences ($2 \cdot 3\% \cdot 5\text{V}$ yields $\pm 300\text{mV}$). C_1 and C_2 are set to $10 \times C_{ISS}$ at $0.039\mu\text{F}$. With fast turn-on, C_C is selected closer to $50 \times C_{ISS}$ at $0.18\mu\text{F}$. With the 5V supply, R_4 needs to be 820Ω to allow 3mA into the LED.

APPLICATIONS INFORMATION

PCB Layout Considerations

Kelvin connection of the OUT pins to the sense resistors is important for accurate current sharing. Place the MOSFET as close as possible to the sense resistor. Keep the traces to the MOSFET wide and short to minimize resistive losses. The PCB traces associated with the power path through the MOSFET should have low resistance. Thermal

management techniques such as sufficient drain copper area or heat sinks should be considered for optimal MOSFET power dissipation. See Figure 7.

It is also important to put C_{VCC} , the bypass capacitor, as close as possible between V_{CC} and GND. Place C1 and C2 near the CPO and V_{IN} pins. The COMP pin may need a guard ring to maintain low board leakage.

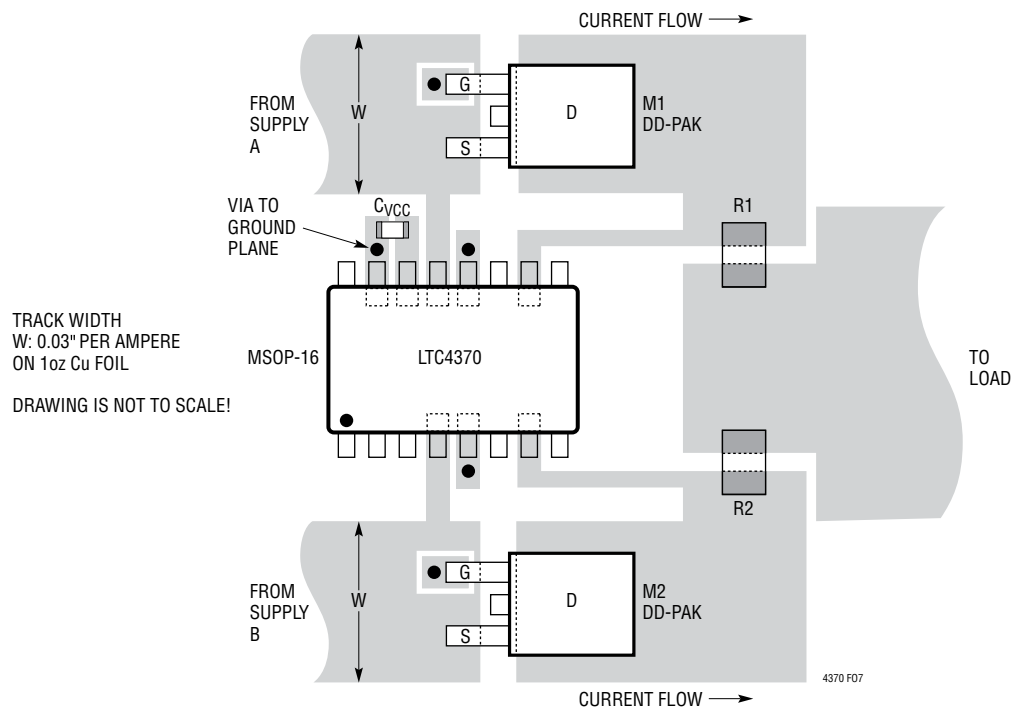
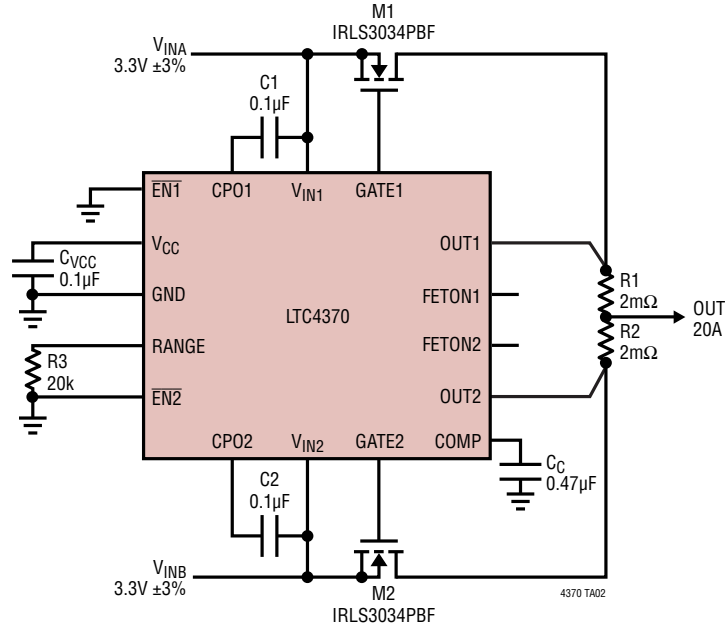

Figure 7. Recommended PCB Layout for M1, M2, C_{VCC} , R1, R2

TYPICAL APPLICATIONS

Current Sharing 3.3V Supplies for 20A Output



TYPICAL APPLICATIONS

12V Ideal Diode-OR by Tying RANGE to V_{CC} (to Compare Against Load Share).
Use LTC4353 if Load Share Is Not Desired

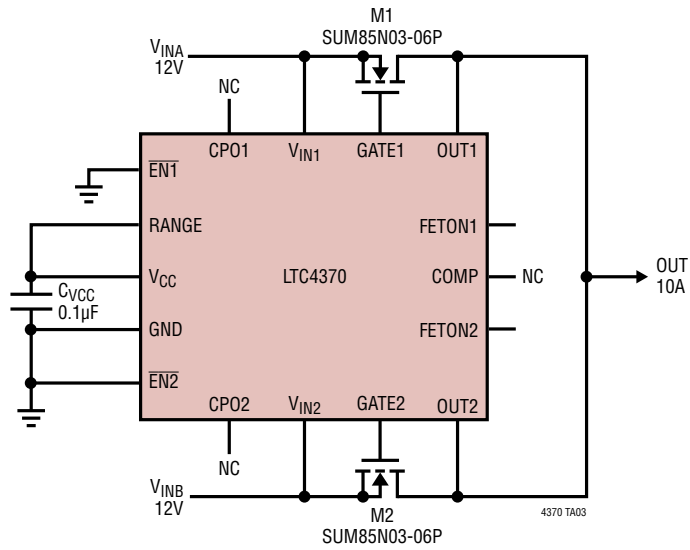

PACKAGE DESCRIPTION

Please refer to <http://www.linear.com/designtools/packaging/> for the most recent package drawings.

DE Package
16-Lead Plastic DFN (4mm × 3mm)
 (Reference LTC DWG # 05-08-1732 Rev 0)

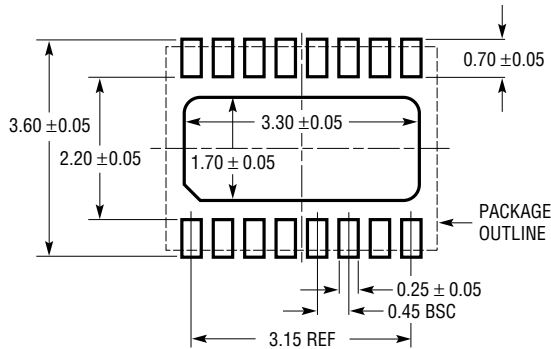

RECOMMENDED SOLDER PAD PITCH AND DIMENSIONS
 APPLY SOLDER MASK TO AREAS THAT ARE NOT SOLDERED

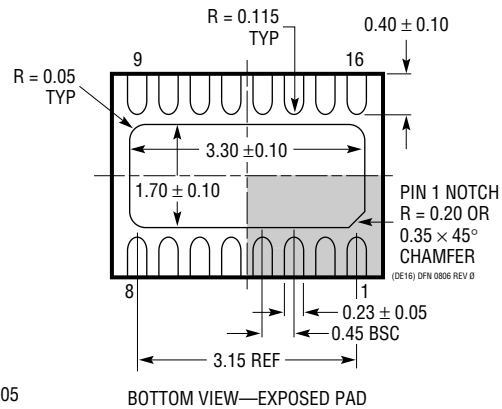
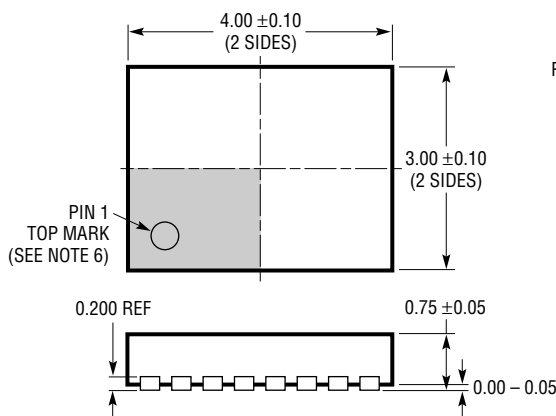

- NOTE:
1. DRAWING PROPOSED TO BE MADE VARIATION OF VERSION (WGED-3) IN JEDEC PACKAGE OUTLINE MO-229
 2. DRAWING NOT TO SCALE
 3. ALL DIMENSIONS ARE IN MILLIMETERS
 4. DIMENSIONS OF EXPOSED PAD ON BOTTOM OF PACKAGE DO NOT INCLUDE MOLD FLASH. MOLD FLASH, IF PRESENT, SHALL NOT EXCEED 0.15mm ON ANY SIDE
 5. EXPOSED PAD SHALL BE SOLDER PLATED
 6. SHADED AREA IS ONLY A REFERENCE FOR PIN 1 LOCATION ON THE TOP AND BOTTOM OF PACKAGE

PACKAGE DESCRIPTION

Please refer to <http://www.linear.com/designtools/packaging/> for the most recent package drawings.

MS Package 16-Lead Plastic MSOP

(Reference LTC DWG # 05-08-1669 Rev 0)

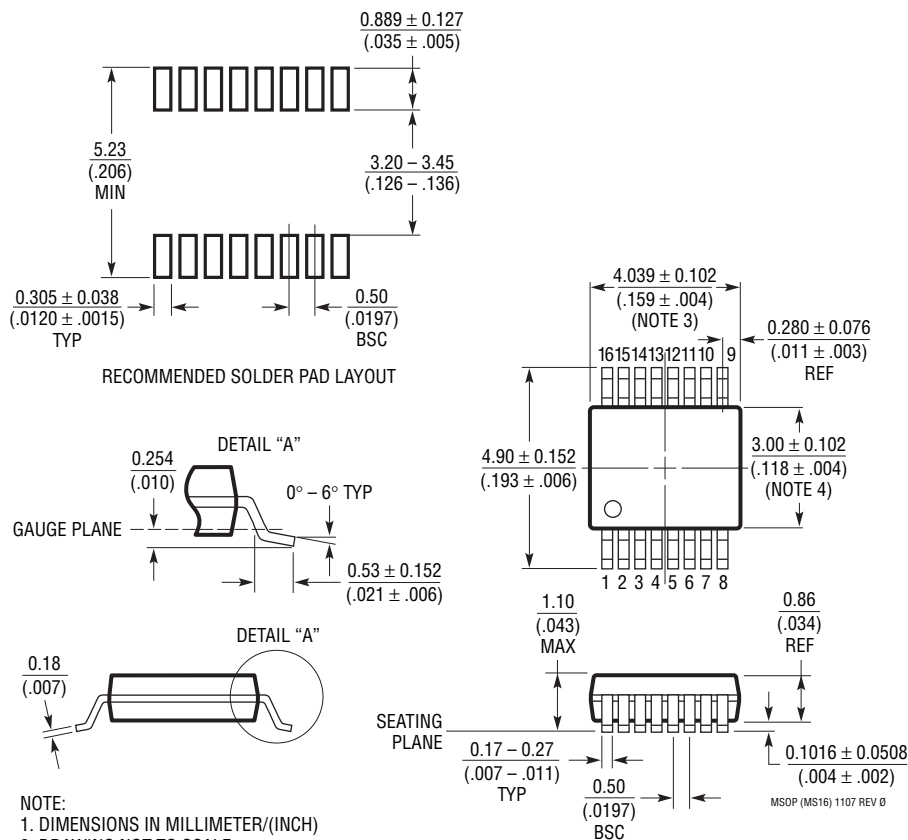

- NOTE:
1. DIMENSIONS IN MILLIMETER/(INCH)
 2. DRAWING NOT TO SCALE
 3. DIMENSION DOES NOT INCLUDE MOLD FLASH, PROTRUSIONS OR GATE BURRS.
MOLD FLASH, PROTRUSIONS OR GATE BURRS SHALL NOT EXCEED 0.152mm (.006") PER SIDE
 4. DIMENSION DOES NOT INCLUDE INTERLEAD FLASH OR PROTRUSIONS.
INTERLEAD FLASH OR PROTRUSIONS SHALL NOT EXCEED 0.152mm (.006") PER SIDE
 5. LEAD COPLANARITY (BOTTOM OF LEADS AFTER FORMING) SHALL BE 0.102mm (.004") MAX

MSOP (MS16) 1107 REV 0

TYPICAL APPLICATION

1.2V Load Share

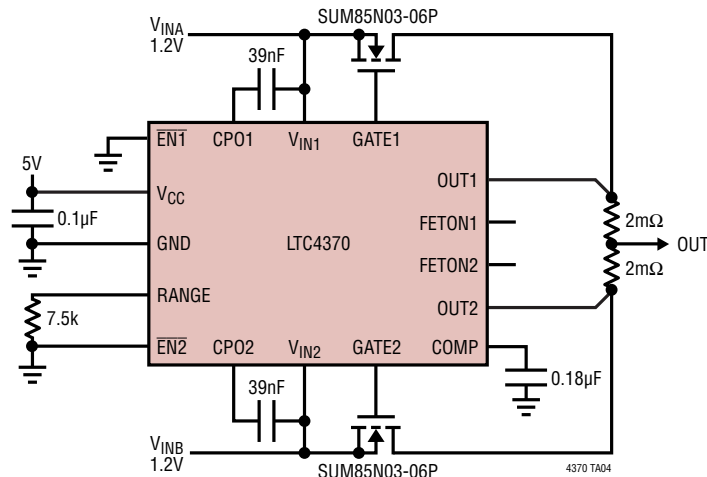

RELATED PARTS

PART NUMBER	DESCRIPTION	COMMENTS
LTC1473/ LTC1473L	Dual PowerPath™ Switch Driver	N-Channel, 4.75V to 30V/3.3V to 10V, SSOP-16 Package
LTC1479	PowerPath Controller for Dual Battery Systems	Three N-Channel Drivers, 6V to 28V, SSOP-36 Package
LTC4352	Low Voltage Ideal Diode Controller with Monitoring	N-Channel, 0V to 18V, UV, OV, MSOP-12 and DFN-12 Packages
LTC4353	Dual Low Voltage Ideal Diode Controller	Dual N-Channel, 0V to 18V, MSOP-16 and DFN-16 Packages
LTC4354	Negative Voltage Diode-OR Controller and Monitor	Dual N-Channel, -4.5V to -80V, SO-8 and DFN-8 Packages
LTC4355	Positive High Voltage Ideal Diode-OR with Supply and Fuse Monitors	Dual N-Channel, 9V to 80V, SO-16 and DFN-14 Packages
LTC4357	Positive High Voltage Ideal Diode Controller	N-Channel, 9V to 80V, MSOP-8 and DFN-6 Packages
LTC4358	5A Ideal Diode	Internal N-Channel, 9V to 26.5V, TSSOP-16 and DFN-14 Packages
LTC4411	2.6A Low Loss Ideal Diode in ThinSOT™	Internal P-Channel, 2.6V to 5.5V, 40µA I _Q , SOT-23 Package
LTC4412/ LTC4412HV	Low Loss PowerPath Controller in ThinSOT	P-Channel, 2.5V to 28V/36V, 11µA I _Q , SOT-23 Package
LTC4413/ LTC4413-1	Dual 2.6A, 2.5V to 5.5V, Ideal Diodes in DFN-10	Dual Internal P-Channel, 2.5V to 5.5V, DFN-10 Package
LTC4414	36V Low Loss PowerPath Controller for Large P-Channel MOSFETs	P-Channel, 3V to 36V, 30µA I _Q , MSOP-8 Package
LTC4415	Dual 4A Ideal Diodes with Adjustable Current Limit	Dual P-Channel 50mΩ Ideal Diodes, 1.7V to 5.5V, 15mV Forward Drop, MSOP-16 and DFN-16 Packages
LTC4416/ LTC4416-1	36V Low Loss Dual PowerPath Controller for Large P-Channel MOSFETs	Dual P-Channel, 3.6V to 36V, 70µA I _Q , MSOP-10 Package

Looking for pricing, stock, or lifecycle information?

Click below to explore more details on WIN SOURCE:

 [View LTC4370IDE#PBF on WIN SOURCE](#)

 [Linear Technology](#) Information

Optimize Your Supply Chain with WIN SOURCE Solutions

-  Global Sourcing Solution
-  Obsolete Management
-  Cost Control Management
-  Shortage Management
-  Alternative Solution
-  Excess Inventory Management