



**THE DATASHEET OF
LTC4420CMSE#PBF**



18V Dual Input Micropower PowerPath Prioritizer with Backup Supply Monitoring

FEATURES

- Selects Highest Priority Valid Supply from Two Inputs
- Wide 1.8V to 18V Operating Range
- Internal Dual 2Ω, 0.5A Switches
- Low 3.6μA Operating Current
- Low 320nA V2 Current When V1 Connected to OUT
- Blocks Reverse and Cross Conduction Currents
- Reverse Supply Protection to -15V
- Built-In V2 Test with Optional V2 Disconnect
- V2 Freshness Seal/Ship Mode
- ±1.5% Accurate Adjustable Switchover Threshold
- ±2.3% Accurate V2 Monitor and Comparator
- Overcurrent and Thermal Protection
- Thermally Enhanced 12-Pin 3mm × 3mm DFN and 12-Lead Exposed Pad MSOP Packages

APPLICATIONS

- Low Power Battery Backup
- Portable Equipment
- Point-of-Sale (POS) Equipment

DESCRIPTION

The LTC[®]4420 is a dual input monolithic PowerPath™ prioritizer, with low operating current, that provides backup switchover for keeping critical circuitry alive during brownout and power loss conditions. Unlike diode-OR products, little current is drawn from the inactive supply even if its voltage is greater than the active supply.

Internal 2Ω, current limited PMOS switches provide power path selection from a primary input (V1) or a backup input (V2) to the output. Two adjustable voltage monitors set via external resistive dividers provide flexibility in setting V1 to V2 switchover and V2 undervoltage thresholds. V1 is monitored continuously while V2 supply monitoring includes controllable low duty cycle UV monitoring. When primary input V1 drops, the ADJ monitor causes OUT to be switched to V2. When V2 drops, it is disconnected from OUT if V2DIS is low. Fast non-overlap switchover circuitry prevents reverse and cross conduction while minimizing output droop.

Auxiliary voltage monitor CMP1 provides flexible voltage monitoring and output V2OK provides V2 undervoltage status. Freshness seal mode prevents V2 battery discharge during storage or shipment.

LT, LT, LTC, LTM, Linear Technology and the Linear logo are registered trademarks and PowerPath and ThinSOT are trademarks of Analog Devices, Inc. All other trademarks are the property of their respective owners.

TYPICAL APPLICATION

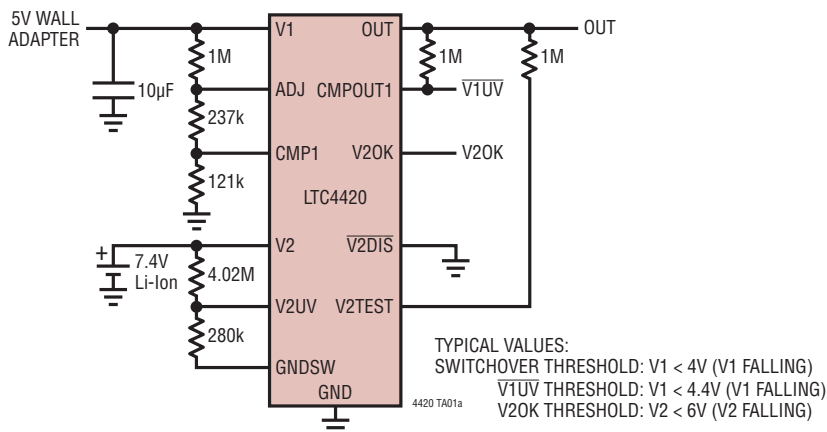

Typical Switchover Waveforms

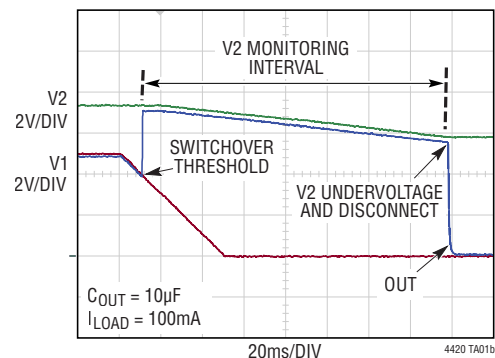

LTC4420

ABSOLUTE MAXIMUM RATINGS (Notes 1, 2)

Terminal Voltages

V1, V2	-15V to 24V
OUT	-0.3V to 24V
OUT - V2	-24V to 39V
OUT - V1	-24V to 39V

Input Voltages

ADJ, CMP1, V2UV, V2TEST, $\overline{V2DIS}$ (Note 3)	-0.3V to 24V
---	--------------

Output Voltages

CMPOUT1, GNDSW, V2OK (Note 3)	-0.3V to 24V
-------------------------------------	--------------

Pin Currents (Note 2)

ADJ, CMP1, V2UV, CMPOUT1, GNDSW	-1mA
V2TEST, $\overline{V2DIS}$, V2OK	-1mA

Operating Ambient Temperature Range

LTC4420C	0°C to 70°C
LTC4420I	-40°C to 85°C

Junction Temperature (Notes 4, 5)

125°C

Storage Temperature Range

-65°C to 150°C

Lead Temperature (Soldering, 10 sec)

MSOP Package 300°C

PIN CONFIGURATION

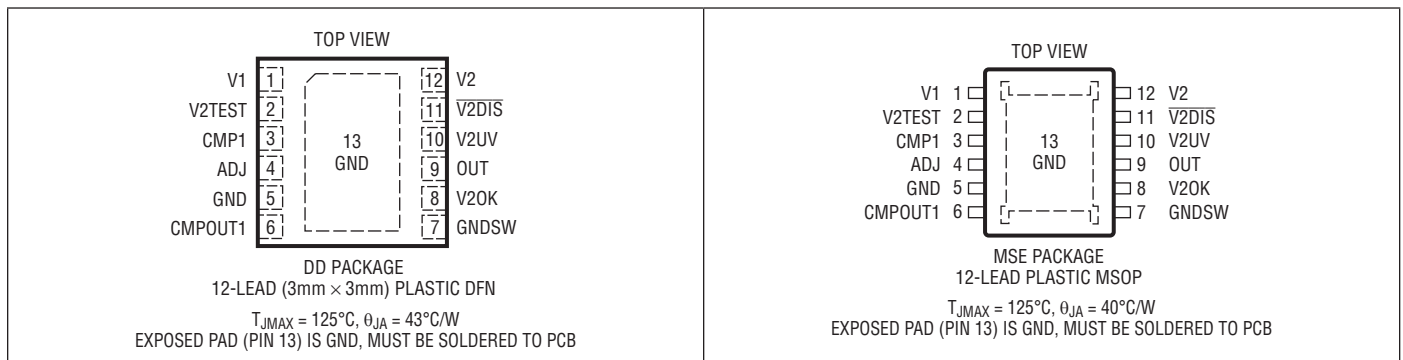

ORDER INFORMATION <http://www.linear.com/product/LTC4420#orderinfo>

LEAD FREE FINISH	TAPE AND REEL	PART MARKING*	PACKAGE DESCRIPTION	TEMPERATURE RANGE
LTC4420CDD#PBF	LTC4420CDD#TRPBF	LGMR	12-Lead (3mm × 3mm) Plastic DFN	0°C to 70°C
LTC4420IDD#PBF	LTC4420IDD#TRPBF	LGMR	12-Lead (3mm × 3mm) Plastic DFN	-40°C to 85°C
LTC4420CMSE#PBF	LTC4420CMSE#TRPBF	4420	12-Lead Plastic Exposed Pad MSOP	0°C to 70°C
LTC4420IMSE#PBF	LTC4420IMSE#TRPBF	4420	12-Lead Plastic Exposed Pad MSOP	-40°C to 85°C

Consult LTC Marketing for parts specified with wider operating temperature ranges. *The temperature grade is identified by a label on the shipping container.

For more information on lead free part marking, go to: <http://www.linear.com/leadfree/>

For more information on tape and reel specifications, go to: <http://www.linear.com/tapeandreeel/>. Some packages are available in 500 unit reels through designated sales channels with #TRMPBF suffix.

ELECTRICAL CHARACTERISTICS The ● denotes the specifications which apply over the full operating temperature range, otherwise specifications are at $T_A = 25^{\circ}\text{C}$. V1 = 3.6V, V2 = 3.6V unless otherwise noted.

SYMBOL	PARAMETER	CONDITIONS	MIN	TYP	MAX	UNITS
V1, V2	Operating Voltage Range		● 1.8		18	V
I_{V1}	V1 Current, V1 Powering OUT V1 Current, V2 Powering OUT	$I_{OUT} = 0$, V1 = 8.4V, V2 = 3.6V V1 = 8.4V, V2 = 3.6V	●	3.6	6.3	μA
			●	500	800	nA

4420fa

ELECTRICAL CHARACTERISTICS

The ● denotes the specifications which apply over the full operating temperature range, otherwise specifications are at $T_A = 25^\circ\text{C}$. $V_1 = 3.6\text{V}$, $V_2 = 3.6\text{V}$ unless otherwise noted.

SYMBOL	PARAMETER	CONDITIONS		MIN	TYP	MAX	UNITS
I_{V2}	V2 Current, V2 Powering OUT V2 Current, V1 Powering OUT V2 Current in Freshness Seal Mode	$I_{OUT} = 0$, $V_1 = 3.6\text{V}$, $V_2 = 8.4\text{V}$ $V_1 = 3.6\text{V}$, $V_2 = 8.4\text{V}$ $V_1 = \text{GND}$, $V_2 = 5\text{V}$	●		3.3	6	μA
			●		320	650	nA
			●		120	220	nA
R_{ON}	Switch Resistance	$V_1 = V_2 = 5\text{V}$, $I_{OUT} = -100\text{mA}$	●	1	2	5	Ω
$t_{VALID(V1)}$	Input Qualification Time	V_1 Rising, ADJ Rising	●	34	64	94	ms

Input Comparators

V_{THA}	ADJ Threshold	ADJ Falling	●	1.032	1.047	1.062	V
V_{HYSTA}	ADJ Comparator Hysteresis	ADJ Rising	●	30	50	70	mV
V_{THC}	CMP1, V2UV Threshold	CMP1, V2UV Falling	●	0.378	0.387	0.396	V
V_{HYSTC}	CMP1, V2UV Comparator Hysteresis	CMP1, V2UV Rising	●	7.5	10	12.5	mV
t_{PDA}	ADJ Comparator Falling Response Time	10% Overdrive	●	4	7.3	12	μs
t_{PDC}	CMP1, V2UV Comparator Response Times	20% Overdrive	●		30	65	μs

Power Path Function

I_{LIM}	Output Current Limit	$V_1, V_2 = 8.4\text{V}$	●	0.5	1.1	1.6	A
V_{REV}	Reverse Comparator Threshold	$(V_1, V_2) - V_{OUT}$ for Power Path Turn-On	●	25	50	75	mV
t_{SWITCH}	Break-Before-Make Switchover Time	$V_1 = V_2 = 5\text{V}$, $I_{OUT} = -100\text{mA}$	●	1	2.5	5	μs

V2 Monitoring

t_{MONL}	Longest Possible V2UV Monitor Duration	$V_2\text{TEST} \geq V_{IH}$	●	88	128	168	ms
t_{MONS}	Shortest Possible V2UV Monitor Duration	$V_2\text{TEST} \geq V_{IH}$	●	1	2	3	ms
t_{LTEST}	Time Between V2UV Monitoring Events	$V_2\text{TEST} \geq V_{IH}$	●	80	132	180	s
t_{HV2T}	Minimum Allowed V2TEST High Time	V2TEST Driven Externally	●	10			ms
t_{LV2T}	Minimum Allowed V2TEST Low Time	V2TEST Driven Externally	●	10			ms

I/O Specifications

V_{OL}	Output Voltage Low, CMPOUT1, GNDSW and V2OK	$I = 100\mu\text{A}$ $I = 1\text{mA}$	●		15	50	mV
			●		120	250	mV
V_{OH}	V2OK Output High Voltage	$I = -1\mu\text{A}$, $V_2 = 5\text{V}$	●	1.05	1.65	2.3	V
I_{OH}	V2OK, GNDSW, CMPOUT1 Output High Leakage	CMPOUT1, GNDSW, V2OK = 18V	●		± 50	± 150	nA
V_{IL}	V2DIS, V2TEST Input Low Voltage	$V_1 = V_2 = 5\text{V}$	●			0.2	V
V_{IH}	V2DIS, V2TEST Input High Voltage	$V_1 = V_2 = 5\text{V}$	●	0.9			V
$I_{V2X(IN,Z)}$	V2DIS, V2TEST Allowable Leakage in Open State		●			0.5	μA
$I_{PU(V2OK)}$	V2OK Pull-Up Current	$V_2 = 5\text{V}$, ADJ = 0V, V2OK = 0V	●	-2.7	-5	-8	μA
I_{LEAK}	ADJ, CMP1, V2UV Leakage Current	ADJ, CMP1, V2UV = 0V, 1.5V	●		± 1	± 5	nA

Note 1: Stresses beyond those listed under Absolute Maximum Ratings may cause permanent damage to the device. Exposure to any Absolute Maximum Rating condition for extended periods may affect device reliability and lifetime.

Note 2: All currents into pins are positive; all voltages are referenced to GND unless otherwise noted.

Note 3: These pins can be tied to voltages down to -5V through a resistor that limits the current to less than -1mA .

Note 4: The LTC4420 includes overtemperature protection that is intended to protect the device during momentary overload conditions. Junction

temperature will exceed 125°C when overtemperature protection is active. Continuous operation above the specified maximum operating junction temperature may impair device reliability.

Note 5: The LTC4420 is tested under pulsed load conditions such that $T_J \approx T_A$. The junction temperature (T_J in $^\circ\text{C}$) is calculated from the ambient temperature (T_A in $^\circ\text{C}$) and power dissipation (P_D in Watts) according to the formula:

$$T_J = T_A + (P_D \cdot \theta_{JA})$$

TYPICAL PERFORMANCE CHARACTERISTICS

($T_A = 25^\circ\text{C}$, $V_1 = V_2 = 3.6\text{V}$ unless otherwise indicated)

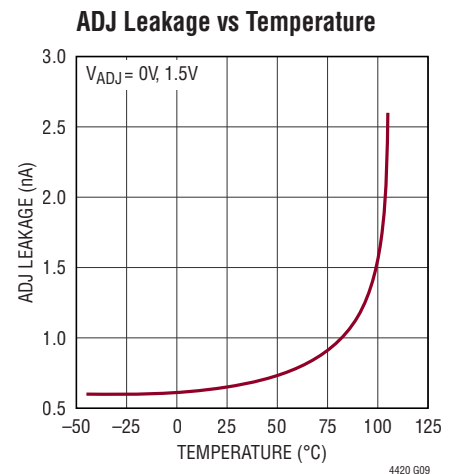
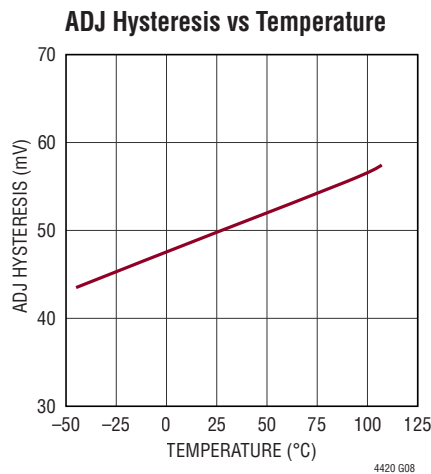
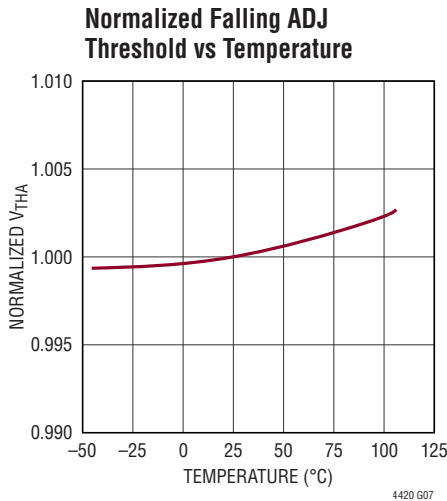
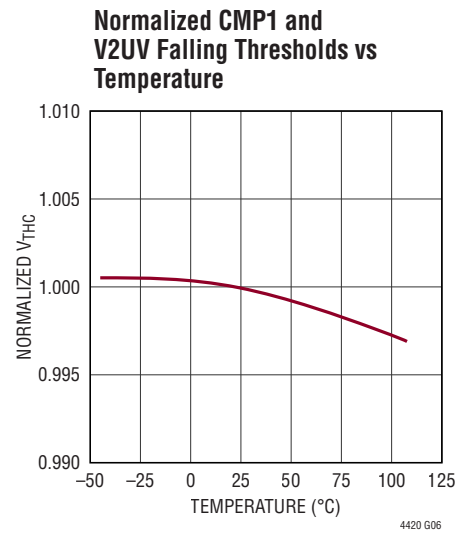
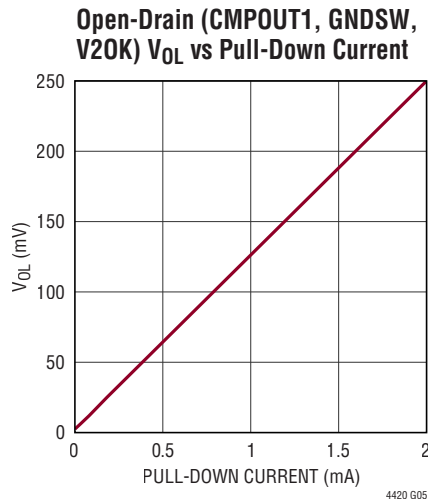
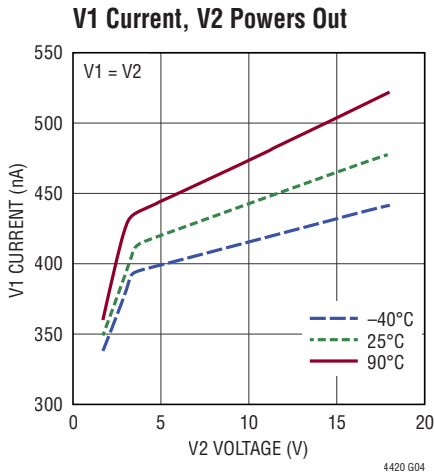
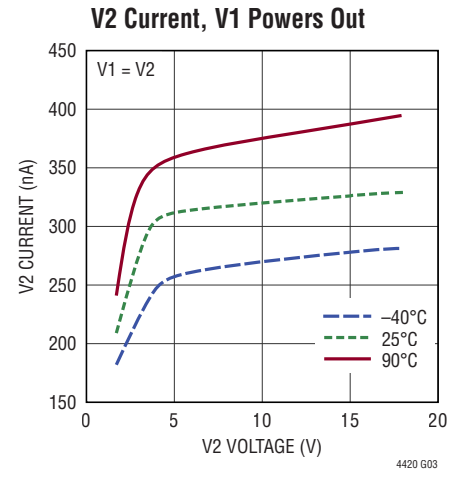
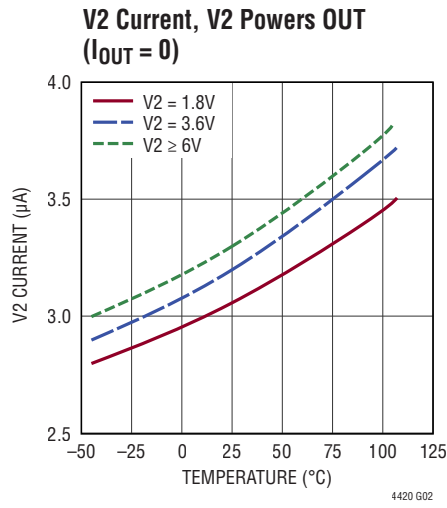
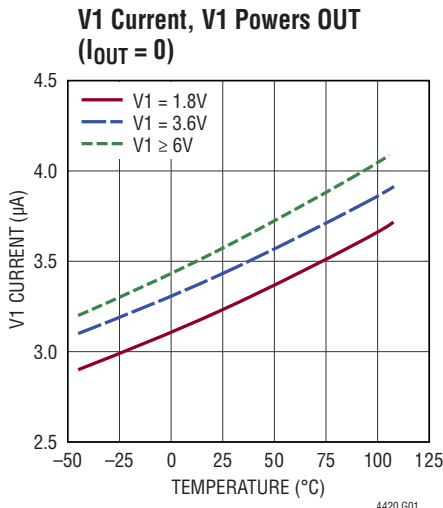

TYPICAL PERFORMANCE CHARACTERISTICS

($T_A = 25^\circ\text{C}$, $V_1 = V_2 = 3.6\text{V}$ unless otherwise indicated)

Output Current Limit vs Temperature

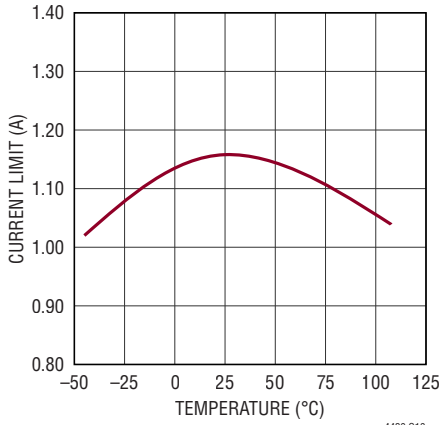

Output Current I_{OUT} Response for Different Shorting Impedances

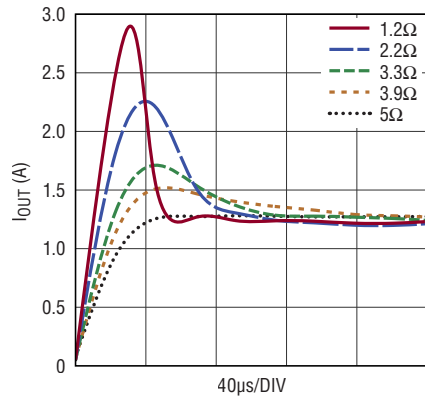

I_{OUT} vs V_{OUT} for Different Input Supply Voltages

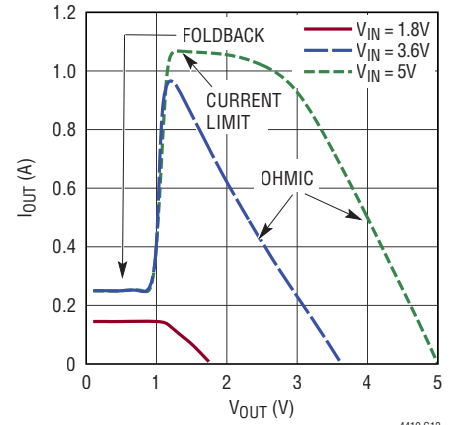

Switch R_{ON} vs Temperature

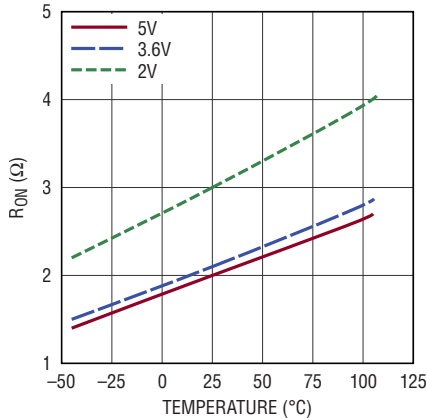

Freshness Seal Current vs V_2 Voltage and Temperature

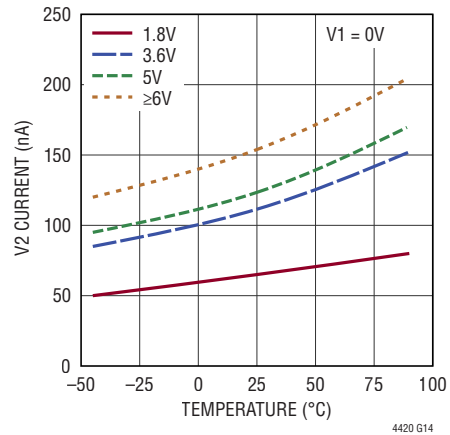

Switchover from a Higher to a Lower Voltage

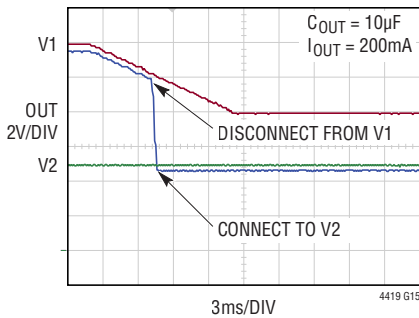

Output Voltage and Current Waveforms During Switchover

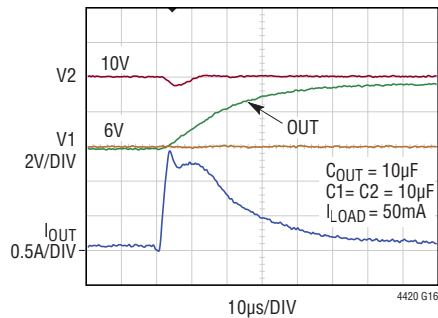

V_1 Reverse Voltage Blocking with V_2 Powering Out

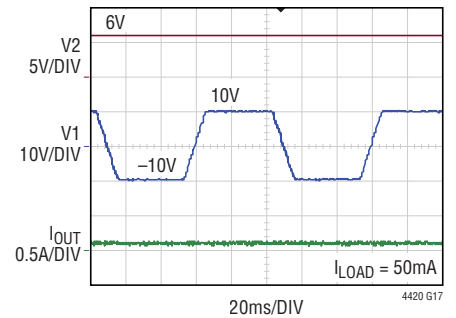

PIN FUNCTIONS

ADJ: Adjustable Switchover Threshold Input. ADJ is the noninverting input to the switchover threshold comparator. If $V1 \geq 1.55V$ and $ADJ \geq 1.097V$ for at least 64ms, OUT is switched internally to the primary V1 input. When the ADJ input voltage is lower than 1.047V, OUT is switched internally to V2 if conditions in Table 1 of the Applications Information section are met. Otherwise, OUT stays unpowered. Tie ADJ via a resistive divider to V1, in order to set the V1 to V2 switchover voltage. Do not leave open.

CMP1: Auxiliary Comparator 1 Monitor Input. CMP1 is the noninverting input to an auxiliary comparator. The inverting input is internally connected to a 0.387V reference. Connect CMP1 to GND when it is not used.

CMPOUT1: Auxiliary Comparator Output 1. This open-drain comparator output is pulled low when CMP1 is below 0.387V and during power-up, otherwise it is released. Once released, connecting a resistor between CMPOUT1 and a desired supply voltage up to 18V causes this pin to be pulled high. Leave open if unused.

GNDSW: Pulsed GND Output. This open-drain output is pulled low when V2UV is being monitored, otherwise it is released high. Connect a resistive divider between V2, V2UV and GNDSW to set V2 undervoltage threshold. Leave open if unused.

Exposed Pad: The exposed pad is ground and must be soldered to the PCB ground plane.

GND: Device Ground.

OUT: Output Voltage Supply. OUT is a prioritized voltage output that is either connected to V1, V2 or is unpowered as indicated in Table 1 of the Applications Information section. Additionally, OUT must be at least 50mV below the input supply for a connection to that supply to be activated. Bypass with a capacitor of 1 μ F or greater. See Applications Information for bypass capacitor recommendations.

V1: Primary Power Supply. OUT is internally switched to V1 if $V1 \geq 1.55V$ and $ADJ \geq 1.097V$. When in freshness seal, applying $V1 \geq 1.55V$ and $ADJ \geq 1.097V$ for 32ms disables freshness seal. Bypass with 1 μ F or greater. Tie to GND if unused.

V2: Backup Power Supply. OUT is internally switched to V2 if $ADJ < 1.047V$ or $V1 < 1.55V$, provided other conditions listed in Table 1 in Applications Information are met. Bypass with 1 μ F or greater. Tie to GND if unused.

V2DIS: V2 Power Path Disable Input. When driven low, this pin disables the V2 to OUT power path if input V2UV drops below 0.387V. Connect a resistor between V2 or OUT and this pin to provide additional pull-up. Leave open if unused. This pin is initialized high during power-up.

V2OK: V2OK Logic Output. V2OK is an output that is driven high with a 5 μ A pull-up if $V2UV > 0.387V$ at the end of the V2UV monitoring period. Otherwise it is driven low. Connect a resistor between OUT and this pin to provide additional pull-up. As this pin is used to enable freshness seal, do not force low or connect a pull-down resistor to this pin. Leave open if unused.

V2TEST: V2 Undervoltage Test Enable Input. This pin sets the duty cycle of V2 undervoltage monitoring. When V1 is valid, driving V2TEST low disables V2 monitoring while driving it high enables V2 monitoring with a maximum duty cycle of ~0.1%. When V1 is invalid or not present, V2 is always monitored with V2TEST setting the duty cycle between 0.0015% and 0.1% depending on its own state and previously determined V2 validity. Refer to the state diagram and waveforms in the Applications Information section for details. Leave open or connect a resistor between V2 or OUT and this pin to provide additional pull-up. Connect to GND if unused. This pin is initialized high on power-up.

V2UV: V2 Undervoltage Monitor Input. V2UV is the noninverting input to a comparator whose inverting input is internally connected to a 0.387V reference. Connect a resistive divider between V2, V2UV and GNDSW to set V2 undervoltage threshold. See the Applications Information section for details on V2 monitoring. Connect a pull-up resistor to V2 if unused. Do not leave open.

FUNCTIONAL DIAGRAM

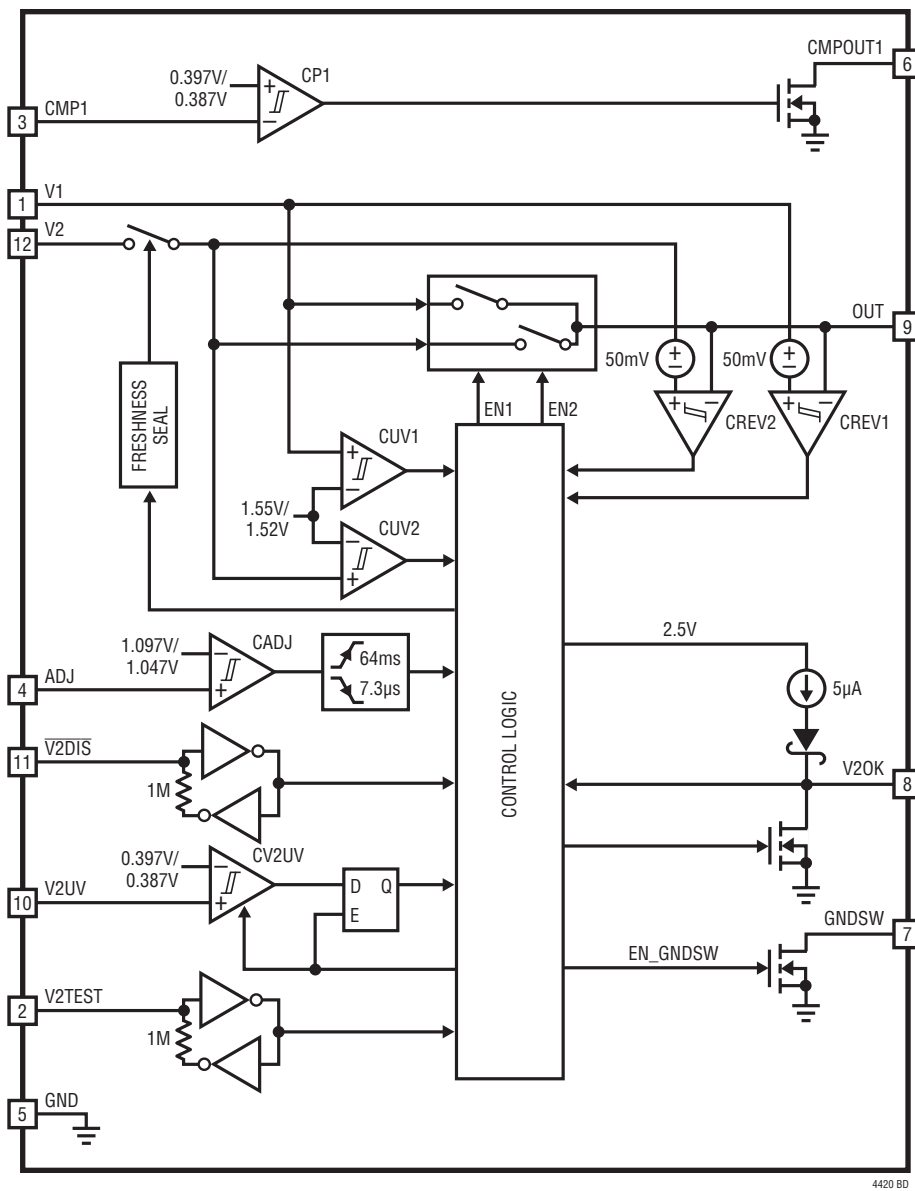

4420 BD

OPERATION

The Functional Diagram shows the major blocks of the LTC4420. The LTC4420 is a PowerPath prioritizer that switches output OUT between primary (V1) and backup (V2) sources depending on their validity and priority with V1 having the highest priority. A resistive divider between V1, ADJ and GND and comparators CUV1 and CADJ are used to monitor V1's voltage to establish validity. V1 is valid if $V1 \geq 1.55V$ and $ADJ \geq 1.097V$ for 64ms after V1 rises above 1.55V. Otherwise V1 is invalid. A resistive divider between V2, V2UV and GNDSW and comparators CUV2 and CV2UV are used to monitor V2's voltage to establish validity. V2 voltage is monitored periodically in order to minimize current consumption in the divider. V2 is valid if $V2 \geq 1.55V$ and $V2UV \geq 0.4V$ at the end of the V2 monitoring period. Otherwise it is invalid. If neither supply is valid, OUT stays unpowered if $\overline{V2DIS}$ is low. If $\overline{V2DIS}$ is high and $V2 > 1.55V$, OUT is connected to V2. Refer to Table 1 in the Applications Information section for details. Switchover threshold is independent of relative V1 and V2 voltages, permitting V1 to be lower or higher than V2 when V1 powers OUT and vice versa.

Power connection to the output is made by enhancing back-to-back internal P-channel MOSFETs. Current passed by the MOSFETs is limited to typically 1.1A if OUT is greater than 1V. Otherwise it is limited to 250mA. When switching from V1 to V2, the V1 to OUT power path is first disabled and comparator CREV2 is enabled. After the OUT voltage drops 50mV below V2, as detected by CREV2, OUT is then connected to V2. This break-before-make strategy prevents OUT from backfeeding V2. Switchover back to V1 occurs in a similar manner once V1 has been revalidated.

The LTC4420 blocks reverse voltages up to $-15V$ when a reverse condition occurs on an inactive channel. The LTC4420 also disables a channel if the corresponding input supply falls below 1.52V. A small $\sim 3\mu A$ current is drawn from either the prioritized input supply, or the highest supply if both input supplies are below 1.55V. Very little current ($\sim 320nA$) is drawn from the unused supply.

Pins V2TEST and $\overline{V2DIS}$ provide flexibility in monitoring and disconnecting the V2 power path using the V2UV monitor input. V2 is monitored by activating the V2-V2UV-GNDSW resistive divider. V2TEST allows for adjustability of GNDSW duty cycle to trade off V2 quiescent current with V2 monitoring frequency. When low, $\overline{V2DIS}$ disables the V2 to OUT power path, if V2 is found to be invalid. Refer to the Applications Information section for details. If V2 is valid at the end of a V2 monitoring interval, output V2OK is latched high. Otherwise it is latched low. V2OK retains its state until the end of the next V2 monitoring interval when it gets updated. V2 monitoring is disabled if $V2 < 1.55V$ or during thermal shutdown. During initial power-up V2 monitoring is disabled and V2OK is initialized low.

The LTC4420 provides an additional comparator, CP1, whose open-drain output pulls low either when the CMP1 pin voltage falls below 0.387V or during initial power up. This comparator can be used to monitor supplies to provide early power failure warning and other useful information.

The LTC4420 can be put into a V2 freshness seal mode to prevent battery discharge during storage or shipment. The Applications Information section lists the steps to engage and disengage V2 freshness seal.

APPLICATIONS INFORMATION

The LTC4420 is a low quiescent current 2-channel prioritizer that powers both its internal circuitry and its output OUT from a prioritized valid input supply. Unlike an ideal diode-OR, the LTC4420 does not necessarily draw current from the highest supply as long as one supply is greater than 1.8V. Table 1 lists the input supply from which the LTC4420 draws its internal quiescent current I_{CC} and the supply to which OUT is connected after input supplies have been qualified.

A typical battery backup application is shown in Figure 1. V1 is powered by a 2-cell Li-Ion battery pack whose safe discharge limit is between 5.6V and 6V. V2 is powered by a low self discharge 7.6V Li-Thionyl Chloride (Li-SOCl₂) hold-up battery which is completely discharged when its voltage drops to 6V. Li-SOCl₂ battery life is maximized as very little current is drawn from V2 during normal operation due to the low duty cycle of V2 monitoring and the LTC4420's low V2 standby current. To protect the 2-cell Li-Ion battery on V1, switchover threshold is set to be ~5.6V. After switchover to V2, the Li-Ion battery primarily supplies only divider R1-R3's current as the LTC4420 draws only a small standby current from V1. Monitor CMP1 is configured to provide V1 power failure warning by driving $\overline{V1UV}$ low when V1 falls below 6V. Monitor input V2UV is configured to set V2's UV threshold to 6V and $\overline{V2DIS}$ is tied low to disconnect the V2 to OUT power path when V2 falls below 6V. V2TEST is tied high to monitor V2 once every 132s. Relevant equations used to calculate these component values are discussed in the following subsections.

Table 1. OUT and LTC4420 I_{CC} Power

INPUT VOLTAGES					I_{CC} SOURCE	OUT CONNECTION
V1 > 1.55V	ADJ > 1.097V	V2 > 1.55V	$\overline{V2DIS}$ > 0.9V	V2UV > 0.397*		
Y†	Y†	X	X	X	V1	V1
Y	N	Y	Y	X	V2	V2
Y	N	Y	N	Y	V2	V2
Y	N	Y	N	N	V1	Hi-Z
Y	N	N	X	X	V1	Hi-Z
N	X	Y	N	N	V2	Hi-Z
N	X	Y	Y	Y	V2	V2
N	X	Y	Y	X	V2	V2
N	X	N	X	X	V_{MAX}^{**}	Hi-Z

*Note: Refers to V2UV voltage at the end of the V2 monitoring period.

**Note: V_{MAX} = higher of V1 and V2.

† For 64ms.

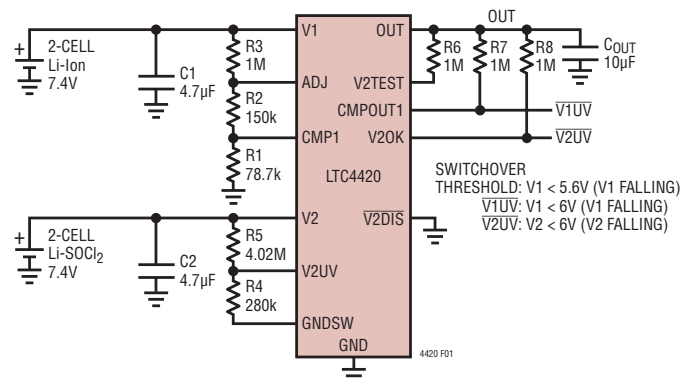

Figure 1. The LTC4420 Protecting 2-Cell Lithium Battery Packs on V1 and V2 from Discharge Below Their Safe Minimum Voltage

Setting Switchover and V2 Undervoltage Thresholds

Several factors affect switchover voltage and should be taken into account when calculating resistor values. These include resistor tolerance, 1.5% ADJ comparator threshold error, divider impedance and worst-case ADJ pin leakage. These factors also apply to resistive dividers connected to monitor inputs CMP1 and V2UV. Referring to Figure 1 and the Electrical Characteristics table, the typical V1 switchover threshold:

$$V_{SW1} = \frac{V_{THA}}{R1+R2} \cdot (R1+R2+R3) \quad (1)$$

APPLICATIONS INFORMATION

Typical V1 undervoltage threshold is:

$$V_{V1UV} = \frac{V_{THC}}{R1} \cdot (R1 + R2 + R3) \quad (2)$$

Worst-case V_{OL} due to current flow into the GNDSW pin must be taken into account while calculating values for the V2 undervoltage resistive divider:

$$V_{V2UV} = \frac{V_{THC}}{R4 + \frac{V_{OL}}{100\mu A}} \cdot \left(R4 + R5 + \frac{V_{OL}}{100\mu A} \right) \quad (3)$$

Equations 1-3 assume ADJ and CMP1 pin leakages are negligible. To account for pin leakage, equations 1-3 must be modified by an $I_{LEAK} \cdot R_{EQ}$ term where equivalent resistance R_{EQ} must be calculated on a case-by-case basis. Worst-case component values and reference voltage tolerances must be used to calculate the maximum and minimum threshold voltages. For example, to calculate minimum falling switchover threshold voltage $V_{SW1(MIN)}$, use $V_{THA(MIN)}$, $(R2+R1)_{(MAX)}$, $R3_{(MIN)}$ in equation 1.

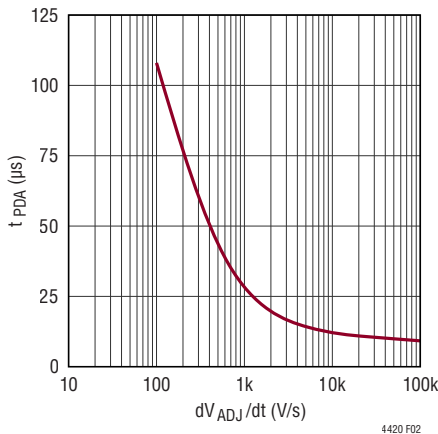

Figure 2. ADJ Comparator Propagation Delay as a Function of Slew Rate; t_{PDA} vs dV_{ADJ}/dt

Selecting Output Capacitor C_{OUT}

C_{OUT} can be selected to control either output voltage droop during switchover or output rising slew rate during initial power-up or when switching to a higher supply.

In general, output droop, ΔV_{OUT} , can be calculated by:

$$V_{OUT} = \frac{t_{NOV} \cdot I_{OUT}}{C_{OUT}} \quad (4)$$

where I_{OUT} is the current supplied by C_{OUT} during non-overlap or dead time, t_{NOV} . Choosing:

$$C_{OUT} \geq \frac{t_{NOV} \cdot I_{OUT}}{\Delta V_{OUT}} \quad (5)$$

limits output droop to less than ΔV_{OUT} .

In order to estimate t_{NOV} and I_{OUT} , first consider a scenario where power supplies are present on V1 and V2, and their voltages are changing slowly compared to the ADJ comparator propagation delay t_{PDA} . For such cases, I_{OUT} is I_{LOAD} and t_{NOV} is t_{SWITCH} . C_{OUT} can be sized according to equation 5 with $I_{OUT} = I_{LOAD(MAX)}$ and $t_{NOV} = t_{SWITCH(MAX)}$ to limit maximum output droop when switching to a higher supply. When switching to a lower supply, switchover is initiated only after OUT falls V_{REV} below the supply that is being switched in. In such cases, total output droop is $\Delta V_{OUT} + V_{REV}$.

Next consider a scenario where the input power source powering OUT is unplugged. OUT backfeeds circuitry connected to the input supply pin. Both input and output droop at the same rate. Referring to Figure 1, assume the battery on V1 is unplugged when OUT is connected to V1. I_{OUT} is the sum of I_{LOAD} and the back fed current I_{BACK} , which in this example is I_{R3} . As OUT and V1, since the two are connected, droop below the ADJ threshold, switchover occurs to V2 with a dead time

$$t_{NOV} = t_{PDA} + t_{SWITCH} \quad (6)$$

where t_{PDA} is an overdrive dependent ADJ comparator delay. As an approximation, use t_{PDA} from the Electrical Characteristics table to estimate t_{NOV} . Use this t_{NOV} and:

$$I_{OUT} = (I_{BACK} + I_{LOAD}) \quad (7)$$

in equation 5 to size C_{OUT} :

$$C_{OUT} \geq \frac{(t_{PDA} + t_{SWITCH}) \cdot I_{OUT}}{\Delta V_{OUT}} \quad (8)$$

Refer to Figure 2 for a more accurate estimate of t_{PDA} vs dV_{OUT}/dt . If ADJ is filtered with capacitor C_{ADJ} , its discharge time via divider R1 – R3 increases t_{PDA} . This results in a higher output droop than estimated by equation (8).

APPLICATIONS INFORMATION

In order to limit output rising slew rate dV_{OUT}/dt , size:

$$C_{OUT} \geq \frac{I_{LIM}}{\frac{dV_{OUT}}{dt}} \quad (9)$$

as the LTC4420 limits OUT charging current to I_{LIM} until OUT approaches the input supply to within $I_{LIM} \cdot R_{ON}$, where R_{ON} is the channel switch resistance. Refer to the Thermal Protection and Maximum C_{OUT} section to determine maximum allowed C_{OUT} .

Inductive Effects

Parasitic inductance and resistance can impact circuit performance by causing overshoot and undershoot of input and output voltages when the LTC4420 turns off. Parasitic inductance in the power path causes positive-going overshoot on the input and a negative-going undershoot on the output. Another cause of positive input overshoot is R-L-C tank ringing during hot plug of an input supply. Input overshoot is most pronounced when the total resistance of the input tank is low. Care must be taken to ensure over voltage transients do not exceed the Absolute Maximum ratings of the LTC4420. Additionally, parasitic resistance and inductance can cause input undershoot (droop) during power path turn on. If severe enough, undershoot can temporarily invalidate a supply and cause repeated power up cycles (motorboating) or unwanted switchover between sources.

The first step to avoid these issues is to minimize parasitic inductance and resistance in the power path. Guidelines are given in the layout section for minimizing parasitic inductance on the printed circuit board (PCB). External to the PCB, twist the power and ground wires together to minimize inductance.

Second, use a bypass capacitor at the input to limit input voltage overshoot during LTC4420 power path turn off. A few micro farads is sufficient for most applications. When hot plugging supplies with large parasitic inductances, it is possible for the R-L-C tank to ring to more than twice the nominal supply voltage. Wall adapters and batteries typically have enough loss (i.e. series resistance) to prevent ringing of this magnitude. However, if this is a problem, snub input capacitor C_{SN1} with resistor R_{SN1} , typically 0.5Ω . Place this network close to the supply pin.

Third, if an input capacitor is not permissible, use a TVS (such as SMAJ16CA) in applications when supply pin transients can exceed 24V. Use a bidirectional TVS in applications requiring reverse input protection. Note that a TVS does not address droop and motorboating, which are solved only by input bypassing.

During normal operation, the LTC4420 limits power path current to $< 1.6A$ and internal circuitry prevents OUT from ringing below ground during power path turn off. This is also true for output shorts when the short is close to the LTC4420's OUT pin. However, if the output is shorted through a long wire, current in the wire inductance (L_{PAR2} in Figure 3) builds up due to the discharge of C_{OUT1} and can be much higher than 1.6A. This current causes the OUT pin to ring below its $-0.3V$ absolute maximum rating once C_{OUT1} has been fully discharged. For this special case, split the output capacitor between C_{OUT1} and C_{OUT2} and make C_{OUT1} small. Snub C_{OUT1} with resistor R_{SN2} to damp R-L-C ringing if required. Size C_{OUT2} to obtain the required total output capacitance. Also add a diode between OUT and ground close to the LTC4420 to clamp negative ringing if the OUT pin rings below $-0.3V$.

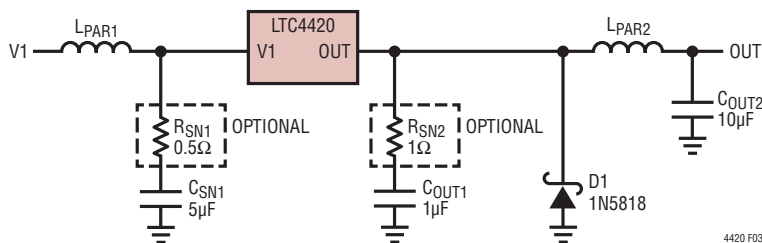

Figure 3. Recommended Inductive Transient Suppression Circuitry

APPLICATIONS INFORMATION

- To provide default battery backup monitoring and disconnect in systems where $V2TEST$ and $\overline{V2DIS}$ are not actively driven. $V2TEST$ and $\overline{V2DIS}$ are either tied high or low in these applications.
- To allow a system powered by OUT to shut itself down if there is no valid input supply.
- To support backup battery charging without having to disconnect the battery from the system.
- Handling exceptions such as initial power up, recovery from thermal shutdown and switchover after long intervals when V2 was not being monitored.

Configuring $V2TEST$ and $\overline{V2DIS}$

$V2TEST$ controls the duration of and the time between V2 monitoring events. It can either be tied high, low or actively driven based on the application. The following section explores common scenarios.

In applications where primary supply V1 is going to be valid for long periods of time and where $V2TEST$ can be actively driven, $V2TEST$ should generally be driven low and only pulsed high when V2 status is needed. This minimizes V2-V2UV-GNDSW divider current. This scenario also applies when V2 is a battery that slowly discharges over time, making a V2 status update every 132s superfluous. When operating off V2, $V2TEST$ may be pulsed at intervals shorter than 131s to check V2's validity especially after large load current spikes.

If $V2TEST$ cannot be actively driven, it should be tied to either V2 or OUT through a pull-up resistor. If V2 can be reversed, tie $V2TEST$ to OUT. Tying $V2TEST$ high ensures that V2 is monitored every 132s as long as $V2 > 1.55V$. V2 monitoring duration is 128ms when V2 is valid and reduces to 2ms if V2 becomes invalid. Use smaller resistors in the V2-V2UV-GNDSW divider if V2 is a battery that can develop a passivation layer when it is not being used. Larger V2 current helps break the passivation whenever the V2 divider is active.

In special cases where V2 needs to be monitored only when V1 goes invalid and when battery passivation is not an issue, tie $V2TEST$ low.

If automatic V2 disconnect is desired when a V2 UV event occurs, tie $\overline{V2DIS}$ low. Otherwise leave open or tie to either OUT or V2 through a pull up resistor. If V2 can be reversed, tie $\overline{V2DIS}$ to OUT. If $\overline{V2DIS}$ can be actively driven, driving it low some time after a V2 UV event (output V2OK goes low) allows systems powered by OUT to finish active tasks, backup data and initiate shutdown proceedings.

Actively Driving $V2TEST$

In Figure 5, $V2TEST$ is actively driven. When V1 powers up above switchover threshold V_{SW1} , it is qualified for 64ms after which the V1 to OUT power path is activated. When V2 rises above 1.55V, GNDSW is pulsed low for 128ms and V2UV is monitored, even though $V2TEST$ is low. V2 is found to be valid resulting in V2OK being driven high. As long as V1 remains valid, V2 is monitored only when $V2TEST$ is driven high with V2 monitoring time being the lower of either the $V2TEST$ high time or 128ms. Figure 5 shows two such monitoring events of durations $t1$ and $t2$ where $t1$ and $t2$ are less than 128ms. When V1 drops below V_{SW1} , OUT is switched to V2 and V2 validity is refreshed by monitoring it once for 128ms independent of the state of $V2TEST$. Following this, since V2 is the only valid supply, V2 is monitored for 2ms every 132s if $V2TEST$ is low or for 128ms every 132s if $V2TEST$ is high. If V2 becomes invalid and $\overline{V2DIS}$ is low, the V2 to OUT power path gets disabled.

$V2TEST$ Tied Low

Figure 6 shows voltage waveforms for the case where $V2TEST$ is tied low. When V2 powers up above 1.55V, GNDSW is pulsed low and V2 is monitored once for 128ms.

Simultaneously, the V2 to OUT power path is activated in order to allow a system powered by OUT to power itself up and drive $\overline{V2DIS}$ to a desired state. V2 is determined to be valid causing V2OK to be driven high and the V2 power path to remain activated. If V2 was determined to be invalid and $\overline{V2DIS}$ was low, V2's power path would have been disabled and V2OK pulled low after 128ms. Since both V1 and $V2TEST$ are low, V2 is monitored for 2ms every 132s. When V1 becomes valid, OUT is switched to V1 and V2 monitoring is halted until V1 becomes invalid.

APPLICATIONS INFORMATION

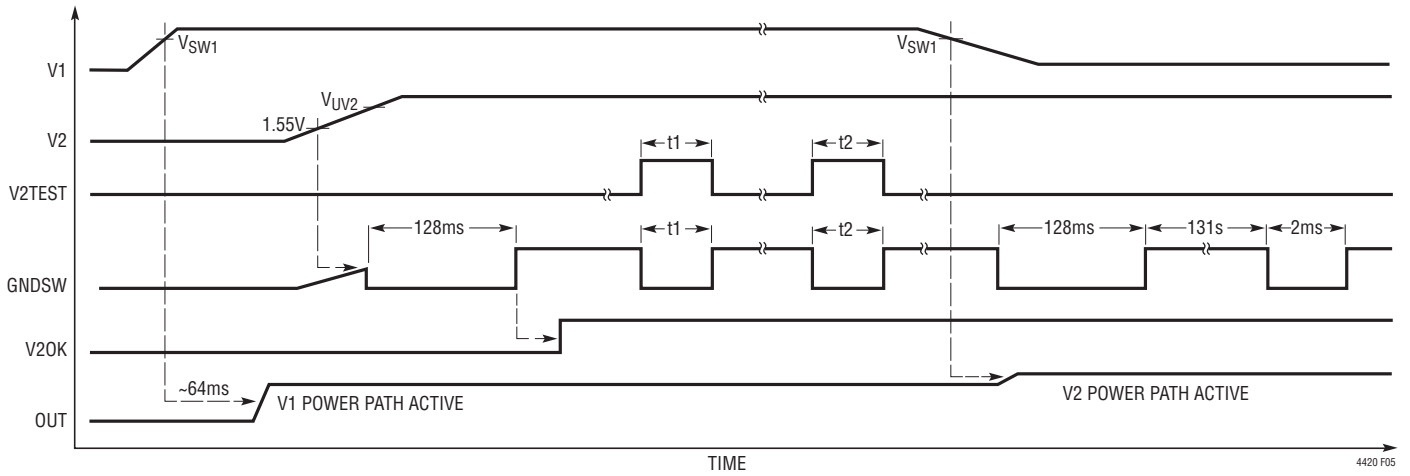

Figure 5. V2 Monitoring by Actively Driving VTEST. Note That t_1 and t_2 are $< 128\text{ms}$

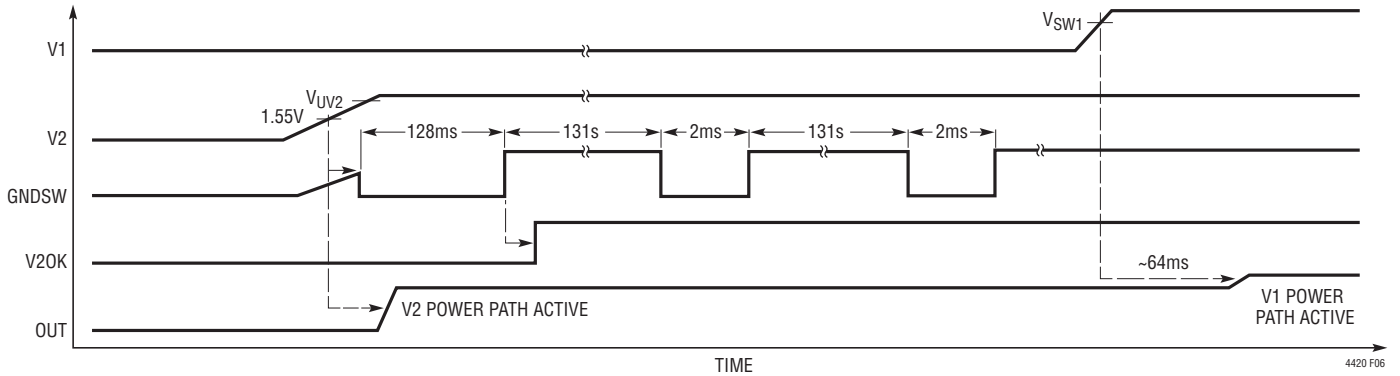

Figure 6. V2 Monitoring When V2TEST Is Low

APPLICATIONS INFORMATION

INCREASING CMP1 HYSTERESIS

In some applications, built in CMP1 hysteresis may be insufficient. In such cases, CMP1 hysteresis can be increased as shown in Figure 7. Hysteresis at the monitored input VMON with R8 present and assuming $R9 \ll R8$, is given by:

$$V_{HYST} = V_{HYSTC} \frac{R3}{R1 || R3 || R8} + V_{PU} \frac{R3}{R8} \quad (10)$$

where V_{HYSTC} is found in the electrical table and is typically 10mV. Account for supply V_{PU} and resistor R8 when calculating rising and falling thresholds of monitored input V_{MON} .

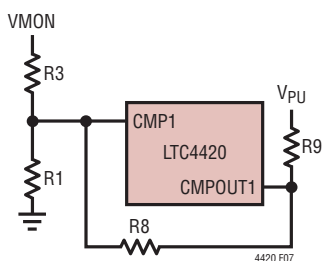

Figure 7. Increasing COMP1 Hysteresis

Supply Impedance and ADJ Comparator Hysteresis

In some applications, V1 could be supplied by a battery pack with high ESR or through a long cable with appreciable series resistance. Load current, I_{OUT} , flowing through this resistance reduces the monitored V1 voltage by:

$$\Delta V1 = I_{OUT} \cdot R_{ESR} \quad (11)$$

The drop can be as high as:

$$\Delta V1 = I_{LIM} \cdot R_{ESR} \quad (12)$$

when C_{OUT} is initially being charged. Voltage droop at the V1 pin can result in repeated switchover between V1 and V2 if built-in V1 (ADJ) hysteresis is insufficient.

Referring to Figure 1, in order to prevent switchover when C_{OUT} is being initially charged add input capacitor C1. Ideally, if V1 is greater than switchover threshold V_{SW1} by ΔV , size:

$$C1 > \frac{V_{SW1} \cdot C_{OUT} \cdot \left(1 - \frac{\Delta V}{2 \cdot I_{LIM} \cdot R_{ESR}} \right)}{\Delta V} \quad (13)$$

to ensure no switchover occurs when C_{OUT} is initially being charged. If the resulting C1 value causes large inrush current, is physically too big or requires a large snubber resistor when V1 is plugged (refer to the Typical Applications section), select C1 to be as high a value as the application can tolerate. A filter capacitor C_{ADJ} can also be added to ADJ, to ride through the initial output charge up time. C_{ADJ} should be minimized as it slows ADJ response, resulting in a larger output droop when the input supply powering V1 is either unplugged or drops quickly.

Input Shorts and Supply Brownout

The LTC4420 temporarily turns off its active power path during input shorts or brownout conditions if the input supply falls below OUT by 0.7V. If the primary input supply becomes invalid, switchover to the backup supply occurs. The power path is reactivated when the input recovers to within 0.7V of the output.

Figure 8 shows the response of the LTC4420 to a brown-out and recovery on V1 where switchover to V2 does not occur as V1 stays above 1.8V. When V1 falls, OUT gets disconnected from V1 and is slowly discharged by load resistance R_{OUT} . When V1 recovers, the power path is reactivated and OUT tracks V1. In Figure 9, when V1 falls, OUT gets disconnected from V1 as V1 drops below the switchover threshold. When V1 recovers, it needs to be qualified for 64ms before it is reconnected to OUT. OUT gets discharged by R_{OUT} and is connected to V2 once its voltage is 50mV less than V2.

APPLICATIONS INFORMATION

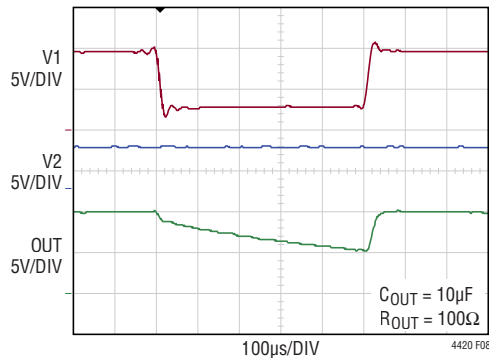

Figure 8. Voltage Waveforms During a Brownout on V1 That Does Not Result in Switchover to V2. Switchover Threshold = 1.8V

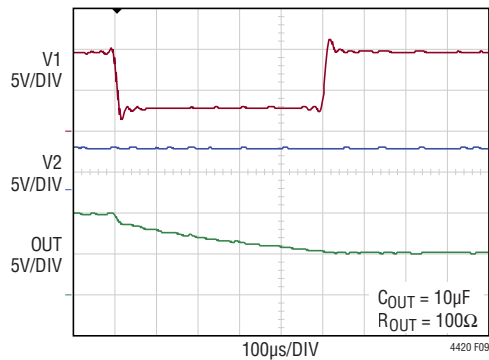

Figure 9. Voltage Waveforms When a Brownout on V1 Results in Switchover to V2. Switchover Threshold = 3V

Reverse Voltage Blocking

The LTC4420 blocks reverse voltages on supply pins V1 and V2 up to -15V relative to GND and up to -39V relative to OUT. Transient voltage suppressors (TVS) connected to V1 and V2 must be bidirectional and capacitors connected to these pins must be rated to handle reverse voltages. A reverse voltage on V2 does not disrupt V1 operation and vice-versa.

Freshness Seal Mode

Freshness seal mode prevents V2 battery discharge by keeping V2 disconnected from OUT even if V1 is absent or invalid. Very little current is drawn from V2—typically just 120nA. The following sequence (refer to Figure 10) puts the LTC4420 in freshness seal mode:

1. Power up V2 and V2UV.

2. Once V2OK is asserted high, drive it below 50mV.
3. Power up V1 and ADJ for at least 94ms. Complete steps 2 and 3 within 80s of V2OK asserting high. Freshness seal is enabled.

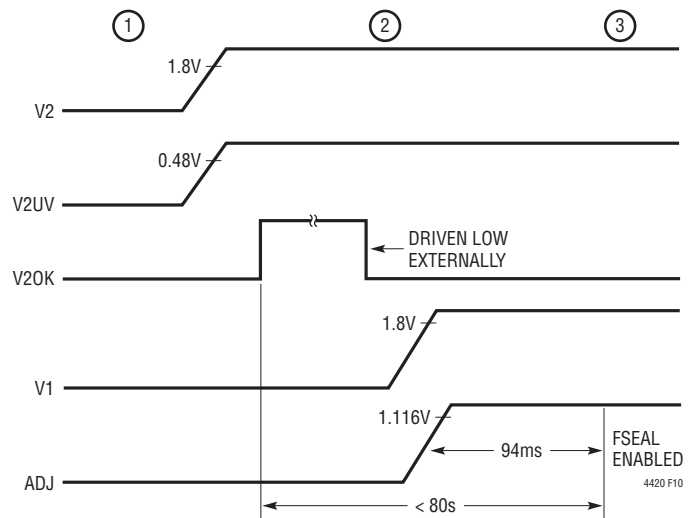

Figure 10. Freshness Seal Engage Procedure

Engage this mode if V2 is a backup battery either during storage or during shipment. Once freshness seal has been engaged, if V1 is disconnected, V2 stays disconnected from OUT. Freshness seal is automatically disabled the next time V1 is revalidated. Limit V2OK pin capacitance to less than 10nF in order to prevent freshness seal mode from accidentally being engaged.

Design Example

In Figure 11, the LTC4420 prioritizes between a 5V supply connected to V1 and a 7.4V 2-cell Li-Ion battery connected to V2. The system is designed to switch OUT to V2 when V1 drops below 4V, provide early power failure warning when V1 drops below 4.5V and disconnect the backup battery voltage when it drops below 6V. Maximum anticipated load current is 100mA and maximum allowed output droop is 100mV. Output rising slew rate is limited to $<0.1\text{V}/\mu\text{s}$ and V1 and V2 input capacitances are limited to 10µF to avoid large inrush current. 1% tolerance resistors are used ADJ, CMP1 and V2UV pin leakages and GND_{SW} V_{OL} are ignored as their design impact is small.

APPLICATIONS INFORMATION

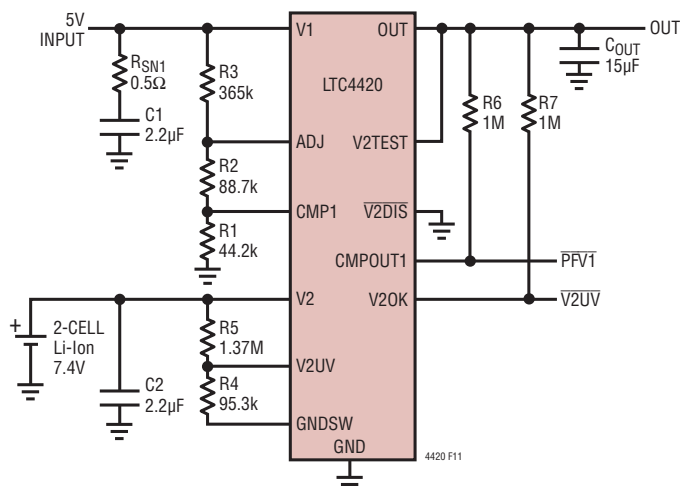

Figure 11. Design Example

First choose total resistive divider current to be $\sim 10\mu\text{A}$ for V1 and $5\mu\text{A}$ for V2. Since the V2 divider is pulsed with a maximum duty cycle of 0.1%, average V2 divider current is negligible. For the 5V supply, this results in:

$$R1 + R2 + R3 = \frac{5\text{V}}{10\mu\text{A}} = 500\text{k}\Omega \quad (14)$$

Since desired switchover threshold, V_{SW1} , and total divider impedance are known, use equation 1 to first calculate R3. Using R3 and equation 2, calculate R1 and R2. Rewriting equation 1 results in:

$$(R1 + R2) = \frac{V_{\text{THA}} \cdot (R1 + R2 + R3)}{V_{\text{SW1}}} \quad (15)$$

Using $(R1 + R2 + R3) = 500\text{k}\Omega$ from equation 14, results in:

$$(R1 + R2) = \frac{1.047\text{V} \cdot 500\text{k}\Omega}{4\text{V}} = 130.9\text{k}\Omega \quad (16)$$

$$R3 \sim (500\text{k}\Omega - 130.9\text{k}\Omega) = 369.1\text{k}\Omega \quad (17)$$

Using the nearest 1% resistor value yields $R3 = 365\text{k}\Omega$.

Rearranging equation 2, results in:

$$R1 = \frac{V_{\text{THC}} \cdot (R1 + R2 + R3)}{V_{\text{PFV1}}} \quad (18)$$

$$R1 = \frac{0.387\text{V}}{4.5\text{V}} \cdot (500\text{k}\Omega) \quad (19)$$

Solving equations 16 and 19 results in $R1 = 43.3\text{k}\Omega$ and $R2 = 87.6\text{k}\Omega$. Using the nearest 1% resistors results in $R2 = 88.7\text{k}\Omega$. Recalculating equation 1 using calculated R2 and R3 values and using standard 1% resistor values close to $43.3\text{k}\Omega$ for R1 results in $R1 = 44.2\text{k}\Omega$.

A similar procedure is used to calculate R4 and R5 using equation 3 and total divider current. Resistance of the GND SW pull-down, typically 120Ω , is neglected as it is small compared to R4 and R5. The design equations are shown below.

$$R4 + R5 = \frac{7.4\text{V}}{5\mu\text{A}} = 1.48\text{M}\Omega \quad (20)$$

as desired current in the divider is $5\mu\text{A}$.

Rewriting equation 3 neglecting pin leakage and assuming $R5 \gg R4$ results in:

$$R4 = \frac{V_{\text{THC}} \cdot (R4 + R5)}{V_{\text{V2UV}}} \quad (21)$$

$$R4 = \frac{0.387\text{V} \cdot 1.48\text{M}\Omega}{6\text{V}} \quad (22)$$

Solving equations 20 and 22 results in $R4 = 96.2\text{k}\Omega$ and $R5 = 1.38\text{M}\Omega$. Choosing the nearest 1% resistor results in $R4 = 95.3\text{k}\Omega$ and $R5 = 1.37\text{M}\Omega$.

C_{OUT} affects both OUT droop during switchover as determined by equation 4 and OUT rising slew rate as determined by equation 9. Calculate minimum C_{OUT} required to meet desired output droop and slew rate specifications using equations 8 and 9 and size C_{OUT} to be the larger of the two values.

APPLICATIONS INFORMATION

C_{OUT} required to limit OUT droop to $< 100\text{mV}$ is given by equation 8,

$$C_{OUT} \geq \frac{(t_{PDA} + t_{SWITCH}) \cdot I_{LOAD}}{100\text{mV}} \quad (23)$$

$$C_{OUT} \geq \frac{(7.3\mu\text{s} + 2.5\mu\text{s}) \cdot 0.1\text{A}}{100\text{mV}} = 9.8\mu\text{F} \quad (24)$$

C_{OUT} required to limit OUT slew rate to $< 0.1\text{V}/\mu\text{s}$ is given by equation 9,

$$C_{OUT} \geq \frac{I_{LIM}}{0.1\text{V}/\mu\text{s}} = 11\mu\text{F} \quad (25)$$

Choose a C_{OUT} capacitor whose minimum value is $11\mu\text{F}$ accounting for voltage and temperature coefficients. Do this for other capacitors as well. Assuming correct PCB

layout, choose C1 to be $2.2\mu\text{F}$, which is $\sim 1/5$ th of C_{OUT} to suppress inductive transients. Also snub C1 with a 0.5Ω resistor to prevent ringing.

Layout Consideration

Make power and ground traces as wide as possible. Place bypass capacitors, snubbers and TVS devices as close to the pin as possible to reduce power path resistance and parasitic inductance. These result in smaller overvoltage transients and improved overvoltage protection. Place resistive dividers close to the pins to improve noise immunity. Use a 4-layer board if possible with layer 2 as dedicated GND and solder the exposed pad to a large PCB GND trace for better heat dissipation. A partial layout for a 2-layer PCB is shown in Figure 12.

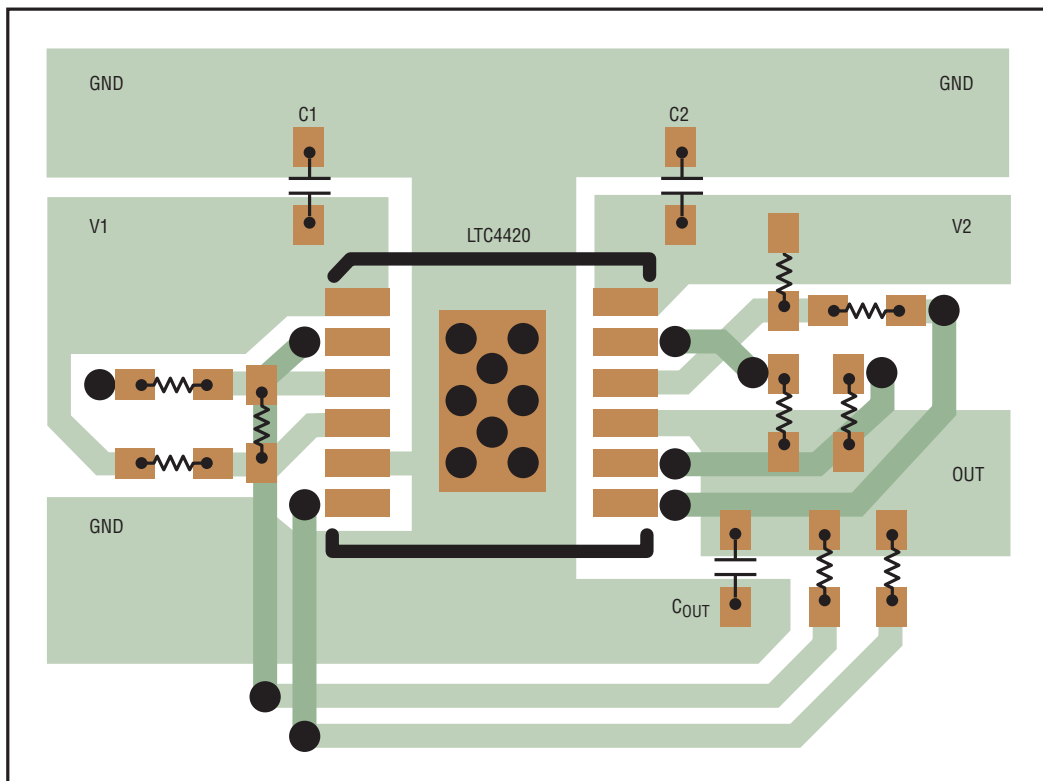

Figure 12. Recommended 12-Lead MSE Layout for a 2-Layer PCB

4419 F12

APPLICATIONS INFORMATION

THERMAL PROTECTION AND MAXIMUM C_{OUT}

Depending on the difference between input and output voltages, the LTC4420's internal power dissipation can be high when operating in current limit mode. This usually occurs when a large C_{OUT} is being charged either during initial power up or when OUT switches over to a higher supply. The situation is worsened if there is a DC load on OUT, as this reduces the current available to charge C_{OUT}. In such cases, self heating can cause power path turn-off due to activation of the thermal protection circuitry. The power path is reactivated when die temperature drops to a safe value. This process can repeat indefinitely if C_{OUT} is discharged fully by load current I_{OUT} in the interval when the power path is off.

Maximum allowed C_{OUT} to prevent activation of the thermal protection circuit depends on several factors such as input supply and output voltages, starting ambient temperature, heat dissipation in the PCB and DC output current. Choose

C_{OUT} < 500µF if possible. If a larger C_{OUT} is necessary, use Figure 13 to choose C_{OUT}. Also follow PCB layout guidelines to improve heat dissipation.

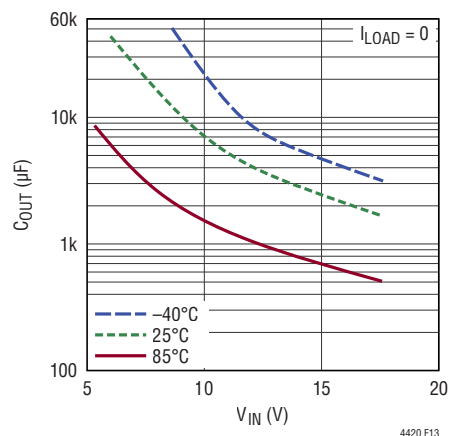
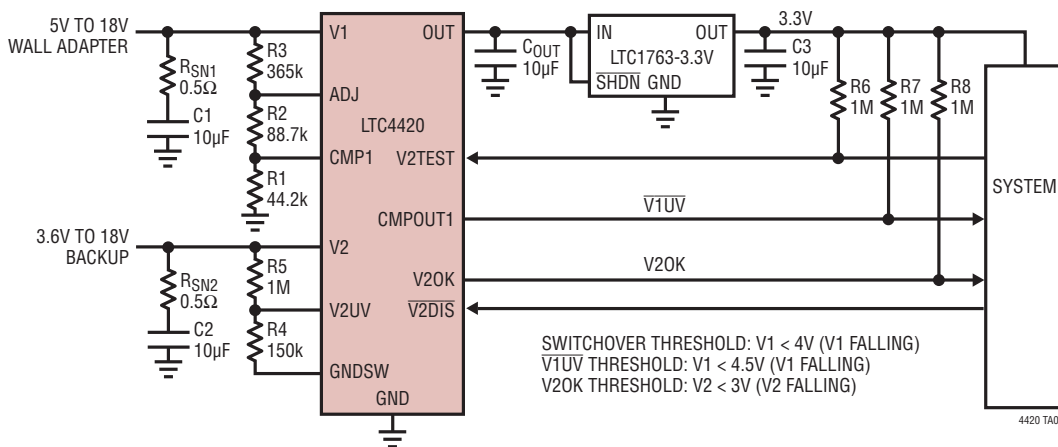

Figure 13. Maximum Allowed C_{OUT} vs Input Voltage for Different T_A

TYPICAL APPLICATIONS

Battery Backup with Interface to Low Voltage Logic



TYPICAL APPLICATIONS

SuperCap Backup with SuperCap Charging

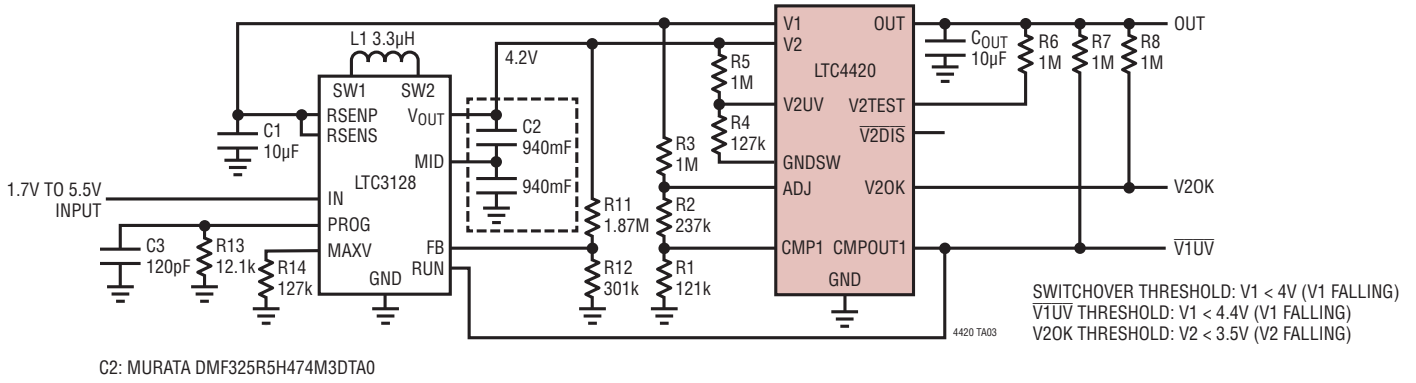

Triple Voltage Monitor

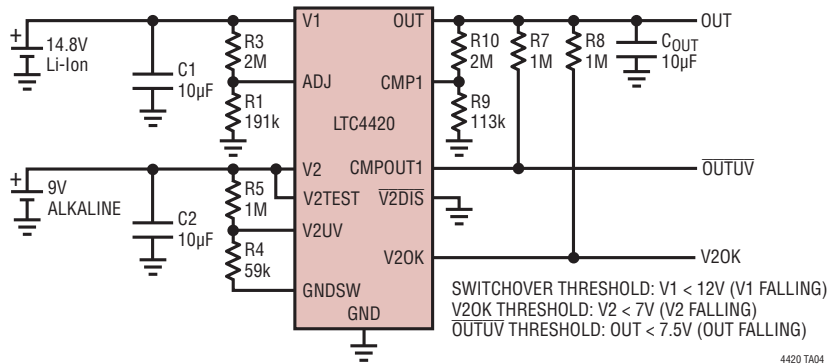

TYPICAL APPLICATIONS

Early Power Failure Warning with Low Battery Indication

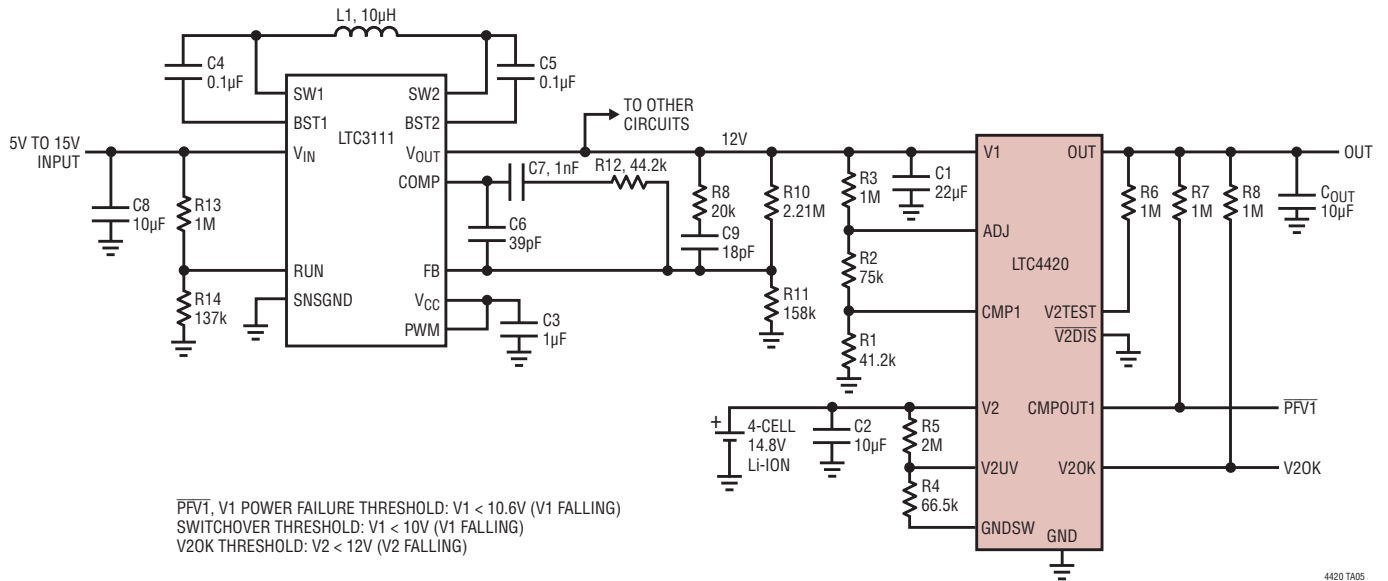

4420 TA05

TYPICAL APPLICATIONS

Prioritization with Failsafe Backup Supply

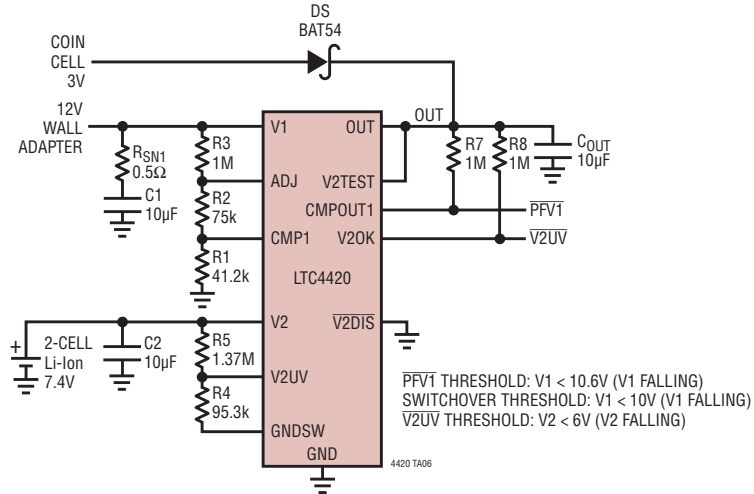

PACKAGE DESCRIPTION

Please refer to <http://www.linear.com/product/LTC4420#packaging> for the most recent package drawings.

DD Package 12-Lead Plastic DFN (3mm × 3mm) (Reference LTC DWG # 05-08-1725 Rev A)

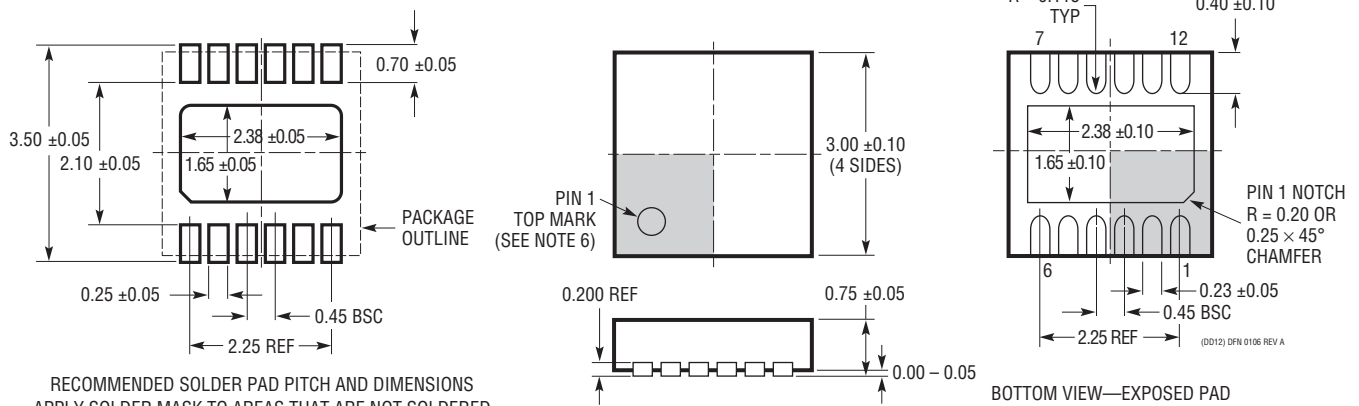

PACKAGE DESCRIPTION

Please refer to <http://www.linear.com/product/LTC4420#packaging> for the most recent package drawings.

MSE Package 12-Lead Plastic MSOP, Exposed Die Pad (Reference LTC DWG # 05-08-1666 Rev G)

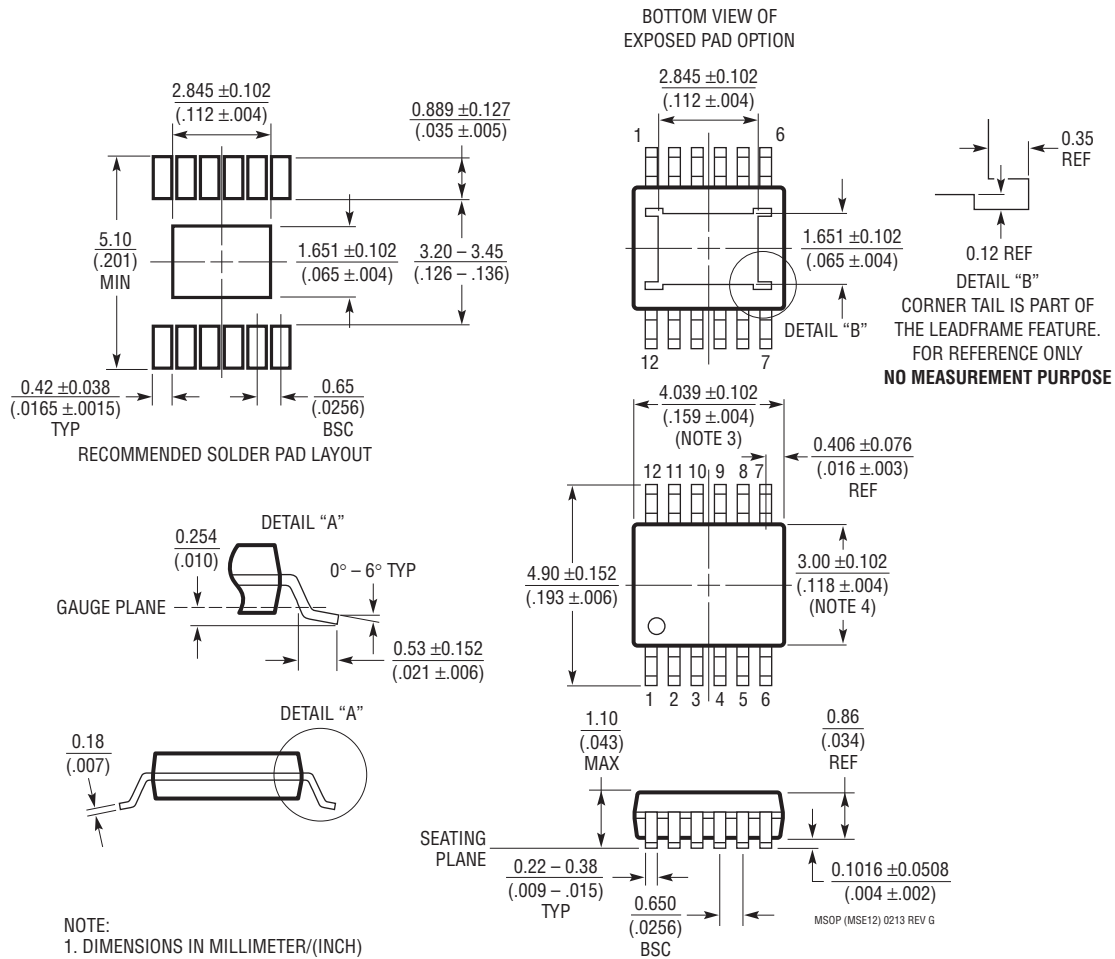

- NOTE:
1. DIMENSIONS IN MILLIMETER/(INCH)
 2. DRAWING NOT TO SCALE
 3. DIMENSION DOES NOT INCLUDE MOLD FLASH, PROTRUSIONS OR GATE BURRS. MOLD FLASH, PROTRUSIONS OR GATE BURRS SHALL NOT EXCEED 0.152mm (.006") PER SIDE
 4. DIMENSION DOES NOT INCLUDE INTERLEAD FLASH OR PROTRUSIONS. INTERLEAD FLASH OR PROTRUSIONS SHALL NOT EXCEED 0.152mm (.006") PER SIDE
 5. LEAD COPLANARITY (BOTTOM OF LEADS AFTER FORMING) SHALL BE 0.102mm (.004") MAX
 6. EXPOSED PAD DIMENSION DOES INCLUDE MOLD FLASH. MOLD FLASH ON E-PAD SHALL NOT EXCEED 0.254mm (.010") PER SIDE.

REVISION HISTORY

REV	DATE	DESCRIPTION	PAGE NUMBER
A	09/17	Updated t_{SWITCH} test condition Updated pin function for Exposed Pad	3 6

Looking for pricing, stock, or lifecycle information?

Click below to explore more details on WIN SOURCE:

 [View LTC4420CMSE#PBF on WIN SOURCE](#)

 [Linear Technology](#) Information

Optimize Your Supply Chain with WIN SOURCE Solutions

-  Global Sourcing Solution
-  Obsolete Management
-  Cost Control Management
-  Shortage Management
-  Alternative Solution
-  Excess Inventory Management