



**THE DATASHEET OF
LTC7813EUH#PBF**



FEATURES

- Synchronous Boost and Buck Controllers
- When Cascaded, Allows V_{IN} Above, Below, or Equal to Regulated V_{OUT} of Up to 60V
- Wide Bias Input Voltage Range: 4.5V to 60V
- Output Remains in Regulation Through Input Dips (e.g. Cold Crank) Down to 2.2V
- Adjustable Gate Drive Level 5V to 10V (OPTI-DRIVE)
- Low EMI with Low Input and Output Ripple
- Fast Output Transient Response
- No External Bootstrap Diodes Required
- High Light Load Efficiency
- Low Operating I_Q : 29 μ A (One Channel On)
- Low Operating I_Q : 34 μ A (Both Channels On)
- R_{SENSE} or Lossless DCR Current Sensing
- Buck Output Voltage Range: $0.8V \leq V_{OUT} \leq 60V$
- Boost Output Voltage Up to 60V
- Phase-Lockable Frequency (75kHz to 850kHz)
- Small 32-Pin 5mm \times 5mm QFN Package

APPLICATIONS

- Automotive and Industrial Power Systems
- High Power Battery Operated Systems

DESCRIPTION

The **LTC[®]7813** is a high performance synchronous Boost+Buck DC/DC switching regulator controller that drives all N-channel power MOSFET stages. It contains independent step-up (boost) and step-down (buck) controllers that can regulate two separate outputs or be cascaded to regulate an output voltage from an input voltage that can be above, below, or equal to the output voltage. The LTC7813 operates from a wide 4.5V to 60V input supply range. When biased from the output of the boost regulator, the LTC7813 can operate from an input supply as low as 2.2V after start-up. The 34 μ A no-load quiescent current (both channels on) extends operating runtime in battery-powered systems.

Unlike conventional buck-boost regulators, the LTC7813's cascaded Boost+Buck solution has continuous, non-pulsating, input and output currents, substantially reducing voltage ripple and EMI. The LTC7813 has independent feedback and compensation points for the boost and buck regulation loops, enabling a fast output transient response that can be externally optimized.

LT, LT, LTC, LTM, Linear Technology, the Linear logo and Burst Mode are registered trademarks of Linear Technology Corporation. All other trademarks are the property of their respective owners.

TYPICAL APPLICATION

Wide Input Range to 10V/10A Low I_Q Cascaded Boost+Buck Regulator

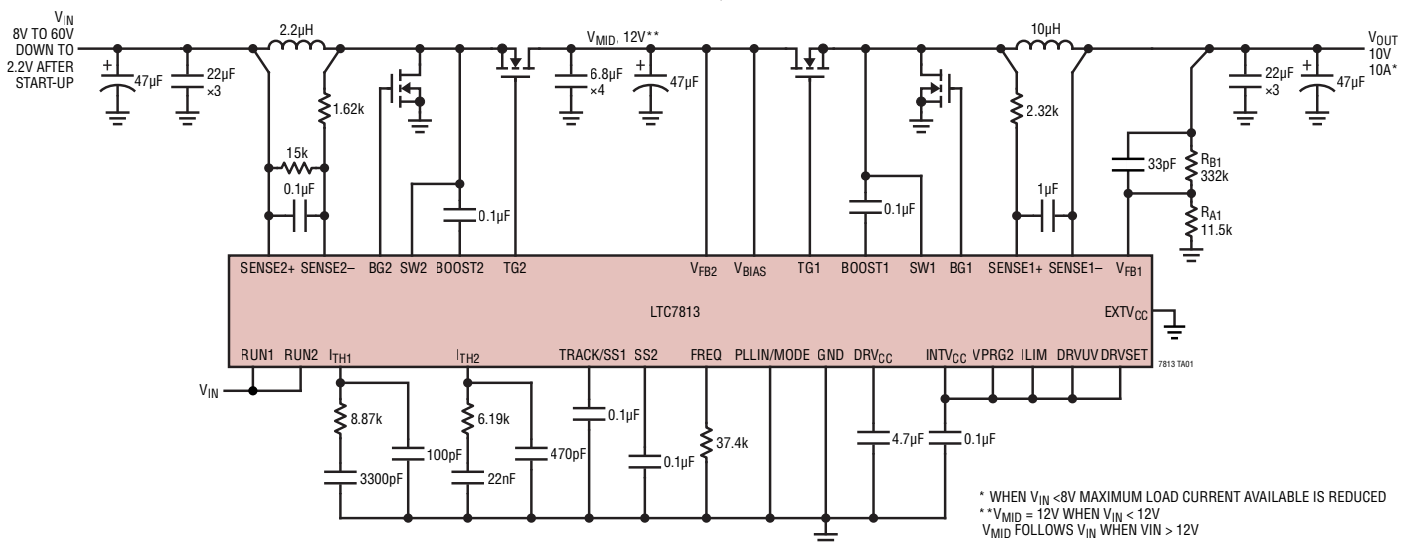

LTC7813

ABSOLUTE MAXIMUM RATINGS

(Note 1)

Bias Input Supply Voltage (V_{BIAS}).....	-0.3V to 65V
Topside Driver Voltages	
BOOST1, BOOST2.....	-0.3V to 76V
Switch Voltage (SW1, SW2).....	-5V to 70V
DRV_{CC} , (BOOST1-SW1), (BOOST2-SW2)....	-0.3V to 11V
BG1, BG2, TG1, TG2.....	(Note 8)
RUN1, RUN2 Voltages.....	-0.3V to 65V
SENSE1 ⁺ , SENSE2 ⁺ , SENSE1 ⁻	
SENSE2 ⁻ Voltages.....	-0.3V to 65V
PLLIN/MODE, FREQ, DRVSET Voltages.....	-0.3V to 6V
EXTV _{CC} Voltage.....	-0.3V to 14V
ITH1, ITH2, V_{FB1} Voltages.....	-0.3V to 6V
V_{FB2} Voltage.....	-0.3V to 65V
VPRG2 Voltage.....	-0.3V to 6V
TRACK/SS1, SS2 Voltages.....	-0.3V to 6V
Operating Junction Temperature Range (Notes 2, 3)	
LTC7813E, LTC7813I.....	-40°C to 125°C
LTC7813H.....	-40°C to 150°C
LTC7813MP.....	-55°C to 150°C
Storage Temperature Range.....	-65°C to 150°C

PIN CONFIGURATION

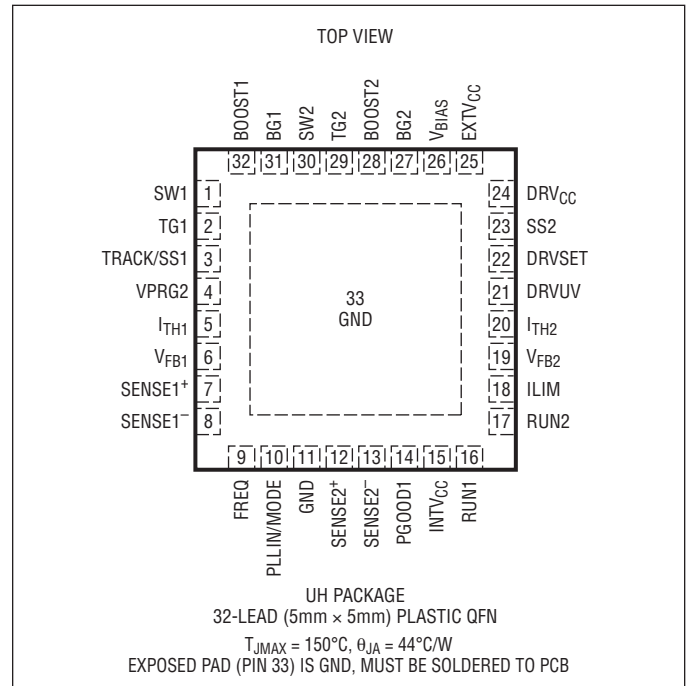

ORDER INFORMATION

LEAD FREE FINISH	TAPE AND REEL	PART MARKING*	PACKAGE DESCRIPTION	TEMPERATURE RANGE
LTC7813EUH#PBF	LTC7813EUH#TRPBF	7813	32-Lead (5mm × 5mm) Plastic QFN	-40°C to 125°C
LTC7813IUH#PBF	LTC7813IUH#TRPBF	7813	32-Lead (5mm × 5mm) Plastic QFN	-40°C to 125°C
LTC7813HUH#PBF	LTC7813HUH#TRPBF	7813	32-Lead (5mm × 5mm) Plastic QFN	-40°C to 150°C
LTC7813MPUH#PBF	LTC7813MPUH#TRPBF	7813	32-Lead (5mm × 5mm) Plastic QFN	-55°C to 150°C

Consult LTC Marketing for parts specified with wider operating temperature ranges. *The temperature grade is identified by a label on the shipping container.

For more information on lead free part marking, go to: <http://www.linear.com/leadfree/>

For more information on tape and reel specifications, go to: <http://www.linear.com/tapeandreeel/>

ELECTRICAL CHARACTERISTICS The ● denotes the specifications which apply over the specified operating junction temperature range, otherwise specifications are at $T_A = 25^\circ\text{C}$. (Note 2) $V_{\text{BIAS}} = 12\text{V}$, $V_{\text{RUN1,2}} = 5\text{V}$, $V_{\text{EXTVCC}} = 0\text{V}$, $V_{\text{DRVSET}} = 0\text{V}$, $V_{\text{PRG2}} = 0\text{V}$ unless otherwise noted.

SYMBOL	PARAMETER	CONDITIONS	MIN	TYP	MAX	UNITS	
V_{BIAS}	Bias Input Supply Operating Voltage Range		4.5		60	V	
V_{OUT1}	Buck Regulated Output Voltage Set Point		0.8		60	V	
V_{OUT2}	Boost Regulated Output Voltage Set Point				60	V	
$V_{\text{SENSE2(CM)}}$	SENSE2 Pins Common Mode Range (BOOST Converter Input Supply Voltage)		2.2		60	V	
V_{FB1}	Buck Regulated Feedback Voltage	(Note 4) ITH1 Voltage = 1.2V 0°C to 85°C	● 0.792 ● 0.788	0.800 0.800	0.808 0.812	V V	
V_{FB2}	Boost Regulated Feedback Voltage	(Note 4) ITH2 Voltage = 1.2V VPRG2 = 0V VPRG2 = FLOAT VPRG2 = INTV _{CC}	● 1.182 ● 9.78 ● 11.74	1.200 10.00 12.00	1.218 10.22 12.26	V V V	
I_{FB1}	Buck Feedback Current	(Note 4)		-2	±50	nA	
I_{FB2}	Boost Feedback Current	(Note 4) VPRG2 = 0V VPRG2 = FLOAT VPRG2 = INTV _{CC}		±0.01 4 5	±0.05 6 7	μA μA μA	
	Reference Voltage Line Regulation	(Note 4) $V_{\text{BIAS}} = 4.5\text{V}$ to 60V		0.002	0.02	%/V	
	Output Voltage Load Regulation	(Note 4) Measured in Servo Loop, ΔITH Voltage = 1.2V to 0.7V	●	0.01	0.1	%	
		(Note 4) Measured in Servo Loop, ΔITH Voltage = 1.2V to 2V	●	-0.01	-0.1	%	
$g_{\text{m1,2}}$	Transconductance Amplifier g_{m}	(Note 4) ITH1,2 = 1.2V, Sink/Source 5μA		2		mmho	
I_{Q}	Input DC Supply Current	(Note 5), $V_{\text{DRVSET}} = 0\text{V}$					
	Pulse-Skipping or Forced Continuous Mode (One Channel On)	RUN1 = 5V and RUN2 = 0V or RUN2 = 5V and RUN1 = 0V $V_{\text{FB1}} = 0.83\text{V}$ (No Load), $V_{\text{FB2}} = 1.25\text{V}$ (No Load)		1.6 0.8		mA mA	
	Pulse-Skipping or Forced Continuous Mode (Both Channels On)	RUN1,2 = 5V, $V_{\text{FB1}} = 0.83\text{V}$ (No Load), $V_{\text{FB2}} = 1.25\text{V}$ (No Load)		2.2		mA	
	Sleep Mode (One Channel On, Buck)	RUN1 = 5V and RUN2 = 0V $V_{\text{FB1}} = 0.83\text{V}$ (No Load)	●	29	55	μA	
	Sleep Mode (One Channel On, Boost)	RUN2 = 5V and RUN1 = 0V, $V_{\text{FB2}} = 1.25\text{V}$ (No Load)		29	50	μA	
	Sleep Mode (Both Channels On)	RUN1 = 5V and RUN2 = 5V, $V_{\text{FB1}} = 0.83\text{V}$ (No Load), $V_{\text{FB2}} = 1.25\text{V}$ (No Load)		34	55	μA	
	Shutdown	RUN1,2 = 0V		3.6	10	μA	
UVLO	Undervoltage Lockout	DRV _{CC} Ramping Up DRVUV = 0V DRVUV = INTV _{CC}	● ●	4.0 7.5	4.2 7.8	V V	
		DRV _{CC} Ramping Down DRVUV = 0V DRVUV = INTV _{CC}	● ●	3.6 6.4	3.8 6.7	4.0 7.0	V V
	Buck Feedback Overvoltage Protection	Measured at V_{FB1} Relative to Regulated V_{FB1}		7	10	13	%
	SENSE1+ Pin Current				±1	μA	
	SENSE2+ Pin Current			170		μA	
	SENSE1- Pin Current	$V_{\text{SENSE1-}} < V_{\text{INTVCC}} - 0.5\text{V}$ $V_{\text{SENSE1-}} > V_{\text{INTVCC}} + 0.5\text{V}$		700	±1	μA μA	
	SENSE2- Pin Current	$V_{\text{SENSE2+}}, V_{\text{SENSE2-}} = 12\text{V}$			±1	μA	

ELECTRICAL CHARACTERISTICS

The ● denotes the specifications which apply over the specified operating junction temperature range, otherwise specifications are at $T_A = 25^\circ\text{C}$. (Note 2) $V_{\text{BIAS}} = 12\text{V}$, $V_{\text{RUN1,2}} = 5\text{V}$, $V_{\text{EXTVCC}} = 0\text{V}$, $V_{\text{DRVSET}} = 0\text{V}$, $V_{\text{PRG2}} = 0\text{V}$ unless otherwise noted.

SYMBOL	PARAMETER	CONDITIONS	MIN	TYP	MAX	UNITS
	Maximum Duty Factor for TG	Buck (Channel 1) in Dropout, $\text{FREQ} = 0\text{V}$ Boost (Channel 2)	97.5	99 100		% %
	Maximum Duty Factor for BG	Buck (Channel 1) in Overvoltage Boost (Channel 2)		100 96		% %
$I_{\text{TRACK/SS1}}$	Soft-Start Charge Current	$V_{\text{TRACK/SS1}} = 0\text{V}$	8	10	12	μA
I_{SS2}	Soft-Start Charge Current	$V_{\text{SS2}} = 0\text{V}$	8	10	12	μA
$V_{\text{RUN1,2 ON}}$	RUN Pin On Threshold	V_{RUN1} , V_{RUN2} Rising	● 1.22	1.275	1.33	V
	RUN Pin Hysteresis			75		mV
$V_{\text{SENSE1,2(MAX)}}$	Maximum Current Sense Threshold	$I_{\text{LIM}} = \text{Float}$ $I_{\text{LIM}} = 0\text{V}$ $I_{\text{LIM}} = \text{INTVCC}$	● 65 ● 43 ● 90	75 50 100	85 58 109	mV mV mV

Gate Driver

TG1,2	Pull-Up On-Resistance Pull-Down On-Resistance	$V_{\text{DRVSET}} = \text{INTVCC}$		2.2 1.0		Ω Ω
BG1,2	Pull-Up On-Resistance Pull-Down On-Resistance	$V_{\text{DRVSET}} = \text{INTVCC}$		2.2 1.0		Ω Ω
	BOOST1,2 to DRVCC Switch On-Resistance	$V_{\text{SW1,2}} = 0\text{V}$, $V_{\text{DRVSET}} = \text{INTVCC}$		3.7		Ω
	TG Transition Time: Rise Time Fall Time	(Note 6) $V_{\text{DRVSET}} = \text{INTVCC}$ $C_{\text{LOAD}} = 3300\text{pF}$ $C_{\text{LOAD}} = 3300\text{pF}$		25 15		ns ns
	BG Transition Time: Rise Time Fall Time	(Note 6) $V_{\text{DRVSET}} = \text{INTVCC}$ $C_{\text{LOAD}} = 3300\text{pF}$ $C_{\text{LOAD}} = 3300\text{pF}$		25 15		ns ns
	Top Gate Off to Bottom Gate On Delay Synchronous Switch-On Delay Time	$C_{\text{LOAD}} = 3300\text{pF}$ Each Driver, $V_{\text{DRVSET}} = \text{INTVCC}$ Buck (Channel 1) Boost (Channel 2)		55 85		ns ns
	Bottom Gate Off to Top Gate On Delay Top Switch-On Delay Time	$C_{\text{LOAD}} = 3300\text{pF}$ Each Driver, $V_{\text{DRVSET}} = \text{INTVCC}$ Buck (Channel 1) Boost (Channel 2)		50 80		ns ns
$t_{\text{ON(MIN)1}}$	Buck Minimum On-Time	(Note 7) $V_{\text{DRVSET}} = \text{INTVCC}$		80		ns
$t_{\text{ON(MIN)2}}$	Boost Minimum On-Time	(Note 7) $V_{\text{DRVSET}} = \text{INTVCC}$		120		ns

DRVCC Linear Regulator

	DRVCC Voltage from Internal V_{BIAS} LDO	$V_{\text{EXTVCC}} = 0\text{V}$ $7\text{V} < V_{\text{BIAS}} < 60\text{V}$, $\text{DRVSET} = 0\text{V}$ $11\text{V} < V_{\text{BIAS}} < 60\text{V}$, $\text{DRVSET} = \text{INTVCC}$	5.8 9.6	6.0 10.0	6.2 10.4	V V
	DRVCC Load Regulation from V_{BIAS} LDO	$I_{\text{CC}} = 0\text{mA}$ to 50mA , $V_{\text{EXTVCC}} = 0\text{V}$		0.9	2.0	%
	DRVCC Voltage from Internal EXTVCC LDO	$7\text{V} < V_{\text{EXTVCC}} < 13\text{V}$, $\text{DRVSET} = 0\text{V}$ $11\text{V} < V_{\text{EXTVCC}} < 13\text{V}$, $\text{DRVSET} = \text{INTVCC}$	5.8 9.6	6.0 10.0	6.2 10.4	V V
	DRVCC Load Regulation from Internal EXTVCC LDO	$I_{\text{CC}} = 0\text{mA}$ to 50mA , $V_{\text{EXTVCC}} = 8.5\text{V}$, $V_{\text{DRVSET}} = 0\text{V}$		0.7	2.0	%
	EXTVCC LDO Switchover Voltage	EXTVCC Ramping Positive $\text{DRVSET} = 0\text{V}$ or $R_{\text{DRVSET}} \leq 100\text{k}\Omega$ $\text{DRVSET} = \text{INTVCC}$	4.5 7.4	4.7 7.7	4.9 8.0	V V
	EXTVCC Hysteresis			250		mV
	Programmable DRVCC	$R_{\text{DRVSET}} = 50\text{k}\Omega$, $V_{\text{EXTVCC}} = 0\text{V}$		5.0		V
	Programmable DRVCC	$R_{\text{DRVSET}} = 70\text{k}\Omega$, $V_{\text{EXTVCC}} = 0\text{V}$	6.4	7.0	7.6	V
	Programmable DRVCC	$R_{\text{DRVSET}} = 90\text{k}\Omega$, $V_{\text{EXTVCC}} = 0\text{V}$		9.0		V

ELECTRICAL CHARACTERISTICS

The ● denotes the specifications which apply over the specified operating junction temperature range, otherwise specifications are at $T_A = 25^\circ\text{C}$. (Note 2) $V_{\text{BIAS}} = 12\text{V}$, $V_{\text{RUN1,2}} = 5\text{V}$, $V_{\text{EXTVCC}} = 0\text{V}$, $V_{\text{DRVSET}} = 0\text{V}$, $V_{\text{PRG2}} = 0\text{V}$ unless otherwise noted.

SYMBOL	PARAMETER	CONDITIONS	MIN	TYP	MAX	UNITS
Oscillator and Phase-Locked Loop						
	Programmable Frequency	$R_{\text{FREQ}} = 25\text{k}\Omega$, PLLIN/MODE = DC Voltage		105		kHz
	Programmable Frequency	$R_{\text{FREQ}} = 65\text{k}\Omega$, PLLIN/MODE = DC Voltage	375	440	505	kHz
	Programmable Frequency	$R_{\text{FREQ}} = 105\text{k}\Omega$, PLLIN/MODE = DC Voltage		835		kHz
	Low Fixed Frequency	$V_{\text{FREQ}} = 0\text{V}$, PLLIN/MODE = DC Voltage	320	350	380	kHz
	High Fixed Frequency	$V_{\text{FREQ}} = \text{INTV}_{\text{CC}}$, PLLIN/MODE = DC Voltage	485	535	585	kHz
	Synchronizable Frequency	PLLIN/MODE = External Clock	●	75	850	kHz
PLLIN V_{IH}	PLLIN/MODE Input High Level	PLLIN/MODE = External Clock	●	2.5		V
PLLIN V_{IL}	PLLIN/MODE Input Low Level	PLLIN/MODE = External Clock	●		0.5	V
BOOST2 Charge Pump						
	BOOST2 Charge Pump Available Output Current	FREQ = 0V, PLLIN/MODE = INTV_{CC} $V_{\text{BOOST2}} = 16.5\text{V}$, $V_{\text{SW2}} = 12\text{V}$ $V_{\text{BOOST2}} = 19\text{V}$, $V_{\text{SW2}} = 12\text{V}$		75		μA
				35		μA

Note 1: Stresses beyond those listed under Absolute Maximum Ratings may cause permanent damage to the device. Exposure to any Absolute Maximum Ratings for extended periods may affect device reliability and lifetime.

Note 2: The LTC7813 is tested under pulsed load conditions such that $T_J \approx T_A$. The LTC7813E is guaranteed to meet performance specifications from 0°C to 85°C . Specifications over the -40°C to 125°C operating junction temperature range are assured by design, characterization and correlation with statistical process controls. The LTC7813I is guaranteed over the -40°C to 125°C operating junction temperature range, the LTC7813H is guaranteed over the -40°C to 150°C operating junction temperature range and the LTC7813MP is tested and guaranteed over the -55°C to 150°C operating junction temperature range. High junction temperatures degrade operating lifetimes; operating lifetime is derated for junction temperatures greater than 125°C . Note that the maximum ambient temperature consistent with these specifications is determined by specific operating conditions in conjunction with board layout, the rated package thermal impedance and other environmental factors. The junction temperature (T_J , in $^\circ\text{C}$) is calculated from the ambient temperature (T_A , in $^\circ\text{C}$) and power dissipation (P_D , in Watts) according to the formula:

$$T_J = T_A + (P_D \cdot \theta_{JA})$$

where $\theta_{JA} = 44^\circ\text{C}$.

Note 3: This IC includes overtemperature protection that is intended to protect the device during momentary overload conditions. The maximum rated junction temperature will be exceeded when this protection is active. Continuous operation above the specified absolute maximum operating junction temperature may impair device reliability or permanently damage the device.

Note 4: The LTC7813 is tested in a feedback loop that servos $V_{\text{ITH1,2}}$ to a specified voltage and measures the resultant $V_{\text{FB1,2}}$. The specification at 85°C is not tested in production and is assured by design, characterization and correlation to production testing at other temperatures (125°C for the LTC7813E and LTC7813I, 150°C for the LTC7813H and LTC7813MP). For the LTC7813I and LTC7813H, the specification at 0°C is not tested in production and is assured by design, characterization and correlation to production testing at -40°C . For the LTC7813MP, the specification at 0°C is not tested in production and is assured by design, characterization and correlation to production testing at -55°C .

Note 5: Dynamic supply current is higher due to the gate charge being delivered at the switching frequency. See Applications information.

Note 6: Rise and fall times are measured using 10% and 90% levels. Delay times are measured using 50% levels

Note 7: The minimum on-time condition is specified for an inductor peak-to-peak ripple current $>40\%$ of I_{MAX} (See Minimum On-Time Considerations in the Applications Information section).

Note 8: Do not apply a voltage or current source to these pins. They must be connected to capacitive loads only, otherwise permanent damage may occur.

TYPICAL PERFORMANCE CHARACTERISTICS

**Efficiency vs Load Current,
 $V_{IN} = 18V$**

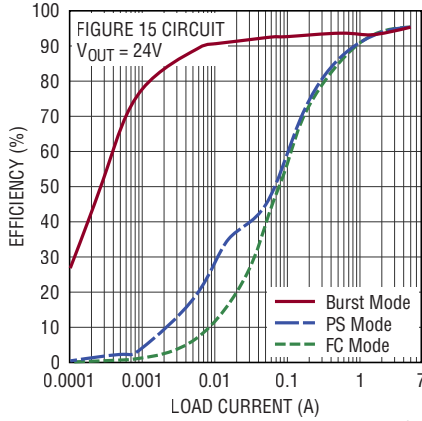

PS = PULSE-SKIPPING
FC = FORCED CONTINUOUS

**Efficiency vs Load Current,
 $V_{IN} = 24V$**

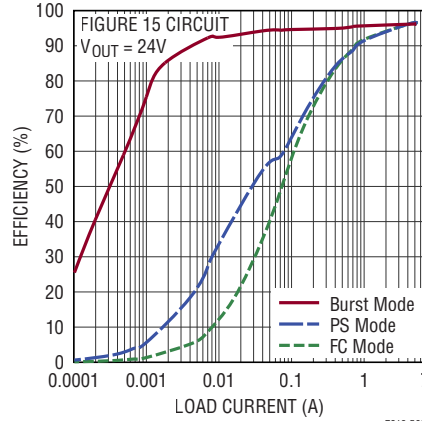

**Efficiency vs Load Current,
 $V_{IN} = 36V$**

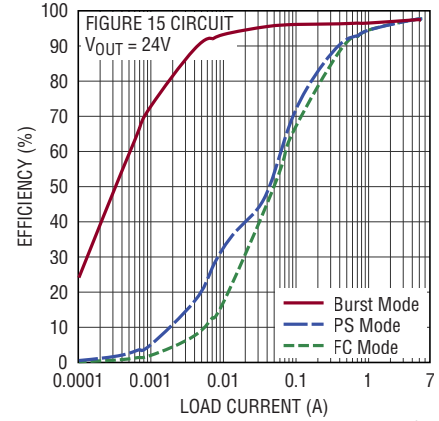

**Power Loss vs Load Current,
 $V_{IN} = 18V$**

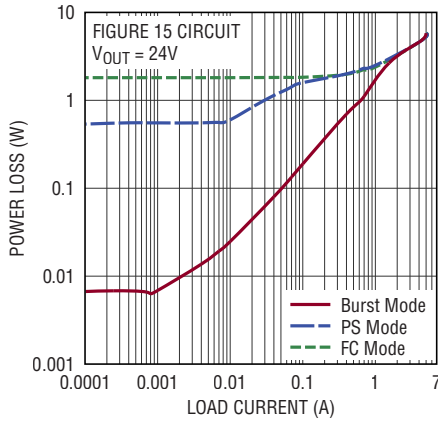

**Power Loss vs Load Current,
 $V_{IN} = 24V$**

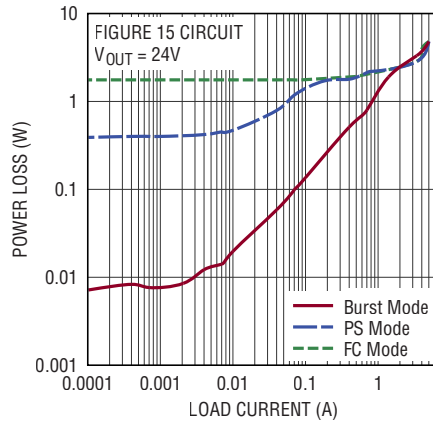

**Power Loss vs Load Current,
 $V_{IN} = 36V$**

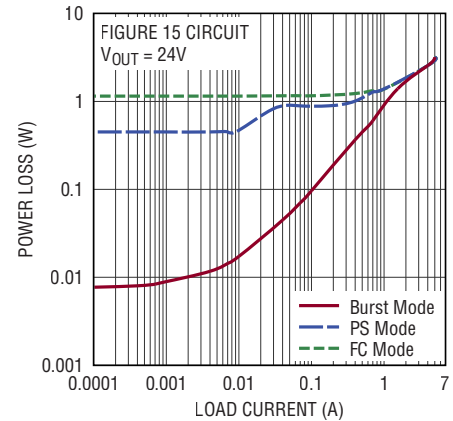

Efficiency vs Input Voltage

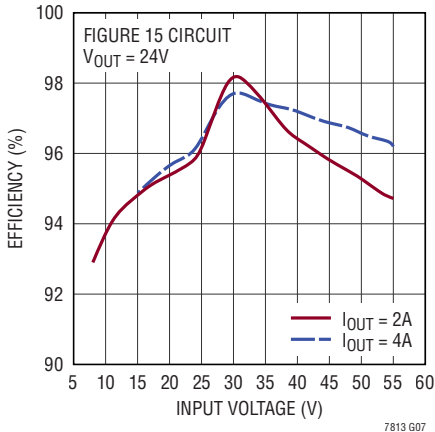

**Buck Regulated Feedback Voltage
vs Temperature**

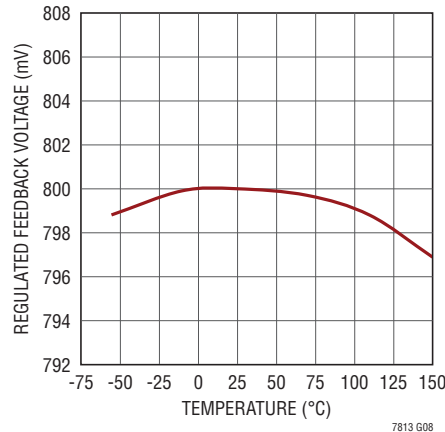

**Boost Regulated Feedback
Voltage vs Temperature**

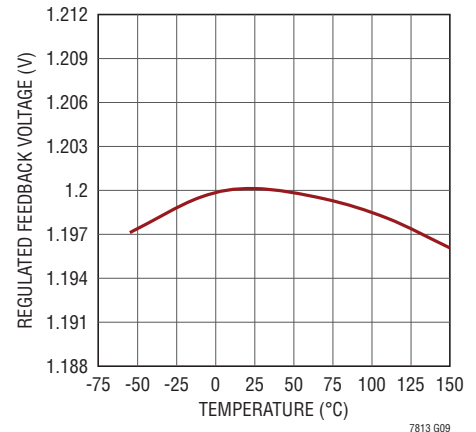

TYPICAL PERFORMANCE CHARACTERISTICS

**Load Step at $V_{IN} = 18V$,
Burst Mode Operation**

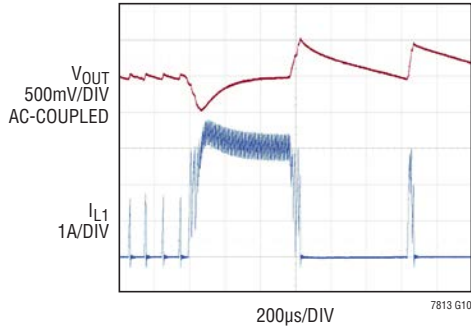

FIGURE 15 CIRCUIT
 $V_{OUT} = 24V$

**Load Step at $V_{IN} = 24V$,
Burst Mode Operation**

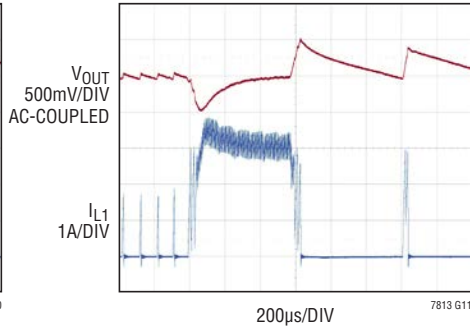

FIGURE 15 CIRCUIT
 $V_{OUT} = 24V$

**Load Step at $V_{IN} = 36V$,
Burst Mode Operation**

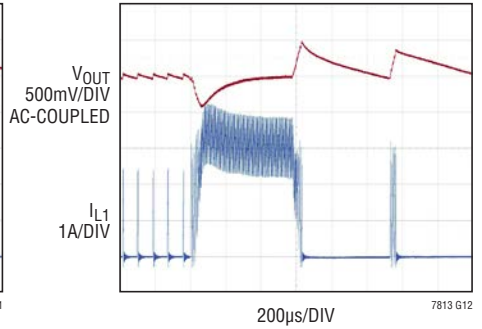

FIGURE 15 CIRCUIT
 $V_{OUT} = 24V$

**Load Step at $V_{IN} = 18V$,
Pulse-Skipping Mode**

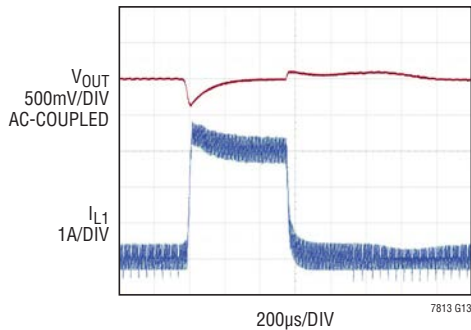

FIGURE 15 CIRCUIT
 $V_{OUT} = 24V$

**Load Step at $V_{IN} = 24V$,
Pulse-Skipping Mode**

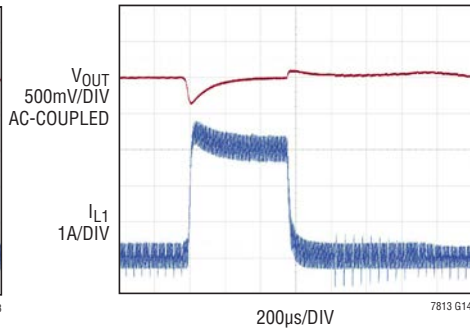

FIGURE 15 CIRCUIT
 $V_{OUT} = 24V$

**Load Step at $V_{IN} = 36V$,
Pulse-Skipping Mode**

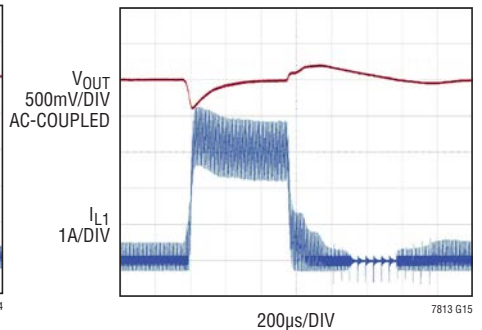

FIGURE 15 CIRCUIT
 $V_{OUT} = 24V$

**Load Step at $V_{IN} = 18V$,
Forced Continuous Mode**

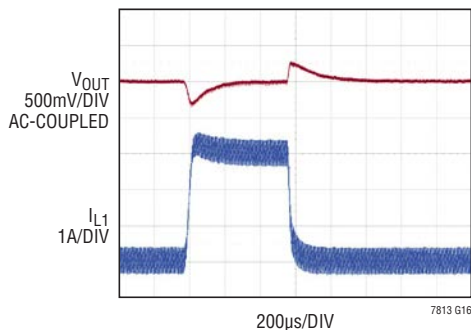

FIGURE 15 CIRCUIT
 $V_{OUT} = 24V$

**Load Step at $V_{IN} = 24V$,
Forced Continuous Mode**

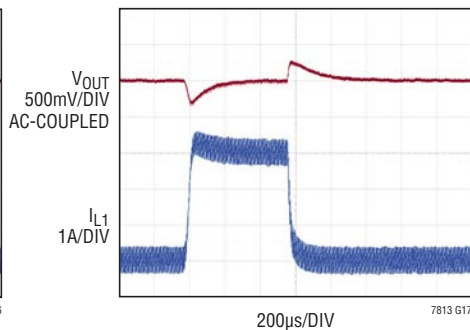

FIGURE 15 CIRCUIT
 $V_{OUT} = 24V$

**Load Step at $V_{IN} = 36V$,
Forced Continuous Mode**

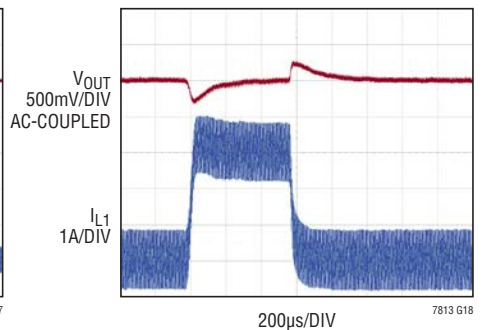
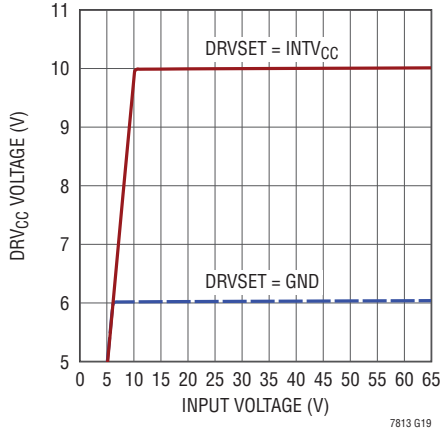

FIGURE 15 CIRCUIT
 $V_{OUT} = 24V$

TYPICAL PERFORMANCE CHARACTERISTICS

DRV_{CC} Line Regulation



DRV_{CC} and EXTV_{CC} vs Load Current

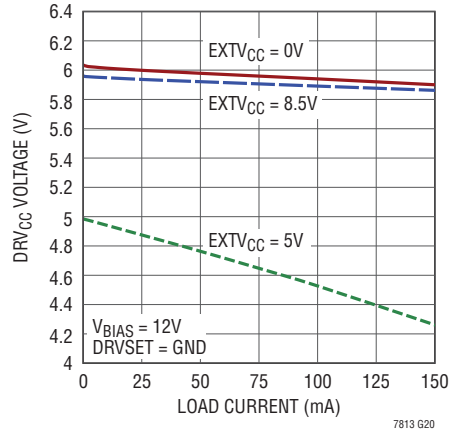

EXTV_{CC} Switchover and DRV_{CC} Voltages vs Temperature

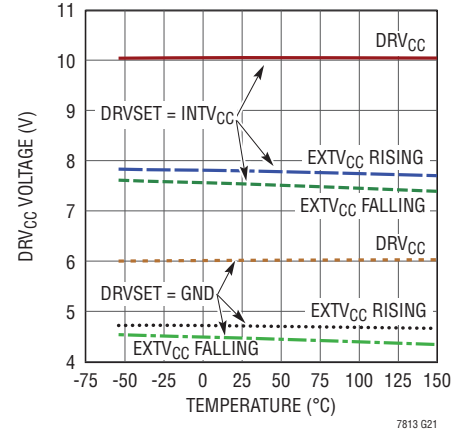

SENSE Pins Input Current vs V_{SENSE} Voltage

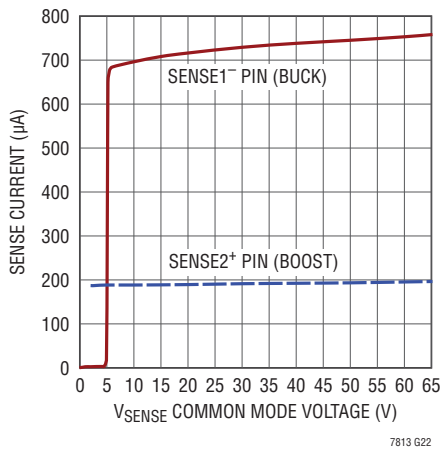

Buck SENSE1⁻ Pin Input Bias Current vs Temperature

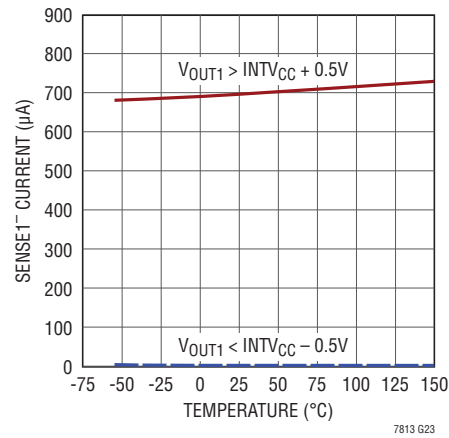

Boost SENSE2⁺ Pins Input Current vs Temperature

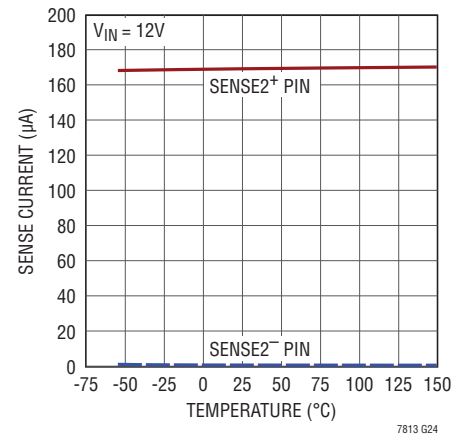

Maximum Current Sense Threshold vs Duty Cycle

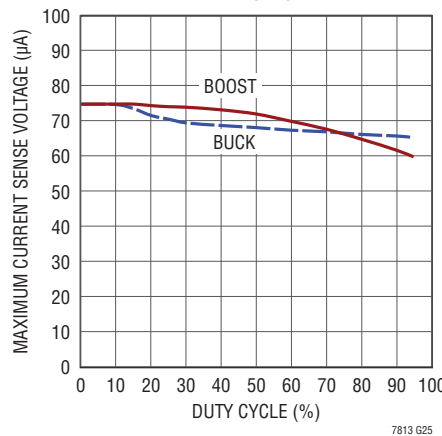

Maximum Current Sense Threshold vs I_{TH} Voltage

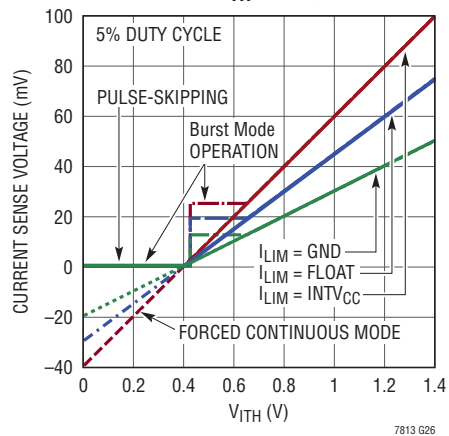

TRACK/SS1 and SS2 Pull-Up Current vs Temperature

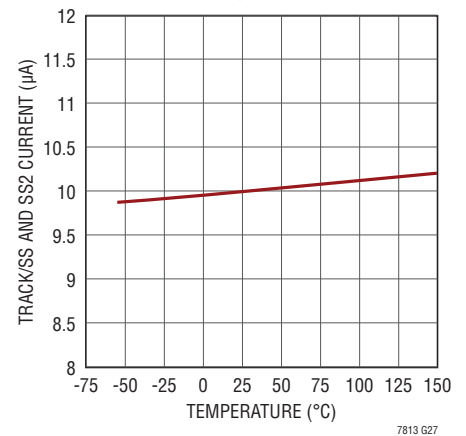

TYPICAL PERFORMANCE CHARACTERISTICS

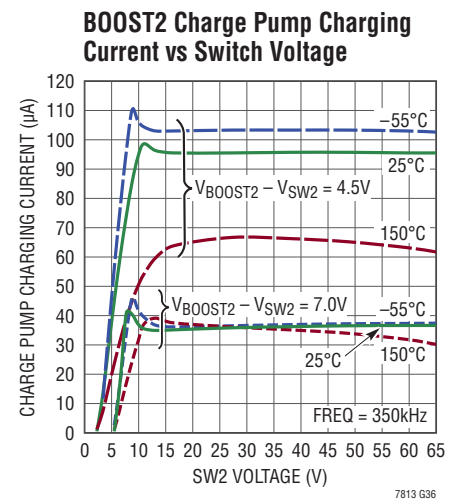
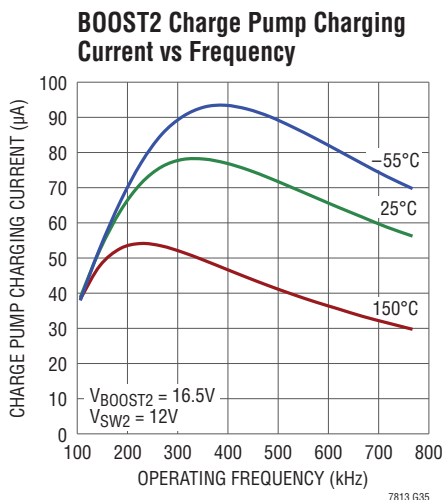
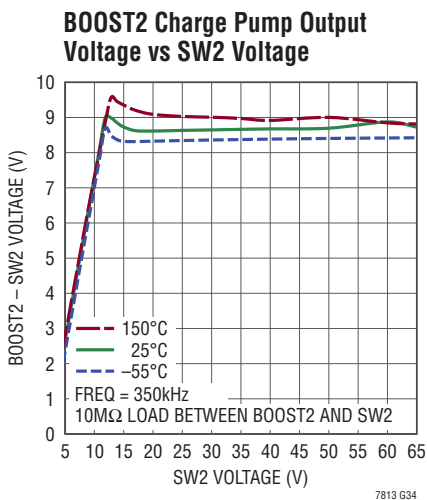
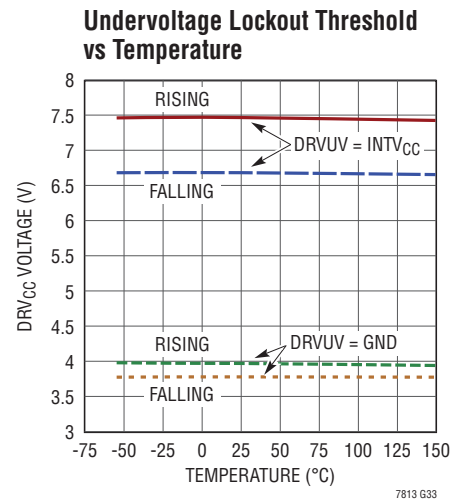
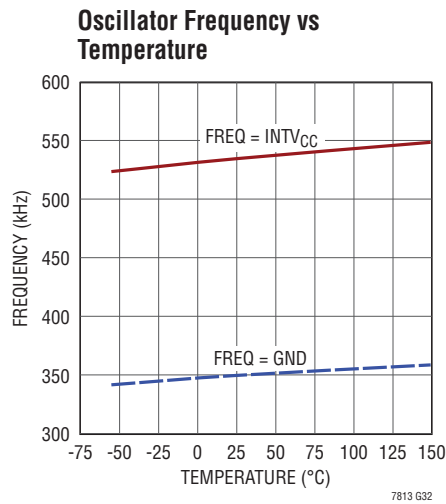
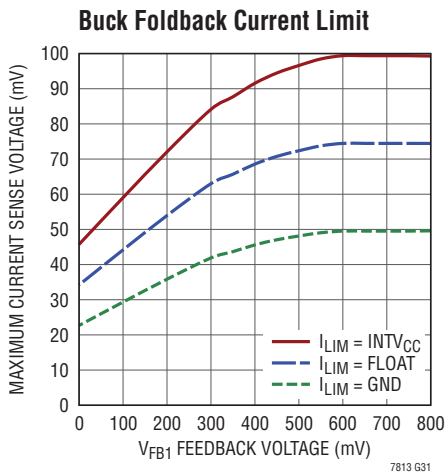
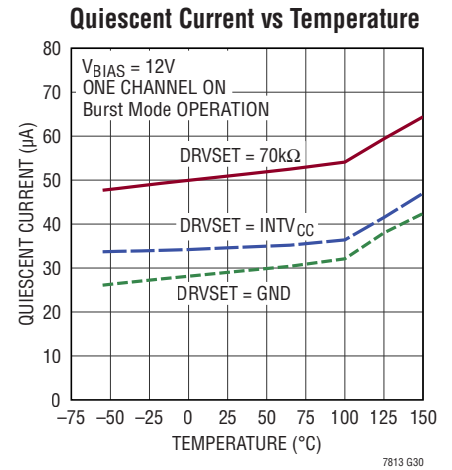
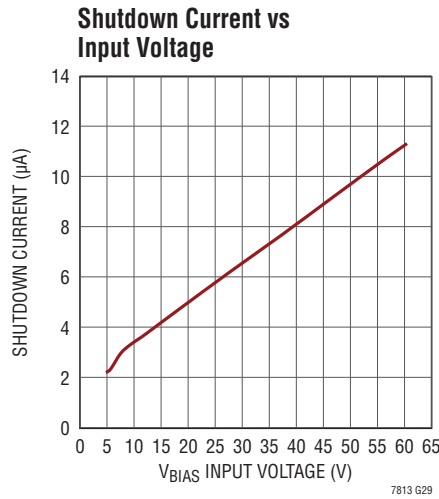
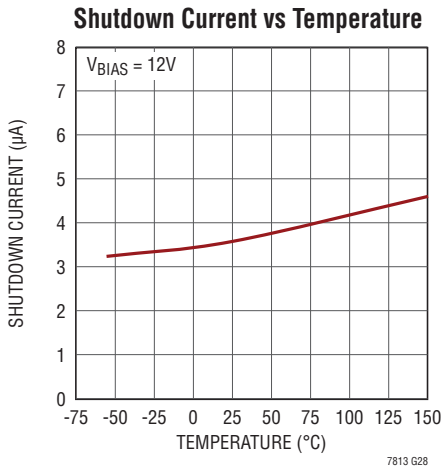

TYPICAL PERFORMANCE CHARACTERISTICS

Start-Up

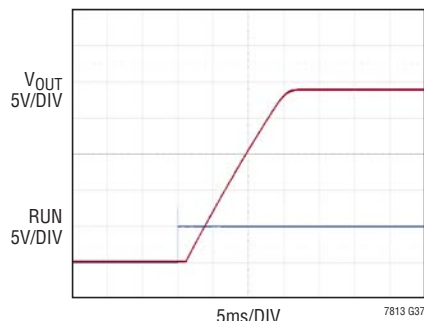

FIGURE 15 CIRCUIT

Buck Inductor Current at Light Load

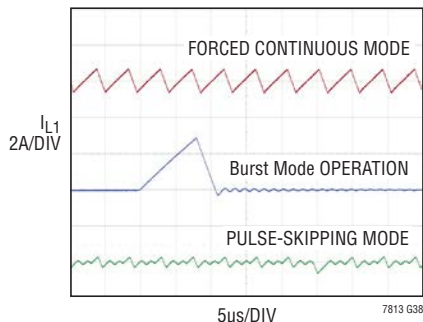

FIGURE 15 CIRCUIT

$V_{IN} = 32V$
 $V_{OUT} = 24V$
 $I_{OUT} = 1mA$

Boost Inductor Current at Light Load

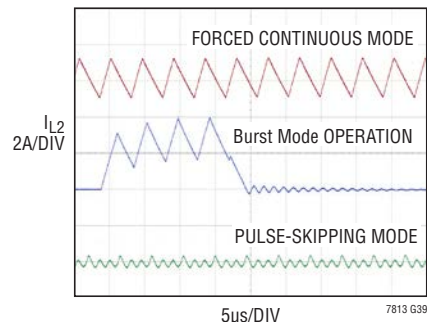

FIGURE 15 CIRCUIT

$V_{IN} = 18V$
 $V_{OUT} = 24V$
 $I_{OUT} = 1mA$

PIN FUNCTIONS

SW1, SW2 (Pins 1, 30): Switch Node Connections to Inductors.

TG1, TG2 (Pins 2, 29): High Current Gate Drives for Top N-Channel MOSFETs. These are the outputs of floating drivers with a voltage swing equal to DRV_{CC} superimposed on the switch node voltage SW.

TRACK/SS1, SS2 (Pins 3, 23): External Tracking and Soft-Start Input. For the buck channel, the LTC7813 regulates the V_{FB1} voltage to the smaller of 0.8V, or the voltage on the TRACK/SS1 pin. For the boost channel, the LTC7813 regulates the V_{FB2} voltage to the smaller of 1.2V, or the voltage on the SS2 pin. An internal $10\mu A$ pull-up current source is connected to this pin. A capacitor to ground at this pin sets the ramp time to final regulated output voltage. Alternatively, a resistor divider on another voltage supply connected to the TRACK/SS1 pin allows the LTC7813 buck output to track the other supply during start-up.

VPRG2 (Pin 4): Channel 2 Output Control Pin. This pin sets the boost channel to adjustable output mode using external feedback resistors or fixed 10V/12V output mode using internal resistive dividers. Grounding this pin allows the output to be programmed through the V_{FB2} pin using external resistors, regulating V_{FB2} to the 1.2V reference. Floating this pin or connecting it to $INTV_{CC}$ programs the output to 10V or 12V (respectively), with V_{FB2} used to sense the output voltage.

ITH1, ITH2 (Pins 5, 20): Error Amplifier Outputs and Switching Regulator Compensation Points. Each associated channel's current comparator trip point increases with this control voltage.

V_{FB1} (Pin 6): This pin receives the remotely sensed feedback voltage for the buck controller from an external resistive divider across the output.

SENSE1⁺, SENSE2⁺ (Pins 7, 12): The (+) Input to the Differential Current Comparators. The ITH pin voltage and controlled offsets between the SENSE⁻ and SENSE⁺ pins in conjunction with R_{SENSE} set the current trip threshold. For the boost channel, the SENSE2⁺ pin supplies current to the current comparator.

SENSE1⁻, SENSE2⁻ (Pins 8, 13): The (-) Input to the Differential Current Comparators. When SENSE1⁻ for the buck channel is greater than $INTV_{CC}$, the SENSE1⁻ pin supplies current to the current comparator.

FREQ (Pin 9): The frequency control pin for the internal VCO. Connecting this pin to GND forces the VCO to a fixed low frequency of 350kHz. Connecting this pin to $INTV_{CC}$ forces the VCO to a fixed high frequency of 535kHz. Other frequencies between 50kHz and 900kHz can be programmed using a resistor between FREQ and GND. The resistor and an internal $20\mu A$ source current create a voltage used by the internal oscillator to set the frequency.

7813f

PIN FUNCTIONS

PLLIN/MODE (Pin 10): External Synchronization Input to Phase Detector and Forced Continuous Mode Input. When an external clock is applied to this pin, the phase-locked loop will force the rising TG1 and BG2 signals to be synchronized with the rising edge of the external clock, and the regulators will operate in forced continuous mode. When not synchronizing to an external clock, this input, which acts on both controllers, determines how the LTC7813 operates at light loads. Pulling this pin to ground selects Burst Mode® operation. An internal 100k resistor to ground also invokes Burst Mode operation when the pin is floated. Tying this pin to INTV_{CC} forces continuous inductor current operation. Tying this pin to a voltage greater than 1.1V and less than INTV_{CC} – 1.3V selects pulse-skipping operation. This can be done by connecting a 100k resistor from this pin to INTV_{CC}.

GND (Pin 11, Exposed Pad Pin 33): Ground. The exposed pad must be soldered to the PCB for rated electrical and thermal performance.

PGOOD1 (Pin 14): Open-Drain Logic Output. PGOOD1 is pulled to ground when the voltage on the V_{FB1} pin is not within ±10% of its set point.

INTV_{CC} (Pin 15): Output of the Internal 5V Low Dropout Regulator. The low voltage analog and digital circuits are powered from this voltage source. A low ESR 0.1μF ceramic bypass capacitor should be connected between INTV_{CC} and GND, as close as possible to the IC.

RUN1, RUN2 (Pins 16, 17): Run Control Inputs for Each Controller. Forcing either of these pins below 1.2V shuts down that controller. Forcing both of these pins below 0.7V shuts down the entire LTC7813, reducing quiescent current to approximately 3.6μA.

ILIM (Pin 18): Current Comparator Sense Voltage Range Input. Tying this pin to GND or INTV_{CC} or floating it sets the maximum current sense threshold (for both channels) to one of three different levels (50mV, 100mV, or 75mV, respectively).

V_{FB2} (Pin 19): If VPRG2 is grounded, this pin receives the remotely sensed feedback voltage for the boost controller from an external resistive divider across the output. If VPRG2 is floated or tied to INTV_{CC}, this pin receives the remotely sensed output voltage of the boost controller.

DRVUV (Pin 21): Determines the higher or lower DRV_{CC} UVLO and EXTV_{CC} switchover thresholds, as listed on the Electrical Characteristics table. Connecting DRVUV to GND chooses the lower thresholds whereas tying DRVUV to INTV_{CC} chooses the higher thresholds.

DRVSET (Pin 22): Sets the regulated output voltage of the DRV_{CC} LDO regulator. Connecting this pin to GND sets DRV_{CC} to 6V whereas connecting it to INTV_{CC} sets DRV_{CC} to 10V. Voltages between 5V and 10V can be programmed by placing a resistor (50k to 100k) between the DRVSET pin and GND.

DRV_{CC} (Pin 24): Output of the Internal or External Low Dropout (LDO) Regulator. The gate drivers are powered from this voltage source. The DRV_{CC} voltage is set by the DRVSET pin. Must be decoupled to ground with a minimum of 4.7μF ceramic or other low ESR capacitor. Do not use the DRV_{CC} pin for any other purpose.

EXTV_{CC} (Pin 25): External Power Input to an Internal LDO Connected to DRV_{CC}. This LDO supplies DRV_{CC} power, bypassing the internal LDO powered from V_{BIAS} whenever EXTV_{CC} is higher than its switchover threshold (4.7V or 7.7V depending on the DRVSET pin). See EXTV_{CC} Connection in the Applications Information section. Do not float or exceed 14V on this pin. Do not connect EXTV_{CC} to a voltage greater than V_{BIAS}. Connect to GND if not used.

V_{BIAS} (Pin 26): Main Supply Pin. A bypass capacitor should be tied between this pin and the GND pin.

BG1, BG2 (Pins 31, 27): High Current Gate Drives for Bottom N-Channel MOSFETs. Voltage swing at these pins is from ground to DRV_{CC}.

BOOST1, BOOST2 (Pins 32, 28): Bootstrapped Supplies to the Topside Floating Drivers. Capacitors are connected between the BOOST and SW pins. Voltage swing at BOOST1 is from approximately DRV_{CC} to (V_{IN1} + DRV_{CC}). Voltage swing at BOOST2 is from approximately DRV_{CC} to (V_{OUT2} + DRV_{CC}).

FUNCTIONAL DIAGRAMS

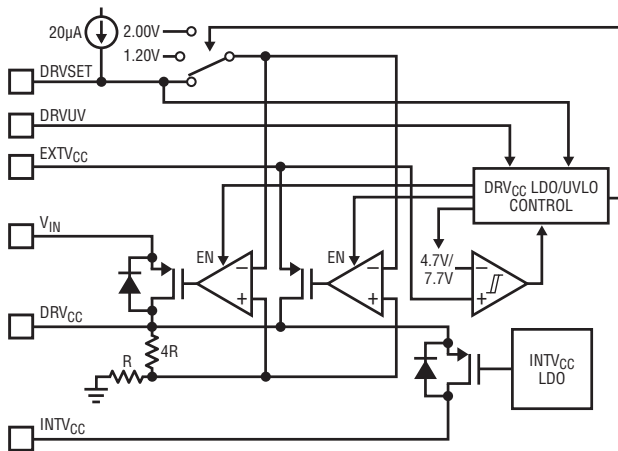
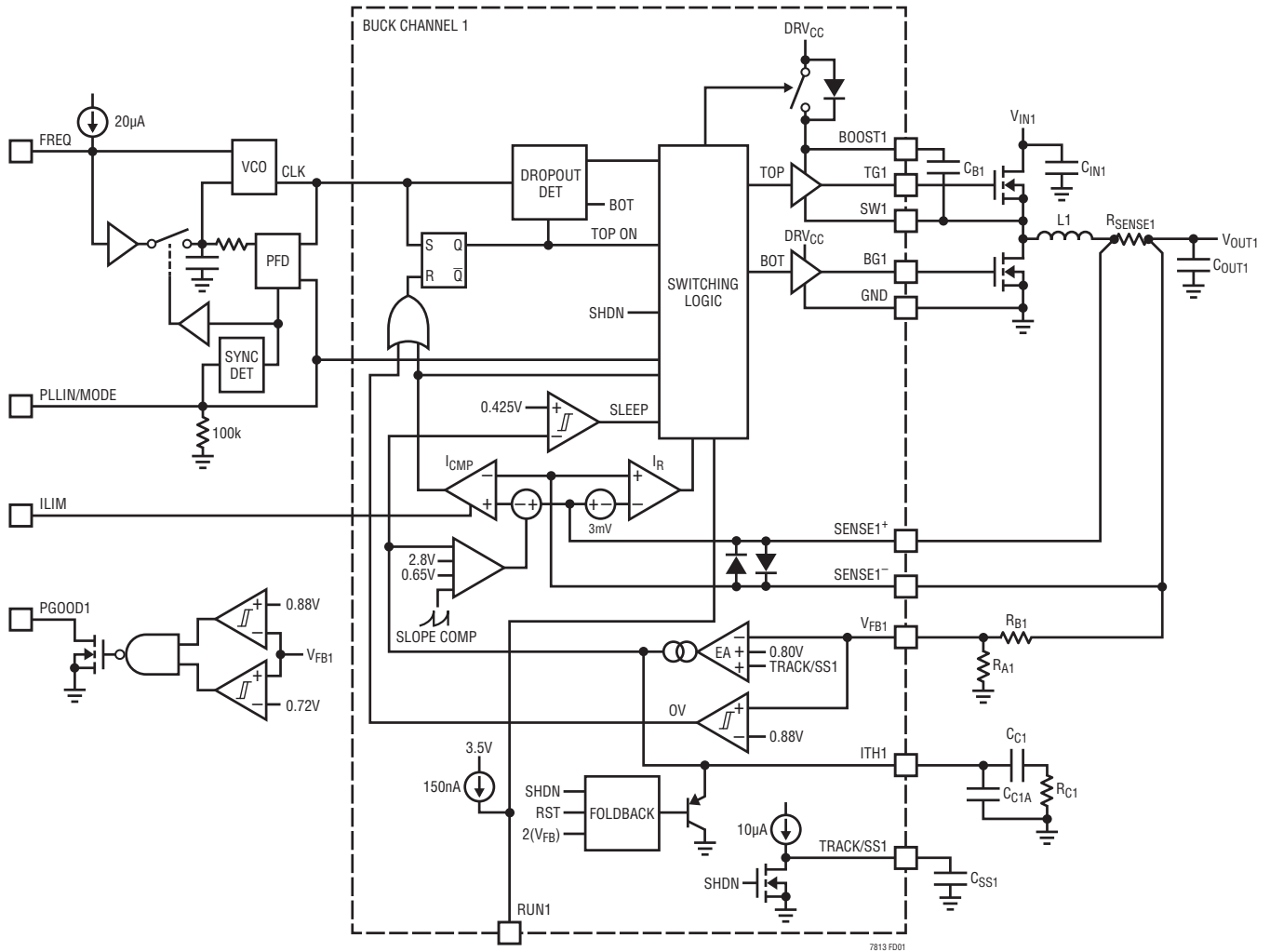

FUNCTIONAL DIAGRAMS

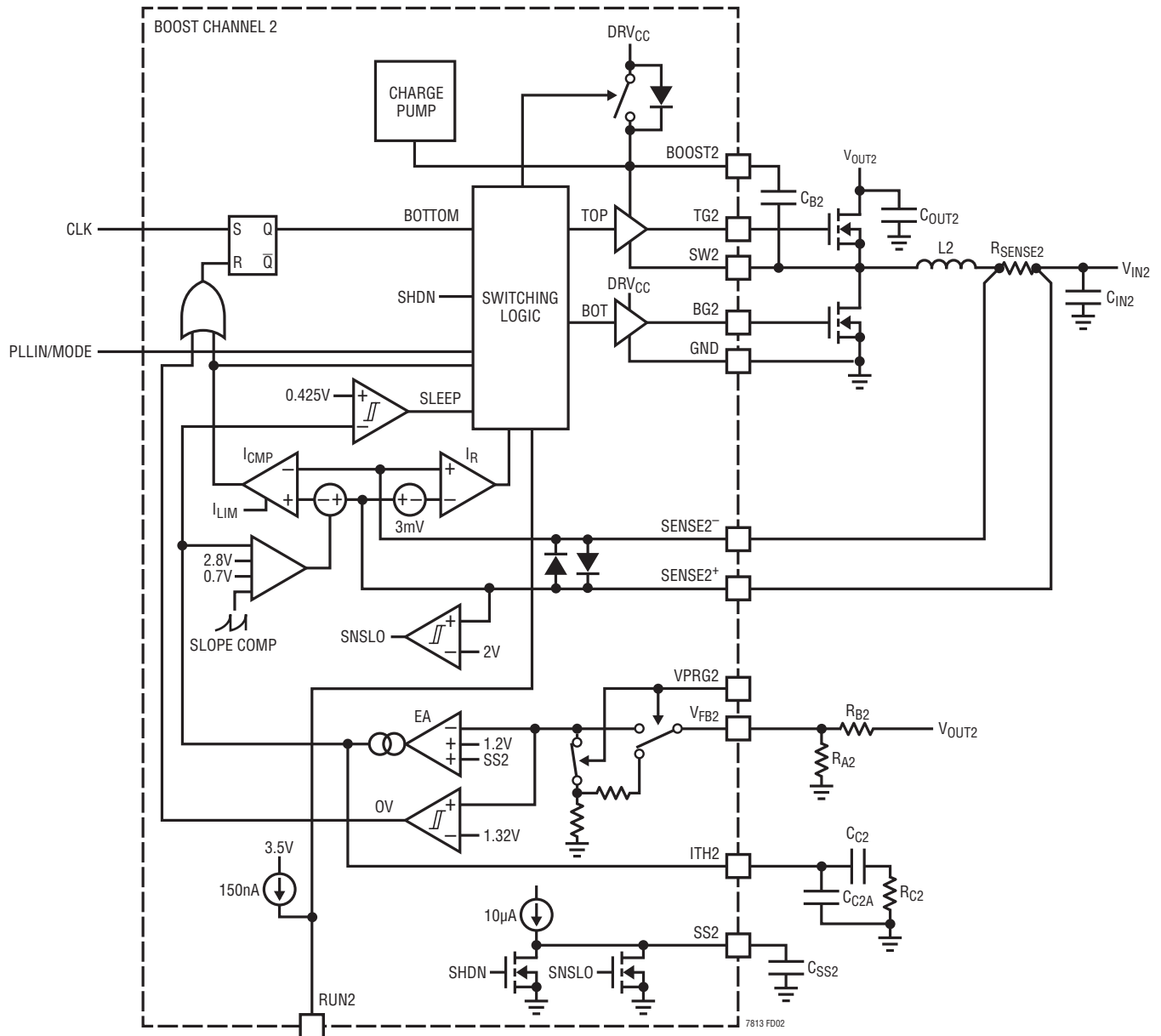

OPERATION (Refer to the Functional Diagrams)

Main Control Loop

The LTC7813 uses a constant frequency, current mode control architecture. Channel 1 is a buck (step-down) controller, and channel 2 is a boost (step-up) controller. During normal operation, the external top MOSFET for the buck channel (the external bottom MOSFET for the boost controller) is turned on when the clock for that channel sets the RS latch, and is turned off when the main current comparator, I_{CMP} , resets the RS latch. The peak inductor current at which I_{CMP} trips and resets the latch is controlled by the voltage on the ITH pin, which is the output of the error amplifier, EA. The error amplifier compares the output voltage feedback signal at the V_{FB} pin (which is generated with an external resistor divider connected across the output voltage, V_{OUT} , to ground) to the internal 0.800V reference voltage (1.2V reference voltage for the boost). When the load current increases, it causes a slight decrease in V_{FB} relative to the reference, which causes the EA to increase the ITH voltage until the average inductor current matches the new load current.

After the top MOSFET for the buck (the bottom MOSFET for the boost) is turned off each cycle, the bottom MOSFET is turned on (the top MOSFET for the boost) until either the inductor current starts to reverse, as indicated by the current comparator I_R , or the beginning of the next clock cycle.

DRV_{CC}/EXTV_{CC}/INTV_{CC} Power

Power for the top and bottom MOSFET drivers is derived from the DRV_{CC} pin. The DRV_{CC} supply voltage can be programmed from 5V to 10V through control of the DRVSET pin. When the EXTV_{CC} pin is tied to a voltage below its switchover voltage (4.7V or 7.7V depending on the DRVUV voltage), the V_{BIAS} LDO (low dropout linear regulator) supplies power from V_{BIAS} to DRV_{CC}. If EXTV_{CC} is taken above its switchover voltage, the V_{BIAS} LDO is turned off and an EXTV_{CC} LDO is turned on. Once enabled, the EXTV_{CC} LDO supplies power from EXTV_{CC} to DRV_{CC}. Using the EXTV_{CC} pin allows the DRV_{CC} power to be derived from a high efficiency external source such as the LTC7813 buck regulator output.

Each top MOSFET driver is biased from the floating bootstrap capacitor, C_B , which normally recharges during each cycle through an internal switch whenever SW goes low.

For buck channel 1, if the input voltage decreases to a voltage close to its output, the loop may enter dropout and attempt to turn on the top MOSFET continuously. The dropout detector detects this and forces the top MOSFET off for about one-twelfth of the clock period every tenth cycle to allow C_B to recharge, resulting in about 99% duty cycle.

The INTV_{CC} supply powers most of the other internal circuits in the LTC7813. The INTV_{CC} LDO regulates to a fixed value of 5V and its power is derived from the DRV_{CC} supply.

Shutdown and Start-Up (RUN, TRACK/SS Pins)

The two channels of the LTC7813 can be independently shut down using the RUN1 and RUN2 pins. Pulling a RUN pin below 1.22V shuts down the main control loop for that channel. Pulling both pins below 0.7V disables both controllers and most internal circuits, including the DRV_{CC} and INTV_{CC} LDOs. In this state, the LTC7813 draws only 3.6 μ A of quiescent current.

Releasing a RUN pin allows a small 150nA internal current to pull up the pin to enable that controller. Each RUN pin may be externally pulled up or driven directly by logic. Each RUN pin can tolerate up to 65V (absolute maximum), so it can be conveniently tied to V_{BIAS} in always-on applications where one or both controllers are enabled continuously and never shut down.

The start-up of each controller's output voltage V_{OUT} is controlled by the voltage on the TRACK/SS pin (TRACK/SS1 for channel 1, SS2 for channel 2). When the voltage on the TRACK/SS pin is less than the 0.8V internal reference for the buck and the 1.2V internal reference for the boost, the LTC7813 regulates the V_{FB} voltage to the TRACK/SS pin voltage instead of the corresponding reference voltage. This allows the TRACK/SS pin to be used to program a soft-start by connecting an external capacitor from the TRACK/SS pin to GND. An internal 10 μ A pull-up current charges this capacitor creating a voltage ramp on the TRACK/SS pin. As the TRACK/SS voltage rises linearly from 0V to 0.8V/1.2V (and beyond up to about 4V), the output voltage V_{OUT} rises smoothly from zero (V_{IN} for the boost) to its final value.

OPERATION (Refer to the Functional Diagrams)

Alternatively the TRACK/SS1 pin for the buck channel can be used to cause the start-up of V_{OUT1} to track that of another supply. Typically, this requires connecting to the TRACK/SS1 pin an external resistor divider from the other supply to ground (see the Applications Information section).

Light Load Current Operation (Burst Mode Operation, Pulse-Skipping or Forced Continuous Mode) (PLLIN/MODE Pin)

The LTC7813 can be enabled to enter high efficiency Burst Mode operation, constant frequency pulse-skipping mode, or forced continuous conduction mode at low load currents. To select Burst Mode operation, tie the PLLIN/MODE pin to GND. To select forced continuous operation, tie the PLLIN/MODE pin to $INTV_{CC}$. To select pulse-skipping mode, tie the PLLIN/MODE pin to a DC voltage greater than 1.1V and less than $INTV_{CC} - 1.3V$. This can be done by connecting a 100k Ω resistor between PLLIN/MODE and $INTV_{CC}$.

When a controller is enabled for Burst Mode operation, the minimum peak current in the inductor is set to approximately 25% of the maximum sense voltage (30% for the boost) even though the voltage on the ITH pin indicates a lower value. If the average inductor current is higher than the load current, the error amplifier, EA, will decrease the voltage on the ITH pin. When the ITH voltage drops below 0.425V, the internal sleep signal goes high (enabling sleep mode) and both external MOSFETs are turned off. The ITH pin is then disconnected from the output of the EA and parked at 0.450V.

In sleep mode, much of the internal circuitry is turned off, reducing the quiescent current that the LTC7813 draws. If one channel is in sleep mode and the other is shut down, the LTC7813 draws only 29 μ A of quiescent current (with $DRVSET = 0V$). If both controllers are enabled in sleep mode, the LTC7813 draws only 34 μ A of quiescent current. In sleep mode, the load current is supplied by the output capacitor. As the output voltage decreases, the EA's output begins to rise. When the output voltage drops enough, the ITH pin is reconnected to the output of the EA, the sleep signal goes low, and the controller resumes normal operation by turning on the top external MOSFET (the bottom external MOSFET for the boost) on the next cycle of the internal oscillator.

When a controller is enabled for Burst Mode operation, the inductor current is not allowed to reverse. The reverse current comparator (I_R) turns off the bottom external MOSFET (the top external MOSFET for the boost) just before the inductor current reaches zero, preventing it from reversing and going negative. Thus, the controller operates discontinuously.

In forced continuous operation, the inductor current is allowed to reverse at light loads or under large transient conditions. The peak inductor current is determined by the voltage on the ITH pin, just as in normal operation. In this mode, the efficiency at light loads is lower than in Burst Mode operation. However, continuous operation has the advantage of lower output voltage ripple and less interference to audio circuitry. In forced continuous mode, the output ripple is independent of load current. Clocking the LTC7813 from an external source enables forced continuous mode (see the Frequency Selection and Phase-Locked Loop section).

When the PLLIN/MODE pin is connected for pulse-skipping mode, the LTC7813 operates in PWM pulse-skipping mode at light loads. In this mode, constant frequency operation is maintained down to approximately 1% of designed maximum output current. At very light loads, the current comparator, I_{CMP} , may remain tripped for several cycles and force the external top MOSFET (bottom for the boost) to stay off for the same number of cycles (i.e., skipping pulses). The inductor current is not allowed to reverse (discontinuous operation). This mode, like forced continuous operation, exhibits low output ripple as well as low audio noise and reduced RF interference as compared to Burst Mode operation. It provides higher low current efficiency than forced continuous mode, but not nearly as high as Burst Mode operation.

Frequency Selection and Phase-Locked Loop (FREQ and PLLIN/MODE Pins)

The selection of switching frequency is a trade-off between efficiency and component size. Low frequency operation increases efficiency by reducing MOSFET switching losses, but requires larger inductance and/or capacitance to maintain low output ripple voltage.

OPERATION (Refer to the Functional Diagrams)

The switching frequency of the LTC7813's controllers can be selected using the FREQ pin.

If the PLLIN/MODE pin is not being driven by an external clock source, the FREQ pin can be tied to GND, tied to INTV_{CC} or programmed through an external resistor. Tying FREQ to GND selects 350kHz while tying FREQ to INTV_{CC} selects 535kHz. Placing a resistor between FREQ and GND allows the frequency to be programmed between 50kHz and 900kHz, as shown in Figure 10.

A phase-locked loop (PLL) is available on the LTC7813 to synchronize the internal oscillator to an external clock source that is connected to the PLLIN/MODE pin. The LTC7813's phase detector adjusts the voltage (through an internal lowpass filter) of the VCO input to align the turn-on of TG1 and BG2 to the rising edge of the synchronizing signal.

The VCO input voltage is prebiased to the operating frequency set by the FREQ pin before the external clock is applied. If prebiased near the external clock frequency, the PLL loop only needs to make slight changes to the VCO input in order to synchronize the rising edge of the external clock's to the rising edge of TG1 and BG2. The ability to prebias the loop filter allows the PLL to lock-in rapidly without deviating far from the desired frequency.

The typical capture range of the LTC7813's phase-locked loop is from approximately 55kHz to 1MHz, with a guarantee to be between 75kHz and 850kHz. In other words, the LTC7813's PLL is guaranteed to lock to an external clock source whose frequency is between 75kHz and 850kHz.

The typical input clock thresholds on the PLLIN/MODE pin are 1.6V (rising) and 1.1V (falling). It is recommended that the external clock source swings from ground (0V) to at least 2.5V.

Boost Controller Operation When $V_{IN2} > V_{OUT2}$

When the input voltage to the boost channel rises above its regulated V_{OUT2} voltage, the controller can behave differently depending on the mode, inductor current and V_{IN2} voltage. In forced continuous mode, the loop works

to keep the top MOSFET on continuously once V_{IN2} rises above V_{OUT2} . An internal charge pump delivers current to the boost capacitor from the BOOST2 pin to maintain a sufficiently high TG2 voltage. Because the LTC7813 uses internal switches and does not require external bootstrap diodes, the charge pump only has to overcome small leakage currents (board leakage, etc.).

In pulse-skipping mode, if V_{IN} is between 0% and 10% above the regulated V_{OUT2} voltage, TG2 turns on if the inductor current rises above approximately 3% of the programmed I_{LIM} current. If the part is programmed in Burst Mode operation under this same V_{IN2} window, then TG2 turns on at the same threshold current as long as the chip is awake (the buck channel is awake and switching). If the buck channel is asleep or shut down in this V_{IN2} window, then TG2 will remain off regardless of the inductor current.

If V_{IN} rises more than 10% above the regulated V_{OUT} voltage in any mode, the controller turns on TG2 regardless of the inductor current. In Burst Mode operation, however, the internal charge pump turns off if the entire chip is asleep (if the buck channel is also asleep or shut down). With the charge pump off, there would be nothing to prevent the boost capacitor from discharging, resulting in an insufficient TG2 voltage needed to keep the top MOSFET completely on. The charge pump turns back on when the chip wakes up, and it remains on as long as the buck channel is actively switching.

Boost Controller at Low SENSE Pin Common Voltage

The current comparator of the boost controller is powered directly from the SENSE2⁺ pin and can operate to voltages as low as 2.2V. Since this is lower than the V_{BIAS} UVLO of the chip, V_{BIAS} can be connected to the output of the boost controller, as illustrated in the typical application circuit in Figure 12. This allows the boost controller to handle input voltage transients down to 2.2V while maintaining output voltage regulation. If SENSE2⁺ falls below 2.0V, then switching stops and SS2 is pulled low. If SENSE2⁺ rises back above 2.2V, the SS2 pin will be released, initiating a new soft-start sequence.

OPERATION (Refer to the Functional Diagrams)

Buck Controller Output Overvoltage Protection

The buck channel has an overvoltage comparator that guards against transient overshoots as well as other more serious conditions that may overvoltage the output. When the V_{FB1} pin rises by more than 10% above its regulation point of 0.800V, the top MOSFET is turned off and the bottom MOSFET is turned on until the overvoltage condition is cleared.

Buck Foldback Current

When the buck output voltage falls to less than 70% of its nominal level, foldback current limiting is activated, progressively lowering the peak current limit in proportion to the severity of the overcurrent or short-circuit condition. Foldback current limiting is disabled during the soft-start interval (as long as the V_{FB1} voltage is keeping up with the TRACK/SS1 voltage). There is no foldback current limiting for the boost channel.

APPLICATIONS INFORMATION

Cascaded Boost+Buck Regulator

The LTC7813 can be configured to regulate two separate, completely independent outputs, one boost and one buck. Or, it can be configured as a cascaded Boost+Buck single output converter that regulates an output voltage from an input voltage that can be above, below, or equal to the output voltage. When cascaded, the input voltage feeds the boost regulator, which generates an intermediate node supply (V_{MID}) that then serves as the input to the buck regulator, which then regulates the output voltage.

When used as a cascaded Boost+Buck regulator, the LTC7813 has distinct advantages compared to traditional single inductor buck-boost regulators. Even though it requires two inductors, these inductors are individually smaller and provide inherent filtering at the input and output, substantially reducing conducted EMI and voltage ripple, thereby requiring less input and output filtering. Even though they are cascaded, the boost and buck regulators are independently optimized and compensated. The buck regulator provides a very fast transient response compared to a buck-boost regulator, further reducing the amount of output capacitance that is required. The LTC7813 also features a very low quiescent current Burst Mode which dramatically reduces power loss and increases efficiency at light loads. Thus, for those applications that require low EMI, low ripple, fast transient response, low quiescent current, and/or high light load efficiency, the LTC7813 cascaded Boost+Buck regulator provides an excellent solution.

The Typical Application on the first page is a basic LTC7813 application circuit. LTC7813 can be configured to use either DCR (inductor resistance) sensing or low value resistor sensing. The choice between the two current sensing schemes is largely a design trade-off between cost, power consumption and accuracy. DCR sensing has become popular because it saves expensive current sensing resistors and is more power efficient, especially in high current applications. However, current sensing resistors provide the most accurate current limits for the controller. Other external component selection is driven by the load requirement, and begins with the selection of R_{SENSE} (if R_{SENSE} is used) and inductor value. Next, the

power MOSFETs are selected. Finally, input and output capacitors are selected.

SENSE+ and SENSE- Pins

The SENSE+ and SENSE- pins are the inputs to the current comparators.

Buck Controller (SENSE1+/SENSE1-): The common mode voltage range on these pins is 0V to 65V (absolute maximum), enabling the LTC7813 to regulate buck output voltages up to a nominal 60V set point (allowing margin for tolerances and transients). The SENSE1+ pin is high impedance over the full common mode range, drawing at most $\pm 1\mu\text{A}$. This high impedance allows the current comparators to be used in inductor DCR sensing. The impedance of the SENSE1- pin changes depending on the common mode voltage. When SENSE1- is less than $\text{INTV}_{CC} - 0.5\text{V}$, a small current of less than $1\mu\text{A}$ flows out of the pin. When SENSE1- is above $\text{INTV}_{CC} + 0.5\text{V}$, a higher current ($\approx 700\mu\text{A}$) flows into the pin. Between $\text{INTV}_{CC} - 0.5\text{V}$ and $\text{INTV}_{CC} + 0.5\text{V}$, the current transitions from the smaller current to the higher current.

Boost Controller (SENSE2+/SENSE2-): The common mode input range for these pins is 2.2V to 60V, allowing the boost converter to operate from inputs over this full range. The SENSE2+ pin also provides power to the current comparator and draws about $170\mu\text{A}$ during normal operation (when not shut down or asleep in Burst Mode operation). There is a small bias current of less than $1\mu\text{A}$ that flows into the SENSE2- pin. This high impedance on the SENSE2- pin allows the current comparator to be used in inductor DCR sensing.

Filter components mutual to the sense lines should be placed close to the LTC7813, and the sense lines should run close together to a Kelvin connection underneath the current sense element (shown in Figure 1). Sensing current elsewhere can effectively add parasitic inductance and capacitance to the current sense element, degrading the information at the sense terminals and making the programmed current limit unpredictable. If DCR sensing is used (Figure 2b), R1 should be placed close to the switching node, to prevent noise from coupling into sensitive small-signal nodes.

APPLICATIONS INFORMATION

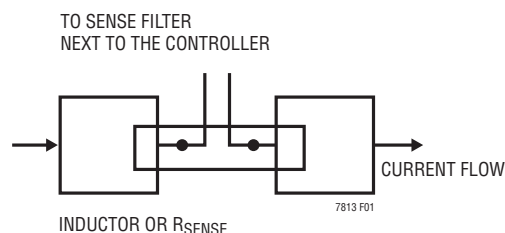

Figure 1. Sense Lines Placement with Inductor or Sense Resistor

Low Value Resistor Current Sensing

A typical sensing circuit using a discrete resistor is shown in Figure 2a. R_{SENSE} is chosen based on the required output current.

The current comparators have a maximum threshold $V_{SENSE(MAX)}$ of 50mV, 75mV or 100mV. The current comparator threshold voltage sets the peak of the inductor current, yielding a maximum average output current, I_{MAX} , equal to the peak value less half the peak-to-peak ripple current, ΔI_L . To calculate the sense resistor value, use the equation:

$$R_{SENSE} = \frac{V_{SENSE(MAX)}}{I_{MAX} + \frac{\Delta I_L}{2}}$$

When using the buck controller in very low dropout conditions, the maximum output current level will be reduced due to the internal compensation required to meet stability criteria for buck regulators operating at greater than 50% duty factor. A curve is provided in the Typical Performance Characteristics section to estimate this reduction in peak inductor current depending upon the operating duty factor.

Inductor DCR Sensing

For applications requiring the highest possible efficiency at high load currents, the LTC7813 is capable of sensing the voltage drop across the inductor DCR, as shown in Figure 2b. The DCR of the inductor represents the small amount of DC winding resistance of the copper, which can be less than 1mΩ for today's low value, high current inductors. In a high current application requiring such an inductor, power loss through a sense resistor would cost several points of efficiency compared to inductor DCR sensing.

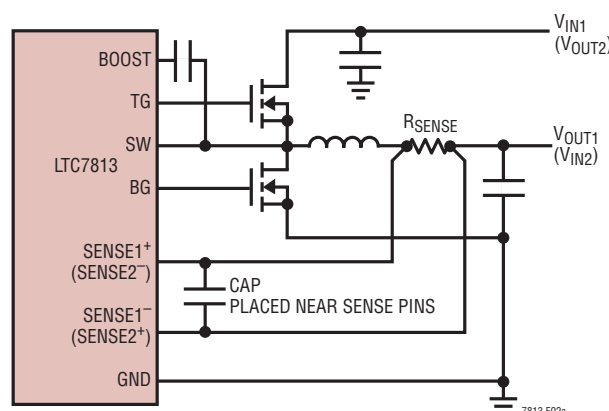

(2a) Using a Resistor to Sense Current

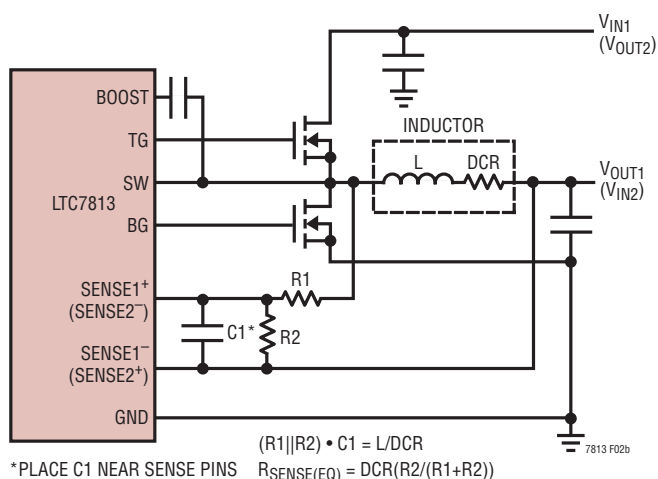

(2b) Using the Inductor DCR to Sense Current

Figure 2. Current Sensing Methods

If the external $(R1 || R2) \cdot C1$ time constant is chosen to be exactly equal to the L / DCR time constant, the voltage drop across the external capacitor is equal to the drop across the inductor DCR multiplied by $R2 / (R1 + R2)$. $R2$ scales the voltage across the sense terminals for applications where the DCR is greater than the target sense resistor value. To properly dimension the external filter components, the DCR of the inductor must be known. It can be measured using a good RLC meter, but the DCR tolerance is not always the same and varies with temperature; consult the manufacturers' data sheets for detailed information.

APPLICATIONS INFORMATION

Using the inductor ripple current value from the Inductor Value Calculation section, the target sense resistor value is:

$$R_{\text{SENSE(EQUIV)}} = \frac{V_{\text{SENSE(MAX)}}}{I_{\text{MAX}} + \frac{\Delta I_L}{2}}$$

To ensure that the application will deliver full load current over the full operating temperature range, choose the minimum value for $V_{\text{SENSE(MAX)}}$ in the Electrical Characteristics table.

Next, determine the DCR of the inductor. When provided, use the manufacturer's maximum value, usually given at 20°C. Increase this value to account for the temperature coefficient of copper resistance, which is approximately 0.4%/°C. A conservative value for $T_{L(\text{MAX})}$ is 100°C.

To scale the maximum inductor DCR to the desired sense resistor value (R_D), use the divider ratio:

$$R_D = \frac{R_{\text{SENSE(EQUIV)}}}{\text{DCR}_{\text{MAX}} \text{ at } T_{L(\text{MAX})}}$$

C_1 is usually selected to be in the range of 0.1µF to 0.47µF. This forces $R_1 || R_2$ to around 2k, reducing error that might have been caused by the SENSE1+/SENSE2- pin's ±1µA current.

The equivalent resistance $R_1 || R_2$ is scaled to the temperature inductance and maximum DCR:

$$R_1 || R_2 = \frac{L}{(\text{DCR at } 20^\circ\text{C}) \cdot C_1}$$

The sense resistor values are:

$$R_1 = \frac{R_1 || R_2}{R_D}; \quad R_2 = \frac{R_1 \cdot R_D}{1 - R_D}$$

The maximum power loss in R_1 is related to duty cycle, and will occur in continuous mode at the maximum input voltage:

$$P_{\text{LOSS } R_1} = \frac{(V_{\text{IN(MAX)}} - V_{\text{OUT}}) \cdot V_{\text{OUT}}}{R_1}$$

For the boost controller, the maximum power loss in R_1 will occur in continuous mode at $V_{\text{IN}} = 1/2 \cdot V_{\text{OUT}}$:

$$P_{\text{LOSS } R_1} = \frac{(V_{\text{OUT(MAX)}} - V_{\text{IN}}) \cdot V_{\text{IN}}}{R_1}$$

Ensure that R_1 has a power rating higher than this value. If high efficiency is necessary at light loads, consider this power loss when deciding whether to use DCR sensing or sense resistors. Light load power loss can be modestly higher with a DCR network than with a sense resistor, due to the extra switching losses incurred through R_1 . However, DCR sensing eliminates a sense resistor, reduces conduction losses and provides higher efficiency at heavy loads. Peak efficiency is about the same with either method.

Inductor Value Calculation

The operating frequency and inductor selection are inter-related in that higher operating frequencies allow the use of smaller inductor and capacitor values. So why would anyone ever choose to operate at lower frequencies with larger components? The answer is efficiency. A higher frequency generally results in lower efficiency because of MOSFET switching and gate charge losses. In addition to this basic trade-off, the effect of inductor value on ripple current and low current operation must also be considered.

The inductor value has a direct effect on ripple current. The inductor ripple current, ΔI_L , decreases with higher inductance or higher frequency. For the buck controllers, ΔI_L increases with higher V_{IN} :

$$\Delta I_L = \frac{1}{(f)(L)} V_{\text{OUT}} \left(1 - \frac{V_{\text{OUT}}}{V_{\text{IN}}} \right)$$

For the boost controller, ΔI_L increases with higher V_{OUT} :

$$\Delta I_L = \frac{1}{(f)(L)} V_{\text{IN}} \left(1 - \frac{V_{\text{IN}}}{V_{\text{OUT}}} \right)$$

Accepting larger values of ΔI_L allows the use of low inductances, but results in higher output voltage ripple and greater core losses. A reasonable starting point for setting ripple current is $\Delta I_L = 0.3(I_{\text{MAX}})$. The maximum ΔI_L occurs at the maximum input voltage for the bucks and $V_{\text{IN}} = 1/2 \cdot V_{\text{OUT}}$ for the boost.

APPLICATIONS INFORMATION

The inductor value also has secondary effects. The transition to Burst Mode operation begins when the average inductor current required results in a peak current below 25% of the current limit (30% for the boost) determined by R_{SENSE} . Lower inductor values (higher ΔI_L) will cause this to occur at lower load currents, which can cause a dip in efficiency in the upper range of low current operation. In Burst Mode operation, lower inductance values will cause the burst frequency to decrease.

Inductor Core Selection

Once the value for L is known, the type of inductor must be selected. High efficiency converters generally cannot afford the core loss found in low cost powdered iron cores, forcing the use of more expensive ferrite or molypermalloy cores. Actual core loss is independent of core size for a fixed inductor value, but it is very dependent on inductance value selected. As inductance increases, core losses go down. Unfortunately, increased inductance requires more turns of wire and therefore copper losses will increase.

Ferrite designs have very low core loss and are preferred for high switching frequencies, so design goals can concentrate on copper loss and preventing saturation. Ferrite core material saturates hard, which means that inductance collapses abruptly when the peak design current is exceeded. This results in an abrupt increase in inductor ripple current and consequent output voltage ripple. Do not allow the core to saturate!

Power MOSFET Selection

Two external power MOSFETs must be selected for each controller in the LTC7813: one N-channel MOSFET for the top switch (main switch for the buck, synchronous for the boost), and one N-channel MOSFET for the bottom switch (main switch for the boost, synchronous for the buck).

The peak-to-peak drive levels are set by the DRV_{CC} voltage. This voltage can range from 5V to 10V depending on configuration of the DRVSET pin. Therefore, both logic-level and standard-level threshold MOSFETs can be used in most applications depending on the programmed DRV_{CC} voltage. Pay close attention to the BV_{DSS} specification for the MOSFETs as well.

The LTC7813's unique ability to adjust the gate drive level between 5V to 10V (OPTI-DRIVE) allows an application circuit to be precisely optimized for efficiency. When adjusting the gate drive level, the final arbiter is the total input current for the regulator. If a change is made and the input current decreases, then the efficiency has improved. If there is no change in input current, then there is no change in efficiency.

Selection criteria for the power MOSFETs include the on-resistance $R_{DS(ON)}$, Miller capacitance C_{MILLER} , input voltage and maximum output current. Miller capacitance, C_{MILLER} , can be approximated from the gate charge curve usually provided on the MOSFET manufacturers' data sheet. C_{MILLER} is equal to the increase in gate charge along the horizontal axis while the curve is approximately flat divided by the specified change in V_{DS} . This result is then multiplied by the ratio of the application applied V_{DS} to the gate charge curve specified V_{DS} . When the IC is operating in continuous mode the duty cycles for the top and bottom MOSFETs are given by:

$$\text{Buck Main Switch Duty Cycle} = \frac{V_{OUT}}{V_{IN}}$$

$$\text{Buck Sync Switch Duty Cycle} = \frac{V_{IN} - V_{OUT}}{V_{IN}}$$

$$\text{Boost Main Switch Duty Cycle} = \frac{V_{OUT} - V_{IN}}{V_{OUT}}$$

$$\text{Boost Sync Switch Duty Cycle} = \frac{V_{IN}}{V_{OUT}}$$

APPLICATIONS INFORMATION

The MOSFET power dissipations at maximum output current are given by:

$$P_{\text{MAIN_BUCK}} = \frac{V_{\text{OUT}}}{V_{\text{IN}}} (I_{\text{OUT(MAX)}})^2 (1 + \delta) R_{\text{DS(ON)}} + (V_{\text{IN}})^2 \left(\frac{I_{\text{OUT(MAX)}}}{2} \right) (R_{\text{DR}}) (C_{\text{MILLER}}) \cdot \left[\frac{1}{V_{\text{DRVCC}} - V_{\text{THMIN}}} + \frac{1}{V_{\text{THMIN}}} \right] (f)$$

$$P_{\text{SYNC_BUCK}} = \frac{V_{\text{IN}} - V_{\text{OUT}}}{V_{\text{IN}}} (I_{\text{OUT(MAX)}})^2 (1 + \delta) R_{\text{DS(ON)}}$$

$$P_{\text{MAIN_BOOST}} = \frac{(V_{\text{OUT}} - V_{\text{IN}}) V_{\text{OUT}}}{V_{\text{IN}}^2} (I_{\text{OUT(MAX)}})^2 \cdot (1 + \delta) R_{\text{DS(ON)}} + \left(\frac{V_{\text{OUT}}^3}{V_{\text{IN}}} \right) \left(\frac{I_{\text{OUT(MAX)}}}{2} \right) \cdot (R_{\text{DR}}) (C_{\text{MILLER}}) \cdot \left[\frac{1}{V_{\text{DRVCC}} - V_{\text{THMIN}}} + \frac{1}{V_{\text{THMIN}}} \right] (f)$$

$$P_{\text{SYNC_BOOST}} = \frac{V_{\text{IN}}}{V_{\text{OUT}}} (I_{\text{OUT(MAX)}})^2 (1 + \delta) R_{\text{DS(ON)}}$$

where δ is the temperature dependency of $R_{\text{DS(ON)}}$ and R_{DR} (approximately 2Ω) is the effective driver resistance at the MOSFET's Miller threshold voltage. V_{THMIN} is the typical MOSFET minimum threshold voltage.

Both MOSFETs have I^2R losses while the main N-channel equations for the buck and boost controllers include an additional term for transition losses, which are highest at high input voltages for the buck and low input voltages for the boost. For $V_{\text{IN}} < 20\text{V}$ (higher V_{IN} for the boost) the high current efficiency generally improves with larger MOSFETs, while for $V_{\text{IN}} > 20\text{V}$ (lower V_{IN} for the boost) the transition losses rapidly increase to the point that the use of a higher $R_{\text{DS(ON)}}$ device with lower C_{MILLER} actually provides higher efficiency. The synchronous MOSFET losses for the buck controller are greatest at high input voltage when the top switch duty factor is low or during a short-circuit when the synchronous switch is on close to 100% of the period.

The term $(1 + \delta)$ is generally given for a MOSFET in the form of a normalized $R_{\text{DS(ON)}}$ vs Temperature curve, but $\delta = 0.005/^\circ\text{C}$ can be used as an approximation for low voltage MOSFETs.

Boost C_{IN} , C_{OUT} Selection

The input ripple current in a boost converter is relatively low (compared with the output ripple current), because this current is continuous. The boost input capacitor C_{IN} voltage rating should comfortably exceed the maximum input voltage. Although ceramic capacitors can be relatively tolerant of overvoltage conditions, aluminum electrolytic capacitors are not. Be sure to characterize the input voltage for any possible overvoltage transients that could apply excess stress to the input capacitors.

The value of C_{IN} is a function of the source impedance, and in general, the higher the source impedance, the higher the required input capacitance. The required amount of input capacitance is also greatly affected by the duty cycle. High output current applications that also experience high duty cycles can place great demands on the input supply, both in terms of DC current and ripple current.

In a boost converter, the output has a discontinuous current, so C_{OUT} must be capable of reducing the output voltage ripple. The effects of ESR (equivalent series resistance) and the bulk capacitance must be considered when choosing the right capacitor for a given output ripple voltage. The steady ripple due to charging and discharging the bulk capacitance is given by:

$$\text{Ripple} = \frac{I_{\text{OUT(MAX)}} \cdot (V_{\text{OUT}} - V_{\text{IN(MIN)}})}{C_{\text{OUT}} \cdot V_{\text{OUT}} \cdot f} V$$

where C_{OUT} is the output filter capacitor.

The steady ripple due to the voltage drop across the ESR is given by:

$$\Delta V_{\text{ESR}} = I_{\text{L(MAX)}} \cdot \text{ESR}$$

Multiple capacitors placed in parallel may be needed to meet the ESR and RMS current handling requirements. Dry tantalum, special polymer, aluminum electrolytic and ceramic capacitors are all available in surface mount

APPLICATIONS INFORMATION

packages. Ceramic capacitors have excellent low ESR characteristics but can have a high voltage coefficient. Capacitors are now available with low ESR and high ripple current ratings such as OS-CON and POSCAP.

Buck C_{IN} , C_{OUT} Selection

The selection of C_{IN} is usually based off the worst-case RMS input current. The highest $(V_{OUT})(I_{OUT})$ product needs to be used in the formula shown in Equation 1 to determine the maximum RMS capacitor current requirement.

In continuous mode, the source current of the top MOSFET is a square wave of duty cycle $(V_{OUT})/(V_{IN})$. To prevent large voltage transients, a low ESR capacitor sized for the maximum RMS current of one channel must be used. The maximum RMS capacitor current is given by:

$$C_{IN} \text{ Required } I_{RMS} \approx \frac{I_{MAX}}{V_{IN}} [(V_{OUT})(V_{IN} - V_{OUT})]^{1/2} \quad (1)$$

This formula has a maximum at $V_{IN} = 2V_{OUT}$, where $I_{RMS} = I_{OUT}/2$. This simple worst-case condition is commonly used for design because even significant deviations do not offer much relief. Note that capacitor manufacturers' ripple current ratings are often based on only 2000 hours of life. This makes it advisable to further derate the capacitor, or to choose a capacitor rated at a higher temperature than required. Several capacitors may be paralleled to meet size or height requirements in the design. Due to the high operating frequency of the LTC7813, ceramic capacitors can also be used for C_{IN} . Always consult the manufacturer if there is any question.

A small (0.1 μ F to 1 μ F) bypass capacitor between the chip V_{IN} pin and ground, placed close to the LTC7813, is also suggested. A small ($\leq 10\Omega$) resistor placed between C_{IN} (C1) and the V_{IN} pin provides further isolation.

The selection of C_{OUT} is driven by the effective series resistance (ESR). Typically, once the ESR requirement is satisfied, the capacitance is adequate for filtering. The output ripple (ΔV_{OUT}) is approximated by:

$$\Delta V_{OUT} \approx \Delta I_L \left(ESR + \frac{1}{8 \cdot f \cdot C_{OUT}} \right)$$

where f is the operating frequency, C_{OUT} is the output capacitance and ΔI_L is the ripple current in the inductor. The output ripple is highest at maximum input voltage since ΔI_L increases with input voltage.

Setting Buck Output Voltage

The LTC7813 output voltage for the buck controller is set by an external feedback resistor divider carefully placed across the output, as shown in Figure 3. The regulated output voltage is determined by:

$$V_{OUT(BUCK)} = 0.8V \left(1 + \frac{R_B}{R_A} \right)$$

To improve the frequency response, a feedforward capacitor, C_{FF} , may be used. Great care should be taken to route the V_{FB} line away from noise sources, such as the inductor or the SW line.

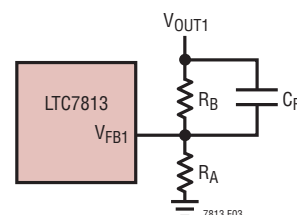

Figure 3. Setting Buck Output Voltage

Setting Boost Output Voltage (VPRG2 Pin)

Through control of the VPRG2 pin, the boost controller output voltage can be set by an external feedback resistor divider or programmed to a fixed 10V or 12V output.

Grounding VPRG2 allows the boost output voltage to be set by an external feedback resistor divider placed across the output, as shown in Figure 4a. The regulated output voltage is determined by:

$$V_{OUT(BOOST)} = 1.2V \left(1 + \frac{R_B}{R_A} \right)$$

Tying the VPRG2 to $INTV_{CC}$ or floating it configures the boost controller in fixed output voltage mode. Figure 4b shows how the V_{FB2} pin is used to sense the output

APPLICATIONS INFORMATION

voltage in this mode. Tying VPRG2 to INTV_{CC} programs the boost output to 12V, whereas floating VPRG2 programs the output to 10V.

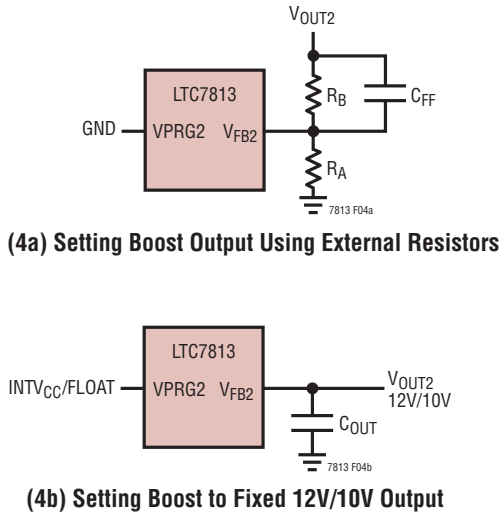

Figure 4. Setting Boost Output Voltage

RUN Pins

The LTC7813 is enabled using the RUN1 and RUN2 pins. The RUN pins have a rising threshold of 1.275V with 75mV of hysteresis. Pulling a RUN pin below 1.2V shuts down the main control loop for that channel. Pulling all three RUN pins below 0.7V disables the controllers and most internal circuits, including the DRV_{CC} and INTV_{CC} LDOs. In this state, the LTC7813 draws only 3.6μA of quiescent current.

Releasing a RUN pin allows a small 150nA internal current to pull up the pin to enable that controller. Because of condensation or other small board leakage pulling the pin down, it is recommended the RUN pins be externally pulled up or driven directly by logic. Each RUN pin can tolerate up to 65V (absolute maximum), so it can be conveniently tied to V_{BIAS} in always-on applications where one or more controllers are enabled continuously and never shut down.

The RUN pins can be implemented as a UVLO by connecting them to the output of an external resistor divider network off V_{BIAS}, as shown in Figure 5.

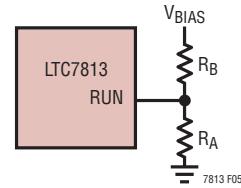

Figure 5. Using the RUN Pins as a UVLO

The rising and falling UVLO thresholds are calculated using the RUN pin thresholds and pull-up current:

$$V_{UVLO(RISING)} = 1.275V \left(1 + \frac{R_B}{R_A} \right) - 150nA \cdot R_B$$

$$V_{UVLO(FALLING)} = 1.20V \left(1 + \frac{R_B}{R_A} \right) - 150nA \cdot R_B$$

Tracking and Soft-Start (TRACK/SS1 and SS2 Pins)

The start-up of each V_{OUT} is controlled by the voltage on the TRACK/SS pin (TRACK/SS1 for channel 1, SS2 for channel 2). When the voltage on the TRACK/SS pin is less than the internal 0.8V reference (1.2V reference for the boost channel), the LTC7813 regulates the V_{FB} pin voltage to the voltage on the TRACK/SS pin instead of the internal reference. The TRACK/SS pin can be used to program an external soft-start function or to allow V_{OUT} to track another supply during start-up.

Soft-start is enabled by simply connecting a capacitor from the TRACK/SS pin to ground, as shown in Figure 6. An internal 10μA current source charges the capacitor, providing a linear ramping voltage at the TRACK/SS pin. The LTC7813 will regulate its feedback voltage (and hence V_{OUT}) according to the voltage on the TRACK/SS pin, allowing V_{OUT} to rise smoothly from 0V (V_{IN} for the boost)

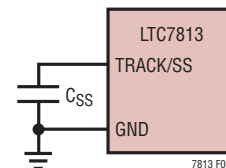

Figure 6. Using the TRACK/SS Pin to Program Soft-Start

APPLICATIONS INFORMATION

to its final regulated value. The total soft-start time will be approximately:

$$t_{SS_BUCK} = C_{SS} \cdot \frac{0.8V}{10\mu A}$$

$$t_{SS_BOOST} = C_{SS} \cdot \frac{1.2V}{10\mu A}$$

Alternatively, the TRACK/SS1 pin for the buck controller can be used to track another supply during start-up, as shown qualitatively in Figures 7a and 7b. To do this, a resistor divider should be connected from the master supply (V_X) to the TRACK/SS1 pin of the slave supply (V_{OUT}), as shown in Figure 8. During start-up V_{OUT} will track V_X according to the ratio set by the resistor divider:

$$\frac{V_X}{V_{OUT}} = \frac{R_A}{R_{TRACKA}} \cdot \frac{R_{TRACKA} + R_{TRACKB}}{R_A + R_B}$$

For coincident tracking ($V_{OUT} = V_X$ during start-up),

$$R_A = R_{TRACKA}$$

$$R_B = R_{TRACKB}$$

DRV_{CC} and INTV_{CC} Regulators (OPTI-DRIVE)

The LTC7813 features two separate internal P-channel low dropout linear regulators (LDO) that supply power at the DRV_{CC} pin from either the V_{BIAS} supply pin or the EXT_{V_{CC}} pin depending on the connections of the EXT_{V_{CC}} and DRVSET pins. A third P-channel LDO supplies power at the INTV_{CC} pin from the DRV_{CC} pin. DRV_{CC} powers the gate drivers whereas INTV_{CC} powers much of the LTC7813's internal circuitry. The V_{BIAS} LDO and the EXT_{V_{CC}} LDO regulate DRV_{CC} between 5V to 10V, depending on how the DRVSET pin is set. Each of these LDOs can supply a peak current of at least 50mA and must be bypassed to ground with a minimum of 4.7μF ceramic capacitor. Good bypassing is needed to supply the high transient currents required by the MOSFET gate drivers and to prevent interaction between the channels. The INTV_{CC} supply must be bypassed with a 0.1μF ceramic capacitor.

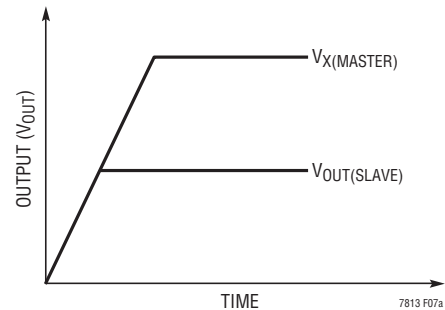

(7a) Coincident Tracking

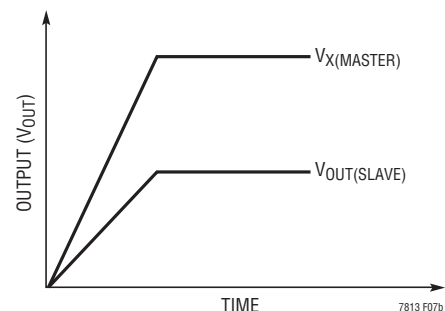

(7b) Ratiometric Tracking

Figure 7. Two Different Modes of Output Voltage Tracking

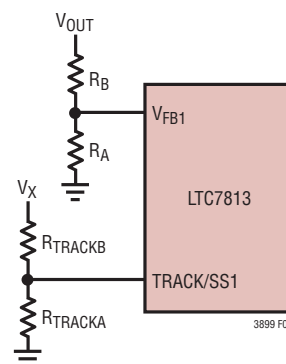

Figure 8. Using the TRACK/SS1 Pin for Tracking

APPLICATIONS INFORMATION

The DRVSET pin programs the DRV_{CC} supply voltage and the DRVUV pin selects different DRV_{CC} UVLO and EXTV_{CC} switchover threshold voltages. Table 1a summarizes the different DRVSET pin configurations along with the voltage settings that go with each configuration. Table 1b summarizes the different DRVUV pin settings. Tying the DRVSET pin to INTV_{CC} programs DRV_{CC} to 10V. Tying the DRVSET pin to GND programs DRV_{CC} to 6V. By placing a 50k to 100k resistor between DRVSET and GND the DRV_{CC} voltage can be programmed between 5V to 10V, as shown in Figure 8.

Table 1a

DRVSET PIN	DRV _{CC} VOLTAGE
GND	6V
INTV _{CC}	10V
Resistor to GND 50k to 100k	5V to 10V

Table 1b

DRVUV PIN	DRV _{CC} UVLO RISING / FALLING THRESHOLDS	EXTV _{CC} SWITCHOVER RISING/FALLING THRESHOLD
0V	4.0V / 3.8V	4.7V / 4.45V
INTV _{CC}	7.5V / 6.7V	7.7V / 7.45V

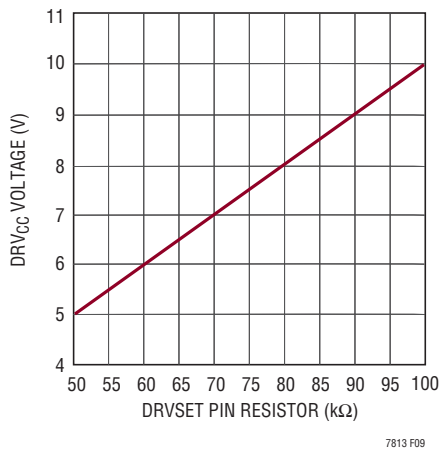

Figure 9. Relationship Between DRV_{CC} Voltage and Resistor Value at DRVSET Pin

High input voltage applications in which large MOSFETs are being driven at high frequencies may cause the maximum junction temperature rating for the LTC7813 to be exceeded. The DRV_{CC} current, which is dominated by the gate charge current, may be supplied by either the V_{BIAS}

LDO or the EXTV_{CC} LDO. When the voltage on the EXTV_{CC} pin is less than its switchover threshold (4.7V or 7.7V as determined by the DRVSET pin described above), the V_{BIAS} LDO is enabled. Power dissipation for the IC in this case is highest and is equal to V_{BIAS} • I_{DRVCC}. The gate charge current is dependent on operating frequency as discussed in the Efficiency Considerations section. The junction temperature can be estimated by using the equations given in Note 2 of the Electrical Characteristics. For example, using the LTC7813 in the QFN package, the DRV_{CC} current is limited to less than 21mA from a 60V supply when not using the EXTV_{CC} supply at a 70°C ambient temperature:

$$T_J = 70^\circ\text{C} + (21\text{mA})(60\text{V})(44^\circ\text{C/W}) = 125^\circ\text{C}$$

To prevent the maximum junction temperature from being exceeded, the V_{BIAS} supply current must be checked while operating in forced continuous mode (PLLIN/MODE = INTV_{CC}) at maximum V_{BIAS}.

When the voltage applied to EXTV_{CC} rises above its switchover threshold, the V_{BIAS} LDO is turned off and the EXTV_{CC} LDO is enabled. The EXTV_{CC} LDO remains on as long as the voltage applied to EXTV_{CC} remains above the switchover threshold minus the comparator hysteresis. The EXTV_{CC} LDO attempts to regulate the DRV_{CC} voltage to the voltage as programmed by the DRVSET pin, so while EXTV_{CC} is less than this voltage, the LDO is in dropout and the DRV_{CC} voltage is approximately equal to EXTV_{CC}. When EXTV_{CC} is greater than the programmed voltage, up to an absolute maximum of 14V, DRV_{CC} is regulated to the programmed voltage.

Using the EXTV_{CC} LDO allows the MOSFET driver and control power to be derived from the LTC7813's buck output (4.7V/7.7V ≤ V_{OUT} ≤ 14V) during normal operation and from the V_{BIAS} LDO when the output is out of regulation (e.g., start-up, short circuit). If more current is required through the EXTV_{CC} LDO than is specified, an external Schottky diode can be added between the EXTV_{CC} and DRV_{CC} pins. In this case, do not apply more than 10V to the EXTV_{CC} pin and make sure that EXTV_{CC} ≤ V_{BIAS}.

Significant efficiency and thermal gains can be realized by powering DRV_{CC} from the output, since the V_{IN} current resulting from the driver and control currents will be scaled by a factor of (Duty Cycle)/(Switcher Efficiency).

APPLICATIONS INFORMATION

For 5V to 14V regulator outputs, this means connecting the EXT_{V_{CC}} pin directly to V_{OUT}. Tying the EXT_{V_{CC}} pin to an 8.5V supply reduces the junction temperature in the previous example from 125°C to:

$$T_J = 70^\circ\text{C} + (21\text{mA})(8.5\text{V})(44^\circ\text{C}/\text{W}) = 78^\circ\text{C}$$

However, for 3.3V and other low voltage outputs, additional circuitry is required to derive DRV_{CC} power from the output.

The following list summarizes the four possible connections for EXT_{V_{CC}}:

1. EXT_{V_{CC}} grounded. This will cause DRV_{CC} to be powered from the internal V_{BIAS} regulator resulting in increased power dissipation in the LTC7813 at high input voltages.
2. EXT_{V_{CC}} connected directly to the output of the buck regulator. This is the normal connection for a 5V to 14V regulator and provides the highest efficiency.
3. EXT_{V_{CC}} connected to an external supply. If an external supply is available in the 5V to 14V range, it may be used to power EXT_{V_{CC}} providing it is compatible with the MOSFET gate drive requirements. Ensure that EXT_{V_{CC}} ≤ V_{BIAS}.
4. EXT_{V_{CC}} connected to an output-derived boost network off of the buck regulator. For 3.3V and other low voltage regulators, efficiency gains can still be realized by connecting EXT_{V_{CC}} to an output-derived voltage that has been boosted to greater than 4.7V/7.7V. Ensure that EXT_{V_{CC}} ≤ V_{BIAS}.

Topside MOSFET Driver Supply (C_B)

External bootstrap capacitors, C_B, connected to the BOOST pins supply the gate drive voltage for the topside MOSFET. The LTC7813 features an internal switch between DRV_{CC} and the BOOST pin for each controller. These internal switches eliminate the need for external bootstrap diodes between DRV_{CC} and BOOST. Capacitor C_B in the Functional Diagram is charged through this internal switch from DRV_{CC} when the SW pin is low. When the topside MOSFET is to be turned on, the driver places the C_B voltage across the gate-source of the MOSFET. This enhances the top MOSFET switch and turns it on. The switch node voltage, SW, rises to V_{IN} and the BOOST pin follows. With the topside MOSFET on, the boost voltage is above the input supply:

V_{BOOST} = V_{IN} + V_{DRVCC} (V_{BOOST} = V_{OUT} + V_{DRVCC} for the boost controller). The value of the boost capacitor, C_B, needs to be 100 times that of the total input capacitance of the topside MOSFET(s).

Fault Conditions: Buck Current Limit and Current Foldback

The LTC7813 includes current foldback for the buck channel to help limit load current when the output is shorted to ground. If the buck output voltage falls below 70% of its nominal output level, then the maximum sense voltage is progressively lowered from 100% to 40% of its maximum selected value. Under short-circuit conditions with very low duty cycles, the buck channel will begin cycle skipping in order to limit the short-circuit current. In this situation the bottom MOSFET will be dissipating most of the power but less than in normal operation. The short-circuit ripple current is determined by the minimum on-time, t_{ON(MIN)}, of the LTC7813 (~80ns), the input voltage and inductor value:

$$\Delta I_{L(SC)} = t_{ON(MIN)} \left(\frac{V_{IN}}{L} \right)$$

The resulting average short-circuit current is:

$$I_{SC} = 40\% \cdot I_{LIM(MAX)} - \frac{1}{2} \Delta I_{L(SC)}$$

Fault Conditions: Buck Overvoltage Protection (Crowbar)

The overvoltage crowbar is designed to blow a system input fuse when the output voltage of the buck regulator rises much higher than nominal levels. The crowbar causes huge currents to flow, that blow the fuse to protect against a shorted top MOSFET if the short occurs while the controller is operating.

A comparator monitors the buck output for overvoltage conditions. The comparator detects faults greater than 10% above the nominal output voltage. When this condition is sensed, the top MOSFET is turned off and the bottom MOSFET is turned on until the overvoltage condition is cleared. The bottom MOSFET remains on continuously for as long as the overvoltage condition persists; if V_{OUT} returns to a safe level, normal operation automatically resumes.

APPLICATIONS INFORMATION

A shorted top MOSFET will result in a high current condition which will open the system fuse. The switching regulator will regulate properly with a leaky top MOSFET by altering the duty cycle to accommodate the leakage.

Fault Conditions: Overtemperature Protection

At higher temperatures, or in cases where the internal power dissipation causes excessive self heating on chip (such as DRV_{CC} short to ground), the overtemperature shutdown circuitry will shut down the LTC7813. When the junction temperature exceeds approximately 175°C, the overtemperature circuitry disables the DRV_{CC} LDO, causing the DRV_{CC} supply to collapse and effectively shutting down the entire LTC7813 chip. Once the junction temperature drops back to the approximately 155°C, the DRV_{CC} LDO turns back on. Long-term overstress ($T_J > 125^\circ\text{C}$) should be avoided as it can degrade the performance or shorten the life of the part.

Phase-Locked Loop and Frequency Synchronization

The LTC7813 has an internal phase-locked loop (PLL) comprised of a phase frequency detector, a lowpass filter, and a voltage-controlled oscillator (VCO). This allows the turn-on of TG1 and BG2 to be locked to the rising edge of an external clock signal applied to the PLLIN/MODE pin. The phase detector is an edge sensitive digital type that provides zero degrees phase shift between the external and internal oscillators. This type of phase detector does not exhibit false lock to harmonics of the external clock.

If the external clock frequency is greater than the internal oscillator's frequency, f_{OSC} , then current is sourced continuously from the phase detector output, pulling up the VCO input. When the external clock frequency is less than f_{OSC} , current is sunk continuously, pulling down the VCO input.

If the external and internal frequencies are the same but exhibit a phase difference, the current sources turn on for an amount of time corresponding to the phase difference. The voltage at the VCO input is adjusted until the phase and frequency of the internal and external oscillators are identical. At the stable operating point, the phase detector output is high impedance and the internal filter capacitor, holds the voltage at the VCO input.

Note that the LTC7813 can only be synchronized to an external clock whose frequency is within range of the LTC7813's internal VCO, which is nominally 55kHz to 1MHz. This is guaranteed to be between 75kHz and 850kHz. Typically, the external clock (on the PLLIN/MODE pin) input high threshold is 1.6V, while the input low threshold is 1.1V. The LTC7813 is guaranteed to synchronize to an external clock that swings up to at least 2.5V and down to 0.5V or less.

Rapid phase locking can be achieved by using the FREQ pin to set a free-running frequency near the desired synchronization frequency. The VCO's input voltage is prebiased at a frequency corresponding to the frequency set by the FREQ pin. Once prebiased, the PLL only needs to adjust the frequency slightly to achieve phase lock and synchronization. Although it is not required that the free-running frequency be near the external clock frequency, doing so will prevent the operating frequency from passing through a large range of frequencies as the PLL locks.

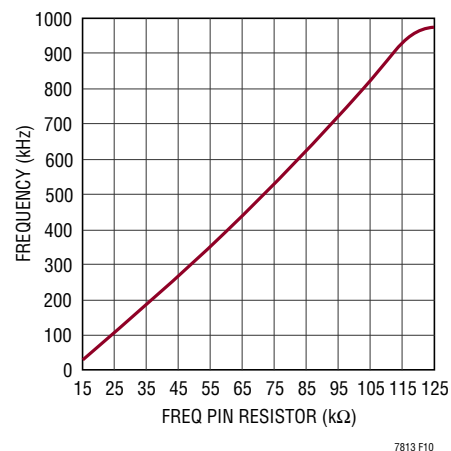

Figure 10. Relationship Between Oscillator Frequency and Resistor Value at the FREQ Pin

APPLICATIONS INFORMATION

Table 2 summarizes the different states in which the FREQ pin can be used.

Table 2

FREQ PIN	PLLIN/MODE PIN	FREQUENCY
0V	DC Voltage	350kHz
INTV _{CC}	DC Voltage	535kHz
Resistor to GND	DC Voltage	50kHz to 900kHz
Any of the Above	External Clock 75kHz to 850kHz	Phase Locked to External Clock

Minimum On-Time Considerations

Minimum on-time, $t_{ON(MIN)}$, is the smallest time duration that the LTC7813 is capable of turning on the top MOSFET (bottom MOSFET for the boost controller). It is determined by internal timing delays and the gate charge required to turn on the top MOSFET. Low duty cycle applications may approach this minimum on-time limit and care should be taken to ensure that:

$$t_{ON(MIN)_BUCK} < \frac{V_{OUT}}{V_{IN}(f)}$$

$$t_{ON(MIN)_BOOST} < \frac{V_{OUT} - V_{IN}}{V_{OUT}(f)}$$

If the duty cycle falls below what can be accommodated by the minimum on-time, the controller will begin to skip cycles. The output voltage will continue to be regulated, but the ripple voltage and current will increase.

The minimum on-time for the LTC7813 is approximately 80ns for the buck and 120ns for the boost. However, for the buck channels as the peak sense voltage decreases the minimum on-time gradually increases up to about 130ns. This is of particular concern in forced continuous applications with low ripple current at light loads. If the duty cycle drops below the minimum on-time limit in this situation, a significant amount of cycle skipping can occur with correspondingly larger current and voltage ripple.

Efficiency Considerations

The percent efficiency of a switching regulator is equal to the output power divided by the input power times 100%. It is often useful to analyze individual losses to determine what is limiting the efficiency and which change would

produce the most improvement. Percent efficiency can be expressed as:

$$\% \text{Efficiency} = 100\% - (L1 + L2 + L3 + \dots)$$

where L1, L2, etc. are the individual losses as a percentage of input power.

Although all dissipative elements in the circuit produce losses, four main sources usually account for most of the losses in LTC7813 circuits: 1) IC V_{BIAS} current, 2) DRV_{CC} regulator current, 3) I^2R losses, 4) Topside MOSFET transition losses.

1. The V_{BIAS} current is the DC supply current given in the Electrical Characteristics table, which excludes MOSFET driver and control currents. V_{BIAS} current typically results in a small (<0.1%) loss.
2. DRV_{CC} current is the sum of the MOSFET driver and control currents. The MOSFET driver current results from switching the gate capacitance of the power MOSFETs. Each time a MOSFET gate is switched from low to high to low again, a packet of charge, dQ , moves from DRV_{CC} to ground. The resulting dQ/dt is a current out of DRV_{CC} that is typically much larger than the control circuit current. In continuous mode, $I_{GATECHG} = f(Q_T + Q_B)$, where Q_T and Q_B are the gate charges of the topside and bottom side MOSFETs.

Supplying DRV_{CC} from an output-derived source power through EXT_V_{CC} will scale the V_{IN} current required for the driver and control circuits by a factor of (Duty Cycle)/(Efficiency). For example, in a 20V to 5V application, 10mA of DRV_{CC} current results in approximately 2.5mA of V_{IN} current. This reduces the midcurrent loss from 10% or more (if the driver was powered directly from V_{IN}) to only a few percent.

3. I^2R losses are predicted from the DC resistances of the fuse (if used), MOSFET, inductor, current sense resistor and input and output capacitor ESR. In continuous mode the average output current flows through L and R_{SENSE} , but is chopped between the topside MOSFET and the synchronous MOSFET. If the two MOSFETs have approximately the same $R_{DS(ON)}$, then the resistance of one MOSFET can simply be summed with the resistances of L, R_{SENSE} and ESR to obtain I^2R losses.

APPLICATIONS INFORMATION

For example, if each $R_{DS(ON)} = 30\text{m}\Omega$, $R_L = 50\text{m}\Omega$, $R_{SENSE} = 10\text{m}\Omega$ and $R_{ESR} = 40\text{m}\Omega$ (sum of both input and output capacitance losses), then the total resistance is $130\text{m}\Omega$. This results in losses ranging from 3% to 13% as the output current increases from 1A to 5A for a 5V output, or a 4% to 20% loss for a 3.3V output. Efficiency varies as the inverse square of V_{OUT} for the same external components and output power level. The combined effects of increasingly lower output voltages and higher currents required by high performance digital systems is not doubling but quadrupling the importance of loss terms in the switching regulator system!

- Transition losses apply only to the top MOSFET(s) (bottom MOSFET for the boost), and become significant only when operating at high input (output for the boost) voltages (typically 20V or greater). Transition losses can be estimated from:

$$\text{Transition Loss} = (1.7) \cdot V_{IN}^2 \cdot I_{O(MAX)} \cdot C_{RSS} \cdot f$$

Other hidden losses such as copper trace and internal battery resistances can account for an additional 5% to 10% efficiency degradation in portable systems. It is very important to include these system level losses during the design phase. The internal battery and fuse resistance losses can be minimized by making sure that C_{IN} has adequate charge storage and very low ESR at the switching frequency. A 25W supply will typically require a minimum of $20\mu\text{F}$ to $40\mu\text{F}$ of capacitance having a maximum of $20\text{m}\Omega$ to $50\text{m}\Omega$ of ESR. Other losses including Schottky conduction losses during dead-time and inductor core losses generally account for less than 2% total additional loss.

Checking Transient Response

The regulator loop response can be checked by looking at the load current transient response. Switching regulators take several cycles to respond to a step in DC (resistive) load current. When a load step occurs, V_{OUT} shifts by an amount equal to $\Delta I_{LOAD(ESR)}$, where ESR is the effective series resistance of C_{OUT} . ΔI_{LOAD} also begins to charge or discharge C_{OUT} generating the feedback error signal that forces the regulator to adapt to the current change and return V_{OUT} to its steady-state value. During this recovery time V_{OUT} can be monitored for excessive overshoot

or ringing, which would indicate a stability problem. OPTI-LOOP compensation allows the transient response to be optimized over a wide range of output capacitance and ESR values. The availability of the ITH pin not only allows optimization of control loop behavior, but it also provides a DC-coupled and AC-filtered closed-loop response test point. The DC step, rise time and settling at this test point truly reflects the closed-loop response. Assuming a predominantly second order system, phase margin and/or damping factor can be estimated using the percentage of overshoot seen at this pin. The bandwidth can also be estimated by examining the rise time at the pin. The ITH external components shown in Figure 12 circuit will provide an adequate starting point for most applications.

The ITH series R_C - C_C filter sets the dominant pole-zero loop compensation. The values can be modified slightly to optimize transient response once the final PC layout is done and the particular output capacitor type and value have been determined. The output capacitors need to be selected because the various types and values determine the loop gain and phase. An output current pulse of 20% to 80% of full-load current having a rise time of $1\mu\text{s}$ to $10\mu\text{s}$ will produce output voltage and ITH pin waveforms that will give a sense of the overall loop stability without breaking the feedback loop.

Placing a power MOSFET directly across the output capacitor and driving the gate with an appropriate signal generator is a practical way to produce a realistic load step condition. The initial output voltage step resulting from the step change in output current may not be within the bandwidth of the feedback loop, so this signal cannot be used to determine phase margin. This is why it is better to look at the ITH pin signal which is in the feedback loop and is the filtered and compensated control loop response.

The gain of the loop will be increased by increasing R_C and the bandwidth of the loop will be increased by decreasing C_C . If R_C is increased by the same factor that C_C is decreased, the zero frequency will be kept the same, thereby keeping the phase shift the same in the most critical frequency range of the feedback loop. The output voltage settling behavior is related to the stability of the closed-loop system and will demonstrate the actual overall supply performance.

APPLICATIONS INFORMATION

A second, more severe transient is caused by switching in loads with large ($>1\mu\text{F}$) supply bypass capacitors. The discharged bypass capacitors are effectively put in parallel with C_{OUT} , causing a rapid drop in V_{OUT} . No regulator can alter its delivery of current quickly enough to prevent this sudden step change in output voltage if the load switch resistance is low and it is driven quickly. If the ratio of C_{LOAD} to C_{OUT} is greater than 1:50, the switch rise-time should be controlled so that the load rise-time is limited to approximately $25 \cdot C_{\text{LOAD}}$. Thus a $10\mu\text{F}$ capacitor would require a $250\mu\text{s}$ rise time, limiting the charging current to about 200mA .

Buck Design Example

As a design example for the buck channel, assume $V_{\text{IN}} = 12\text{V}$ (nominal), $V_{\text{IN}} = 22\text{V}$ (maximum), $V_{\text{OUT}} = 3.3\text{V}$, $I_{\text{MAX}} = 5\text{A}$, $V_{\text{SENSE(MAX)}} = 75\text{mV}$ and $f = 350\text{kHz}$. The inductance value is chosen first based on a 30% ripple current assumption. The highest value of ripple current occurs at the maximum input voltage. Tie the FREQ pin to GND , generating 350kHz operation. The minimum inductance for 30% ripple current is:

$$\Delta I_L = \frac{V_{\text{OUT}}}{(f)(L)} \left(1 - \frac{V_{\text{OUT}}}{V_{\text{IN(NOM)}}} \right)$$

A $4.7\mu\text{H}$ inductor will produce 29% ripple current. The peak inductor current will be the maximum DC value plus one half the ripple current, or 5.73A . Increasing the ripple current will also help ensure that the minimum on-time of 80ns is not violated. The minimum on-time occurs at maximum V_{IN} :

$$t_{\text{ON(MIN)}} = \frac{V_{\text{OUT}}}{V_{\text{IN(MAX)}}(f)} = \frac{3.3\text{V}}{22\text{V}(350\text{kHz})} = 429\text{ns}$$

The equivalent R_{SENSE} resistor value can be calculated by using the minimum value for the maximum current sense threshold (65mV):

$$R_{\text{SENSE}} \leq \frac{65\text{mV}}{5.73\text{A}} \approx 0.01\Omega$$

Choosing 1% resistors: $R_A = 25\text{k}$ and $R_B = 78.7\text{k}$ yields an output voltage of 3.32V .

The power dissipation on the topside MOSFET can be easily estimated. Choosing a Fairchild FDS6982S dual MOSFET results in: $R_{\text{DS(ON)}} = 0.035\Omega/0.022\Omega$, $C_{\text{MILLER}} = 215\text{pF}$. At maximum input voltage with $T(\text{estimated}) = 50^\circ\text{C}$:

$$P_{\text{MAIN}} = \frac{3.3\text{V}}{22\text{V}}(5\text{A})^2 [1 + (0.005)(50^\circ\text{C} - 25^\circ\text{C})] \\ (0.035\Omega) + (22\text{V})^2 \frac{5\text{A}}{2} (2.5\Omega)(215\text{pF}) \cdot \\ \left[\frac{1}{6\text{V} - 2.3\text{V}} + \frac{1}{2.3\text{V}} \right] (350\text{kHz}) = 308\text{mW}$$

A short-circuit to ground will result in a folded back current of:

$$I_{\text{SC}} = \frac{34\text{mV}}{0.01\Omega} - \frac{1}{2} \left(\frac{80\text{ns}(22\text{V})}{4.7\mu\text{H}} \right) = 3.21\text{A}$$

with a typical value of $R_{\text{DS(ON)}}$ and $\delta = (0.005/^\circ\text{C})(25^\circ\text{C}) = 0.125$. The resulting power dissipated in the bottom MOSFET is:

$$P_{\text{SYNC}} = (3.21\text{A})^2 (1.125) (0.022\Omega) = 255\text{mW}$$

which is less than under full-load conditions.

C_{IN} is chosen for an RMS current rating of at least 3A at temperature assuming only this channel is on. C_{OUT} is chosen with an ESR of 0.02Ω for low output ripple. The output ripple in continuous mode will be highest at the maximum input voltage. The output voltage ripple due to ESR is approximately:

$$V_{\text{O(RIPPLE)}} = R_{\text{ESR}} (\Delta I_L) = 0.02\Omega (1.45\text{A}) = 29\text{mV}_{\text{P-P}}$$

PC Board Layout Checklist

When laying out the printed circuit board, the following checklist should be used to ensure proper operation of the IC. Figure 11 illustrates the current waveforms present in the various branches of the synchronous boost and buck regulators operating in the continuous mode. Check the following in your layout:

1. Are the signal and power grounds kept separate? The combined IC signal ground pin and the ground return of C_{DRVCC} must return to the combined $C_{\text{OUT}}(-)$ terminals. The path formed by the top N-channel MOSFET, bottom N-channel MOSFET, and the C_{IN} capacitor should have

APPLICATIONS INFORMATION

short leads and PC trace lengths. The output capacitor (–) terminals should be connected as close as possible to the (–) terminals of the input capacitor by placing the capacitors next to each other and away from the MOSFET loop described above.

- Does the LTC7813 V_{FB} pins' resistive divider connect to the (+) terminal of C_{OUT} ? The resistive divider must be connected between the (+) terminal of C_{OUT} and signal ground. The feedback resistor connections should not be along the high current input feeds from the input capacitor(s).
- Are the $SENSE^-$ and $SENSE^+$ leads routed together with minimum PC trace spacing? The filter capacitor between $SENSE^+$ and $SENSE^-$ should be as close as possible to the IC. Ensure accurate current sensing with Kelvin connections at the SENSE resistor.
- Is the DRV_{CC} and decoupling capacitor connected close to the IC, between the DRV_{CC} and the ground pin? This capacitor carries the MOSFET drivers' current peaks.
- Keep the switching nodes (SW1, SW2), top gate (TG1, TG2), and boost nodes (BOOST1, BOOST2) away from sensitive small-signal nodes, especially from the other channel's voltage and current sensing feedback pins. All of these nodes have very large and fast moving signals and therefore should be kept on the output side of the LTC7813 and occupy minimum PC trace area.
- Use a modified star ground technique: a low impedance, large copper area central grounding point on the same side of the PC board as the input and output capacitors with tie-ins for the bottom of the DRV_{CC} decoupling capacitor, the bottom of the voltage feedback resistive divider and the GND pin of the IC.

PC Board Layout Debugging

Start with one controller at a time. It is helpful to use a DC-50MHz current probe to monitor the current in the inductor while testing the circuit. Monitor the output switching node (SW pin) to synchronize the oscilloscope to the internal oscillator and probe the actual output voltage as well. Check for proper performance over the operating voltage and current range expected in the application. The frequency of operation should be maintained over the input voltage range down to dropout and until the output load

drops below the low current operation threshold—typically 25% of the maximum designed current level in Burst Mode operation.

The duty cycle percentage should be maintained from cycle to cycle in a well-designed, low noise PCB implementation. Variation in the duty cycle at a subharmonic rate can suggest noise pickup at the current or voltage sensing inputs or inadequate loop compensation. Overcompensation of the loop can be used to tame a poor PC layout if regulator bandwidth optimization is not required. Only after each controller is checked for its individual performance should both should multiple controllers be turned on at the same time.

Reduce V_{IN} from its nominal level to verify operation of the regulator in dropout. Check the operation of the undervoltage lockout circuit by further lowering V_{IN} while monitoring the outputs to verify operation.

Investigate whether any problems exist only at higher output currents or only at higher input voltages. If problems coincide with high input voltages and low output currents, look for capacitive coupling between the BOOST, SW, TG, and possibly BG connections and the sensitive voltage and current pins. The capacitor placed across the current sensing pins needs to be placed immediately adjacent to the pins of the IC. This capacitor helps to minimize the effects of differential noise injection due to high frequency capacitive coupling. If problems are encountered with high current output loading at lower input voltages, look for inductive coupling between C_{IN} , Schottky and the top MOSFET components to the sensitive current and voltage sensing traces. In addition, investigate common ground path voltage pickup between these components and the GND pin of the IC.

An embarrassing problem, which can be missed in an otherwise properly working switching regulator, results when the current sensing leads are hooked up backwards. The output voltage under this improper hookup will still be maintained but the advantages of current mode control will not be realized. Compensation of the voltage loop will be much more sensitive to component selection. This behavior can be investigated by temporarily shorting out the current sensing resistor—don't worry, the regulator will still maintain control of the output voltage.

APPLICATIONS INFORMATION

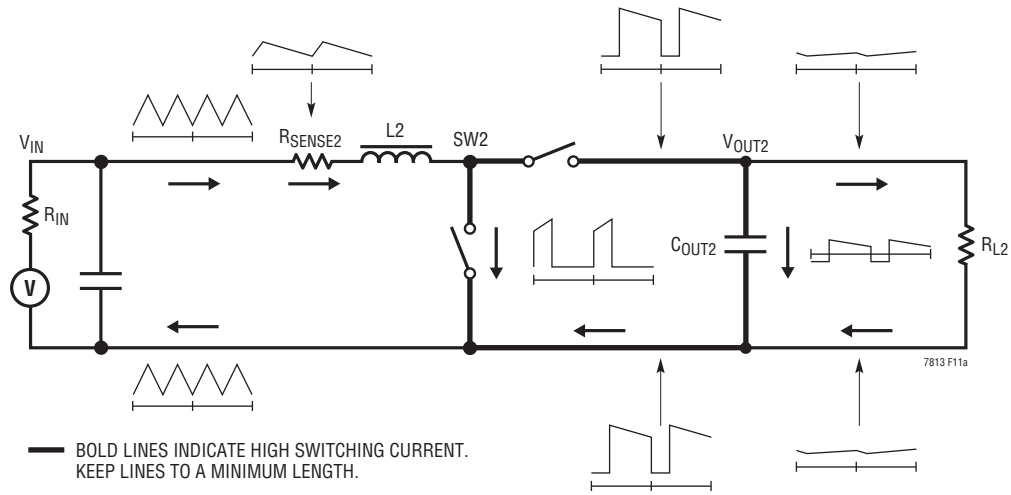

(a) Boost Regulator

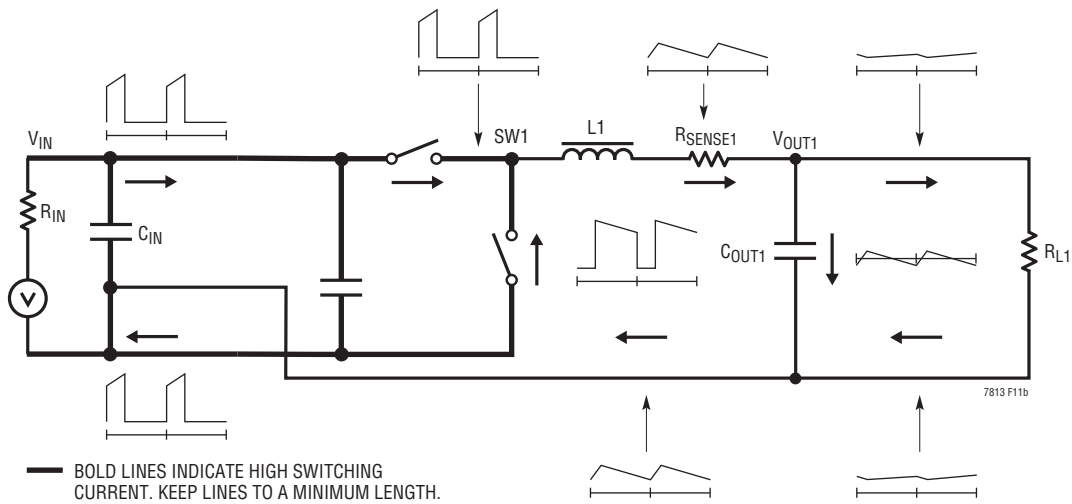

(b) Buck Regulator

Figure 11. Branch Current Waveforms

APPLICATIONS INFORMATION

Compensation and V_{MID} Capacitance in a Cascaded Boost+Buck Regulator

When using the LTC7813 as a cascaded Boost+Buck regulator, the boost and buck regulator control loops are compensated individually. While this may seem more complicated, this is actually advantageous, as the inherently fast buck loop can be designed to handle the output load transient, while the boost loop is less important and can be slower.

The amount of capacitance needed on the intermediate V_{MID} node (boost output) and the buck output V_{OUT} depends on a number of factors, including the input voltage, output voltage, load current and the nature of any transients, and the mode of operation (Burst Mode operation, forced continuous mode, or pulse-skipping mode).

In general, the buck regulator should be designed to handle any output load transients and provide sufficiently low output ripple.

The boost regulator does not need to respond as fast, as the V_{MID} node can tolerate relatively high ripple and/or transient dips and therefore does not necessarily need a lot of capacitance. The V_{MID} node capacitance needs to be able to handle the input ripple current from the buck regulator. It also needs to be large enough that the boost regulator's voltage ripple and/or transient dips do not appear as significant input line steps to the buck regulator and feed through to the buck regulator's output.

The ripple on the V_{MID} node is higher in Burst Mode operation and pulse-skipping mode than in forced continuous mode, especially at light loads and/or if the input voltage is slightly below the regulated boost output (V_{MID}) voltage. Thus, Burst Mode operation and pulse-skipping mode generally require more V_{MID} capacitance than in forced continuous mode to maintain a similar amount of ripple.

The capacitance on the V_{MID} node can be all ceramic, or some combination of ceramic and polarized (tantalum, electrolytic, etc.) capacitors.

Choosing the V_{MID} Voltage in Cascaded Boost+Buck Regulator

There are many performance trade-offs when considering where to set the V_{MID} (boost output) regulation voltage (V_{MID_REG}) relative to the input voltage (V_{IN}) range and output (buck) regulation voltage (V_{OUT_REG}). These trade-offs include efficiency, quiescent current, switching noise/EMI, and voltage ripple.

Remember that V_{MID} will follow V_{IN} if $V_{IN} > V_{MID_REG}$ (see the Boost Controller Operation When $V_{IN} > V_{OUT}$ section in the Operation section). If $V_{IN} < V_{MID_REG}$, V_{MID} is regulated to V_{MID_REG} .

Consider as an example an automotive application that requires a regulated 12V output voltage generated from a vehicle battery. The battery spends most of its operating lifetime in a normal range of 10V to 16V, but may dip to as low as 2.5V during engine start and rise as high as 38V during high voltage transients.

We can designate the minimum normal operating voltage as $V_{IN_MIN_OP} = 10V$, and the maximum normal operating voltage as $V_{IN_MAX_OP} = 16V$. So what voltage should we choose for V_{MID_REG} ?

REGULATED OUTPUT VOLTAGE

In this example, note that we want a tightly regulated output ($V_{OUT_REG} = 12V$), which is within our normal operating range ($V_{IN_MIN_OP} < V_{OUT_REG} < V_{IN_MAX_OP}$). We want $V_{MID_REG} > V_{OUT_REG}$ to provide headroom for the buck regulator, but we have a choice of whether to set V_{MID_REG} above or below $V_{IN_MAX_OP}$.

OPTION A: $V_{MID_REG} > V_{OUT_REG}$ and $V_{MID_REG} > V_{IN_MAX_OP}$

In this option, we set $V_{MID_REG} > V_{IN_MAX_OP}$ (e.g., $V_{MID_REG} = 18V$). Both the boost regulator and the buck regulator are switching (at full, constant frequency if in forced continuous mode) over the full 10V to 16V normal operating range. Since the boost regulator is always switching, the efficiency is lower and the input ripple and EMI, while predictable and still low, are higher than other potential options.

APPLICATIONS INFORMATION

OPTION B: $V_{IN_MIN_OP} < V_{OUT_REG} < V_{MID_REG} < V_{IN_MAX_OP}$

This is similar to option A, but V_{MID_REG} is set within the normal operating input voltage range (e.g., $V_{MID_REG} = 14V$). When V_{IN} is well below V_{MID_REG} , this option is like Option A. But as V_{IN} approaches V_{MID_REG} , the boost controller will gradually begin skipping cycles (even in forced continuous mode) once it reaches minimum-on-time. If $V_{IN} > V_{MID_REG}$, then V_{MID} follows V_{IN} . In this region, OPTION B is more efficient than OPTION A since the boost is not switching. But this is at the expense of the cycle-skipping (non-constant frequency ripple) when V_{IN} is slightly below V_{MID_REG} .

LOOSELY REGULATED OUTPUT (Pass-Through Regulator)

In some applications, it is not critical that V_{OUT} be tightly regulated, but rather that it remains within a certain voltage range. Suppose, in our example, that it is only important that V_{OUT} be maintained within the normal battery operating voltage range of 10V to 16V. We can consider a third option:

OPTION C: $V_{MID_REG} = V_{IN_MIN_OP}$ and $V_{OUT_REG} = V_{IN_MAX_OP}$

Here we set $V_{MID_REG} = V_{IN_MIN_OP} = 10V$ and $V_{OUT_REG} = V_{IN_MAX_OP} = 16V$. So the boost regulator only boosts when $V_{IN} < 10V$ and the buck regulator only bucks when $V_{IN} > 16V$. When V_{IN} is between 10V to 16V, the circuit is in a “pass-through” or “wire” mode where there is very little switching. The boost regulator is not boosting (TG2 is on 100% in forced continuous mode) and the buck regulator is operating in dropout (with TG1 on at an effec-

tive 99% duty cycle). This makes the circuit very efficient, especially at heavy loads, with extremely low input and output ripple and EMI. Note that in this pass-through mode, the circuit does not benefit from the LTC7813’s ultralow quiescent current of 33 μ A in Burst Mode operation since the buck regulator does not go to sleep because $V_{OUT} < V_{OUT_REG} = 16V$.

REGULATED OUTPUT VOLTAGE BELOW NORMAL INPUT VOLTAGE OPERATING RANGE

In some applications, the desired output voltage might be less than the minimum normal operating voltage, but still higher than the worst case minimum input voltage. Consider our previous example, but instead suppose we want $V_{OUT} = 5V$. In this case, we can set our V_{MID_REG} such that:

OPTION D: $V_{IN_MIN_OP} > V_{MID_REG} > V_{OUT_REG}$

So we might set V_{MID_REG} just below 10V, so that the boost regulator never switches within the normal operating range and only needs to boost during the input voltage dips below 10V.

The buck controller always regulates the V_{OUT} to 5V, and the boost regulator’s inductor and V_{MID} capacitance create a filter that substantially reduces any input ripple and results in very little conducted EMI on the input.

Table 3 summarizes some of the performance trade-offs of these four potential ways to set the V_{MID} regulation voltage in an LTC7813 cascaded Boost+Buck regulator.

APPLICATIONS INFORMATION

Table 3. Summary of Trade-Offs in Choosing the V_{MID} Regulation Voltage in a Cascaded Boost+Buck Regulator

Option	A	B	C	D
	$V_{MID_REG} > V_{OUT_REG}$ and $V_{MID_REG} > V_{IN_MAX_OP}$	$V_{IN_MIN_OP} < V_{OUT_REG} <$ $V_{MID_REG} < V_{IN_MAX_OP}$	$V_{MID_REG} = V_{IN_MIN_OP}$ and $V_{OUT_REG} = V_{IN_MAX_OP}$ (Pass-Through/Wire Mode)	$V_{IN_MIN_OP} > V_{MID_REG} >$ V_{OUT_REG}
Example for Normal Input Operating Range of 10V to 16V ($V_{IN_MIN_OP} = 10V$, $V_{IN_MAX_OP} = 16V$) with a Full Range of 2.5V to 38V	$V_{MID_REG} = 18V$ $V_{OUT} = V_{OUT_REG} = 12V$	$V_{MID_REG} = 14V$ $V_{OUT} = V_{OUT_REG} = 12V$	$V_{MID_REG} = 10V$ $V_{OUT_REG} = 16V$ $V_{OUT} = 10V$ to 16V	$V_{MID_REG} = 10V$ $V_{OUT} = V_{OUT_REG} = 5V$
Boost Boosting in Normal Operating Range?	Yes, Over Full Range	Yes, When $V_{IN} < V_{MID_REG}$	No	No
Buck Bucking in Normal Operating Range?	Yes, Over Full Range	Yes, Over Full Range	No, in Dropout	Yes, Over Full Range
LTC7813 No Load Quiescent Current in Burst Mode	34 μ A	34 μ A	~3mA	34 μ A
Heavy Load Efficiency	Slightly Lower	High When Not Boosting; Slightly Lower When Boosting	Highest	High
Input Ripple	Low	Low When Boosting; Very Low When Not Boosting; Some Cycle-Skipping During Transition	Extremely Low	Very Low
Output Ripple	Low	Low	Extremely Low	Low
EMI in Normal Operating Range	Low	Very Low When Not Boosting; Low When Boosting	Extremely Low	Very Low
Example for Normal Operating Range: $V_{IN_MIN_OP} = 10V - V_{IN_MAX_OP} = 16V$	$V_{MID_REG} = 18V$ $V_{OUT} = V_{OUT_REG} = 12V$	$V_{MID_REG} = 14V$ $V_{OUT} = V_{OUT_REG} = 12V$	$V_{MID_REG} = 10V$ $V_{OUT_REG} = 16V$ $V_{OUT} = 10V$ to 16V	$V_{MID_REG} = 10V$ $V_{OUT} = V_{OUT_REG} = 5V$

TYPICAL APPLICATIONS

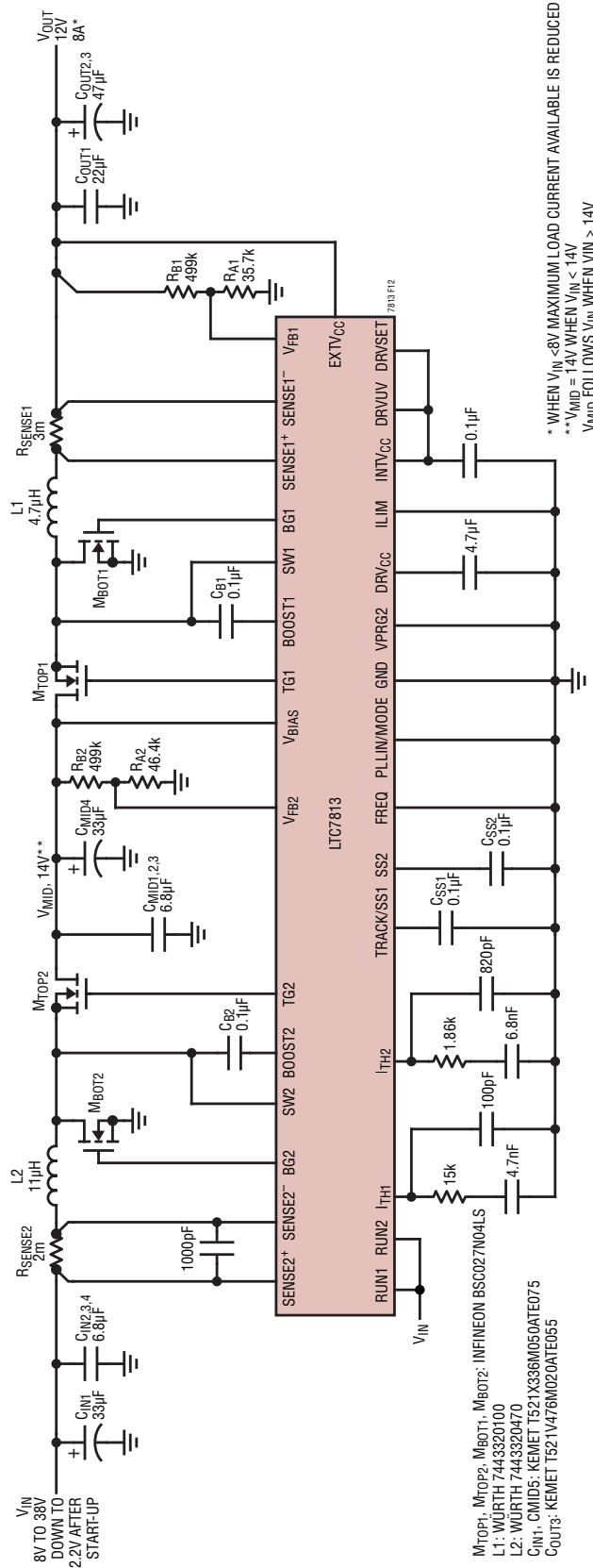

Figure 12. Wide Input Range to 12V/8A Low Iq Cascaded Boost+Buck Regulator ($V_{MID} = 14V$)

TYPICAL APPLICATIONS

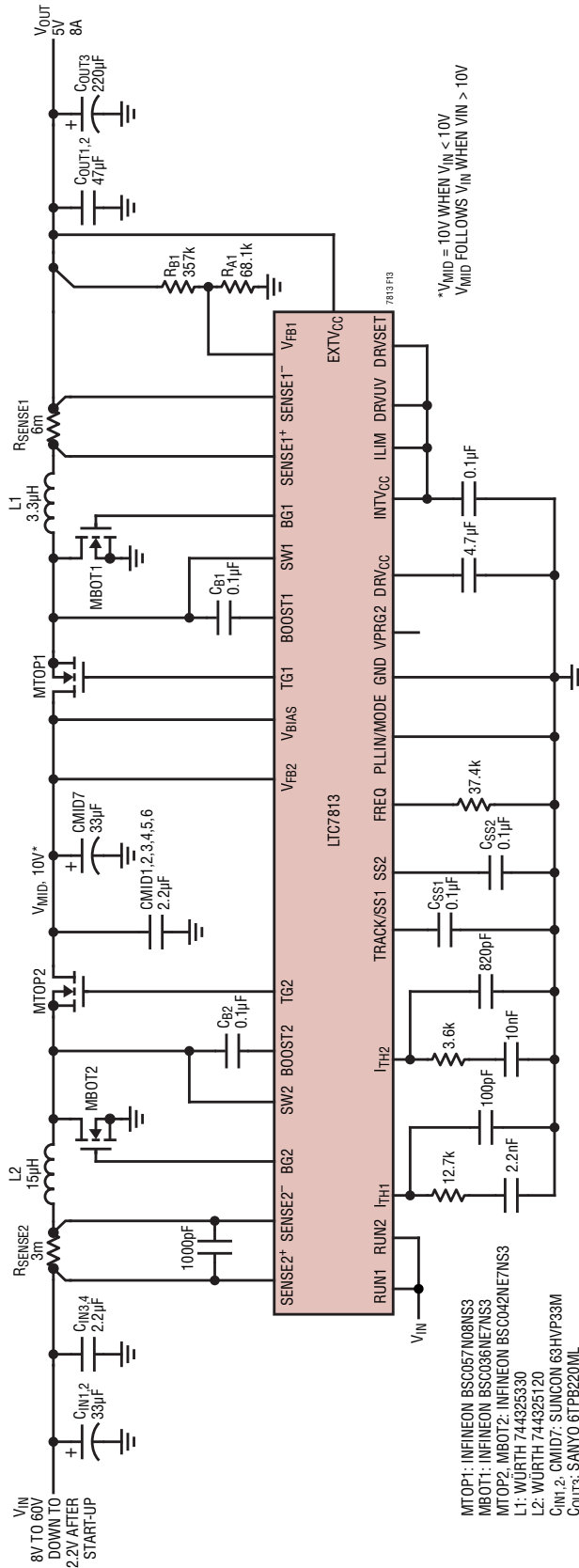
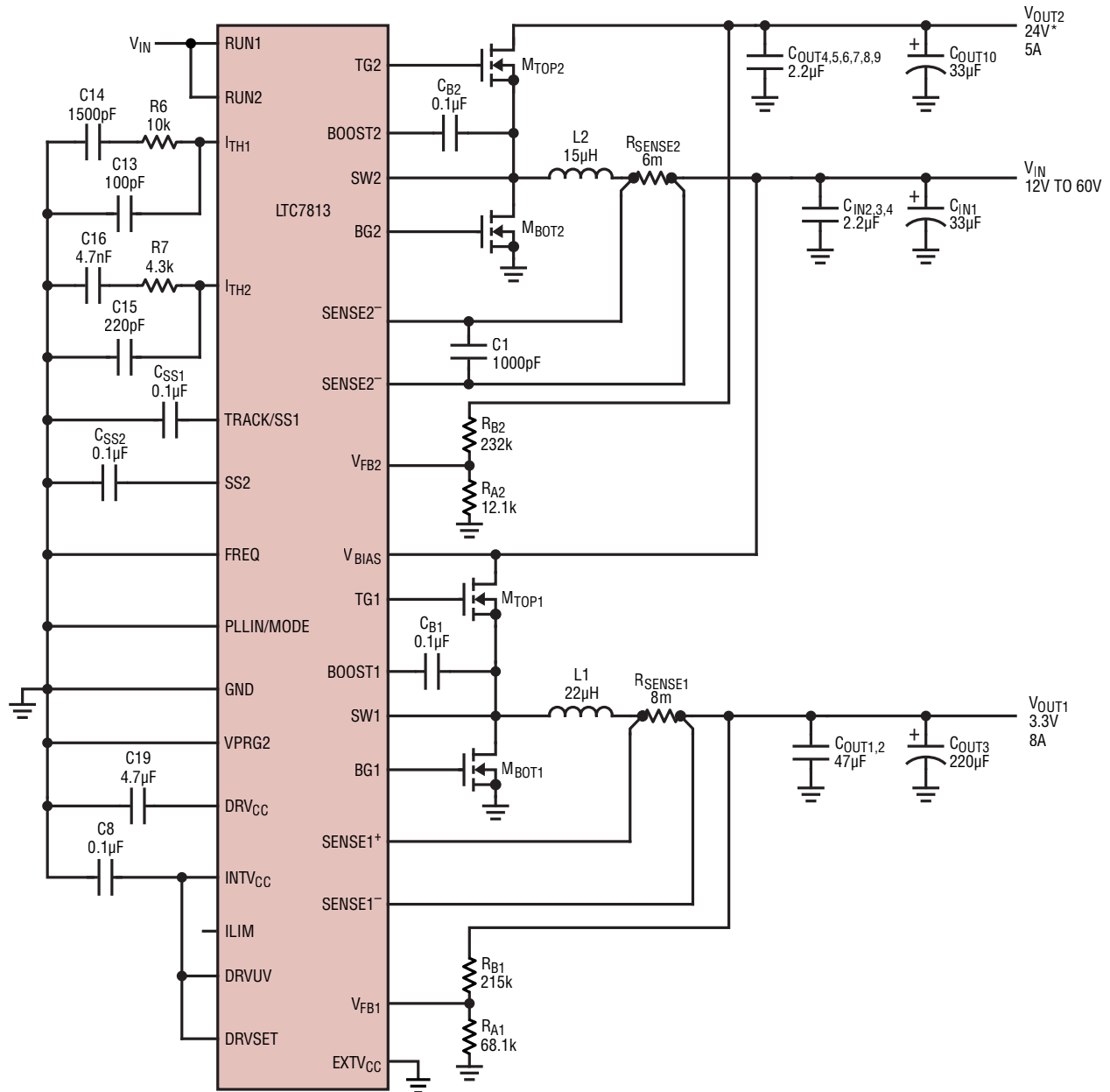

Figure 13. Wide Input Range to 5V/8A Low I_Q Cascaded Boost+Buck Regulator (V_{MID} Boosted to 10V)

TYPICAL APPLICATIONS

Figure 14. High Efficiency 12V to 60V V_{IN} to 24V/5A and 3.3V/8A DC/DC Regulator



- M_{TOP1}: INFINEON BSC057N08NS3
- M_{BOT1}: INFINEON BSC036NE7NS3
- M_{TOP2}, M_{BOT2}: INFINEON BSC042NE7NS3
- L1: WÜRTH 744325240
- L2: WÜRTH 7443551370
- C_{IN1}, C_{OUT1,0}: SUNCON 63HVP33M
- C_{OUT3}: SANYO 6TPB220ML

*V_{OUT2} = 24V WHEN V_{IN} < 24V
 V_{OUT2} FOLLOWS V_{IN} WHEN V_{IN} > 24V

7813 F14

TYPICAL APPLICATIONS

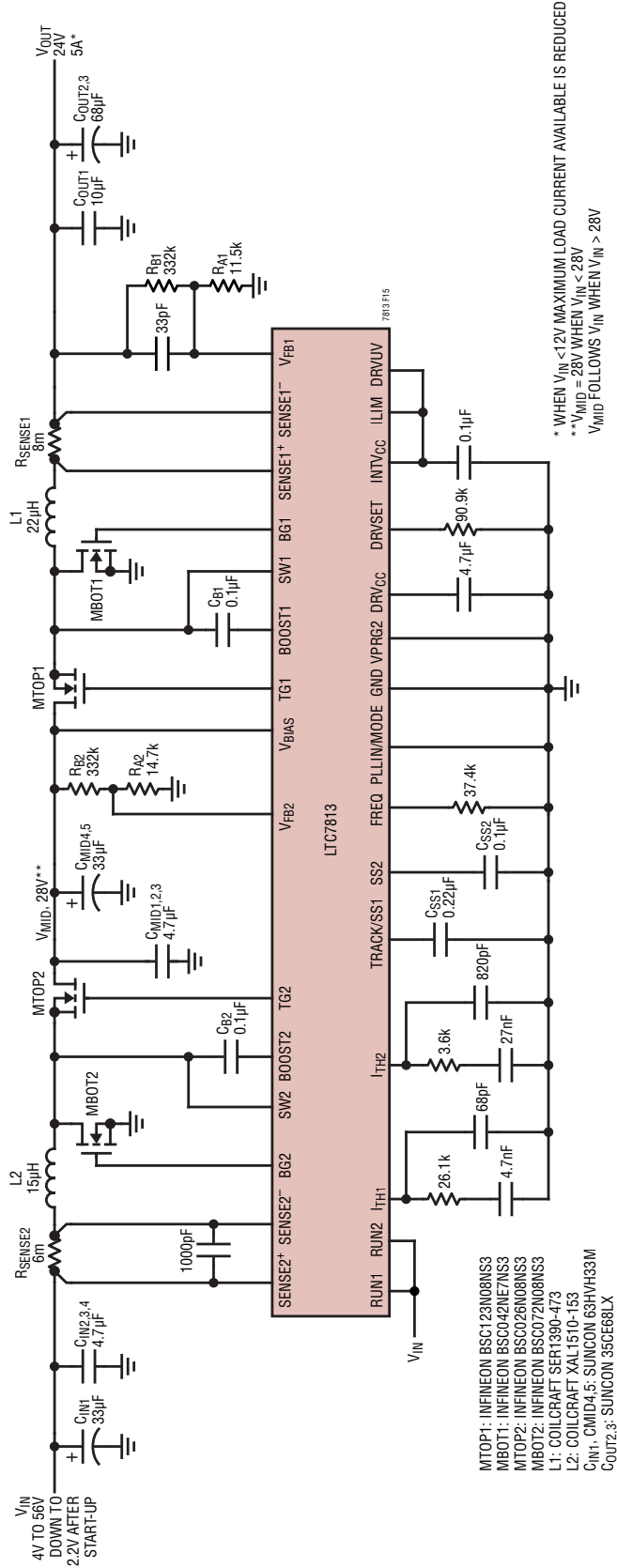
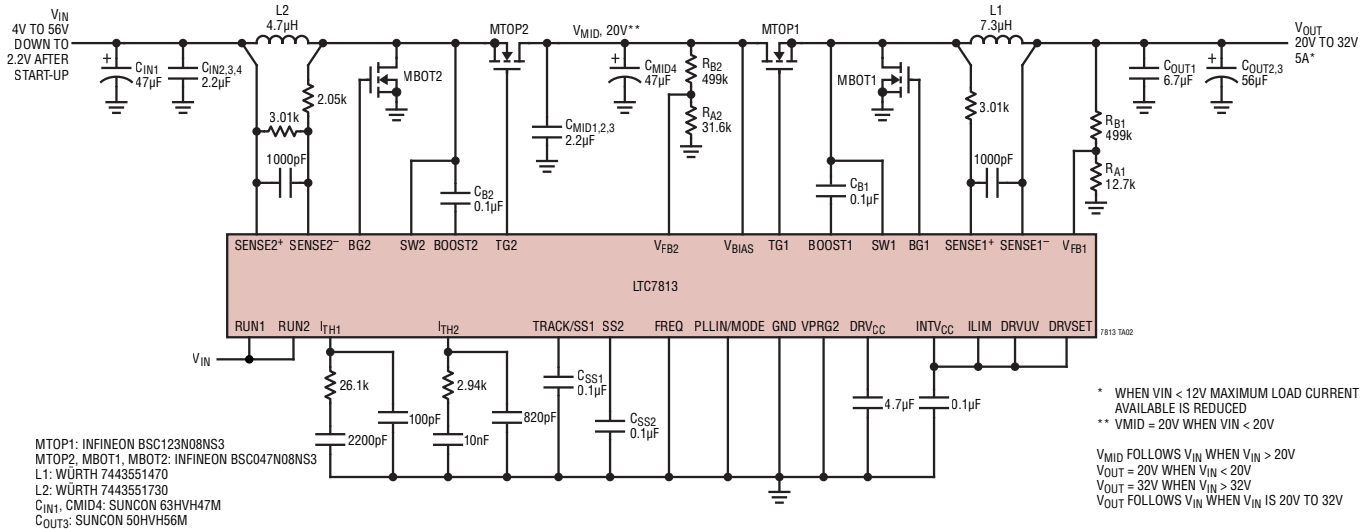

Figure 15. Wide Input Range to 24V/5A Low Iq Cascaded Boost + Buck Regulator ($V_{MID} = 28V$)

TYPICAL APPLICATION

Low EMI, Wide Input Range Pass-Through Cascaded Boost+Buck Regulator



RELATED PARTS

PART NUMBER	DESCRIPTION	COMMENTS
LTC7812	38V Synchronous Boost+Buck Controller with Low EMI and Low Input/Output Ripple	$4.5V$ (Down to $2.5V$ After Start-Up) $\leq V_{IN} \leq 38V$, Boost V_{OUT} Up to $60V$, $0.8V \leq$ Buck $V_{OUT} \leq 24V$, $I_Q = 33\mu A$, $5mm \times 5mm$ QFN-32
LTM[®]4609	$36V_{IN}$, $34V_{OUT}$, Buck-Boost μ Module Regulator	$4.5V \leq V_{IN} \leq 36V$, $0.8V \leq V_{OUT} \leq 34V$, Up to $4A$ $15mm \times 15mm$ LGA and BGA Packages
LTM8056	$58V_{IN}$, $48V_{OUT}$, Buck-Boost μ Module Regulator	$5V \leq V_{IN} \leq 58V$, $1.2V \leq V_{OUT} \leq 48V$, Up to $5.4A$ $15mm \times 15mm \times 4.92mm$ BGA Package
LTC3789	High Efficiency (Up to 98%) Synchronous 4-Switch Buck-Boost DC/DC Controller	$4V \leq V_{IN} \leq 38V$, $0.8V \leq V_{OUT} \leq 38V$, SSOP-28, $4mm \times 5mm$ QFN-28
LT[®]3790	$60V$ 4-Switch Synchronous Buck-Boost Controller	$4.7V \leq V_{IN} \leq 60V$, $1.2V \leq V_{OUT} \leq 60V$, TSSOP-38
LT8705	$80V V_{IN}$ and V_{OUT} Synchronous 4-Switch Buck-Boost DC/DC Controller	$2.8V \leq V_{IN} \leq 80V$, $1.3V \leq V_{OUT} \leq 80V$, Regulates V_{OUT} , I_{OUT} , V_{IN} , I_{IN} , $5mm \times 7mm$ QFN-38, Modified TSSOP Package for High Voltage
LTC3769	Low I_Q , $60V$ Synchronous Step-Up DC/DC Controller	$4.5V$ (Down to $2.3V$ After Start-Up) $\leq V_{IN} \leq 60V$, V_{OUT} Up to $60V$, $I_Q = 28\mu A$ PLL Fixed Frequency $50kHz$ to $900kHz$, $4mm \times 4mm$ QFN-24, TSSOP-20E
LTC3891	Low I_Q , $60V$ Synchronous Step-Down Controller with 99% Duty Cycle	PLL Fixed Frequency $50kHz$ to $900kHz$, $4V \leq V_{IN} \leq 60V$, $0.8V \leq V_{OUT} \leq 24V$, $I_Q = 50\mu A$
LTC3859AL	$38V$ Low I_Q Triple Output, Buck/Buck/Boost Synchronous Controller with $28\mu A$ Burst Mode I_Q	$4.5V$ (Down to $2.5V$ after Start-Up) $\leq V_{IN} \leq 38V$, V_{OUT} Up to $60V$, Buck V_{OUT} Range: $0.8V$ to $24V$
LTC3899	$60V$, Triple Output, Buck/Buck/Boost Synchronous Controller with $29\mu A$ Burst Mode I_Q	$4.5V$ (Down to $2.2V$ after Start-Up) $\leq V_{IN} \leq 60V$, V_{OUT} Up to $60V$, Buck V_{OUT} Range: $0.8V$ to $60V$
LTC3892/ LTC3892-1/ LTC3892-2	$60V$ Low I_Q , Dual, 2-Phase Synchronous Step-Down DC/DC Controller with $29\mu A$ Burst Mode I_Q	$4.5V \leq V_{IN} \leq 60V$, $0.8V \leq V_{OUT} \leq 0.99V_{IN}$, $5mm \times 5mm$ QFN-32, TSSOP-28 Packages

Looking for pricing, stock, or lifecycle information?

Click below to explore more details on WIN SOURCE:

 [View LTC7813EUH#PBF on WIN SOURCE](#)

 [Linear Technology](#) Information

Optimize Your Supply Chain with WIN SOURCE Solutions

-  Global Sourcing Solution
-  Obsolete Management
-  Cost Control Management
-  Shortage Management
-  Alternative Solution
-  Excess Inventory Management