



ON Semiconductor®

<http://onsemi.com>

LV56351HA

Bi-CMOS IC

1ch DC/DC boost converter

Overview

LV56351HA integrates 1ch DC/DC boost converter and 1ch LDO. It is suitable as the power supply for BS/CS antennas of LCD/PDP TV and BD recorders that require automatic recovery without IC destruction and malfunction when the output is short-circuited.

Functions

[DC/DC boost converter]

- Soft-start time: 2.8ms
- Frequency 425kHz operation
- Pulse by pulse over current limiter
- Short circuit protector (SCP)

[LDO]

- Over current limiter (Fold back)

[All]

- Under voltage lockout
- Thermal shutdown protector
- Power good

Specifications

Maximum Ratings at $T_a = 25^\circ\text{C}$

Parameter	Symbol	Conditions	Ratings	Unit
V_{CC} maximum supply voltage	$V_{CC\ max}$		-0.3 to 25	V
LDOIN maximum input voltage	$V_{LDOIN\ max}$		-0.3 to 30	V
SW maximum voltage	$V_{SW\ max}$		-0.3 to 30	V
Allowable power dissipation	$P_d\ max$	*1	1.45	W
Operating temperature	T_{opr}		-30 to +85	°C
Operating junction temperature	T_{jopr}		-30 to +125	°C
Storage temperature	T_{stg}		-40 to +150	°C
Allowable pin voltage	V_{CC}, EN		25	V
	SW, LDOIN, LDOOUT		30	V
	IN1, IN2, FB, SCP, PGOOD, DDCTL		6	V

*1 Mounted on a specified board : 32mm × 38mm × 1.6mm, glass epoxy, double side board.

Caution 1) Absolute maximum ratings represent the value which cannot be exceeded for any length of time.

Caution 2) Even when the device is used within the range of absolute maximum ratings, as a result of continuous usage under high temperature, high current, high voltage, or drastic temperature change, the reliability of the IC may be degraded. Please contact us for the further details.

Stresses exceeding Maximum Ratings may damage the device. Maximum Ratings are stress ratings only. Functional operation above the Recommended Operating Conditions is not implied. Extended exposure to stresses above the Recommended Operating Conditions may affect device reliability.

LV56351HA

Recommended Operating Conditions at Ta = 25°C

Parameter	Symbol	Conditions	Ratings	Unit
V _{CC} supply voltage	V _{CC}		8 to 23	V
LDOIN input voltage	V _{LDOIN}		8 to 28	V
SW voltage	V _{SW}		-0.3 to 28	V
EN voltage	V _{EN}		0 to 23	V

Electrical Characteristics at Ta = 25°C, V_{CC} = 12V, V_{EN}=2V, LDOIN=16V, LDOOUT=15V

Parameter	Symbol	Conditions	Ratings			Unit
			min	typ	max	
All						
Supply current1	I _{CC}	Switching is turned off		1.8	3.5	mA
Supply current2	I _{OFF}	EN = 0V			10	μA
Reference voltage	V _{REF}		1.2348	1.26	1.2852	V
Enable voltage	V _{EN}		2.0			V
Disable voltage	V _{DIS}				0.4	V
EN input current	I _{EN}	V _{EN} = 2.0V			10	μA
PGOOD threshold	V _{PG}	IN1 ≥ V _{REF} ×85% and IN2 ≥ V _{REF} ×85%		V _{REF} ×0.85		V
PGOOD sink current	I _{PG}	V _{PGOOD} = 0.5V		1.0		mA
PGOOD leak current	I _{PGLK}	V _{PGOOD} = 2V			10	μA
UVLO on voltage	V _{UVLO}			7.0		V
Thermal shutdown temperature	T _{TSD}	*2	130			°C
TSD hysteresis	T _{HYS}	*2		30		°C
DC/DC boost converter						
FB output voltage "Low"	FB _{Low}	IN1 = 2.0V, I _{FB} = -20μA (Sink)			0.2	V
FB output voltage "High"	FB _{High}	IN1 = 0.2V, I _{FB} = 20μA (Source)	1.8			V
Soft-start time	T _{SS}			2.8		ms
Oscillator frequency	F _{OSC}			425		kHz
Max on duty	D _{MAX}		78	85	92	%
SW on resistance	R _{ON}			0.7		Ω
SW peak current	I _{PK}		1.5	1.8		A
SCP source current	I _{SCP}			4.8		μA
SCP threshold	V _{SCP}			V _{REF}		V
DDCTL on voltage	V _{DDCTLON}	DC/DC Off	2.0			V
DDCTL off voltage	V _{DDCTLOFF}	DC/DC On			0.4	V
DDCTL input current	I _{DDCTL}	V _{DDCTL} = 2V			20	μA
LDO						
Maximum output current	I _{OMAX}		350	520	670	mA
Line regulation	R _{LN}	16V < LDOIN < 21V			20	mV
Load regulation	R _{LD}	10mA < I _O < 300mA			20	mV
Dropout voltage	V _{DROP}	I _O = 300mA		0.25	0.4	V
Short current	I _{SHORT}	LDOOUT = GND			100	mA

*2: Design guarantee value.

LV56351HA

Package Dimensions

unit : mm (typ)

3313A

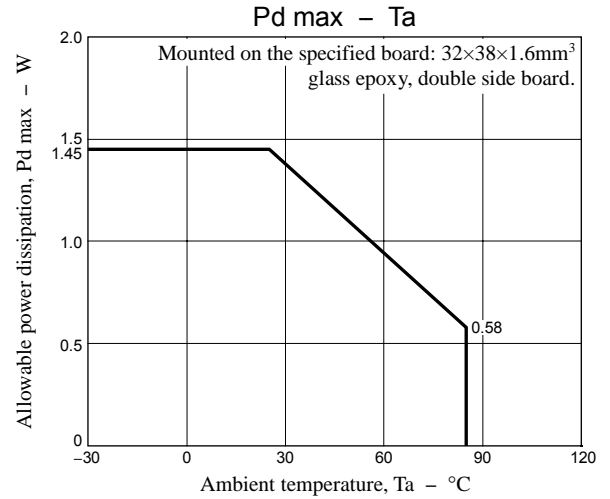
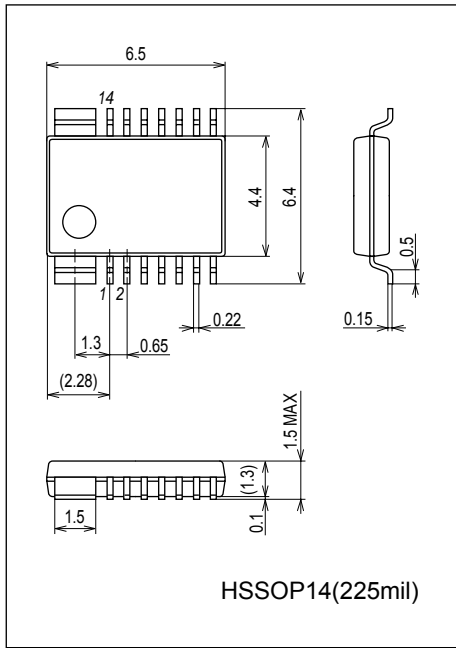

Specified board (32mm × 38mm × 1.6mm, glass epoxy, double side board)

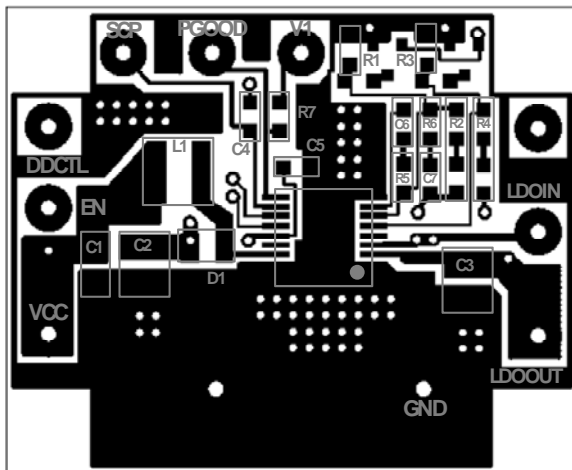

⟨⟨front⟩⟩

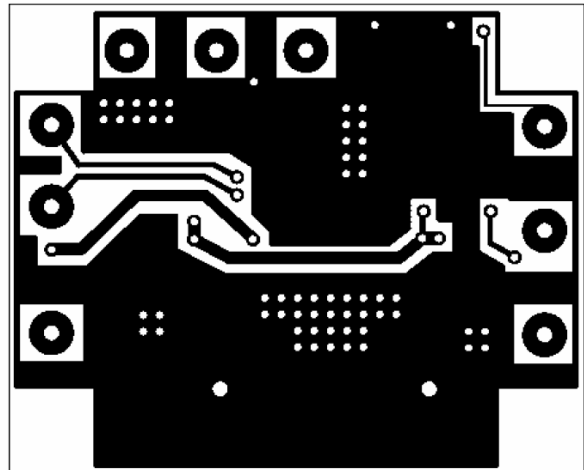

⟨⟨back⟩⟩

Pin assignment

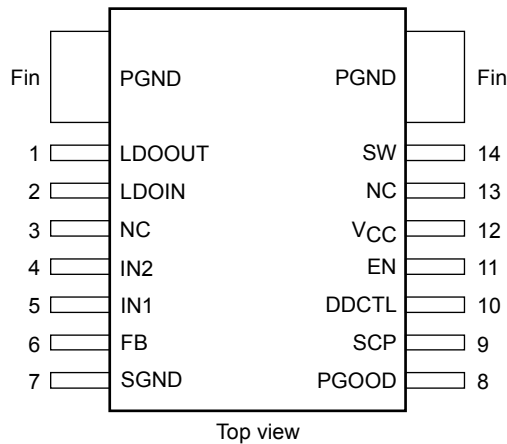

LV56351HA

Pin function

Pin No.	Pin name	Function	Equivalent circuit
1 2 7	LDOOUT LDOIN SGND	LDO output LDO input Signal ground (*3)	
4	IN2	LDO feedback input	
5	IN1	DC/DC error amplifier input	
6	FB	DC/DC error amplifier output	
8	PGOOD	Power good output	
9	SCP	DC/DC SCP capacitor connect pin for timer setting	
10	DDCTL	DC/DC on and off control	
11 12	EN VCC	Enable Power supply	

*3: When you use this IC, Please short-circuit all the pins of SGND and PGND on the IC mounting side.

Continued on next page.

LV56351HA

Continued from preceding page.

Pin No.	Pin name	Function	Equivalent circuit
14	SW	DC/DC open drain output	
Fin	PGND	Power ground (*3)	

*3: When you use this IC, Please short-circuit all the pins of SGND and PGND on the IC mounting side.

Function overview

(1) UVLO (Under Voltage Lockout)

UVLO stops outputs of both DC/DC and LDO to prevent malfunction when V_{CC} decreases. UVLO operates when V_{CC} falls below the UVLO voltage. This function is a non-latch-type, and recovers these outputs automatically when V_{CC} exceeds the UVLO voltage.

(2) Power good

Power good notifies that the output voltages of DC/DC and LDO are within the range of the setting voltage. The two output voltages are monitored through the voltage of IN1 and IN2. The output is judged to be “power good” when both outputs are 85% or higher compared to the setting voltages. If either IN1 or IN2 voltage falls below $V_{REF} \times 85\%$, PGOOD output becomes L \rightarrow H (No Good). When IN1 and IN2 voltages become $(V_{REF} \times 85\%) + 30\text{mV}$ or higher, PGOOD output becomes H \rightarrow L (Good). During soft start, the output is H (No Good).

⟨⟨Power good circuit diagram⟩⟩

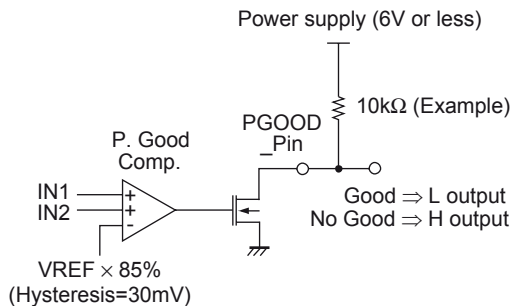

(3) Pulse-by-Pulse over current protection (P by P)

The P by P stops switch-on operation of a certain cycle by force when the current of power MOSFET reaches the maximum output peak current.

⟨⟨P by P circuit diagram⟩⟩

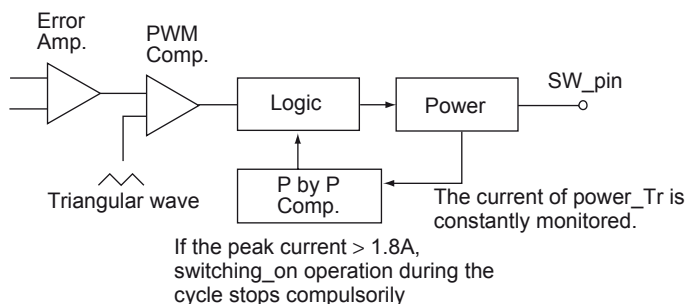

(4) Short Circuit Protector (SCP)

When output voltage of DC/DC decreases due to short-circuit; for example, SCP latches off the outputs of DC/DC and LDO by timer.

When output voltage of DC/DC decreases and FB turns to H, which is the error amplifier output, charge at $4.8\mu\text{A}$ constant current starts to SCP capacitor for timer setting. When SCP voltage exceeds the threshold voltage ($=V_{REF}$), latch-off occurs. If the output voltage recovers until the time the SCP voltage reaches to the threshold voltage, SCP capacitor is discharged and timer is reset. To restart the output after latch-off, you need to input EN signal again. If you do not use the SCP function, make sure to short SCP and GND.

To define timer, you need to calculate a value of SCP capacitor using the following formula because timer (t_{SCP}) depends on capacitance.

$$C_{SCP} = (I_{SCP} \times t_{SCP}) / V_{REF}$$

⟨⟨SCP circuit diagram⟩⟩

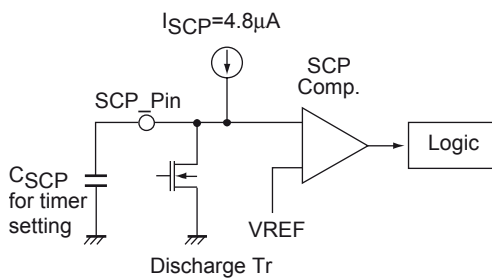

⟨⟨Waveform of SCP_Pin⟩⟩

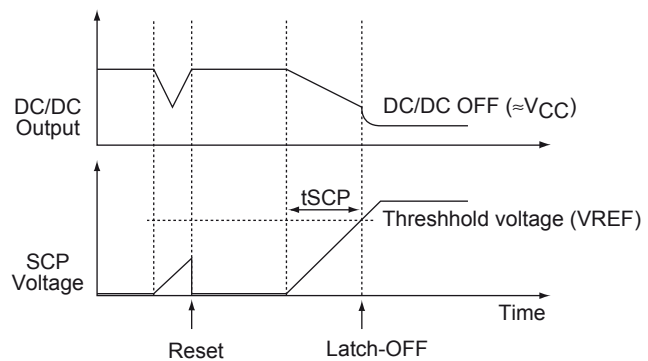

(5) DC/DC on and off control

This function controls on and off of DC/DC during the operation of IC.

⟨⟨Turning on DC/DC⟩⟩

Where DDCTL = Low or open, DC/DC and LDO operate at the same time.

⟨⟨Turning off DC/DC⟩⟩

Where DDCTL = High, DC/DC is compulsorily stopped and only LDO operates.

When DDCTL is switched from H to L (or open), LDO stops temporarily and DC/DC starts with soft start and then LDO restart. If you switch DDCTL during IC operation, make sure that the output waveforms of DC/DC and LDO are normal.

Output voltage setting

Output voltages are given by the following formulas.

$$\text{DCDCOUT} = (1 + R2/R1) \times VREF \text{ [V]}$$

$$\text{LDOOUT} = (1 + R4/R3) \times VREF \text{ [V]}$$

⟨⟨Resistance for output setting⟩⟩

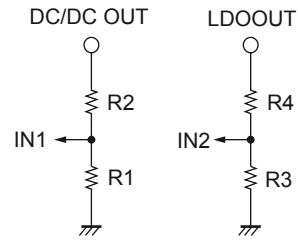

Start and stop

Start: Make sure to input EN signal (L ⇒ H) after supplying $V_{CC} = 12V$.

Stop: Reverse-operation of start.

⟨⟨Output waveform during start and stop⟩⟩

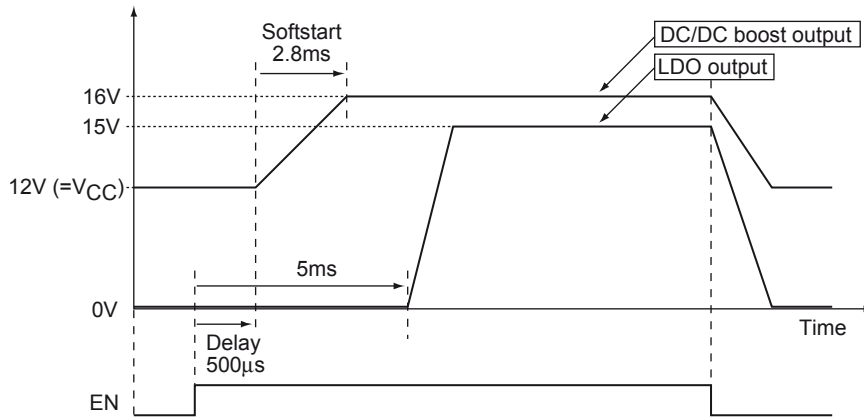

LV56351HA

Block diagram and Application circuit 1 (for BS antenna)

Condition: $V_{CC} = 12V$, $DCDCOUT = 16V$, $LDOOUT = 15V$

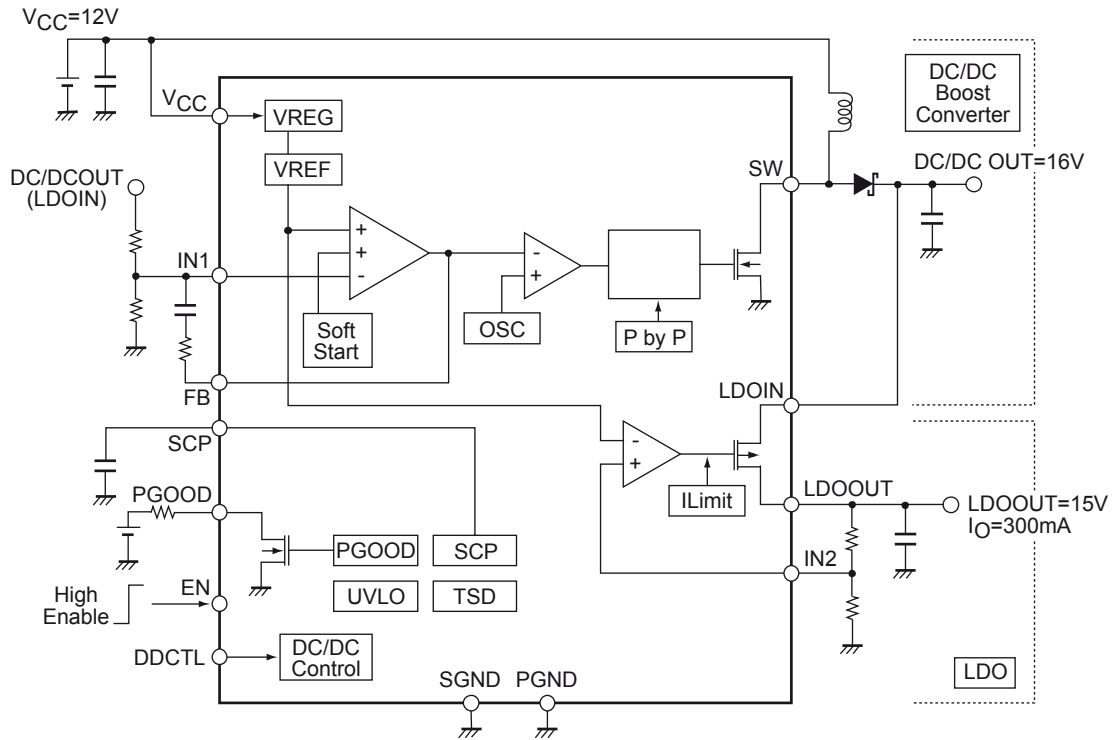

<<Note>>

When LDOOUT is in the over current state or the short-circuit state, IC and external parts are protected by over current limiter of LDO. And when DC/DCOUT is short-circuited, IC stops by timer latch-off type SCP function.

Application circuit 2 (for BS/CS antenna)

BS condition: $V_{CC} = 12V$, $DCDCOUT = 16V$, $LDOOUT = 15V$

CS condition: $V_{CC} = 12V$, $DCDC = OFF$, $LDOOUT = 11V$

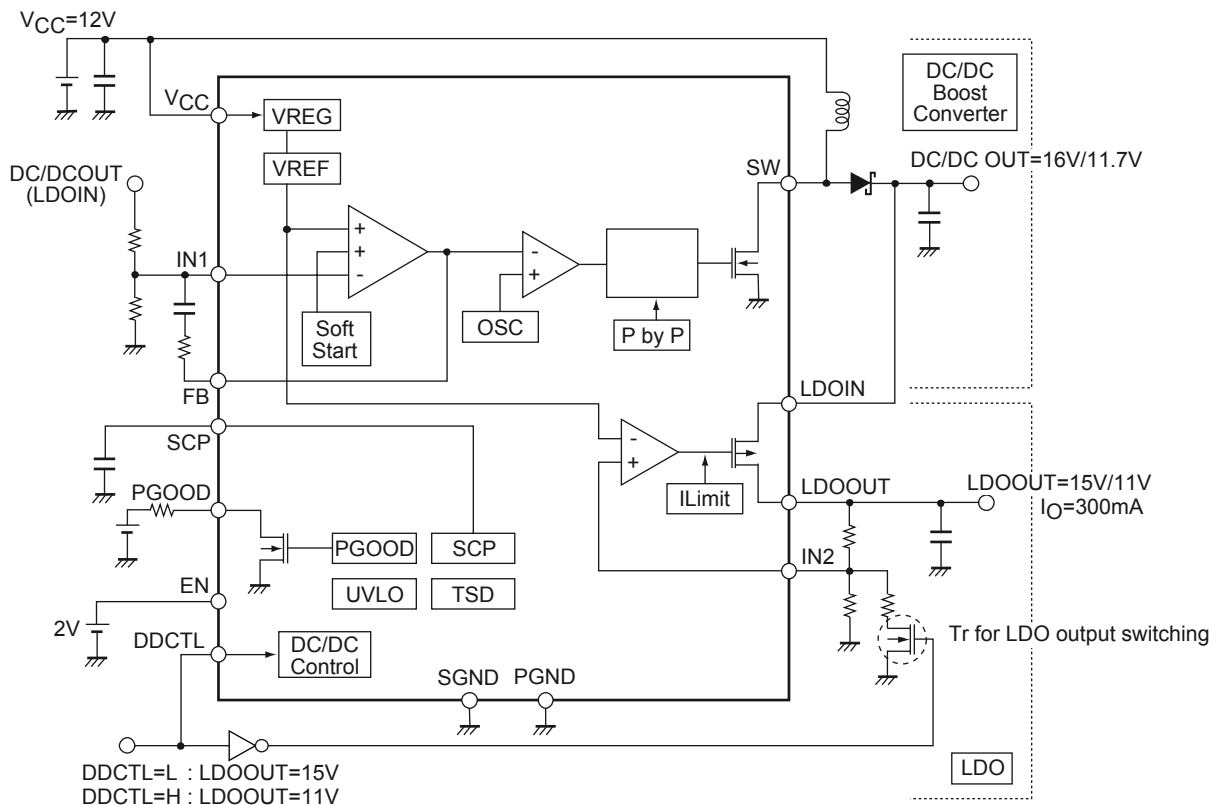

LV56351HA

《(Addition)》

The above application circuit enables switching between 15V for BS and 11V for CS.

Where DDCTL=L, DC/DC booster is turned on and set as follows: DC/DCOUT=16V, LDOOUT=15V

Where DDCTL=H, DC/DC booster is turned off and set as follows: DC/DCOUT=11.7V, LDOOUT=11V
(because the resistance value of output setting of LDO is switched)

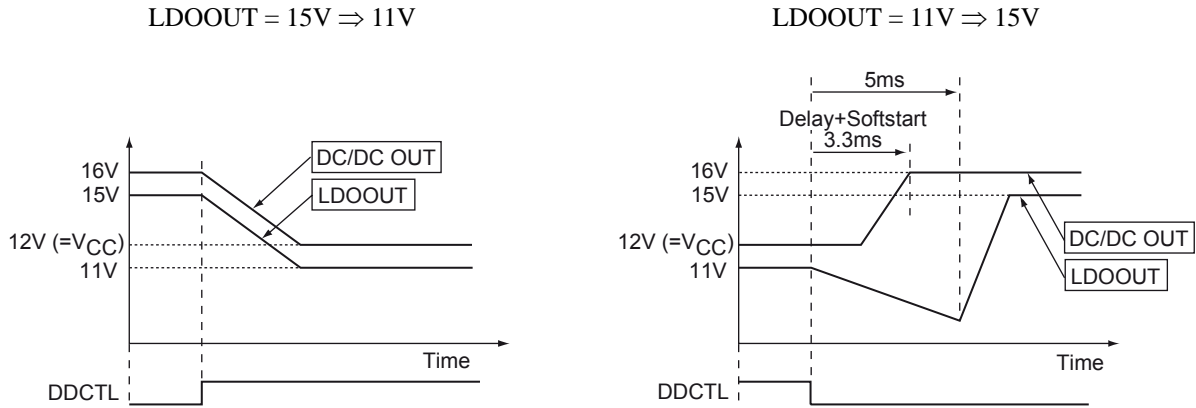

《(Output waveform at switching)》



ON Semiconductor and the ON logo are registered trademarks of Semiconductor Components Industries, LLC (SCILLC). SCILLC owns the rights to a number of patents, trademarks, copyrights, trade secrets, and other intellectual property. A listing of SCILLC's product/patent coverage may be accessed at www.onsemi.com/site/pdf/Patent-Marking.pdf. SCILLC reserves the right to make changes without further notice to any products herein. SCILLC makes no warranty, representation or guarantee regarding the suitability of its products for any particular purpose, nor does SCILLC assume any liability arising out of the application or use of any product or circuit, and specifically disclaims any and all liability, including without limitation special, consequential or incidental damages. "Typical" parameters which may be provided in SCILLC data sheets and/or specifications can and do vary in different applications and actual performance may vary over time. All operating parameters, including "Typicals" must be validated for each customer application by customer's technical experts. SCILLC does not convey any license under its patent rights nor the rights of others. SCILLC products are not designed, intended, or authorized for use as components in systems intended for surgical implant into the body, or other applications intended to support or sustain life, or for any other application in which the failure of the SCILLC product could create a situation where personal injury or death may occur. Should Buyer purchase or use SCILLC products for any such unintended or unauthorized application, Buyer shall indemnify and hold SCILLC and its officers, employees, subsidiaries, affiliates, and distributors harmless against all claims, costs, damages, and expenses, and reasonable attorney fees arising out of, directly or indirectly, any claim of personal injury or death associated with such unintended or unauthorized use, even if such claim alleges that SCILLC was negligent regarding the design or manufacture of the part. SCILLC is an Equal Opportunity/Affirmative Action Employer. This literature is subject to all applicable copyright laws and is not for resale in any manner.

Looking for pricing, stock, or lifecycle information?

Click below to explore more details on WIN SOURCE:

-  [View LV56351HA-AH on WIN SOURCE](#)
-  [ON Semiconductor](#) Information

Optimize Your Supply Chain with WIN SOURCE Solutions

-  Global Sourcing Solution
-  Obsolete Management
-  Cost Control Management
-  Shortage Management
-  Alternative Solution
-  Excess Inventory Management