



**THE DATASHEET OF
JCM3024D12**



30 Watts

- Single and Dual Outputs
- 2:1 Input Range
- 1" x 1" Footprint
- -40 °C to +100 °C Operation
- Full Load at 55 °C Ambient
- 1600 VDC Isolation
- Output Trim $\pm 10\%$
- Remote On/Off
- MTBF 370 kHrs
- 3 Year Warranty



Dimensions:

JCM30:

1.0 x 1.0 x 0.41" (25.4 x 25.0 x 10.4 mm)

Models & Ratings

Input Voltage	Output Voltage	Output Current	Input Current ⁽¹⁾		OVP setting	Efficiency	Max. capacitive load	Model Number ⁽³⁾
			No Load	Full Load				
9-18 V	3.3 V	7.0 A	10 mA	2215 mA	3.9 V	87%	10000 μ F	JCM3012S3V3
	5.0 V	6.0 A	10 mA	2810 mA	6.2 V	89%	7200 μ F	JCM3012S05
	12.0 V	2.5 A	12 mA	2810 mA	15.0 V	89%	1200 μ F	JCM3012S12
	15.0 V	2.0 A	12 mA	2810 mA	18.0 V	89%	1000 μ F	JCM3012S15
	± 12.0 V	± 1.25 A	12 mA	2810 mA	± 15.0 V	89%	± 750 μ F	JCM3012D12
18-36 V	± 15 V	± 1.0 A	14 mA	2780 mA	± 18.0 V	90%	± 500 μ F	JCM3012D15
	3.3 V	7.0 A	10 mA	1105 mA	3.9 V	87%	10000 μ F	JCM3024S3V3
	5 V	6.0 A	10 mA	1390 mA	6.2 V	90%	7200 μ F	JCM3024S05
	12 V	2.5 A	10 mA	1375 mA	15.0 V	91%	1200 μ F	JCM3024S12
	15 V	2.0 A	10 mA	1375 mA	18.0 V	91%	1000 μ F	JCM3024S15
36-75 V	± 12 V	± 1.25 A	10 mA	1375 mA	± 15.0 V	91%	± 750 μ F	JCM3024D12
	± 15 V	± 1.0 A	10 mA	1375 mA	± 18.0 V	92%	± 500 μ F	JCM3024D15
	3.3 V	7.0 A	8 mA	545 mA	3.9 V	88%	10000 μ F	JCM3048S3V3
	5 V	6.0 A	8 mA	695 mA	6.2 V	90%	7200 μ F	JCM3048S05
	12 V	2.5 A	8 mA	695 mA	15.0 V	90%	1200 μ F	JCM3048S12
36-75 V	15 V	2.0 A	8 mA	685 mA	18.0 V	91%	1000 μ F	JCM3048S15
	± 12 V	± 1.25 A	8 mA	685 mA	± 15.0 V	91%	± 750 μ F	JCM3048D12
	± 15 V	± 1.0 A	8 mA	680 mA	± 18.0 V	92%	± 500 μ F	JCM3048D15

Notes

1. Input currents measured at nominal input voltage.
2. Maximum capacitive load is per output.
3. Add suffix '-HK' for optional Heat Sink.

Mechanical Details

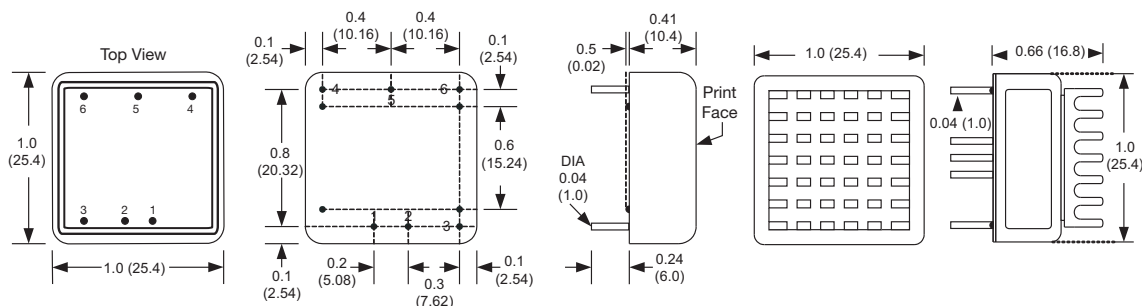

Pin Connections		
Pin	Single	Dual
1	+Vin	+Vin
2	-Vin	-Vin
3	Remote On/Off	Remote On/Off
4	+Vout	+Vout
5	Trim	Common
6	-Vout	-Vout

Notes

1. All dimensions are in inches (mm)
2. Weight: 0.042 lbs (19 g) approx.
3. Pin diameter: 0.04 \pm 0.002 (1.0 \pm 0.05)
4. Pin pitch tolerance: ± 0.014 (± 0.35)
5. Case tolerance: ± 0.02 (± 0.5)

Input

Characteristic	Minimum	Typical	Maximum	Units	Notes & Conditions
Input Voltage Range	9		18	VDC	12 V nominal
	18		36	VDC	24 V nominal
	36		75	VDC	48 V nominal
Input Reflected Ripple Current		30		mA pk-pk	Through 12 μ H inductor and 47 μ F capacitor
Input Surge			25	VDC for 100 ms	12 V models
			50	VDC for 100 ms	24 V models
			100	VDC for 100 ms	48 V models

Output

Characteristic	Minimum	Typical	Maximum	Units	Notes & Conditions
Output Voltage	3.3		30	VDC	See Models and Ratings table
Output Trim	± 10			%	Single Output Versions
Initial Set Accuracy			± 1	%	At full load
Minimum Load	0			%	No minimum load required
Line Regulation			± 0.5	%	From minimum to maximum input at full load
Load Regulation			0.5/1.0	%	From 0% to full load for single/dual output
Cross Regulation			± 5	%	On dual output models, when one output is at 100% load and other is varied from 25% load to full load
Ripple & Noise			75/60	mV pk-pk	Single output 10 μ F X7R MLCC Dual output with 10 μ F/25 V X7R MLCC on each output measured using 20 MHz bandwidth
Overload Protection		150		%	
Short Circuit Protection					Continuous trip and restart (hiccup), with auto recovery
Maximum Capacitive Load					See Models and Ratings table
Temperature Coefficient			0.02	%/°C	
Over Protection Voltage					See Models and Ratings table
Remote On/Off	Output is on if remote on/off (pin 3) is open or high (3.0 to 12 VDC) Output turns off if remote on/off (pin 3) is low (<1.2 VDC max)				

General

Characteristic	Minimum	Typical	Maximum	Units	Notes & Conditions
Efficiency		90		%	See Models and Ratings table
Isolation: Input to Output	1600			VDC	
Isolation: Input to Case	1600			VDC	
Switching Frequency		270		kHz	3.3 and 5.0 V
		330			Other models
Isolation Resistance	10^9			Ω	
Isolation Capacitance			2000	pF	
Power Density			73	W/in ³	
Mean Time Between Failure	370			kHrs	MIL-HDBK-217F, +25 °C GB
Weight		0.042 (19.0)		lb (g)	

Environmental

Characteristic	Minimum	Typical	Maximum	Units	Notes & Conditions
Operating Temperature	-40		+100	°C	See derating curve
Storage Temperature	-55		+125	°C	
Case Temperature			+105	°C	
Humidity			95	%RH	Non-condensing
Cooling					Natural convection

EMC: Emissions

Phenomenon	Standard	Test Level	Notes & Conditions
Conducted	EN55032	Class A	See Application Note
Radiated	EN55032	Class A	

EMC: Immunity

Phenomenon	Standard	Test Level	Criteria	Notes & Conditions
ESD Immunity	EN61000-4-2	±6 kV/±8 kV	A	Contact/Air Discharge
Radiated Immunity	EN61000-4-3	20 V/m	A	
EFT/Burst	EN61000-4-4	2 kV	A	External input filter required, see applications note
Surge	EN61000-4-5	2 kV	A	External input filter required, see applications note
Conducted Immunity	EN61000-4-6	10V	A	
Magnetic Fields	EN61000-4-8	100 A/m	A	

Safety Approvals

Safety Agency	Safety Standard	Notes & Conditions
UL	UL60950-1, UL62368-1	
CSA	CAN/CSA C22.2 No.60950-1	

Mechanical Details

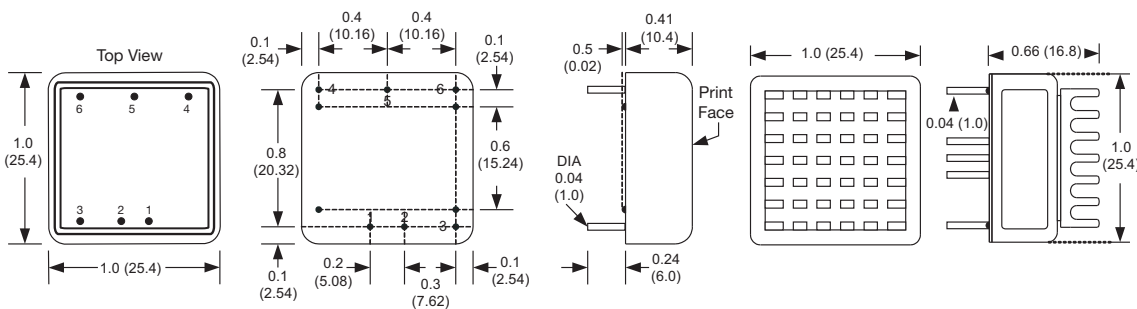

Pin Connections		
Pin	Single	Dual
1	+Vin	+Vin
2	-Vin	-Vin
3	Remote On/Off	Remote On/Off
4	+Vout	+Vout
5	Trim	Common
6	-Vout	-Vout

Notes

- All dimensions are in inches (mm)
- Weight: 0.042 lbs (19 g) approx.
- Pin diameter: 0.04±0.002 (1.0 ±0.05)
- Pin pitch tolerance: ±0.014 (±0.35)
- Case tolerance: ±0.02 (±0.5)

Derating Curve

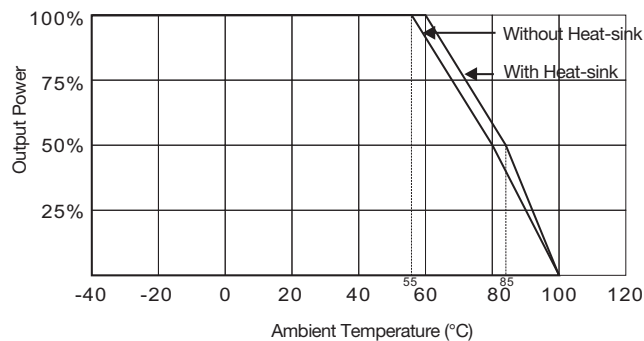

Application Notes

External Output Trimming

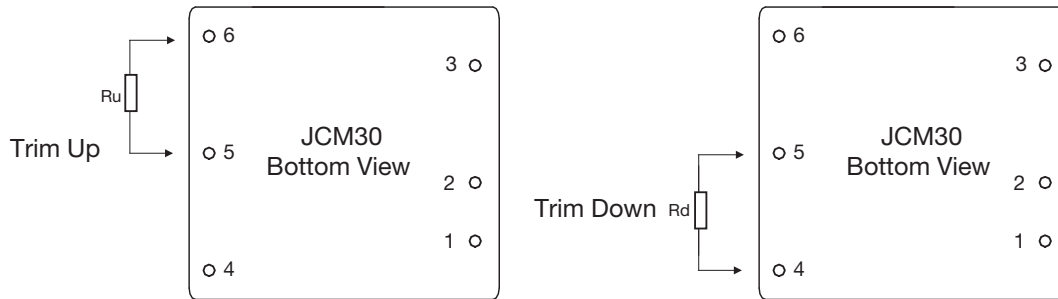

Trim Down Resistor Values (Rd)

Models	1%	2%	3%	4%	5%	6%	7%	8%	9%	10%
3V3	817.5 k	362.2 k	215.4 k	143.0 k	99.7 k	71.1 k	50.6 k	35.3 k	23.4 k	14.0 k
5V	119.9 k	63.6 k	40.4 k	27.7 k	19.7 k	14.2 k	10.2 k	7.1 k	4.7 k	2.7 k
12V	345.0 k	164.8 k	98.9 k	64.6 k	43.7 k	29.6 k	19.4 k	11.7 k	5.7 k	0.87 k
15V	174.3 k	91.1 k	56.6 k	37.7 k	25.8 k	17.6 k	11.6 k	7.0 k	3.5 k	0.55 k

Trim Up Resistor Values (Ru)

Models	1%	2%	3%	4%	5%	6%	7%	8%	9%	10%
3V3	567.6 k	263.2 k	158.5 k	105.5 k	73.5 k	52.1 k	36.8 k	25.2 k	16.3 k	9.1 k
5V	618.0 k	223.4 k	133.3 k	93.4 k	70.9 k	56.4 k	46.4 k	38.9 k	33.2 k	28.7 k
12V	1015.7 k	448.9 k	280.6 k	199.8 k	152.4 k	121.2 k	99.1 k	82.6 k	69.9 k	59.7 k
15V	661.5 k	231.3 k	134.0 k	91.0 k	66.8 k	51.3 k	40.4 k	32.5 k	26.4 k	21.5 k

EMI Filter (Only needed for 12 V input versions)

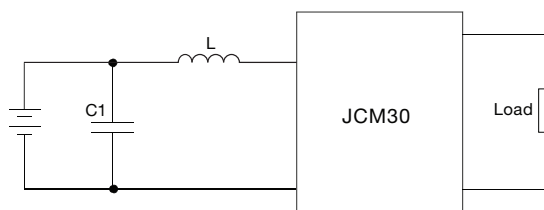

C1 = 1206, 335 k/50 V, X7R
L = 0.82 μ H

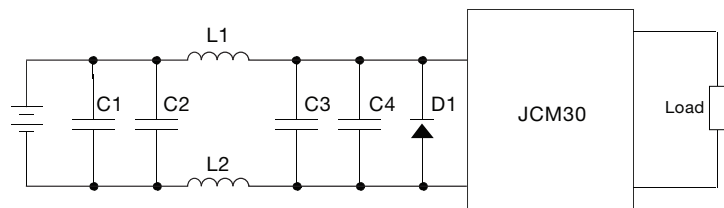

EFT/Surge Filter









	C1	C2	L1	L2	C3	C4	D1
JCM3012	330 μ F/100 V	470 μ F/100 V	1 μ H	1 μ H	330 μ F/100	470 μ F/100	None
JCM3024	330 μ F/100 V	None	Short	Short	None	None	TVS, 58 V, 3 kW
JCM3048	330 μ F/100 V	None	Short	Short	None	None	TVS, 120 V, 3 kW

Looking for pricing, stock, or lifecycle information?

Click below to explore more details on WIN SOURCE:

-  [View JCM3024D12 on WIN SOURCE](#)
-  [XP Power Information](#)

Optimize Your Supply Chain with WIN SOURCE Solutions

-  Global Sourcing Solution
-  Obsolete Management
-  Cost Control Management
-  Shortage Management
-  Alternative Solution
-  Excess Inventory Management