



**THE DATASHEET OF  
AUIR3317**



**LOW EMI CURRENT SENSE HIGH SIDE SWITCH**

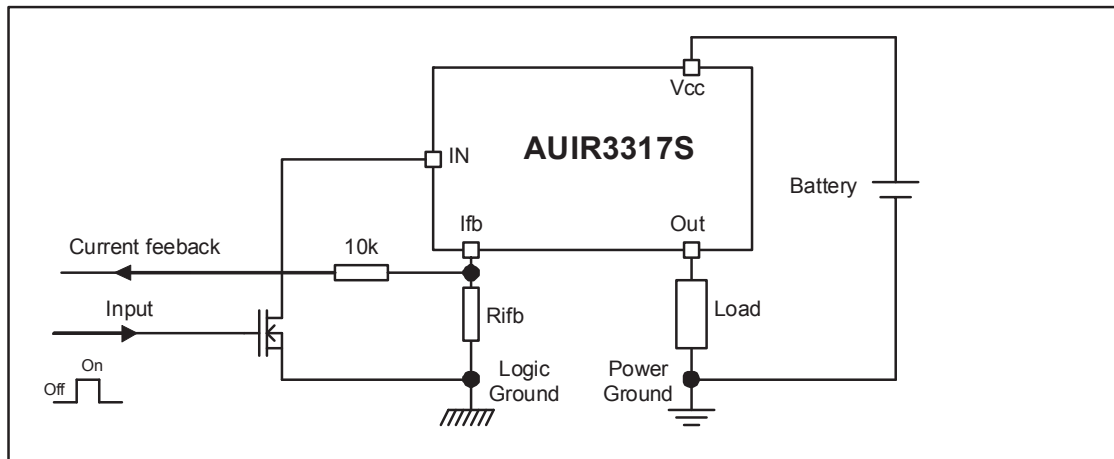
**Features**

- Load current feedback
- Over current shutdown
- Active clamp
- ESD protection
- Input referenced to Vcc
- Over temperature shutdown
- Switching time optimized for low EMI
- Reverse battery protection

**Description**

The AUIR3317(S) is a fully protected 4 terminals high side switch. The input signal is referenced to Vcc. When the input voltage Vcc - Vin is higher than the specified threshold, the output power Mosfet is turned on. When the Vcc - Vin is lower than the specified Vil threshold, the output Mosfet is turned off. A current proportional to the power Mosfet current is sourced to the Ifb pin. Either over current and over temperature latches off the switch. The device is reset by pulling the input pin high. Other integrated protections (ESD, reverse battery, active clamp) make the switch very rugged in automotive environment.

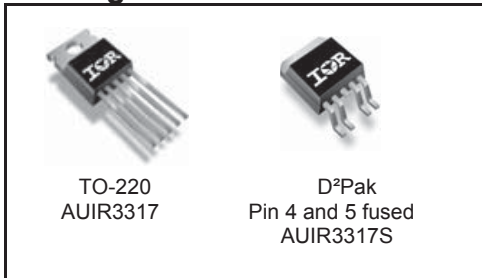
**Typical Connection**



**Product Summary**

Rds(on)	7 mΩ max.
Vcc op.	6 to 26V
Current Ratio	8800
Over-current	120A
Vclamp	40V

**Package**



**Qualification Information<sup>†</sup>**

<b>Qualification Level</b>		Automotive (per AEC-Q100 <sup>††</sup> )	
		Comments: This family of ICs has passed an Automotive qualification. IR's Industrial and Consumer qualification level is granted by extension of the higher Automotive level.	
<b>Moisture Sensitivity Level</b>		D2PAK-5L	MSL1, 260°C (per IPC/JEDEC J-STD-020)
		TO220-5L	Not applicable
<b>ESD</b>	Machine Model	Class M4 (450V) (per AEC-Q100-003)	
	Human Body Model	Class H3A (4,500 V) (per AEC-Q100-002)	
	Charged Device Model	Class C4 (1000 V) (per AEC-Q100-011)	
<b>IC Latch-Up Test</b>		Class II, Level A (per AEC-Q100-004)	
<b>RoHS Compliant</b>		Yes	

<sup>†</sup> Qualification standards can be found at International Rectifier's web site <http://www.irf.com/>

<sup>††</sup> Exceptions to AEC-Q100 requirements are noted in the qualification report.

### Absolute Maximum Ratings

Absolute maximum ratings indicate sustained limits beyond which damage to the device may occur. All voltage parameters are referenced to Vcc lead. (Tj=-40°..150°C, Vcc=6..26V Tambient=25°C unless otherwise specified).

Symbol	Parameter	Min.	Max.	Units
Vcc-Vin	Maximum Vcc voltage	-16	37	V
Vcc-Vin cont.	Maximum continuous Vcc voltage	-16	26	
Vcc-Vfb	Maximum lfb voltage	-16	33	
Vcc-Vout	Maximum output voltage	-0.3	37	A
I <sub>ds</sub> cont.	Maximum body diode continuous current Rth=60°C/W (1) Tambient=25°C	—	2.8	
I <sub>ds</sub> pulsed	Maximum body diode pulsed current (1)	—	100	W
Pd	Maximum power dissipation Rth=60°C/W Tambient=25°C	—	2	
Tj max.	Max. storage & operating temperature junction temperature	-40	150	°C
Min Rfb	Minimum on the resistor on lfb pin	0.3	—	kΩ
I <sub>fb</sub> max.	Max. lfb current	-50	50	mA

(1) Limited by junction temperature. Pulsed is also limited by wiring

### Thermal Characteristics

Symbol	Parameter	Typ.	Max.	Units
Rth1	Thermal resistance junction to ambient D <sup>2</sup> -Pak Std footprint	60	—	°C/W
Rth2	Thermal resistance junction to case D <sup>2</sup> -Pak	0.7	—	
Rth2	Thermal resistance junction to case TO220	0.7	—	

### Recommended Operating Conditions

These values are given for a quick design. For operation outside these conditions, please consult the application notes.

Symbol	Parameter	Min.	Max.	Units
I <sub>out</sub>	Continuous output current	—	23 7	A
	Tambient=85°C, Rth=5°C/W, Tj=125°C			
	Tambient=85°C, Rth=60°C/W, Tj=125°C			
Pulse min.	Minimum turn-on pulse width	1	—	ms
F <sub>max</sub>	Maximum operating frequency	—	200	Hz

### Protection Characteristics

T<sub>j</sub>=-40°..150°C, V<sub>cc</sub>=6..26V

Symbol	Parameter	Min.	Typ.	Max.	Units	Test Conditions
Tsd	Over temperature threshold	—	165	—	°C	See fig. 5
OV	Over voltage protection (not latched)	26	29	33	V	
Isdf	Fixed over current shutdown	90	120	150	A	V <sub>cc</sub> -V <sub>ifb</sub> >4V(3)
treset	Time to reset protection	—	50	500	μs	See fig. 5
Min. pulse	Min. pulse width (no WAIT state)	—	900	2000		T <sub>j</sub> =25°C
WAIT	WAIT function timer	0.4	1	2	ms	See fig. 4 and 5
Rds(on) rev.	Reverse battery On state resistance	4	6.7	10	mΩ	V <sub>cc</sub> -V <sub>in</sub> =-14V, I <sub>out</sub> =30A
	T <sub>j</sub> =25°C	—	10	15		
	T <sub>j</sub> =125°C	—	10	15		

(3) With V<sub>cc</sub>-V<sub>ifb</sub><4V, the Isdf is lower than specified in the datasheet

### Static Electrical Characteristics

T<sub>j</sub>=-40°..150°C, V<sub>cc</sub>=6..26V (unless otherwise specified)

Symbol	Parameter	Min.	Typ.	Max.	Units	Test Conditions
V <sub>cc op.</sub>	Operating Voltage range	6	—	26	V	
I <sub>cc off</sub>	Supply leakage current	—	1.5	5	μA	V <sub>in</sub> =V <sub>cc</sub> , V <sub>cc</sub> -V <sub>out</sub> =14V, V <sub>cc</sub> -V <sub>ifb</sub> =14V, T <sub>j</sub> =25°C
I <sub>in, on</sub>	On state I <sub>N</sub> positive current	1.5	3	6	mA	V <sub>cc</sub> -V <sub>in</sub> =14V, T <sub>j</sub> =25°C
V <sub>ih</sub>	High level Input threshold voltage (4)	—	5.4	6.3	V	
V <sub>il</sub>	Low level Input threshold voltage (4)	4	4.9	5.8		
V <sub>hyst</sub>	Input hysteresis V <sub>ih</sub> -V <sub>il</sub>	0.2	0.4	1.5		
I <sub>out</sub>	Drain to source leakage current	—	1.2	5	μA	V <sub>in</sub> =V <sub>cc</sub> , V <sub>cc</sub> -V <sub>ifb</sub> =0V, V <sub>cc</sub> -V <sub>out</sub> =14V, T <sub>j</sub> =25°C
Rds(on)	On state resistance (5) T <sub>j</sub> =25°C	4	5.5	7	mΩ	I <sub>out</sub> =30A, V <sub>cc</sub> -V <sub>in</sub> =14V
	On state resistance (5) T <sub>j</sub> =25°C	4	6	10		I <sub>out</sub> =17A, V <sub>cc</sub> -V <sub>in</sub> =6V
	On state resistance (5)(6) T <sub>j</sub> =150°C	7	10.5	13.5		I <sub>out</sub> =30A, V <sub>cc</sub> -V <sub>in</sub> =14V
V <sub>clamp1</sub>	V <sub>cc</sub> to V <sub>out</sub> clamp voltage 1	36	39	—	V	I <sub>out</sub> =50mA
V <sub>clamp2</sub>	V <sub>cc</sub> to V <sub>out</sub> clamp voltage 2	—	40	43		I <sub>out</sub> =30A, T <sub>j</sub> =25°C

(4) Input thresholds are measured directly between the input pin and the tab. Any parasitic resistance in common between the load current path and the input signal path can significantly affect the thresholds.

(5) R<sub>dson</sub> is measured between the tab and the Out pin, 5mm away from the package.

(6) Guaranteed by design

### Switching Electrical Characteristics

V<sub>cc</sub>=14V, Resistive load=0.5Ω, T<sub>j</sub>=25°C

Symbol	Parameter	Min.	Typ.	Max.	Units	Test Conditions
t <sub>don</sub>	Turn on delay time to 10% V <sub>cc</sub>	30	120	300	μs	See figure 2
t <sub>r1</sub>	Rise time to V <sub>cc</sub> -V <sub>out</sub> =5V	20	50	125		
t <sub>r2</sub>	Rise time to V <sub>cc</sub> -V <sub>out</sub> =0.1V <sub>cc</sub>	30	80	200		
E <sub>on</sub>	Turn on energy	—	14	—	mJ	
t <sub>doff</sub>	Turn off delay time	30	140	350	μs	
t <sub>f</sub>	Fall time to V <sub>out</sub> =10% of V <sub>cc</sub>	35	100	250		
E <sub>off</sub>	Turn off energy	—	7	—	mJ	



## Lead Assignments

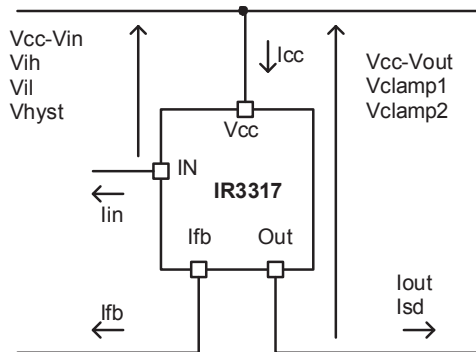
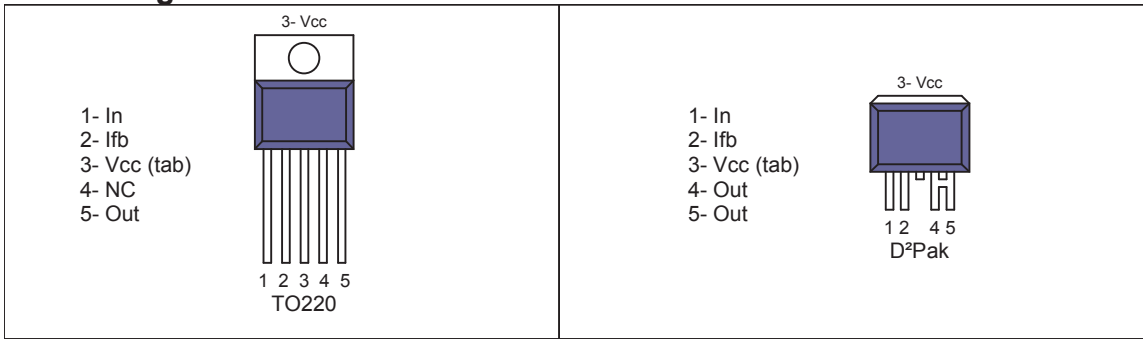


Figure 1 – Voltages and current definitions

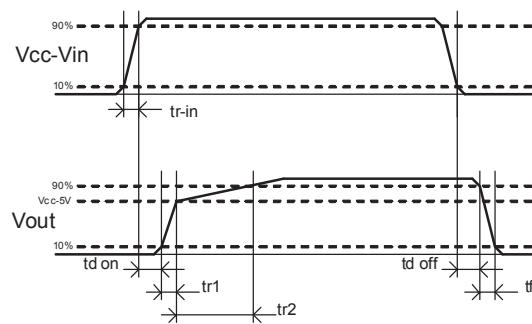
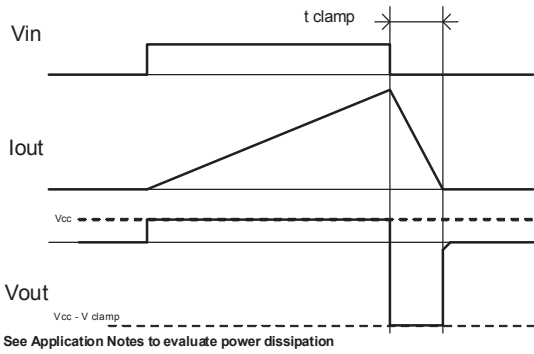
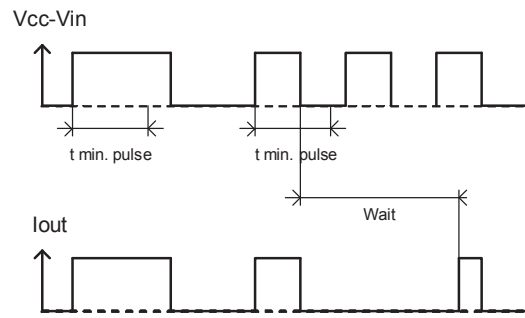


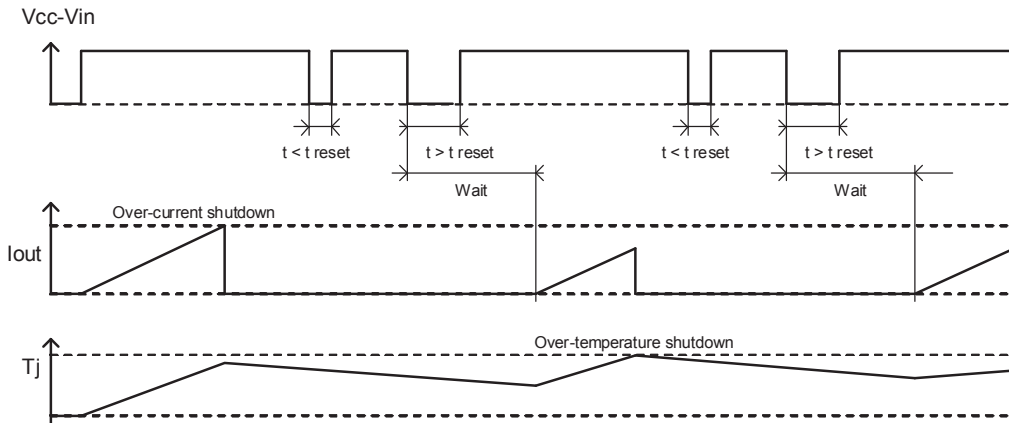
Figure 2 – Switching time definitions



**Figure 3 – Active clamp waveforms**

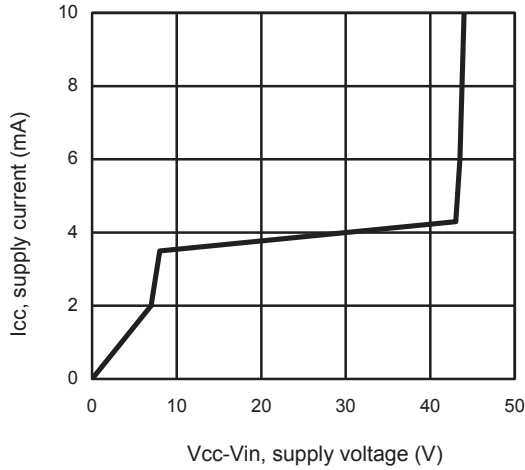


**Figure 4 – Min. pulse and Wait function**

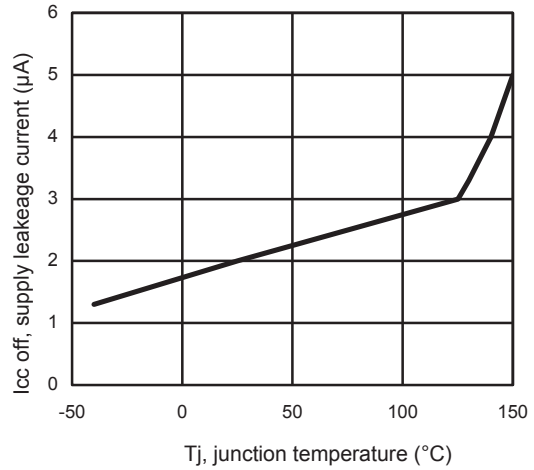


**Figure 5 – Protection Timing Diagrams**

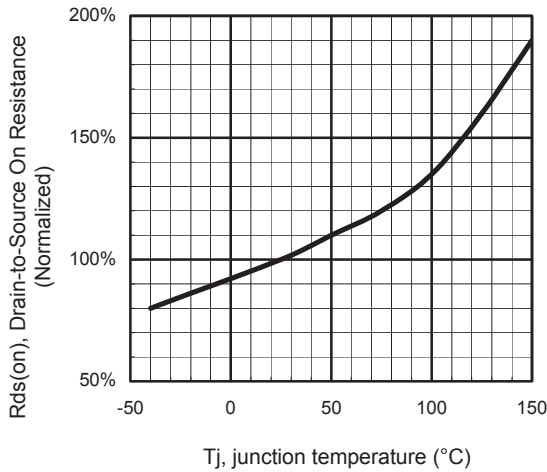
All curves are typical characteristics. Operation in hatched areas is not recommended.  $T_j=25^\circ\text{C}$ ,  $R_{\text{th}\theta}=500\text{ohm}$ ,  $V_{\text{cc}}=14\text{V}$  (unless otherwise specified).



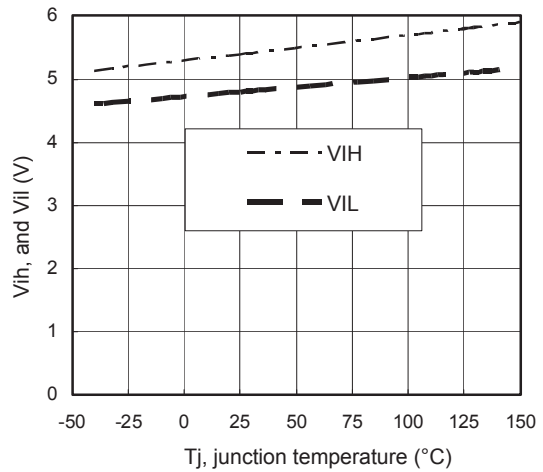
**Figure 6 – Icc (mA) Vs Vcc-Vin (V)**



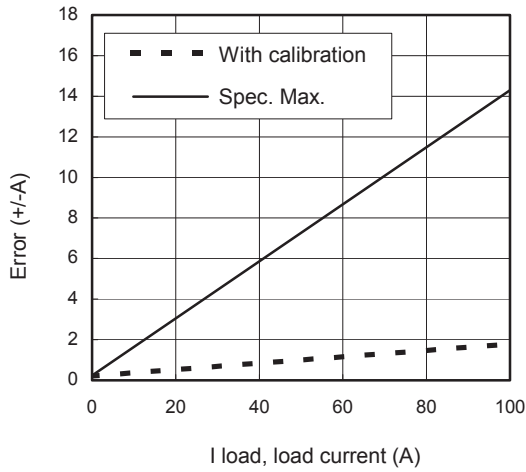
**Figure 7 – Icc off (µA) Vs Tj (°C)**



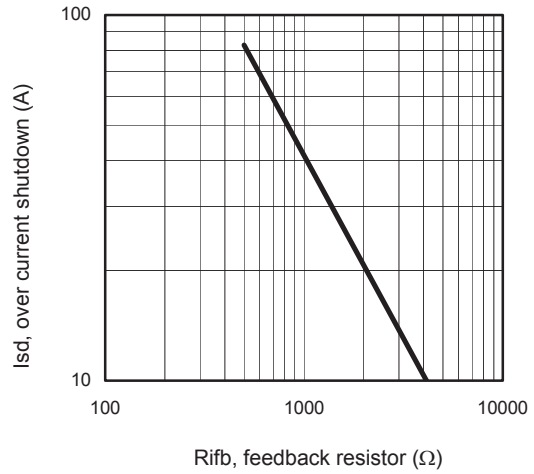
**Figure 8 - Normalized Rds(on) (%) Vs Tj (°C)**



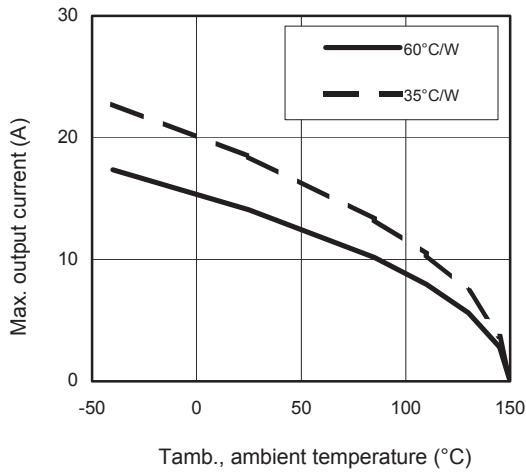
**Figure 9 – Vih and Vil (V) Vs Tj (°C)**



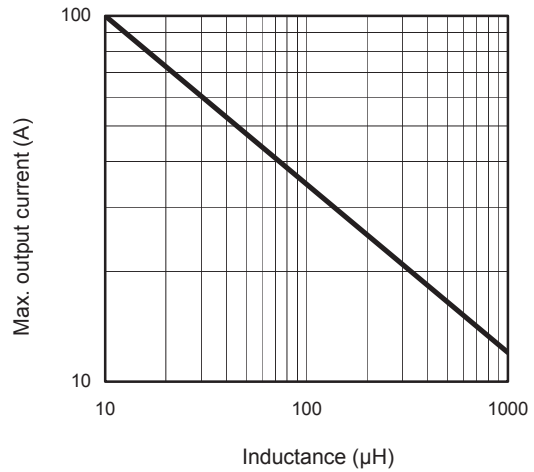
**Figure 10 – Error (+/- A) Vs I load (A)**



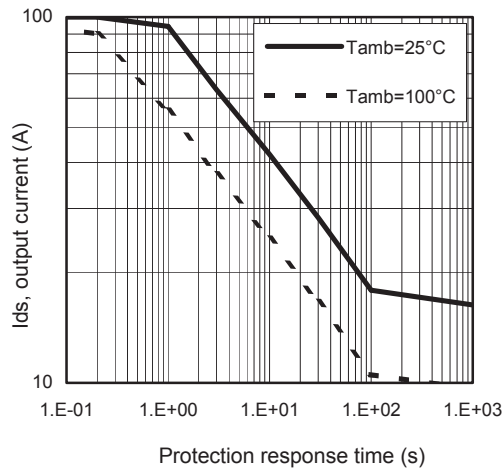
**Figure 11 – Ids (A) Vs Rifb (Ω)**



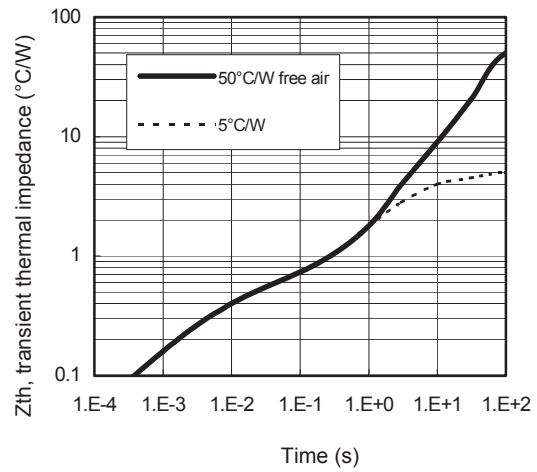
**Figure 12 – Max. iout (A) Vs Tamb. (°C)**



**Figure 13 – Max. iout (A) Vs inductance (μH)**

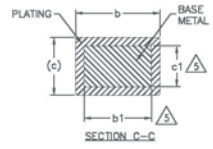
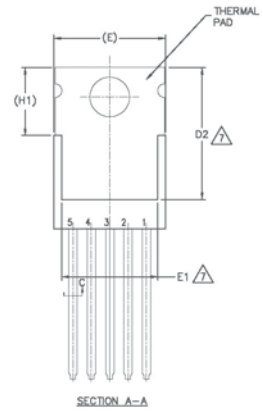
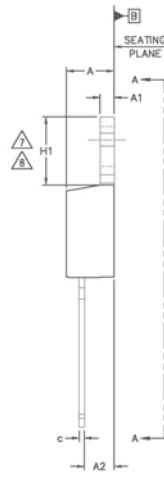
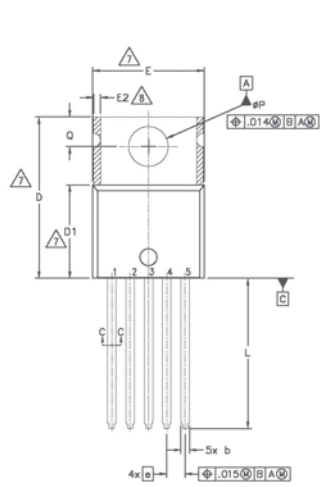


**Figure 14 –  $I_{ds}$  (A) Vs over temperature protection response time (s)**



**Figure 15 – Transient thermal impedance (°C/W) Vs time (s)**

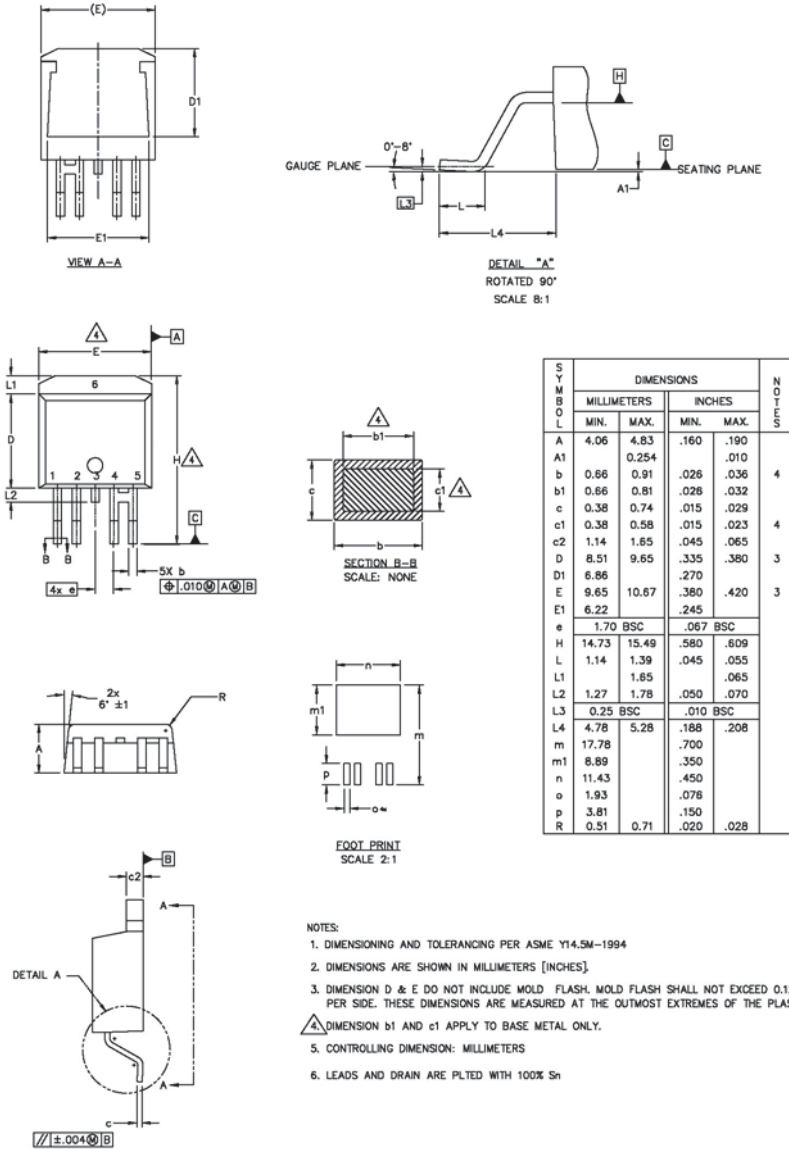
## Case Outline - TO220 - 5 Leads



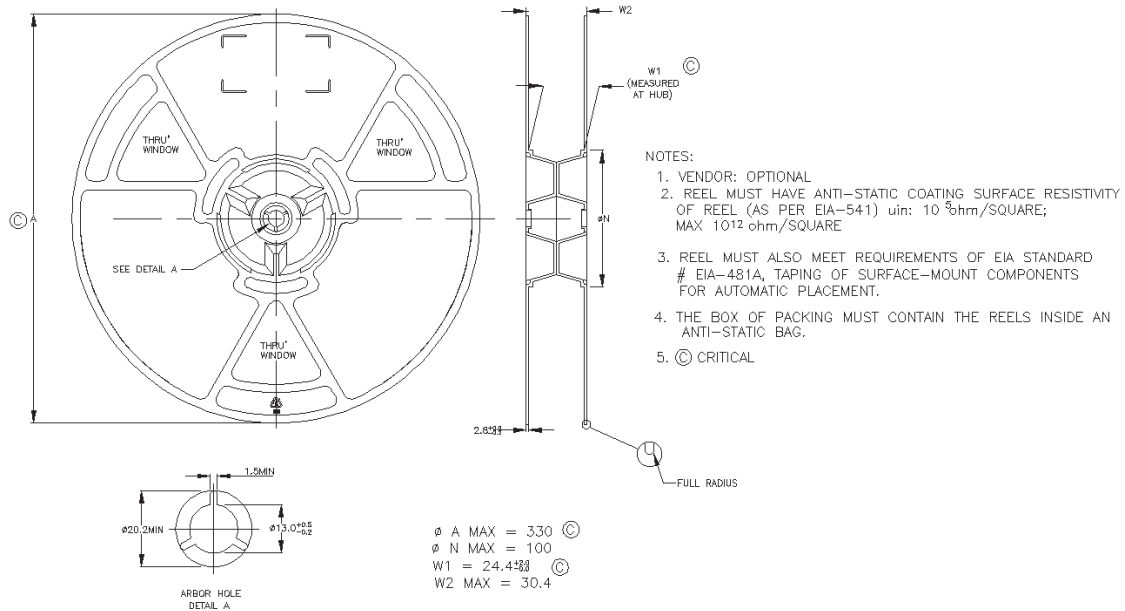
SYMBOL	DIMENSIONS				NOTES
	MILLIMETERS		INCHES		
	MIN.	MAX.	MIN.	MAX.	
A	3.56	4.83	.140	.190	
A1	0.51	1.40	.020	.055	
A2	2.03	2.92	.080	.115	
b	0.64	0.89	.025	.035	
b1	0.64	0.84	.025	.033	5
c	0.36	0.61	.014	.024	
c1	0.36	0.56	.014	.022	5
D	14.22	16.51	.560	.650	4
D1	8.38	9.02	.330	.355	
D2	11.68	12.88	.460	.507	7
E	9.65	10.67	.380	.420	4,7
E1	6.86	8.89	.270	.350	7
E2	-	0.76	-	.030	8
e	1.70 BSC		.067 BSC		7,8
H1	5.84	6.86	.230	.270	
L	12.70	14.73	.500	.580	
MP	3.53	3.73	.139	.147	
Q	2.54	3.05	.100	.120	

- NOTES:
- 1.- DIMENSIONING AND TOLERANCING AS PER ASME Y14.5 M-1994.
  - 2.- DIMENSIONS ARE SHOWN IN INCHES [MILLIMETERS].
  - 3.- LEAD DIMENSION AND FINISH UNCONTROLLED IN L1.
  - 4.- DIMENSION D, D1 & E DO NOT INCLUDE MOLD FLASH. MOLD FLASH SHALL NOT EXCEED .005" (0.127) PER SIDE. THESE DIMENSIONS ARE MEASURED AT THE OUTERMOST EXTREMES OF THE PLASTIC BODY.
  - 5.- DIMENSION b1 & c1 APPLY TO BASE METAL ONLY.
  - 6.- CONTROLLING DIMENSION : INCHES.
  - 7.- THERMAL PAD CONTOUR OPTIONAL WITHIN DIMENSIONS E,H1,D2 & E1
  - 8.- DIMENSION E2 X H1 DEFINE A ZONE WHERE STAMPING AND SINGULATION IRREGULARITIES ARE ALLOWED.
  - 9.- OUTLINE CONFORMS TO JEDEC TO-220, EXCEPT A2 (max.) AND D2 (min.) WHERE DIMENSIONS ARE DERIVED FROM THE ACTUAL PACKAGE OUTLINE.
  - 10.- LEADS AND DRAIN ARE PLATED WITH 100X 5n

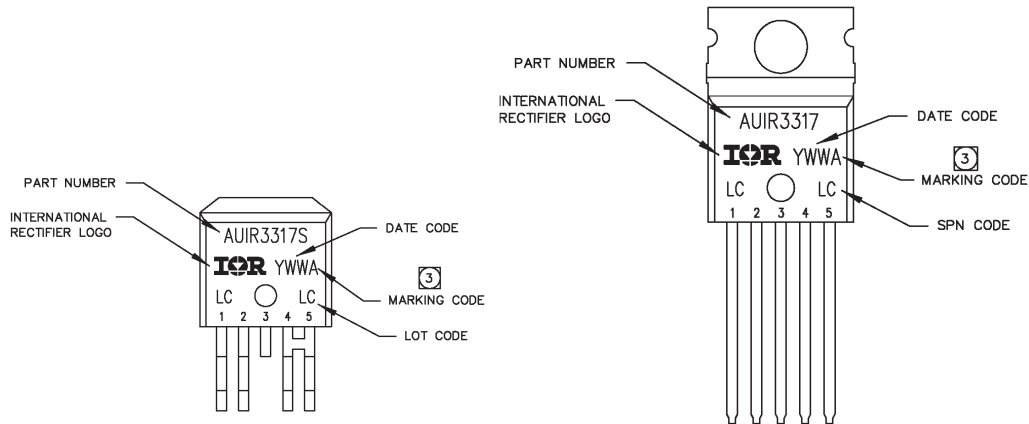
Case Outline - D2PAK – 5 leads



**Tape & Reel - D2PAK – 5 leads**



## Part Marking Information



## Ordering Information

Base Part Number	Package Type	Standard Pack		Complete Part Number
		Form	Quantity	
AUIR3317	TO220 – 5Leads	Tube	50	AUIR3317
		Tube	50	AUIR3317S
	D2Pak – 5Leads	Tape and reel left	800	AUIR3317STRL
		Tape and reel right	800	AUIR3317STRR

**IMPORTANT NOTICE**

Unless specifically designated for the automotive market, International Rectifier Corporation and its subsidiaries (IR) reserve the right to make corrections, modifications, enhancements, improvements, and other changes to its products and services at any time and to discontinue any product or services without notice. Part numbers designated with the "AU" prefix follow automotive industry and / or customer specific requirements with regards to product discontinuance and process change notification. All products are sold subject to IR's terms and conditions of sale supplied at the time of order acknowledgment.

IR warrants performance of its hardware products to the specifications applicable at the time of sale in accordance with IR's standard warranty. Testing and other quality control techniques are used to the extent IR deems necessary to support this warranty. Except where mandated by government requirements, testing of all parameters of each product is not necessarily performed.

IR assumes no liability for applications assistance or customer product design. Customers are responsible for their products and applications using IR components. To minimize the risks with customer products and applications, customers should provide adequate design and operating safeguards.

Reproduction of IR information in IR data books or data sheets is permissible only if reproduction is without alteration and is accompanied by all associated warranties, conditions, limitations, and notices. Reproduction of this information with alterations is an unfair and deceptive business practice. IR is not responsible or liable for such altered documentation. Information of third parties may be subject to additional restrictions.

Resale of IR products or serviced with statements different from or beyond the parameters stated by IR for that product or service voids all express and any implied warranties for the associated IR product or service and is an unfair and deceptive business practice. IR is not responsible or liable for any such statements.

IR products are not designed, intended, or authorized for use as components in systems intended for surgical implant into the body, or in other applications intended to support or sustain life, or in any other application in which the failure of the IR product could create a situation where personal injury or death may occur. Should Buyer purchase or use IR products for any such unintended or unauthorized application, Buyer shall indemnify and hold International Rectifier and its officers, employees, subsidiaries, affiliates, and distributors harmless against all claims, costs, damages, and expenses, and reasonable attorney fees arising out of, directly or indirectly, any claim of personal injury or death associated with such unintended or unauthorized use, even if such claim alleges that IR was negligent regarding the design or manufacture of the product.

Only products certified as military grade by the Defense Logistics Agency (DLA) of the US Department of Defense, are designed and manufactured to meet DLA military specifications required by certain military, aerospace or other applications. Buyers acknowledge and agree that any use of IR products not certified by DLA as military-grade, in applications requiring military grade products, is solely at the Buyer's own risk and that they are solely responsible for compliance with all legal and regulatory requirements in connection with such use.

For technical support, please contact IR's Technical Assistance Center  
<http://www.irf.com/technical-info/>

**WORLD HEADQUARTERS:**  
101 N. Sepulveda Blvd., El Segundo, California 90245  
Tel: (310) 252-7105

**Revision History**

<b>Revision</b>	<b>Date</b>	<b>Notes/Changes</b>
A		First release
B	10/06/2010	AU release
C	25/08/2011	Add test condition to Isdf page 4

## Looking for pricing, stock, or lifecycle information?

Click below to explore more details on WIN SOURCE:

 [View AUIR3317](#) on WIN SOURCE

 [Infineon Technologies](#) Information

## Optimize Your Supply Chain with WIN SOURCE Solutions

-  Global Sourcing Solution
-  Obsolete Management
-  Cost Control Management
-  Shortage Management
-  Alternative Solution
-  Excess Inventory Management