





# Dual 10-Bit, 120MSPS, 3.3V, Low-Power ADC with Internal Reference and Parallel Outputs

## General Description

The MAX1190 is a 3.3V, dual 10-bit analog-to-digital converter (ADC) featuring fully differential wideband track-and-hold (T/H) inputs, driving two ADCs. The MAX1190 is optimized for low power, small size, and high-dynamic performance for applications in imaging, instrumentation, and digital communications. This ADC operates from a single 3.1V to 3.6V supply, consuming only 492mW while delivering a typical signal-to-noise and distortion (SINAD) of 57dB at an input frequency of 60MHz and a sampling rate of 120MSPS. The T/H driven input stages incorporate 400MHz (-3dB) input amplifiers. The converters can also be operated with single-ended inputs. In addition to low operating power, the MAX1190 features a 3mA sleep mode, as well as a 1 $\mu$ A power-down mode to conserve power during idle periods.

An internal 2.048V precision bandgap reference sets the full-scale range of the ADC. A flexible reference structure allows the use of this internal or an externally applied reference, if desired, for applications requiring increased accuracy or a different input voltage range.

The MAX1190 features parallel, CMOS-compatible three-state outputs. The digital output format can be set to two's complement or straight offset binary through a single control pin. The device provides for a separate output power supply of 1.7V to 3.6V for flexible interfacing with various logic families. The MAX1190 is available in a 7mm x 7mm, 48-pin TQFP-EP package, and is specified for the extended industrial (-40°C to +85°C) temperature range.

Pin-compatible lower speed versions of the MAX1190 are also available. Refer to the MAX1180–MAX1184 data sheets for 105MSPS/80MSPS/65MSPS/40MSPS. In addition to these speed grades, this family includes two multiplexed output versions (MAX1185/MAX1186 for 20MSPS/40MSPS), for which digital data is presented time-interleaved and on a single, parallel 10-bit output port.

For lower speed, pin-compatible, 8-bit versions of the MAX1190, refer to the MAX1195–MAX1198 data sheets.

## Applications

- Baseband I/Q Sampling
- Multichannel IF Sampling
- Ultrasound and Medical Imaging
- Battery-Powered Instrumentation
- WLAN, WWAN, WLL, MMDS Modems
- Set-Top Boxes
- VSAT Terminals

Functional Diagram appears at end of data sheet.



## Features

- ◆ Single 3.3V Operation
- ◆ Excellent Dynamic Performance
  - 57dB SINAD at  $f_{IN} = 60\text{MHz}$
  - 64dBc SFDR at  $f_{IN} = 60\text{MHz}$
- ◆ -71dBc Interchannel Crosstalk at  $f_{IN} = 60\text{MHz}$
- ◆ Low Power
  - 492mW (Normal Operation)
  - 10mW (Sleep Mode)
  - 3.3 $\mu$ W (Shutdown Mode)
- ◆ 0.08dB Gain and 0.8° Phase Matching
- ◆ Wide  $\pm 1\text{V}_{p-p}$  Differential Analog Input Voltage Range
- ◆ 400MHz -3dB Input Bandwidth
- ◆ On-Chip 2.048V Precision Bandgap Reference
- ◆ User-Selectable Output Format—Two's Complement or Offset Binary
- ◆ Pin-Compatible, Lower-Speed, 10-Bit and 8-Bit Versions Available

## Ordering Information

PART	TEMP RANGE	PIN-PACKAGE	PKG CODE
MAX1190ECM	-40°C to +85°C	48 TQFP-EP*	C48E-7
MAX1190ECM+	-40°C to +85°C	48 TQFP-EP*	C48E-7

\*EP = Exposed paddle.

+Denotes lead-free package.

## Pin Configuration

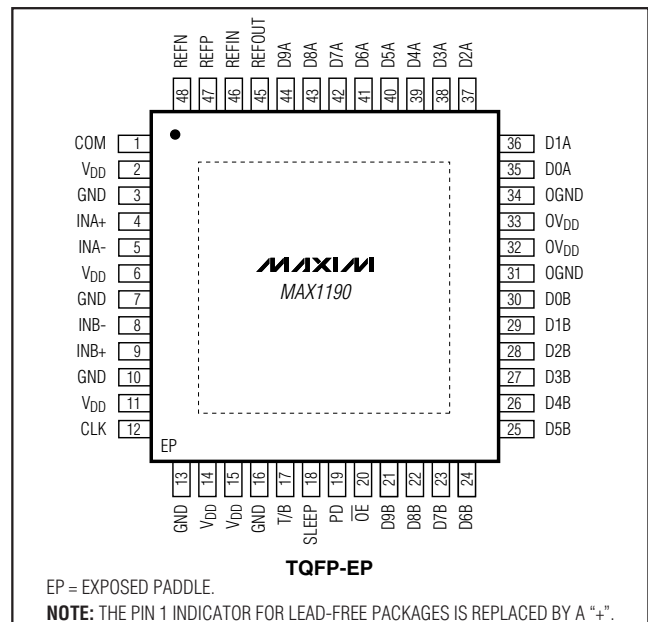

MAX1190

# Dual 10-Bit, 120MSPS, 3.3V, Low-Power ADC with Internal Reference and Parallel Outputs

## ABSOLUTE MAXIMUM RATINGS

V <sub>DD</sub> , OV <sub>DD</sub> to GND .....	-0.3V to +3.6V
OGND to GND .....	-0.3V to +0.3V
INA+, INA-, INB+, INB- to GND .....	-0.3V to V <sub>DD</sub>
REFIN, REFOUT, REFP, REFN, COM, CLK to GND .....	-0.3V to (V <sub>DD</sub> + 0.3V)
OE, PD, SLEEP, T/B, D9A–D0A, D9B–D0B to OGND .....	-0.3V to (OV <sub>DD</sub> + 0.3V)

Continuous Power Dissipation (T <sub>A</sub> = +70°C) 48-Pin TQFP-EP (derate 30.4mW/°C above +70°C) ..	2430mW
Operating Temperature Range .....	-40°C to +85°C
Junction Temperature .....	+150°C
Storage Temperature Range .....	-60°C to +150°C
Lead Temperature (soldering, 10s) .....	+300°C

Stresses beyond those listed under "Absolute Maximum Ratings" may cause permanent damage to the device. These are stress ratings only, and functional operation of the device at these or any other conditions beyond those indicated in the operational sections of the specifications is not implied. Exposure to absolute maximum rating conditions for extended periods may affect device reliability.

## ELECTRICAL CHARACTERISTICS

(V<sub>DD</sub> = 3.3V; OV<sub>DD</sub> = 2V; 0.1μF and 1.0μF capacitors from REFP, REFN, and COM to GND, REFOUT connected to REFIN through a 10kΩ resistor; V<sub>REFIN</sub> = 2.048V; V<sub>IN</sub> = 2V<sub>P-P</sub> (differential with respect to COM); C<sub>L</sub> = 10pF at digital outputs; f<sub>CLK</sub> = 120MHz; T<sub>A</sub> = T<sub>MIN</sub> to T<sub>MAX</sub>, unless otherwise noted; ≥ +25°C guaranteed by production test, < +25°C guaranteed by design and characterization; typical values are at T<sub>A</sub> = +25°C.)

PARAMETER	SYMBOL	CONDITIONS	MIN	TYP	MAX	UNITS
<b>DC ACCURACY</b>						
Resolution			10			Bits
Integral Nonlinearity	INL	f <sub>IN</sub> = 7.47MHz		±0.75	±3	LSB
Differential Nonlinearity	DNL	f <sub>IN</sub> = 7.47MHz, no missing codes guaranteed	-1.0	±0.4	+1.5	LSB
Offset Error				< ±1	±1.8	%FS
Gain Error				0	±2	%FS
<b>ANALOG INPUT</b>						
Differential Input Voltage Range	V <sub>DIFF</sub>	Differential or single-ended inputs		±1.0		V
Common-Mode Input Voltage Range	V <sub>CM</sub>			V <sub>DD</sub> / 2 ± 0.5		V
Input Resistance	R <sub>IN</sub>	Switched capacitor load		20		kΩ
Input Capacitance	C <sub>IN</sub>			5		pF
<b>CONVERSION RATE</b>						
Maximum Clock Frequency	f <sub>CLK</sub>		120			MHz
Data Latency				5		Clock Cycles
<b>DYNAMIC CHARACTERISTICS</b>						
Signal-to-Noise Ratio	SNR	f <sub>INA</sub> or B = 20.01MHz at -0.5dBFS, T <sub>A</sub> = +25°C	55	58.5		dB
		f <sub>INA</sub> or B = 30.09MHz at -0.5dBFS		58.2		
		f <sub>INA</sub> or B = 59.74MHz at -0.5dBFS		58		
Signal-to-Noise and Distortion	SINAD	f <sub>INA</sub> or B = 20.01MHz at -0.5dBFS, T <sub>A</sub> = +25°C	54.5	57.5		dB
		f <sub>INA</sub> or B = 30.09MHz at -0.5dBFS		57		
		f <sub>INA</sub> or B = 59.74MHz at -0.5dBFS		57		

# Dual 10-Bit, 120Mps, 3.3V, Low-Power ADC with Internal Reference and Parallel Outputs

**MAX1190**

## ELECTRICAL CHARACTERISTICS (continued)

( $V_{DD} = 3.3V$ ;  $OV_{DD} = 2V$ ;  $0.1\mu F$  and  $1.0\mu F$  capacitors from REFP, REFN, and COM to GND, REFOUT connected to REFIN through a  $10k\Omega$  resistor;  $V_{REFIN} = 2.048V$ ;  $V_{IN} = 2V_{P-P}$  (differential with respect to COM);  $C_L = 10pF$  at digital outputs;  $f_{CLK} = 120MHz$ ;  $T_A = T_{MIN}$  to  $T_{MAX}$ , unless otherwise noted;  $\geq +25^\circ C$  guaranteed by production test,  $< +25^\circ C$  guaranteed by design and characterization; typical values are at  $T_A = +25^\circ C$ .)

PARAMETER	SYMBOL	CONDITIONS	MIN	TYP	MAX	UNITS
Spurious-Free Dynamic Range	SFDR	$f_{INA}$ or $B = 20.01MHz$ at $-0.5dBFS$ , $T_A = +25^\circ C$	58	67		dBc
		$f_{INA}$ or $B = 30.09MHz$ at $-0.5dBFS$		67		
		$f_{INA}$ or $B = 59.74MHz$ at $-0.5dBFS$		64		
Third-Harmonic Distortion	HD3	$f_{INA}$ or $B = 20.01MHz$ at $-0.5dBFS$ , $T_A = +25^\circ C$		-67		dBc
		$f_{INA}$ or $B = 30.09MHz$ at $-0.5dBFS$		-67		
		$f_{INA}$ or $B = 59.74MHz$ at $-0.5dBFS$		-64		
Intermodulation Distortion (First Five Odd-Order IMDs)	IMD	$f_{IN1}(A$ or $B) = 43.393MHz$ at $-6.5dBFS$ , $f_{IN2}(A$ or $B) = 48.9017MHz$ at $-6.5dBFS$ (Note 1)		-73		dBc
Third-Order Intermodulation Distortion	IM3	$f_{IN1}(A$ or $B) = 43.393MHz$ at $-6.5dBFS$ , $f_{IN2}(A$ or $B) = 48.9017MHz$ at $-6.5dBFS$ (Note 1)		-83		dBc
Total Harmonic Distortion (First Four Harmonics)	THD	$f_{INA}$ or $B = 20.01MHz$ at $-0.5dBFS$ , $T_A = +25^\circ C$		-65	-58	dBc
		$f_{INA}$ or $B = 30.09MHz$ at $-0.5dBFS$		-65		
		$f_{INA}$ or $B = 59.74MHz$ at $-0.5dBFS$		-63		
Small-Signal Bandwidth		Input at $-20dBFS$ , differential inputs		500		MHz
Full-Power Bandwidth	FPBW	Input at $-0.5dBFS$ , differential inputs		400		MHz
Aperture Delay	$t_{AD}$			1		ns
Aperture Jitter	$t_{AJ}$			2		psRMS
Overdrive Recovery Time		For $1.5\times$ full-scale input		2		ns
<b>INTERNAL REFERENCE</b>						
Reference Output Voltage	$V_{REFOUT}$			2.048	$\pm 3\%$	V
Load Regulation				1.25		mV/mA
Reference Temperature Coefficient	$T_{CREF}$			60		ppm/ $^\circ C$
<b>BUFFERED EXTERNAL REFERENCE (<math>V_{REFIN} = 2.048V</math>)</b>						
Positive Reference Output Voltage	$V_{REFP}$	(Note 2)		2.162		V
Negative Reference Output Voltage	$V_{REFN}$	(Note 2)		1.138		V
Common-Mode Level	$V_{COM}$	(Note 2)		1.651		V
Differential Reference Output Voltage Range	$\Delta V_{REF}$	$\Delta V_{REF} = V_{REFP} - V_{REFN}$	0.95	1.024	1.09	V
REFIN Resistance	$R_{REFIN}$			> 50		$M\Omega$

# Dual 10-Bit, 120MSPS, 3.3V, Low-Power ADC with Internal Reference and Parallel Outputs

## ELECTRICAL CHARACTERISTICS (continued)

( $V_{DD} = 3.3V$ ;  $OV_{DD} = 2V$ ;  $0.1\mu F$  and  $1.0\mu F$  capacitors from REFP, REFN, and COM to GND, REFOUT connected to REFIN through a  $10k\Omega$  resistor;  $V_{REFIN} = 2.048V$ ;  $V_{IN} = 2V_{P-P}$  (differential with respect to COM);  $C_L = 10pF$  at digital outputs;  $f_{CLK} = 120MHz$ ;  $T_A = T_{MIN}$  to  $T_{MAX}$ , unless otherwise noted;  $\geq +25^\circ C$  guaranteed by production test,  $< +25^\circ C$  guaranteed by design and characterization; typical values are at  $T_A = +25^\circ C$ .)

PARAMETER	SYMBOL	CONDITIONS	MIN	TYP	MAX	UNITS
Maximum REFP, COM Source Current	$I_{SOURCE}$			5		mA
Maximum REFP, COM Sink Current	$I_{SINK}$		-250			$\mu A$
Maximum REFN Source Current	$I_{SOURCE}$			250		$\mu A$
Maximum REFN Sink Current	$I_{SINK}$		-5			mA
<b>UNBUFFERED EXTERNAL REFERENCE (<math>V_{REFIN} = AGND</math>, reference voltage applied to REFP, REFN, and COM)</b>						
REFP, REFN Input Resistance	$R_{REFP}, R_{REFN}$	Measured between REFP and COM, and REFN and COM		3.4		$k\Omega$
Differential Reference Input Voltage Range	$\Delta V_{REF}$	$\Delta V_{REF} = V_{REFP} - V_{REFN}$		1.024 $\pm 10\%$		V
COM Input Voltage Range	$V_{COM}$			$V_{DD} / 2 \pm 10\%$		V
REFP Input Voltage	$V_{REFP}$			$V_{COM} + \Delta V_{REF} / 2$		V
REFN Input Voltage	$V_{REFN}$			$V_{COM} - \Delta V_{REF} / 2$		V
<b>DIGITAL INPUTS (CLK, PD, <math>\overline{OE}</math>, SLEEP, T/B)</b>						
Input High Threshold	$V_{IH}$	CLK		$0.8 \times V_{DD}$		V
		PD, $\overline{OE}$ , SLEEP, T/B		$0.8 \times OV_{DD}$		
Input Low Threshold	$V_{IL}$	CLK			$0.2 \times V_{DD}$	V
		PD, $\overline{OE}$ , SLEEP, T/B			$0.2 \times OV_{DD}$	
Input Hysteresis	$V_{HYST}$			0.1		V
Input Leakage	$I_{IH}$	$V_{IH} = V_{DD}$ (CLK)			$\pm 5$	$\mu A$
		$V_{IH} = OV_{DD}$ (PD, $\overline{OE}$ , SLEEP, T/B)			$\pm 5$	
	$I_{IL}$	$V_{IL} = 0$			$\pm 5$	
Input Capacitance	$C_{IN}$			5		pF
<b>DIGITAL OUTPUTS (D9A–D0A, D9B–D0B)</b>						
Output-Voltage Low	$V_{OL}$	$I_{SINK} = -200\mu A$			0.2	V
Output-Voltage High	$V_{OH}$	$I_{SOURCE} = 200\mu A$		$OV_{DD} - 0.2$		V
Three-State Leakage Current	$I_{LEAK}$	$\overline{OE} = OV_{DD}$			$\pm 10$	$\mu A$
Three-State Output Capacitance	$C_{OUT}$	$\overline{OE} = OV_{DD}$		5		pF
<b>POWER REQUIREMENTS</b>						
Analog Supply Voltage Range	$V_{DD}$		3.1	3.3	3.6	V
Output Supply Voltage Range	$OV_{DD}$		1.7	2.5	3.6	V

# Dual 10-Bit, 120Mps, 3.3V, Low-Power ADC with Internal Reference and Parallel Outputs

MAX1190

## ELECTRICAL CHARACTERISTICS (continued)

( $V_{DD} = 3.3V$ ;  $OV_{DD} = 2V$ ;  $0.1\mu F$  and  $1.0\mu F$  capacitors from REFP, REFN, and COM to GND, REFOUT connected to REFIN through a  $10k\Omega$  resistor;  $V_{REFIN} = 2.048V$ ;  $V_{IN} = 2V_{P-P}$  (differential with respect to COM);  $C_L = 10pF$  at digital outputs;  $f_{CLK} = 120MHz$ ;  $T_A = T_{MIN}$  to  $T_{MAX}$ , unless otherwise noted;  $\geq +25^\circ C$  guaranteed by production test,  $< +25^\circ C$  guaranteed by design and characterization; typical values are at  $T_A = +25^\circ C$ .)

PARAMETER	SYMBOL	CONDITIONS	MIN	TYP	MAX	UNITS
Analog Supply Current	$I_{VDD}$	Operating, $f_{INA}$ and B = 20.01MHz at -0.5dBFS		149	185	mA
		Sleep mode		3		
		Shutdown, clock idle, $PD = \overline{OE} = OV_{DD}$		1	15	$\mu A$
Output Supply Current	$I_{OVDD}$	Operating, $f_{INA}$ and B = 20.01MHz at -0.5dBFS; see <i>Typical Operating Characteristics</i> section, Digital Supply Current vs. Analog Input Frequency		16		mA
		Sleep mode		100		
		Shutdown, clock idle, $PD = \overline{OE} = OV_{DD}$		2	10	$\mu A$
Analog Power Dissipation	PDISS	Operating, $f_{INA}$ and B = 20.01MHz at -0.5dBFS		492	611	mW
		Sleep mode		10		
		Shutdown, clock idle, $PD = \overline{OE} = OV_{DD}$		3.3	50	$\mu W$
Power-Supply Rejection Ratio	PSRR	Offset, $V_{DD} \pm 5\%$		$\pm 3.4$		mV/V
		Gain, $V_{DD} \pm 5\%$		$\pm 0.81$		%/V
<b>TIMING CHARACTERISTICS</b>						
CLK Rise to Output Data Valid Time	$t_{DO}$	$C_L = 20pF$ (Note 3)		4.8	7.4	ns
$\overline{OE}$ Fall to Output Enable Time	$t_{ENABLE}$			4.7		ns
$\overline{OE}$ Rise to Output Disable Time	$t_{DISABLE}$			1.2		ns
CLK Pulse-Width High	$t_{CH}$	Clock period: 8.34ns; see <i>Typical Operating Characteristics</i> section, AC Performance vs. Clock Duty Cycle		4.17		ns
CLK Pulse-Width Low	$t_{CL}$	Clock period: 8.34ns; see <i>Typical Operating Characteristics</i> section, AC Performance vs. Clock Duty Cycle		4.17		ns
Wake-Up Time	$t_{WAKE}$	Wake up from sleep mode (Note 4)		0.65		$\mu s$
		Wake up from shutdown mode (Note 4)		1.2		
<b>CHANNEL-TO-CHANNEL MATCHING</b>						
Crosstalk		$f_{INA}$ or B = 20.01MHz at -0.5dBFS		-71		dBc
Gain Matching		$f_{INA}$ or B = 20.01MHz at -0.5dBFS (Note 5)		0.08	$\pm 0.2$	dB
Phase Matching		$f_{INA}$ or B = 20.01MHz at -0.5dBFS (Note 6)		0.8		Degrees

**Note 1:** Intermodulation distortion is the total power of the intermodulation products relative to the total input power.

**Note 2:** REFP, REFN, and COM should be bypassed to GND with a  $0.1\mu F$  (min) or  $1\mu F$  (typ) capacitor.

**Note 3:** Digital outputs settle to  $V_{IH}$ ,  $V_{IL}$ . Parameter guaranteed by design.

**Note 4:** With REFIN driven externally, REFP, COM, and REFN are left floating while powered down.

**Note 5:** Amplitude matching is measured by applying the same signal to each channel and comparing the magnitude of the fundamental of the calculated FFT. The data from both ADC channels must be captured simultaneously during this test.

**Note 6:** Phase matching is measured by applying the same signal to each channel and comparing the phase of the fundamental of the calculated FFT. The data from both ADC channels must be captured simultaneously during this test.

# Dual 10-Bit, 120Mps, 3.3V, Low-Power ADC with Internal Reference and Parallel Outputs

## Typical Operating Characteristics

( $V_{DD} = 3.3V$ ,  $OV_{DD} = 2.5V$ ,  $V_{REFIN} = 2.048V$ , differential input at  $-0.52dBFS$ ,  $f_{CLK} = 120MHz$ ,  $C_L \approx 10pF$ ,  $T_A = +25^\circ C$ , unless otherwise noted.)

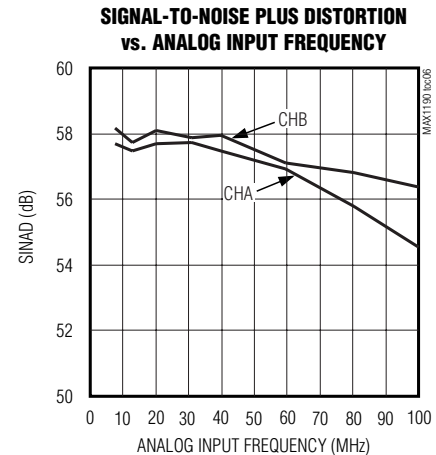
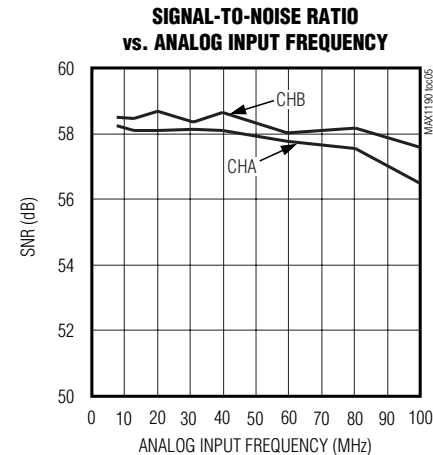
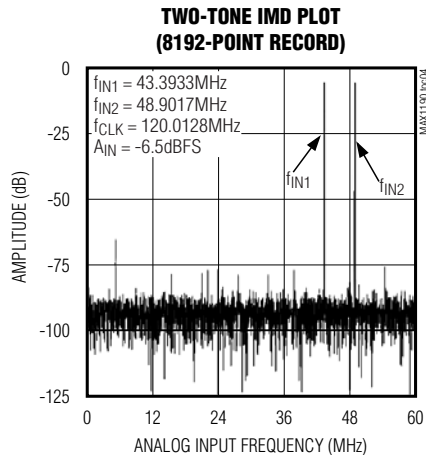
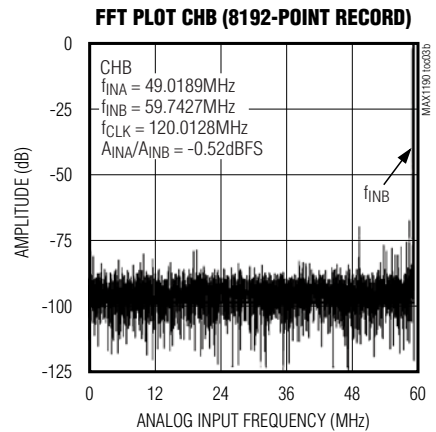
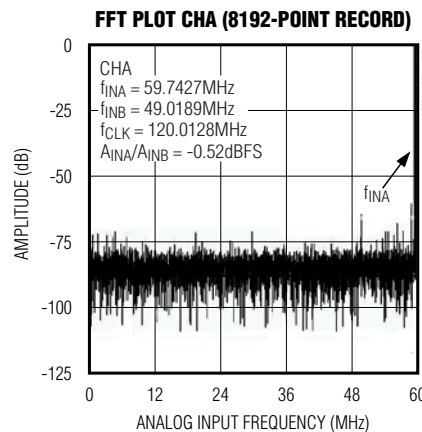
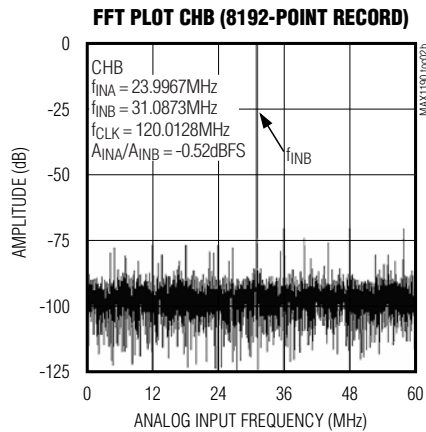
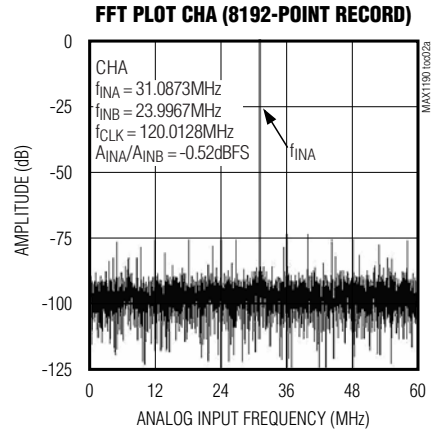
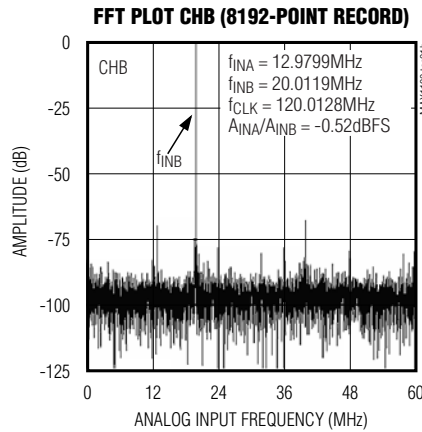
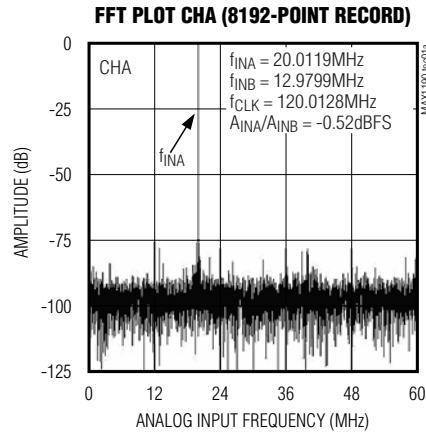

# Dual 10-Bit, 120Mps, 3.3V, Low-Power ADC with Internal Reference and Parallel Outputs

**MAX1190**

## Typical Operating Characteristics (continued)

( $V_{DD} = 3.3V$ ,  $OV_{DD} = 2.5V$ ,  $V_{REFIN} = 2.048V$ , differential input at  $-0.5dBFS$ ,  $f_{CLK} = 120MHz$ ,  $C_L \approx 10pF$ ,  $T_A = +25^\circ C$ , unless otherwise noted.)

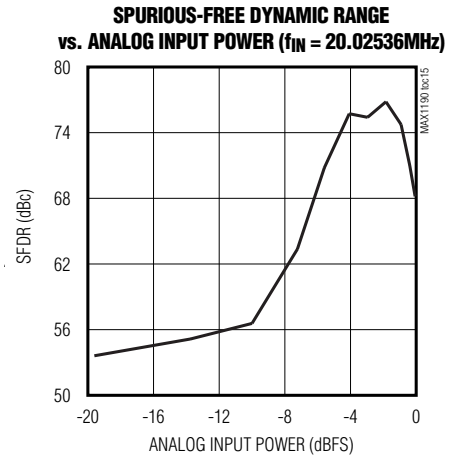
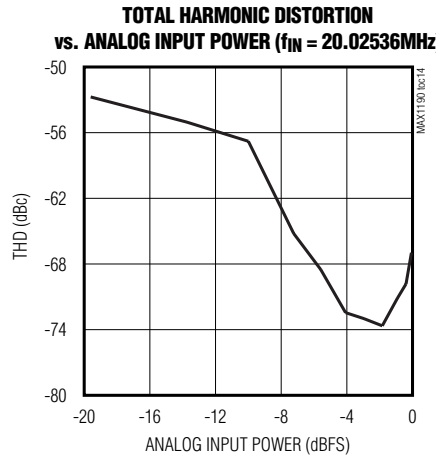
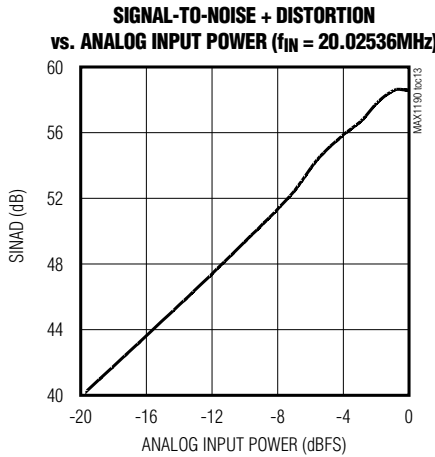
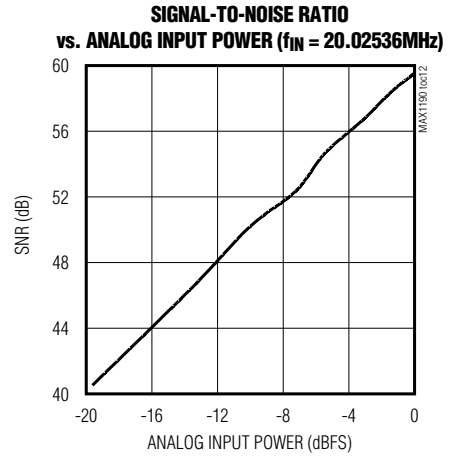
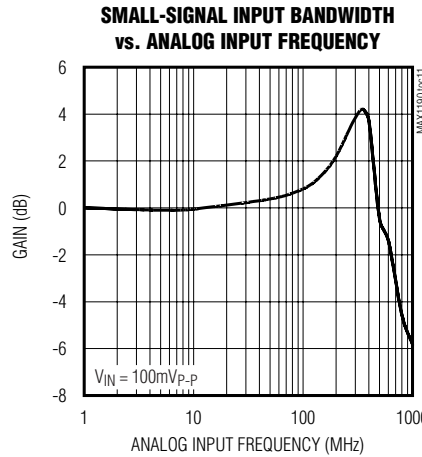
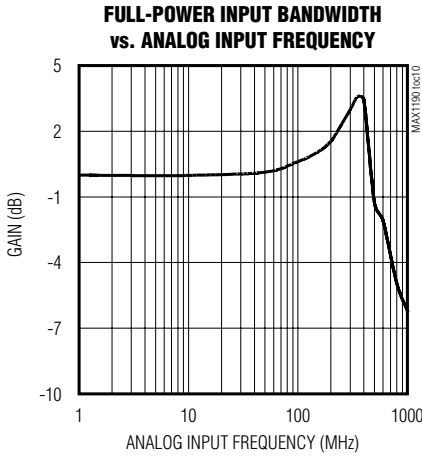
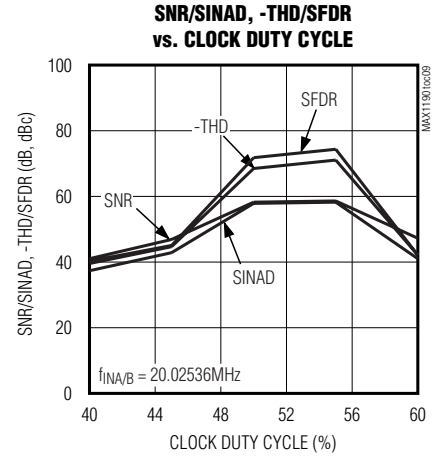
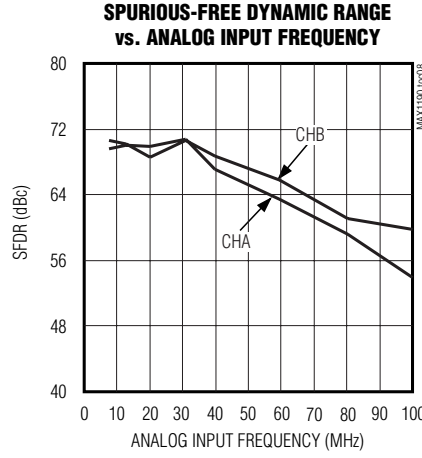
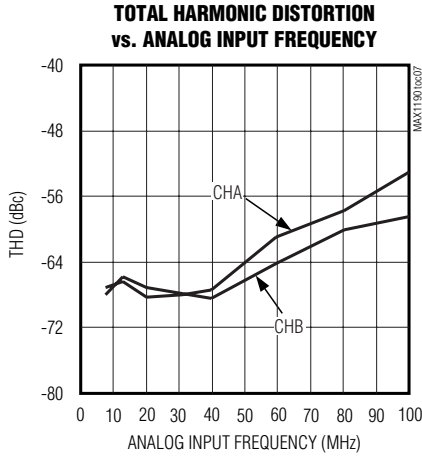

# Dual 10-Bit, 120Mps, 3.3V, Low-Power ADC with Internal Reference and Parallel Outputs

## Typical Operating Characteristics (continued)

( $V_{DD} = 3.3V$ ,  $OV_{DD} = 2.5V$ ,  $V_{REFIN} = 2.048V$ , differential input at  $-0.5dBFS$ ,  $f_{CLK} = 120MHz$ ,  $C_L \approx 10pF$ ,  $T_A = +25^\circ C$ , unless otherwise noted.)

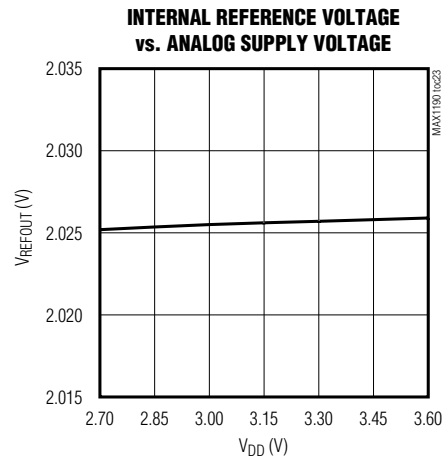
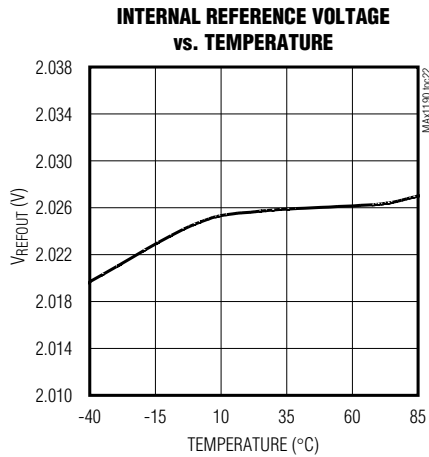
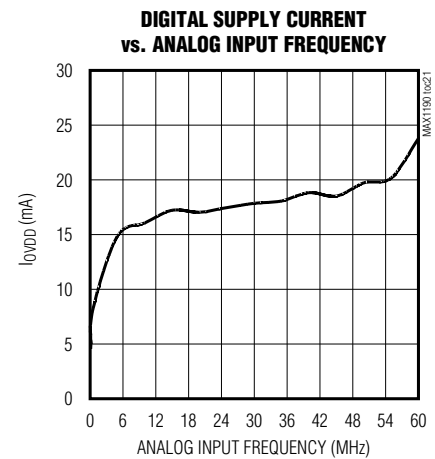
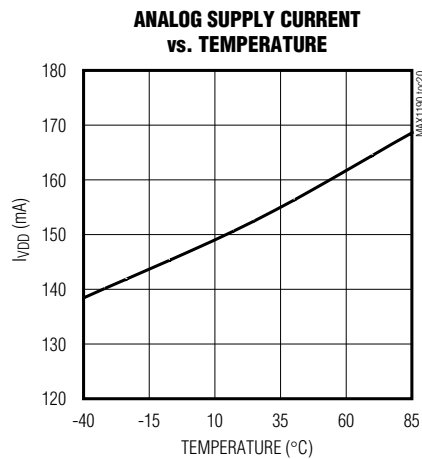
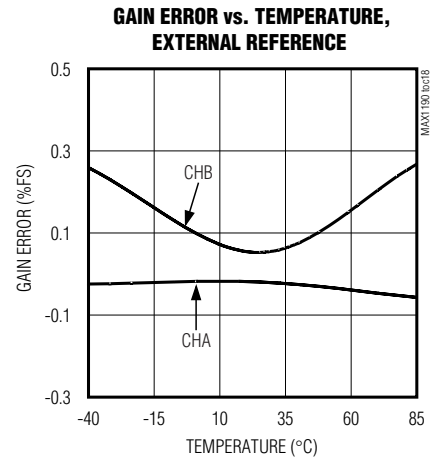
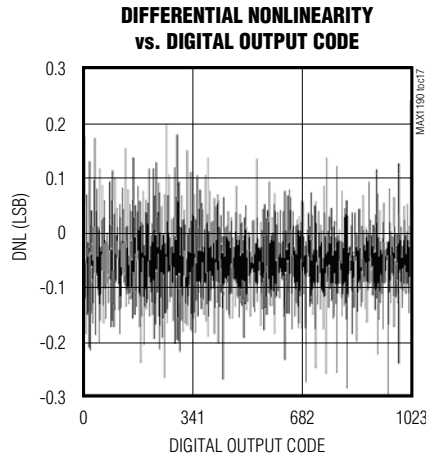
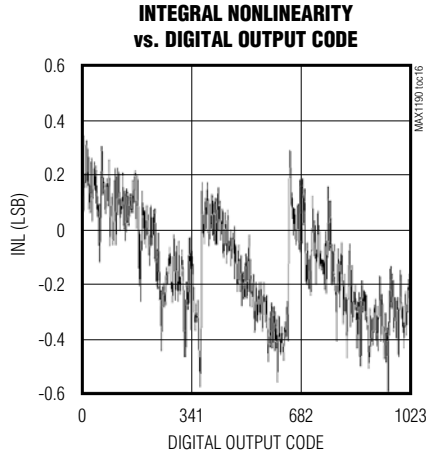

# Dual 10-Bit, 120Mps, 3.3V, Low-Power ADC with Internal Reference and Parallel Outputs

MAX1190

## Typical Operating Characteristics (continued)

( $V_{DD} = 3.3V$ ,  $OV_{DD} = 2.5V$ ,  $V_{REFIN} = 2.048V$ , differential input at  $-0.5dBFS$ ,  $f_{CLK} = 120MHz$ ,  $C_L \approx 10pF$ ,  $T_A = +25^\circ C$ , unless otherwise noted.)

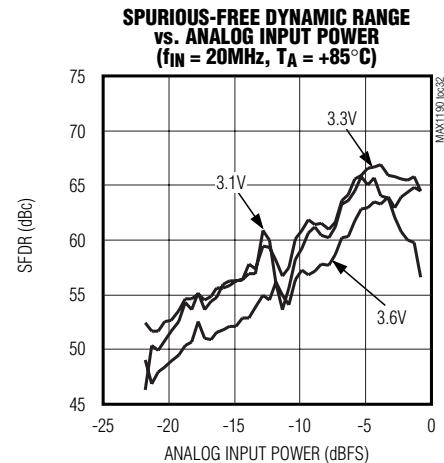
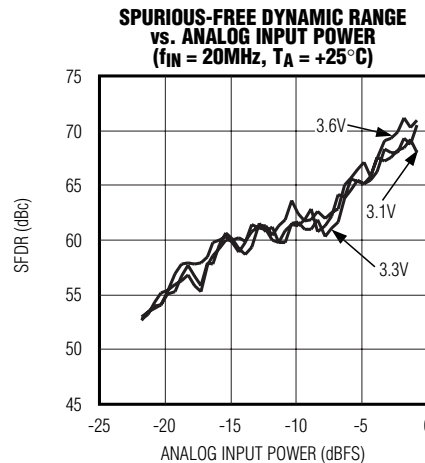
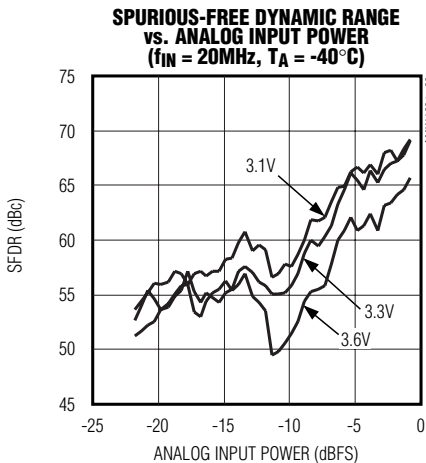
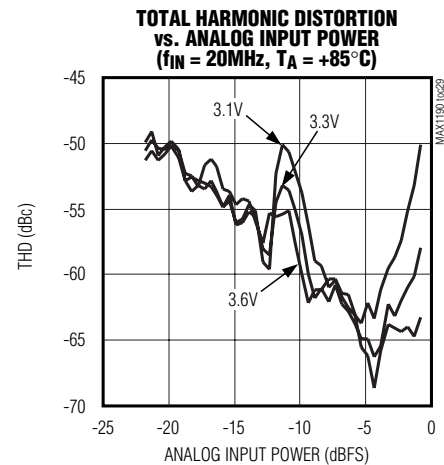
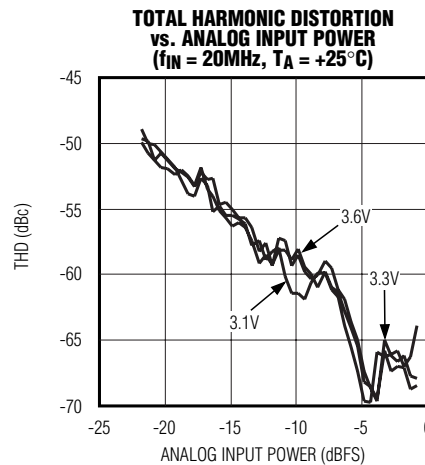
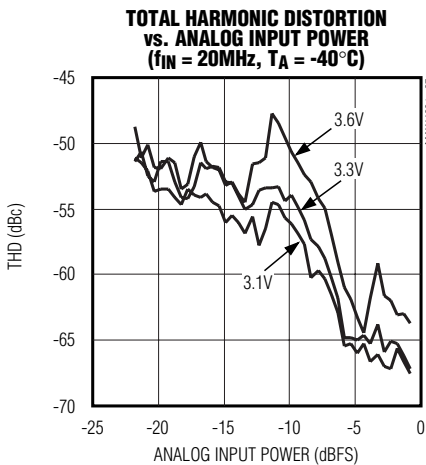
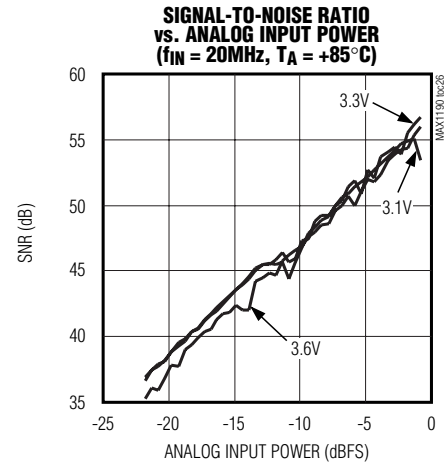
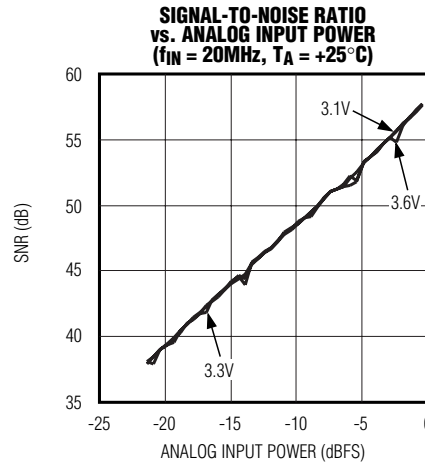
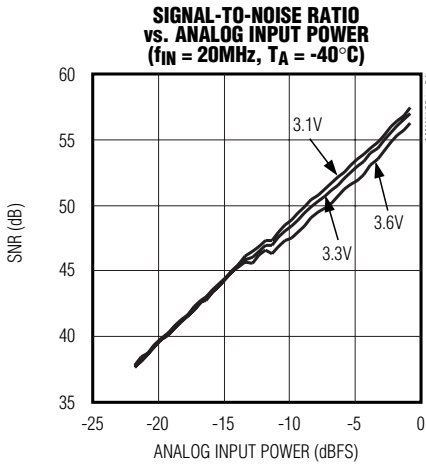

# Dual 10-Bit, 120Mps, 3.3V, Low-Power ADC with Internal Reference and Parallel Outputs

## Pin Description

PIN	NAME	FUNCTION
1	COM	Common-Mode Voltage I/O. Bypass to GND with a $\geq 0.1\mu\text{F}$ capacitor.
2, 6, 11, 14, 15	V <sub>DD</sub>	Analog Supply Voltage. Bypass each supply pin to GND with a $0.1\mu\text{F}$ capacitor. Analog supply accepts a 3.1V to 3.6V input range.
3, 7, 10, 13, 16	GND	Analog Ground
4	INA+	Channel A Positive Analog Input. For single-ended operation, connect signal source to INA+.
5	INA-	Channel A Negative Analog Input. For single-ended operation, connect INA- to COM.
8	INB-	Channel B Negative Analog Input. For single-ended operation, connect INB- to COM.
9	INB+	Channel B Positive Analog Input. For single-ended operation, connect signal source to INB+.
12	CLK	Converter Clock Input
17	T/B	T/B selects the ADC Digital Output Format: High: Two's complement Low: Straight offset binary
18	SLEEP	Sleep-Mode Input: High: Disables both quantizers, but leaves the reference bias circuit active Low: Normal operation
19	PD	High-Active Power-Down Input: High: Power-down mode Low: Normal operation
20	$\overline{\text{OE}}$	Low-Active Output Enable Input: High: Digital outputs disabled Low: Digital outputs enabled
21	D9B	Three-State Digital Output, Bit 9 (MSB), Channel B
22	D8B	Three-State Digital Output, Bit 8, Channel B
23	D7B	Three-State Digital Output, Bit 7, Channel B
24	D6B	Three-State Digital Output, Bit 6, Channel B
25	D5B	Three-State Digital Output, Bit 5, Channel B
26	D4B	Three-State Digital Output, Bit 4, Channel B
27	D3B	Three-State Digital Output, Bit 3, Channel B
28	D2B	Three-State Digital Output, Bit 2, Channel B
29	D1B	Three-State Digital Output, Bit 1, Channel B
30	D0B	Three-State Digital Output, Bit 0, Channel B
31, 34	OGND	Output Driver Ground
32, 33	OV <sub>DD</sub>	Output Driver Supply Voltage. Bypass each supply pin to OGND with a $0.1\mu\text{F}$ capacitor. Output driver supply accepts a 1.7V to 3.6V input range.
35	D0A	Three-State Digital Output, Bit 0, Channel A
36	D1A	Three-State Digital Output, Bit 1, Channel A
37	D2A	Three-State Digital Output, Bit 2, Channel A
38	D3A	Three-State Digital Output, Bit 3, Channel A
39	D4A	Three-State Digital Output, Bit 4, Channel A

# Dual 10-Bit, 120Mps, 3.3V, Low-Power ADC with Internal Reference and Parallel Outputs

## Pin Description (continued)

PIN	NAME	FUNCTION
40	D5A	Three-State Digital Output, Bit 5, Channel A
41	D6A	Three-State Digital Output, Bit 6, Channel A
42	D7A	Three-State Digital Output, Bit 7, Channel A
43	D8A	Three-State Digital Output, Bit 8, Channel A
44	D9A	Three-State Digital Output, Bit 9 (MSB), Channel A
45	REFOUT	Internal Reference Voltage Output. Can be connected to REFIN through a resistor or a resistor-divider.
46	REFIN	Reference Input. $V_{REFIN} = 2 \times (V_{REFP} - V_{REFN})$ . Bypass to GND with a $> 0.1\mu\text{F}$ capacitor.
47	REFP	Positive Reference I/O. Conversion range is $\pm(V_{REFP} - V_{REFN})$ . Bypass to GND with a $> 0.1\mu\text{F}$ capacitor.
48	REFN	Negative Reference I/O. Conversion range is $\pm(V_{REFP} - V_{REFN})$ . Bypass to GND with a $> 0.1\mu\text{F}$ capacitor.
—	EP	Exposed Paddle. Connect to analog ground.

## Detailed Description

The MAX1190 uses a nine-stage, fully differential, pipelined architecture (Figure 1) that allows for high-speed conversion while minimizing power consumption. Samples taken at the inputs move progressively through the pipeline stages every half-clock cycle. Including the delay through the output latch, the total clock-cycle latency is five clock cycles.

Flash ADCs convert the held input voltages into a digital code. Internal MDACs convert the digitized results back into analog voltages, which are then subtracted from the original held input signals. The resulting error signals are then multiplied by 2, and the residues are passed along to the next pipeline stages, where the process is repeated until the signals have been processed by all nine stages.

## Input Track-and-Hold Circuits

Figure 2 displays a simplified functional diagram of the input T/H circuits in both track and hold mode. In track mode, switches S1, S2a, S2b, S4a, S4b, S5a, and S5b are closed. The fully differential circuits sample the input signals onto the two capacitors (C2a and C2b) through switches S4a and S4b. S2a and S2b set the common mode for the amplifier input, and open simultaneously with S1, sampling the input waveform. Switches S4a, S4b, S5a, and S5b are then opened before switches S3a and S3b connect capacitors C1a and C1b to the output of the amplifier and switch S4c is closed. The resulting differential voltages are held on capacitors C2a and C2b. The amplifiers are used to charge capacitors C1a and C1b to the same values originally held on C2a and C2b.

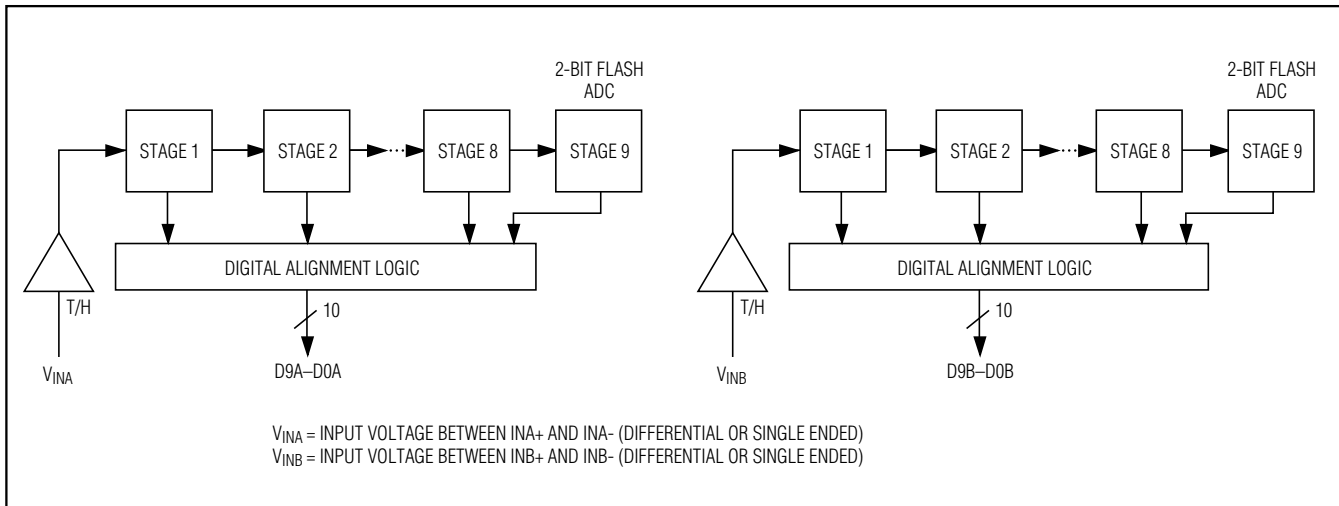

Figure 1. Pipelined Architecture—Stage Blocks

# Dual 10-Bit, 120Mps, 3.3V, Low-Power ADC with Internal Reference and Parallel Outputs

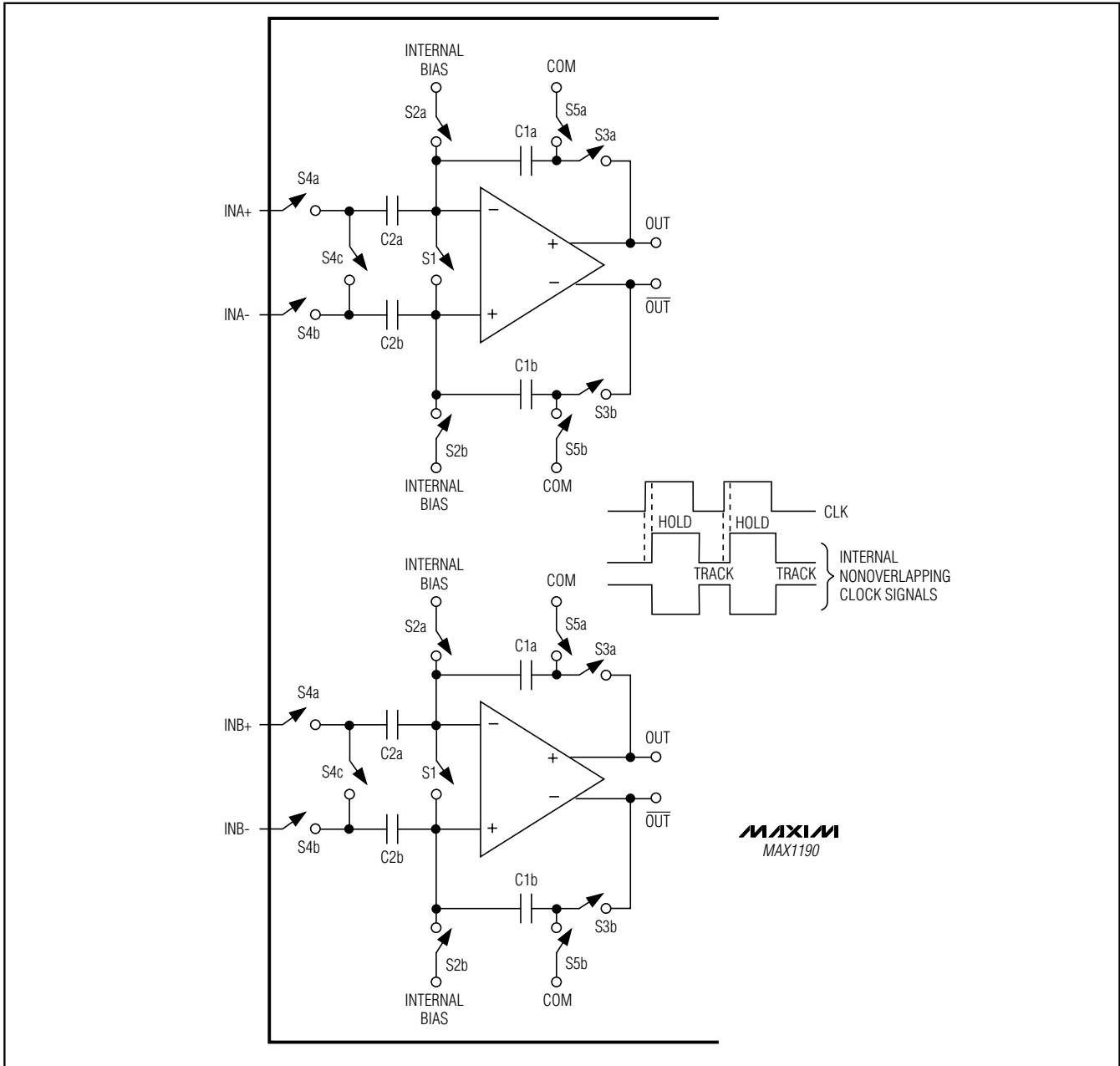

Figure 2. MAX1190 T/H Amplifiers

These values are then presented to the first-stage quantizers and isolate the pipelines from the fast-changing inputs. The wide input bandwidth T/H amplifiers allow the MAX1190 to track and sample/hold analog inputs of high frequencies ( $> N_{yquist}$ ). Both ADC inputs (INA+, INB+,

INA- and INB-) can be driven either differentially or single ended. Match the impedance of INA+ and INA-, as well as INB+ and INB-, and set the common-mode voltage to midsupply ( $V_{DD} / 2$ ) for optimum performance.

# Dual 10-Bit, 120Mps, 3.3V, Low-Power ADC with Internal Reference and Parallel Outputs

## Analog Inputs and Reference Configurations

The full-scale range of the MAX1190 is determined by the internally generated voltage difference between REFP ( $V_{DD} / 2 + V_{REFIN} / 4$ ) and REFN ( $V_{DD} / 2 - V_{REFIN} / 4$ ). The full-scale range for both on-chip ADCs is adjustable through the REFIN pin, which is provided for this purpose.

The MAX1190 provides three modes of reference operation:

- Internal reference mode
- Buffered external reference mode
- Unbuffered external reference mode

In internal reference mode, connect the internal reference output REFOUT to REFIN through a resistor (e.g., 10kΩ) or resistor-divider, if an application requires a reduced full-scale range. For stability and noise filtering purposes, bypass REFIN with a > 10nF capacitor to GND. In internal reference mode, REFOUT, COM, REFP, and REFN become low-impedance outputs.

In buffered external reference mode, adjust the reference voltage levels externally by applying a stable and accurate voltage at REFIN. In this mode, COM, REFP, and REFN are outputs. REFOUT can be left open or connected to REFIN through a > 10kΩ resistor.

In unbuffered external reference mode, connect REFIN to GND. This deactivates the on-chip reference buffers for REFP, COM, and REFN. With their buffers shut down,

these nodes become high-impedance inputs and can be driven through separate, external reference sources.

For detailed circuit suggestions and how to drive this dual ADC in buffered/unbuffered external reference mode, see the *Applications Information* section.

## Clock Input (CLK)

The MAX1190's CLK input accepts a CMOS-compatible clock signal. Since the interstage conversion of the device depends on the repeatability of the rising and falling edges of the external clock, use a clock with low jitter and fast rise and fall times (< 2ns). In particular, sampling occurs on the rising edge of the clock signal, requiring this edge to provide the lowest possible jitter. Any significant aperture jitter would limit the SNR performance of the on-chip ADCs as follows:

$$SNR = 20 \times \log \left( \frac{1}{2 \times \pi \times f_{IN} \times t_{AJ}} \right)$$

where  $f_{IN}$  represents the analog input frequency and  $t_{AJ}$  is the time of the aperture jitter. Clock jitter is especially critical for undersampling applications. The clock input should always be considered as an analog input and routed away from any analog input or other digital signal lines. The MAX1190 clock input operates with a voltage threshold set to  $V_{DD} / 2$ . Clock inputs with a duty cycle other than 50%, must meet the specifications for high and low periods as stated in the *Electrical Characteristics*.

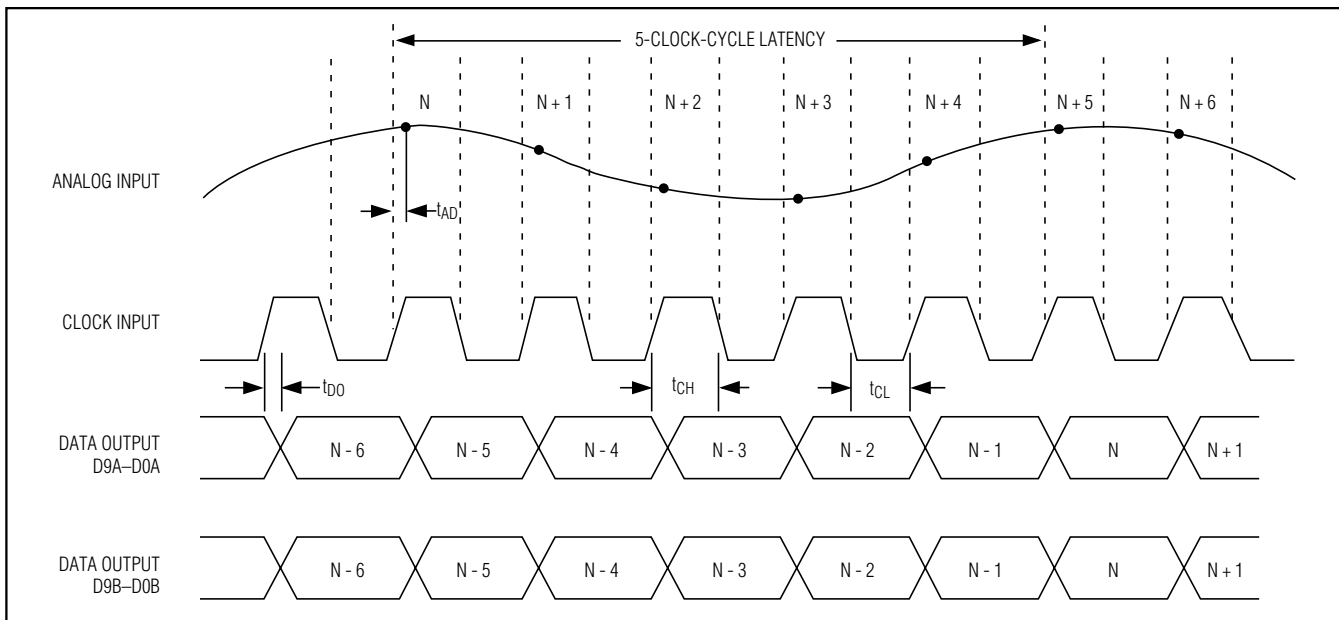

Figure 3. System Timing Diagram

# Dual 10-Bit, 120MSPs, 3.3V, Low-Power ADC with Internal Reference and Parallel Outputs

## System Timing Requirements

Figure 3 depicts the relationship between the clock input, analog input, and data output. The MAX1190 samples at the rising edge of the input clock. Output data for channels A and B is valid on the next rising edge of the input clock. The output data has an internal latency of five clock cycles. Figure 3 also determines the relationship between the input clock parameters and the valid output data on channels A and B.

## Digital Output Data (D0A/B–D9A/B), Output Data Format Selection (T/B), Output Enable (OE)

All digital outputs, D0A–D9A (channel A) and D0B–D9B (channel B), are TTL/CMOS-logic compatible. There is a five-clock-cycle latency between any particular sample and its corresponding output data. The output coding can be chosen to be either straight offset binary or two's complement (Table 1) controlled by a single pin (T/B). Pull T/B low to select offset binary and high to activate two's complement output coding. The capacitive load on digital outputs D0A–D9A and D0B–D9B should be kept as low as possible (< 15pF) to avoid large digital currents that could feed back into the analog portion of the MAX1190, thereby degrading its dynamic performance. Using buffers on the digital outputs of the ADCs can further isolate the digital outputs from heavy capacitive loads. To further improve the dynamic performance of the MAX1190, small series resistors (e.g., 100Ω) can be added to the digital output paths, close to the MAX1190.

Figure 4 displays the timing relationship between output enable and data output valid, as well as power-down/wakeup and data output valid.

## Power-Down (PD) and Sleep (SLEEP) Modes

The MAX1190 offers two power-save modes—sleep mode and full power-down mode. In sleep mode

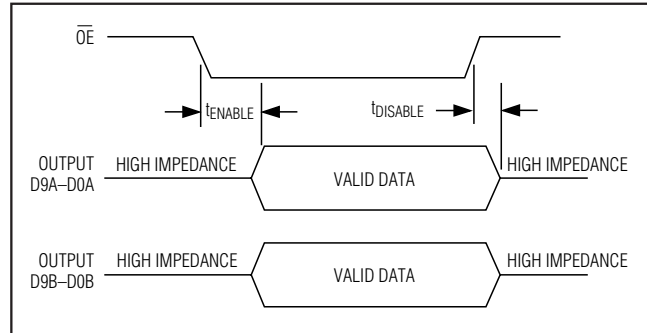

Figure 4. Output Timing Diagram

(SLEEP = 1), only the reference bias circuit is active (both ADCs are disabled), and current consumption is reduced to 3mA.

To enter full power-down mode, pull PD high. With OE simultaneously low, all outputs are latched at the last value prior to the power down. Pulling OE high forces the digital outputs into a high-impedance state.

## Applications Information

Figure 5 depicts a typical application circuit containing two single-ended to differential converters. The internal reference provides a  $V_{DD} / 2$  output voltage for level-shifting purposes. The input is buffered and then split to a voltage follower and inverter. One lowpass filter per amplifier suppresses some of the wideband noise associated with high-speed operational amplifiers. The user can select the  $R_{ISO}$  and  $C_{IN}$  values to optimize the filter performance to suit a particular application. For the application in Figure 5, a  $R_{ISO}$  of 50Ω is placed before the capacitive load to prevent ringing and oscillation. The 22pF  $C_{IN}$  capacitor acts as a small filter capacitor.

Table 1. MAX1190 Output Codes For Differential Inputs

DIFFERENTIAL INPUT VOLTAGE*	DIFFERENTIAL INPUT	STRAIGHT OFFSET BINARY T/B = 0	TWO'S COMPLEMENT T/B = 1
$V_{REF} \times 512/512$	+FULL SCALE - 1 LSB	11 1111 1111	01 1111 1111
$V_{REF} \times 1/512$	+1 LSB	10 0000 0001	00 0000 0001
0	Bipolar Zero	10 0000 0000	00 0000 0000
$-V_{REF} \times 1/512$	-1 LSB	01 1111 1111	11 1111 1111
$-V_{REF} \times 511/512$	-FULL SCALE + 1 LSB	00 0000 0001	10 0000 0001
$-V_{REF} \times 512/512$	-FULL SCALE	00 0000 0000	10 0000 0000

\* $V_{REF} = V_{REFP} - V_{REFN}$

# Dual 10-Bit, 120Mps, 3.3V, Low-Power ADC with Internal Reference and Parallel Outputs

**MAX1190**

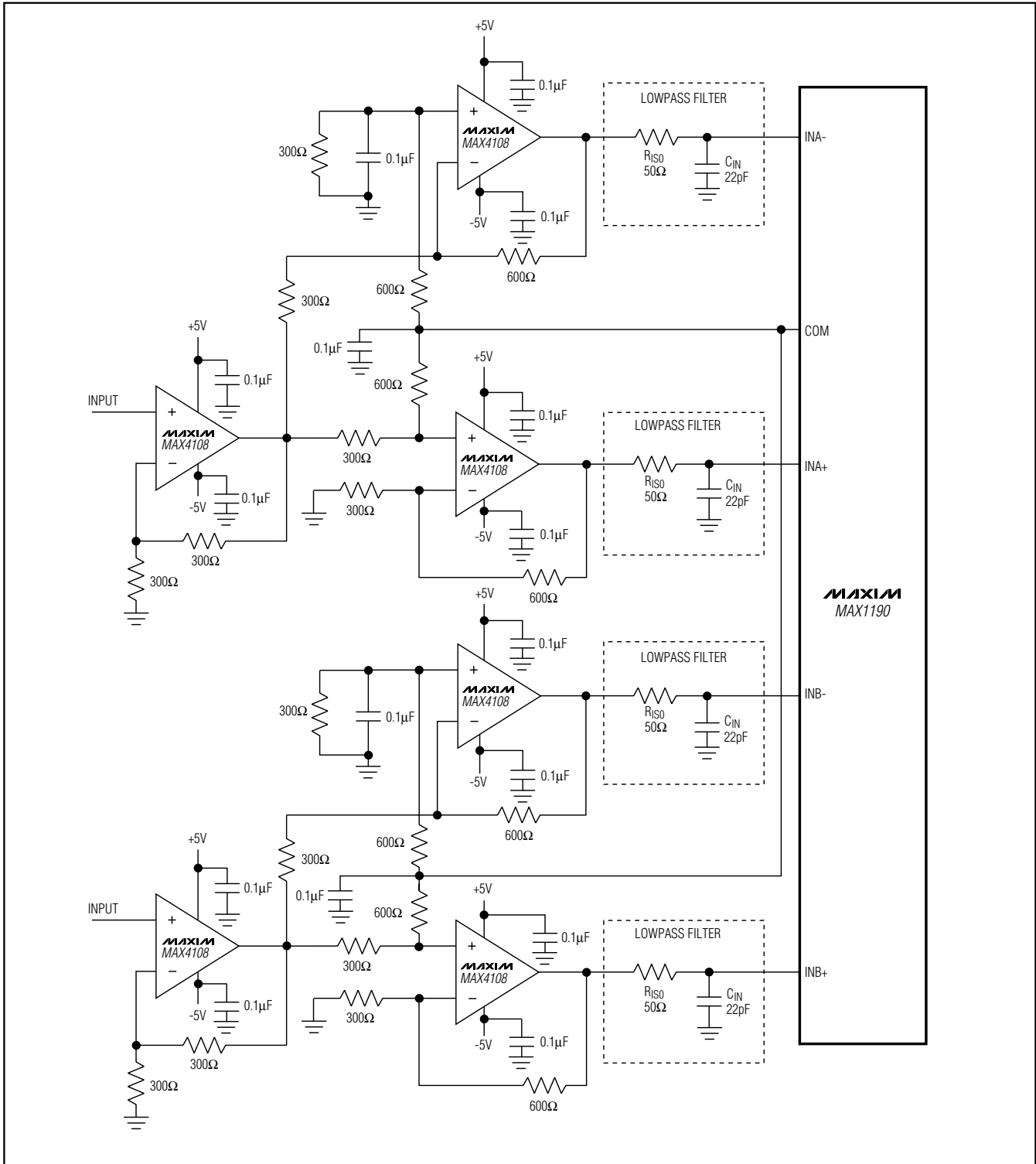

Figure 5. Typical Application for Single-Ended-to-Differential Conversion

# Dual 10-Bit, 120MSPs, 3.3V, Low-Power ADC with Internal Reference and Parallel Outputs

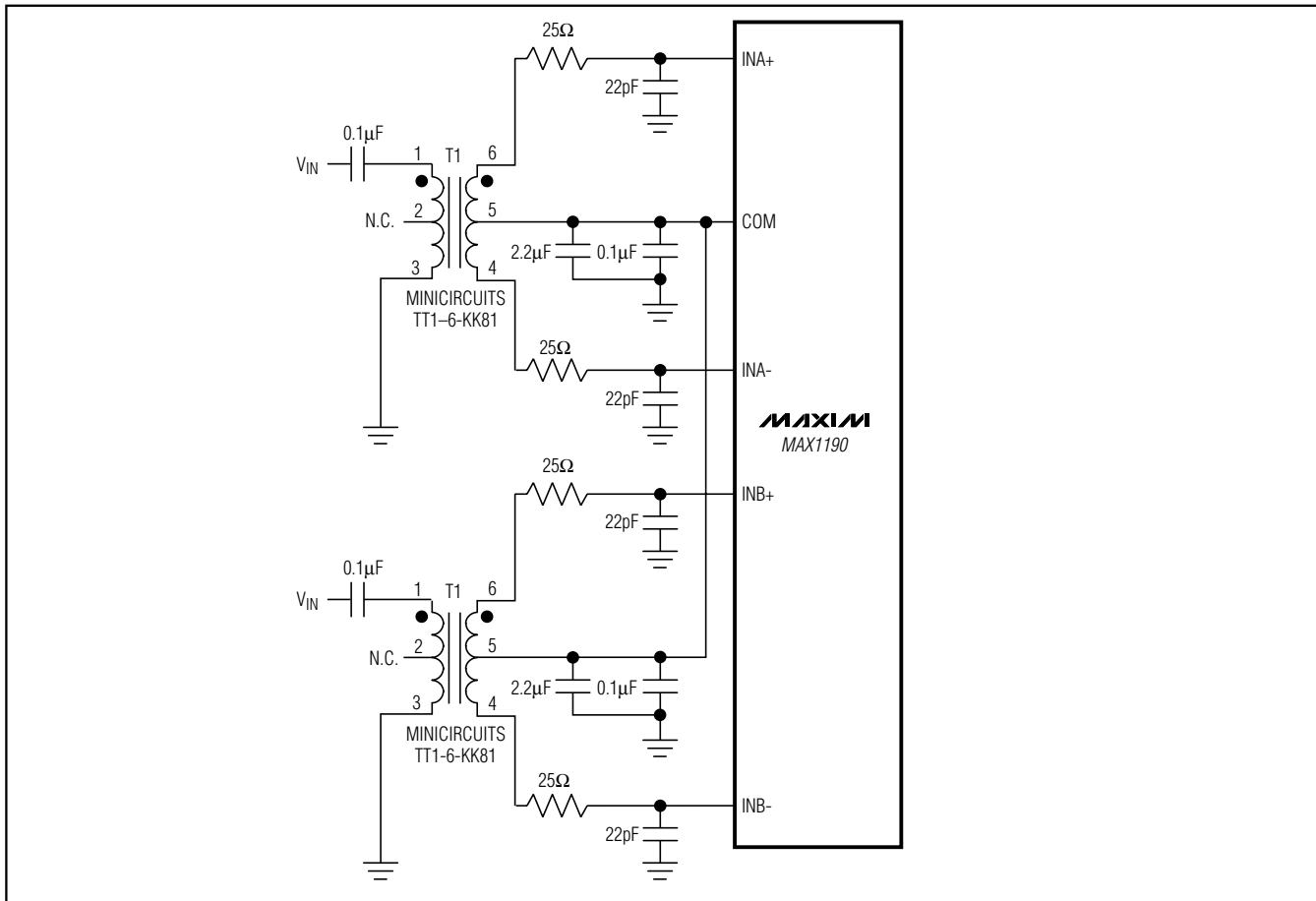

Figure 6. Transformer-Coupled Input Drive

### Using Transformer Coupling

An RF transformer (Figure 6) provides an excellent solution to convert a single-ended source signal to a fully differential signal, required by the MAX1190 for optimum performance. Connecting the center tap of the transformer to COM provides a  $V_{DD} / 2$  DC level shift to the input. Although a 1:1 transformer is shown, a step-up transformer can be selected to reduce the drive requirements. A reduced signal swing from the input driver, such as an op amp, can also improve the overall distortion.

In general, the MAX1190 provides better SFDR and THD with fully differential input signals than single-ended drive, especially for very high input frequencies. In differential input mode, even-order harmonics are lower as both inputs (INA+, INA- and/or INB+, INB-) are balanced, and each of the ADC inputs only requires half the signal swing compared to single-ended mode.

### Single-Ended AC-Coupled Input Signal

Figure 7 shows an AC-coupled, single-ended application. Amplifiers like the MAX4108 provide high speed, high bandwidth, low noise, and low distortion to maintain the integrity of the input signal.

### Buffered External Reference Drives Multiple ADCs

Multiple-converter systems based on the MAX1190 are well suited for use with a common reference voltage. The REFIN pin of those converters can be connected directly to an external reference source.

A precision bandgap reference like the MAX6062 generates an external DC level of 2.048V (Figure 8), and exhibits a noise voltage density of 150nV/√Hz. Its output passes through a 1-pole lowpass filter (with 10Hz cutoff frequency) to the MAX4250, which buffers the reference before its output is applied to a second 10Hz lowpass filter. The MAX4250 provides a low offset voltage (for

# Dual 10-Bit, 120Mps, 3.3V, Low-Power ADC with Internal Reference and Parallel Outputs

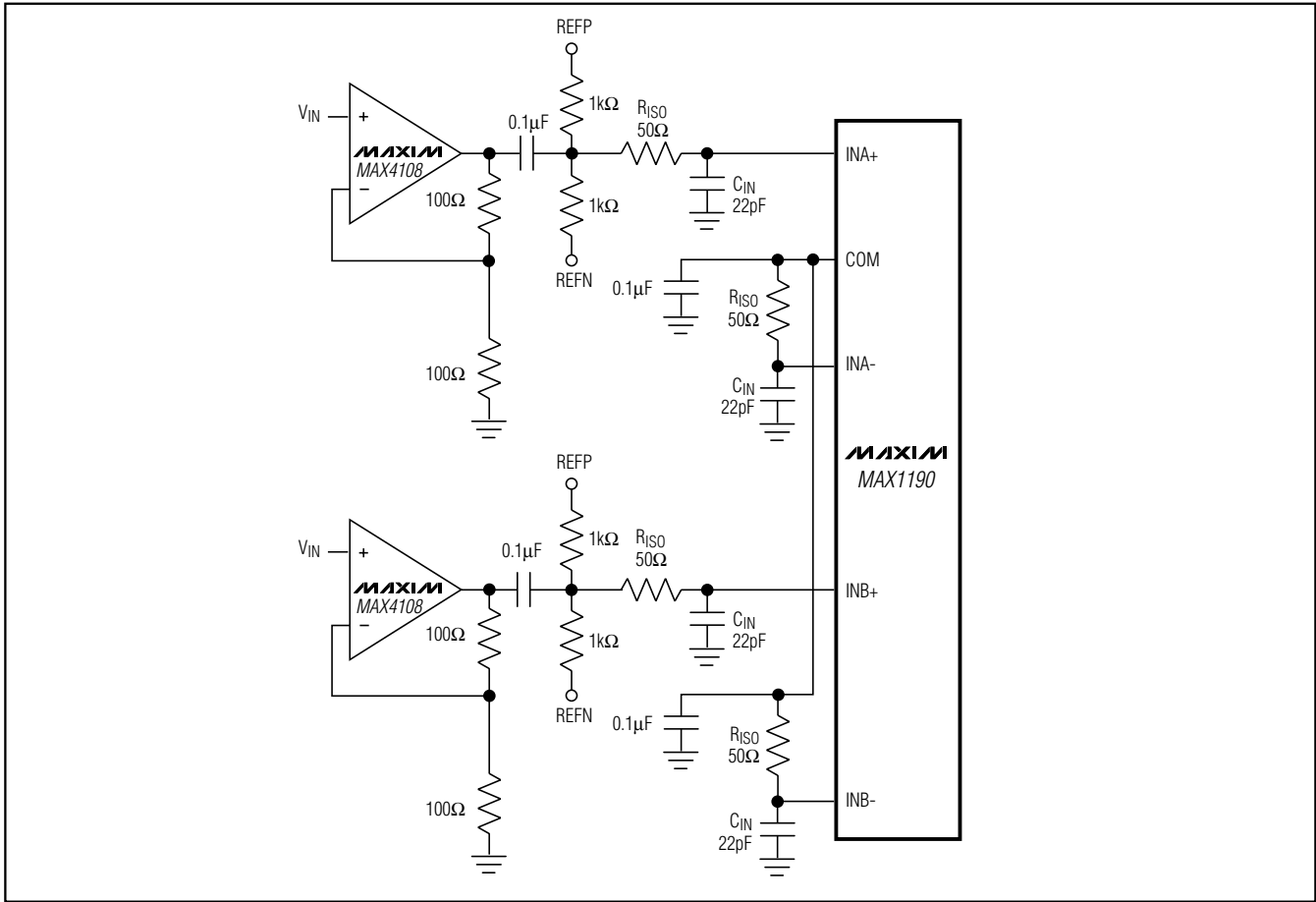

Figure 7. Using an Op Amp for Single-Ended, AC-Coupled Input Drive

high-gain accuracy) and a low noise level. The passive 10Hz filter following the buffer attenuates noise produced in the voltage reference and buffer stages. This filtered noise density, which decreases for higher frequencies, meets the noise levels specified for precision-ADC operation.

### Unbuffered External Reference Drives Multiple ADCs

Connecting each REF<sub>IN</sub> to analog ground disables the internal reference of each device, allowing the internal reference ladders to be driven directly by a set of external reference sources. Followed by a 10Hz lowpass filter and precision voltage-divider, the MAX6066 generates a DC level of 2.500V. The buffered outputs of this divider are set to 2.0V, 1.5V, and 1.0V, with an accuracy that depends on the tolerance of the divider resistors (Figure 9).

Those three voltages are buffered by the MAX4252, which provides low noise and low DC offset. The individual voltage followers are connected to 10Hz lowpass filters, which filter both the reference voltage and amplifier noise to a level of  $3\text{nV}/\sqrt{\text{Hz}}$ . The 2.0V and 1.0V reference voltages set the differential full-scale range of the associated ADCs at 2V<sub>P-P</sub>. The 2.0V and 1.0V buffers drive the ADCs' internal ladder resistances between them. Note that the common power supply for all active components removes any concern regarding power-supply sequencing when powering up or down.

With the outputs of the MAX4252 matching better than 0.1%, the buffers and subsequent lowpass filters can be replicated to support as many as 32 ADCs. For applications that require more than 32 matched ADCs, a voltage reference and divider string common to all converters is highly recommended.



# Dual 10-Bit, 120Mps, 3.3V, Low-Power ADC with Internal Reference and Parallel Outputs

**MAX1190**

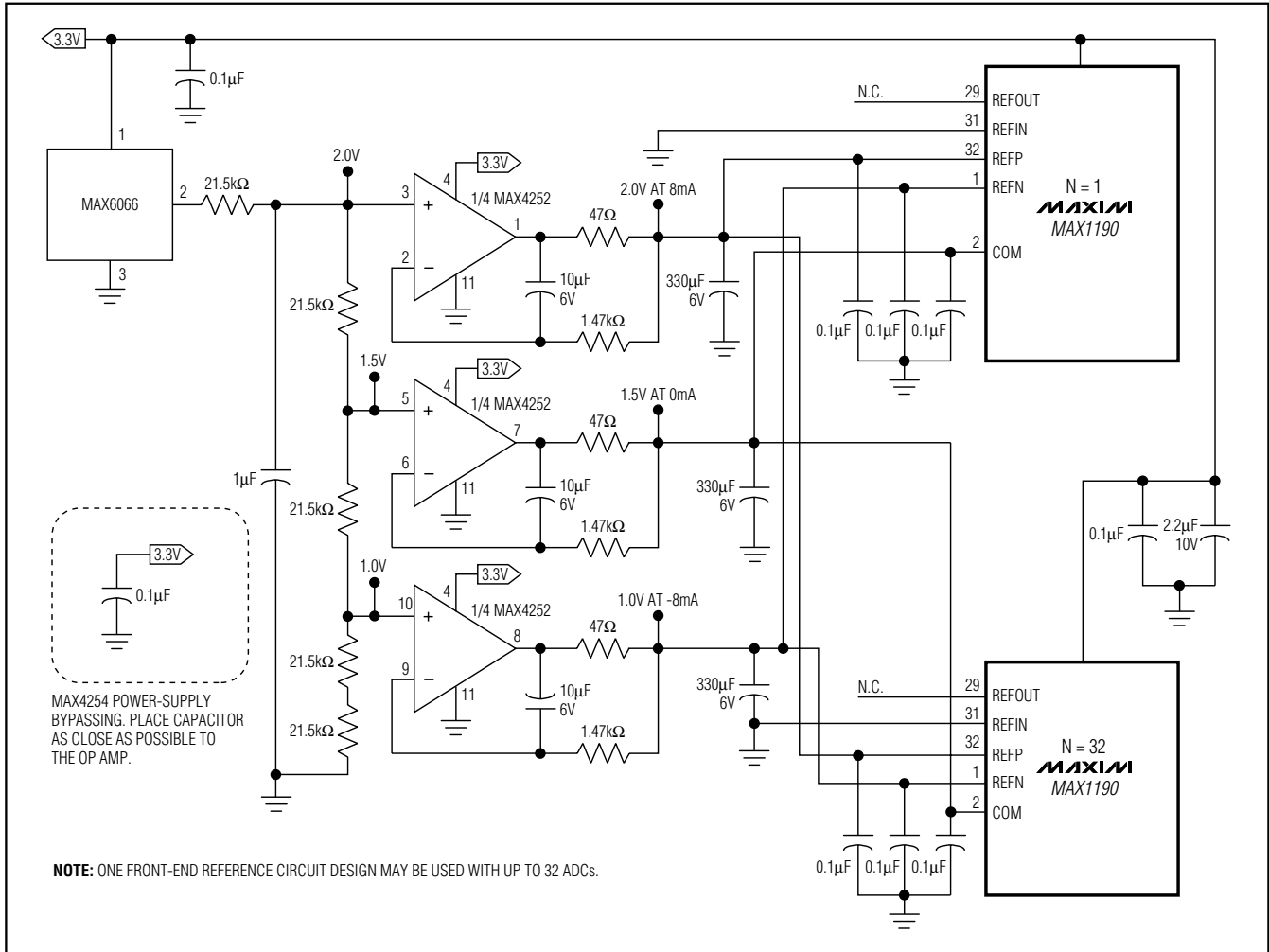

Figure 9. External Unbuffered Reference Drive with MAX4252 and MAX6066

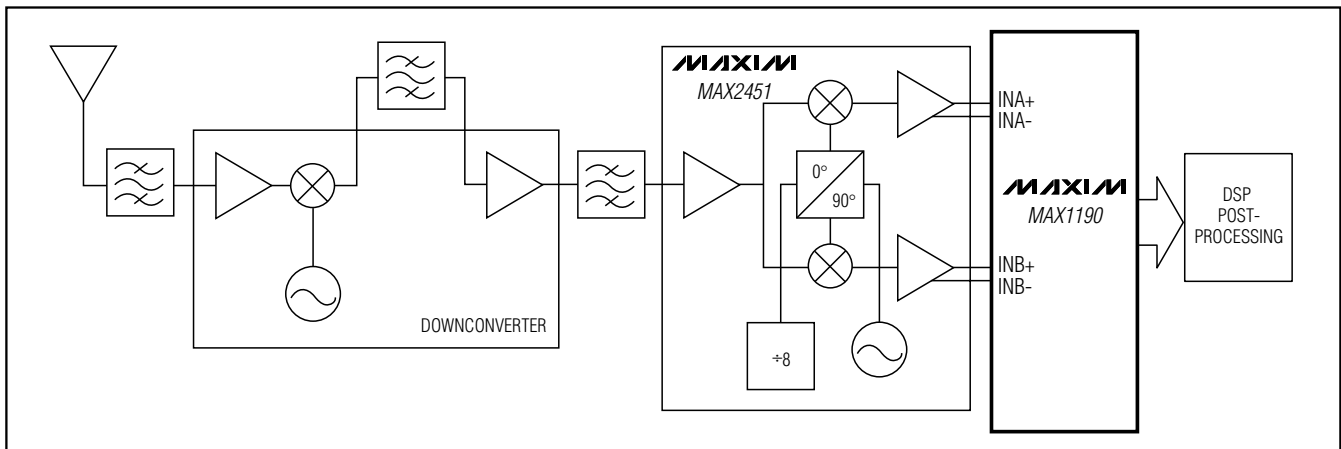

Figure 10. Typical QAM Application Using the MAX1190

# Dual 10-Bit, 120MSPS, 3.3V, Low-Power ADC with Internal Reference and Parallel Outputs

## Grounding, Bypassing, and Board Layout

The MAX1190 requires high-speed board layout design techniques. Locate all bypass capacitors as close to the device as possible, preferably on the same side as the ADC, using surface-mount devices for minimum inductance. Bypass  $V_{DD}$ , REFP, REFN, and COM with two parallel 0.1 $\mu$ F ceramic capacitors and a 2.2 $\mu$ F bipolar capacitor to GND. Follow the same rules to bypass the digital supply ( $OV_{DD}$ ) to OGND. Multilayer boards with separated ground and power planes produce the highest level of signal integrity. Consider the use of a split ground plane arranged to match the physical location of the analog ground (GND) and the digital output driver ground (OGND) on the ADC's package. The two ground planes should be joined at a single point such that the noisy digital ground currents do not interfere with the analog ground plane. The ideal location of this connection can be determined experimentally at a point along the gap between the two ground planes, which produces optimum results. Make this connection with a low-value, surface-mount resistor (1 $\Omega$  to 5 $\Omega$ ), a ferrite bead, or a direct short. Alternatively, all ground pins could share the same ground plane if the ground plane is sufficiently isolated from any noisy, digital systems ground plane (e.g., downstream output buffer or DSP ground plane). Route high-speed digital signal traces away from the sensitive analog traces of either channel. Make sure to isolate the analog input lines to each respective converter to minimize channel-to-channel crosstalk. Keep all signal lines short and free of 90° turns.

## Static Parameter Definitions

### Integral Nonlinearity (INL)

Integral nonlinearity is the deviation of the values on an actual transfer function from a straight line. This straight

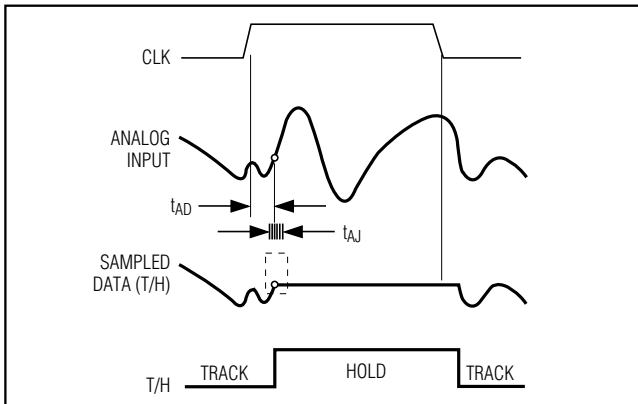

Figure 11. T/H Aperture Timing

line can be either a best-straight-line fit or a line drawn between the endpoints of the transfer function, once offset and gain errors have been nullified. The static linearity parameters for the MAX1190 are measured using the best-straight-line fit method.

### Differential Nonlinearity (DNL)

Differential nonlinearity is the difference between an actual step width and the ideal value of 1 LSB. A DNL error specification of less than 1 LSB guarantees no missing codes and a monotonic transfer function.

## Dynamic Parameter Definitions

### Aperture Jitter

Figure 11 depicts the aperture jitter ( $t_{AJ}$ ), which is the sample-to-sample variation in the aperture delay.

### Aperture Delay

Aperture delay ( $t_{AD}$ ) is the time defined between the falling edge of the sampling clock and the instant when an actual sample is taken (Figure 11).

### Signal-to-Noise Ratio (SNR)

For a waveform perfectly reconstructed from digital samples, the theoretical maximum SNR is the ratio of the full-scale analog input (RMS value) to the RMS quantization error (residual error). The ideal, theoretical minimum analog-to-digital noise is caused by quantization error only and results directly from the ADC's resolution (N bits):

$$\text{SNR}_{\text{dB}[\text{max}]} = 6.02\text{dB} \times N + 1.76\text{dB}$$

In reality, there are other noise sources besides quantization noise: thermal noise, reference noise, clock jitter, etc. SNR is computed by taking the ratio of the RMS signal to the RMS noise, which includes all spectral components minus the fundamental, the first five harmonics, and the DC offset.

### Signal-to-Noise Plus Distortion (SINAD)

SINAD is computed by taking the ratio of the RMS signal to all spectral components minus the fundamental and the DC offset.

### Effective Number of Bits (ENOB)

ENOB specifies the dynamic performance of an ADC at a specific input frequency and sampling rate. An ideal ADC's error consists of quantization noise only. ENOB for a full-scale sinusoidal input waveform is computed from:

$$\text{ENOB} = \left( \frac{\text{SINAD} - 1.76}{6.02} \right)$$

# Dual 10-Bit, 120Mps, 3.3V, Low-Power ADC with Internal Reference and Parallel Outputs

## Total Harmonic Distortion (THD)

THD is typically the ratio of the RMS sum of the first four harmonics of the input signal to the fundamental itself. This is expressed as:

$$THD = 20 \times \log \left( \frac{\sqrt{V_2^2 + V_3^2 + V_4^2 + V_5^2}}{V_1} \right)$$

where  $V_1$  is the fundamental amplitude, and  $V_2$  through  $V_5$  are the amplitudes of the 2nd- through 5th-order harmonics.

## Spurious-Free Dynamic Range (SFDR)

SFDR is the ratio expressed in decibels of the RMS amplitude of the fundamental (maximum signal component) to the RMS value of the next largest spurious component, excluding DC offset.

## Intermodulation Distortion (IMD)

The two-tone IMD is the ratio expressed in decibels of either input tone to the worst 3rd-order (or higher) intermodulation products. The individual input tone levels are at -6.5dB full scale and their envelope is at -0.5dB full scale.

## Functional Diagram

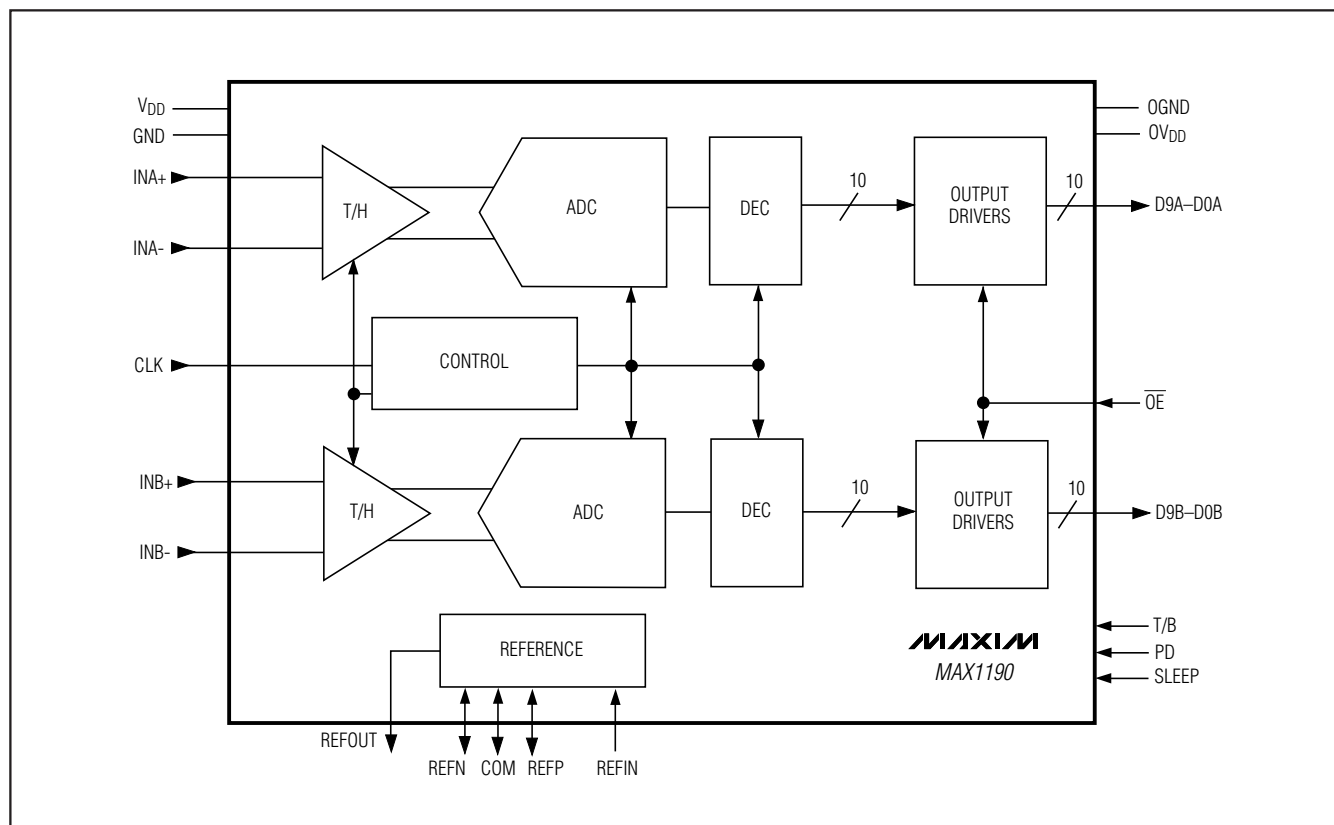

## Revision History

Pages changed at Rev 1: 1-15, 17, 19, 20, 21.

# Dual 10-Bit, 120MSPs, 3.3V, Low-Power ADC with Internal Reference and Parallel Outputs

## Package Information

(The package drawing(s) in this data sheet may not reflect the most current specifications. For the latest package outline information, go to [www.maxim-ic.com/packages](http://www.maxim-ic.com/packages).)

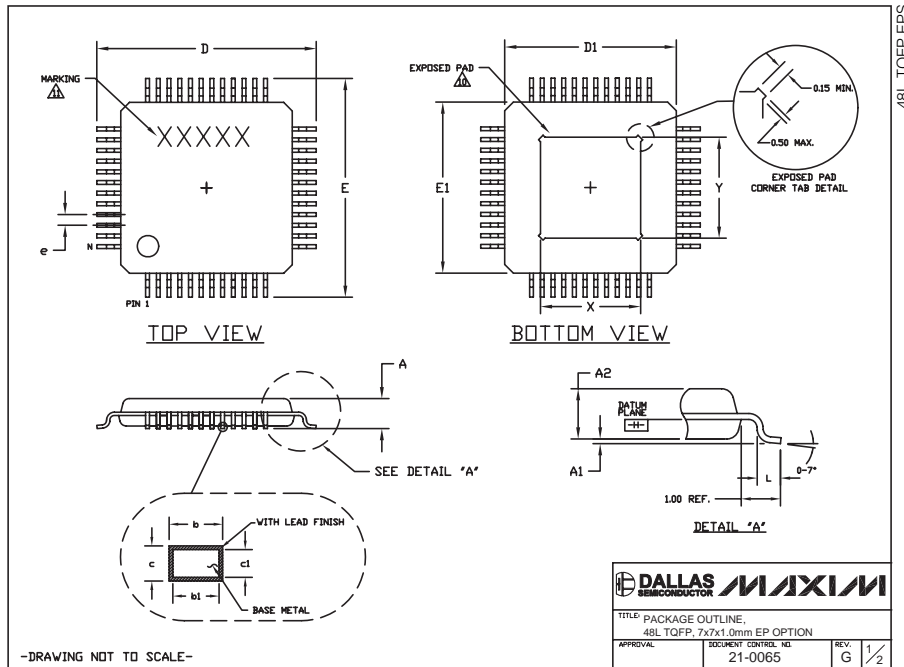

48L TQFP.EPS

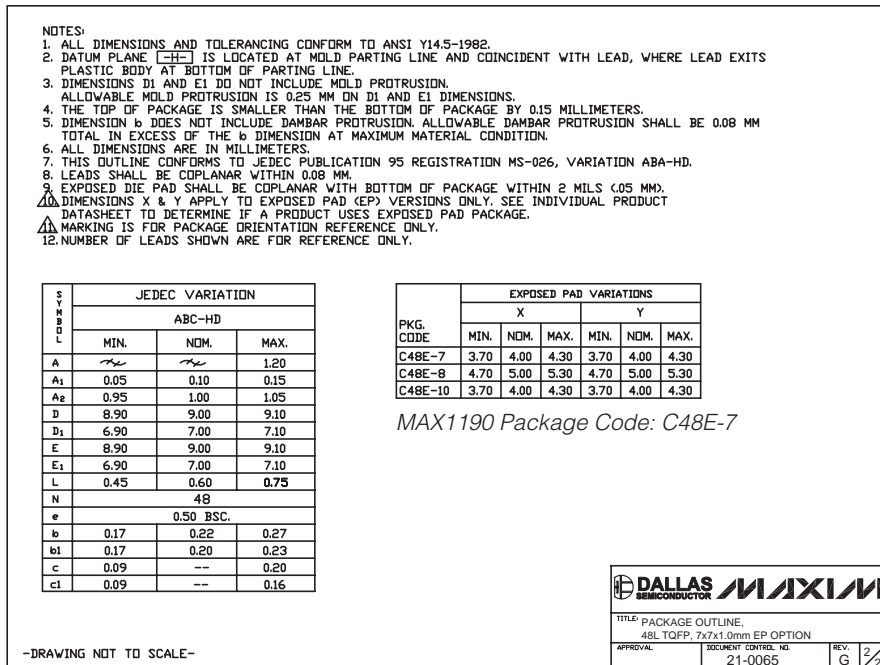

Maxim cannot assume responsibility for use of any circuitry other than circuitry entirely embodied in a Maxim product. No circuit patent licenses are implied. Maxim reserves the right to change the circuitry and specifications without notice at any time.

22 **Maxim Integrated Products, 120 San Gabriel Drive, Sunnyvale, CA 94086 408-737-7600**

## Looking for pricing, stock, or lifecycle information?

Click below to explore more details on WIN SOURCE:

-  [View MAX1190ECM+TD on WIN SOURCE](#)
-  [Maxim Integrated Information](#)

## Optimize Your Supply Chain with WIN SOURCE Solutions

-  Global Sourcing Solution
-  Obsolete Management
-  Cost Control Management
-  Shortage Management
-  Alternative Solution
-  Excess Inventory Management