



**THE DATASHEET OF
MAX1394MTB+T**





1.5V to 3.6V, 416ksps, 1-Channel True-Differential/ 2-Channel Single-Ended, 8-Bit, SAR ADCs

General Description

The MAX1391/MAX1394 micropower, serial-output, 8-bit, analog-to-digital converters (ADCs) operate with a single power supply from +1.5V to +3.6V. These ADCs feature automatic shutdown, fast wake-up, and a high-speed 3-wire interface. Power consumption is only 0.743mW ($V_{DD} = +1.5V$) at the maximum conversion rate of 416ksps. AutoShutdown™ between conversions reduces power consumption at slower throughput rates.

The MAX1391/MAX1394 require an external reference V_{REF} that has a wide range from 0.6V to V_{DD} . The MAX1391 provides one true-differential analog input that accepts signals ranging from 0 to V_{REF} (unipolar mode) or $\pm V_{REF}/2$ (bipolar mode). The MAX1394 provides two single-ended inputs that accept signals ranging from 0 to V_{REF} . Analog conversion results are available through a 5MHz 3-wire SPI™-/QSPI™-/MICROWIRE™-/digital signal processor (DSP)-compatible serial interface. Excellent dynamic performance, low voltage, low power, ease of use, and small package sizes make these converters ideal for portable battery-powered data-acquisition applications, as well as other applications that demand low-power consumption and minimal space.

The MAX1391/MAX1394 are available in a space-saving (3mm x 3mm), 10-pin TDFN package. The parts operate over the extended (-40°C to +85°C) temperature range.

Applications

Portable Datalogging
Data Acquisition
Medical Instruments
Battery-Powered Instruments
Process Control

Features

- ◆ 416ksps, 8-Bit Successive-Approximation Register (SAR) ADCs
- ◆ Single True-Differential Analog Input Channel with Unipolar-/Bipolar-Selected Input (MAX1391)
- ◆ Dual Single-Ended Input Channel with Channel-Selected Input (MAX1394)
- ◆ ± 0.2 LSB INL, ± 0.2 LSB DNL, No Missing Codes
- ◆ ± 0.25 LSB Total Unadjusted Error (TUE)
- ◆ 49dB SINAD at 100kHz Input Frequency
- ◆ Single-Supply Voltage (+1.5V to +3.6V)
- ◆ 0.97mW at 416ksps, 1.8V
- ◆ 0.230mW at 100ksps, 1.8V
- ◆ 3.1 μ W at 1ksps, 1.8V
- ◆ < 1 μ A Shutdown Current
- ◆ External Reference (0.6V to V_{DD})
- ◆ AutoShutdown Between Conversions
- ◆ SPI-/QSPI-/MICROWIRE-/DSP-Compatible, 3- or 4-Wire Serial Interface
- ◆ Small (3mm x 3mm), 10-Pin TDFN

Typical Operating Circuit and Pin Configurations appear at end of data sheet.

AutoShutdown is a trademark of Maxim Integrated Products, Inc.
SPI/QSPI are trademarks of Motorola, Inc.
MICROWIRE is a trademark of National Semiconductor Corp.

Ordering Information

PART	TEMP RANGE	PIN-PACKAGE	ANALOG INPUTS	TOP MARK
MAX1391ETB+	-40°C to +85°C	10 TDFN-EP*	1-CH DIFF	AOX
MAX1394ETB+	-40°C to +85°C	10 TDFN-EP*	2-CH S/E	APA

+Denotes a lead(Pb)-free/RoHS-compliant package.

*EP = Exposed pad.



1.5V to 3.6V, 416ksps, 1-Channel True-Differential/ 2-Channel Single-Ended, 8-Bit, SAR ADCs

ABSOLUTE MAXIMUM RATINGS

V_{DD} to GND-0.3V to +4V
 SCLK, CS, OE, CH1/CH2, UNI/BIP,
 DOUT to GND-0.3V to (V_{DD} + 0.3V)
 AIN+, AIN-, AIN1, AIN2, REF to GND-0.3V to (V_{DD} + 0.3V)
 Maximum Current into Any Pin±50mA
 Continuous Power Dissipation (T_A = +70°C)
 10-Pin TDFN (derate 18.5mW/°C above +70°C)1481.5mW

Operating Temperature Ranges
 MAX139_E_-40°C to +85°C
 Junction Temperature+150°C
 Storage Temperature Range-60°C to +150°C
 Lead Temperature (soldering, 10s)+300°C

Stresses beyond those listed under "Absolute Maximum Ratings" may cause permanent damage to the device. These are stress ratings only, and functional operation of the device at these or any other conditions beyond those indicated in the operational sections of the specifications is not implied. Exposure to absolute maximum rating conditions for extended periods may affect device reliability.

ELECTRICAL CHARACTERISTICS

(V_{DD} = +1.5V to +3.6V, V_{REF} = V_{DD}, C_{REF} = 0.1μF, f_{SCLK} = 5MHz, T_A = T_{MIN} to T_{MAX}, unless otherwise noted. Typical values are at T_A = +25°C.) (Note 1)

PARAMETER	SYMBOL	CONDITIONS	MIN	TYP	MAX	UNITS
DC ACCURACY (Note 2)						
Resolution			8			Bits
Integral Nonlinearity	INL				±0.2	LSB
Differential Nonlinearity	DNL	No missing code overtemperature			±0.2	LSB
Offset Error					±0.15	LSB
Gain Error		Offset nulled			±0.15	LSB
Total Unadjusted Error	TUE				±0.25	LSB
Offset-Error Temperature Coefficient				±25		mLSB/°C
Gain-Error Temperature Coefficient				±0.06		mLSB/°C
Channel-to-Channel Offset Matching		MAX1394 only		±0.05		LSB
Channel-to-Channel Gain Matching		MAX1394 only		±0.05		LSB
Input Common-Mode Rejection	CMR	V _{CM} = 0 to V _{DD} , MAX1391 only		±0.1		mV/V
DYNAMIC SPECIFICATIONS (Note 3)						
Signal-to-Noise Plus Distortion	SINAD		49			dB
Signal-to-Noise Ratio	SNR		49			dB
Total Harmonic Distortion	THD				-65	dBc
Spurious-Free Dynamic Range	SFDR				-66	dBc
Intermodulation Distortion	IMD	f _{IN1} = 98kHz at -6.5dBFS, f _{IN2} = 102kHz at -6.5dBFS		-73		dB
Channel-to-Channel Crosstalk		MAX1394 only		-70		dB
Full-Power Bandwidth		-3dB point		4		MHz
Full-Linear Bandwidth		SINAD > 48dB	MAX1391	200		kHz
			MAX1394	150		
CONVERSION RATE						
Conversion Time	t _{CONV}	9 clock cycles per conversion	1.8			μs

1.5V to 3.6V, 416ksps, 1-Channel True-Differential/ 2-Channel Single-Ended, 8-Bit, SAR ADCs

MAX1391/MAX1394

ELECTRICAL CHARACTERISTICS (continued)

($V_{DD} = +1.5V$ to $+3.6V$, $V_{REF} = V_{DD}$, $C_{REF} = 0.1\mu F$, $f_{SCLK} = 5MHz$, $T_A = T_{MIN}$ to T_{MAX} , unless otherwise noted. Typical values are at $T_A = +25^\circ C$.) (Note 1)

PARAMETER	SYMBOL	CONDITIONS	MIN	TYP	MAX	UNITS
Throughput Rate		12 clocks per conversion, includes power-up acquisition and conversion time			416	ksps
Power-Up and Acquisition Time	t_{ACQ}	Three SCLK cycles	600			ns
Aperture Delay	t_{AD}			8		ns
Aperture Jitter	t_{AJ}			30		ps
Serial-Clock Frequency	f_{CLK}		0.1		5.0	MHz
ANALOG INPUTS (AIN+, AIN-, AIN1, AIN2)						
Input Voltage Range	V_{IN}	Unipolar	0		V_{REF}	V
		Bipolar, MAX1391 only, (AIN+ - AIN-)	$-V_{REF}/2$		$+V_{REF}/2$	
Common-Mode Input Voltage Range	V_{CM}	Bipolar, MAX1391 only, [(AIN+) + (AIN-)] / 2	0		V_{DD}	V
Input Leakage Current		Channel not selected, or conversion stopped, or in shutdown mode			± 1.5	μA
Input Capacitance				16		pF
REFERENCE INPUT (REF)						
REF Input Voltage Range	V_{REF}		0.6		$V_{DD} + 0.05$	V
REF Input Capacitance				24		pF
REF DC Leakage Current				0.025	± 2.5	μA
REF Input Dynamic Current		416ksps		20	60	μA
DIGITAL INPUTS (SCLK, CS, OE, CH1/CH2, UNI/BIP)						
Input-Voltage Low	V_{IL}				$0.3 \times V_{DD}$	V
Input-Voltage High	V_{IH}		$0.7 \times V_{DD}$			V
Input Hysteresis				$0.06 \times V_{DD}$		V
Input Leakage Current	I_{IL}	Inputs at GND or V_{DD}			± 1	μA
Input Capacitance	C_{IN}	\overline{CS} , \overline{OE}		1		pF
		$\overline{CH1/CH2}$, $\overline{UNI/BIP}$		12.5		
DIGITAL OUTPUT (DOUT)						
Output-Voltage Low	V_{OL}	$I_{SINK} = 2mA$			$0.1 \times V_{DD}$	V
Output-Voltage High	V_{OH}	$I_{SOURCE} = 2mA$	$0.9 \times V_{DD}$			V
Tri-State Leakage Current	I_{LT}	$\overline{OE} = V_{DD}$			± 1	μA
Tri-State Output Capacitance	C_{OUT}	$\overline{OE} = V_{DD}$		10		pF
POWER SUPPLY						
Positive Supply Voltage	V_{DD}		1.5		3.6	V

1.5V to 3.6V, 416ksps, 1-Channel True-Differential/ 2-Channel Single-Ended, 8-Bit, SAR ADCs

ELECTRICAL CHARACTERISTICS (continued)

($V_{DD} = +1.5V$ to $+3.6V$, $V_{REF} = V_{DD}$, $C_{REF} = 0.1\mu F$, $f_{SCLK} = 5MHz$, $T_A = T_{MIN}$ to T_{MAX} , unless otherwise noted. Typical values are at $T_A = +25^\circ C$.) (Note 1)

PARAMETER	SYMBOL	CONDITIONS	MIN	TYP	MAX	UNITS
Positive Supply Current (Note 4)	I_{DD}	$f_{SAMPLE} = 100ksps$	$V_{DD} = 1.6V$	125	150	μA
			$V_{DD} = 3V$	150	200	
		$f_{SAMPLE} = 416ksps$	$V_{DD} = 1.6V$	520	600	
			$V_{DD} = 3V$	710	800	
		Power-down mode (Note 5)		5	10	
Power-down mode (Note 6)		0.2	± 2.5			
Power-Supply Rejection	PSR	$V_{DD} = 1.6V$ to $3.6V$, full-scale input (Note 7)	± 150		± 1000	$\mu V/V$

TIMING CHARACTERISTICS

($V_{DD} = +1.5V$ to $+3.6V$, $V_{REF} = V_{DD}$, $C_{REF} = 0.1\mu F$, $f_{SCLK} = 5MHz$, $T_A = T_{MIN}$ to T_{MAX} , unless otherwise noted. Typical values are at $T_A = +25^\circ C$.) (Figure 1)

PARAMETER	SYMBOL	CONDITIONS	MIN	TYP	MAX	UNITS
SCLK Clock Period	t_{CP}		200		10,000	ns
SCLK Pulse-Width High	t_{CH}		90			ns
SCLK Pulse-Width Low	t_{CL}		90			ns
\overline{CS} Fall to SCLK Rise Setup	t_{CSS}		80			ns
SCLK Rise to \overline{CS} Fall Ignore	t_{CSO}		0			ns
SCLK Fall to DOUT Valid	t_{DOV}	$C_{LOAD} = 0$ to $30pF$	10		80	ns
\overline{OE} Rise to DOUT Disable	t_{DOD}			6	20	ns
\overline{OE} Fall to DOUT Enable	t_{DOE}			9	20	ns
\overline{CS} Pulse-Width High and Low	t_{CSW}		80			ns
\overline{OE} Pulse-Width High and Low	t_{OEW}		80			ns
$\overline{CH1}/\overline{CH2}$ Setup Time (to the First SCLK)	t_{CHS}	MAX1394 only	10			ns
$\overline{CH1}/\overline{CH2}$ Hold Time (to the First SCLK)	t_{CHH}	MAX1394 only	0			ns
$\overline{UNI}/\overline{BIP}$ Setup Time (to the First SCLK)	t_{UBS}	MAX1391 only	10			ns
$\overline{UNI}/\overline{BIP}$ Hold Time (to the First SCLK)	t_{UBH}	MAX1391 only	0			ns

Note 1: Devices are production tested at room and $+85^\circ C$. Specification to $-40^\circ C$ are guaranteed by design.

Note 2: $V_{DD} = 1.6V$, $V_{REF} = 1.6V$, and $V_{AIN} = 1.6V$.

Note 3: $V_{DD} = 1.6V$, $V_{REF} = 1.6V$, $V_{AIN} = 1.6V_{P-P}$, $f_{SCLK} = 5MHz$, $f_{SAMPLE} = 416ksps$, and f_{IN} (sine wave) = $100kHz$.

Note 4: All digital inputs swing between V_{DD} and GND. $V_{REF} = V_{DD}$, $f_{IN} = 100kHz$ sine wave, $V_{AIN} = V_{REF_{P-P}}$, $C_{LOAD} = 30pF$ on DOUT.

Note 5: $\overline{CS} = V_{DD}$, $\overline{OE} = \overline{UNI}/\overline{BIP} = \overline{CH1}/\overline{CH2} = V_{DD}$ or GND, SCLK is active.

Note 6: $\overline{CS} = V_{DD}$, $\overline{OE} = \overline{UNI}/\overline{BIP} = \overline{CH1}/\overline{CH2} = V_{DD}$ or GND, SCLK is inactive.

Note 7: Change in V_{AIN} at code boundary 254.5.

1.5V to 3.6V, 416ksps, 1-Channel True-Differential/ 2-Channel Single-Ended, 8-Bit, SAR ADCs

MAX1391/MAX1394

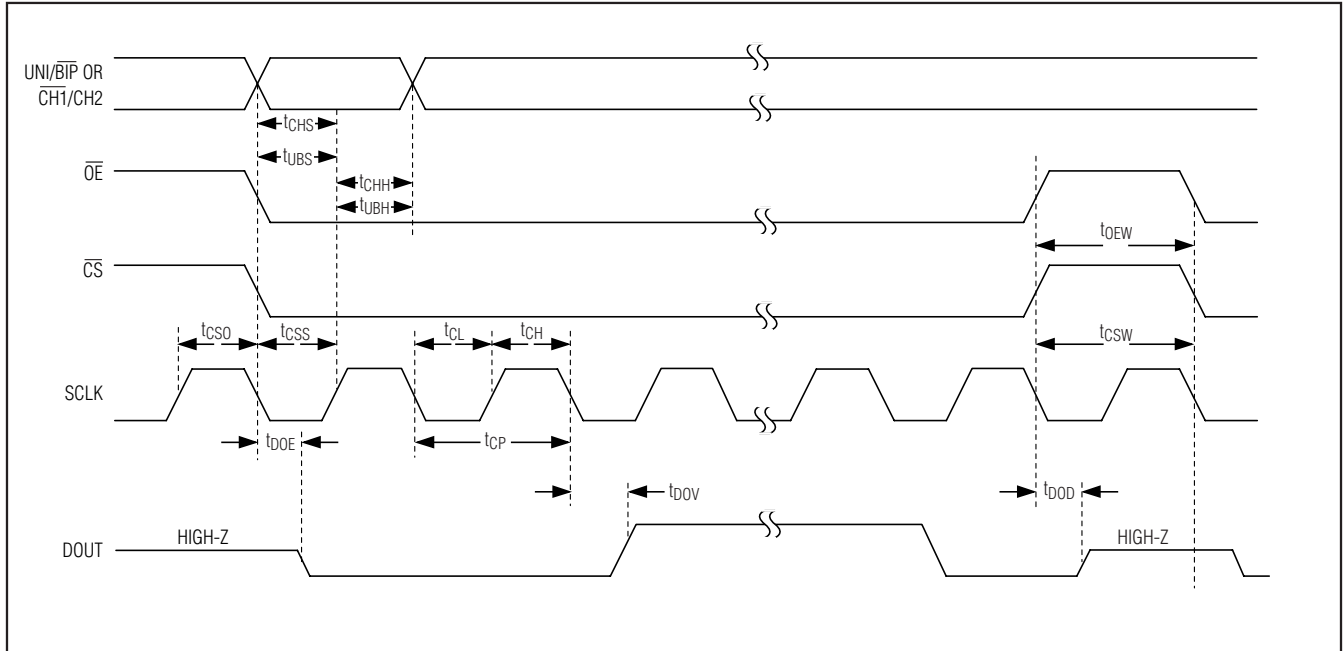

Figure 1. Detailed Serial-Interface Timing Diagram

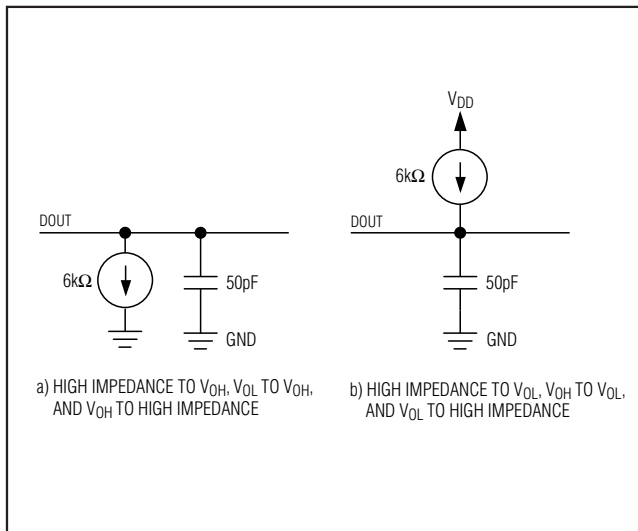
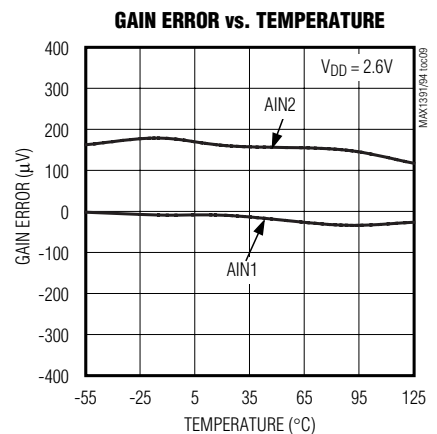
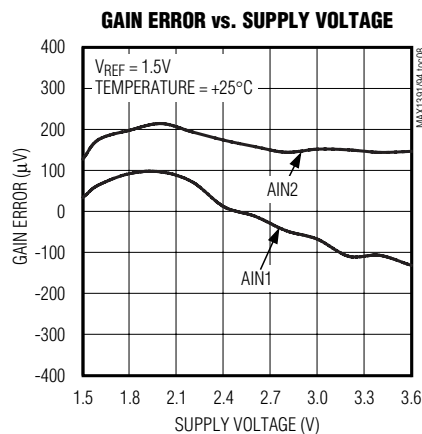
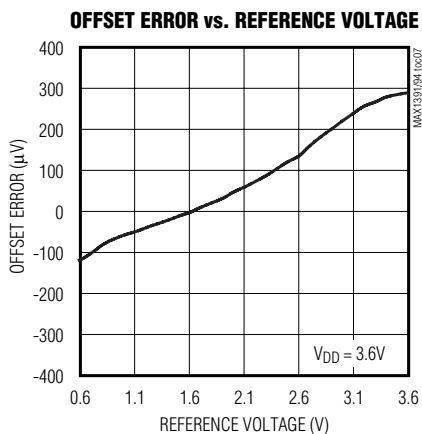
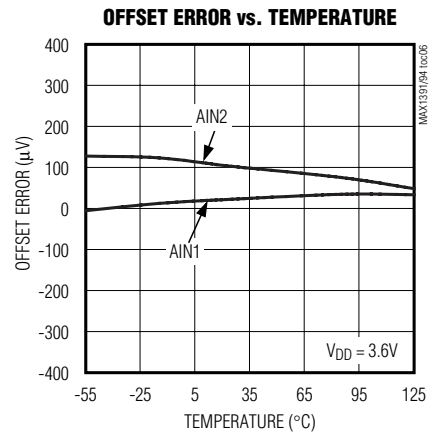
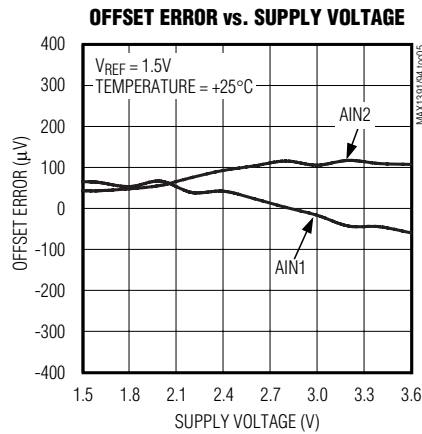
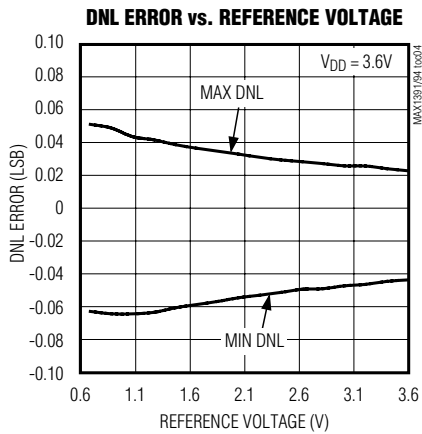
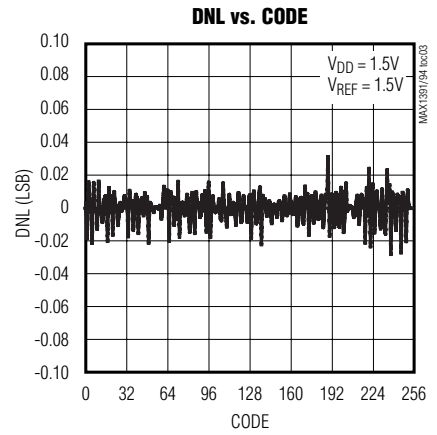
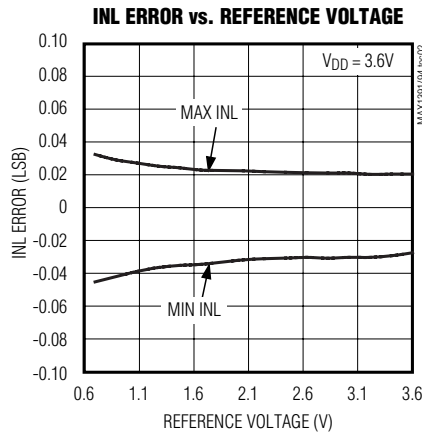
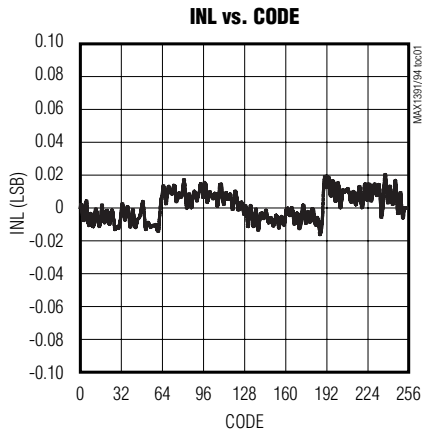

Figure 2. Load Circuits for Enable/Disable Times

1.5V to 3.6V, 416ksp/s, 1-Channel True-Differential/ 2-Channel Single-Ended, 8-Bit, SAR ADCs

Typical Operating Characteristics

($V_{DD} = +1.6V$, $V_{REF} = +1.6V$, $C_{REF} = 0.1\mu F$, $C_L = 30pF$, $f_{SCLK} = 5MHz$, $T_A = +25^\circ C$, unless otherwise noted.)



1.5V to 3.6V, 416kps, 1-Channel True-Differential/ 2-Channel Single-Ended, 8-Bit, SAR ADCs

MAX1391/MAX1394

Typical Operating Characteristics (continued)

($V_{DD} = +1.6V$, $V_{REF} = +1.6V$, $C_{REF} = 0.1\mu F$, $C_L = 30pF$, $f_{SCLK} = 5MHz$, $T_A = +25^\circ C$, unless otherwise noted.)

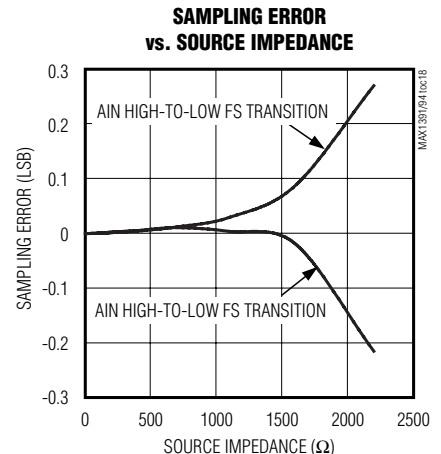
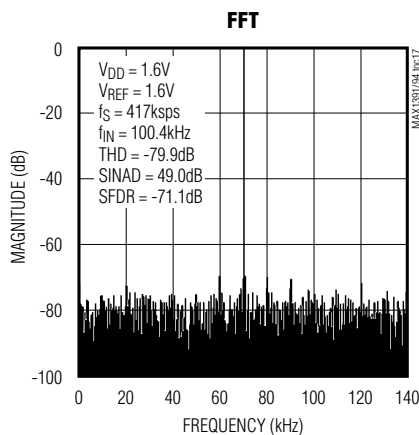
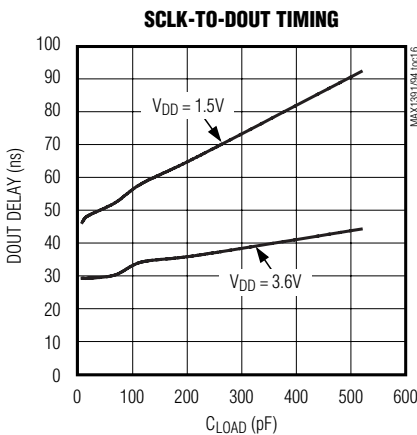
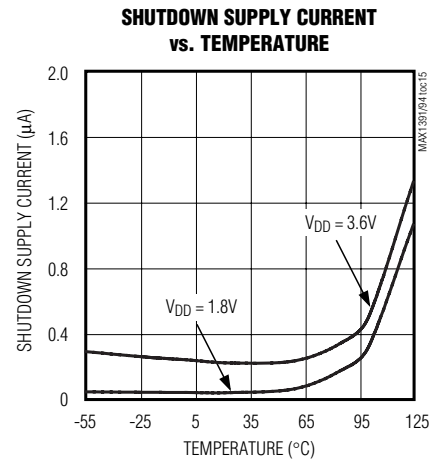
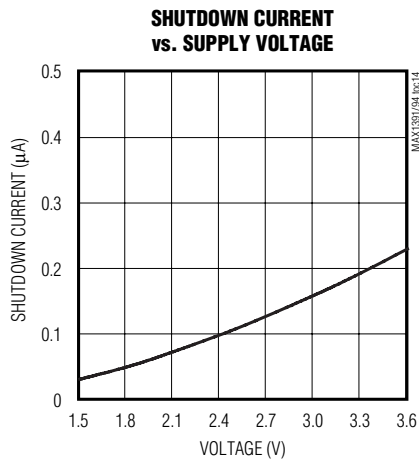
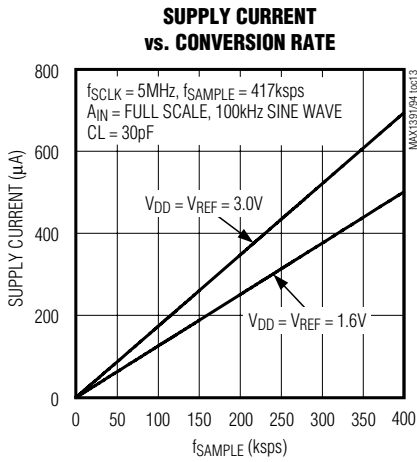
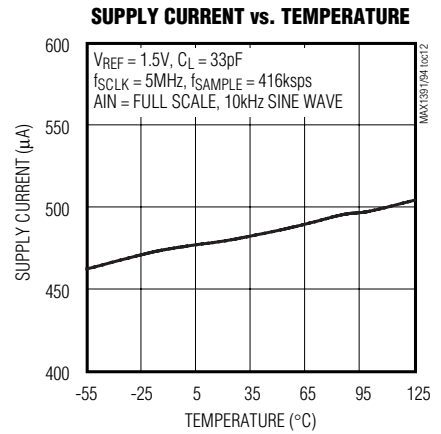
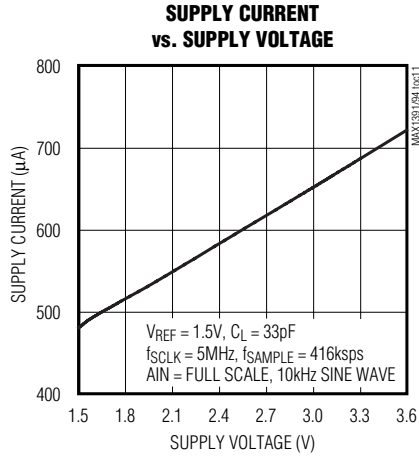
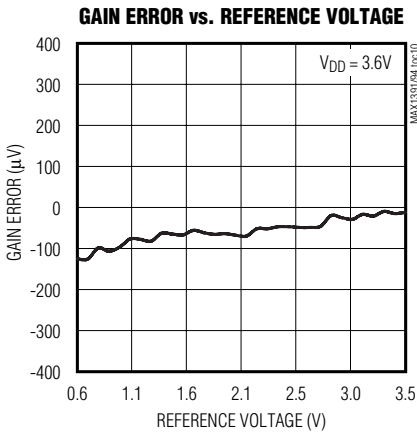

1.5V to 3.6V, 416ksps, 1-Channel True-Differential/ 2-Channel Single-Ended, 8-Bit, SAR ADCs

Pin Description

PIN		NAME	FUNCTION
MAX1391	MAX1394		
1	1	V _{DD}	Positive Supply Voltage. Connect V _{DD} to a 1.6V to 3.6V power supply. Bypass V _{DD} to GND with a 0.1µF capacitor as close as possible to the device.
2	—	AIN-	Negative Analog Input
—	2	AIN2	Analog Input Channel 2
3	—	AIN+	Positive Analog Input
—	3	AIN1	Analog Input Channel 1
4	4	GND	Ground
5	5	REF	External Reference Voltage Input. V _{REF} = 0.6V to (V _{DD} + 0.05V). Bypass REF to GND with a 0.1µF capacitor as close as possible to the device.
6	—	UNI/BIP	Input-Mode Select. Drive UNI/BIP high to select unipolar input mode. Pull UNI/BIP low to select bipolar input mode. In unipolar mode, the output data is in straight binary format. In bipolar mode, the output data is in two's complement format.
—	6	CH1/CH2	Channel-Select Input. Pull CH1/CH2 low to select channel 1. Drive CH1/CH2 high to select channel 2.
7	7	OE	Active-Low Output Enable. Pull OE low to enable DOUT. Drive OE high to disable DOUT. Connect to CS to interface with SPI, QSPI, and MICROWIRE devices or set low to interface with DSP devices.
8	8	CS	Active-Low Chip-Select Input. A falling edge on CS initiates power-up and acquisition.
9	9	DOUT	Serial-Data Output. DOUT changes state on the falling edge of SCLK. DOUT is high impedance when OE is high.
10	10	SCLK	Serial-Clock Input. SCLK drives the conversion process and clocks data out. Acquisition ends on the 3rd falling edge after the CS falling edge. The LSB is clocked out on the SCLK 11th falling edge and the device enters AutoShutdown mode (see Figures 8, 9, and 10).
—	—	EP	Exposed Pad. Not internally connected. Connect the exposed pad to GND or leave floating.

Detailed Description

The MAX1391/MAX1394 use an input track and hold (T/H) circuit along with a SAR to convert an analog input signal to a serial 8-bit digital output data stream. The serial interface provides easy interfacing to microprocessors and DSPs. Figure 3 shows the simplified functional diagram for the MAX1391 (1 channel, true differential) and the MAX1394 (2 channels, single ended).

True-Differential Analog Input T/H

The equivalent input circuit of Figure 4 shows the MAX1391/MAX1394 input architecture that is composed of a T/H, a comparator, and a switched-capacitor DAC. The T/H enters its tracking mode on the falling edge of CS (while OE is held low). The positive input capacitor is connected to AIN+ (MAX1391), or to AIN1 or AIN2 (MAX1394). The negative input capacitor is connected to AIN- (MAX1391) or GND (MAX1394). The T/H enters its hold mode on the 3rd falling edge of SCLK and the dif-

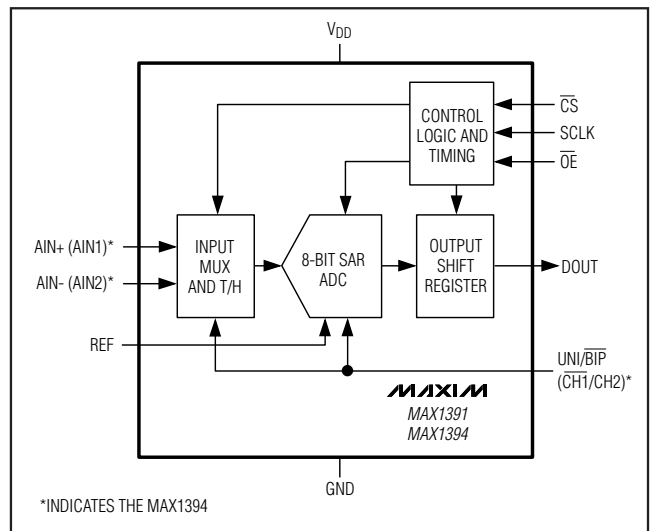

Figure 3. Simplified Functional Diagram

1.5V to 3.6V, 416ksps, 1-Channel True-Differential/ 2-Channel Single-Ended, 8-Bit, SAR ADCs

ference between the sampled positive and negative input voltages is converted. The time required for the T/H to acquire an input signal is determined by how quickly its input capacitance is charged. The required acquisition time lengthens as the input signal's source impedance increases. The acquisition time, t_{ACQ} , is the minimum time needed for the signal to be acquired. It is calculated by the following equation:

$$t_{ACQ} \geq 5.6 \times (R_{SOURCE} + R_{IN}) \times C_{IN} + t_{PU}$$

where

R_{SOURCE} is the source impedance of the input signal.

$R_{IN} = 500\Omega$, which is the equivalent differential analog input resistance.

$C_{IN} = 16\text{pF}$, which is the equivalent differential analog input capacitance.

$t_{PU} = 400\text{ns}$.

Note: t_{ACQ} is never less than 600ns and any source impedance below 400 Ω does not significantly affect the ADC's AC performance.

Analog Input Bandwidth

The ADC's input-tracking circuitry has a 4MHz full-power bandwidth, making it possible to digitize high-speed transient events and measure periodic signals with bandwidths exceeding the ADC's sampling rate by using undersampling techniques.

Use anti-alias filtering to avoid high-frequency signals being aliased into the frequency band of interest.

Analog Input Range and Protection

The MAX1391/MAX1394 produce a digital output that corresponds to the analog input voltage as long as the analog inputs are within their specified range. When operating the MAX1391 in unipolar mode ($UNI/BIP = 1$), the specified differential analog input range is from 0 to V_{REF} . When operating in bipolar mode ($UNI/BIP = 0$), the differential analog input range is from $-V_{REF}/2$ to $+V_{REF}/2$ with a common-mode range of 0 to V_{DD} . The MAX1394 has an input range from 0 to V_{REF} .

Internal protection diodes confine the analog input voltage within the region of the analog power input rails (V_{DD} , GND) and allow the analog input voltage to swing from $GND - 0.3\text{V}$ to $V_{DD} + 0.3\text{V}$ without damage. Input voltages beyond $GND - 0.3\text{V}$ and $V_{DD} + 0.3\text{V}$ forward bias the internal protection diodes. In this situation, limit the forward diode current to less than 50mA to avoid damage to the MAX1391/MAX1394.

Output Data Format

Figures 8, 9, and 10 illustrate the conversion timing for the MAX1391/MAX1394. Twelve SCLK cycles are required to read the conversion result and data on DOUT transitions on the falling edge of SCLK. The conversion result contains 4 zeros, followed by 8 data bits with the data in MSB-first format. For the MAX1391, data is straight binary for unipolar mode and two's complement for bipolar mode. For the MAX1394, data is always straight binary.

Transfer Function

Figure 5 shows the unipolar transfer function for the MAX1391/MAX1394. Figure 6 shows the bipolar transfer function for the MAX1391. Code transitions occur halfway between successive-integer LSB values.

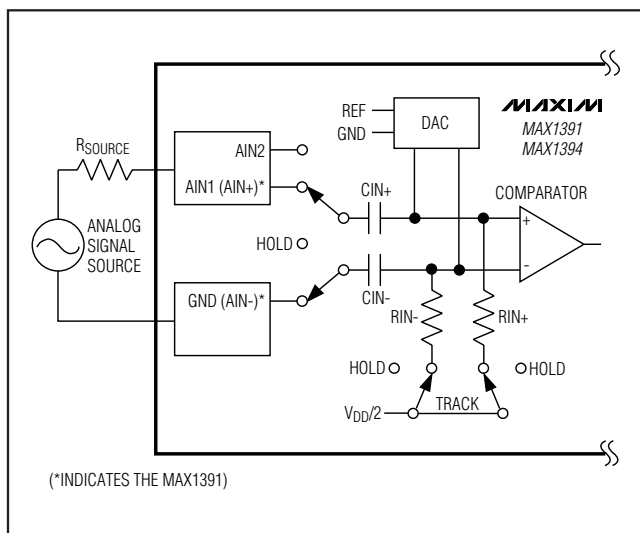

Figure 4. Equivalent Input Circuit

1.5V to 3.6V, 416ksp/s, 1-Channel True-Differential/ 2-Channel Single-Ended, 8-Bit, SAR ADCs

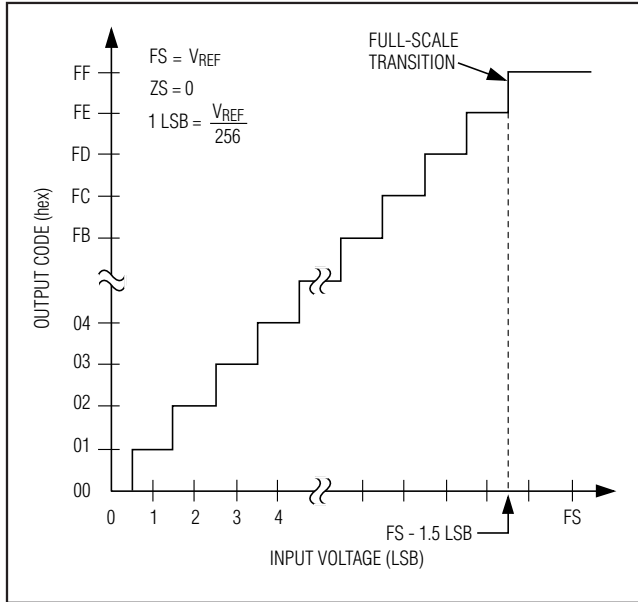

Figure 5. Unipolar Transfer Function

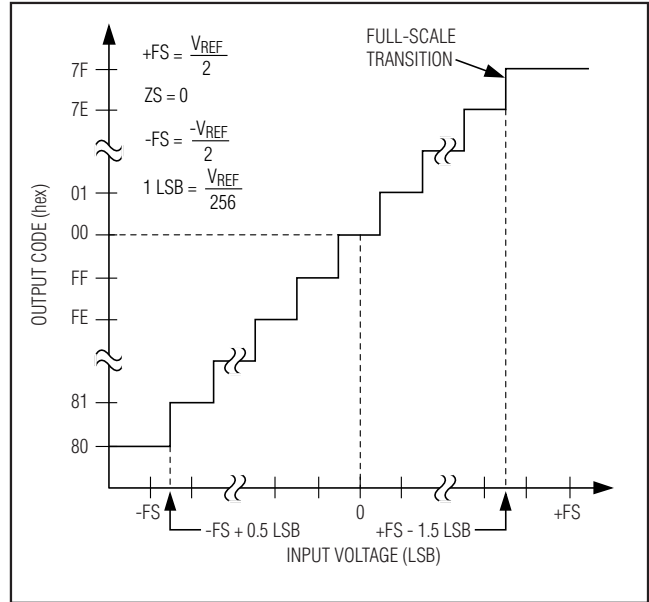

Figure 6. Bipolar Transfer Function

Applications Information

Starting a Conversion

A falling edge on \overline{CS} initiates the power-up sequence and begins acquiring the analog input as long as \overline{OE} is also asserted low. On the 3rd SCLK falling edge, the analog input is held for conversion. The most significant bit (MSB) decision is made and clocked onto DOUT on the 4th SCLK falling edge. Valid DOUT data is available to be clocked into the master (microcontroller (μC)) on the following SCLK rising edge. The rest of the bits are decided and clocked out to DOUT on each successive SCLK falling edge. See Figures 8 and 9 for conversion timing diagrams.

Once a conversion has been initiated, \overline{CS} can go high at any time. Further falling edges of \overline{CS} do not reinstate an acquisition cycle until the current conversion completes. Once a conversion completes, the first falling edge of \overline{CS} begins another acquisition/conversion cycle.

Selecting Unipolar or Bipolar Mode (MAX1391 Only)

Drive $\overline{UNI/BIP}$ high to select unipolar mode or pull $\overline{UNI/BIP}$ low to select bipolar mode. $\overline{UNI/BIP}$ can be connected to V_{DD} for logic-high, to GND for logic-low, or actively driven. $\overline{UNI/BIP}$ needs to be stable for t_{UBS} prior to the first rising edge of SCLK after the \overline{CS} falling edge (see Figure 1) for a valid conversion result when being actively driven.

Selecting Analog Input AIN1 or AIN2 (MAX1394 Only)

Pull $\overline{CH1/CH2}$ low to select AIN1 or drive $\overline{CH1/CH2}$ high to select AIN2 for conversion. $\overline{CH1/CH2}$ can be connected to V_{DD} for logic-high, to GND for logic-low, or actively driven. $\overline{CH1/CH2}$ needs to be stable for t_{CHS} prior to the first rising edge of SCLK after the \overline{CS} falling edge (see Figure 1) for a valid conversion result when being actively driven.

1.5V to 3.6V, 416ksps, 1-Channel True-Differential/ 2-Channel Single-Ended, 8-Bit, SAR ADCs

AutoShutdown Mode

The ADC automatically powers down on the SCLK falling edge that clocks out the LSB. This is the falling edge after the 11th SCLK. DOUT goes low when the LSB has been clocked into the master (μC) on the 16th rising SCLK edge.

Alternatively, drive $\overline{\text{OE}}$ high to force the MAX1391/MAX1394 into power-down. Whenever $\overline{\text{OE}}$ goes high, the ADC powers down and disables DOUT regardless of $\overline{\text{CS}}$, SCLK, or the state of the ADC. DOUT enters a high-impedance state after t_{DOD} .

External Reference

The MAX1391/MAX1394 use an external reference between 0.6V and ($V_{\text{DD}} + 50\text{mV}$). Bypass REF with a

0.1 μF capacitor to GND for best performance (see the *Typical Operating Circuit*).

Serial Interface

The MAX1391/MAX1394 serial interface is fully compatible with SPI, QSPI, and MICROWIRE (see Figure 7). If a serial interface is available, set the μC 's serial interface in master mode so the μC generates the serial clock. Choose a clock frequency between 100kHz and 5MHz. $\overline{\text{CS}}$ and $\overline{\text{OE}}$ can be connected together and driven simultaneously. $\overline{\text{OE}}$ can also be connected to GND if the DOUT bus is not shared and driven independently.

SPI and MICROWIRE

When using SPI or MICROWIRE, make the μC the bus master and set $\text{CPOL} = 0$ and $\text{CPHA} = 0$ or $\text{CPOL} = 1$ and $\text{CPHA} = 1$. (These are the bits in the SPI or MICROWIRE control register.) Two consecutive 1-byte reads are required to get the entire 8-bit result from the ADC. The MAX1391/MAX1394 shut down after clocking out the LSB. DOUT then becomes high impedance. DOUT transitions on SCLK's falling edge and is clocked into the μC on the SCLK's rising edge. See Figure 7 for connections and Figures 8 and 9 for timing diagrams. The conversion result contains 4 zeros, followed by the 8 data bits with the data in MSB-first format. When using $\text{CPOL} = 0$ and $\text{CPHA} = 0$ or $\text{CPOL} = 1$ and $\text{CPHA} = 1$, the MSB of the data is clocked into the μC on the SCLK's fifth rising edge. To be compatible with SPI and MICROWIRE, connect $\overline{\text{CS}}$ and $\overline{\text{OE}}$ together and drive simultaneously.

QSPI

Unlike SPI, which requires two 1-byte reads to acquire the 8 bits of data from the ADC, QSPI allows the minimum number of clock cycles necessary to clock in the data. The MAX1391/MAX1394 require a minimum of 12 clock cycles from the μC to clock out the 8 bits of data. See Figure 7 for connections and Figures 8 and 9 for timing diagrams. The conversion result contains 4 zeros, followed by the 8 data bits with the data in MSB-first format. The MAX1391/MAX1394 shut down after clocking out the LSB. DOUT then becomes high impedance. When using $\text{CPOL} = 0$ and $\text{CPHA} = 0$ or $\text{CPOL} = 1$ and $\text{CPHA} = 1$, the MSB of the data is clocked into the μC on the SCLK's fifth rising edge. To be compatible with QSPI, connect $\overline{\text{CS}}$ and $\overline{\text{OE}}$ together and drive simultaneously.

DSP Interface

Figure 10 shows the timing for DSP operation. Figure 11 shows the connections between the MAX1391/MAX1394 and several common DSPs.

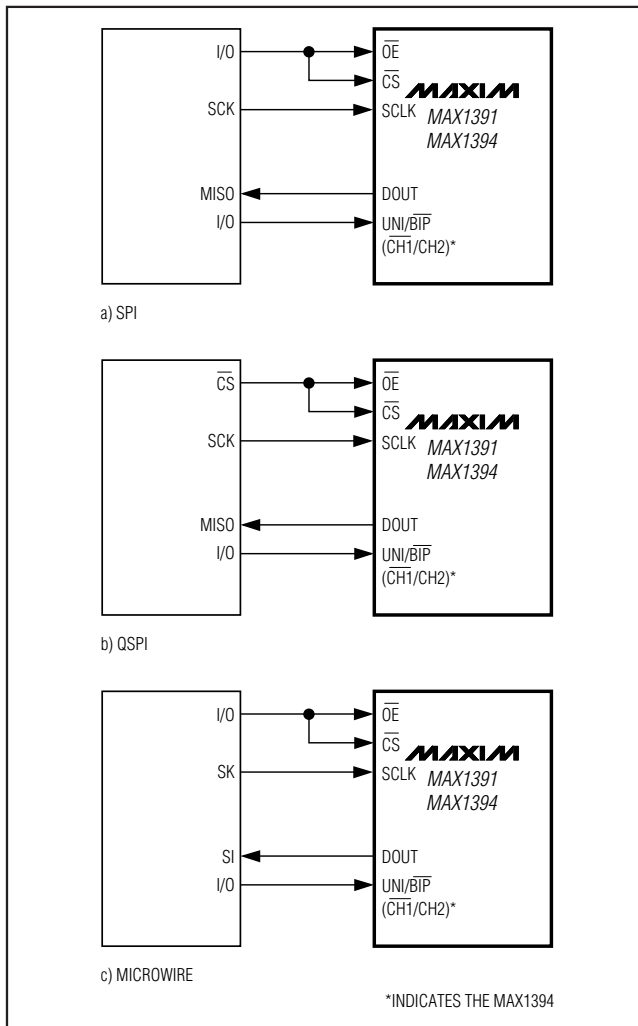

Figure 7. Common Serial-Interface Connections to the MAX1391/MAX1394

1.5V to 3.6V, 416ksp/s, 1-Channel True-Differential/ 2-Channel Single-Ended, 8-Bit, SAR ADCs

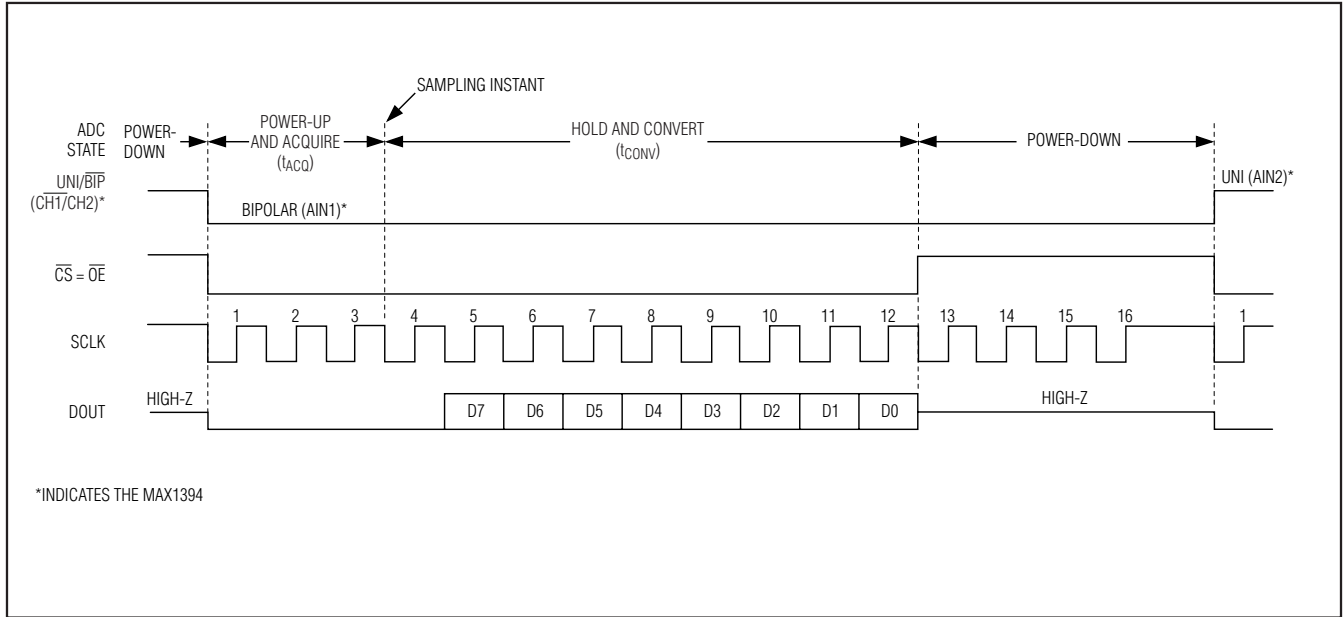

Figure 8. Serial-Interface Timing for SPI/QSPI ($CPOL = CPHA = 1$) and MICROWIRE ($G6 = 0, G5 = 1$)

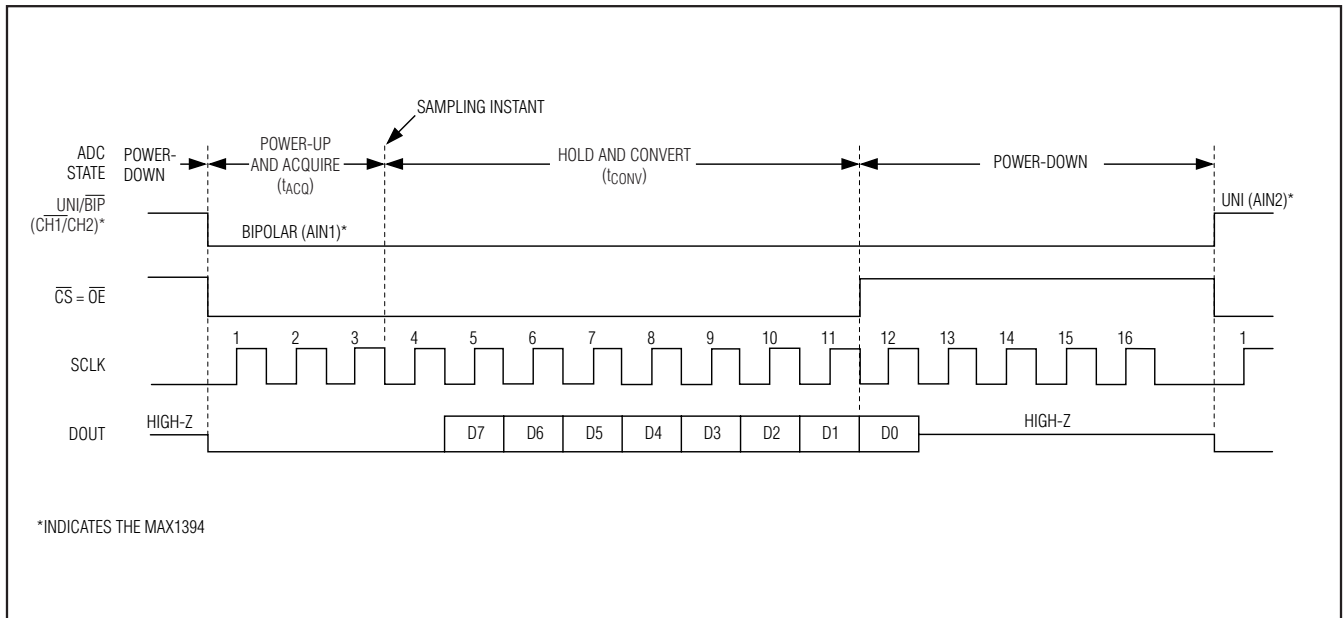

Figure 9. Serial-Interface Timing for SPI/QSPI ($CPOL = CPHA = 0$) and MICROWIRE ($G6 = 0, G5 = 0$)

1.5V to 3.6V, 416ksps, 1-Channel True-Differential/ 2-Channel Single-Ended, 8-Bit, SAR ADCs

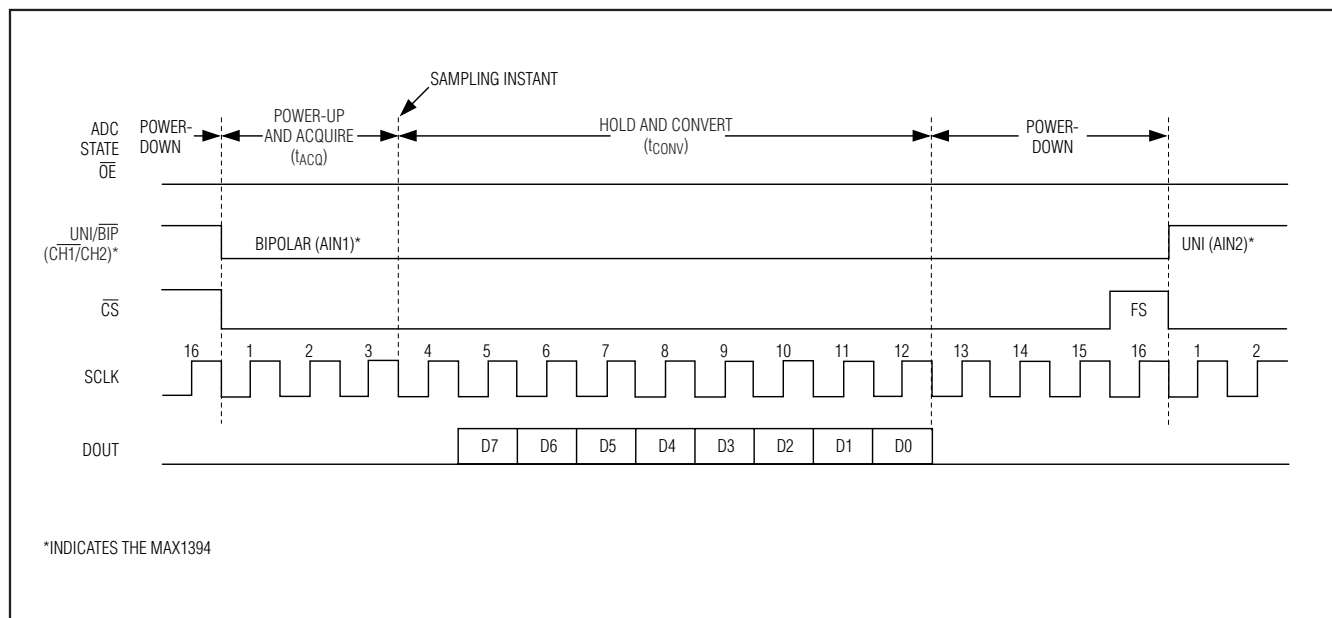

Figure 10. DSP Serial-Timing Diagram

As shown in Figure 11, drive the MAX1391/MAX1394 chip-select input (\overline{CS}) with the DSP's frame-sync signal. \overline{OE} may be connected to GND or driven independently. For continuous conversion operation, keep \overline{OE} low and make the \overline{CS} falling edge coincident with the 16th falling edge of the SCLK.

Unregulated Two-Cell or Single Lithium LiMnO₂ Cell Operation

Low operating voltage (1.5V to 3.6V) and ultra-low-power consumption make the MAX1391/MAX1394 ideal for low cost, unregulated, battery-powered applications without the need for a DC-DC converter. Power the MAX1391/MAX1394 directly from two alkaline/NiMH/NiCd cells in series or a single lithium coin cell as shown in the *Typical Operating Circuit*.

Fresh alkaline cells have a voltage of approximately 1.5V per cell (3V with 2 cells in series) and approach end of life at 0.8V (1.6V with 2 cells in series). A typical 2 x AA alkaline discharge curve is shown in Figure 12a. A typical CR2032 lithium (LiMnO₂) coin cell discharge curve is shown in Figure 12b.

Layout, Grounding, and Bypassing

For best performance, use PCBs. Board layout must ensure that digital and analog signal lines are separated from each other. Do not run analog and digital (especially clock) lines parallel to one another, or digital lines underneath the ADC package.

Figure 13 shows the recommended system ground connections. Establish a single-point analog ground (star ground point) at the MAX1391/MAX1394s' GND pin or use the ground plane.

High-frequency noise in the power supply (V_{DD}) degrades the ADC's performance. Bypass V_{DD} to GND with a 0.1 μ F capacitor as close to the device as possible. Minimize capacitor lead lengths for best supply noise rejection. To reduce the effects of supply noise, a 10 Ω resistor can be connected as a lowpass filter to attenuate supply noise.

Exposed Pad

The MAX1391/MAX1394 TDFN package has an exposed pad on the bottom of the package. This pad is not internally connected. Connect the exposed pad to the GND pin on the MAX1391/MAX1394 or leave floating for proper electrical performance.

Definitions

Integral Nonlinearity (INL)

INL is the deviation of the values on an actual transfer function from a straight line. For the MAX1391/MAX1394, this straight line is between the end points of the transfer function once offset and gain errors have been nullified. INL deviations are measured at every step and the worst-case deviation is reported in the *Electrical Characteristics* section.

1.5V to 3.6V, 416ksp/s, 1-Channel True-Differential/ 2-Channel Single-Ended, 8-Bit, SAR ADCs

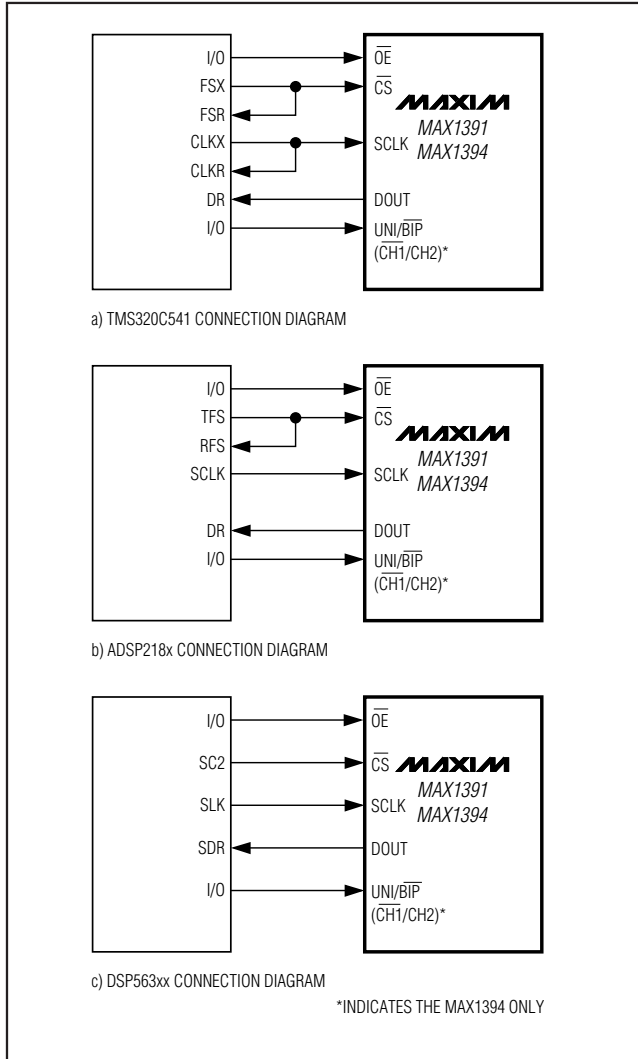

Figure 11. Common DSP Connections to the MAX1391/MAX1394

Differential Nonlinearity (DNL)

DNL is the difference between an actual step width and the ideal value of 1 LSB. A DNL error specification less than ± 1 LSB guarantees no missing codes and a monotonic transfer function. For the MAX1391/MAX1394, DNL deviations are measured at every step and the worst-case deviation is reported in the *Electrical Characteristics* section.

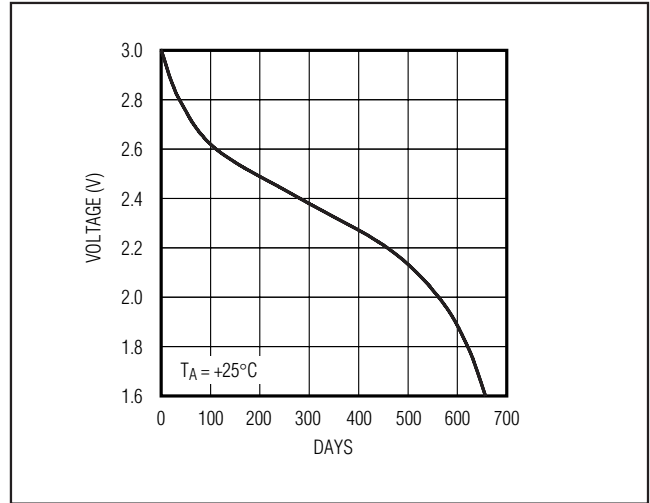

Figure 12a. Typical 2 x AA Discharge Curve at 100ksp/s

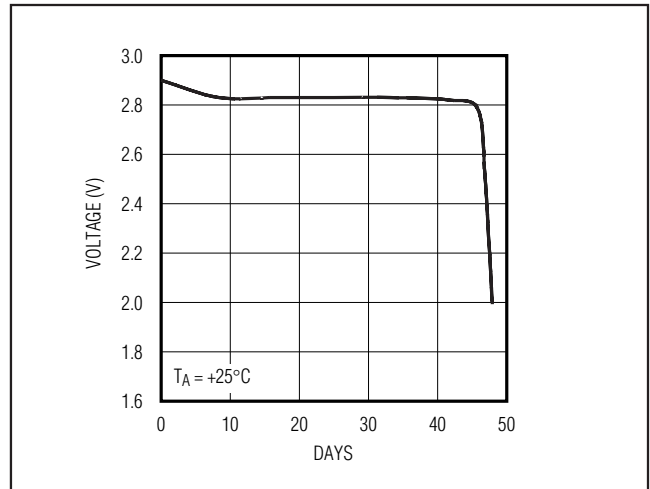

Figure 12b. Typical CR2032 Discharge Curve at 100ksp/s

Signal-to-Noise Plus Distortion (SINAD)

SINAD is computed by taking the ratio of the RMS signal to the RMS noise plus the RMS distortion. RMS noise includes all spectral components to the Nyquist frequency excluding the fundamental, the first five harmonics (HD2–HD6), and the DC offset. RMS distortion includes the first five harmonics (HD2–HD6).

$$\text{SINAD} = 20 \times \log \left(\frac{\text{SIGNAL}_{\text{RMS}}}{\sqrt{\text{NOISE}_{\text{RMS}}^2 + \text{DISTORTION}_{\text{RMS}}^2}} \right)$$

1.5V to 3.6V, 416ksps, 1-Channel True-Differential/ 2-Channel Single-Ended, 8-Bit, SAR ADCs

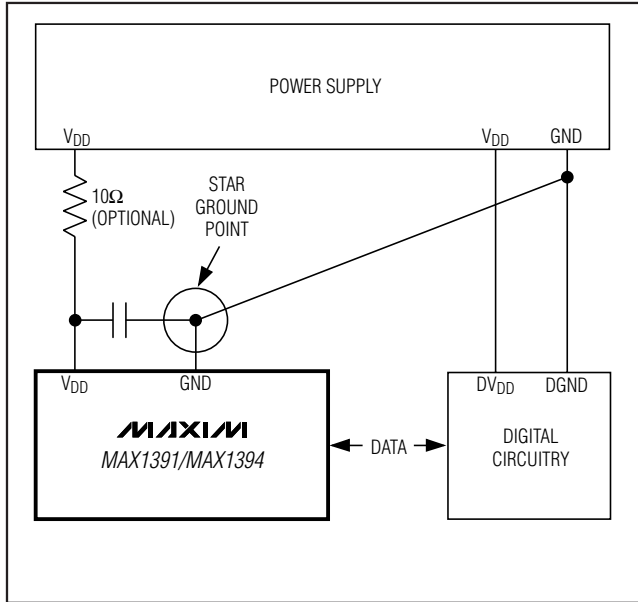

Figure 13. Power-Supply Grounding Connections

Signal-to-Noise Ratio (SNR)

SNR is a dynamic figure of merit that indicates the converter's noise performance. For a waveform perfectly reconstructed from digital samples, the theoretical maximum SNR is the ratio of the full-scale analog input (RMS value) to the RMS quantization error (residual error). The ideal, theoretical minimum analog-to-digital noise is caused by quantization error only and results directly from the ADC's resolution (N bits):

$$SNR_{dB[max]} = 6.02dB \times N + 1.76dB$$

In reality, there are other noise sources such as thermal noise, reference noise, and clock jitter that also degrade SNR. SNR is computed by taking the ratio of the RMS signal to the RMS noise. RMS noise includes all spectral components to the Nyquist frequency excluding the fundamental, the first five harmonics, and the DC offset.

Total Harmonic Distortion (THD)

THD is a dynamic figure of merit that indicates how much harmonic distortion the converter adds to the signal.

THD is the ratio of the RMS sum of the first five harmonics of the fundamental signal to the fundamental itself. This is expressed as:

$$THD = 20 \times \log \left(\frac{\sqrt{V_2^2 + V_3^2 + V_4^2 + V_5^2 + V_6^2}}{V_1} \right)$$

where V_1 is the fundamental amplitude, and V_2 through V_6 are the amplitudes of the 2nd- through 6th-order harmonics.

Spurious-Free Dynamic Range (SFDR)

SFDR is a dynamic figure of merit that indicates the lowest usable input signal amplitude. SFDR is the ratio of the RMS amplitude of the fundamental (maximum signal component) to the RMS value of the next-largest spurious component, excluding DC offset. SFDR is specified in decibels relative to the carrier (dBc).

Intermodulation Distortion (IMD)

IMD is the ratio of the RMS sum of the intermodulation products to the RMS sum of the two fundamental input tones. This is expressed as:

$$IMD = 20 \times \log \left(\frac{\sqrt{V_{IM1}^2 + V_{IM2}^2 + \dots + V_{IM3}^2 + V_{IMN}^2}}{\sqrt{V_1^2 + V_2^2}} \right)$$

The fundamental input tone amplitudes (V_1 and V_2) are at -6.5dBFS. 14 intermodulation products ($V_{IM_}$) are used in the MAX1391/MAX1394 IMD calculation. The intermodulation products are the amplitudes of the output spectrum at the following frequencies, where f_{IN1} and f_{IN2} are the fundamental input tone frequencies:

- 2nd-order intermodulation products:
 $f_{IN1} + f_{IN2}, f_{IN2} - f_{IN1}$
- 3rd-order intermodulation products:
 $2 \times f_{IN1} - f_{IN2}, 2 \times f_{IN2} - f_{IN1}, 2 \times f_{IN1} + f_{IN2}, 2 \times f_{IN2} + f_{IN1}$
- 4th-order intermodulation products:
 $3 \times f_{IN1} - f_{IN2}, 3 \times f_{IN2} - f_{IN1}, 3 \times f_{IN1} + f_{IN2}, 3 \times f_{IN2} + f_{IN1}$
- 5th-order intermodulation products:
 $3 \times f_{IN1} - 2 \times f_{IN2}, 3 \times f_{IN2} - 2 \times f_{IN1}, 3 \times f_{IN1} + 2 \times f_{IN2}, 3 \times f_{IN2} + 2 \times f_{IN1}$

Channel-to-Channel Crosstalk

Channel-to-channel crosstalk indicates how well each analog input is isolated from the others. The channel-to-channel crosstalk for the MAX1394 is measured by applying DC to channel 2 while a sine wave is applied to channel 1. An FFT is taken for channels 1 and 2, and the difference (in dB) is reported as the channel-to-channel crosstalk.

Aperture Delay

The MAX1391/MAX1394 sample data on the falling edge of its third SCLK cycle (Figure 14). In actuality, there is a small delay between the falling edge of the sampling clock and the actual sampling instant. Aperture delay (t_{AD}) is the time defined between the

1.5V to 3.6V, 416ksps, 1-Channel True-Differential/ 2-Channel Single-Ended, 8-Bit, SAR ADCs

falling edge of the sampling clock and the instant when an actual sample is taken.

Aperture Jitter

Aperture jitter (t_{AJ}) is the sample-to-sample variation in the aperture delay (Figure 14).

DC Power-Supply Rejection Ratio (PSRR)

DC PSRR is defined as the change in the positive full-scale transfer function point caused by a full range variation in the analog power-supply voltage (V_{DD}).

Chip Information

TRANSISTOR COUNT: 9106

PROCESS: BiCMOS

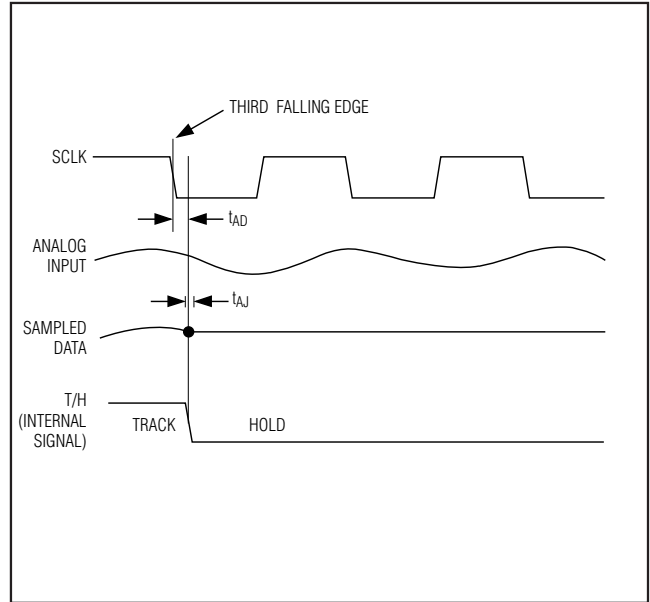
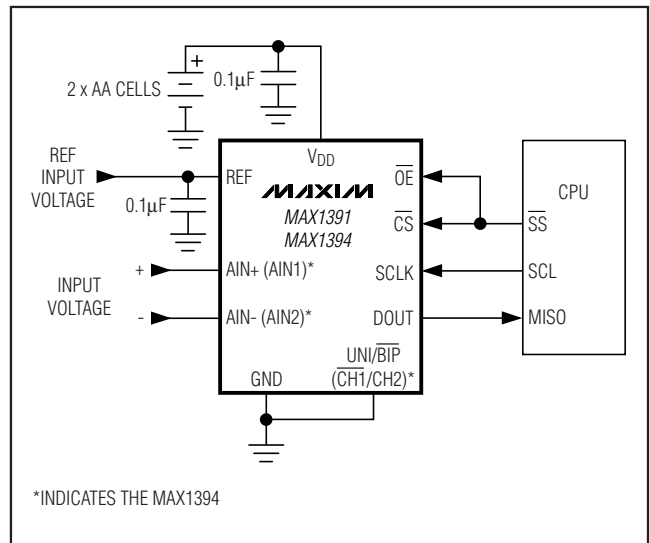

Figure 14. T/H Aperture Timing

Typical Operating Circuit



1.5V to 3.6V, 416ksps, 1-Channel True-Differential/ 2-Channel Single-Ended, 8-Bit, SAR ADCs

Pin Configurations

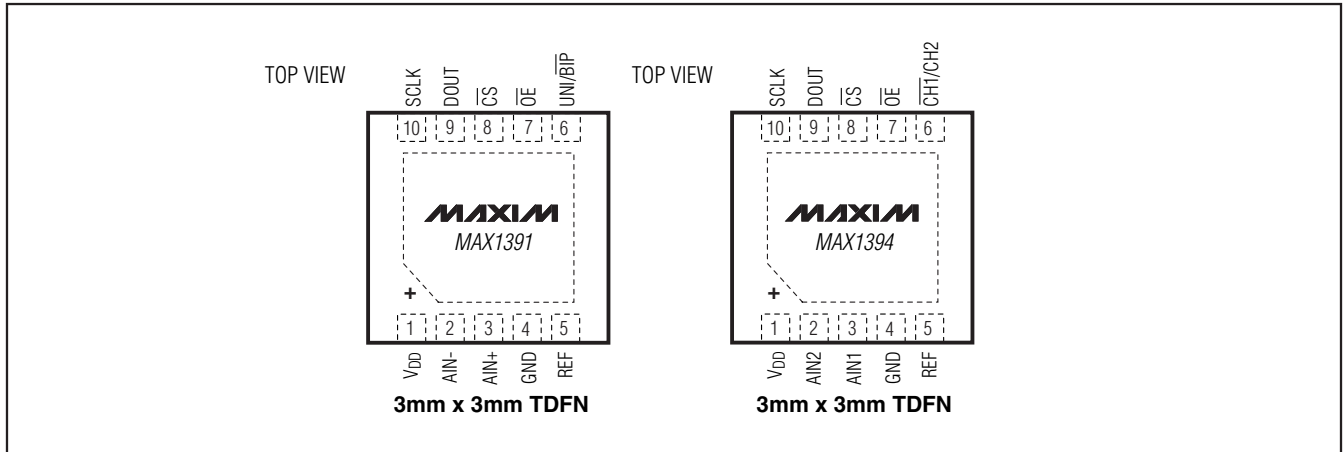

MAX1391/MAX1394

Package Information

For the latest package outline information and land patterns, go to www.maxim-ic.com/packages. Note that a "+", "#", or "-" in the package code indicates RoHS status only. Package drawings may show a different suffix character, but the drawing pertains to the package regardless of RoHS status.

PACKAGE TYPE	PACKAGE CODE	DOCUMENT NO.
10 TDFN-EP	T1033+1	21-0137

1.5V to 3.6V, 416ksps, 1-Channel True-Differential/ 2-Channel Single-Ended, 8-Bit, SAR ADCs

Revision History

REVISION NUMBER	REVISION DATE	DESCRIPTION	PAGES CHANGED
0	11/06	Initial release.	—
1	10/09	Removed the military grade packages from the <i>General Description</i> section, <i>Ordering Information</i> table, and <i>Absolute Maximum Ratings</i> section.	1, 2

Maxim cannot assume responsibility for use of any circuitry other than circuitry entirely embodied in a Maxim product. No circuit patent licenses are implied. Maxim reserves the right to change the circuitry and specifications without notice at any time.

18 **Maxim Integrated Products, 120 San Gabriel Drive, Sunnyvale, CA 94086 408-737-7600**

Looking for pricing, stock, or lifecycle information?

Click below to explore more details on WIN SOURCE:

- ⊖ [View MAX1394MTB+T on WIN SOURCE](#)
- ⊖ [Maxim Integrated Information](#)

Optimize Your Supply Chain with WIN SOURCE Solutions

- ✓ Global Sourcing Solution
- ✓ Obsolete Management
- ✓ Cost Control Management
- ✓ Shortage Management
- ✓ Alternative Solution
- ✓ Excess Inventory Management