



**THE DATASHEET OF  
MAX1414CAI+**





# Low-Power, 16-Bit Multichannel DAS with Internal Reference, 10-Bit DACs, and RTC

## General Description

The MAX1407/MAX1408/MAX1409/MAX1414 are low-power, general-purpose, multichannel data-acquisition systems (DAS). These devices are optimized for low-power applications. All the devices operate from a single +2.7V to +3.6V power supply and consume a maximum of 1.15mA in Run mode and only 2.5µA in Sleep mode.

The MAX1407/MAX1408/MAX1414 feature a differential 8:1 input multiplexer to the ADC, a programmable three-state digital output, an output to shutdown an external power supply, and a data ready output from the ADC. The MAX1408 has eight auxiliary analog inputs, while the MAX1407/MAX1414 include four auxiliary analog inputs and two 10-bit force/sense DACs. The MAX1414 features a 50mV trip threshold for the signal-detect comparator while the others have a 0mV trip threshold. The MAX1409 is a 20-pin version of the DAS family with a differential 4:1 input multiplexer to the ADC, one auxiliary analog input, and one 10-bit force/sense DAC.

The MAX1407/MAX1408/MAX1414 are available in space-saving 28-pin SSOP packages, while the MAX1409 is available in a 20-pin SSOP package.

## Applications

Medical Instruments  
Industrial Control Systems  
Portable Equipment  
Data-Acquisition System  
Automatic Testing  
Robotics

## Pin Configurations

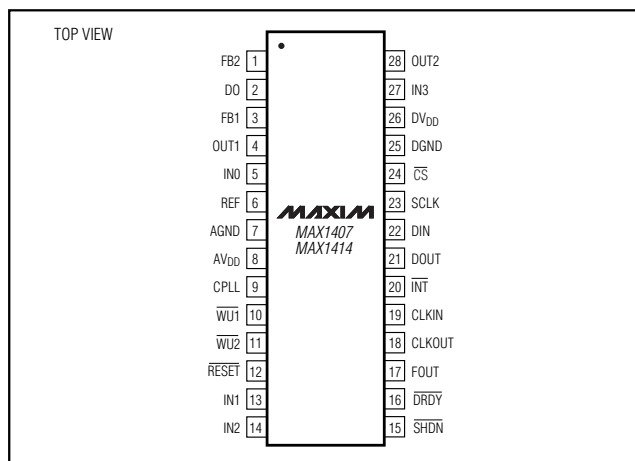

## Features

- ◆ +2.7V to +3.6V Supply Voltage Range in Standby, Idle, and Run Mode (Down to 1.8V in Sleep Mode)
- ◆ 1.15mA Run Mode Supply Current
- ◆ 2.5µA Sleep Mode Supply Current (Wake-Up, RTC, and Voltage Monitor Active)
- ◆ Multichannel 16-Bit Sigma-Delta ADC
  - ±1.5 LSB (typ) Integral Nonlinearity
  - 30Hz or 60Hz Continuous Conversion Rate
  - Buffered or Unbuffered Mode
  - Gain of +1/3, +1, or +2V/V
  - Unipolar or Bipolar Mode
  - On-Chip Offset Calibration
- ◆ 10-Bit Force/Sense DACs
- ◆ Buffered 1.25V, 18ppm/°C (typ) Bandgap Reference Output
- ◆ SPI™/QSPI™ or MICROWIRE™-Compatible Serial Interface
- ◆ System Support Functions
  - RTC (Valid til 9999) and Alarm
  - High-Frequency PLL Clock Output (2.4576MHz)
  - +1.8V and +2.7V  $\overline{\text{RESET}}$  and Power-Supply Voltage Monitors
  - Signal Detect Comparator
  - Interrupt Generator ( $\overline{\text{INT}}$  and  $\overline{\text{DRDY}}$ )
  - Three-State Digital Output
  - Wake-Up Circuitry
- ◆ 28-Pin SSOP (MAX1407/MAX1408/MAX1414), 20-Pin SSOP (MAX1409)

## Ordering Information

PART	TEMP. RANGE	PIN-PACKAGE
MAX1407CAI	0°C to +70°C	28 SSOP
MAX1408CAI	0°C to +70°C	28 SSOP
MAX1409CAP	0°C to +70°C	20 SSOP
MAX1414CAI	0°C to +70°C	28 SSOP

Pin Configurations continued at end of data sheet.  
Typical Operating Circuit appears at end of data sheet.

SPI and QSPI are trademarks of Motorola, Inc.  
MICROWIRE is a trademark of National Semiconductor Corp.



# Low-Power, 16-Bit Multichannel DAS with Internal Reference, 10-Bit DACs, and RTC

## ABSOLUTE MAXIMUM RATINGS

AV <sub>DD</sub> to AGND .....	-0.3V to +6V	Analog Outputs to AGND .....	-0.3V to +(AV <sub>DD</sub> + 0.3V)
AV <sub>DD</sub> to DV <sub>DD</sub> .....	-0.3V to +0.3V	Digital Outputs to DGND .....	-0.3V to +(AV <sub>DD</sub> + 0.3V)
Analog Inputs to AGND .....	-0.3V to +(AV <sub>DD</sub> + 0.3V)	REF to AGND .....	-0.3V to +(AV <sub>DD</sub> + 0.3V)
Digital Inputs to DGND .....	-0.3V to +6V	Operating Temperature Range:	
Maximum Current Input Into Any Pin .....	50mA	MAX14_CA_ .....	0°C to +70°C
Continuous Power Dissipation (T <sub>A</sub> = +70°C)		MAX14_EA_ .....	-40°C to +85°C
20-Pin SSOP (derate 8.0mW/°C above +70°C) .....	640mW	Lead Temperature (soldering, 10s) .....	+300 °C
28-Pin SSOP (derate 9.52mW/°C above +70°C) .....	762mW	Storage Temperature Range .....	-65°C to +150°C
DV <sub>DD</sub> to DGND .....	-0.3V to +6V	Junction Temperature .....	+150°C
AGND to DGND .....	-0.3V to +0.3V		

Stresses beyond those listed under "Absolute Maximum Ratings" may cause permanent damage to the device. These are stress ratings only, and functional operation of the device at these or any other conditions beyond those indicated in the operational sections of the specifications is not implied. Exposure to absolute maximum rating conditions for extended periods may affect device reliability.

## ELECTRICAL CHARACTERISTICS

(DV<sub>DD</sub> = AV<sub>DD</sub> = +2.7V to 3.6V, 4.7µF at REF, internal V<sub>REF</sub>, 18nF between CPLL and AV<sub>DD</sub>, 32.768kHz crystal across CLKIN and CLKOUT, T<sub>A</sub> = T<sub>MIN</sub> to T<sub>MAX</sub>, unless otherwise noted. Typical values are at T<sub>A</sub> = +25°C.)

PARAMETER	SYMBOL	CONDITIONS	MIN	TYP	MAX	UNITS
<b>ADC ACCURACY</b>						
Resolution (No Missing Codes)	RES		16			Bits
Integral Nonlinearity	INL	Unbuffered mode, Unipolar mode, gain = 1, V <sub>NEG</sub> = 0.2V, fully differential input (Note 7)		1.5	3.5	LSB
		Unbuffered mode, Unipolar mode, gain = 2, V <sub>NEG</sub> = 0.625V, pseudo-differential input		1.75		
		Unbuffered mode, Bipolar mode, gain = 1, V <sub>NEG</sub> = 0.625V, fully differential input		1.70		
		Buffered mode, Bipolar mode, gain = 2, V <sub>NEG</sub> = 0.625V, fully differential input		2.50		
Output RMS Noise (Note 1)	Unipolar	Gain = 2		±5		µV <sub>RMS</sub>
		Gain = 1		±10		
		Gain = 1/3		±30		
	Bipolar Mode	Gain = 2		±8		
		Gain = 1		±16.5		
		Gain = 1/3		±48.5		
Offset Error		On-chip calibration removes this error			±1	% of FSR
Offset Drift				±0.5		µV/°C
Gain Error		Excludes offset and reference errors			±1	% of FSR
Gain Drift		Excludes offset and reference errors			±1	ppm/°C

# Low-Power, 16-Bit Multichannel DAS with Internal Reference, 10-Bit DACs, and RTC

MAX1407/MAX1408/MAX1409/MAX1414

## ELECTRICAL CHARACTERISTICS (continued)

(DV<sub>DD</sub> = AV<sub>DD</sub> = +2.7V to 3.6V, 4.7μF at REF, internal V<sub>REF</sub>, 18nF between CPLL and AV<sub>DD</sub>, 32.768kHz crystal across CLKIN and CLKOUT, T<sub>A</sub> = T<sub>MIN</sub> to T<sub>MAX</sub>, unless otherwise noted. Typical values are at T<sub>A</sub> = +25°C.)

PARAMETER	SYMBOL	CONDITIONS		MIN	TYP	MAX	UNITS
PGA Gain		See <i>PGA Gain</i> section		1/3		V/V	
				1			
				2			
Power-Supply Rejection Ratio		Gain = 1, unipolar and buffered mode		70		dB	
Output Update Rate		Continuous conversion	RATE bit = 0	30		Hz	
			RATE bit = 1	60			
Turn-On Time		Excluding reference		50		μs	
<b>SIGNAL DETECT COMPARATOR</b>							
Differential Input-Detection Threshold Voltage		MAX1407/MAX1408/MAX1409		-10	0	10	mV
		MAX1414		44	50	56	
Common-Mode Input Voltage				0	0.8		V
Turn-On Time				10		μs	
<b>ANALOG INPUTS</b>							
Differential Input Voltage Range		Unipolar mode	ADC gain = 1	0	V <sub>REF</sub>		V
			ADC gain = 2	0	V <sub>REF</sub> /2		
			ADC gain = 1/3	0	AV <sub>DD</sub>		
		Bipolar mode	ADC gain = 1	-V <sub>REF</sub>	V <sub>REF</sub>		
			ADC gain = 2	-V <sub>REF</sub> /2	V <sub>REF</sub> /2		
			ADC gain = 1/3	-AV <sub>DD</sub>	AV <sub>DD</sub>		
Absolute Input Voltage Range		Unbuffered		-0.05	AV <sub>DD</sub>		V
		Buffered		0.05	1.40		
Common-Mode Input Voltage Range		Unbuffered		AGND	AV <sub>DD</sub>		V
		Buffered		0.05	1.40		
Common-Mode Rejection Ratio		Gain = 1, unipolar and buffered mode		90		dB	
Input Sampling Rate		F <sub>OUT</sub> = 2.4576MHz	30Hz data rate	15.360		kHz	
			60Hz data rate	30.720			
Input Current		Buffered mode		±0.5		nA	
Input Capacitance				15		pF	
<b>FORCE-SENSE DAC</b> (all measurements made with FB1(2) shorted to OUT1(2), unless otherwise noted). (MAX1407/MAX1409/MAX1414 only)							
Resolution				10			Bits
Differential Nonlinearity		Guaranteed monotonic (Note 2)		±1.0		LSB	
Integral Nonlinearity		(Note 2)		±1.0		LSB	
Offset Error		(Note 3)		±20		mV	
Offset Drift				±5		μV/°C	
Gain Error		Excludes offset and reference drift		3.6		mV	
Gain Drift		Excludes offset and reference drift		10		ppm/°C	
Line Regulation				190		μV/V	
Current into FB1(2)				±0.5		nA	

# Low-Power, 16-Bit Multichannel DAS with Internal Reference, 10-Bit DACs, and RTC

## ELECTRICAL CHARACTERISTICS (continued)

(DV<sub>DD</sub> = AV<sub>DD</sub> = +2.7V to 3.6V, 4.7μF at REF, internal V<sub>REF</sub>, 18nF between CPLL and AV<sub>DD</sub>, 32.768kHz crystal across CLKIN and CLKOUT, T<sub>A</sub> = T<sub>MIN</sub> to T<sub>MAX</sub>, unless otherwise noted. Typical values are at T<sub>A</sub> = +25°C.)

PARAMETER	SYMBOL	CONDITIONS	MIN	TYP	MAX	UNITS	
Output Slew Rate		010hex to 3FFhex and 3FFhex to 010hex code swing, R <sub>L</sub> = 12kΩ, C <sub>L</sub> = 200pF		18.0		V/ms	
Output Settling Time		To ±1/2 LSB (at 10-bit accuracy) of full-scale with code transition from 010hex to 3FFhex, R <sub>L</sub> = 12kΩ, C <sub>L</sub> = 200pF		65		μs	
Turn-On Time				100		μs	
OUT1, OUT2 Output Range		No Load (Note 4)	0.05		AV <sub>DD</sub> - 0.2	V	
<b>EXTERNAL REFERENCE</b> (internal reference powered down)							
Input Voltage Range				1.25 ±0.10		V	
Input Resistance				540		kΩ	
Input Current				2.3		μA	
<b>INTERNAL REFERENCE</b> (AV <sub>DD</sub> = 3V, unless otherwise noted)							
Output Voltage		T <sub>A</sub> = +25°C	1.225	1.25	1.275	V	
Output Voltage Temperature Coefficient				18		ppm/°C	
Output Short-Circuit Current				3.4		mA	
Line Regulation	ΔV <sub>REF</sub> /ΔV <sub>DD</sub>	2.7 < AV <sub>DD</sub> < 3.6V		80		μV/V	
Load Regulation		I <sub>SOURCE</sub> = 0μA to 500μA, T <sub>A</sub> = +25°C			1	μV/μA	
		I <sub>SINK</sub> = 0μA to 50μA, T <sub>A</sub> = +25°C			2		
Noise Voltage	e <sub>OUT</sub>	0.1Hz to 10Hz		40		μVp-p	
		10Hz to 10kHz		400			
Power-Supply Rejection Ratio		±100mV, f = 120Hz		70		dB	
Turn-On Time				3		ms	
<b>μP RESET</b>							
Supply Voltage Range		For valid RESET	1		3.6	V	
RESET Trip Threshold Low	V <sub>TH</sub>	AV <sub>DD</sub> falling	Bit VM = 1	1.800	1.865	1.930	V
			Bit VM = 0	2.70	2.75	2.80	
Low AV <sub>DD</sub> Trip Threshold		For Normal, Idle, and Standby modes, AV <sub>DD</sub> falling	2.70	2.75	2.80	V	
RESET Output Low Voltage (Open-Drain Output)		I <sub>SINK</sub> = 1mA, AV <sub>DD</sub> = 1.8V			0.4	V	

# Low-Power, 16-Bit Multichannel DAS with Internal Reference, 10-Bit DACs, and RTC

MAX1407/MAX1408/MAX1409/MAX1414

## ELECTRICAL CHARACTERISTICS (continued)

(DVDD = AVDD = +2.7V to 3.6V, 4.7μF at REF, internal VREF, 18nF between CPLL and AVDD, 32.768kHz crystal across CLKIN and CLKOUT, TA = TMIN to TMAX, unless otherwise noted. Typical values are at TA = +25°C.)

PARAMETER	SYMBOL	CONDITIONS	MIN	TYP	MAX	UNITS
RESET Output Leakage		AVDD ≥ VTH, RESET deasserted		0.002	0.1	μA
Turn-On Time				2		ms
<b>CRYSTAL OSCILLATOR</b>						
Crystal Frequency		AVDD = +3V		32.768		kHz
Crystal Load Capacitance				6		pF
Oscillator Stability		AVDD = +1.8V to +3.6V, excluding crystal		0		ppm/V
Oscillator Startup Time				1.5		s
<b>PLL</b>						
FOUT Frequency		AVDD = +3V		2.4576		MHz
Absolute Clock Jitter		Cycle-to-cycle		10		ns
Frequency Tolerance/Stability		Overtemperature excluding crystal, TA = TMIN to TMAX		0		ppm/°C
		Oversupply voltage, +2.7V < AVDD < +3.6V		0		ppm/mV
FOUT Rise/Fall Time		20% to 80% waveform, CL = 30pF		15	30	ns
Duty Cycle			40	50	60	%
<b>DIGITAL INPUTS (DIN, SCLK, CS, WU1, WU2)</b>						
Input High Voltage		DVDD = +1.8V to +3.6V	0.7 x DVDD			V
Input Low Voltage		DVDD = +1.8V to +3.6V			0.3 x DVDD	V
Input Hysteresis		DVDD = +3V		200		mV
DIN, SCLK, CS, Input Current		VIN = 0 or VIN = DVDD		±0.01	±10	μA
WU1, WU2 Input Current		VIN = AVDD		0.01	10	μA
WU1, WU2 Pullup Current		VIN = 0		10		μA
Input Capacitance				10		pF
<b>DIGITAL OUTPUTS (DOUT, FOUT, INT, DRDY, SHDN, D0)</b>						
DOUT, FOUT, DRDY, INT Output Low Voltage	VOL	ISINK = 1mA, DVDD = +1.8V to +3.6V			0.4	V
DOUT, FOUT, DRDY, INT, SHDN Output High Voltage	VOH	ISOURCE = 0.2mA, DVDD = +1.8V to +3.6V	0.8 x DVDD			V
DOUT Three-State Leakage				±0.01	±10	μA
DOUT Three-State Capacitance				15		pF
SHDN Output Low Voltage (MAX1407/MAX1408/MAX1414 only)		ISINK = 1mA, DVDD = +1.8V to +3.6V			0.4	V
		ISINK = 50μA, DVDD = +1.8V to +3.6V			0.04 x DVDD	

# Low-Power, 16-Bit Multichannel DAS with Internal Reference, 10-Bit DACs, and RTC

## ELECTRICAL CHARACTERISTICS (continued)

(DV<sub>DD</sub> = AV<sub>DD</sub> = +2.7V to 3.6V, 4.7μF at REF, internal V<sub>REF</sub>, 18nF between CPLL and AV<sub>DD</sub>, 32.768kHz crystal across CLKIN and CLKOUT, T<sub>A</sub> = T<sub>MIN</sub> to T<sub>MAX</sub>, unless otherwise noted. Typical values are at T<sub>A</sub> = +25°C.)

PARAMETER	SYMBOL	CONDITIONS	MIN	TYP	MAX	UNITS
D0 Output Low Voltage (MAX1407/MAX1408/MAX1414 only)		I <sub>SINK</sub> = 200μA, DV <sub>DD</sub> = +2.7V to +3.6V			0.7	mV
D0 Output High Voltage (MAX1407/MAX1408/MAX1414 only)		I <sub>SOURCE</sub> = 2mA, DV <sub>DD</sub> = +2.7V to +3.6V	DV <sub>DD</sub> - 0.1			V
<b>POWER REQUIREMENTS</b>						
Supply Voltage Range	V <sub>DD</sub>	Run, Idle, and Standby mode	2.7		3.6	V
		Sleep mode	1.8		3.6	
Supply Current (Note 5)	I <sub>DD</sub>	Run mode	MAX1407/MAX1414		1.15	mA
			MAX1408		1.03	
			MAX1409		1.09	
		Idle mode	MAX1407/MAX1414		650	μA
			MAX1408		530	
			MAX1409		590	
		Standby mode	MAX1407/MAX1408/ MAX1409/MAX1414		330	
Sleep mode V <sub>DD</sub> = 2.7V	MAX1407/MAX1408/ MAX1409/MAX1414	1.7	2.5			

## TIMING CHARACTERISTICS

(MAX1407/MAX1408/MAX1409/MAX1414: AV<sub>DD</sub> = DV<sub>DD</sub> = 2.7V to 3.6V, T<sub>A</sub> = T<sub>MIN</sub> to T<sub>MAX</sub>, unless otherwise noted.)

PARAMETER	SYMBOL	CONDITIONS	MIN	TYP	MAX	UNITS
<b>TIMING PARAMETERS</b>						
SCLK Operating Frequency	f <sub>SCLK</sub>				2.1	MHz
SCLK Cycle Time	t <sub>CYC</sub>		476			ns
SCLK Pulse Width High	t <sub>CH</sub>		190			ns
SCLK Pulse Width Low	t <sub>CL</sub>		190			ns
DIN to SCLK Setup	t <sub>DS</sub>		100			ns
DIN to SCLK Hold	t <sub>DH</sub>		0			ns
SCLK Fall to Output Data Valid	t <sub>DO</sub>	C <sub>L</sub> = 50pF (see load circuit)			200	ns
$\overline{\text{CS}}$ Fall to Output Enable	t <sub>DV</sub>	C <sub>L</sub> = 50pF (see load circuit)			240	ns
$\overline{\text{CS}}$ Rise to Output Disable	t <sub>TR</sub>	C <sub>L</sub> = 50pF (see load circuit)			240	ns
$\overline{\text{CS}}$ to SCLK Rise Setup	t <sub>CSS</sub>		100			ns
$\overline{\text{CS}}$ to SCLK Rise Hold	t <sub>CSH</sub>		0			ns

# Low-Power, 16-Bit Multichannel DAS with Internal Reference, 10-Bit DACs, and RTC

MAX1407/MAX1408/MAX1409/MAX1414

## TIMING CHARACTERISTICS (continued)

(MAX1407/MAX1408/MAX1409/MAX1414:  $AV_{DD} = DV_{DD} = 2.7V$  to  $3.6V$ ,  $T_A = T_{MIN}$  to  $T_{MAX}$ , unless otherwise noted.)

PARAMETER	SYMBOL	CONDITIONS	MIN	TYP	MAX	UNITS
<b>TYPICAL TIMING PARAMETERS</b>						
OUT1/OUT2 Turn-Off Time		Input impedance > $1M\Omega$ (MAX1407/MAX1409/MAX1414 only)		100		$\mu s$
Sleep Voltage Monitor Timeout Period	$t_{DSLP}$	The delay for the sleep voltage monitor output, $\overline{RESET}$ , to go high after $AV_{DD}$ rises above the reset threshold (+1.8V when bit VM = 1 and +2.7V, when bit VM = 0); this is largely driven by the startup of the 32kHz oscillator		1.54		s
$\overline{WU1}$ or $\overline{WU2}$ Pulse Width	$t_{WU}$	Minimum pulse width required to detect a wake-up event		1		$\mu s$
Shutdown Deassert Delay	$t_{DPU}$	The delay for $\overline{SHDN}$ to go high after a valid wake-up event		1		$\mu s$
FOUT Turn-On Time	$t_{DFON}$	The turn-on time for the high-frequency clock; it is gated by an AND function with three signals—the $\overline{RESET}$ signal, the internal low voltage $V_{DD}$ monitor signal, and the assertion of the PLL; the time delay is timed from when the low-voltage monitor trips or the $\overline{RESET}$ going high, whichever happens later; FOUT always starts in the low state		31.25		ms
$\overline{INT}$ Delay	$t_{DFI}$	The delay for $\overline{INT}$ to go low after the FOUT clock output has been enabled; $\overline{INT}$ is used as an interrupt signal to inform the $\mu P$ the high-frequency clock has started		7.82		ms
FOUT Disable Delay	$t_{DFOF}$	The delay after a shutdown command has asserted and before FOUT is disabled; this gives the microcontroller time to clean up and go into Sleep mode properly		1.95		ms
$\overline{SHDN}$ Assertion Delay	$t_{DPD}$	The delay after a shutdown command has asserted and before $\overline{SHDN}$ is pulled low (turning off the DC-DC converter) (Note 6)		2.93		ms

**Note 1:** Single conversion.

**Note 2:** DNL and INL are measured between code 010hex and 3FFhex.

**Note 3:** Offset error is referenced to code 010hex.

**Note 4:** Output swing is a function of external gain-setting feedback resistors and REF voltage.

**Note 5:** Measured with no load on FOUT, DOUT, and the DAC amplifiers. SCLK is idle, and all digital inputs are at DGND or  $DV_{DD}$ .

**Note 6:**  $\overline{SHDN}$  stays high if the PLL is on.

**Note 7:** Actual worst-case performance is  $\pm 2.5LSB$ . Guaranteed limit of  $\pm 3.5LSB$  is due to production test limitation.

**Note 8:** Guaranteed by design. Not production tested.

# Low-Power, 16-Bit Multichannel DAS with Internal Reference, 10-Bit DACs, and RTC

## Load Circuits

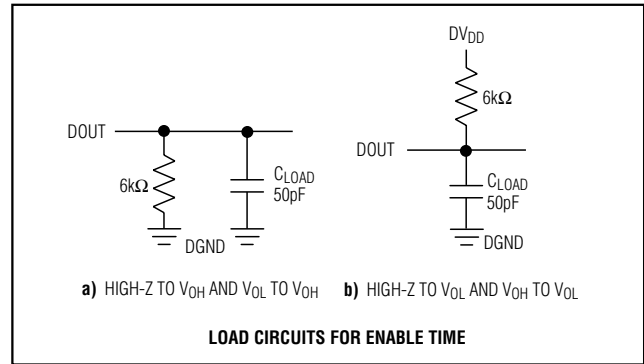
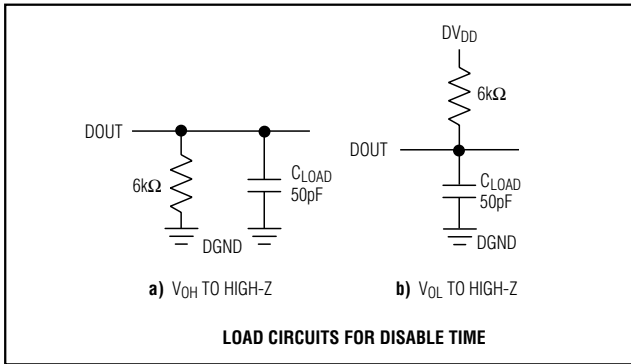

## Typical Operating Characteristics

( $V_{DD} = V_{VDD} = 3V$ , MAX1407 used,  $T_A = +25^\circ C$ , unless otherwise noted.)

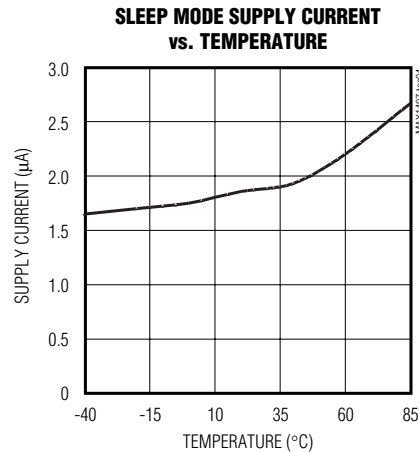
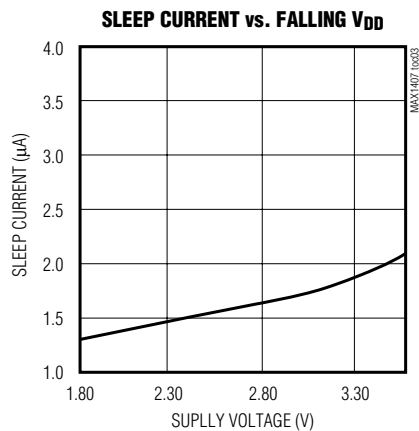
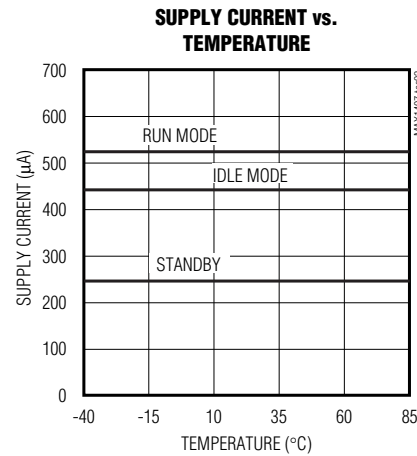
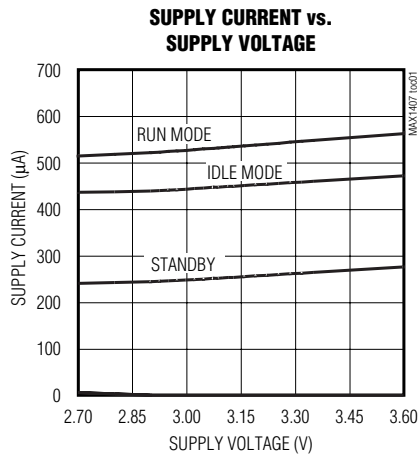

# Low-Power, 16-Bit Multichannel DAS with Internal Reference, 10-Bit DACs, and RTC

## Typical Operating Characteristics (continued)

( $V_{DD} = D_{VDD} = 3V$ , MAX1407 used,  $T_A = +25^\circ C$ , unless otherwise noted.)

MAX1407/MAX1408/MAX1409/MAX1414

**MAXIMUM INL vs.  $V_{DD}$**   
(UNIPOLAR MODE,  $T = +25^\circ C$ ,  
PSEUDO-DIFFERENTIAL INPUT)

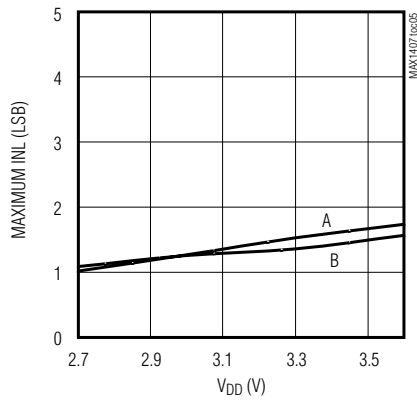

A: GAIN = 1, UNBUFFERED MODE, 60sps  
B: GAIN = 1, UNBUFFERED MODE, 30sps

**MAXIMUM INL vs.  $V_{DD}$**   
(BIPOLAR MODE,  $T = +25^\circ C$ ,  
FULLY DIFFERENTIAL INPUT)

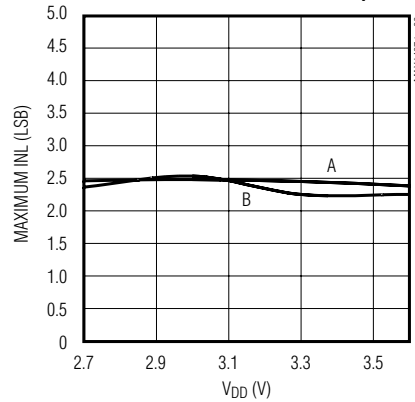

A: GAIN = 2, BUFFERED MODE, 60sps  
B: GAIN = 2, BUFFERED MODE, 30sps

**MAXIMUM INL vs. TEMPERATURE**  
(UNIPOLAR MODE,  $V_{DD} = 3V$ ,  
PSEUDO-DIFFERENTIAL INPUT)

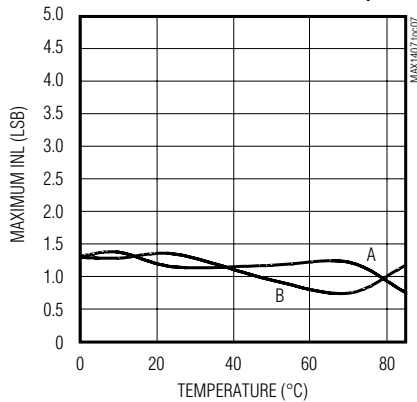

A: GAIN = 1, UNBUFFERED MODE, 60sps  
B: GAIN = 1, UNBUFFERED MODE, 30sps

**MAXIMUM INL vs. TEMPERATURE**  
(BIPOLAR MODE,  $V_{DD} = 3V$ ,  
FULLY DIFFERENTIAL INPUT)

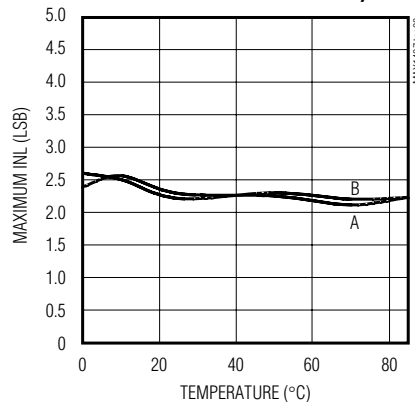

A: GAIN = 2, BUFFERED MODE, 60sps  
B: GAIN = 2, BUFFERED MODE, 30sps

# Low-Power, 16-Bit Multichannel DAS with Internal Reference, 10-Bit DACs, and RTC

## Typical Operating Characteristics (continued)

( $V_{DD} = D_{VDD} = 3V$ , MAX1407 used,  $T_A = +25^\circ C$ , unless otherwise noted.)

**MAXIMUM INL vs. COMMON-MODE INPUT VOLTAGE (BIPOLAR MODE, BUFFERED MODE,  $V_{DD} = 2.7V$ , 30sps, FULLY DIFFERENTIAL INPUT,  $T = +25^\circ C$ )**

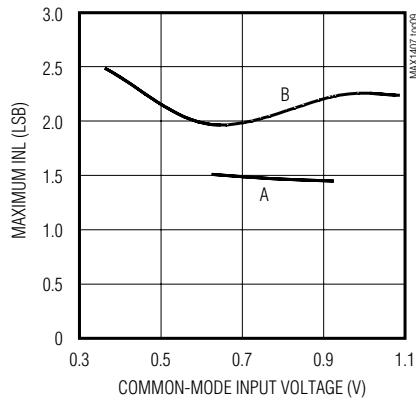

A: GAIN = 1  
B: GAIN = 2

**INL vs. FULLY DIFFERENTIAL INPUT VOLTAGE (BIPOLAR MODE, GAIN = 1, UNBUFFERED MODE,  $V_{CM} = 0.625V$ ,  $V_{DD} = 3V$ ,  $T = +25^\circ C$ )**

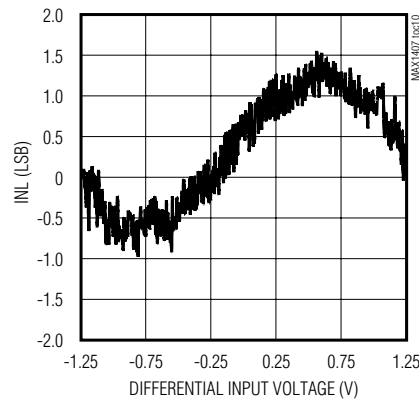

**INL vs. PSEUDO-DIFFERENTIAL INPUT VOLTAGE RANGE (UNIPOLAR MODE, GAIN = 1, UNBUFFERED MODE,  $V_{NEG} = 0$ ,  $V_{DD} = 3V$ ,  $T = +25^\circ C$ )**

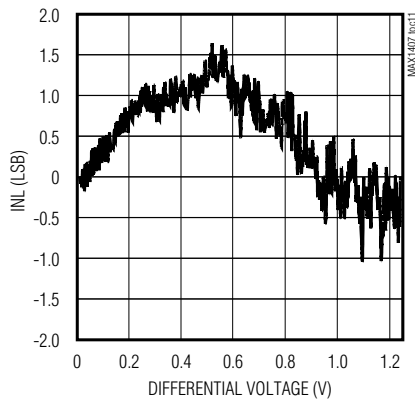

**UNCORRECTED OFFSET ERROR vs. TEMPERATURE (UNBUFFERED MODE,  $V_{DD} = 3V$ )**

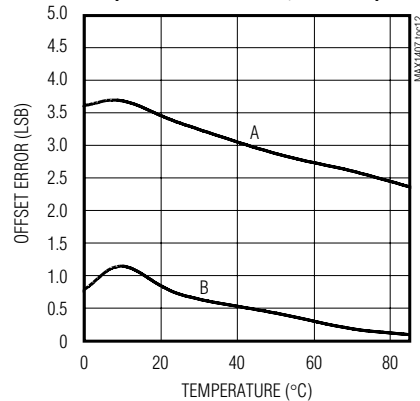

A: GAIN = 1, UNIPOLAR MODE  
B: GAIN = 2, BIPOLAR MODE

# Low-Power, 16-Bit Multichannel DAS with Internal Reference, 10-Bit DACs, and RTC

## Typical Operating Characteristics (continued)

( $V_{DD} = D_{VDD} = 3V$ , MAX1407 used,  $T_A = +25^\circ C$ , unless otherwise noted.)

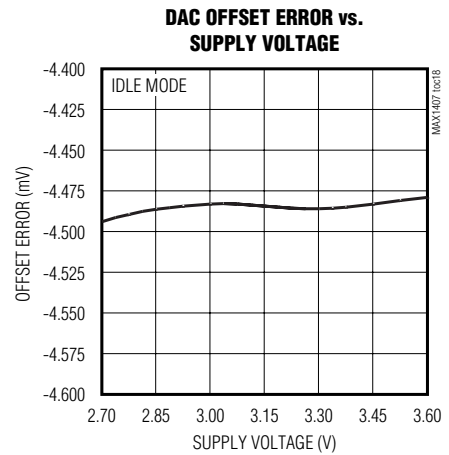
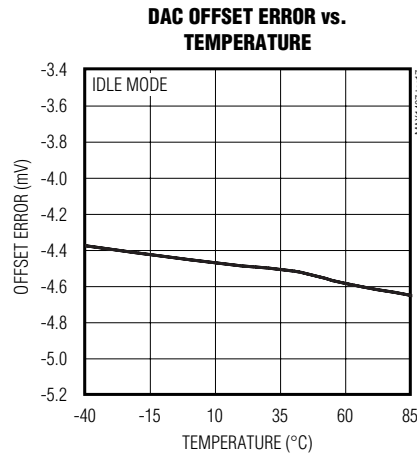
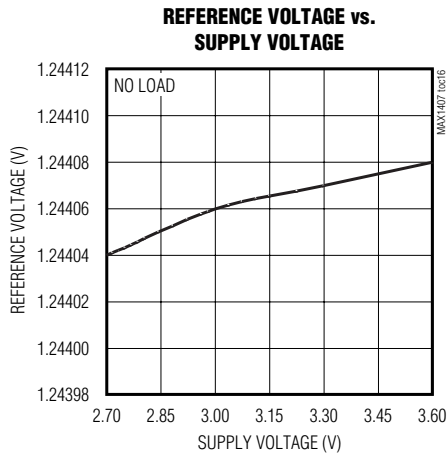
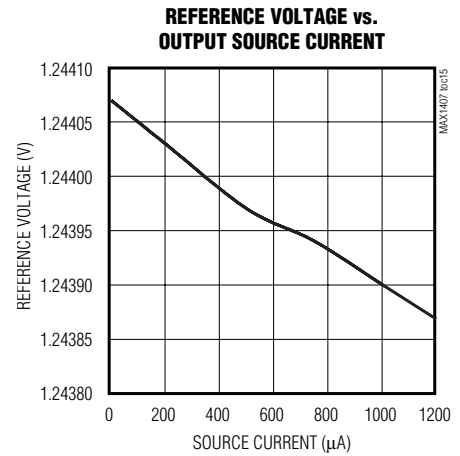
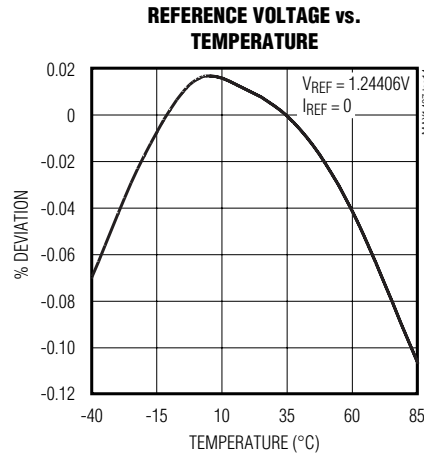
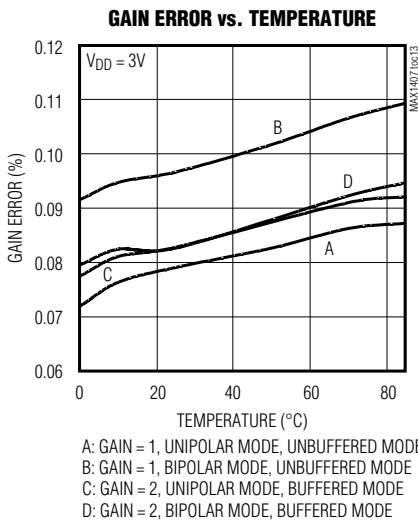

MAX1407/MAX1408/MAX1409/MAX1414

# Low-Power, 16-Bit Multichannel DAS with Internal Reference, 10-Bit DACs, and RTC

## Typical Operating Characteristics (continued)

( $V_{DD} = D_{VDD} = 3V$ , MAX1407 used,  $T_A = +25^\circ C$ , unless otherwise noted.)

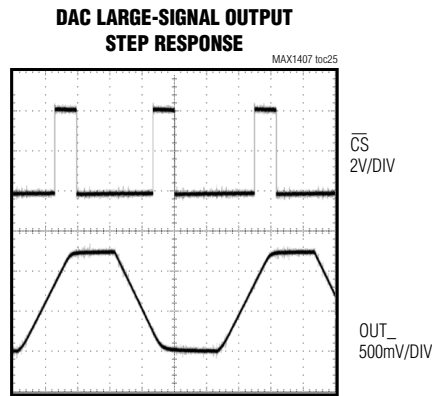
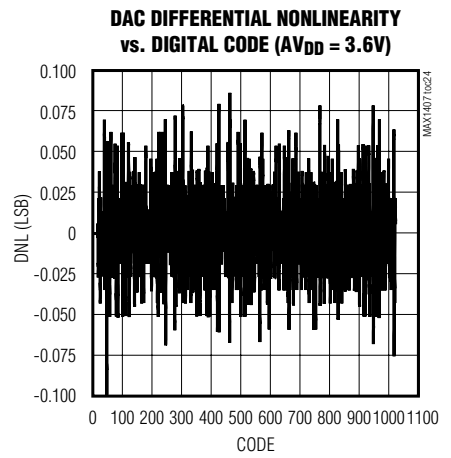
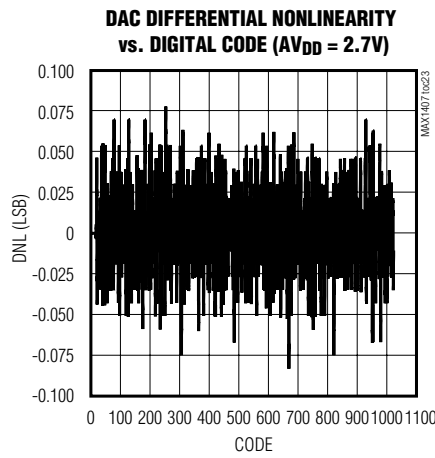
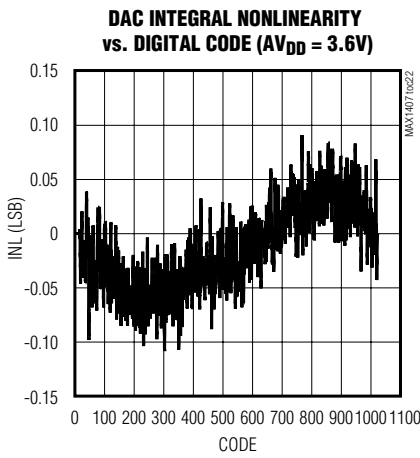
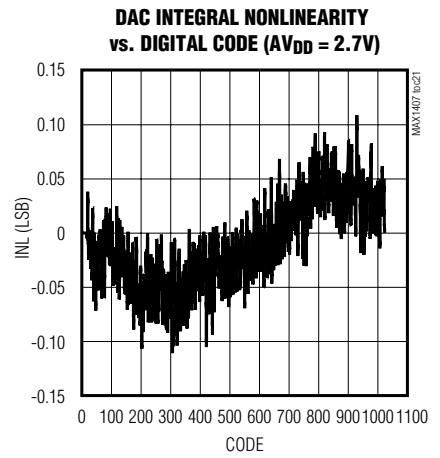
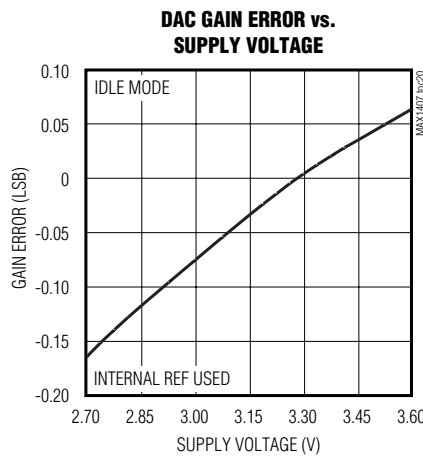
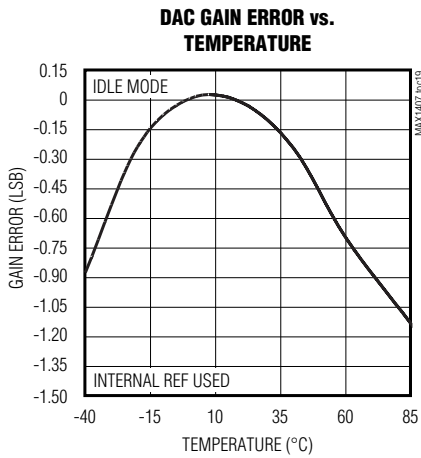

$V_{REF} = 1.25V$ ,  $A_{VDD} = 3.0V$ ,  $R_L = 0$

# Low-Power, 16-Bit Multichannel DAS with Internal Reference, 10-Bit DACs, and RTC

## Typical Operating Characteristics (continued)

( $A_{VDD} = D_{VDD} = 3V$ , MAX1407 used,  $T_A = +25^\circ C$ , unless otherwise noted.)

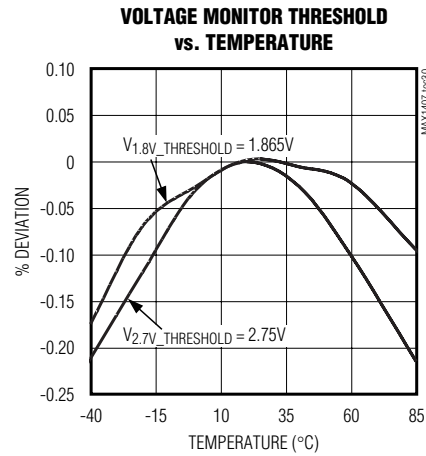
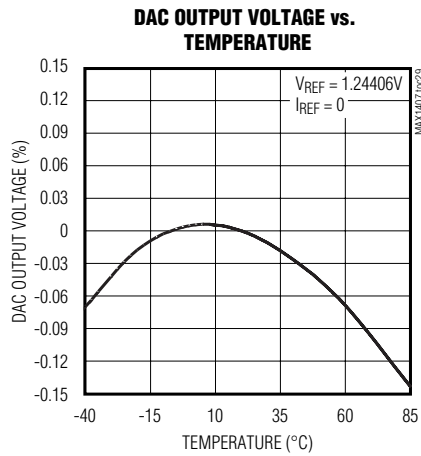
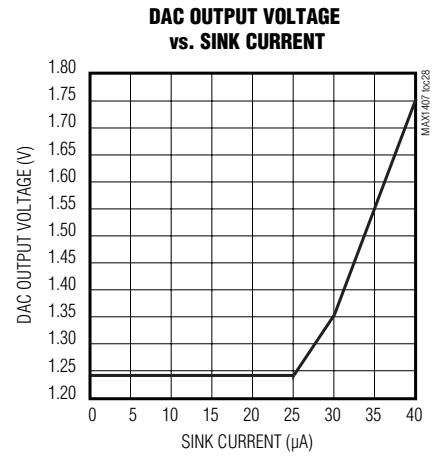
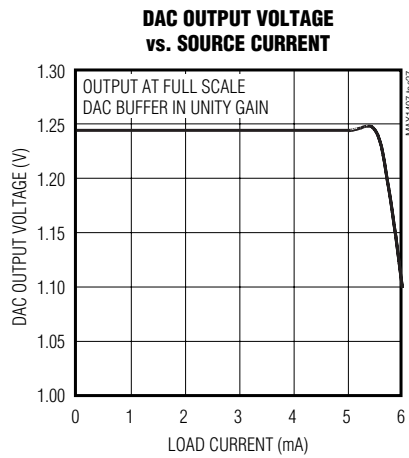
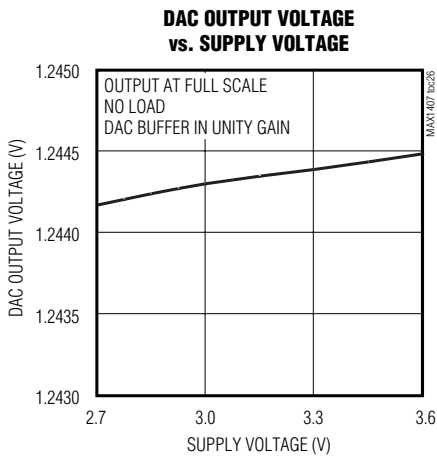

MAX1407/MAX1408/MAX1409/MAX1414

# Low-Power, 16-Bit Multichannel DAS with Internal Reference, 10-Bit DACs, and RTC

## Pin Description

MAX1407 MAX1414	MAX1408	MAX1409	PIN	FUNCTION
1	—	—	FB2	Force/Sense DAC2 Feedback Input
—	1	—	IN7	Analog Input. Analog input to the negative mux only.
—	—	1	FB1	Force/Sense DAC1 Feedback Input
2	2	—	D0	Digital Output. Three-state general-purpose digital output.
3	—	—	FB1	Force/Sense DAC1 Feedback Input
—	3	—	IN6	Analog Input. Analog input to the negative mux only.
4	—	2	OUT1	Force/Sense DAC1 Output
—	4	—	IN4	Analog Input. Analog input to the positive mux only.
5	5	3	IN0	Analog Input. Analog input to both the positive and negative mux.
6	6	4	REF	1.25V Reference Buffer Output/External Reference Input. Reference voltage for the ADC and the DAC. Connect a 4.7 $\mu$ F capacitor to REF between REF and AGND.
7	7	5	AGND	Analog Ground. Reference point for the analog circuitry. AGND connects to the IC substrate.
8	8	6	AV <sub>DD</sub>	Analog Supply Voltage
9	9	7	CPLL	PLL Capacitor Connection Pin. Connect an 18nF ceramic capacitor between CPLL and AV <sub>DD</sub> .
10	10	8	$\overline{\text{WU1}}$	Active-Low Wake-Up Input. Internally pulled up. The device will wake-up from Sleep mode to Standby mode when WU1 is asserted.
11	11	9	$\overline{\text{WU2}}$	Active-Low Wake-Up Input. Internally pulled up. The device will wake-up from Sleep mode to Standby mode when WU2 is asserted.
12	12	10	$\overline{\text{RESET}}$	Active-Low RESET Output. It remains low while AV <sub>DD</sub> is below the threshold and stays low for a timeout period after AV <sub>DD</sub> rises above the threshold. $\overline{\text{RESET}}$ is an open-drain output.
13	13	—	IN1	Analog Input. Analog input to both the positive and negative mux.
14	14	—	IN2	Analog Input. Analog input to both the positive and negative mux.
15	15	—	$\overline{\text{SHDN}}$	Programmable Shutdown Output. Goes low in Sleep mode.
16	16	—	$\overline{\text{DRDY}}$	Active-Low Data Ready Output. A logic low indicates that a new conversion result is available in the Data register. $\overline{\text{DRDY}}$ returns high upon completion of a full output word read operation. $\overline{\text{DRDY}}$ also signals the end of an ADC offset-calibration.
17	17	11	FOUT	2.4576MHz Clock Output. FOUT can be used to drive the input clock of a $\mu$ P.
18	18	12	CLKOUT	32kHz Crystal Output. Connect a 32kHz crystal between CLKIN and CLKOUT.
19	19	13	CLKIN	32kHz Crystal Input. Connect a 32kHz crystal between CLKIN and CLKOUT.

# Low-Power, 16-Bit Multichannel DAS with Internal Reference, 10-Bit DACs, and RTC

## Pin Description (continued)

MAX1407 MAX1414	MAX1408	MAX1409	PIN	FUNCTION
20	20	14	$\overline{\text{INT}}$	Active-Low Interrupt Output. $\overline{\text{INT}}$ goes low when the PLL output is ready, when the signal-detect comparator is tripped, or when the alarm is triggered.
21	21	15	DOUT	Serial Data Output. DOUT outputs serial data from the internal shift register on SCLK's falling edge. When $\overline{\text{CS}}$ is high, DOUT is three-stated.
22	22	16	DIN	Serial Data Input. Data on DIN is written to the input shift register and is clocked in at SCLK's rising edge when $\overline{\text{CS}}$ is low.
23	23	17	SCLK	Serial Clock Input. Apply an external serial clock to transfer data to and from the device. This serial clock can be continuous, with data transmitted in a train of pulses, or intermittent while $\overline{\text{CS}}$ is low.
24	24	18	$\overline{\text{CS}}$	Active-Low Chip-Select Input. $\overline{\text{CS}}$ is used to select the active device in systems with more than one device on the serial bus. Data will not be clocked into DIN unless $\overline{\text{CS}}$ is low. When $\overline{\text{CS}}$ is high, DOUT is three-stated.
25	25	19	DGND	Digital Ground. Reference point for digital circuitry.
26	26	20	DVDD	Digital Supply Voltage
27	27	—	IN3	Analog Input. Analog input to both the positive and negative mux.
28	—	—	OUT2	Force/Sense DAC2 Output
—	28	—	IN5	Analog Input. Analog input to the positive mux only.

### Detailed Information

The MAX1407/MAX1408/MAX1409/MAX1414 are low-power, general-purpose, multichannel DAS featuring a multiplexed fully differential 16-bit  $\Sigma\Delta$  analog-to-digital converter (ADC), 10-bit force/sense digital-to-analog converters (DAC), a real-time clock (RTC) with an alarm, a bandgap voltage reference, a signal detect comparator, two power-supply voltage monitors, wake-up control circuitry, and a high-frequency phase-locked loop (PLL) clock output all controlled by a 3-wire serial interface. (See Table 1 for the MAX1407/MAX1408/

MAX1409/MAX1414 feature sets and Figures 1, 2, 3 for the *Functional Diagrams*). These DAS directly interface to various sensor outputs and once configured provide the stimulus, conditioning, and data conversion, as well as microprocessor support. Figure 4 is a *Typical Application Circuit* for the MAX1407/MAX1414.

The 16-bit  $\Sigma\Delta$  ADC is capable of programmable continuous conversion rates of 30Hz or 60Hz and gains of 1/3, 1, and 2V/V to suit applications with different power and dynamic range constraints. The force/sense DACs provide 10-bit linearity for precise sensor applications.

**Table 1. MAX1407/MAX1408/MAX1409/MAX1414 Feature Sets**

PART	ADC AUXILIARY ANALOG INPUTS	FORCE/SENSE DAC	THREE-STATE DIGITAL OUTPUT	COMPARATOR THRESHOLD (mV)	RTC	ADC DATA READY (DRDY)	EXTERNAL POWER-SUPPLY SHUTDOWN CONTROL	ADC DIFFERENTIAL INPUT MUX
MAX1407	4	2	Yes	0	Yes	Yes	Yes	8
MAX1414	4	2	Yes	50	Yes	Yes	Yes	8
MAX1408	8	0	Yes	0	Yes	Yes	Yes	8
MAX1409	1	1	No	0	Yes	No	No	4

# Low-Power, 16-Bit Multichannel DAS with Internal Reference, 10-Bit DACs, and RTC

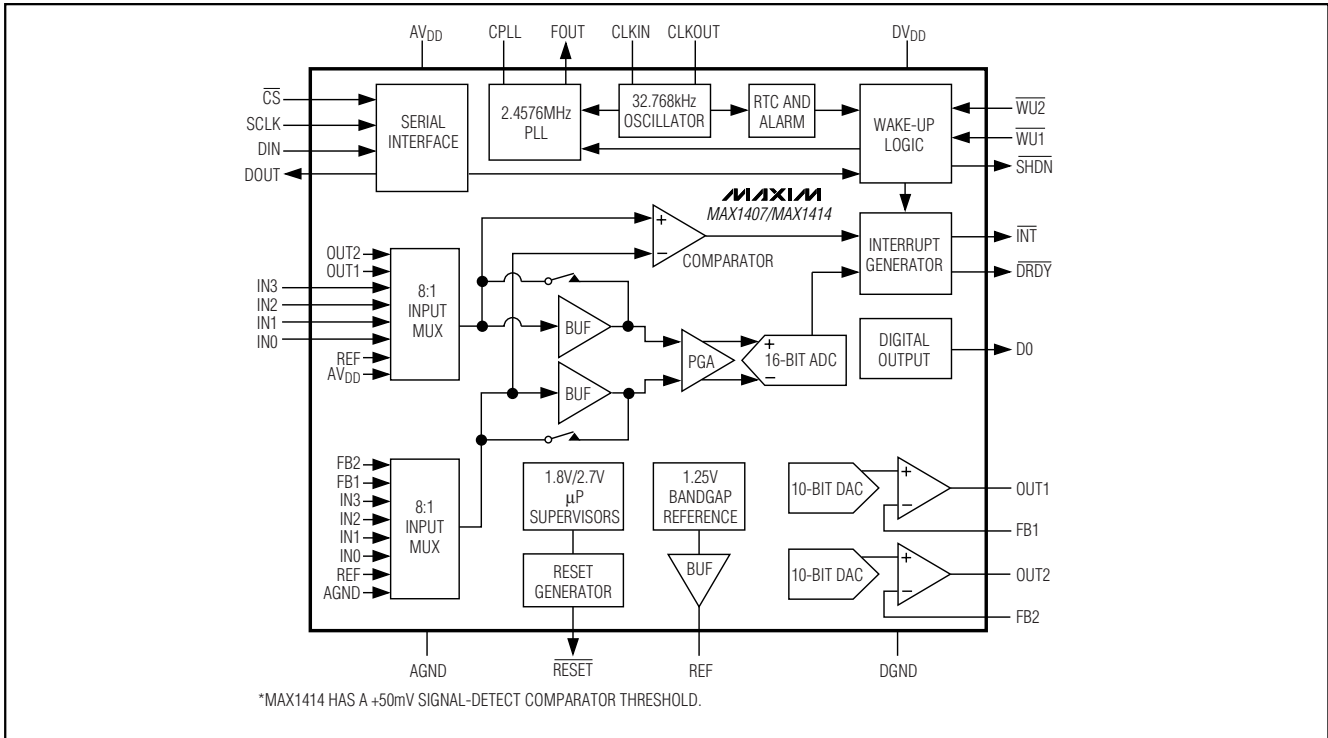

Figure 1. MAX1407/MAX1414 Functional Diagram

With the use of two external resistors, the DAC output can go from 0.05V to  $AV_{DD} - 0.2V$ . The ADCs and DACs both utilize a precise low-drift 1.25V internal bandgap reference for conversions and setting of the full-scale range. For applications that require increased accuracy, power-down the internal reference and connect an external reference at REF. The RTC is leap year compensated until 9999 and provides an alarm function that can be used to wake-up the system or cause an interrupt at a predefined time. The power-supply voltage monitors detect when  $AV_{DD}$  falls below a trip threshold voltage at either +1.8V or +2.7V causing the reset to be asserted. The 4-wire serial interface is used to communicate directly between SPI, QSPI, and MICROWIRE devices for system configuration and readback functions.

### Analog Input Protection

Internal protection diodes clamp the analog input to  $AV_{DD}$  and AGND, which allow the channel input pins to swing from AGND - 0.3V to  $AV_{DD} + 0.3V$  without damage. However, for accurate conversions near full scale, the inputs must not exceed  $AV_{DD}$  by more than 50mV or be lower than AGND by 50mV.

### Analog Mux

The MAX1407/MAX1408/MAX1414 include a dual 8 to 1 multiplexer for the positive and negative inputs of the ADC. The MAX1409 has a dual 4 to 1 multiplexer at the inputs of the ADC. Figures 1, 2, and 3 illustrate which signals are present at the inputs of each multiplexer for the MAX1407/MAX1408/MAX1409/MAX1414. The MUXP and MUXN bits of the MUX register choose which inputs will be seen at the input to the ADC (Tables 4 and 5) and the signal-detect comparator. See the MUX Register description under the *On-Chip Registers* section for multiplexer functionality.

### Input Buffers

The MAX1407/MAX1408/MAX1409/MAX1414 provide input buffers to isolate the analog inputs from the capacitive load presented by the ADC modulator (Figure 5 and 6). The buffers are chopper stabilized to reduce the effect of their DC offsets and low-frequency noise. Since the buffers can represent more than 25% of the total analog power dissipation (typically 220 $\mu$ A), they may be shut down in applications where minimum power dissipation is required and the capacitive input load is not a concern (see *ADC and Power1 Registers*). Disable the buffers in applications where the inputs must operate close to AGND or above +1.4V. The buffers are individually enabled or disabled.

# Low-Power, 16-Bit Multichannel DAS with Internal Reference, 10-Bit DACs, and RTC

MAX1407/MAX1408/MAX1409/MAX1414

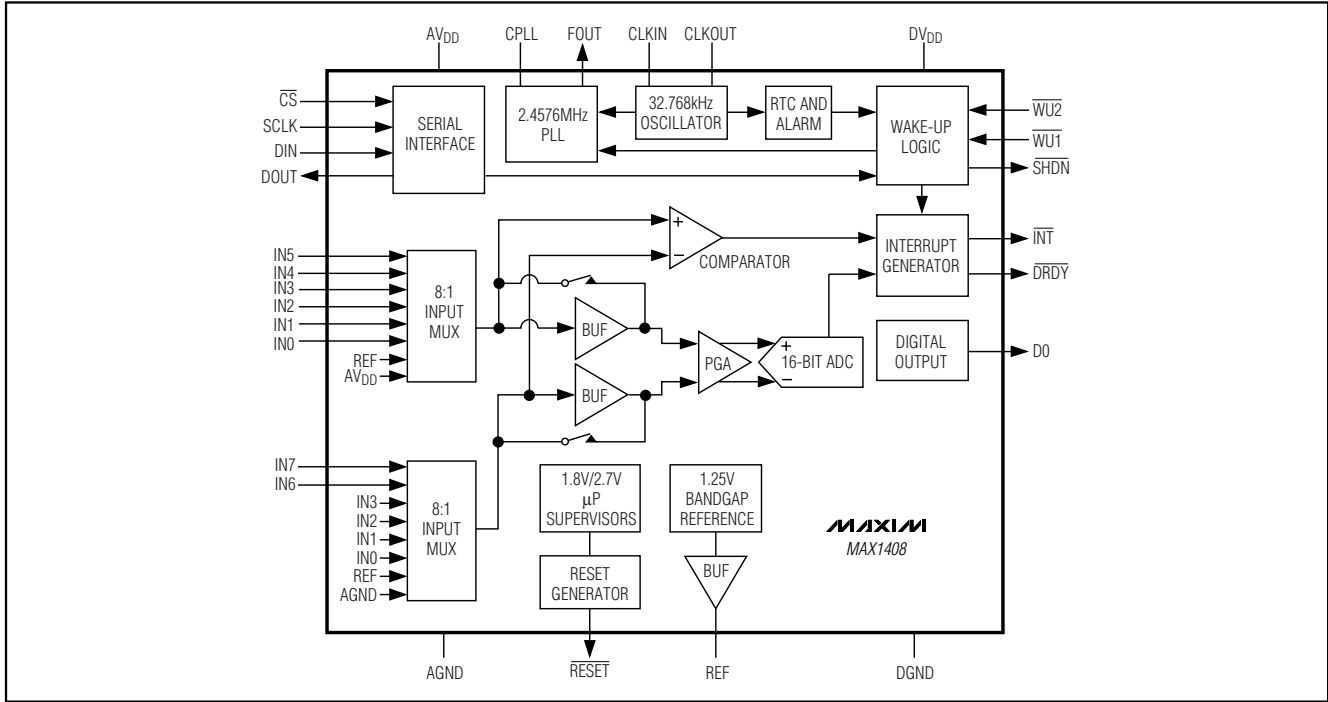

Figure 2. MAX1408 Functional Diagram

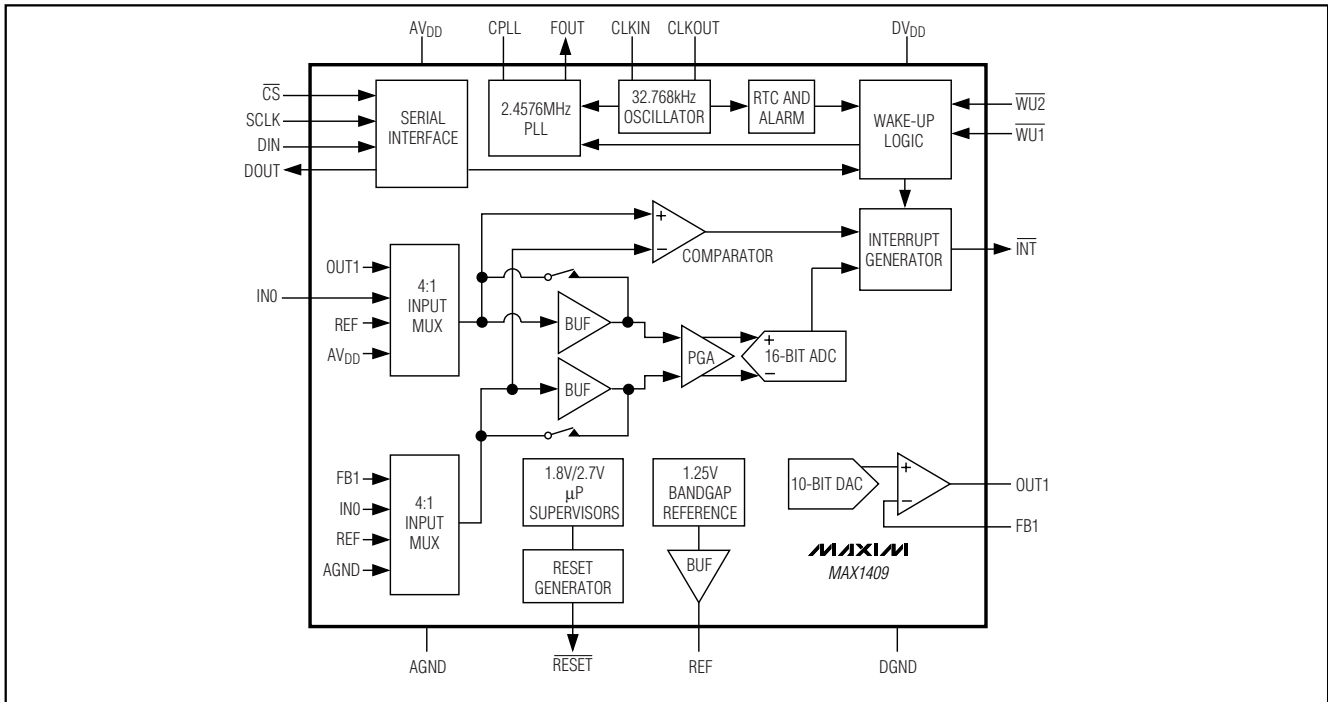

Figure 3. MAX1409 Functional Diagram

# Low-Power, 16-Bit Multichannel DAS with Internal Reference, 10-Bit DACs, and RTC

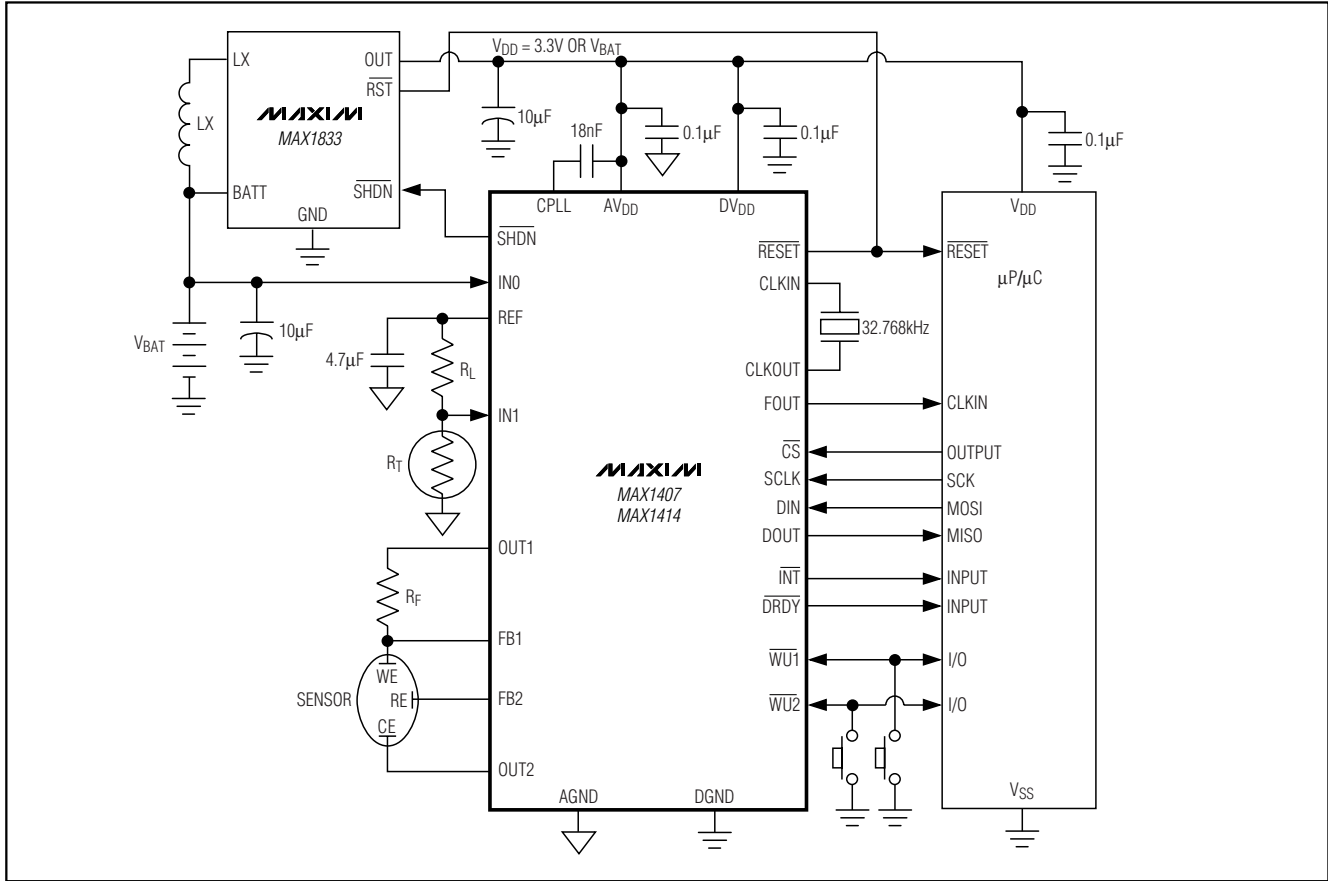

Figure 4. MAX1407/MAX1414 Typical Application Circuit

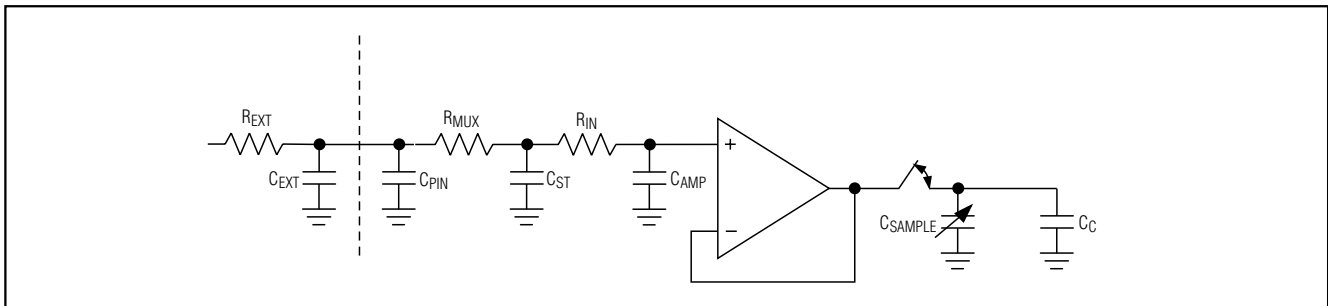

Figure 5. Analog Input—Buffered Mode

### Buffered Mode

When used in buffered mode, the buffers isolate the inputs from the sampling capacitors. The sampling-related gain error is dramatically reduced since only a

small dynamic load is present from the chopper. The multiplexer exhibits an input leakage current of 0.5nA (typ). With high-source resistances, this leakage current may result in a large DC offset error.

# Low-Power, 16-Bit Multichannel DAS with Internal Reference, 10-Bit DACs, and RTC

MAX1407/MAX1408/MAX1409/MAX1414

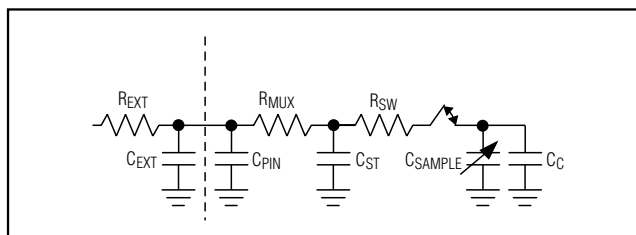

Figure 6. Analog Input—Unbuffered Mode

## Unbuffered Mode

When used in unbuffered mode, the switched capacitor sampling front end of the modulator presents a dynamic load to the driving circuitry. The size of the internal sampling capacitor and the input sampling frequency (Figure 6) determines the dynamic load (see *Dynamic Input Impedance* section). As the gain increases, the input sampling capacitance also increases. Since the MAX1407/MAX1408/MAX1409/MAX1414 sample at a constant rate for all gain settings, the dynamic load presented by the inputs varies with the gain setting.

## PGA Gain

An integrated programmable-gain amplifier (PGA) provides three user-selectable gains: +1/3V/V, +1V/V, and +2V/V to maximize the dynamic range of the ADC. Bits GAIN1 and GAIN0 set the desired gain (see *ADC Register*). The gain of +1/3V/V allows the direct measurement of the supply voltage through an internal multiplexer input or through an auxiliary input.

## ADC Modulator

The MAX1407/MAX1408/MAX1409/MAX1414 perform analog-to-digital conversions using a single-bit, second-order, switched-capacitor delta-sigma modulator. The delta-sigma modulation converts the input signal into a digital pulse train whose average duty cycle represents the digitized signal information. The pulse train is then processed by a digital decimation filter.

The modulator provides 2nd-order frequency shaping of the quantization noise resulting from the single bit quantizer. The modulator is fully differential for maximum signal-to-noise ratio and minimum susceptibility to power-supply noise. The modulator operates at one of two different sampling rates resulting in an output data rate of either 30Hz or 60Hz (see *ADC Register*).

## ADC Offset Calibration

The MAX1407/MAX1408/MAX1409/MAX1414 are capable of performing digital offset correction to eliminate changes due to power-supply voltage or system temperature. At the end of a calibration cycle, a 16-bit calibration value is stored in the Offset register in two's complement format. After completing a conversion, the MAX1407/MAX1408/MAX1409/MAX1414 subtract the calibration value from the ADC conversion result and write the offset compensated data to the Data register (see *Offset Register* section). Either a positive or negative offset can be calibrated. During offset calibration, DRDY will go high. DRDY goes low after calibration is complete. The offset register can be programmed to skew the ADC offset with a maximum range from  $-2^{15}$  to  $(+2^{15} - 1)$ LSBs, e.g., if the programmed 2's complement value is +2LSB (-2LSB), this translates to a -2LSB (+2LSB) shift in bipolar mode or a -4LSB (+4LSB) shift in unipolar mode. To maintain optimum performance, recalibrate the ADC if the temperature changes by more than 20°C. Offset calibration should also be performed after any changes in PGA gain, bipolar/unipolar input range, buffered/unbuffered mode, or conversion speed. During calibration, the two multiplexers will be disabled and the inputs to the ADC will internally be shorted to a common-mode voltage.

## ADC Digital Filter

The on-chip digital filter processes the 1-bit data stream from the modulator using a SINC<sup>3</sup> filter function. The SINC<sup>3</sup> filters settle in three data word periods. The settling time is 3/60Hz or 50ms (for RATE bit in ADC register set to 1) and 3/30Hz or 100ms (for RATE bit set to "0").

## ADC Digital Filter Characteristics

The transfer function for a SINC<sup>3</sup> filter function is that of three cascaded SINC<sup>1</sup> filters. This can be described in the Z-domain by:

$$H(z) = \left[ \frac{1}{N} \frac{(1 - z^{-N})^3}{(1 - z^{-1})} \right]$$

and in the frequency domain by:

$$H(f) = \left[ \frac{1}{N} \frac{\sin\left(N\pi \frac{f}{f_M}\right)^3}{\sin\left(\pi \frac{f}{f_M}\right)} \right]^3$$

where N, the decimation factor, is the ratio of the modulator frequency  $f_M$  to the output frequency  $f_N$ .

# Low-Power, 16-Bit Multichannel DAS with Internal Reference, 10-Bit DACs, and RTC

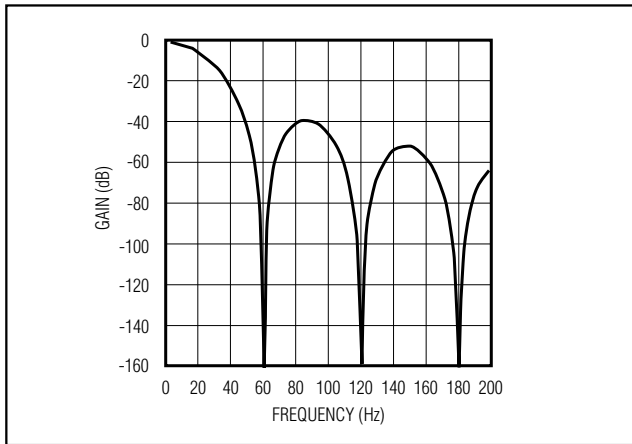

Figure 7. Frequency Response of the SINC<sup>3</sup> Filter (Notch at 60Hz)

Figure 7 shows the filter frequency response. The SINC<sup>3</sup> characteristic cutoff frequency is 0.262 times the first notch frequency. This results in a cutoff frequency of 15.72Hz for a first filter notch frequency of 60Hz (output data rate of 60Hz). The response shown in Figure 7 is repeated at either side of the digital filter's sample frequency ( $f_M$ ) ( $f_M = 15.36\text{kHz}$  for 30Hz and  $f_M = 30.72\text{kHz}$  for 60Hz) and at either side of the related harmonics ( $2f_M, 3f_M, \dots$ ).

The output data rate for the digital filter corresponds with the positioning of the first notch of the filter's frequency response. Therefore, for the plot of Figure 7 where the first notch of the filter is at 60Hz, the output data rate is 60Hz. The notches of this  $(\text{sinc}/x)^3$  filter are repeated at multiples of the first notch frequency. The SINC<sup>3</sup> filter provides an attenuation of better than 100dB at these notches.

For step changes at the input, enough settling time must be allowed before valid data can be read. The settling time depends upon the output data rate chosen for the filter. The settling time of the SINC<sup>3</sup> filter to a full-scale step input can be up to four times the output data period, or three times if the step change is synchronized with FSYNC.

### Force/Sense DAC (MAX1407/MAX1409/MAX1414)

The MAX1407/MAX1414 incorporate two 10-bit force/sense DACs while the MAX1409 has one. The DACs use a precise 1.25V internal bandgap reference for setting the full-scale range. Program the DAC1 and DAC2 registers through the serial interface to set the output voltages of the DACs seen at OUT1 and OUT2.

Shorting FB1(2) and OUT1(2) configures the DAC in a unity-gain setting. Connecting resistors in a voltage-divider configuration between OUT1(2), FB1(2), and GND sets a different closed-loop gain for the output amplifier (see the *Applications Information* section).

The DAC output amplifier typically settles to  $\pm 1/2\text{LSB}$  from a full-scale transition within  $65\mu\text{s}$ , when it is connected in unity gain and loaded with  $12\text{k}\Omega$  in parallel with  $200\text{pF}$ . Loads less than  $2\text{k}\Omega$  may degrade performance. See the *Typical Operating Characteristics* section for the source-and-sink capability of the DAC output.

The MAX1407/MAX1408/MAX1409/MAX1414 feature a software-programmable shutdown mode for the DACs that reduce the total power consumption when they are not used. The two DACs can be powered-down independently or simultaneously by clearing the DA1E and DA2E bits (see *Power1 Register*). DAC outputs OUT1 and OUT2 go high impedance when powered down. The DACs are automatically powered up and ready for a conversion when Idle or Run mode is entered.

### Voltage Monitors

The MAX1407/MAX1408/MAX1409/MAX1414 include two on-board voltage monitors. When  $\text{AV}_{\text{DD}}$  is below the  $\overline{\text{RESET}}$  trip threshold,  $\overline{\text{RESET}}$  goes low and the RST bit of the Status register is set to "1". When  $\text{AV}_{\text{DD}}$  is below the Low  $\text{V}_{\text{DD}}$  trip threshold, the LVD bit of the Status register is set to 1.

### $\overline{\text{RESET}}$ Voltage Monitor

The  $\overline{\text{RESET}}$  voltage monitor is powered up at all times (provided that  $\text{VM} = 0$  and  $\text{LVDE} = 1$  or  $\text{VM} = 1$  and  $\text{LSDE} = 1$ ). A threshold voltage of either +1.8V or +2.7V may be selected for the  $\overline{\text{RESET}}$  voltage monitor (see *Power2 Register*). At initial power-up, the  $\overline{\text{RESET}}$  trip threshold is set to 2.7V. If the  $\overline{\text{RESET}}$  voltage monitor is tripped, the RST bit of the status register is set to "1" and  $\overline{\text{RESET}}$  goes low.  $\overline{\text{RESET}}$  is held low for 1.54 seconds (typ) after  $\text{AV}_{\text{DD}}$  rises above the  $\overline{\text{RESET}}$  voltage monitor threshold. If  $\text{AV}_{\text{DD}}$  is no longer below the  $\overline{\text{RESET}}$  threshold, reading the Status register will clear RST.

### Low $\text{V}_{\text{DD}}$ Voltage Monitor

When the device is operating in Run, Idle, or Standby mode (see *Power Modes*) and  $\text{AV}_{\text{DD}}$  goes below +2.7V, the low  $\text{V}_{\text{DD}}$  monitor trips, indicating that the supply voltage is below the safe minimum for proper operation. When tripped, the Low  $\text{V}_{\text{DD}}$  Voltage Monitor sets the LVD bit of the Status register to 1. If  $\text{AV}_{\text{DD}}$  is no longer below +2.7V, reading the Status register will clear LVD. The low  $\text{V}_{\text{DD}}$  monitor is powered down in Sleep mode. When it is powered down, the LVD bit stays unchanged. The LVD is cleared if it is read in Sleep mode.

# Low-Power, 16-Bit Multichannel DAS with Internal Reference, 10-Bit DACs, and RTC

## Internal/External Reference

The MAX1407/MAX1408/MAX1409/MAX1414 have an internal low-drift +1.25V reference used for both ADC and DAC conversion. The buffered reference output can be used as a reference source for other devices in the system. The internal reference requires a 4.7 $\mu$ F low-ESR ceramic capacitor or tantalum capacitor connected between REF and AGND. For applications that require increased accuracy, power-down the internal reference by writing a 0 to the REFE bit of the Power1 register and connect an external reference source to REF. The valid external reference voltage range is 1.25V  $\pm$ 100mV.

## Crystal Oscillator

The on-chip oscillator requires an external crystal (or resonator) connected between CLKIN and CLKOUT with an operating frequency of 32.768kHz. This oscillator is used for the RTC, alarm, signal-detect comparator, and PLL. The oscillator is operational down to 1.8V. In any crystal-based oscillator circuit, the oscillator frequency is based on the characteristics of the crystal. It is important to select a crystal that meets the design requirements, especially the capacitive load ( $C_L$ ) that must be placed across the crystal pins in order for the crystal to oscillate at its specified frequency.  $C_L$  is the capacitance that the crystal needs to “see” from the oscillator circuit; it is not the capacitance of the crystal itself. The MAX1407/MAX1408/MAX1409/MAX1414 have 6pF of capacitance across the CLKIN and CLKOUT pins. Choose a crystal with a 32.768kHz oscillation frequency and a 6pF capacitive load such as the C-002RX32-E from Epson Crystal. Using a crystal with a  $C_L$  that is larger than the load capacitance of the oscillator circuit will cause the oscillator to run faster than the specified nominal frequency of the crystal. Conversely, using a crystal with a  $C_L$  that is smaller than the load capacitance of the oscillator circuit will cause the oscillator to run slower than the specified nominal frequency of the crystal.

## Phase-Locked Loop (PLL) and FOUT

An on-board phase-locked loop generates a 2.4576MHz clock at FOUT from the 32.768kHz crystal oscillator. FOUT can be used to clock a  $\mu$ P or other digital circuitry. Connect an 18nF ceramic capacitor from CPLL to AVDD to create the 2.4576MHz clock signal at FOUT. To power down the PLL, clear PLLE in the Power2 register (see *Power2 Register*) or write to the Sleep register. FOUT will be active for 1.95ms ( $t_{DFOF}$ ) after receiving either power-down command and then go low. This provides extra clock signals to the  $\mu$ P to complete a shutdown sequence. The PLL is active in all

modes except the sleep mode (see *Power Modes*). To reactivate the PLL, the following conditions must be met: AVDD is greater than the low VDD voltage monitor threshold, RESET is deasserted, and the PLLE bit is equal to “1”. FOUT is enabled 31.25ms ( $t_{DFON}$ ) after the PLL is activated. At initial power-up, the PLL is enabled. If RESET is asserted while the PLL is running, the PLL does not shut down.

## Real-Time Clock (RTC)

The integrated RTC provides the current second, minute, hour, date, month, day, year, century, and millennium information. An internally generated reference clock of 1.024kHz (derived from the 32.768kHz crystal) drives the RTC. The RTC operates in either 24-hour or 12-hour format with an AM/PM indicator (see *RTC\_Hour Register*). An internal calendar compensates for months with less than 31 days and includes leap year correction through the year 9999. The RTC operates from a supply voltage of +1.8V to +3.6V and consumes less than 1 $\mu$ A current.

## Time of Day Alarm

The MAX1407/MAX1408/MAX1409/MAX1414 offer a time of day alarm which generates an interrupt when the RTC reaches a preset combination of seconds, minutes, hours, and day (see *Alarm Registers*). In addition to setting a “single-shot” alarm, the Time of Day Alarm can also be programmed to generate an alarm every second, minute, hour, day, or week. “Don’t care” states can be inserted into one or more fields if it is desired for them to be ignored for the alarm condition. The Time of Day Alarm wakes up the device into Standby mode if it is in Sleep mode. The Time of Day Alarm operates from a supply voltage of +1.8V to +3.6V.

## Interrupt ( $\overline{INT}$ )

$\overline{INT}$  indicates one of three conditions. After receiving a valid interrupt ( $\overline{INT}$  goes low), read the Status register and the AI\_Status register (if the alarm is enabled) to identify the source of the interrupt. The three sources of interrupts are from the CLK, SDC, and ALIRQ bits.

## PLL Ready

On power-up,  $\overline{INT}$  is high. 7.82ms ( $t_{DFI}$ ) after the PLL output appears on FOUT,  $\overline{INT}$  goes low (see Figure 15). The CLK bit of the Status register is set to “1” after FOUT is enabled. Reading the Status register clears the CLK bit.  $\overline{INT}$  remains low until the device detects a start bit through the serial interface from the  $\mu$ P. The purpose of this interrupt is to inform the  $\mu$ P that the FOUT clock signal is present.

# Low-Power, 16-Bit Multichannel DAS with Internal Reference, 10-Bit DACs, and RTC

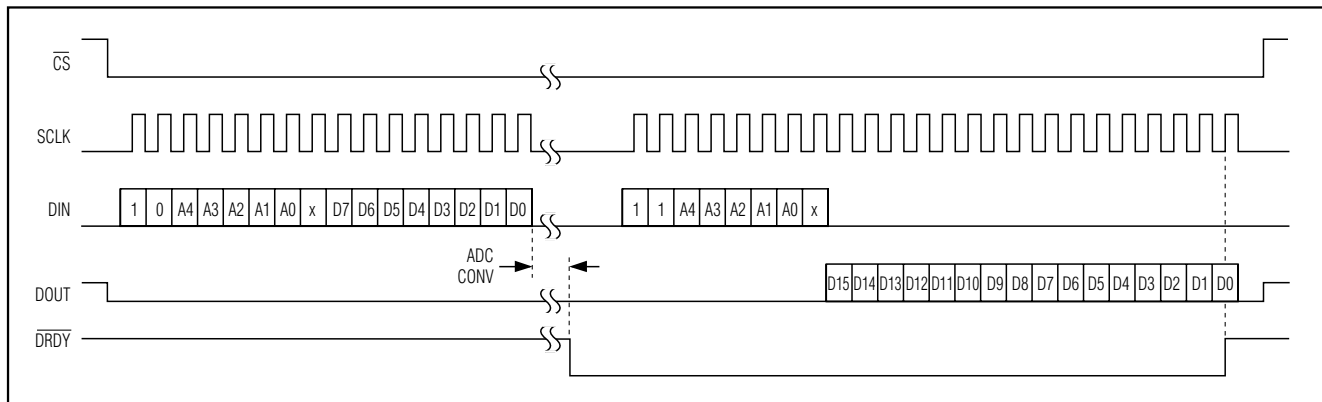

Figure 8. ADC Conversion Timing Diagram

### Signal Detect

The  $\overline{\text{INT}}$  pin will also go low and stay low when the differential voltage on the selected analog inputs exceeds the signal-detect comparator trip threshold (0mV for the MAX1407/MAX1408/MAX1409 and 50mV for the MAX1414). This will latch the SDC bit of the Status register to one. Additional signal detect interrupts cannot be generated unless the SDC bit is cleared. To clear the SDC bit, the Status register must be read and the input must be below the signal-detect threshold. Powering down the signal detect-comparator without reading the Status register will also clear the SDC bit. Similar to the power-up case,  $\overline{\text{INT}}$  goes high when the device detects a start bit through the serial interface from the  $\mu\text{P}$ .

### Time of Day Alarm

If the device is in Sleep mode, the alarm will wake up the device and set the ALIRQ bit.  $\overline{\text{INT}}$  is asserted when the PLL is turned on. If an alarm occurs while the device is awake ( $\text{BIASE} = 1$ ), the ALIRQ bit will be set and  $\overline{\text{INT}}$  will go low.  $\overline{\text{INT}}$  remains low until the device detects a start bit through the serial interface from the  $\mu\text{P}$ . ALIRQ is reset to 0 when any alarm register is read or written to.

### Shutdown ( $\overline{\text{SHDN}}$ )

$\overline{\text{SHDN}}$  is an active-low output that can be used to control an external power supply. Powering up the PLL ( $\text{PLLE} = 1$ ) or writing a "1" to the SHDE bit of the Power2 register causes  $\overline{\text{SHDN}}$  to go high.  $\overline{\text{SHDN}}$  goes low when the SHDE bit is set to 0 only if the PLL is powered down ( $\text{PLLE} = 0$ ). The  $\overline{\text{SHDN}}$  output stays high for 2.93ms ( $t_{\text{DPD}}$ ) after receiving a power-down command, allowing the external power supply to stay alive so that the  $\mu\text{P}$  can properly complete a shutdown sequence.

$\overline{\text{SHDN}}$  is not available on the MAX1409. **Note:** Entering Sleep mode automatically sets  $\overline{\text{PLLE}}$  and SHDE to 0. Any wake-up event will cause  $\overline{\text{SHDN}}$  to go high. (See *Wake-Up* section.)

### Data Ready ( $\overline{\text{DRDY}}$ )

This pin will go low and stay low upon completion of an ADC conversion or end of an ADC calibration. This signals the  $\mu\text{P}$  that a valid conversion or calibration result has been written to the DATA or the OFFSET register. The  $\overline{\text{DRDY}}$  pin goes high either when the  $\mu\text{P}$  has finished reading the conversion/calibration result on the last rising edge of SCLK (see Figure 8), or when the next conversion result is about to be written to the DATA register. When no read operation is performed,  $\overline{\text{DRDY}}$  pulses at 60Hz with a pulse high time of 162.76 $\mu\text{s}$  (or 30Hz with a pulse high time of 325.52 $\mu\text{s}$ )  $\overline{\text{DRDY}}$  is not available on the MAX1409. To see when the ADC has completed a normal conversion or a calibration conversion for the MAX1409, check the status of the ADD bit in the Status register.

### Serial Digital Interface

The SPI/QSPI/MICROWIRE-serial interface consists of chip select ( $\overline{\text{CS}}$ ), serial clock (SCLK), data in (DIN), and data out (DOUT) (See Figure 9). The serial interface provides access to 29 on-chip registers, allowing control to all the power modes and functional blocks, including the ADCs, DACs, and RTC. Table 2 lists the address and read/write accessibility of all the registers.

A logic high on  $\overline{\text{CS}}$  three-states DOUT and causes the MAX1407/MAX1408/MAX1409/MAX1414 to ignore any signals on SCLK and DIN. To clock data into or out of the internal shift register, drive  $\overline{\text{CS}}$  low. SCLK synchronizes the data transfer. The rising edge of SCLK clocks DIN into the shift register, and the falling edge of SCLK

# Low-Power, 16-Bit Multichannel DAS with Internal Reference, 10-Bit DACs, and RTC

MAX1407/MAX1408/MAX1409/MAX1414

clocks DOUT out of the shift register. DIN and DOUT are transferred as MSB first (data is left justified). Figure 10 shows detailed serial interface timing.

All communication with the MAX1407/MAX1408/MAX1409/MAX1414 begins with a command byte on DIN, where the first logic 1 on DIN will be recognized as the START bit (MSB) for the command byte (Table 3). The following seven clock cycles load the command into a shift register. These seven bits specify which of the registers will be accessed, whether a read or write operation will take place, and the length of the subsequent data (0-bit, 8-bit, 16-bit, or burst mode). Idle DIN low

between writes to the MAX1407/MAX1408/MAX1409/MAX1414. Figures 11–14 show the read and write timing for 8- and 16-bit data. Data is updated on the last rising edge of the SCLK in the command word.  $\overline{CS}$  should not go high between data transfers. If  $\overline{CS}$  is toggled before the end of a write or read operation, the device can enter an incorrect mode. Clock in 72 zeros to clear this state and re-arm the serial interface.

After loading the command byte into the shift register, additional clocks shift out data on DOUT for a read and shift in data on DIN for a write operation.

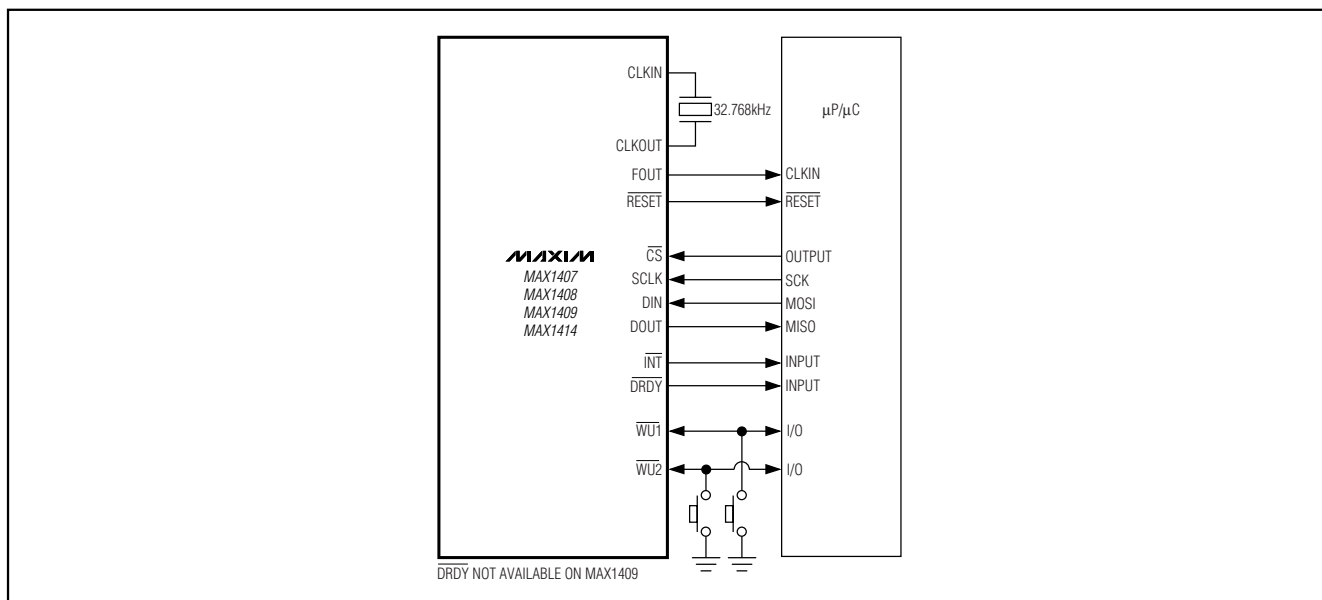

Figure 9. SPI/QSPI Interface Connections

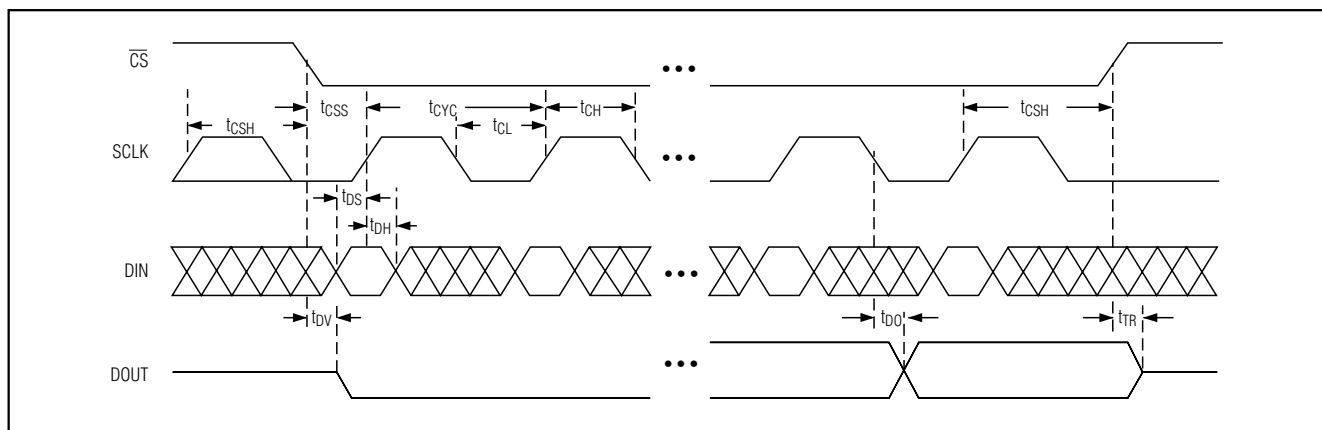

Figure 10. Detailed Serial Interface Timing

# Low-Power, 16-Bit Multichannel DAS with Internal Reference, 10-Bit DACs, and RTC

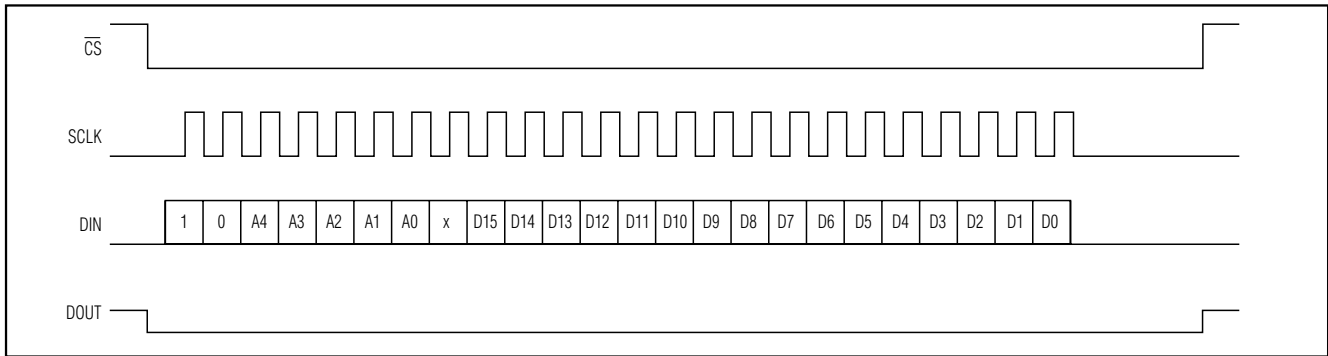

Figure 11. Serial Interface 16-Bit Write Timing Diagram

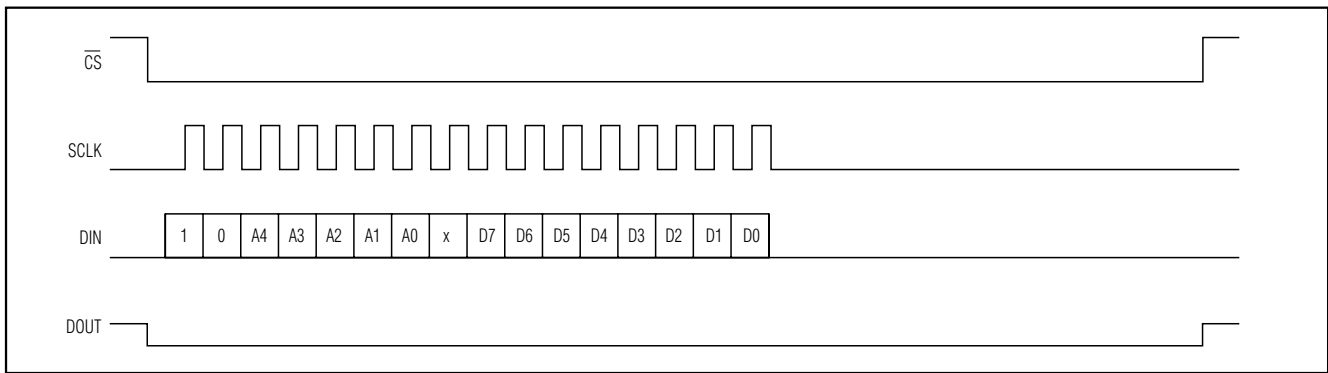

Figure 12. Serial Interface 8-Bit Write Timing Diagram

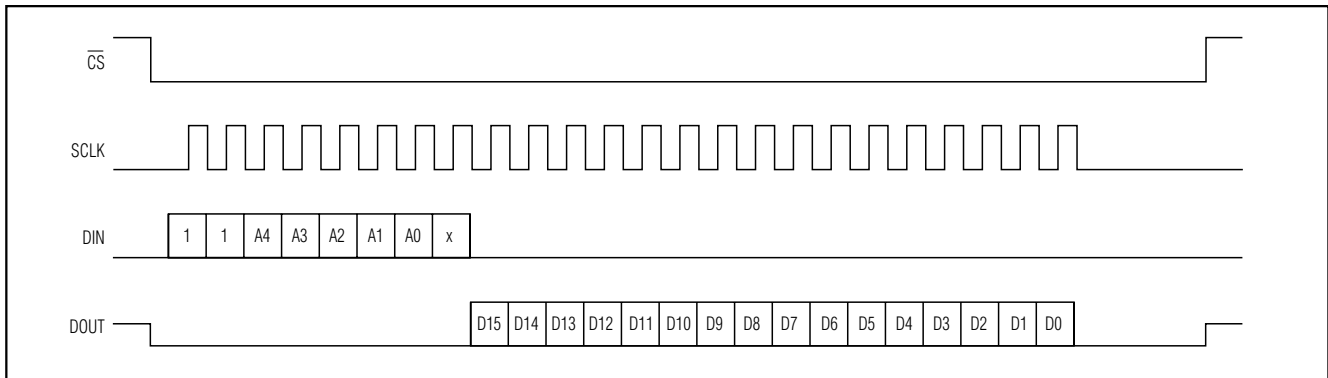

Figure 13. Serial Interface 16-Bit Read Timing Diagram

$\overline{CS}$  allows the SCLK, DIN, and DOUT signals to be shared among several devices. When short on processor I/O pins, connect CS to DGND, and operate the serial digital interface in CPOL = 1, CPHA = 1 or CPOL = 0, CPHA = 0 modes using SCLK, DIN, and DOUT.

# Low-Power, 16-Bit Multichannel DAS with Internal Reference, 10-Bit DACs, and RTC

MAX1407/MAX1408/MAX1409/MAX1414

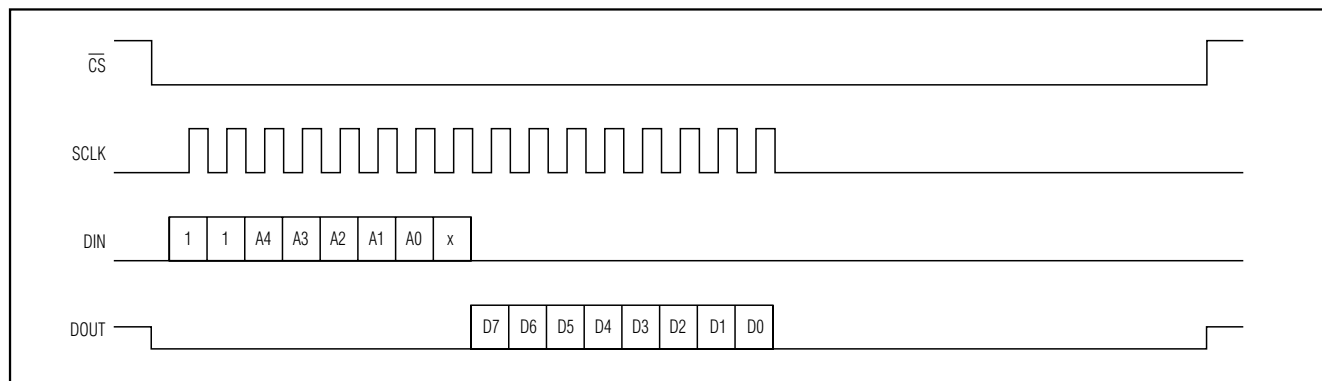

Figure 14. Serial Interface 8-Bit Read Timing Diagram

**Table 2. Register Summary and Addressing**

TARGET REGISTER	R/W ACCESS	ADD4:ADD0
ADC Register	R/W	00000
MUX Register	R/W	00001
Data Register	R	00010
Offset Register	R/W	00011
DAC1 Register	R/W	00100
DAC2 Register	R/W	00101
Status Register	R	00110
AI_Burst Register	R/W	01000
AI_Sec Register	R/W	01001
AI_Min Register	R/W	01010
AI_Hour Register	R/W	01011
AI_Day Register	R/W	01100
AI_Status Register	R	01101
Alarm/Clock_Ctrl Register	R/W	01110
RTC_Burst Register	R/W	01111

TARGET REGISTER	R/W ACCESS	ADD4:ADD0
RTC_Sec Register	R/W	10000
RTC_Min Register	R/W	10001
RTC_Hour Register	R/W	10010
RTC_Date Register	R/W	10011
RTC_Month Register	R/W	10100
RTC_Day Register	R/W	10101
RTC_Year Register	R/W	10110
RTC_Century Register	R/W	10111
Power1 Register	R/W	11000
Power2 Register	R/W	11001
Sleep Register	W	11010
Standby Register	W	11011
Idle Register	W	11100
Run Register	W	11101

**Table 3. Command Byte Format**

COMMAND	BIT 7 (MSB)	BIT 6	BIT 5	BIT 4	BIT 3	BIT 2	BIT 1	BIT 0 (LSB)
Write	1	0	ADD4:ADD0 (see Table 2)				X	
Read	1	1	ADD4:ADD0 (see Table 2)				X	

# Low-Power, 16-Bit Multichannel DAS with Internal Reference, 10-Bit DACs, and RTC

## On-Chip Registers

### ADC REGISTER (00000)

FIRST BIT (MSB)						(LSB)		
NAME	MODE	RATE	GAIN1	GAIN0	BUFP	BUFN	BIP	STA1
DEFAULTS	0	0	0	0	0	0	0	0

**MODE:** Conversion Mode bit. A logic zero selects a normal ADC conversion, while a logic 1 selects an offset calibration conversion. After completing a calibration conversion, MODE automatically resets to zero.

**RATE:** Conversion Rate bit. A logic zero selects a 30Hz conversion rate while a logic 1 selects a 60Hz conversion rate.

**GAIN1, GAIN0:** Gain bits. The Gain bits select the PGA gain. For an ADC gain of +1/3, +1, and 2V/V, [GAIN1 GAIN0] are 00, 01, and 10, respectively.

**BUFP:** Positive Buffer bit. When this bit is 0, the positive input buffer is bypassed and powered down. When this bit is 1 and the BUFE bit in the Power1 register is 1, the positive input buffer drives the ADC input sampling capacitors.

**BUFN:** Negative Buffer bit. When this bit is 0, the negative input buffer is bypassed and powered-down. When this bit is 1 and the BUFE bit in the Power1 register is 1, the negative input buffer drives the ADC input sampling capacitors.

**BIP:** Unipolar/Bipolar bit. A logic zero selects unipolar mode while a logic 1 selects bipolar mode.

**STA1:** Start bit. Setting STA1 to a logic 1 resets the registers inside the ADC filter, updates the ADC configuration according to the ADC register, and initiates an analog-to-digital conversion or offset calibration. The initial conversion requires three cycles for valid output data, and each subsequent conversion cycle will output valid data. After completing the initial conversion, STA1 automatically resets to 0; however, the ADC will continue to do conversions until it is powered down.

Writing to the ADC register with STA1 set to 0 updates the ADC register without changing the ADC configuration and allows the ADC to continue conversions uninterrupted. This allows the ADC and MUX configuration to be updated simultaneously. See STA2 bit of the MUX register.

### MUX REGISTER (00001)

FIRST BIT (MSB)						(LSB)		
NAME	MUXP2	MUXP1	MUXP0	MUXN2	MUXN1	MUXN0	DBIT	STA2
DEFAULTS	0	0	0	0	0	0	0	0

**MUXP2, MUXP1, MUXP0:** Positive Multiplexer bits. MUXP[2:0] direct one-of-eight positive inputs to the positive input of the ADC. Table 4 relates the MUXP bits to the positive multiplexer inputs.

**MUXN2, MUXN1, MUXN0:** Negative Multiplexer bits. MUXN[2:0] direct one-of-eight (one-of-four for the MAX1409) negative inputs to the negative input of the ADC. Table 5 relates the MUXN bits to the negative multiplexer inputs.

**DBIT:** Digital Output bit. This bit controls the output state of D0. When the output buffer is enabled, D0 is low if Dbit is equal to 0, and high if Dbit is equal to 1. D0 is enabled by the D0E bit of the Power2 register.

**STA2:** Start bit. Setting STA2 to a logic 1 updates the mux selection, resets the registers inside the ADC filter, updates the ADC configuration according to the ADC register, and initiates an analog-to-digital conversion. The initial conversion requires three cycles for valid output data, and each subsequent conversion cycle will output valid data. STA2 automatically resets to 0 after the initial conversion completes. The ADC will continue to do conversions until it is powered down. Writing to the MUX register with the STA2 bit set to 0, updates the MUX register and selection, but leaves the ADC configuration unchanged. The MUX input can be switched with the ADC continuously converting without the digital filter resetting.

# Low-Power, 16-Bit Multichannel DAS with Internal Reference, 10-Bit DACs, and RTC

MAX1407/MAX1408/MAX1409/MAX1414

**Table 4. Positive Mux Decoding**

POSITIVE MUX INPUT			MUXP2	MUXP1	MUXP0
MAX1407/MAX1414	MAX1408	MAX1409			
AV <sub>DD</sub>	AV <sub>DD</sub>	AV <sub>DD</sub>	0	0	0
REF	REF	REF	0	0	1
OUT1	IN4	OUT1	0	1	0
IN0	IN0	IN0	0	1	1
IN1	IN1	—	1	0	0
IN2	IN2	—	1	0	1
IN3	IN3	—	1	1	0
OUT2	IN5	—	1	1	1

**Table 5. Negative Mux Decoding**

NEGATIVE MUX INPUT			MUXN2	MUXN1	MUXN0
MAX1407/MAX1414	MAX1408	MAX1409			
AGND	AGND	AGND	0	0	0
REF	REF	REF	0	0	1
FB1	IN6	FB1	0	1	0
IN0	IN0	IN0	0	1	1
IN1	IN1	—	1	0	0
IN2	IN2	—	1	0	1
IN3	IN3	—	1	1	0
FB2	IN7	—	1	1	1

**DATA REGISTER—Read-Only (00010)**

**FIRST BIT (MSB)**

ADC15	ADC14	ADC13	ADC12	ADC11	ADC10	ADC9	ADC8
ADC7	ADC6	ADC5	ADC4	ADC3	ADC2	ADC1	ADC0

**(LSB)**

The Data register contains the 16-bit result from the most recently completed ADC conversion. The data format is binary for unipolar mode and two's complement for bipolar mode. After power-up, the DATA register contains all zeros.

# Low-Power, 16-Bit Multichannel DAS with Internal Reference, 10-Bit DACs, and RTC

## OFFSET REGISTER (00011)

### FIRST BIT (MSB)

OFF15	OFF14	OFF13	OFF12	OFF11	OFF10	OFF9	OFF8
OFF7	OFF6	OFF5	OFF4	OFF3	OFF2	OFF1	OFF0

(LSB)

The Offset register contains the 16-bit result from the most recently completed ADC offset calibration. The data format is two's complement and is subtracted from the filter output before writing to the Data register. After power-up, the Offset register contains all zeros.

Each change in ambient operating condition (power supply and temperature), PGA gain, bipolar/unipolar input range, buffered/unbuffered mode, or conversion speed requires an offset calibration. The offset for a given ADC configuration can be read and stored by the  $\mu$ P to avoid ADC recalibration. When returning to an ADC configuration where the offset was stored, write back the stored offset to the Offset register. The stored offset stays valid as long as the ambient operating condition remains unchanged (within  $\pm 20^{\circ}\text{C}$ ).

### Force Sense DAC Registers (MAX1407/MAX1409/MAX1414 only)

Writing to the DAC1 register updates the output of DAC1. Writing to the DAC2 register updates the output of DAC2. The DAC data is 10-bit long and left justified. Follow the timing diagrams of Figure 11 and Figure 13 to program these registers. Writing a logic 0 to the DA1E or DA2E bit in the POWER2 register disables DAC1 or DAC2, respectively. At power-up, DAC1 and DAC2 are disabled.

## DAC1 REGISTER (00100)

### FIRST BIT (MSB)

DAC1[9]	DAC1[8]	DAC1[7]	DAC1[6]	DAC1[5]	DAC1[4]	DAC1[3]	DAC1[2]
DAC1[1]	DAC1[0]	x	x	x	x	x	x

(LSB)

Writing to the DAC1 register will update the DAC1 output (OUT1). The output voltage in a unity gain configuration is  $V_{\text{REF}} \times N / (2^{10})$ , where N is the integer value of DAC1[9:0]

(0 to 1023), and  $V_{\text{REF}}$  is the reference voltage for the DAC. The DAC1 data is 10-bit long and left justified. After power-up, the DAC1 register contains all zeros.

## DAC2 REGISTER (00101)

### FIRST BIT (MSB)

DAC2[9]	DAC2[8]	DAC2[7]	DAC2[6]	DAC2[5]	DAC2[4]	DAC2[3]	DAC2[2]
DAC2[1]	DAC2[0]	x	x	x	x	x	x

(LSB)

Writing to the DAC2 register will update the DAC2 output (OUT2). The output voltage in a unity-gain configuration is  $V_{\text{REF}} \times N / (2^{10})$ , where N is the integer value of DAC2[9:0]

(0 to 1023), and  $V_{\text{REF}}$  is the reference voltage for the DAC. The DAC2 data is 10-bit long and left justified. After power-up, the DAC2 register contains all zeros.

# Low-Power, 16-Bit Multichannel DAS with Internal Reference, 10-Bit DACs, and RTC

## STATUS REGISTER (00110)

	FIRST BIT (MSB)				LSB)			
NAME	WU2	WU1	RST	LVD	SDC	CLK	ADD	—
DEFAULT	0	0	1	1	0	0	0	0

**WU2:** Wake-Up2 status bit. When  $\overline{WU2}$  is pulled low, WU2 is set to a logic 1. Reading the Status register clears WU2, unless  $\overline{WU2}$  is still low. When  $\overline{WU2}$  is pulled low when the device is awake (not in Sleep mode), WU2 is cleared.

**WU1:** Wake-Up1 status bit. When  $\overline{WU1}$  is pulled low, WU1 is set to a logic 1. Reading the Status register clears WU1, unless  $\overline{WU1}$  is still low. When  $\overline{WU1}$  is pulled low when the device is awake (not in Sleep mode), WU1 is cleared.

**RST:** Reset status bit. When  $\overline{AVDD}$  drops below the  $\overline{RESET}$  Voltage Monitor trip threshold (+1.8V or +2.7V), RST is set to 1. This corresponds to the assertion of the  $\overline{RESET}$  pin. Reading the Status register clears RST, unless  $\overline{AVDD}$  is still below the  $\overline{RESET}$  Voltage Monitor trip threshold. At power-up, RST is at a logic 1 until the Status register is read.

**LVD:** Low  $V_{DD}$  status bit. When  $\overline{AVDD}$  drops below the Low  $V_{DD}$  Voltage Monitor trip threshold (+2.7V), LVD is set to a logic 1. Reading the Status register clears LVD unless  $\overline{AVDD}$  is still below 2.7V. At power-up, LVD is at a logic 1 until the Status register is read. When the Low  $V_{DD}$  Voltage Monitor is powered down (LVDE = 0), the LVD bit stays unchanged.

**SDC:** Signal-Detect Comparator status bit. SDC is set to “1” when the differential polarity voltage across the signal-detect comparator exceeds the signal-detect threshold (0mV for the MAX1407/MAX1408/MAX1409 and 50mV for the MAX1414). This corresponds to the assertion of the  $\overline{INT}$  pin. Reading the Status register clears SDC unless the condition remains true. SDC is also reset to 0 when the signal-detect comparator is powered down (SDCE = 0).

**CLK:** FOUT Clock Enable status bit. CLK is set to “1” after the FOUT clock pin has been enabled in  $t_{DFON}$  milliseconds (see Figure 15). Reading the Status register clears the CLK bit.

**ADD:** ADC Done Status bit. ADD is set to “1” to indicate that the ADC has completed either a normal conversion or a calibration conversion, and the conversion result is available to be read. This corresponds to the assertion of the  $\overline{DRDY}$  pin. Reading either the Data or Offset register clears the ADD bit. Reading the Status register **WILL NOT** clear this bit.

### Alarm Registers

The Al\_Sec, Al\_Min, Al\_Hour, Al\_Day registers are programmed through the serial port to store the preset time data in binary-coded decimal format (BCD). See Table 6 for decimal to BCD conversion. These registers can be accessed individually or consecutively using burst mode (see *Al\_Burst Register* section).

To enable the alarm, set the AE bit of the Alarm/Clock\_Ctrl Register to 1 (see *Alarm and RTC Programming* section). When an alarm occurs in any mode, the ALIRQ bit of the AL\_Status register will change from 0 to 1, and the  $\overline{INT}$  output will go low unless you are in Sleep mode. If not already awake, the device will wake-up from Sleep mode to Standby mode and  $\overline{INT}$  goes low when the PLL output is available. The crystal oscillator, RTC, wake-up circuitry, reset voltage monitor, low  $V_{DD}$  voltage monitor (if applicable), and the PLL are all powered up in standby mode.

Four alarm registers (Al\_Sec, Al\_Min, Al\_Hour, and Al\_Day) are used to store the preset time value for the alarm function. Bit 7 of the Al\_Sec, Al\_Min, Al\_Hour, Al\_Day registers is the mask bit and is used to program how often the alarm occurs. Table 7 shows how Bit 7 of the four alarm registers should be set for the time of day alarm to occur. Other combinations of mask bits are possible to set different alarms.

**Table 6. BCD Conversion**

DECIMAL DIGIT	BCD
0	0000
1	0001
2	0010
3	0011
4	0100
5	0101
6	0110
7	0111
8	1000
9	1001
	<b>UNUSED CODES</b>
	1010
	1011
	1100
	1101
	1110
	1111

# Low-Power, 16-Bit Multichannel DAS with Internal Reference, 10-Bit DACs, and RTC

Table 7. Common Mask Bits Combinations

ALARM REGISTER MASK BITS (BIT 7)				FUNCTION	HOW OFTEN?
AL_SEC	AL_MIN	M_HOUR	M_DAY		
1	1	1	1	Alarm occurs once per second	Once per second
0	1	1	1	Alarm occurs when seconds match	Once per minute
0	0	1	1	Alarm occurs when minutes and seconds match	Once per hour
0	0	0	1	Alarm occurs when hours, minutes, and seconds match	Once per day
0	0	0	0	Alarm occurs when day, hours, minutes, and seconds match	Once per week

### AL\_BURST REGISTER (01000)

Writing to this register begins the alarm burst mode transfer. All the alarm clock registers are consecutively

read from or written to starting with Bit7 of the Al\_Sec register followed by the Al\_Min register, Al\_Hour register, and finally the Al\_Day register.

### AL\_SEC REGISTER (01001)

FIRST BIT (MSB)					(LSB)			
NAME	M_SEC	10SEC2	10SEC1	10SEC0	SEC3	SEC2	SEC1	SEC0
DEFAULT	0	0	0	0	0	0	0	0

**M\_SEC:** Alarm mask bit. A logic 1 masks out the seconds alarm comparator.

**10SEC[2:0]:** These are the 10-second bits (0–50 seconds) of the alarm.

**SEC[3:0]:** These are the second bits (0–9 seconds) of the alarm.

### AL\_MIN REGISTER (01010)

FIRST BIT (MSB)					(LSB)			
NAME	M_MIN	10MIN2	10MIN1	10MIN0	MIN3	MIN2	MIN1	MIN0
DEFAULT	0	0	0	0	0	0	0	0

**M\_MIN:** Alarm mask bit. A logic 1 masks out the minute alarm comparator.

**10MIN[2:0]:** These are the 10-minute bits (0–50 minutes) of the alarm.

**MIN[3:0]:** These are the minute bits (0–9 minutes) of the alarm.



# Low-Power, 16-Bit Multichannel DAS with Internal Reference, 10-Bit DACs, and RTC

## ALARM/CLOCK\_CTRL REGISTER (01110)

FIRST BIT (MSB)							(LSB)	
NAME	WE	—	—	—	—	—	—	AE
DEFAULT	0	0	0	0	0	0	0	0

**WE:** Write Enable bit. WE must be set to “1” before any write operation to the clock and the alarm register. A logic 0 disables write operations to the clock and alarm registers, including the AE bit. The WE signal takes effect after the 8th SCLK rising edge for an 8-bit write.

**AE:** Alarm Enable bit. A logic 0 disables the alarm function. When AE equals “1”, the ALIRQ bit in the AI\_Status register will be set to 1 whenever the current time matches that of the alarm registers.

### Real-Time Clock (RTC)

The RTC\_Sec, RTC\_Min, RTC\_Hour, RTC\_Date, RTC\_Month, RTC\_Day, RTC\_Year, and RTC\_Century registers can be accessed one register at a time or in Burst mode (see *RTC\_BURST REGISTER* section). The RTC runs continuously and does not stop for read or write operations. To prevent the data from changing during a read operation, complete all read operations on the RTC registers (single register reads and burst reads) in less than 1ms.

Using single reads to read all the RTC registers could lead to errors as much as a century. Since the registers are updated between read operations, the register contents may change before all RTC registers have been read, when reading one register at a time. The most accurate way to get the time information of the RTC registers is with a burst read. In the burst read, a snapshot of the eight RTC registers (RTC\_Sec, RTC\_Min, RTC\_Hour, RTC\_Date, RTC\_Month, RTC\_Day, RTC\_Year, RTC\_Century) is taken once and read

sequentially with the MSB of the Seconds register first. They must all be read out as a group of eight registers of eight bits each, for proper execution of the burst read function. The worst-case error that can occur between the “actual” time and the “reported” time is one second. As with a read operation, using single writes to update the RTC can lead to collisions. To guarantee an accurate update of the RTC, use the Burst Write mode (see *Alarm and RTC Programming* section).

The RTC defaults to 24-hr mode, 00:00:00, Sunday, January 01, 1970 during power-up. January 01, 1970 falls on a Thursday, but since this RTC is not time-based, the default values do not have an impact on the functionality of the clock, and they merely provide some means for testing. If the alarm or RTC registers are programmed to some unused states, the device chooses the default values.

### RTC\_BURST REGISTER (01111)

Writing to this address begins the burst mode transfer. In this mode, all the real-time clock registers are continuously read or written starting with Bit 7 of the RTC\_Sec, RTC\_Min, RTC\_Hour, RTC\_Date, RTC\_Month, RTC\_Day, RTC\_Year, and RTC\_Century registers. When reading, the contents of DIN will be ignored and each register's 8-bit data will be clocked out at DOUT on the falling edge of SCLK (total of 64 clock cycles). When writing, start with the Seconds register MSB first and continue through the Century register (see *Alarm and RTC Programming* section).

### RTC\_SEC REGISTER (10000)

FIRST BIT (MSB)						(LSB)		
NAME	CH	10SEC2	10SEC1	10SEC0	SEC3	SEC2	SEC1	SEC0
DEFAULT	0	0	0	0	0	0	0	0

**CH:** Clock Halt bit. Writing a “1” to CH disables the real-time clock and oscillator.

**10SEC[2:0]:** These are the 10 second bits (10–50 seconds) of the RTC.

**SEC[3:0]:** These are the second bits (0–9 seconds) of the RTC.

# Low-Power, 16-Bit Multichannel DAS with Internal Reference, 10-Bit DACs, and RTC

MAX1407/MAX1408/MAX1409/MAX1414

## RTC\_MIN REGISTER (10001)

	FIRST BIT (MSB)				(LSB)			
NAME	—	10MIN2	10MIN1	10MIN0	MIN3	MIN2	MIN1	MIN0
DEFAULT	0	0	0	0	0	0	0	0

**10MIN[2:0]:** These are the 10 minute bits (0–50 minutes) of the RTC.

**MIN[3:0]:** These are the minute bits (0–9 minutes) of the RTC.

## RTC\_HOUR REGISTER (10010)

	FIRST BIT (MSB)				(LSB)			
NAME	—	12/24	AP	10HR	HR3	HR2	HR1	HR0
DEFAULT	0	0	0	0	0	0	0	0

**12/24:** 12/24-hour mode bit. A logic 1 selects 12-hour mode while a logic 0 selects 24-hour mode. This bit must be the same as the 12-/24-bit of the AL\_Hour register for correct operation.

**AP:** AM/PM-bit. In 12-hour mode, a logic 1 indicates PM and a logic 0 indicates AM. In 24 hour mode, this bit is the second 10-hour bit (20 hours).

**10HR:** This is the 10-hour bit (0–10 hours) of the RTC.

**HR[3:0]:** These are the hour bits (0–9 hours) of the RTC.

## RTC\_DATE REGISTER (10011)

	FIRST BIT (MSB)				(LSB)			
NAME	—	—	10DATE1	10DATE0	DATE3	DATE2	DATE1	DATE0
DEFAULT	0	0	0	0	0	0	0	1

**10DATE[1:0]:** These are the 10 day bits (0–30 days) of the RTC.

**DATE[3:0]:** These are the day bits (0–9 days) of the RTC.

## RTC\_MONTH REGISTER (10100)

	FIRST BIT (MSB)				(LSB)			
NAME	—	—	—	10MO	MO3	MO2	MO1	MO0
DEFAULT	0	0	0	0	0	0	0	1

**10MO:** This is the 10 month bit (0–10 months) of the RTC.

# Low-Power, 16-Bit Multichannel DAS with Internal Reference, 10-Bit DACs, and RTC

**10MO:** This is the 10 month bit (10–12 months)

**MO[3:0]:** These are the month bits (0–9 months) for the RTC. The following table is the Hex code for the twelve months of the year.

<b>MONTH</b>	JAN	FEB	MAR	APR	MAY	JUN
<b>10MO MO[3:0]</b>	01h	02h	03h	04h	05h	06h
<b>MONTH</b>	JUL	AUG	SEP	OCT	NOV	DEC
<b>10MO MO[3:0]</b>	07h	08h	09h	10h	11h	12h

## RTC\_DAY REGISTER (10101)

	FIRST BIT (MSB)					LSB		
NAME	—	—	—	—	—	DAY2	DAY1	DAY0
DEFAULT	0	0	0	0	0	0	0	1

**DAY[2:0]:** These bits select the day of the week (Sunday–Saturday). The following table is the Hex code for day of the week.

<b>AL_DAY</b>	SUN	MON	TUE	WED	THU	FRI	SAT
<b>DAY[2:0]</b>	1h	2h	3h	4h	5h	6h	7h

## RTC\_YEAR REGISTER (10110)

	FIRST BIT (MSB)				LSB			
NAME	10YEAR3	10YEAR2	10YEAR1	10YEAR0	YEAR3	YEAR2	YEAR1	YEAR0
DEFAULT	0	1	1	1	0	0	0	0

**10YEAR[3:0]:** These are the 10 year bits (0–90 years) of the RTC.

**YEAR[3:0]:** These are the year bits (0–9 years) of the RTC.

## RTC\_CENTURY REGISTER (10111)

	FIRST BIT (MSB)				LSB			
NAME	MILL3	MILL2	MILL1	MILL0	CENT3	CENT2	CENT1	CENT0
DEFAULT	0	0	0	1	1	0	0	1

**MILL[3:0]:** These are the millennium bits (0000–9000 years) of the RTC.

**CENT[3:0]:** These are the century bits (000–900 years) of the RTC.

# Low-Power, 16-Bit Multichannel DAS with Internal Reference, 10-Bit DACs, and RTC

MAX1407/MAX1408/MAX1409/MAX1414

**Table 8. Related Bit Values During Specified Mode**

CIRCUIT BLOCK	BIT	INITIAL POWER-UP	SLEEP	STANDBY	IDLE	RUN	WAKE-UP EVENT
32kHz Oscillator	CH	0 (oscillator is on)	N/A	N/A	N/A	N/A	N/A
RTC	CH	0 (RTC is on)	N/A	N/A	N/A	N/A	N/A
Low V <sub>DD</sub> Voltage Monitor (2.7V)	LVDE	1 (2.7V monitor is on)	1 if VM = 0 0 if VM = 1	1	1	1	1
RESET Voltage Monitor (1.8V)	LSDE	0 (1.8V monitor is off)	0 if VM = 0 1 if VM = 1	0 if VM = 0 1 if VM = 1	0 if VM = 0 1 if VM = 1	0 if VM = 0 1 if VM = 1	N/A
Reset Bit	RST	1 (RESET asserted)	N/A	N/A	N/A	N/A	N/A
Low V <sub>DD</sub> Status Bit	LVD	1 (low V <sub>DD</sub> )	N/A	N/A	N/A	N/A	N/A
Voltage-Monitor Threshold Selection	VM	0 (select 2.7V)	N/A	N/A	N/A	N/A	N/A
Bias Circuit	BIASE	Biase = 1 (biase circuit is on)	0	1	1	1	1
PLL	PLLE	1 (PLL is on)	0	1	1	1	1
PLL Output	PLLE	1 (FOUT is enabled)	0	1	1	1	1
SHDN Output	SHDE	1 (SHDN pin = high)	0	1	1	1	1
DAC1	DA1E	0	0	0	1	1	N/A
DAC2	DA2E	0	0	0	1	1	N/A
ADC MUX	MUX	0	0	0	1	1	N/A
Bandgap Reference	REFE	0	0	0	1	1	N/A
Signal-Detect Comparator	SDCE	0	0	0	1	1	N/A
ADC Buffers	BUFE	0	0	0	0	1	N/A
ADC	ADC	0	0	0	0	1	N/A

N/A: Programming the part into these modes would not alter the content of the corresponding bit.

### Power-Control Registers

Table 8 shows the bit values of some key registers in different power modes under various conditions. Use

this as a quick reference when programming the MAX1407/MAX1408/MAX1409/MAX1414 family.

### POWER1 REGISTER (11000)

	FIRST BIT (MSB)						LSB	
NAME	REFE	ADCE	BUFE	MUXE	DA1E	DA2E	—	—
DEFAULT	0	0	0	0	0	0	0	0

**REFE:** Internal Reference Power Enable. When REFE is set to 1, the internal reference is powered up. When REFE is set to 0, the internal reference is powered down allowing an external reference to be connected to REF.

**ADCE:** ADC Power Enable. When ADCE is set to 1, the ADC is powered up. When ADCE is set to 0, the ADC is powered down.

**BUFE:** ADC Input Buffer Power Enable. A logic 1 enables the power-up of the ADC input buffers, while a logic 0 powers-down the buffers.

**MUXE:** Multiplexer enable. A logic 0 disables the multiplexer outputs while a logic 1 enables them.

# Low-Power, 16-Bit Multichannel DAS with Internal Reference, 10-Bit DACs, and RTC

**DA1E:** DAC1 Power Enable. A logic 1 powers DAC1, while a logic 0 powers it down. The output buffer goes high impedance in power-down mode.

**DA2E:** DAC2 Power Enable. A logic 1 powers DAC2, while a logic 0 powers it down. The output buffer goes high impedance in power-down mode.

## POWER2 REGISTER (11001)

	FIRST BIT (MSB)						(LSB)	
NAME	SHDE	PLLE	LVDE	LSDE	SDCE	D0E	VM	BIASE
DEFAULT	1	1	1	0	0	0	0	1

**SHDE:** Shutdown Enable bar. If  $\overline{\text{SHDE}}$  is set to 1,  $\overline{\text{SHDN}}$  is pulled high. A wake-up event such as an assertion of WU1 or WU2, a time-of-day alarm, or by writing to the Power1, Power2, Standby, Idle, or Run registers sets this bit to 1 and drives  $\overline{\text{SHDN}}$  high. If the  $\overline{\text{SHDE}}$  bit is set to 0 in Standby, Idle, or Run mode and the PLL is still operational (PLLE = 1), the  $\overline{\text{SHDN}}$  pin will remain high until 2.93ms ( $t_{\text{DPD}}$ ) after PLLE is set to 0.

**PLLE:** Phase-Locked Loop Power Enable. A logic 1 powers the PLL and enables FOUT while a logic 0 powers down the PLL and disables FOUT. A wake-up event sets this bit to 1. See *Wake-Up* section.

**LVDE:** +2.7V Voltage Monitor Power Enable. A logic 1 powers the +2.7V voltage comparator circuitry, while a logic 0 powers down the +2.7V voltage comparator circuitry. A wake-up event sets LVDE to 1. See *Wake-Up* section.

**LSDE:** +1.8V Voltage Monitor Power Enable. A logic 1 powers the +1.8V voltage comparator circuitry, while a logic 0 powers down the +1.8V voltage comparator circuitry. See *Wake-Up* section.

**SDCE:** Signal-Detect Comparator Power Enable. A logic 1 powers the signal-detect comparator while a logic 0 powers down this comparator.

**D0E:** D0 Enable bit. A logic 0 three-states the D0 output. When D0E is set to "1", the output of D0 is controlled by the state of DBIT in the MUX register. Programming the device in different modes does not alter the state of this bit.

**VM:**  $\overline{\text{RESET}}$  Voltage Monitor Threshold Selection bit. A logic 0 selects a +2.7V threshold while a logic 1 selects a +1.8V threshold for the  $\overline{\text{RESET}}$  Voltage Monitor. The VM bit effects the LVDE and LSDE bits in different modes of operation (see Table 8).

**BIASE:** Bias Enable. A logic 1 powers up the master bias circuit block. A wake-up event sets this bit to a logic 1. See *Wake-Up* section.

## SLEEP REGISTER (11010)

Addressing the Sleep register places the MAX1407/MAX1408/MAX1409/MAX1414 in Sleep mode. This occurs after the last bit of the command byte is clocked into the device. It requires an 8-bit write, no data bits are needed. Sleep mode powers down all functional blocks except for the crystal oscillator, RTC, alarm, serial interface, wake-up circuitry, and  $\overline{\text{RESET}}$  voltage monitor. While in Sleep mode, pulling either WU1 or WU2 low or an alarm event places the device into Standby mode.

## STANDBY REGISTER (11011)

Addressing the Standby register places the MAX1407/MAX1408/MAX1409/MAX1414 in Standby mode. This occurs after the last bit of the address byte is clocked into the device. It requires an 8-bit write, no data bits are needed. Standby mode powers up the same blocks as Sleep mode, as well as the master bias circuitry, the PLL, and the Low  $V_{\text{DD}}$  Voltage Monitor. FOUT is also enabled and  $\overline{\text{SHDN}}$  is set high in Standby mode.

## IDLE REGISTER (11100)

Addressing the Idle register places the MAX1407/MAX1408/MAX1409/MAX1414 in Idle mode. This occurs after the last bit of the address byte is clocked into the device. Requires an 8-bit write, no data bits are needed. In Idle mode, all circuits are powered up with the exception of the ADC and the ADC Input Buffers.

## RUN REGISTER (11101)

Addressing the Run register puts the MAX1407/MAX1408/MAX1409/MAX1414 into Run mode. This occurs after the last bit of the address byte is clocked into the device. Requires an 8-bit write, no data bits are needed. All the functional blocks are powered up in Run mode.

# Low-Power, 16-Bit Multichannel DAS with Internal Reference, 10-Bit DACs, and RTC

## Applications Information

### Alarm and RTC Programming

Three write operations are needed for every update of the ALARM and RTC registers. First set the WE bit of the Alarm/Clock\_CTRL Register to 1. Update the Alarm, RTC, and Alarm/Clock\_CTRL Register with the new values, and then set the WE bit back to 0. This will avoid collisions in setting the time.

### Power-On Reset or Power-Up

At initial power-up, the MAX1407/MAX1408/MAX1409/MAX1414 are in Standby mode. Figure 15 illustrates the timing of various signals during initial Power-Up, Sleep mode, and Wake-Up.  $t_{DPLP}$  after  $AV_{DD}$  exceeds +2.7V,  $\overline{RESET}$  goes high.  $t_{DFON}$  after  $\overline{RESET}$  goes high, FOUT is enabled.  $\overline{INT}$  is enabled to  $t_{DFI}$  after FOUT is enabled.

### Power Modes

The MAX1407/MAX1408/MAX1409/MAX1414 have four distinct power modes, Sleep mode, Standby mode, Idle mode, and Run mode. Table 9 lists the power-on status of the various blocks of the MAX1407/MAX1408/MAX1409/MAX1414. Each individual circuit block can be powered up through the serial interface by writing to the appropriate power registers.

### Sleep Mode

In Sleep mode, only the crystal oscillator, RTC, data registers, wake-up circuitry, and  $\overline{RESET}$  Voltage Monitor are powered up. Sleep mode is entered by addressing the Sleep register through the serial interface. Sleep mode preserves any data in the data registers. To exit Sleep mode, pull either  $\overline{WU1}$  or  $\overline{WU2}$  low or address other Power mode registers (Standby, Idle, Run, Power1, or Power2 registers). Asserting  $\overline{WU1}$  or  $\overline{WU2}$  or the occurrence of a Time of Day Alarm while in Sleep mode places the device in Standby mode.

### Standby Mode

After initial power-up or after exiting Sleep mode through a wake-up event, the MAX1407/MAX1408/MAX1409/MAX1414 are in Standby mode. Standby mode can also be entered by addressing the Standby register. In Standby mode,  $\overline{SHDN}$  is high, FOUT is enabled, the Low  $V_{DD}$  voltage monitor and the PLL are powered up, and  $\overline{INT}$  is low.  $\overline{INT}$  will return to a logic high after the  $\mu P$  begins writing to any register through the serial interface (once a start bit is detected through the serial interface).

### Idle Mode

In Idle mode, only the ADC and ADC input buffers are shutdown. All the other blocks are powered up. Enter Idle mode by addressing the Idle register.

### Run Mode

In Run mode, all the functional blocks are powered up and the ADC is ready to start conversion. Enter Run mode by either writing to the Run register or by individually powering up each circuit through the serial interface.

### Wake-Up

Wake-Up mode is entered whenever a wake-up event, such as an assertion of  $\overline{WU1}$  or  $\overline{WU2}$  or a time-of-day alarm occurs. The Low  $V_{DD}$  monitor, PLL, FOUT are enabled, and  $\overline{SHDN}$  goes high. Different from the Standby mode, the status of the other power blocks remains unchanged.

### Analog Filtering

The digital filter does not provide any rejection close to the harmonics of the modulator sample frequency. However, due to the high oversampling ratio of the MAX1407/MAX1408/MAX1409/MAX1414, these bands occupy only a small fraction of the spectrum and most broadband noise is filtered. Therefore, the analog filtering requirements in front of the MAX1407/MAX1408/MAX1409/MAX1414 are considerably reduced compared to a conventional converter with no on-chip filtering. In addition, because the part's common-mode rejection of 90dB extends out to several kHz, common-mode noise susceptibility in this frequency range is substantially reduced.

Depending on the application, it may be necessary to provide filtering prior to the MAX1407/MAX1408/MAX1409/MAX1414 to eliminate unwanted frequencies the digital filter does not reject. It may also be necessary in some applications to provide additional filtering to ensure that differential noise signals outside the frequency band of interest do not saturate the analog modulator.

If passive components are placed in front of the MAX1407/MAX1408/MAX1409/MAX1414 when the part is used in unbuffered mode, ensure that the source impedance is low enough not to introduce gain errors in the system. This can significantly limit the amount of passive anti-aliasing filtering that can be applied in front of the MAX1407/MAX1408/MAX1409/MAX1414 in unbuffered mode. However, when the part is used in buffered mode, large source impedances will simply result in a small DC offset error (a  $1k\Omega$  source resistance will cause an offset error of less than  $0.5\mu V$ ). Therefore, where significant source impedances are required, operate the device in buffered mode.

# Low-Power, 16-Bit Multichannel DAS with Internal Reference, 10-Bit DACs, and RTC

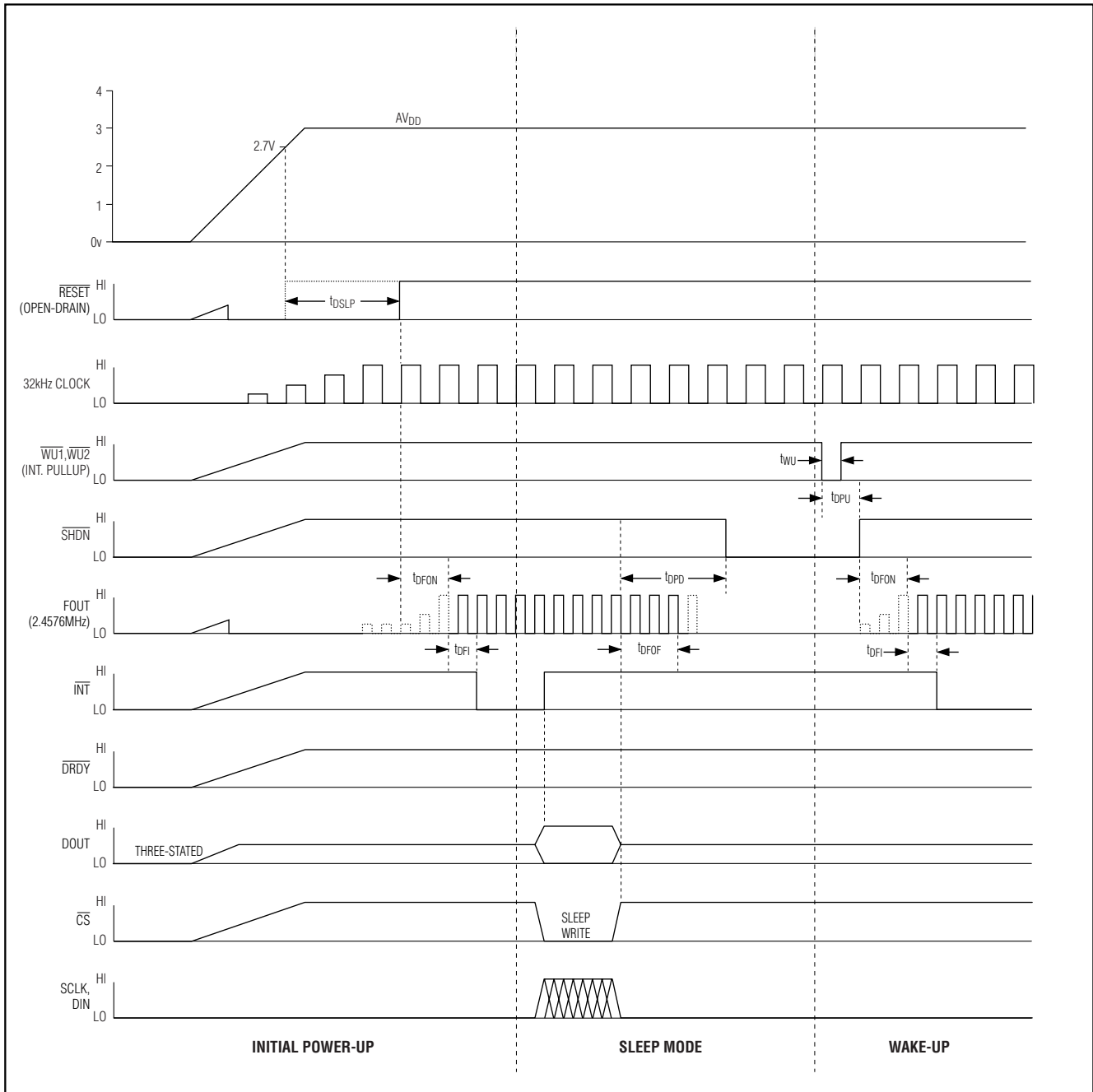

Figure 15. Initial Power-up, Sleep Mode, and Wake-Up Timing Diagram with  $AV_{DD} > 2.7V$

### Dynamic Input Impedance

When designing with the MAX1407/MAX1408/MAX1409/MAX1414, as with any other switched-capacitor ADC input, consider the advantages and disadvantages of series input resistance. A series resistor reduces the transient current impulse to the external driving amplifier. This improves the amplifier phase margin and reduces the possibility of ringing. The resis-

tages of series input resistance. A series resistor reduces the transient current impulse to the external driving amplifier. This improves the amplifier phase margin and reduces the possibility of ringing. The resis-

# Low-Power, 16-Bit Multichannel DAS with Internal Reference, 10-Bit DACs, and RTC

MAX1407/MAX1408/MAX1409/MAX1414

**Table 9. Power States of Individual Blocks at Different Modes of Operation**

CIRCUIT BLOCKS	POWER MODES				
	SLEEP	STANDBY	IDLE	RUN	WAKE-UP EVENT
Serial Interface	x	x	x	x	x
Wake-Up Circuitry	x	x	x	x	x
Crystal Oscillator	x	x	x	x	x
RTC with Alarm	x	x	x	x	x
RESET Voltage Monitor	x	x	x	x	x
Low V <sub>DD</sub> Voltage Monitor	—	x	x	x	x
Master Bias Circuit	—	x	x	x	x
PLL	—	x	x	x	x
FOUT	—	x	x	x	x
SHDN = High	—	x	x	x	x
DAC1	—	—	x	x	N/A
DAC2	—	—	x	x	N/A
Bandgap	—	—	x	x	N/A
Bandgap Buffer	—	—	x	x	N/A
Signal Detect Comparator	—	—	x	x	N/A
ADC Multiplexer	—	—	x	x	N/A
ADC Input Buffers	—	—	—	x	N/A
ADC	—	—	—	x	N/A

x = powered-up

N/A = programming the parts into the wake-up mode would not alter the content of these blocks

**Table 10. R<sub>EXT</sub>, C<sub>EXT</sub> Values for Less than 16-Bit Gain Error in Unbuffered Mode**

PGA GAIN (V/V)	EXTERNAL RESISTANCE R <sub>EXT</sub> (kΩ)				
	C <sub>EXT</sub> = 0pF	C <sub>EXT</sub> = 50pF	C <sub>EXT</sub> = 100pF	C <sub>EXT</sub> = 200pF	C <sub>EXT</sub> = 500pF
1	194	56	33	19	9
2	100	30	16	9	4.5

tor spreads the transient-load current from the sampler over time due to the RC time constant of the circuit. However, an improperly chosen series resistance can hinder performance in high-resolution converters. The settling time of the RC network can limit the speed at which the converter can operate properly, or reduce the settling accuracy of the sampler. In practice, this means ensuring that the RC time constant, resulting from the product of the driving source impedance and the capacitance presented by both the device's input and any external capacitance is sufficiently small to allow settling to the desired accuracy. Table 10 summarizes the maximum allowable series resistance vs.

external shunt capacitance for each different gain setting in order to ensure 16-bit performance in unbuffered mode (for 60sps conversion rate).

### Performing a Conversion or Offset-Calibration with the ADC

Upon power-up, the MAX1407/MAX1408/MAX1409/MAX1414 are in Standby mode. At this point, the ADC register default settings are set for a normal ADC conversion (MODE = 0), conversion rate of 30Hz (RATE = 0), gain of 1/3 V/V (GAIN [00]), input buffers bypassed and powered down (BUFP = BUFN = 0), and unipolar mode

# Low-Power, 16-Bit Multichannel DAS with Internal Reference, 10-Bit DACs, and RTC

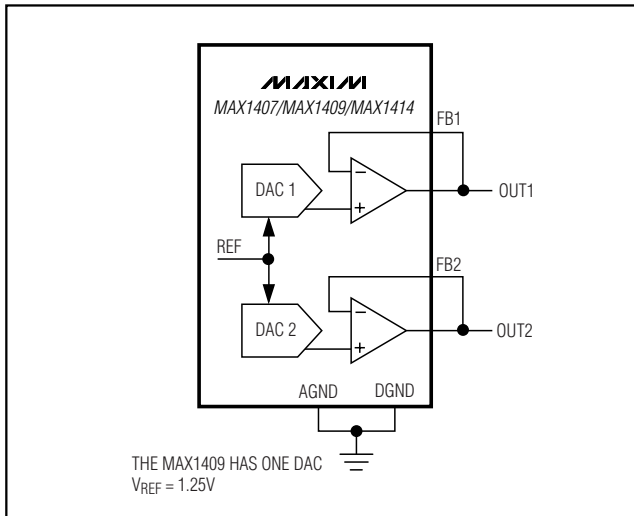

Figure 16. Unipolar Output Circuit

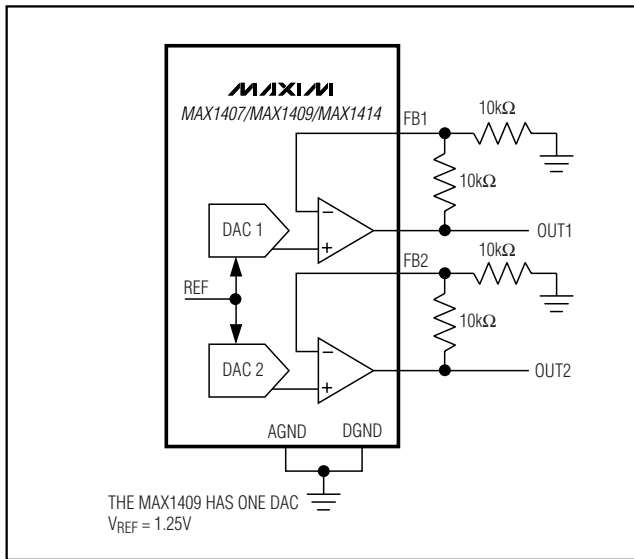

Figure 17. Unipolar Rail-to-Rail Output Circuit

(BIP = 0). To initiate an ADC conversion: 1) Enter Run mode by addressing the Run register 2) Select the desired channels for conversion by writing to the MUX register, (e.g., 94h selects IN1 for the positive channel and IN2 for the negative channel) 3) Initiate the conversion by writing to the ADC register, (e.g., 01h). The first conversion result becomes available in 100ms. The ADC

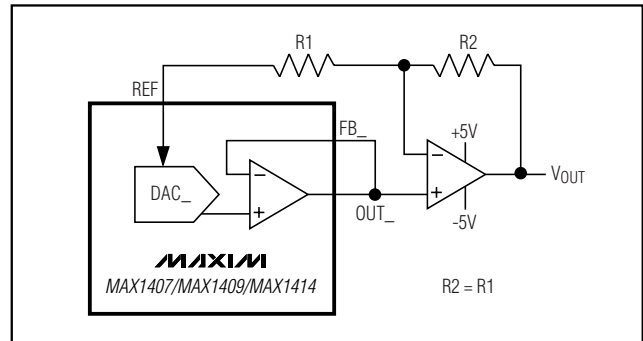

Figure 18. Bipolar Output Circuit

will keep doing conversions at a rate of 30Hz until powered down.

To perform an on-chip offset calibration on a specific configuration, write to the ADC register with the MODE bit and STA1 bit set to 1. The ADC will do one calibration using the inputs to the ADC specified in the MUX register and then stop. The calibration result will be stored in the Offset register in two's complement form. Subsequent ADC conversion results will have the offset value subtracted before written to the DATA register. The MODE bit will be reset to 0 automatically upon completion of the calibration. The ADC is now ready for a normal conversion.

The offset for a given ADC configuration can be stored by the  $\mu$ P to avoid another ADC recalibration. Write the stored offset back to the offset register when returning back to that particular ADC configuration where the calibration was taken. Subsequent ADC conversion results will have the offset value subtracted before they are written to the DATA register.

### DAC Unipolar Output

For a unipolar output, the output voltages and the reference have the same polarity. Figure 16 shows the MAX1407/MAX1409/MAX1414s' unipolar output circuit, which is also the typical operating circuit for the DACs. Table 11 lists some unipolar input codes and their corresponding output voltages.

For larger output swing see Figure 17. This circuit shows the output amplifiers configured with a closed-loop gain of  $+2V/V$  to provide 0 to 2.5V full-scale range with the 1.25V reference.

### DAC Bipolar Output

The MAX1407/MAX1409/MAX1414 DAC outputs can be configured for bipolar operation using the application circuit on Figure 18:

# Low-Power, 16-Bit Multichannel DAS with Internal Reference, 10-Bit DACs, and RTC

MAX1407/MAX1408/MAX1409/MAX1414

**Table 11. Unipolar Code Table**

DAC CONTENTS		ANALOG OUTPUT
MSB	LSB	
1111	1111 11	+VREF(1023/1024)
1000	0000 01	+VREF (513/1024)
1000	0000 00	+VREF (512/1024) = +VREF/2
0111	1111 11	+VREF (511/1024)
0000	0000 01	+VREF (1/1024)
0000	0000 00	0

**Table 12. Bipolar Code Table**

DAC CONTENTS		ANALOG OUTPUT
MSB	LSB	
1111	1111 11	+VREF (511/512)
1000	0000 01	+VREF (1/512)
1000	0000 00	0
0111	1111 11	-VREF (1/512)
0000	0000 01	-VREF (511/512)
0000	0000 00	-VREF (512/512) = -VREF

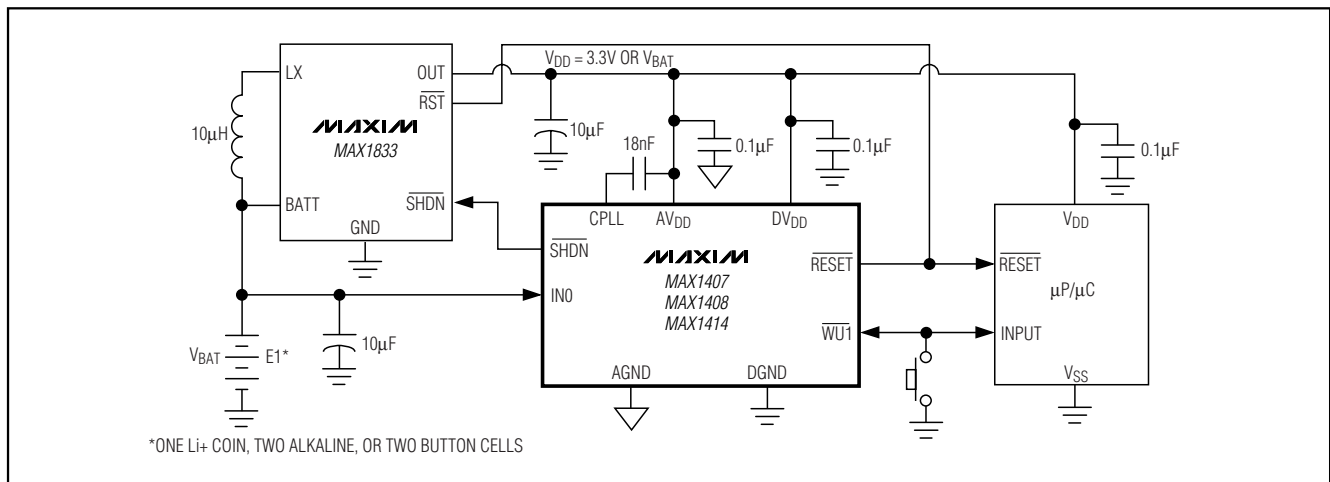

Figure 19. Power-Supply Circuit Using MAX1833 Step-Up DC-DC Converter

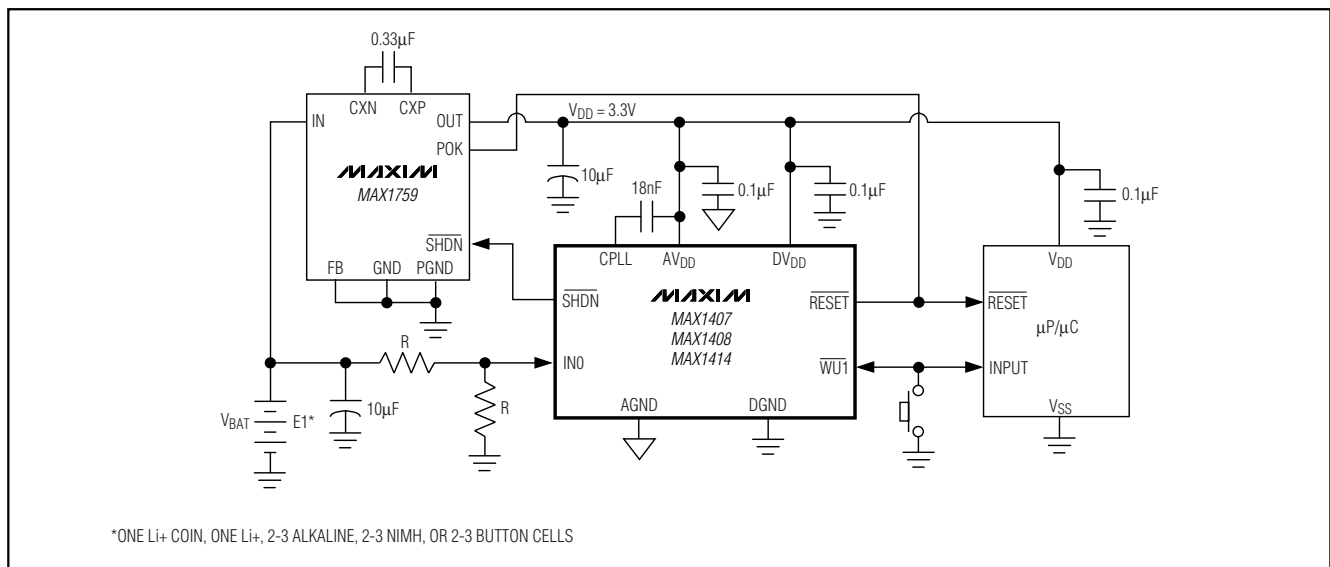

Figure 20. Power-Supply Circuit Using MAX1759 Buck-Boost DC-DC Converter

# Low-Power, 16-Bit Multichannel DAS with Internal Reference, 10-Bit DACs, and RTC

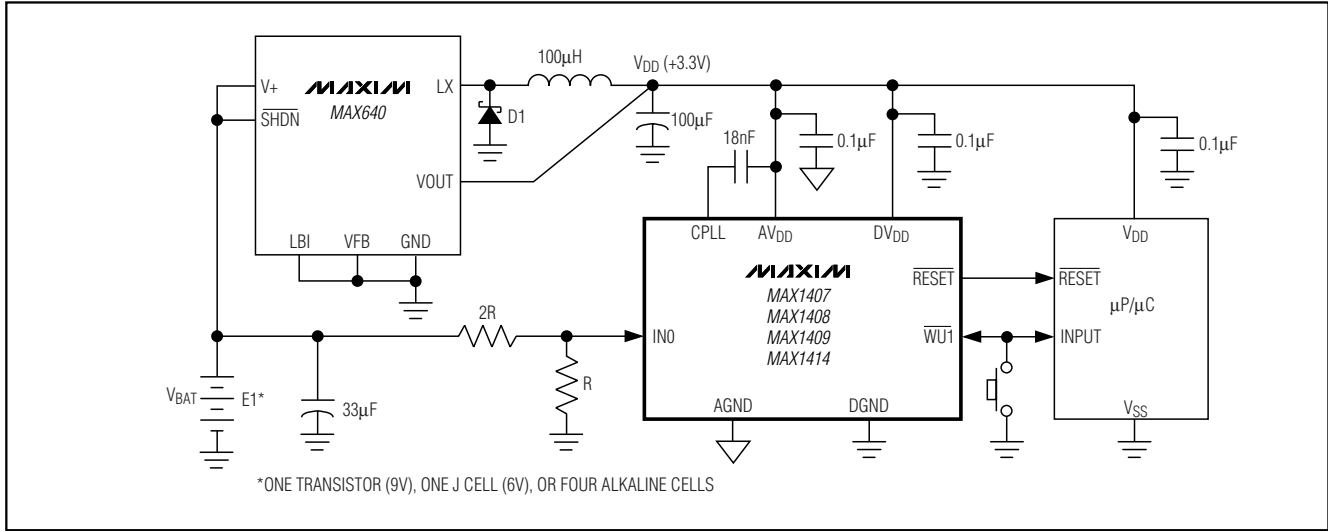

Figure 21. Power-Supply Circuit Using MAX640 Step-Down DC-DC Converter

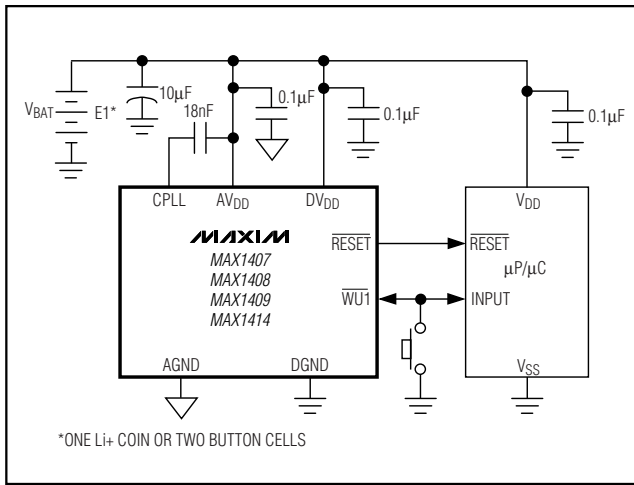

Figure 22. Power-Supply Circuit Using Direct Battery Connection

$$V_{OUT} = V_{REF} \left[ \left( \frac{2NB}{1024} \right) - 1 \right]$$

where NB is the decimal value of the DAC's binary input code. Table 12 shows digital codes (offset binary) and corresponding output voltages for Figure 18 assuming  $R1 = R2$ .

## Power Supplies

Power to the MAX1407/MAX1408/MAX1409/MAX1414 family can be supplied in a number of ways. Figures 19,

20, 21, and 22 are power-supply circuits using a step-up converter, buck-boost converter, step-down converter, and a direct battery, respectively. Choose the correct power-supply circuit for your specific application.

Connect the MAX1407/MAX1408/MAX1409/MAX1414 AVDD and DVDD power supplies together. While the latch-up performance of the MAX1407/MAX1408/MAX1409/MAX1414 is adequate, it is important that power is applied to the device before the analog input signals (IN\_) to avoid latch-up. If this is not possible, limit the current flow into any of these pins to 50mA.

## Electrochemical Sensor Operation

The MAX1407/MAX1408/MAX1409/MAX1414 family interface with electrochemical sensors. The 10-bit DACs with the force/sense buffers have the flexibility to connect to many different types of sensors. Figure 23 shows how to interface with a two electrode potentiostat. A single DAC is required to set the bias across the sensor relative to ground and an external precision resistor completes the transimpedance amplifier configuration to convert the current generated by the sensor to a voltage to be measured by the ADC. The induced error from this source is negligible due to FB1's extremely low input bias current. Internally, the ADC can differentially measure directly across the external transimpedance resistor,  $R_F$ , eliminating any errors due to voltages drifting over time, temperature, or supply voltage. Figure 24 shows a two electrode potentiostat application that is driven at the working electrode and measured at the counter electrode. With this application, the DAC connected to the working electrode is configured in unity gain and the DAC connected to the

# Low-Power, 16-Bit Multichannel DAS with Internal Reference, 10-Bit DACs, and RTC

MAX1407/MAX1408/MAX1409/MAX1414

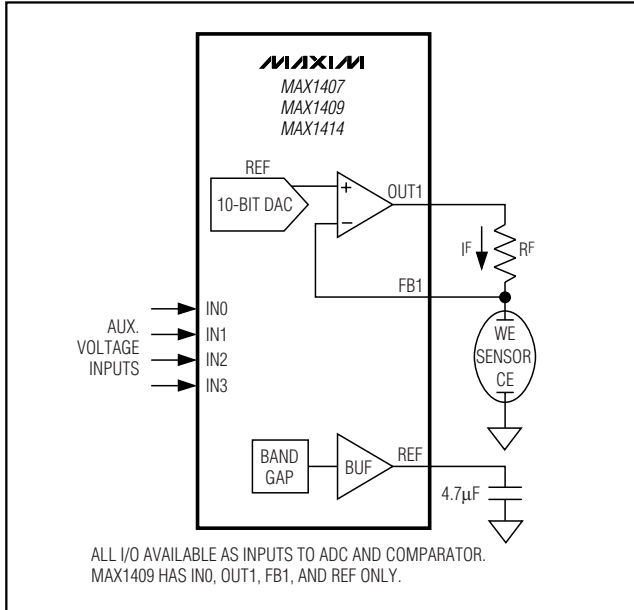

Figure 23. Self-Biased Two Electrode Potentiostat Application

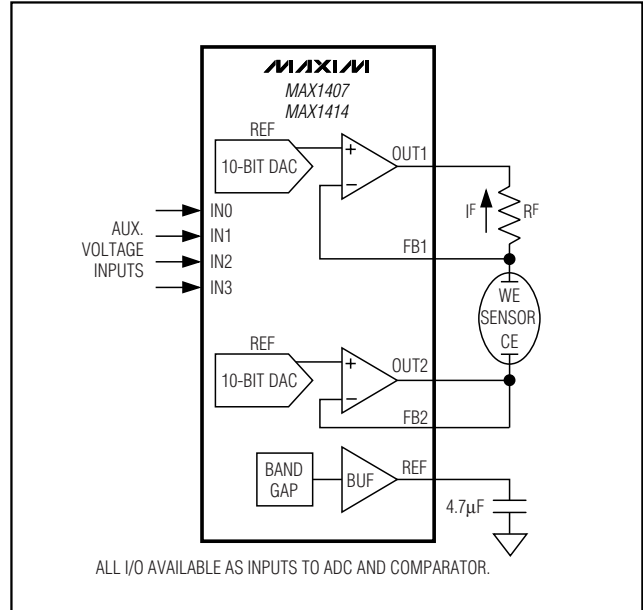

Figure 24. Driven Two Electrode Potentiostat Application

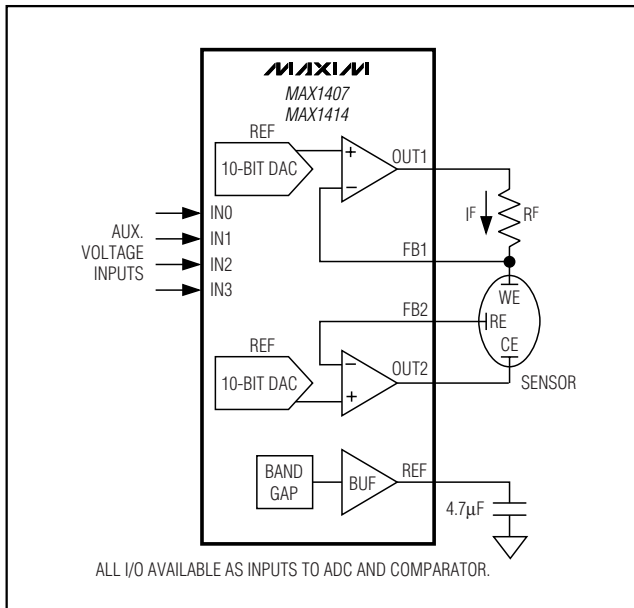

Figure 25. Driven Three Electrode Potentiostat Application

counter electrode is configured as a transimpedance amplifier to measure the current. Figure 25 shows a three electrode potentiostat application that is driven at all the electrodes and measured at the working electrode. With this application, the DAC connected to the working elec-

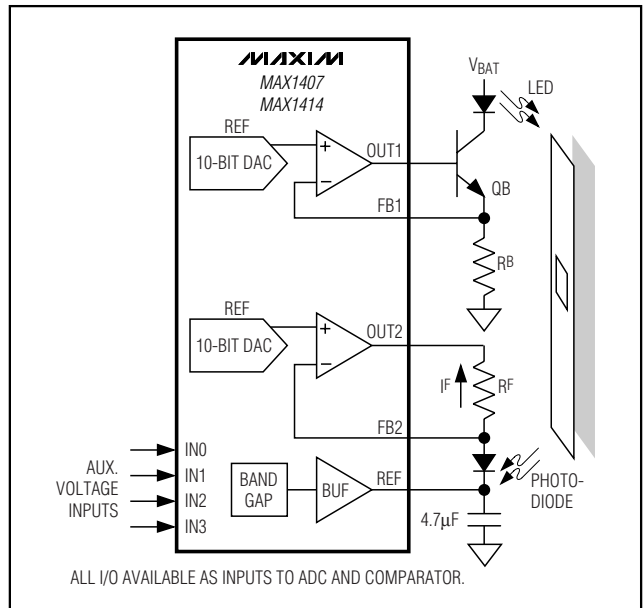

Figure 26. Optical Reflectometry Application

trode sets the bias voltage relative to the reference electrode and also measures the current that the sensor produces. The DAC connected to the reference and counter electrodes takes advantage of the force/sense outputs to

# Low-Power, 16-Bit Multichannel DAS with Internal Reference, 10-Bit DACs, and RTC

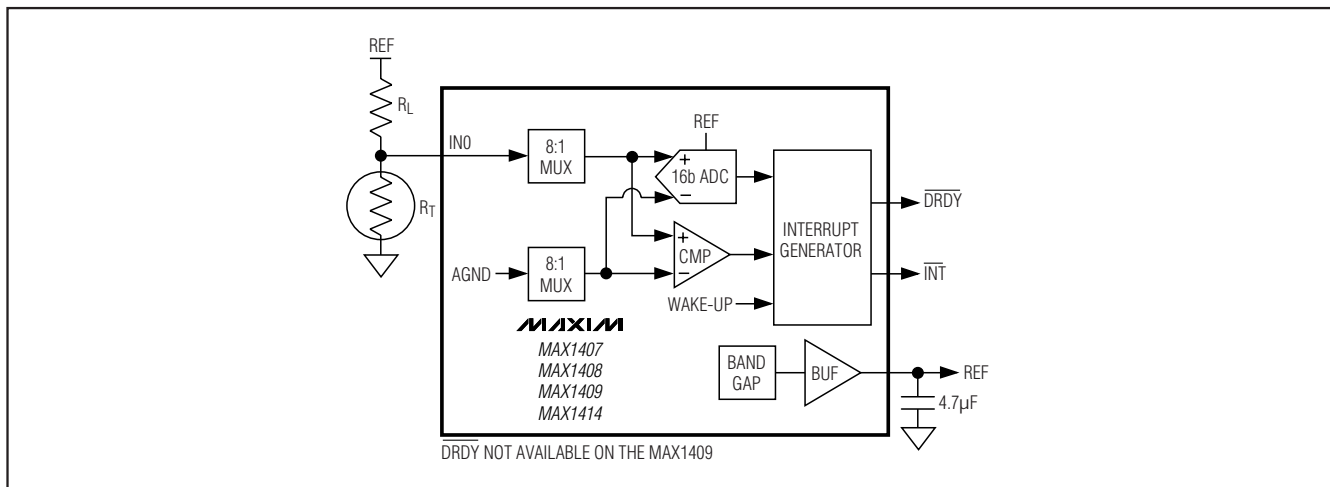

Figure 27. Thermistor Application Circuit

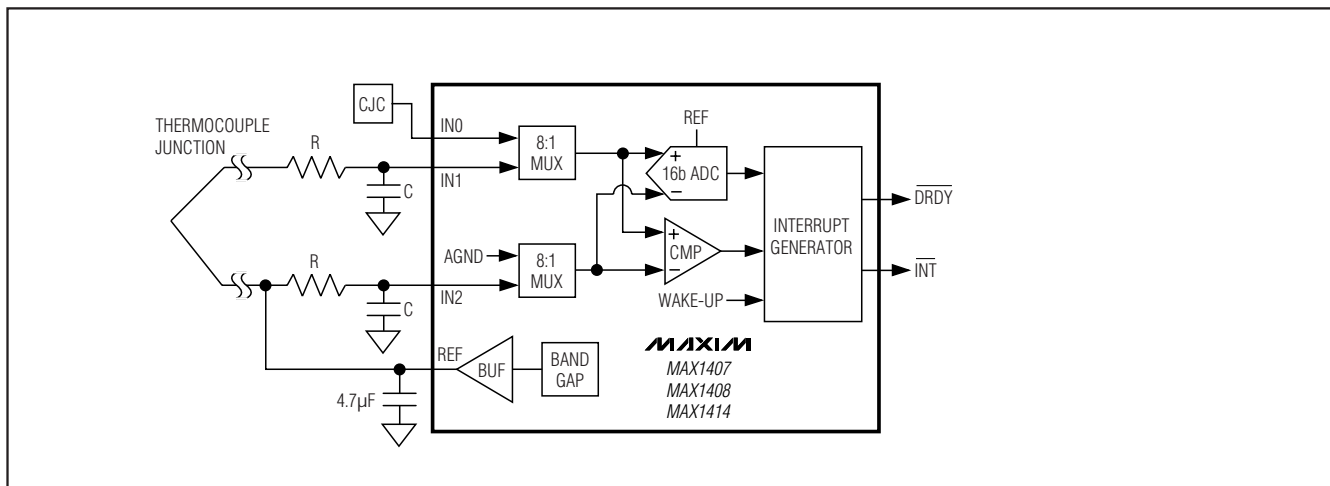

Figure 28. Thermocouple Application Circuit

maintain the reference electrode bias voltage by virtue of the feedback path through the sensor.

### Optical Reflectometry

Figure 26 illustrates the MAX1407/MAX1414 in an optical reflectometry application. The first DAC is used with an external transistor to set the bias current through the LED and the second DAC is used to properly bias and convert the photodiode current to a voltage measured by the ADC. The low input bias current into the DAC feedback pin (FB2) allows the measurement of very small currents. The DACs provide the flexibility in setting an accurate and stable LED current and adjusting the bias across the

photodiode. Set the LED bias current externally if the MAX1409 is used in this application.

### Thermistor Measurement

A thermistor connected in a half-bridge configuration as shown in Figure 27 is used to measure temperatures very accurately with the MAX1407/MAX1408/MAX1409/MAX1414. The internal reference drives the thermistor as well as the ADC, so the reference variation is cancelled out when calculating the temperature. The only significant errors are from the  $R_L$  resistor and the thermistor itself. The ADC performs a unipolar conversion with the PGA set to a gain of  $1V/V$ .

# Low-Power, 16-Bit Multichannel DAS with Internal Reference, 10-Bit DACs, and RTC

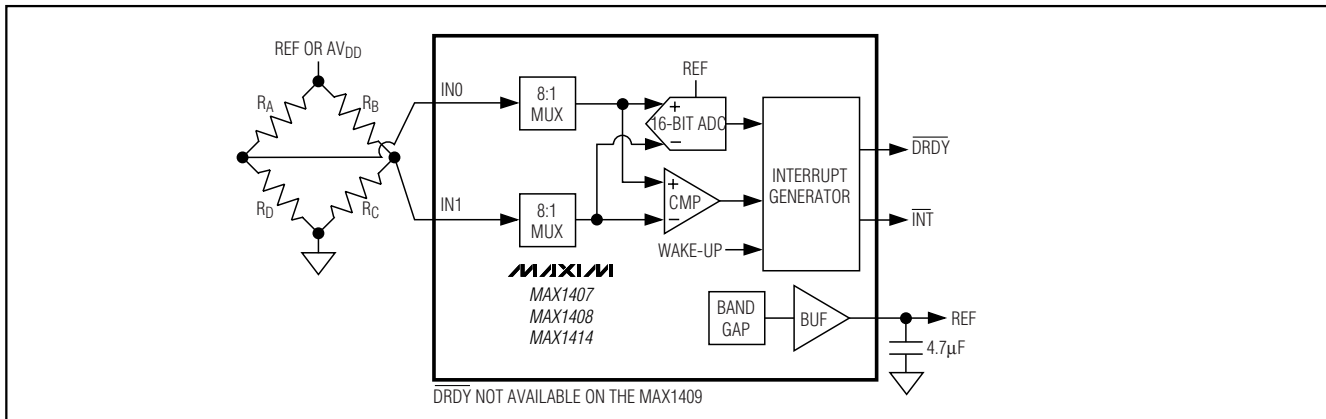

Figure 29. Strain-Gauge Application Circuit

## Thermocouple Measurement

Figure 28 shows a thermocouple connected to the differential inputs of the MAX1407/MAX1408/MAX1409/MAX1414. In this application, the internal buffers are enabled to allow for the decoupling shown at the input. The decoupling eliminates noise pickup from the thermocouple. With the internal buffers enabled, the input common-mode range is reduced so the IN2 input is biased to the internal reference voltage at +1.25V. When the buffer is enabled, the IN1 input is limited to +1.4V.

## Strain-Gauge Operation

Connect the differential inputs of the MAX1407/MAX1408/MAX1409/MAX1414 to the bridge network of the strain gauge as shown in Figure 29. When connected to the internal reference, the ADC can resolve below 10µV at the differential inputs. The internal buffers provide a high input impedance as long as the signal is within the reduced common-mode range of the input buffers. The bridge may also be driven directly from the supply voltage. In this configuration, the ADC first measures the supply voltage and then the differential input in sequence, and then calculates the ratio.

## Grounding and Layout

For best performance, use printed circuit boards with separate analog and digital ground planes. The device performance will be highly degraded when using wire-board boards.

Design the printed circuit board so that the analog and digital sections are separated and confined to different areas of the board. Join the digital and analog ground planes at one point. If the MAX1407/MAX1408/MAX1409/MAX1414 is the only device requiring an AGND to DGND connection, then the ground planes should be connected at the AGND pin of the MAX1407/

MAX1408/MAX1409/MAX1414. In systems where multiple devices require AGND to DGND connections, the connection should still be made at only one point. Make the star ground as close to the MAX1407/MAX1408/MAX1409/MAX1414 as possible.

Avoid running digital lines under the device because these may couple noise onto the die. Run the analog ground plane under the MAX1407/MAX1408/MAX1409/MAX1414 to minimize coupling of digital noise. Make the power-supply lines to the MAX1407/MAX1408/MAX1409/MAX1414 as wide as possible to provide low-impedance paths and reduce the effects of glitches on the power-supply line.

Shield fast switching signals such as clocks with digital ground to avoid radiating noise to other sections of the board. Avoid running clock signals near the analog inputs. Avoid crossover of digital and analog signals. Traces on opposite sides of the board should run at right angles to each other. This will reduce the effects of feedthrough on the board. A microstrip technique is best, but is not always possible with double-sided boards. In this technique, the component side of the board is dedicated to ground planes while signals are placed on the solder side.

Good coupling is important when using high-resolution ADCs. Decouple all analog supplies with 1µF capacitors in parallel with 0.1µF HF ceramic capacitors to AGND. Place these components as close to the device as possible to achieve the best decoupling.

## Crystal Layout

Since it is possible for noise to be coupled onto the crystal pins, care must be taken when placing the external crystal on a PC board layout. It is very important to follow a few basic layout guidelines concerning

# Low-Power, 16-Bit Multichannel DAS with Internal Reference, 10-Bit DACs, and RTC

the placement of the crystal on the PC board layout to insure that extra clock “ticks” do not couple onto the crystal pins.

- 1) It is important to place the crystal as close as possible to the CLKIN and CLKOUT pins. Keeping the trace lengths between the crystal and pins as small as possible reduces the probability of noise coupling by reducing the length of the “antennae”. Keeping the trace lengths small also decreases the amount of stray capacitance.
- 2) Keep the crystal bond pads and trace width to the CLKIN and CLKOUT pins as small as possible. The larger these bond pads and traces are, the more likely it is that noise can couple from adjacent signals.
- 3) If possible, place a guard ring (connect to ground) around the crystal. This helps to isolate the crystal from noise coupled from adjacent signals.
- 4) Insure that no signals on other PC board layers run directly below the crystal or below the traces to the CLKIN and CLKOUT pins. The more the crystal is isolated from other signals on the board, the less likely it is that noise will be coupled into the crystal. There should be a minimum of 0.200 inches between any digital signal and any trace connected

to CLKIN or CLKOUT.

- 5) It may also be helpful to place a local ground plane on the PC board layer immediately below the crystal guard ring. This helps to isolate the crystal from noise coupling from signals on other PC board layers. **Note:** The ground plane needs to be in the vicinity of the crystal only and not on the entire board.

## Definitions

### Integral Nonlinearity

Integral nonlinearity (INL) is the deviation of the values on an actual transfer function (with offset and gain error removed) from a straight line. This straight line can be either a best straight-line fit or a line drawn between the endpoints of the transfer function, once offset and gain errors have been nullified. The static linearity parameters for the MAX1407/MAX1408/MAX1409/MAX1414 are measured using the endpoint method.

### Differential Nonlinearity

Differential nonlinearity (DNL) is the difference between an actual step width and the ideal value of 1LSB. A DNL error specification of less than 1LSB guarantees no missing codes and a monotonic transfer function.

## Pin Configurations (continued)

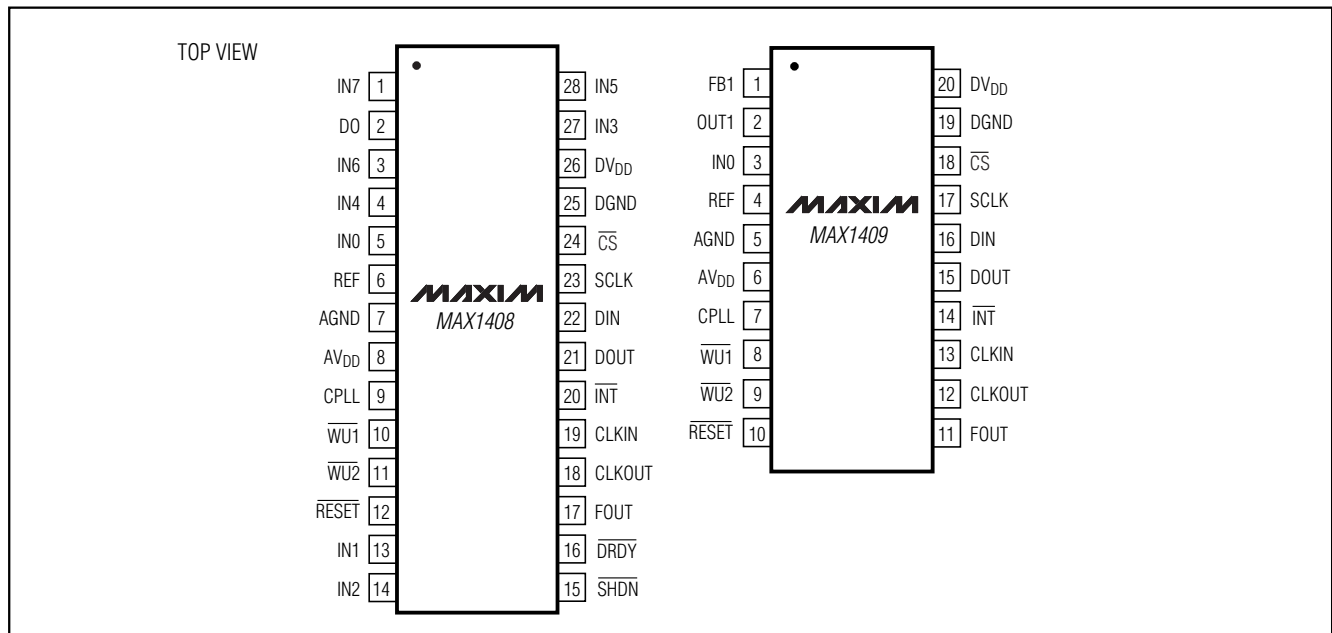

# Low-Power, 16-Bit Multichannel DAS with Internal Reference, 10-Bit DACs, and RTC

## Typical Operating Circuit

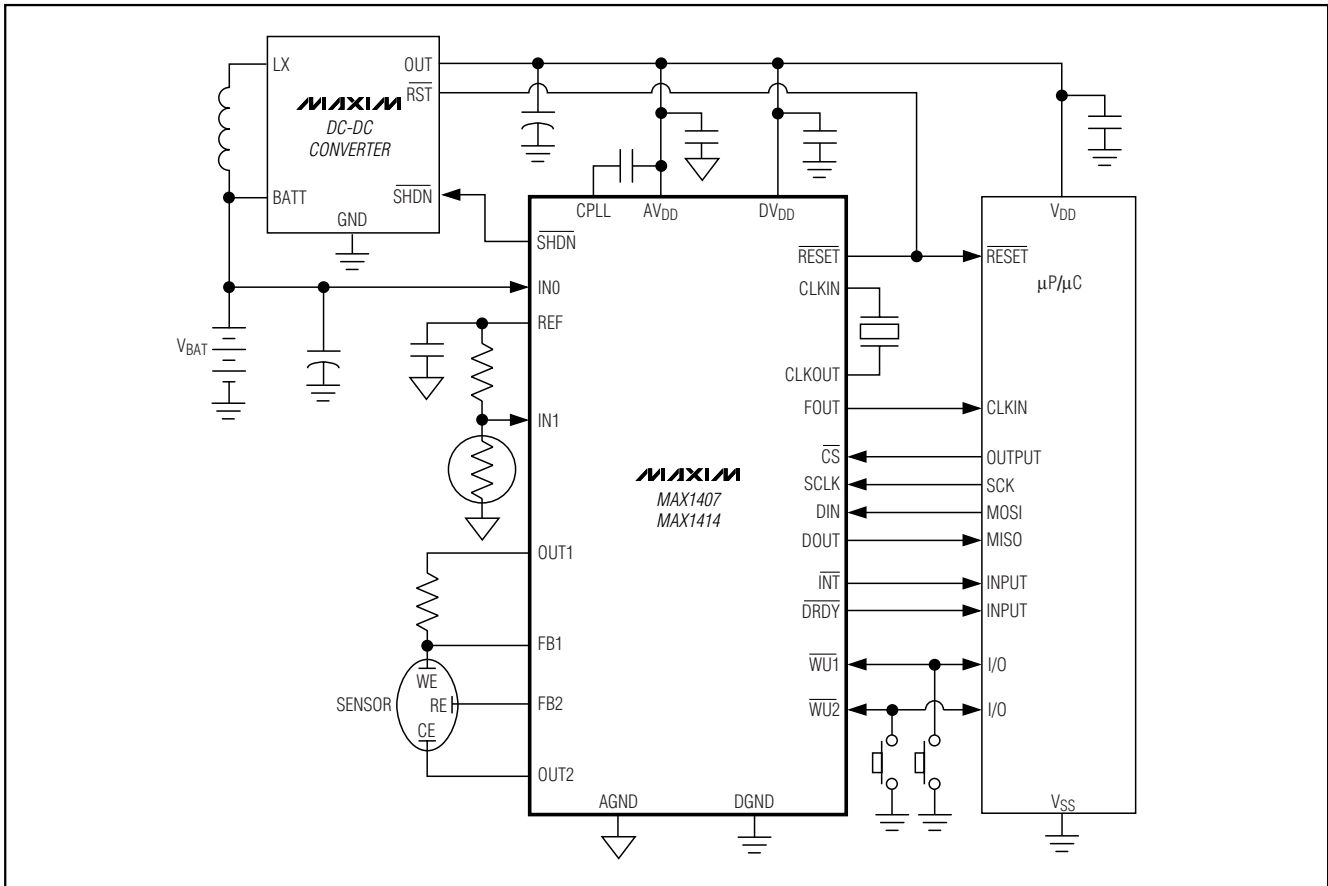

MAX1407/MAX1408/MAX1409/MAX1414

# Low-Power, 16-Bit Multichannel DAS with Internal Reference, 10-Bit DACs, and RTC

## Package Information

DIM	INCHES		MILLIMETERS	
	MIN	MAX	MIN	MAX
A	0.068	0.078	1.73	1.99
A1	0.002	0.008	0.05	0.21
B	0.010	0.015	0.25	0.38
C	0.004	0.008	0.09	0.20
D	SEE VARIATIONS			
E	0.205	0.209	5.20	5.38
e	0.0256	BSC	0.65	BSC
H	0.301	0.311	7.65	7.90
L	0.025	0.037	0.63	0.95
$\alpha$	0°	8°	0°	8°

D	INCHES		MILLIMETERS		N
	MIN	MAX	MIN	MAX	
D	0.239	0.249	6.07	6.33	14L
D	0.239	0.249	6.07	6.33	16L
D	0.278	0.289	7.07	7.33	20L
D	0.317	0.328	8.07	8.33	24L
D	0.397	0.407	10.07	10.33	28L

NOTES:  
 1. D&E DO NOT INCLUDE MOLD FLASH.  
 2. MOLD FLASH OR PROTRUSIONS NOT TO EXCEED .15mm (.006").  
 3. CONTROLLING DIMENSION: MILLIMETERS.  
 4. MEETS JEDEC MO150.

<b>MAXIM</b>		
<small>PROPRIETARY INFORMATION</small>		
<small>TITLE:</small>		
PACKAGE OUTLINE, SSOP, 5.3x.65mm		
<small>APPROVAL</small>	<small>DOCUMENT CONTROL NO.</small>	<small>REV</small>
	21-0056	B 1/1

SSOPFS

Maxim cannot assume responsibility for use of any circuitry other than circuitry entirely embodied in a Maxim product. No circuit patent licenses are implied. Maxim reserves the right to change the circuitry and specifications without notice at any time.

48 \_\_\_\_\_ **Maxim Integrated Products, 120 San Gabriel Drive, Sunnyvale, CA 94086 408-737-7600**

## Looking for pricing, stock, or lifecycle information?

Click below to explore more details on WIN SOURCE:

- ⊖ [View MAX1414CAI+ on WIN SOURCE](#)
- ⊖ [Maxim Integrated Information](#)

## Optimize Your Supply Chain with WIN SOURCE Solutions

- ✓ Global Sourcing Solution
- ✓ Obsolete Management
- ✓ Cost Control Management
- ✓ Shortage Management
- ✓ Alternative Solution
- ✓ Excess Inventory Management