



**THE DATASHEET OF
MAX14830EVKIT#**



MAX14830 Evaluation Kit

Evaluates: MAX14830

General Description

The MAX14830 evaluation kit (EV kit) provides a proven design to evaluate the MAX14830 quad-channel universal asynchronous receiver-transmitter (UART) IC. Each UART contains 128 words of receive and transmit first-in/first-out (FIFO) buffer that can be controlled through the SPI or I²C interface. Each of the four UARTs are selected through SPI or I²C in-band addressing.

Each of the four UARTs can interface with an IO-Link[®] master transceiver or an RS-485/RS-232 multiprotocol transceiver. The EV kit contains on-board IO-Link master transceivers, RS-485/RS-232 multiprotocol transceivers, and double-pole/double-throw (DPDT) switches are used to select between the IO link and RS-485/RS-232 transceivers.

The EV kit operates from a +3.3V and a +24V DC supply and requires 100mA of current from each supply. This EV kit requires a user-supplied SPI/I²C controller and software.

The EV kit comes with a MAX14830ETM+ installed.

Features

- ◆ +3.3V and +24V Power-Supply Operation
- ◆ On-Board IO-Link Master Transceivers (MAX14824)
- ◆ On-Board RS-485/RS-232 Multiprotocol Transceivers (MAX3160E)
- ◆ PCB Header for User-Supplied SPI- and I²C-Compatible Signals
- ◆ PCB Headers for UART Signals (J1)
- ◆ Evaluates the MAX14830 in a 48-Pin TQFN (7mm x 7mm) Package
- ◆ RoHS Compliant
- ◆ Proven PCB Layout
- ◆ Fully Assembled and Tested

[Ordering Information](#) appears at end of data sheet.

Component List

DESIGNATION	QTY	DESCRIPTION
AARDVARK	1	10-pin (2 x 5) header
C1	1	10 μ F \pm 20%, 50V X7R ceramic capacitor (2220) TDK C5750X7R1H106M
C2	1	10 μ F \pm 10%, 6.3V X7R ceramic capacitor (0805) Murata GRM21BR70J106K
C3–C6, C8–C11, C20, C22, C24, C26	12	1 μ F \pm 10%, 10V X7R ceramic capacitors (0603) Murata GRM188R71A105K
C12–C15	4	1 μ F \pm 10%, 50V X7R ceramic capacitors (0805) Murata GRM21BR71H105K
C16–C19, C21, C23, C25, C27–C42	23	0.1 μ F \pm 10%, 50V X7R ceramic capacitors (0603) Murata GRM188R71H104K
C43, C45, C47, C49	4	270pF \pm 5%, 50V C0G ceramic capacitors (0603) TDK C1608C0G1H271J
C44, C46, C48, C50	4	1nF \pm 5%, 50V X7R ceramic capacitors (0603) KEMET C0603C102J5RACTU

DESIGNATION	QTY	DESCRIPTION
D1–D12	12	Green LEDs (0603)
D13, D14, D17, D18, D21, D22, D25, D26	8	40V, 2A Schottky diodes Diodes, Inc. DFLS240
D15, D19, D23, D27, D29	5	33V, 4A TVS diodes (SOT23) Semtech SDC36C.TCT
GPIO	1	5-pin header
IOLINK0– IOLINK3	4	4-pin headers
J1	1	2 x 24 right-angle socket strip
JU1–JU10	10	2-pin headers
JU11–JU17	7	3-pin headers
JU18, JU19	2	4-way, 5-pin headers
JU20	0	Not installed, 2-pin header
R1–R4	4	1k Ω \pm 5% resistors (0603)
R5–R10	6	2k Ω \pm 5% resistors (0603)
R11–R26	16	10k Ω \pm 5% resistors (0603)
R27	1	0.5 Ω \pm 5% resistor (2010) IRC LRC-LR2010LF-01-R500-J
RS0–RS3	4	6-pin headers
SPI/I ² C	1	12-pin header

IO-Link is a registered trademark of Profibus User Organization (PNO).

For pricing, delivery, and ordering information, please contact Maxim Direct at 1-888-629-4642, or visit Maxim's website at www.maxim-ic.com.

MAX14830 Evaluation Kit

Evaluates: MAX14830

Component List (continued)

DESIGNATION	QTY	DESCRIPTION
SW1	1	Momentary pushbutton switch
U1	1	Quad SPI/I ² C UART with 128-word FIFOs (48 TQFN-EP) Maxim MAX14830ETM+
U2, U3	2	Quad DPDT switches (36 TQFN-EP) Maxim MAX4761ETX+
U4-U7	4	IO-Link master transceivers (24 TQFN-EP) Maxim MAX14824GTG+

DESIGNATION	QTY	DESCRIPTION
U8-U11	4	Multiprotocol transceivers (20 SSOP) Maxim MAX3160EEAP+
U12	1	SPDT analog switch (6 SOT23) Maxim MAX4624EUT+ (Top Mark: AADL)
Y1	1	3.6864MHz crystal
—	19	Shunts
—	1	PCB: MAX14830 EVALUATION KIT

Component Suppliers

SUPPLIER	PHONE	WEBSITE
Diodes Incorporated	805-446-4800	www.diodes.com
IRC, Inc.	361-992-7900	www.irctt.com
KEMET Corp.	864-963-6300	www.kemet.com
Murata Electronics North America, Inc.	770-436-1300	www.murata-northamerica.com
Semtech Corporation	805-495-2111	www.semtech.com
TDK Corp.	847-803-6100	www.component.tdk.com

Note: Indicate that you are using the MAX14830 when contacting these component suppliers.

Quick Start

Required Equipment

- MAX14830 EV kit
- User-supplied SPI interface controller
- +3.3V, 100mA DC power supply
- +24V, 100mA DC power supply

Procedure

The EV kit is fully assembled and tested. Follow the steps below to verify board operation. **Caution: Do not turn on the power supply until all connections are completed.**

- 1) Verify that shunts are installed in their default positions, as shown in Table 1.
- 2) Connect the output of the SPI interface controller to the SPI/I²C 12-pin header, as follows:
 - Connect CSN to pin 5 of SPI/I²C
 - Connect MISO to pin 6 of SPI/I²C
 - Connect SCLK to pin 7 of SPI/I²C
 - Connect MOSI to pin 10 of SPI/I²C
- 3) Turn on the +3.3V power supply and set the supply to +3.3V, then disable the power supply.
- 4) Connect the positive terminal of the +3.3V power supply to the +3.3V PCB pad on the EV kit. Connect the negative terminal of the power supply to the GND PCB pad.
- 5) Turn on the +24V power supply and set the supply to +24V, then disable the power supply.
- 6) Connect the positive terminal of the +24V power supply to the +24V PCB pad on the EV kit. Connect the negative terminal of the power supply to the GND PCB pad.
- 7) Enable both power supplies.
- 8) Send SPI signals to the EV kit through the SPI/I²C 12-pin header.
- 9) Detect the output at the IOLINK1-IOLINK4 4-pin headers.
- 10) The EV kit is now ready for additional testing.

MAX14830 Evaluation Kit

Evaluates: MAX14830

Table 1. Default Shunt Positions (JU1–JU19)

JUMPER	SHUNT POSITION	PIN CONNECTION	EV KIT FUNCTION
JU1	Not installed	U1, pin 1 (SPI/I ² C) connected to +3.3V through resistor R11.	SPI mode.
JU2	Not installed	U2, pin 4 and U3, pin 4 (INA) connected to GND through resistor R12.	IO link selected.
JU3–JU10	Not installed	D5–D12 (anodes) not connected.	D5–D12 not used.
JU11	1-2	U12, pin 1 (IN) connected to +3.3V.	SPI/I ² C header, pin 5 (CSN) connected to JU19, pin 3 (CS).
JU12	1-2	SPI/I ² C header, pin 6 (MISO) connected to U1, pin 3.	U1 connected to SPI interface controller (MISO).
JU13	1-2	SPI/I ² C header, pin 7 (SCLK) connected to U1, pin 4.	U1 connected to SPI interface controller (SCLK).
JU14–JU17	1-2	Install shunts in the 1-2 default position (JU14–JU17 are “don’t care” when operating in SPI mode).	
JU18	1-3	SPI/I ² C header, pin 10 (MOSI) connected to U1, pin 6.	U1 connected to SPI interface controller (MOSI).
JU19	1-3	U12, pin 6 (CS) connected to U1, pin 5.	U1 connected to SPI interface controller (CSN).

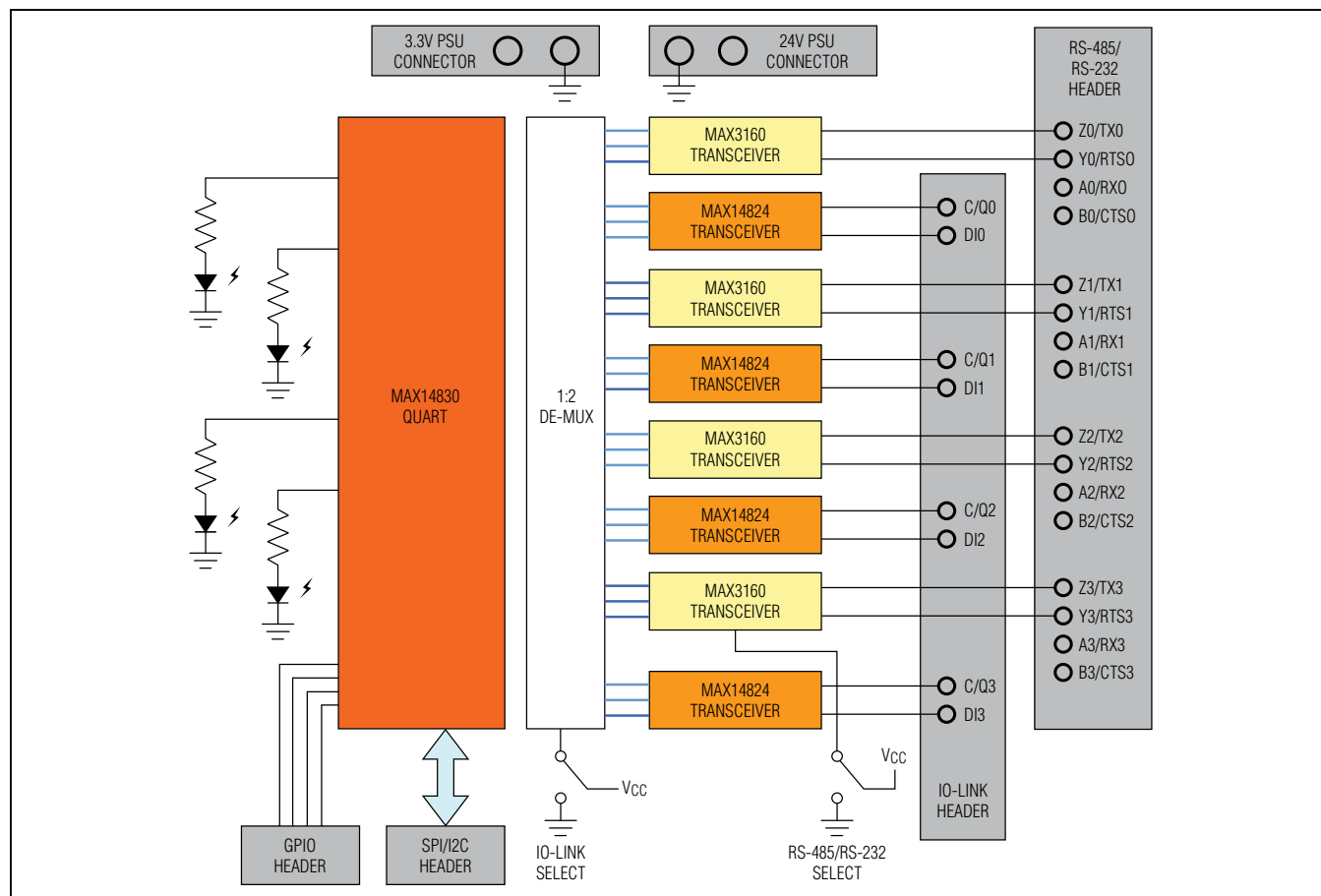

Figure 1. System Setup Example

MAX14830 Evaluation Kit

Evaluates: MAX14830

Detailed Description of Hardware

The MAX14830 EV kit provides a proven design to evaluate the MAX14830 IC. The IC is an advanced quad-channel UART with each UART containing 128 words of receive and transmit FIFO buffer that can be controlled through SPI or I²C. Each of the four UARTs is selected through SPI or I²C in-band addressing.

Each of the four UARTs can interface with an IO-Link master transceiver or an RS-485/RS-232 multiprotocol transceiver. The EV kit contains four on-board IO-Link master transceivers, four RS-485/RS-232 multiprotocol transceivers, and 8-channel DPDT switches to select between the IO link and RS-485/RS-232 transceivers.

Jumper Selection

SPI/I²C Operating Mode (SPI/I²C)

Jumper JU1 selects the IC's operating mode. The operating mode is selectable between SPI and I²C. See Table 2 for JU1 shunt positions.

Table 2. JU1 Jumper Selection (SPI/I²C)

SHUNT POSITION	U1-1 (SPI/I ² C) CONNECTED TO	OPERATING MODE
Not installed*	+3.3V (through resistor R11)	SPI
Installed	GND	I ² C

*Default position.

Table 3. JU2 Jumper Selection (INA)

SHUNT POSITION	U2-4 AND U3-4 (INA) CONNECTED TO	OUTPUT INTERFACE
Not installed*	GND (through resistor R12)	IO link
Installed	+3.3V	RS-485/RS-232

*Default position.

Table 5. JU11 Jumper Selection (CSN)

SHUNT POSITION	U12-1 (IN) CONNECTED TO	SPI/I ² C HEADER, PIN 5 (CSN) CONNECTED TO	CSN SERVING
1-2*	+3.3V	U1, pin 5 ($\overline{CS}/A0$) (through jumper JU19)	UART
2-3	GND	U4-U7, pin 6 (\overline{CS})	IO links
Not installed	SPI/I ² C header, pin 11 (CSN_SEL)	CSN connection selected by CSN_SEL	Determined by CSN_SEL

*Default position.

IO Link and RS-485/RS-232 Output Interface Selection (INA)

Jumper JU2 selects the IC's output interface. The output interface is selectable between the IO link and RS-485/RS-232 transceivers. See Table 3 for JU2 shunt positions.

IO-Link Signal Indicators ((C/Q)/(DI))

Jumpers JU3-JU10 connect or disconnect the IO-Link signal (C/Q)/(DI) from their respective LED indicators. Install shunts to connect or remove shunts to disconnect the IO-Link signal from their respective LED indicators. Table 4 lists the correspondence between jumpers JU3-JU10 to their respective IO-Link signal and LED indicators.

UART and IO-Link Chip-Select Signal (CSN)

Jumper JU11 selects the destination for the CSN (chip-select signal on the SPI/I²C header, pin 5). The CSN chip-select signal can be set to serve either the UART (MAX14830) or the four IO links (MAX14824) using JU11. See Table 5 for JU11 shunt positions.

Table 4. JU3-JU10 Jumper Legend (LEDs)

JUMPER*	SIGNAL/POWER	LED
JU3	IOLINK0 C/Q	D5
JU4	IOLINK0 DI	D6
JU5	IOLINK1 C/Q	D7
JU6	IOLINK1 DI	D8
JU7	IOLINK2 C/Q	D9
JU8	IOLINK2 DI	D10
JU9	IOLINK3 C/Q	D11
JU10	IOLINK3 DI	D12

*Install shunts to connect or remove (default) shunts to disconnect from LED.

MAX14830 Evaluation Kit

Evaluates: MAX14830

MISO/SDA

Jumper JU12 configures the MISO/SDA pin (U1, pin 3) and routes the signal to the respective headers. See Table 6 for JU12 shunt positions.

SCLK/SCL

Jumper JU13 configures the SCLK/SCL pin (U1, pin 4) and routes the signal to the respective headers. See Table 7 for JU13 shunt positions.

MOSI/A1

Jumpers JU14 and JU18 configure the MOSI/A1 pin (U1, pin 6). See Table 8 for JU14 and JU18 shunt positions.

$\overline{CS}/A0$

Jumpers JU15 and JU19 configure the $\overline{CS}/A0$ pin (U1, pin 5). See Table 9 for JU15 and JU19 shunt positions.

Table 6. JU12 Jumper Selection (MISO/SDA)

SHUNT POSITION	MISO/SDA PIN CONNECTED TO	OPERATING MODE
1-2*	SPI/ $\overline{I2C}$ header, pin 6 (MISO)	SPI
2-3	SPI/ $\overline{I2C}$ header, pin 9 (SDA)	I ² C
Not installed	Not connected	Not selected

*Default position.

Table 7. JU13 Jumper Selection (SCLK/SCL)

SHUNT POSITION	SCLK/SCL PIN CONNECTED TO	OPERATING MODE
1-2*	SPI/ $\overline{I2C}$ header, pin 7 (SCLK)	SPI
2-3	SPI/ $\overline{I2C}$ header, pin 8 (SCL)	I ² C
Not installed	Not connected	Not selected

*Default position.

Table 8. JU14 and JU18 Jumper Selection (MOSI/A1)

SHUNT POSITION		MOSI/A1 PIN CONNECTED TO	OPERATING MODE
JU18	JU14		
1-3	Not used	SPI/ $\overline{I2C}$ header, pin 10 (MOSI)	SPI
1-2	Not used	+3.3V	I ² C*
1-5	Not used	GND	
1-4	1-2	SPI/ $\overline{I2C}$ header, pin 9 (SDA)	
	2-3	SPI/ $\overline{I2C}$ header, pin 8 (SCL)	
Not installed	Not installed	Not connected	Not selected
Not installed	Not used	Not connected	Not selected

*Refer to the MAX14830 IC data sheet for the corresponding I²C slave address.

Table 9. JU15 and JU19 Jumper Selection ($\overline{CS}/A0$)

SHUNT POSITION		$\overline{CS}/A0$ PIN CONNECTED TO	OPERATING MODE
JU19	JU15		
1-3	Not used	SPI/ $\overline{I2C}$ header, pin 5 (CSN) (with shunt installed on pins 1-2 of JU11)	SPI
1-2	Not used	+3.3V	I ² C*
1-5	Not used	GND	
1-4	1-2	SPI/ $\overline{I2C}$ header, pin 9 (SDA)	
	2-3	SPI/ $\overline{I2C}$ header, pin 8 (SCL)	
Not installed	Not installed	Not connected	Not selected
Not installed	Not used	Not connected	Not selected

*Refer to the MAX14830 IC data sheet for the corresponding I²C slave address.

MAX14830 Evaluation Kit

Evaluates: MAX14830

RS-485/RS-232 Selection

Jumper JU16 selects between the RS-485 and RS-232 output protocols for the EV kit. See Table 10 for JU16 shunt positions.

Table 10. JU16 Jumper Selection (RS-485/RS-232)

SHUNT POSITION	RS-485/RS-232 PINS CONNECTED TO	OUTPUT PROTOCOL
1-2*	+3.3V	RS-485
2-3	GND	RS-232
Not installed	Not connected	Not selected

*Default position.

Half Duplex and Full Duplex (HDPLX)

Jumper JU17 selects either a half-duplex or full-duplex output protocol for the EV kit. See Table 11 for JU17 shunt positions.

Table 11. JU17 Jumper Selection (HDPLX)

SHUNT POSITION	HDPLX PINS CONNECTED TO	OUTPUT PROTOCOL
1-2*	+3.3V	Half duplex
2-3	GND	Full duplex
Not installed	Not connected	Not selected

*Default position.

MAX14830 Evaluation Kit

Evaluates: MAX14830

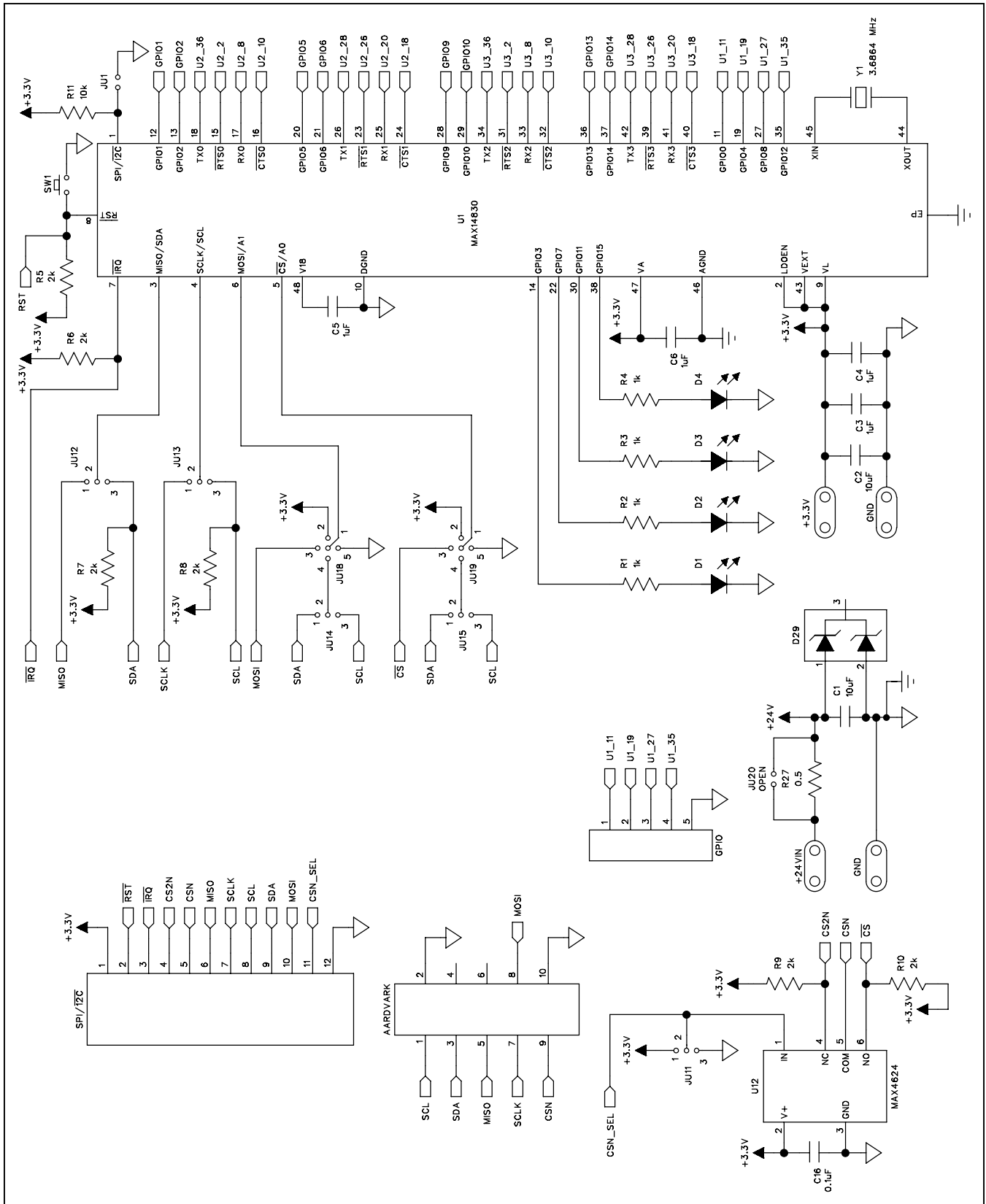

Figure 2a. MAX14830 EV Kit Schematic (Sheet 1 of 4)

MAX14830 Evaluation Kit

Evaluates: MAX14830

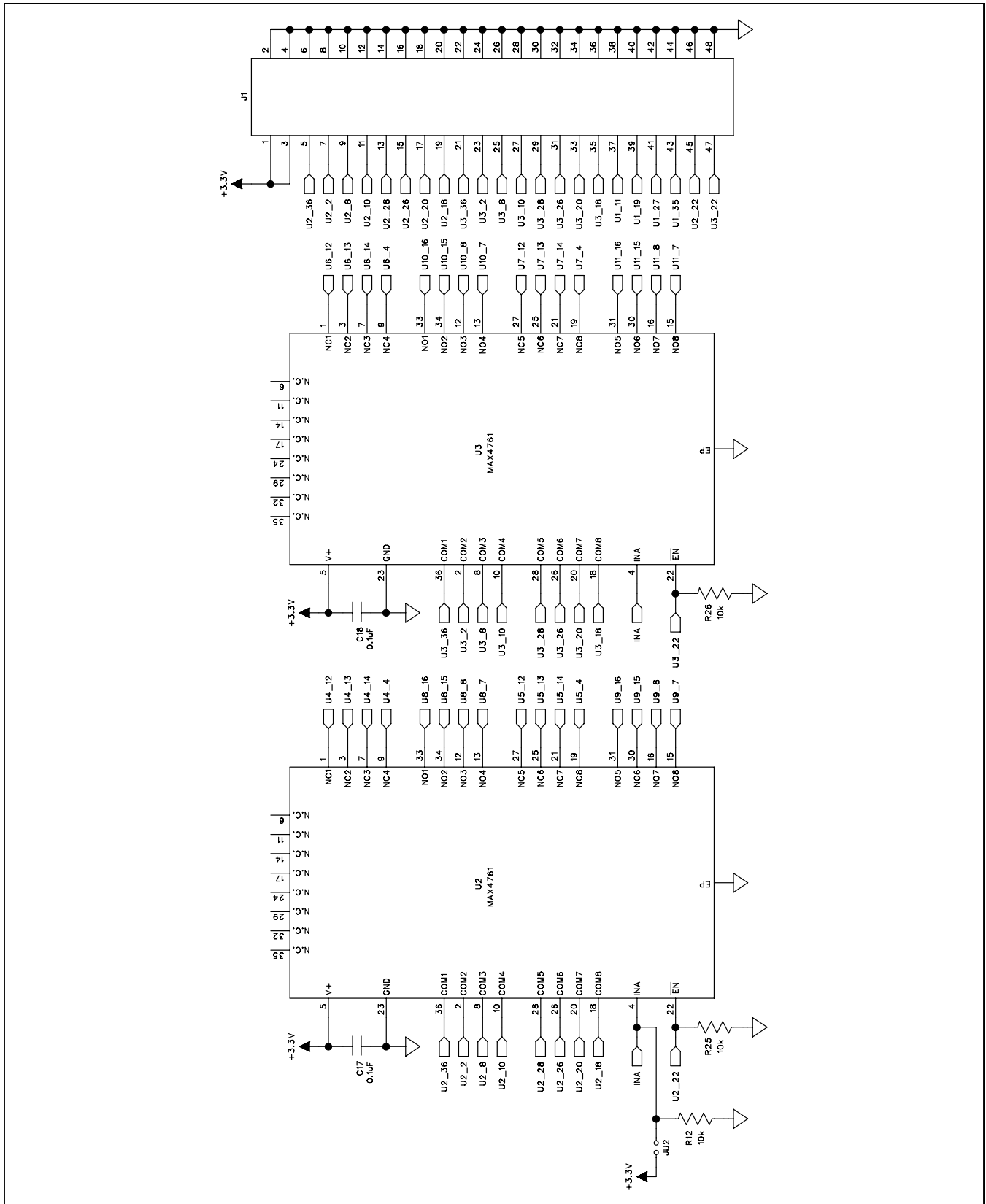

Figure 2b. MAX14830 EV Kit Schematic (Sheet 2 of 4)

MAX14830 Evaluation Kit

Evaluates: MAX14830

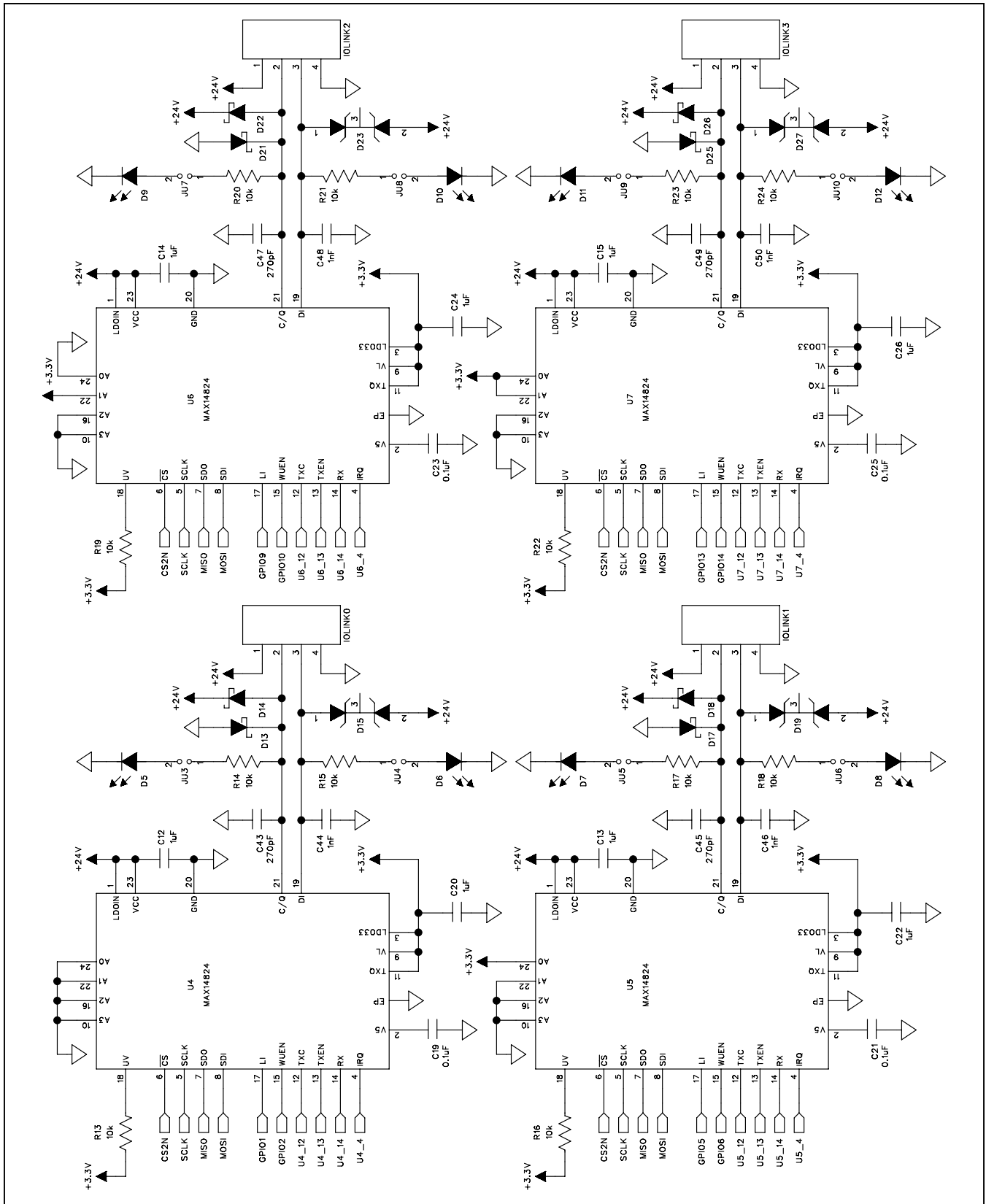

Figure 2c. MAX14830 EV Kit Schematic (Sheet 3 of 4)

MAX14830 Evaluation Kit

Evaluates: MAX14830

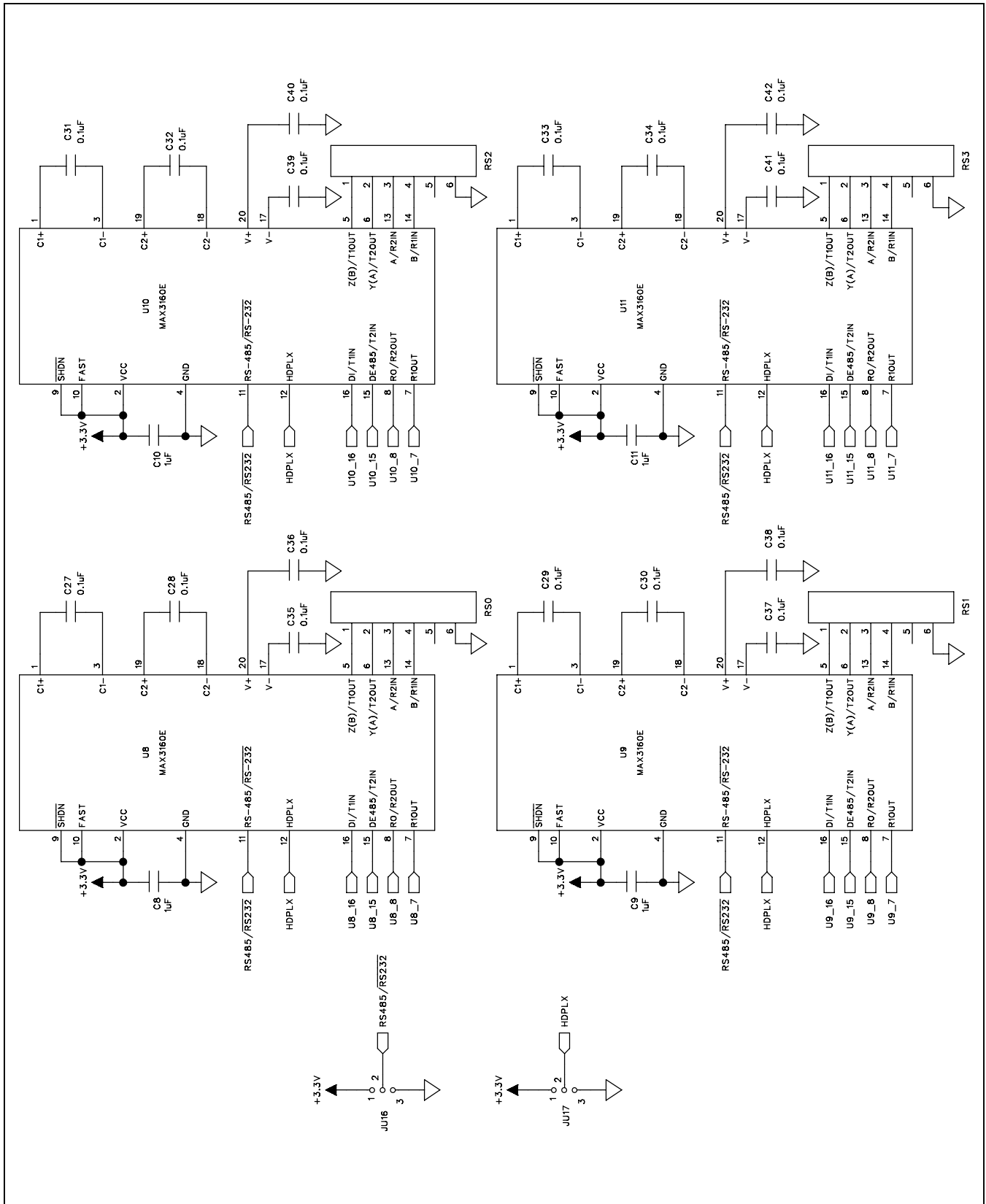

Figure 2d. MAX14830 EV Kit Schematic (Sheet 4 of 4)

MAX14830 Evaluation Kit

Evaluates: MAX14830

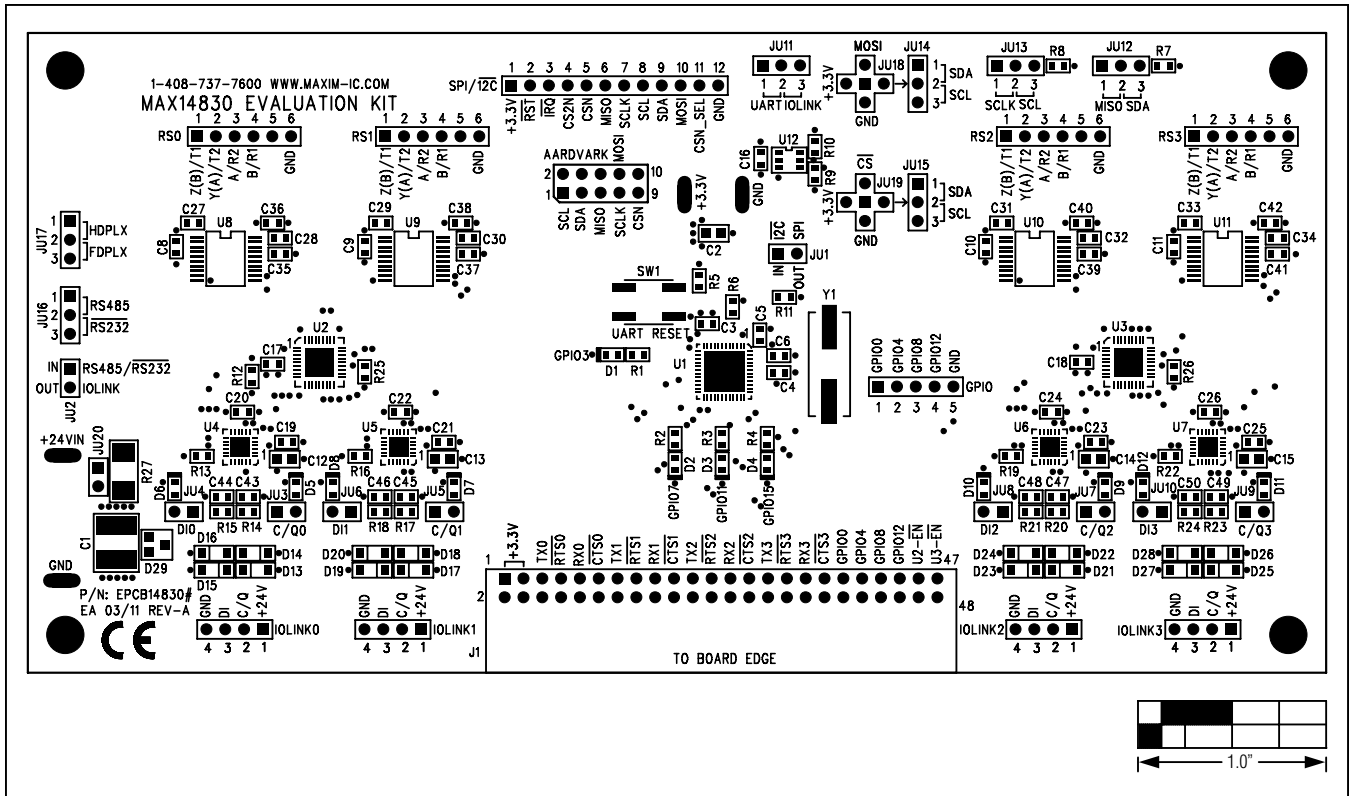

Figure 3. MAX14830 EV Kit Component Placement Guide—Component Side

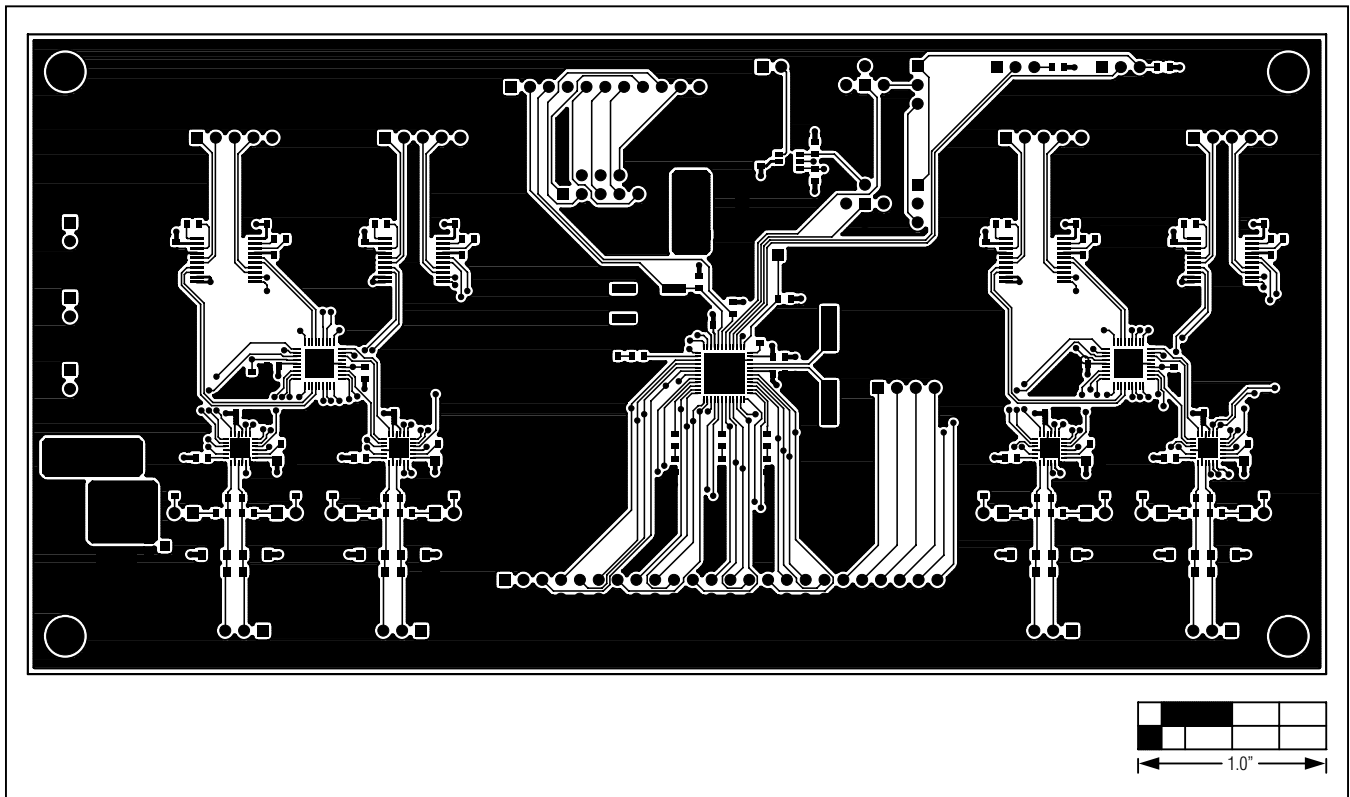

Figure 4. MAX14830 EV Kit PCB Layout—Component Side

MAX14830 Evaluation Kit

Evaluates: MAX14830

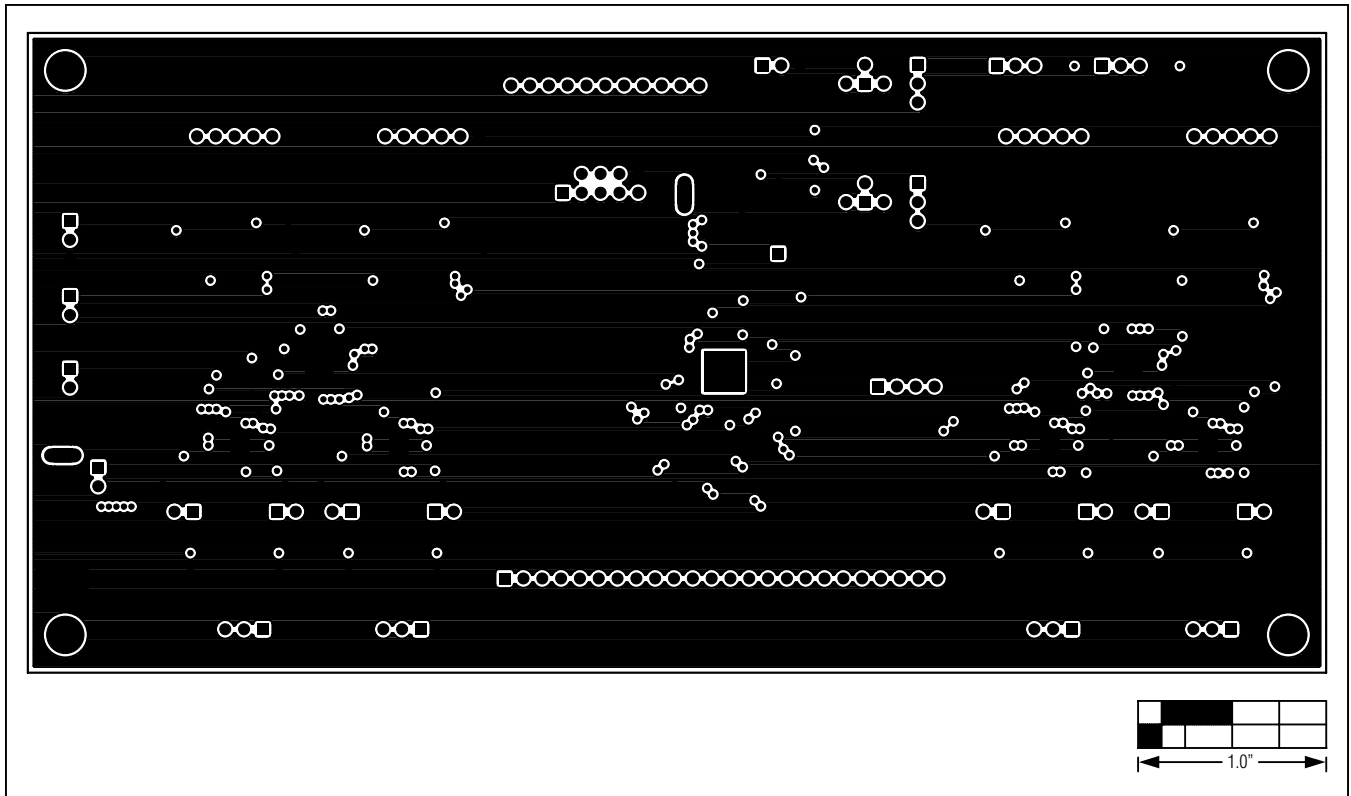

Figure 5. MAX14830 EV Kit PCB Layout—GND Layer 2

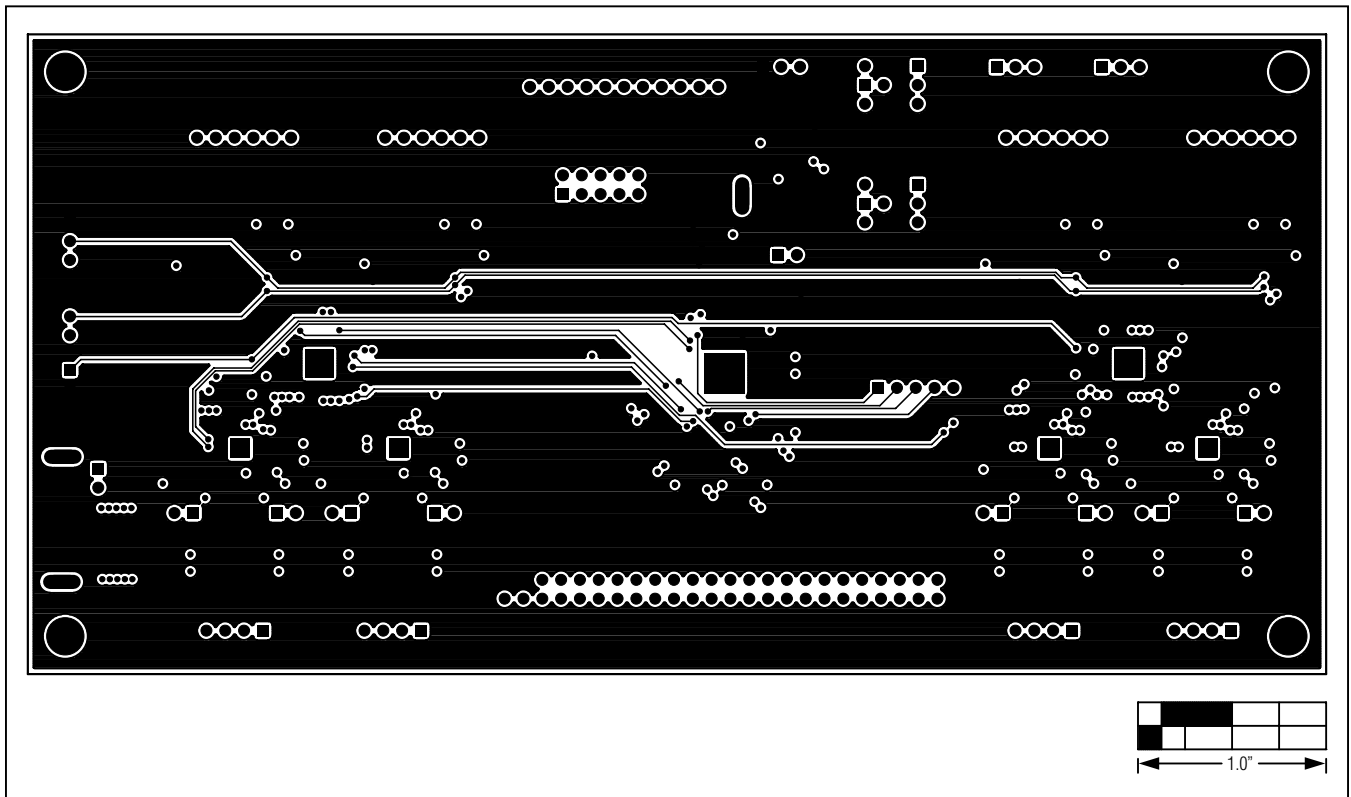

Figure 6. MAX14830 EV Kit PCB Layout—PWR Layer 3

MAX14830 Evaluation Kit

Evaluates: MAX14830

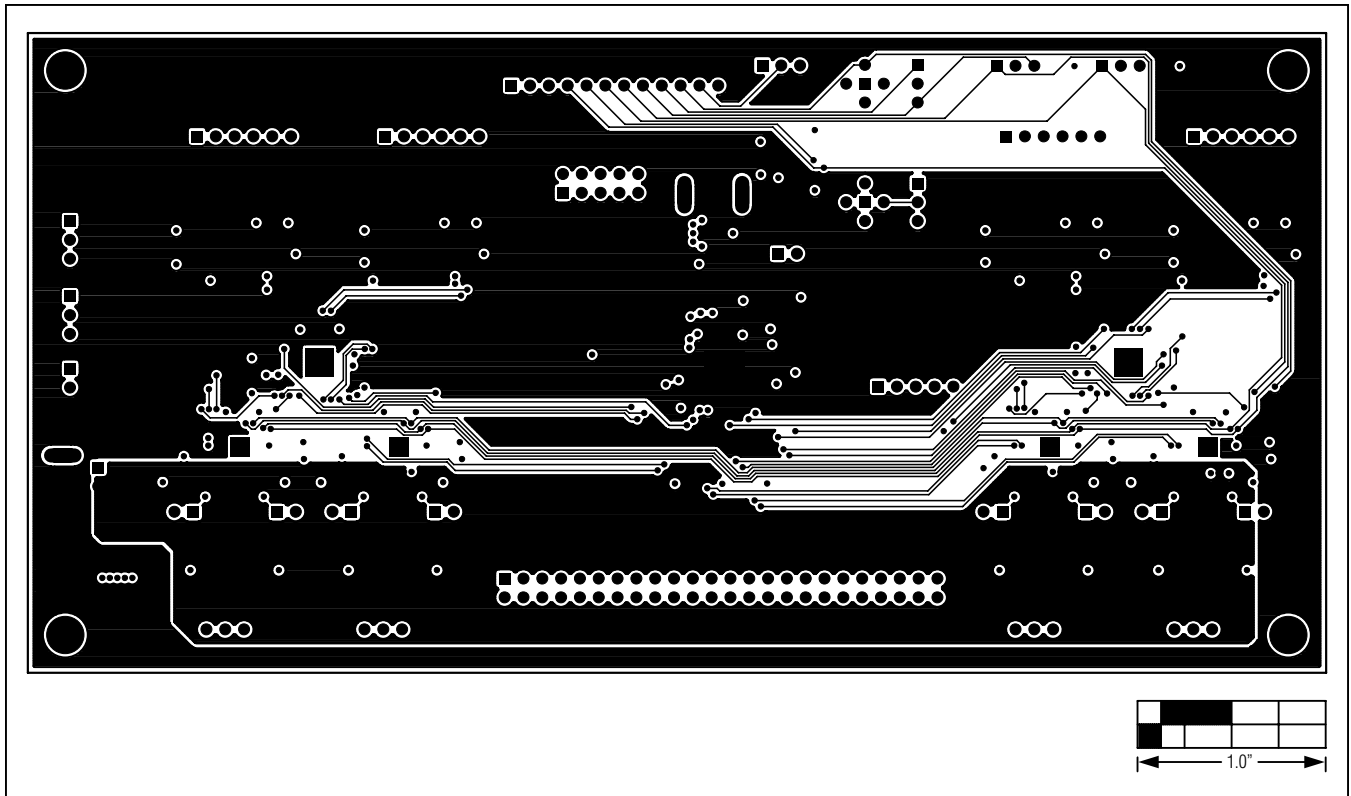

Figure 7. MAX14830 EV Kit PCB Layout—Solder Side

MAX14830 Evaluation Kit

Evaluates: MAX14830

Ordering Information

PART	TYPE
MAX14830EVKIT#	EV Kit

#Denotes RoHS compliant.

MAX14830 Evaluation Kit

Evaluates: MAX14830

Revision History

REVISION NUMBER	REVISION DATE	DESCRIPTION	PAGES CHANGED
0	11/11	Initial release	—
1	7/12	Updated <i>Component List</i> and Figure 2c	1, 2, 9

Maxim cannot assume responsibility for use of any circuitry other than circuitry entirely embodied in a Maxim product. No circuit patent licenses are implied. Maxim reserves the right to change the circuitry and specifications without notice at any time.

Maxim Integrated Products, Inc. 160 Rio Robles, San Jose, CA 95134 USA 1-408-601-1000 _____ 15

Looking for pricing, stock, or lifecycle information?

Click below to explore more details on WIN SOURCE:

- ⊖ [View MAX14830EVKIT# on WIN SOURCE](#)
- ⊖ [Maxim Integrated Information](#)

Optimize Your Supply Chain with WIN SOURCE Solutions

- ✓ Global Sourcing Solution
- ✓ Obsolete Management
- ✓ Cost Control Management
- ✓ Shortage Management
- ✓ Alternative Solution
- ✓ Excess Inventory Management