



**THE DATASHEET OF  
MAX1716EEG+**





# High-Speed, Adjustable, Synchronous Step-Down Controllers with Integrated Voltage Positioning

## General Description

The MAX1716/MAX1854/MAX1855 step-down controllers are intended for core CPU DC-DC converters in notebook computers. They feature a dynamically adjustable output (5-bit DAC), ultra-fast transient response, high DC accuracy, and high efficiency needed for leading-edge CPU core power supplies. Maxim's proprietary Quick-PWM™ quick-response, constant-on-time PWM control scheme handles wide input/output voltage ratios with ease and provides 100ns "instant-on" response to load transients while maintaining a relatively constant switching frequency.

The MAX1716/MAX1854/MAX1855 are designed specifically for CPU core applications requiring a voltage-positioned supply. The voltage-positioning input (VPS), combined with a high DC accuracy control loop, is used to implement a power supply that modifies its output set point in response to the load current. This arrangement decreases full-load power dissipation and reduces the required number of output capacitors.

The 28V input range of the MAX1716/MAX1854/MAX1855 enables single-stage buck conversion from high-voltage batteries for the maximum possible efficiency. Alternatively, the devices' high-frequency capability combined with two-stage conversion (stepping down the +5V system supply instead of the battery) allows the smallest possible physical size. The output voltage can be dynamically adjusted through the 5-bit digital-to-analog converter (DAC) inputs.

The MAX1716/MAX1854/MAX1855 are available in a 24-pin QSOP package. For applications requiring SpeedStep™ power control (see the MAX1717).

## Applications

- Notebook Computers
- Docking Stations
- CPU Core Supply
- Single-Stage (BATT to V<sub>CORE</sub>) Converters
- Two-Stage (+5V to V<sub>CORE</sub>) Converters

## Ordering Information

PART	TEMP. RANGE	PIN-PACKAGE
MAX1716EEG	-40°C to +85°C	24 QSOP
MAX1854EEG	-40°C to +85°C	24 QSOP
MAX1855EEG	-40°C to +85°C	24 QSOP

Quick-PWM is a trademark of Maxim Integrated Products.

SpeedStep is a trademark of Intel Corp.



## Features

- ◆ High-Efficiency Voltage Positioning
- ◆ Quick-PWM Architecture
- ◆ ±1% V<sub>OUT</sub> Line-Regulation Accuracy
- ◆ Adjustable Output Range (5-Bit DAC)
  - MAX1716: 0.925V to 1.6V
  - MAX1854: 0.925V to 2.0V
  - MAX1855: 0.600V to 1.75V
- ◆ 2V to 28V Input Range
- ◆ 200/300/400/550kHz Switching Frequency
- ◆ Output Undervoltage Protection
- ◆ Overvoltage Protection (MAX1716/MAX1855)
- ◆ Drive Large Synchronous-Rectifier MOSFETs
- ◆ 1.7ms Digital Soft-Start
- ◆ 700μA I<sub>CC</sub> Supply Current
- ◆ 1μA Shutdown Supply Current
- ◆ 2V ±1% Reference Output
- ◆ V<sub>GATE</sub> Transition-Complete Indicator
- ◆ Small 24-Pin QSOP Package

## Typical Operating Circuit

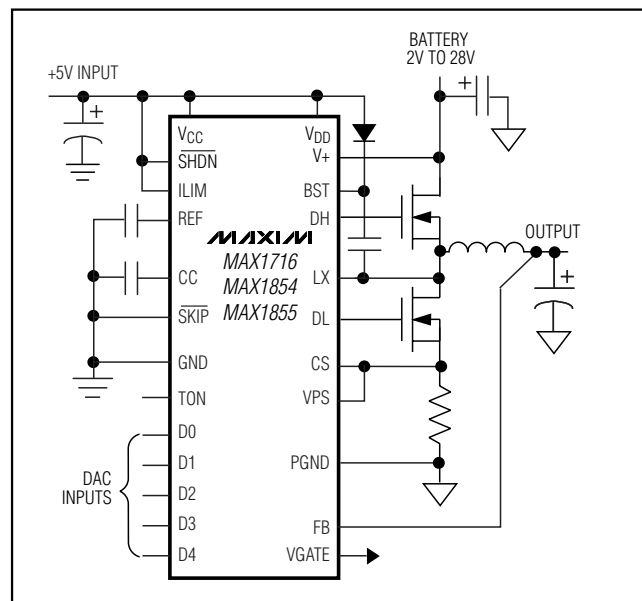

Pin Configuration appears at end of data sheet.

MAX1716/MAX1854/MAX1855

# High-Speed, Adjustable, Synchronous Step-Down Controllers with Integrated Voltage Positioning

## ABSOLUTE MAXIMUM RATINGS

V+ to GND .....	-0.3V to +30V
V <sub>CC</sub> , V <sub>DD</sub> to GND .....	-0.3V to +6V
PGND to GND .....	±0.3V
SHDN, VGATE to GND .....	-0.3V to +6V
ILIM, FB, CC, REF, D0–D4, VPS, TON to GND .....	-0.3V to (V <sub>CC</sub> + 0.3V)
SKIP to GND (Note 1) .....	-0.3V to (V <sub>CC</sub> + 0.3V)
DL to PGND .....	-0.3V to (V <sub>DD</sub> + 0.3V)
BST to GND .....	-0.3V to +36V
DH to LX .....	-0.3V to (V <sub>BST</sub> + 0.3V)

LX to BST .....	-6V to +0.3V
CS to GND .....	-2V to +30V
REF Short Circuit to GND .....	Continuous
Continuous Power Dissipation (T <sub>A</sub> = +70°C)	
24-Pin QSOP (derate 9.5mW/°C above +70°C) .....	762mW
Operating Temperature Range .....	-40°C to +85°C
Junction Temperature .....	+150°C
Storage Temperature Range .....	-65°C to +150°C
Lead Temperature (soldering, 10s) .....	+300°C

**Note 1:** SKIP may be forced below -0.3V, temporarily exceeding the absolute maximum rating, for the purpose of debugging prototype breadboards, using the no-fault test mode. Limit the current drawn to -2mA (max).

Stresses beyond those listed under "Absolute Maximum Ratings" may cause permanent damage to the device. These are stress ratings only, and functional operation of the device at these or any other conditions beyond those indicated in the operational sections of the specifications is not implied. Exposure to absolute maximum rating conditions for extended periods may affect device reliability.

## ELECTRICAL CHARACTERISTICS

(Circuit of Figure 1, V+ = +15V, V<sub>CC</sub> = V<sub>DD</sub> = 5V, SKIP = V<sub>CC</sub>, VPS = PGND, T<sub>A</sub> = 0°C to +85°C, unless otherwise noted. Typical values are at T<sub>A</sub> = +25°C.)

PARAMETER	SYMBOL	CONDITIONS	MIN	TYP	MAX	UNITS	
<b>PWM CONTROLLER</b>							
Input Voltage Range		Battery voltage, V+	2		28	V	
		V <sub>CC</sub> , V <sub>DD</sub>	4.5		5.5		
DC Output Voltage Accuracy (Notes 2, 3)		V+ = 4.5V to 28V, VPS = PGND	DAC codes from 1.35V to 2.0V	-1		1	%
			DAC codes from 0.925V to 1.3V	-1.2		1.2	
			DAC codes from 0.6V to 0.9V	-1.5		1.5	
FB Input Bias Current	I <sub>FB</sub>	FB = 0.6V to 2.0V	-0.2		0.2	μA	
VPS Input Bias Current	I <sub>VPS</sub>	V <sub>VPS</sub> = ±40mV	-1		1	μA	
VPS Gain	A <sub>VPS</sub>	V <sub>VPS</sub> = 0 or -40mV, gain from VPS to FB	0.153	0.175	0.197	%/mV	
CS Input Bias Current	I <sub>CS</sub>	0 to 28V	-1		1	μA	
ILIM Input Leakage Current	I <sub>ILIM</sub>	V <sub>ILIM</sub> = 0 or 5.0V		0.01	100	nA	
Soft-Start Ramp Time		0 to full ILIM		1.7		ms	
On-Time (Note 4)	t <sub>ON</sub>	V+ = 11.0V, V <sub>FB</sub> = 1.5V	TON = GND	205	255	300	ns
			TON = REF	280	327	375	
			TON = open	425	470	520	
			TON = V <sub>CC</sub>	615	678	740	
Minimum Off-Time (Note 4)	t <sub>OFF(MIN)</sub>			400	500	ns	

# High-Speed, Adjustable, Synchronous Step-Down Controllers with Integrated Voltage Positioning

## ELECTRICAL CHARACTERISTICS (continued)

(Circuit of Figure 1,  $V_+ = +15V$ ,  $V_{CC} = V_{DD} = 5V$ ,  $\overline{SKIP} = V_{CC}$ ,  $VPS = PGND$ ,  $T_A = 0^\circ C$  to  $+85^\circ C$ , unless otherwise noted. Typical values are at  $T_A = +25^\circ C$ .)

PARAMETER	SYMBOL	CONDITIONS	MIN	TYP	MAX	UNITS	
<b>BIAS AND REFERENCE</b>							
Quiescent Supply Current ( $V_{CC}$ )	$I_{CC}$	Measured at $V_{CC}$ , FB forced above the regulation point		700	950	$\mu A$	
Quiescent Supply Current ( $V_{DD}$ )	$I_{DD}$	Measured at $V_{DD}$ , FB forced above the regulation point		<1	5	$\mu A$	
Quiescent Supply Current ( $V_+$ )	$I_+$			25	40	$\mu A$	
Shutdown Supply Current ( $V_{CC}$ )		$\overline{SHDN} = GND$		<1	5	$\mu A$	
Shutdown Supply Current ( $V_{DD}$ )		$\overline{SHDN} = GND$		<1	5	$\mu A$	
Shutdown Supply Current ( $V_+$ )		$\overline{SHDN} = GND$ , $V_{CC} = V_{DD} = 0$ or $5V$		<1	5	$\mu A$	
Reference Voltage	$V_{REF}$	$V_{CC} = 4.5V$ to $5.5V$ , no external REF load	1.98	2	2.02	V	
Reference Load Regulation		$I_{REF} = 0$ to $50\mu A$			0.01	V	
REF Sink Current	$I_{REF}$	REF in regulation	10			$\mu A$	
REF Fault Lockout Voltage		Falling edge		1.6		V	
<b>FAULT PROTECTION</b>							
Output Overvoltage Fault Threshold (Note 5)		Measured at FB	MAX1716	1.8	1.9	2.0	V
			MAX1855	1.97	2.0	2.03	
Output Overvoltage Fault Propagation Delay (Note 5)		FB forced to 2% above trip threshold (MAX1716/MAX1855 only)		1.5		$\mu s$	
Output Undervoltage Fault Threshold (Foldback)			35	40	45	%	
Output Undervoltage Fault Propagation Delay		FB forced to 2% below trip threshold		10		$\mu s$	
Output Undervoltage Fault Blanking Time (Foldback)		From $\overline{SHDN}$ signal going high	10		30	ms	
Current-Limit Threshold (Positive, Default)	$V_{ITH}$	$V_{PGND} - V_{CS}$ , $I_{LIM} = V_{CC}$	110	120	130	mV	
Current-Limit Threshold (Positive, Adjustable)	$V_{ITH}$	$V_{PGND} - V_{CS}$	$V_{ILIM} = 0.5V$	40	50	60	mV
			$V_{ILIM} = 2V$ (REF)	170	200	230	
Negative Current-Limit Threshold		$V_{PGND} - V_{CS}$		$-1.2 \times V_{ITH}$		mV	
Zero-Crossing Current-Limit Threshold		$V_{PGND} - V_{CS}$		3		mV	
Thermal Shutdown Threshold		Hysteresis = $10^\circ C$		150		$^\circ C$	
$V_{CC}$ Undervoltage Lockout Threshold		Rising edge, hysteresis = $20mV$ , switching disabled below this level	4.0		4.45	V	

MAX1716/MAX1854/MAX1855

# High-Speed, Adjustable, Synchronous Step-Down Controllers with Integrated Voltage Positioning

## ELECTRICAL CHARACTERISTICS (continued)

(Circuit of Figure 1,  $V_+ = +15V$ ,  $V_{CC} = V_{DD} = 5V$ ,  $\overline{SKIP} = V_{CC}$ ,  $V_{PS} = PGND$ ,  $T_A = 0^\circ C$  to  $+85^\circ C$ , unless otherwise noted. Typical values are at  $T_A = +25^\circ C$ .)

PARAMETER	SYMBOL	CONDITIONS	MIN	TYP	MAX	UNITS
VGATE Lower Trip Threshold		Measured at FB with respect to unloaded output voltage, falling edge	-12.5	-10	-7.5	%
VGATE Upper Trip Threshold		Measured at FB with respect to unloaded output voltage, rising edge	7.5	10	12.5	%
VGATE Propagation Delay		Falling edge, FB forced 2% below or above VGATE trip threshold		1.5		$\mu s$
VGATE Output Low Voltage		$I_{SINK} = 1mA$			0.4	V
VGATE Leakage Current		High state, forced to 5.5V			1	$\mu A$
<b>GATE DRIVERS</b>						
DH Gate Driver On-Resistance	$R_{ON(DH)}$	$V_{BST} - V_{LX}$ forced to 5V		1.3	5	$\Omega$
DL Gate Driver On-Resistance	$R_{ON(DL)}$	High state (pullup)		1.5	5	$\Omega$
		Low state (pulldown)		0.5	1.7	
DH Gate Driver Source/Sink Current	$I_{DH}$	DH forced to 2.5V, $V_{BST} - V_{LX}$ forced to 5V		1		A
DL Gate Drive Sink Current	$I_{DL}$	DL forced to 5V		3		A
DL Gate Driver Source Current	$I_{DL}$	DL forced to 2.5V		1		A
Dead-Time		DL rising		35		ns
		DH rising		26		
<b>LOGIC AND I/O</b>						
Logic Input High Voltage	$V_{IH}$	D0–D4, $\overline{SHDN}$ , $\overline{SKIP}$	2.4			V
Logic Input Low Voltage	$V_{IL}$	D0–D4, $\overline{SHDN}$ , $\overline{SKIP}$			0.8	V
TON Input Levels		TON = $V_{CC}$ (200kHz operation)	$V_{CC} - 0.4$			V
		TON = open (300kHz operation)	3.15	3.85		
		TON = REF (400kHz operation)	1.65	2.35		
		TON = GND (550kHz operation)		0.5		
Logic Input Current		TON = GND or $V_{CC}$	-3	3		$\mu A$
		$\overline{SHDN}$ , $\overline{SKIP}$ = GND or $V_{CC}$	-1	1		
D0–D4 Pullup Current		D0–D4 = GND	3	5	10	$\mu A$
$\overline{SKIP}$ No-Fault Mode Current		$T_A = +25^\circ C$	-1.5		-0.1	mA

# High-Speed, Adjustable, Synchronous Step-Down Controllers with Integrated Voltage Positioning

MAX1716/MAX1854/MAX1855

## ELECTRICAL CHARACTERISTICS

(Circuit of Figure 1,  $V_+ = +15V$ ,  $V_{CC} = V_{DD} = 5V$ ,  $\overline{SKIP} = V_{CC}$ ,  $VPS = PGND$ ,  $T_A = -40^\circ C$  to  $+85^\circ C$ , unless otherwise noted.) (Note 6)

PARAMETER	SYMBOL	CONDITIONS		MIN	TYP	MAX	UNITS
<b>PWM CONTROLLER</b>							
Input Voltage Range		Battery voltage, $V_+$		2		28	V
		$V_{CC}$ , $V_{DD}$		4.5		5.5	
DC Output Voltage Accuracy (Notes 2, 3)		$V_+ = 4.5V$ to $28V$ , $VPS = PGND$	DAC codes from 1.35V to 2.0V	-1.6		1.6	%
			DAC codes from 0.6V to 1.3V	-2		2	
FB Input Bias Current	$I_{FB}$	$FB = 0.6V$ to $2.0V$		-0.2		0.2	$\mu A$
VPS Input Bias Current	$I_{VPS}$	$V_{VPS} = \pm 40mV$		-1		1	$\mu A$
VPS Gain	$A_{VPS}$	$V_{VPS} = 0$ or $-40mV$ , gain from VPS to FB		0.153		0.197	%/mV
CS Input Bias Current	$I_{CS}$	0 to 28V		-1		1	$\mu A$
ILIM Input Leakage Current	$I_{LIM}$	$V_{LIM} = 0$ or $5.0V$				100	nA
On-Time (Note 4)	$t_{ON}$	$V_+ = 11.0V$ , $V_{FB} = 1.5V$	TON = GND	205		300	ns
			TON = REF	280		375	
			TON = open	425		520	
			TON = $V_{CC}$	615		740	
Minimum Off-Time (Note 4)	$t_{OFF(MIN)}$					500	ns
<b>BIAS AND REFERENCE</b>							
Quiescent Supply Current ( $V_{CC}$ )	$I_{CC}$	Measured at $V_{CC}$ , FB forced above the regulation point				950	$\mu A$
Quiescent Supply Current ( $V_{DD}$ )	$I_{DD}$	Measured at $V_{DD}$ , FB forced above the regulation point				5	$\mu A$
Quiescent Supply Current ( $V_+$ )	$I_+$					40	$\mu A$
Shutdown Supply Current ( $V_{CC}$ )		$\overline{SHDN} = GND$				5	$\mu A$
Shutdown Supply Current ( $V_{DD}$ )		$\overline{SHDN} = GND$				5	$\mu A$
Shutdown Supply Current ( $V_+$ )		$\overline{SHDN} = GND$ , $V_+ = 28V$ , $V_{CC} = V_{DD} = 0$ or $5V$				5	$\mu A$
Reference Voltage	$V_{REF}$	$V_{CC} = 4.5V$ to $5.5V$ , no external REF load		1.98		2.02	V
Reference Load Regulation		$I_{REF} = 0$ to $50\mu A$				0.01	V
REF Sink Current	$I_{REF}$	REF in regulation		10			$\mu A$
<b>FAULT PROTECTION</b>							
Output Overvoltage Fault Threshold (Note 5)		Measured at FB	MAX1716	1.8		2.0	V
			MAX1855	1.97		2.03	
Output Undervoltage Fault Threshold (Foldback)				35		45	%
Output Undervoltage Fault Blanking Time (Foldback)		From $\overline{SHDN}$ signal going high		10		30	ms

# High-Speed, Adjustable, Synchronous Step-Down Controllers with Integrated Voltage Positioning

## ELECTRICAL CHARACTERISTICS (continued)

(Circuit of Figure 1,  $V_+ = +15V$ ,  $V_{CC} = V_{DD} = 5V$ ,  $\overline{SKIP} = V_{CC}$ ,  $V_{PS} = PGND$ ,  $T_A = -40^\circ C$  to  $+85^\circ C$ , unless otherwise noted.) (Note 6)

PARAMETER	SYMBOL	CONDITIONS	MIN	TYP	MAX	UNITS
Current-Limit Threshold (Positive, Default)	$V_{I\overline{TH}}$	$V_{PGND} - V_{CS}$ , $I_{LIM} = V_{CC}$	100		140	mV
Current-Limit Threshold (Positive, Adjustable)	$V_{I\overline{TH}}$	$V_{PGND} - V_{CS}$	$V_{ILIM} = 0.5V$	35	65	mV
			$V_{ILIM} = 2V$ (REF)	160	240	
$V_{CC}$ Undervoltage Lockout Threshold		Rising edge, hysteresis = 20mV, switching disabled below this level	4.0		4.45	V
VGATE Lower Trip Threshold		Measured at FB with respect to unloaded output voltage, falling edge	-12.5		-7.5	%
VGATE Upper Trip Threshold		Measured at FB with respect to unloaded output voltage, rising edge	7.5		12.5	%
VGATE Output Low Voltage		$I_{SINK} = 1mA$			0.4	V
VGATE Leakage Current		High state, forced to 5.5V			1	$\mu A$
<b>GATE DRIVERS</b>						
DH Gate Driver On-Resistance	$R_{ON(DH)}$	$V_{BST} - V_{LX}$ forced to 5V			5	$\Omega$
DL Gate Driver On-Resistance	$R_{ON(DL)}$	High state (pullup)			5	$\Omega$
		Low state (pulldown)			1.7	
<b>LOGIC AND I/O</b>						
Logic Input High Voltage	$V_{IH}$	D0–D4, $\overline{SHDN}$ , $\overline{SKIP}$	2.4			V
Logic Input Low Voltage	$V_{IL}$	D0–D4, $\overline{SHDN}$ , $\overline{SKIP}$			0.8	V
TON Input Levels		TON = $V_{CC}$ (200kHz operation)	$V_{CC} - 0.4$			V
		TON = open (300kHz operation)	3.15	3.85		
		TON = REF (400kHz operation)	1.65	2.35		
		TON = GND (550kHz operation)		0.5		
Logic Input Current		TON = GND or $V_{CC}$	-3		3	$\mu A$
		$\overline{SHDN}$ , $\overline{SKIP} = GND$ or $V_{CC}$	-1		1	
D0–D4 Pullup Current		D0–D4 = GND	3		10	$\mu A$

**Note 2:** Output voltage accuracy specifications apply to DAC voltages from 0.6V to 2.0V. Includes load-regulation error.

**Note 3:** When the inductor is in continuous conduction, the output voltage will have a DC regulation level higher than the error-comparator threshold by 50% of the ripple. In discontinuous conduction ( $\overline{SKIP} = GND$ , light load), the output voltage will have a DC regulation level higher than the trip level by approximately 1.5% due to slope compensation.

**Note 4:** On-time and off-time specifications are measured from 50% to 50% at the DH pin, with LX forced to 0, BST forced to 5V, and a 500pF capacitor from DH to LX to simulate external MOSFET gate capacitance. Actual in-circuit times may be different due to MOSFET switching speeds.

**Note 5:** The MAX1854 does not have overvoltage protection.

**Note 6:** Specifications to  $-40^\circ C$  are guaranteed by design, not production tested.

# High-Speed, Adjustable, Synchronous Step-Down Controllers with Integrated Voltage Positioning

## Typical Operating Characteristics

(Circuit from Figure 1, components from Table 2,  $T_A = +25^\circ\text{C}$ , unless otherwise noted.)

MAX1716/MAX1854/MAX1855

### SKIP MODE ( $\overline{\text{SKIP}} = \text{GND}$ )

- A1:  $V_{\text{BATT}} = 4.5\text{V}$
- B1:  $V_{\text{BATT}} = 7\text{V}$
- C1:  $V_{\text{BATT}} = 15\text{V}$
- D1:  $V_{\text{BATT}} = 24\text{V}$

### PWM MODE ( $\overline{\text{SKIP}} = V_{\text{CC}}$ )

- A2:  $V_{\text{BATT}} = 4.5\text{V}$
- B2:  $V_{\text{BATT}} = 7\text{V}$
- C2:  $V_{\text{BATT}} = 15\text{V}$
- D2:  $V_{\text{BATT}} = 24\text{V}$

**EFFICIENCY vs. LOAD CURRENT  
(2.0V AT 300kHz)**

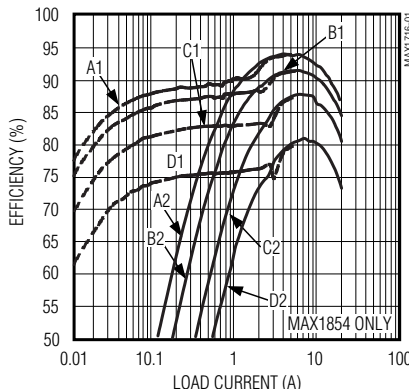

**EFFICIENCY vs. LOAD CURRENT  
(1.6V AT 300kHz)**

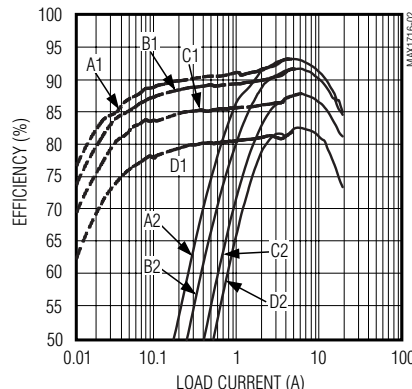

**EFFICIENCY vs.  
LOAD CURRENT (1.3V AT 200kHz)**

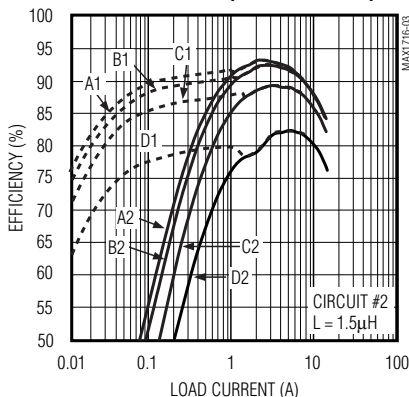

**EFFICIENCY vs.  
LOAD CURRENT (1.3V AT 300kHz)**

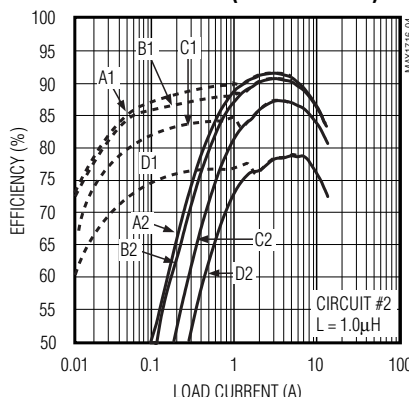

**EFFICIENCY vs.  
LOAD CURRENT (1.3V AT 550kHz)**

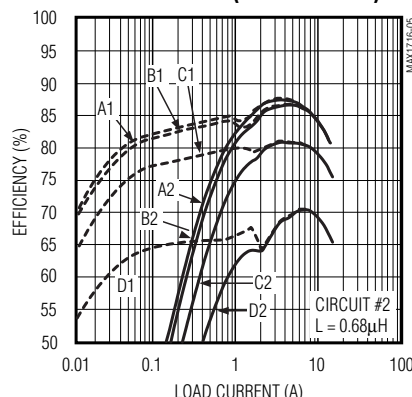

**EFFECTIVE EFFICIENCY vs.  
LOAD CURRENT (1.3V AT 200kHz)**

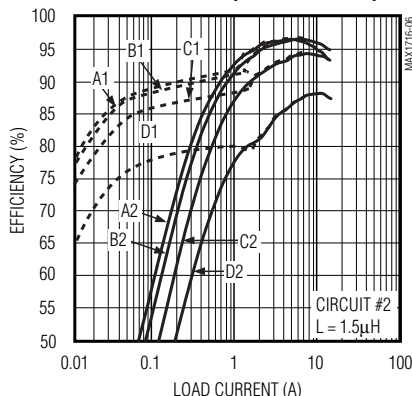

**EFFECTIVE EFFICIENCY vs.  
LOAD CURRENT (1.3V AT 300kHz)**

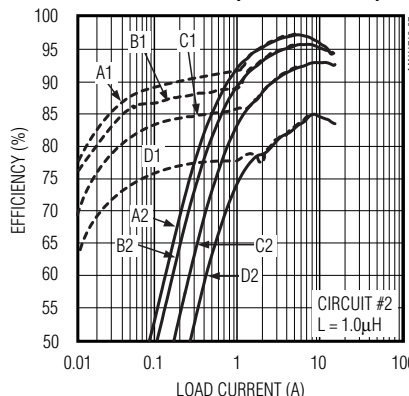

**EFFECTIVE EFFICIENCY vs.  
LOAD CURRENT (1.3V AT 550kHz)**

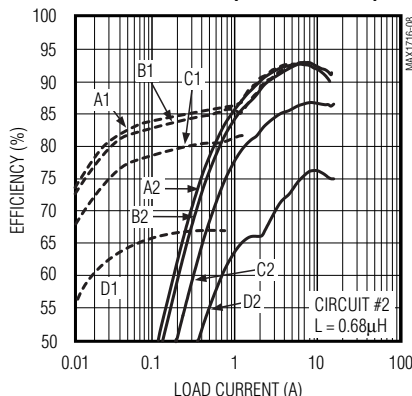

# High-Speed, Adjustable, Synchronous Step-Down Controllers with Integrated Voltage Positioning

## Typical Operating Characteristics (continued)

(Circuit from Figure 1, components from Table 2,  $T_A = +25^\circ\text{C}$ , unless otherwise noted.)

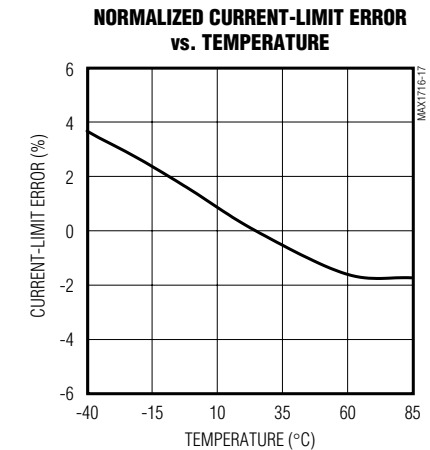
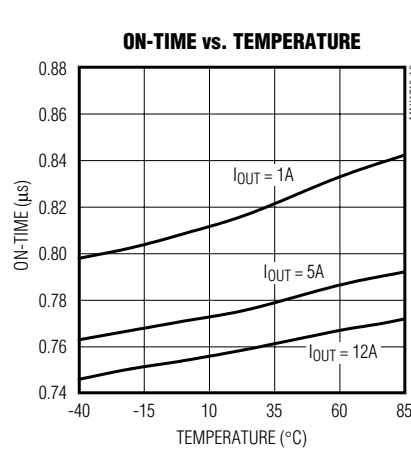
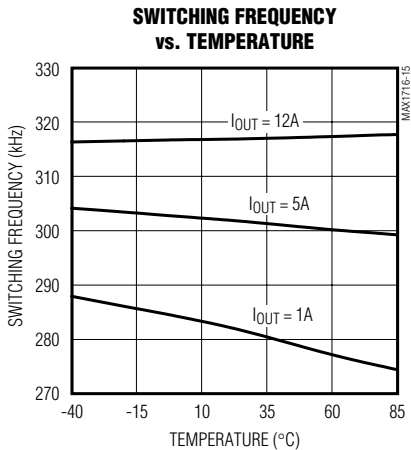
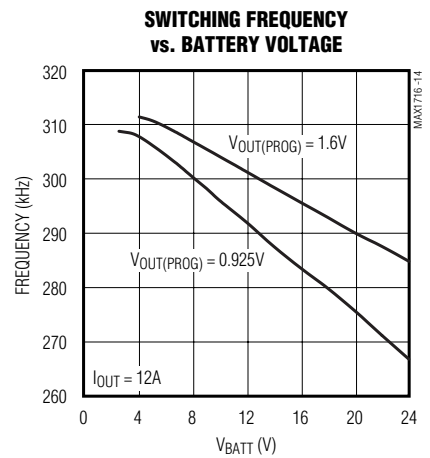
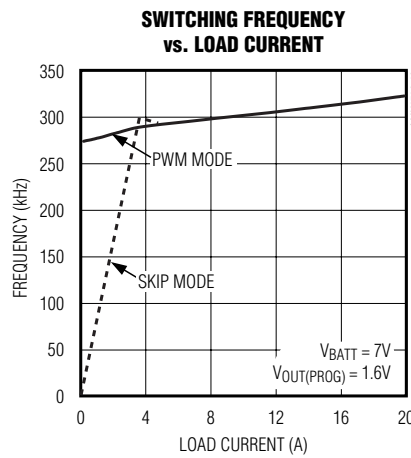
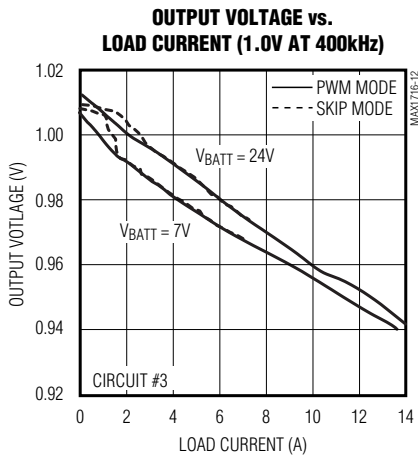
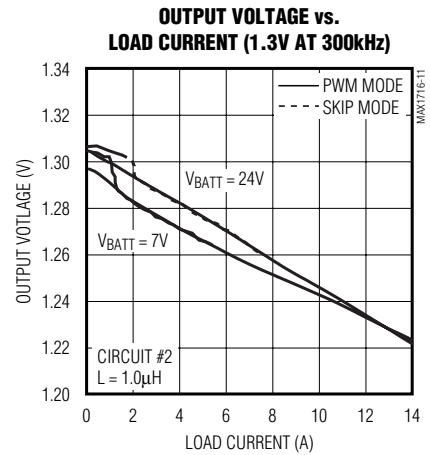
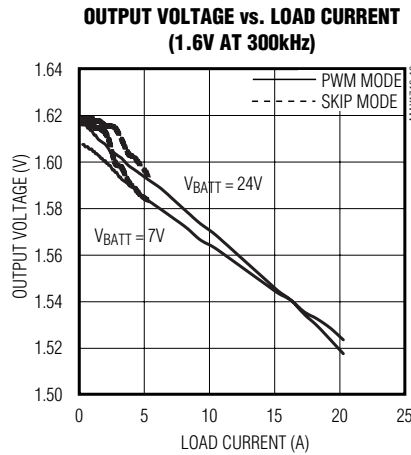
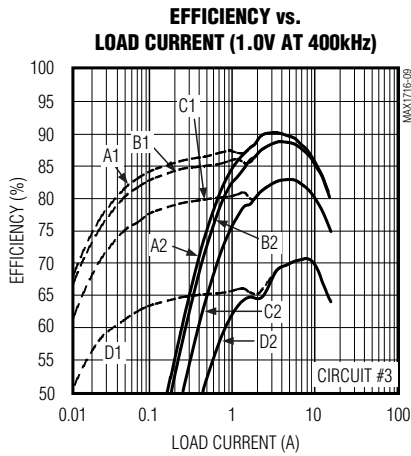

# High-Speed, Adjustable, Synchronous Step-Down Controllers with Integrated Voltage Positioning

## Typical Operating Characteristics (continued)

(Circuit from Figure 1, components from Table 2,  $T_A = +25^\circ\text{C}$ , unless otherwise noted.)

MAX1716/MAX1854/MAX1855

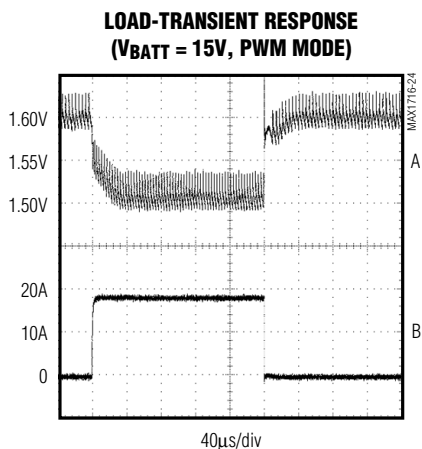
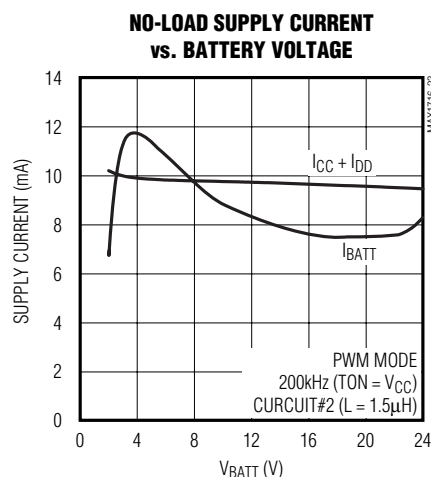
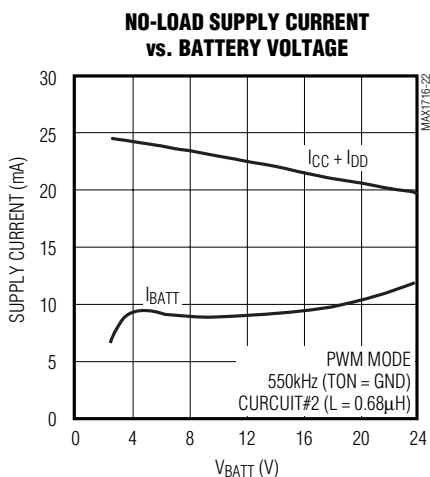
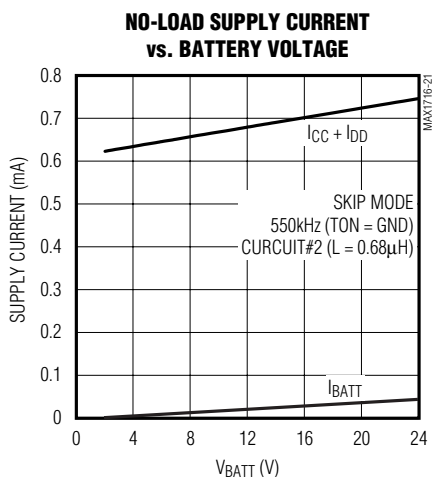
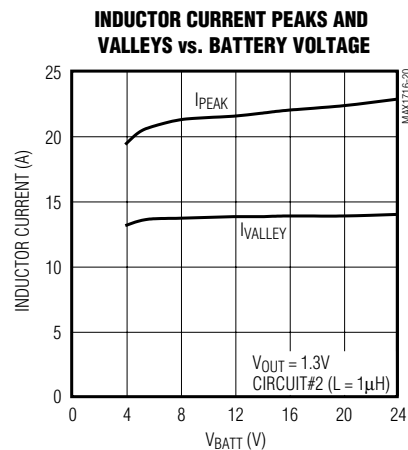
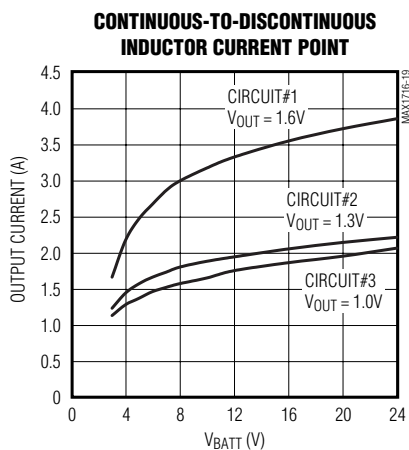
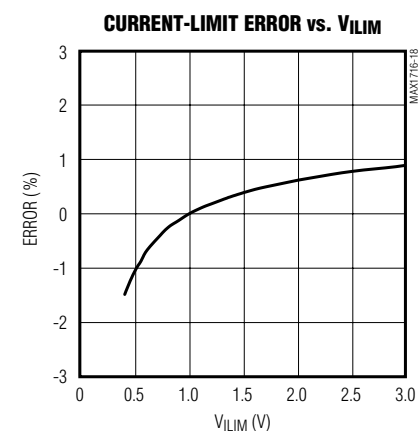

A.  $V_{OUT} = 1.6\text{V}$ , 50mV/div; B.  $I_{OUT} = 1.3\text{A TO } 18\text{A}$ , 10A/div; CIRCUIT #1,  $V_{BATT} = 15\text{V}$ , PWM MODE

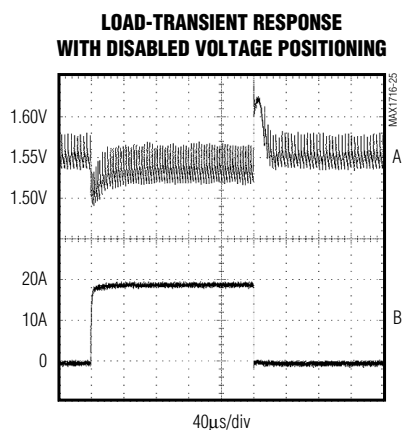

A.  $V_{OUT} = 1.6\text{V}$ , 50mV/div; B.  $I_{OUT} = 0.3\text{A TO } 18\text{A}$ , 10A/div; CIRCUIT #1,  $V_{BATT} = 15\text{V}$ , PWM MODE; VPS = PGND

# High-Speed, Adjustable, Synchronous Step-Down Controllers with Integrated Voltage Positioning

## Typical Operating Characteristics (continued)

(Circuit from Figure 1, components from Table 2,  $T_A = +25^\circ\text{C}$ , unless otherwise noted.)

**LOAD-TRANSIENT RESPONSE**  
( $V_{BATT} = 15\text{V}$ , SKIP MODE)

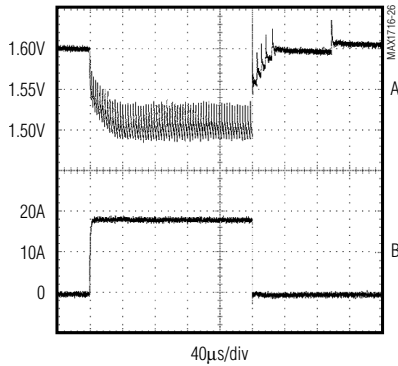

A.  $V_{OUT} = 1.6\text{V}$ , 50mV/div; B.  $I_{OUT} = 0.3\text{A TO } 18\text{A}$ , 10A/div  
CIRCUIT #1,  $V_{BATT} = 15\text{V}$ , SKIP MODE

**LOAD-TRANSIENT RESPONSE**  
( $V_{BATT} = 4.5\text{V}$ )

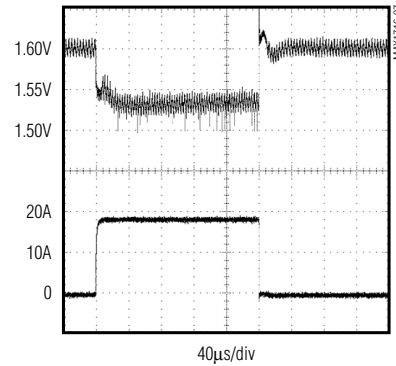

A.  $V_{OUT} = 1.6\text{V}$ , 50mV/div  
B.  $I_{OUT} = 0.3\text{A TO } 18\text{A}$ , 10A/div  
CIRCUIT #1,  $V_{BATT} = 4.5\text{V}$ , PWM MODE

**LOAD-TRANSIENT RESPONSE**  
( $V_{OUT(Prog)} = 1.0\text{V}$ )

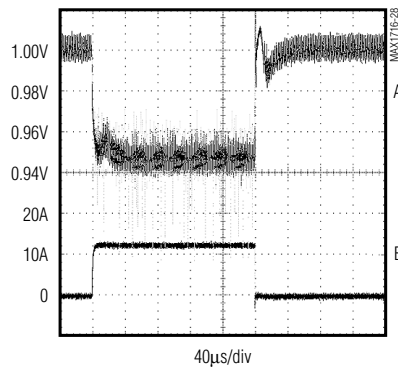

A.  $V_{OUT} = 1.0\text{V}$ , 20mV/div  
B.  $I_{OUT} = 0.3\text{A TO } 12\text{A}$ , 10A/div  
CIRCUIT #3,  $V_{BATT} = 4.5\text{V}$ , PWM MODE

**LOAD-TRANSIENT RESPONSE**  
WITH CERAMIC OUTPUT CAPACITORS

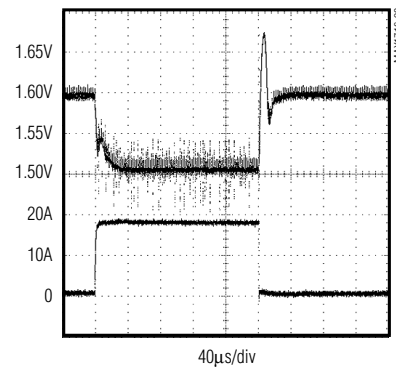

A.  $V_{OUT} = 1.6\text{V}$ , 50mV/div  
B.  $I_{OUT} = 0.3\text{A TO } 18\text{A}$ , 10A/div  
CIRCUIT #4,  $V_{BATT} = 15\text{V}$ , PWM MODE

# High-Speed, Adjustable, Synchronous Step-Down Controllers with Integrated Voltage Positioning

## Typical Operating Characteristics (continued)

(Circuit from Figure 1, components from Table 2,  $T_A = +25^\circ\text{C}$ , unless otherwise noted.)

MAX1716/MAX1854/MAX1855

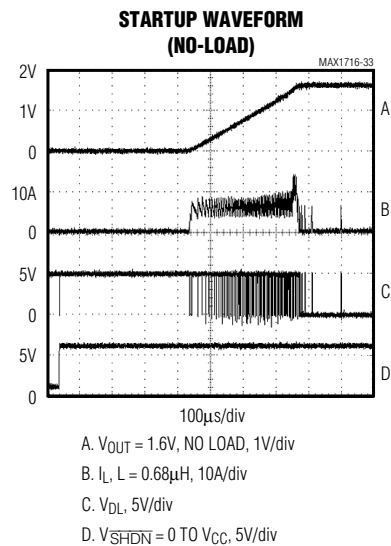
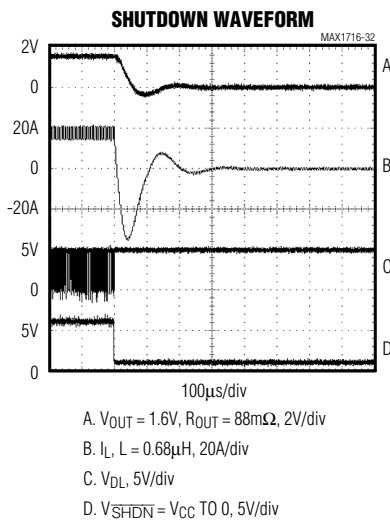
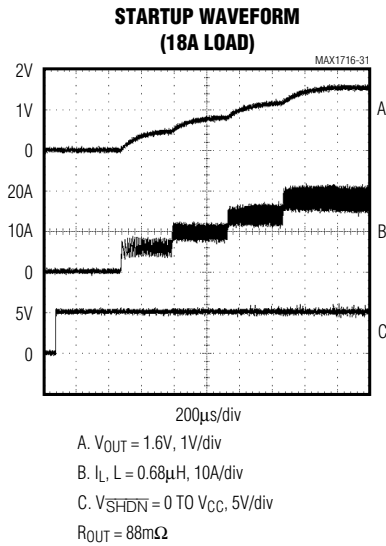
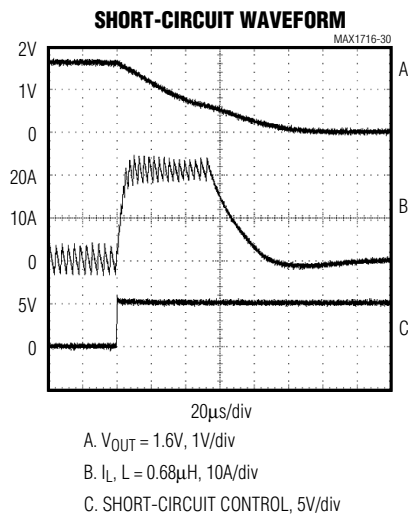

# High-Speed, Adjustable, Synchronous Step-Down Controllers with Integrated Voltage Positioning

## Pin Description

PIN	NAME	FUNCTION
1	DH	High-Side Gate Driver Output. DH swings from LX to BST.
2	V+	Battery Voltage Sense Connection. Connect V+ to input power source. V+ is used only for PWM one-shot timing. DH on-time is inversely proportional to input voltage over a 2V to 28V range.
3	$\overline{\text{SHDN}}$	Shutdown Control Input. Drive $\overline{\text{SHDN}}$ to GND to force the MAX1716/MAX1854/MAX1855 into shutdown. Drive or connect to V <sub>CC</sub> for normal operation. A rising edge on $\overline{\text{SHDN}}$ clears the fault latch.
4	FB	Feedback Input. Normally connected to V <sub>OUT</sub> . FB is connected to the bulk output filter capacitors locally at the power supply. An external resistive divider can optionally set the output voltage.
5	CC	Voltage-Positioning Compensation Capacitor. Connect a 47pF to 1000pF (47pF typ) capacitor from CC to GND to adjust the loop's response time.
6	ILIM	Current-Limit Adjustment. The GND-CS current-limit threshold defaults to 120mV, if ILIM is tied to V <sub>CC</sub> . In adjustable mode, the current-limit threshold voltage is 1/10th the voltage seen at ILIM over a 0.5V to 2.0V range. The logic threshold for switchover to the 120mV default value is approximately V <sub>CC</sub> - 1V. Connect ILIM to REF for a fixed 200mV threshold.
7	V <sub>CC</sub>	Analog Supply Input for PWM Core. Connect to the system supply voltage (+4.5V to +5.5V) with a series 20 $\Omega$ resistor. Bypass to GND with a 0.22 $\mu$ F (min) ceramic capacitor.
8	TON	On-Time Selection-Control Input. This is a four-level input used to determine DH on-time. Connect to GND, REF, or V <sub>CC</sub> , or leave TON unconnected to set the following switching frequencies: GND = 550kHz, REF = 400kHz, floating = 300kHz, and V <sub>CC</sub> = 200kHz.
9	REF	+2.0V Reference Voltage Output. Bypass to GND with 0.22 $\mu$ F (min) capacitor. Can supply 50 $\mu$ A for external loads.
10	GND	Analog Ground
11	VPS	Voltage-Positioning Sense Input. Connect to CS through a 1k $\Omega$ resistor to maximize the load-dependent output voltage drop, or adjust the voltage positioning level by connecting a resistive divider from CS to PGND. Refer to <i>Setting Voltage Positioning</i> on how to select resistor values.
12	VGATE	Open-Drain Power-Good Output. VGATE is normally high when the output is in regulation. VGATE is low in shutdown, undervoltage lockout, and during soft-start. Any fault condition forces VGATE low, and it remains low until the fault is cleared.
13	DL	Low-Side Gate-Driver Output. DL swings from PGND to V <sub>DD</sub> .
14	PGND	Power Ground
15	V <sub>DD</sub>	Supply Input for the DL Gate Drive. Connect to the system supply voltage, +4.5V to +5.5V. Bypass to PGND with a 1 $\mu$ F (min) ceramic capacitor.
16	D4	MSB DAC Code Input. 5 $\mu$ A internal pullup to V <sub>CC</sub> (Table 5).
17	D3	DAC Code Input. 5 $\mu$ A internal pullup to V <sub>CC</sub> (Table 5).
18	D2	DAC Code Input. 5 $\mu$ A internal pullup to V <sub>CC</sub> (Table 5).
19	D1	DAC Code Input. 5 $\mu$ A internal pullup to V <sub>CC</sub> (Table 5).
20	D0	LSB DAC Code Input. 5 $\mu$ A internal pullup to V <sub>CC</sub> (Table 5).

# High-Speed, Adjustable, Synchronous Step-Down Controllers with Integrated Voltage Positioning

## Pin Description (continued)

PIN	NAME	FUNCTION
21	SKIP	Pulse-Skipping or Low-Noise Mode Control Input. Connect to V <sub>CC</sub> for low-noise forced-PWM mode. Connect to GND to enable pulse-skipping operation. Low-noise forced-PWM mode causes inductor current recirculation at light loads and suppresses pulse-skipping operation. Normal operation prevents current recirculation. SKIP can also be used to disable both overvoltage and undervoltage protection circuits and clear the fault latch (see <i>No-Fault Test Mode</i> ). <b>Do not leave SKIP floating.</b>
22	BST	Boost Flying-Capacitor Connection. Connect to an external capacitor and diode according to the standard application circuit (Figure 1).
23	LX	External Inductor Connection. Connect LX to the switched side of the inductor. LX serves as the lower supply rail for the DH high-side gate driver. LX does not connect to the current-limit comparator.
24	CS	Current-Sense Input. Connect a resistor (R <sub>SENSE</sub> ) between CS and PGND. The current-limit threshold is set by ILIM. If the current-sense signal (Inductor Current × R <sub>SENSE</sub> ) exceeds the current-limit threshold, the MAX1716/MAX1854/MAX1855 will not initiate a new cycle.

**Table 1. Component Selection for Standard Applications**

COMPONENT	CIRCUIT 1 (FIGURE 1)	CIRCUIT 2 (FIGURE 11)	CIRCUIT 3 (FIGURE 12)	CIRCUIT 4 (FIGURE 13)
Output Voltage	1.6V	1.3V	1.0V	1.6V
Input Voltage Range	7V to 24V	7V to 24V	7V to 24V	7V to 24V
Maximum Load Current	18A	12A	12A	18A
Inductor	0.68μH Sumida CDEP134H-0R6 or Panasonic ETQP6F0R6BFA	1μH Sumida CEP125-1R0MC or Panasonic ETQP6FIRIBFA	0.68μH Sumida CDEP134H-0R6 or Panasonic ETQP6F0R6BFA	0.47μH Sumitomo CXE-R47
TON Level	Float	Float	REF	GND
Frequency	300kHz	300kHz	400kHz	550kHz
High-Side MOSFET	International Rectifier (2) IRF7811	International Rectifier IRF7811	International Rectifier IRF7811	International Rectifier (2) IRF7811
Low-Side MOSFET	Fairchild (2) FDS7764A Or International Rectifier (2) IRF7811	Fairchild (2) FDS7764A Or International Rectifier (2) IRF7811	Fairchild (2) FDS7764A Or International Rectifier (2) IRF7811	Fairchild (2) FDS7764A Or International Rectifier (2) IRF7811
Input Capacitor	(5) 10μF Taiyo Yuden TMK432BJ106	(4) 10μF Taiyo Yuden TMK432BJ106	(4) 10μF Taiyo Yuden TMK432BJ106	(5) 10μF Taiyo Yuden TMK432BJ106
Output Capacitor	(5) 220μF Panasonic EEFUE0E221R	(4) 220μF Panasonic EEFUE0E221R	(4) 220μF Panasonic EEFUE0E221R	(8) 47μF Taiyo Yuden JMK432BJ476MM or TDK C4532X5ROJ476M
Current-Sense Resistor	3mΩ	3.5mΩ	3.5mΩ	3mΩ
ILIM Level	V <sub>REF</sub> /3	V <sub>REF</sub> /4	V <sub>REF</sub> /4	V <sub>REF</sub> /3
Voltage-Positioning Resistor Ratio	1:1 (0.5x)	1:2 (0.66x)	1:2 (0.66x)	1:1 (0.5x)

# High-Speed, Adjustable, Synchronous Step-Down Controllers with Integrated Voltage Positioning

Table 2. Component Suppliers

MANUFACTURER	PHONE (COUNTRY CODE)	WEBSITE
<b>MOSFETs</b>		
Fairchild Semiconductor	(1) 888-522-5372	www.fairchildsemi.com
International Rectifier	(1) 310-322-3331	www.irf.com
Siliconix	(1) 203-268-6261	www.vishay.com
<b>CAPACITORS</b>		
Kemet	(1) 408-986-0424	www.kemet.com
Panasonic	(1) 847-468-5624	www.panasonic.com
Sanyo	(65) 281-3226 (Singapore) (1) 408-749-9714	www.secc.co.jp
Taiyo Yuden	(03) 3667-3408 (Japan) (1) 408-573-4150	www.t-yuden.com
TDK	(1) 847-390-4373	www.tdk.com
<b>INDUCTORS</b>		
Coilcraft	(1) 800-322-2645	www.coilcraft.com
Coiltronics	(1) 561-752-5000	www.coiltronics.com
Sumida	(1) 408-982-9660	www.sumida.com
Sumitomo	(1) 408-451-8441 (USA) 81 75 961-3141 (Japan)	www.ssmc.co.jp

## Detailed Description

The MAX1716/MAX1854/MAX1855 buck controllers are targeted for low-voltage, high-current CPU core power supplies for notebook computers that typically require 18A (or greater) load steps. The proprietary Quick-PWM pulse-width modulator in the converter is specifically designed for handling fast load steps while maintaining a relatively constant operating frequency and inductor operating point over a wide range of input voltages. The Quick-PWM architecture circumvents the poor load-transient timing problems of fixed-frequency current-mode PWMs while also avoiding the problems caused by widely varying switching frequencies in conventional constant on-time and constant off-time PFM schemes.

### +5V Bias Supply (V<sub>CC</sub> and V<sub>DD</sub>)

The MAX1716/MAX1854/MAX1855 require an external +5V bias supply in addition to the battery. Typically this +5V bias supply is the notebook's 95% efficient +5V system supply. Keeping the bias supply external to the IC improves efficiency and eliminates the cost associated with the +5V linear regulator that would otherwise be needed to supply the PWM circuit and gate drivers. If stand-alone capability is needed, the +5V supply can be generated with an external linear regulator.

The +5V bias supply powers V<sub>CC</sub> (PWM controller) and V<sub>DD</sub> (gate-drive power). The maximum current is:

$$I_{BIAS} = I_{CC} + f \times (Q_{G1} + Q_{G2}) = 10\text{mA to }40\text{mA (typ)}$$

where I<sub>CC</sub> is 700μA (typ), f is the switching frequency, and Q<sub>G1</sub> and Q<sub>G2</sub> are the MOSFET data sheet total gate-charge specification limits at V<sub>GS</sub> = 5V.

The battery input (V<sub>+</sub>) and +5V bias inputs (V<sub>CC</sub> and V<sub>DD</sub>) can be connected together if the input source is a fixed 4.5V to 5.5V supply. If the +5V bias supply is powered up prior to the battery supply, the enable signal (SHDN) must be delayed until the battery voltage is present to ensure startup.

### Free-Running, Constant-On-Time PWM Controller with Input Feed-Forward

The Quick-PWM control architecture is a constant-on-time, current-mode type with voltage feed-forward (Figure 2). This architecture relies on the output ripple voltage to provide the PWM ramp signal. Thus, the output filter capacitor's ESR acts as a feedback resistor. The control algorithm is simple: the high-side switch on-time is determined solely by a one-shot whose period is inversely proportional to input voltage and directly proportional to output voltage (see *On-Time One-Shot*). Another one-shot sets a minimum off-time (400ns typ). The on-time one-shot is triggered if the error compar-

# High-Speed, Adjustable, Synchronous Step-Down Controllers with Integrated Voltage Positioning

MAX1716/MAX1854/MAX1855

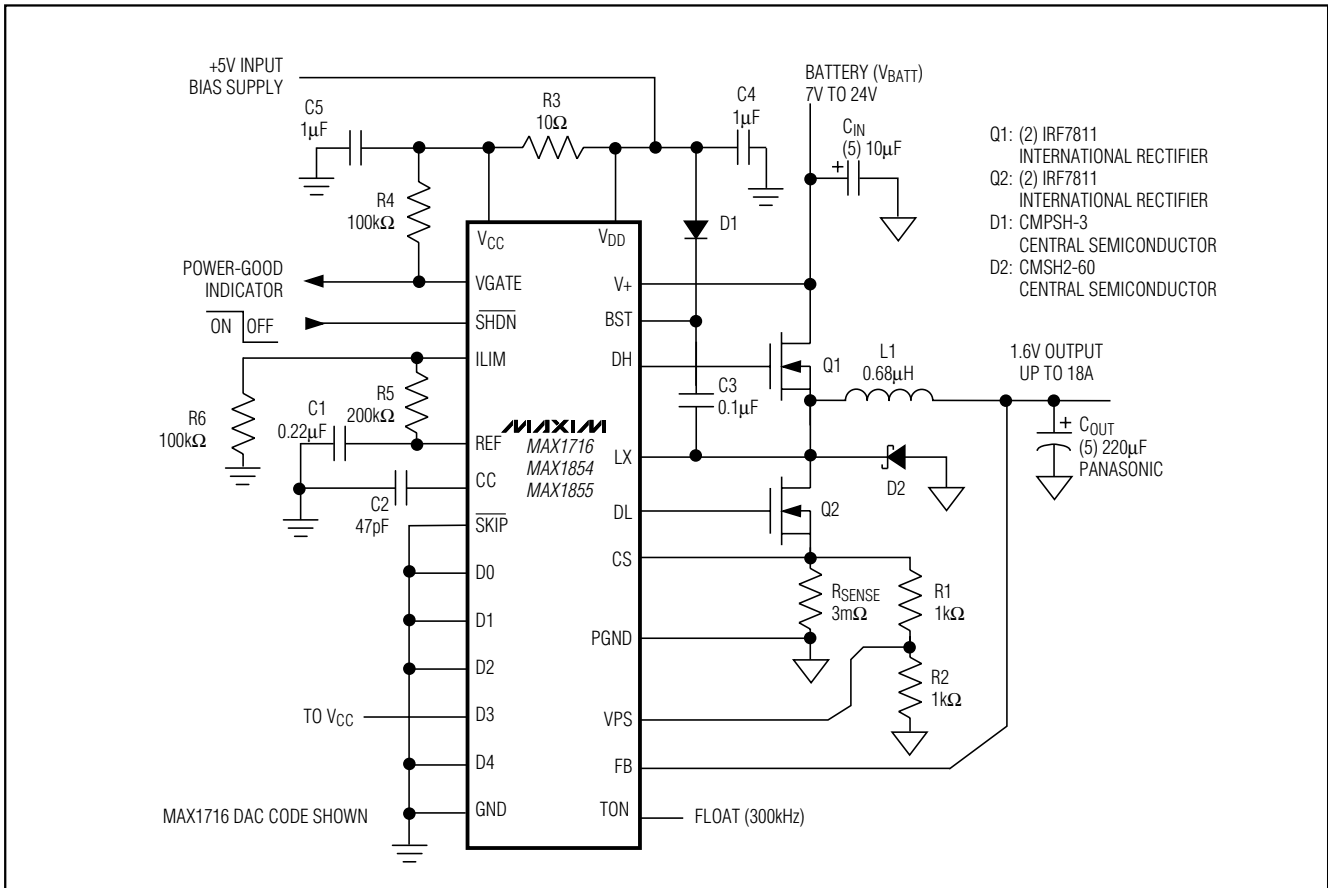

Figure 1. Standard High-Power Application (Circuit #1)

tor is low, the low-side switch current is below the current-limit threshold, and the minimum off-time one-shot has timed out.

## On-Time One-Shot (TON)

The heart of the PWM core is the one-shot that sets the high-side switch on-time. This fast, low-jitter, adjustable one-shot includes circuitry that varies the on-time in response to the input and output voltages. The high-side switch on-time is inversely proportional to  $V+$ , and directly proportional to the output voltage as set by the DAC code. This algorithm results in a nearly constant switching frequency despite the lack of a fixed-frequency clock generator. The benefits of a constant switching frequency are twofold: first, the frequency can be selected to avoid noise-sensitive regions, such as the 455kHz IF band; second, the inductor ripple-current operating point remains relatively constant, resulting in

easy design methodology and predictable output voltage ripple.

$$\text{On-Time} = K \times (V_{\text{OUT}} + 75\text{mV}) / V+$$

where  $K$  is set by the TON pin-strap connection, and 75mV is an approximation to accommodate for the expected drop across the low-side MOSFET switch and current-sense resistor (Table 3).

The on-time one-shot has good accuracy at the operating points specified in the *Electrical Characteristics* table. On-times at operating points far removed from the conditions specified in the *Electrical Characteristics* table can vary over a wide range. For example, the 550kHz setting will typically run about 10% slower with inputs much greater than the +5V due to the very short on-times required.

While the on-time is set by TON,  $V+$ , and the output voltage, other factors also contribute to the overall

# High-Speed, Adjustable, Synchronous Step-Down Controllers with Integrated Voltage Positioning

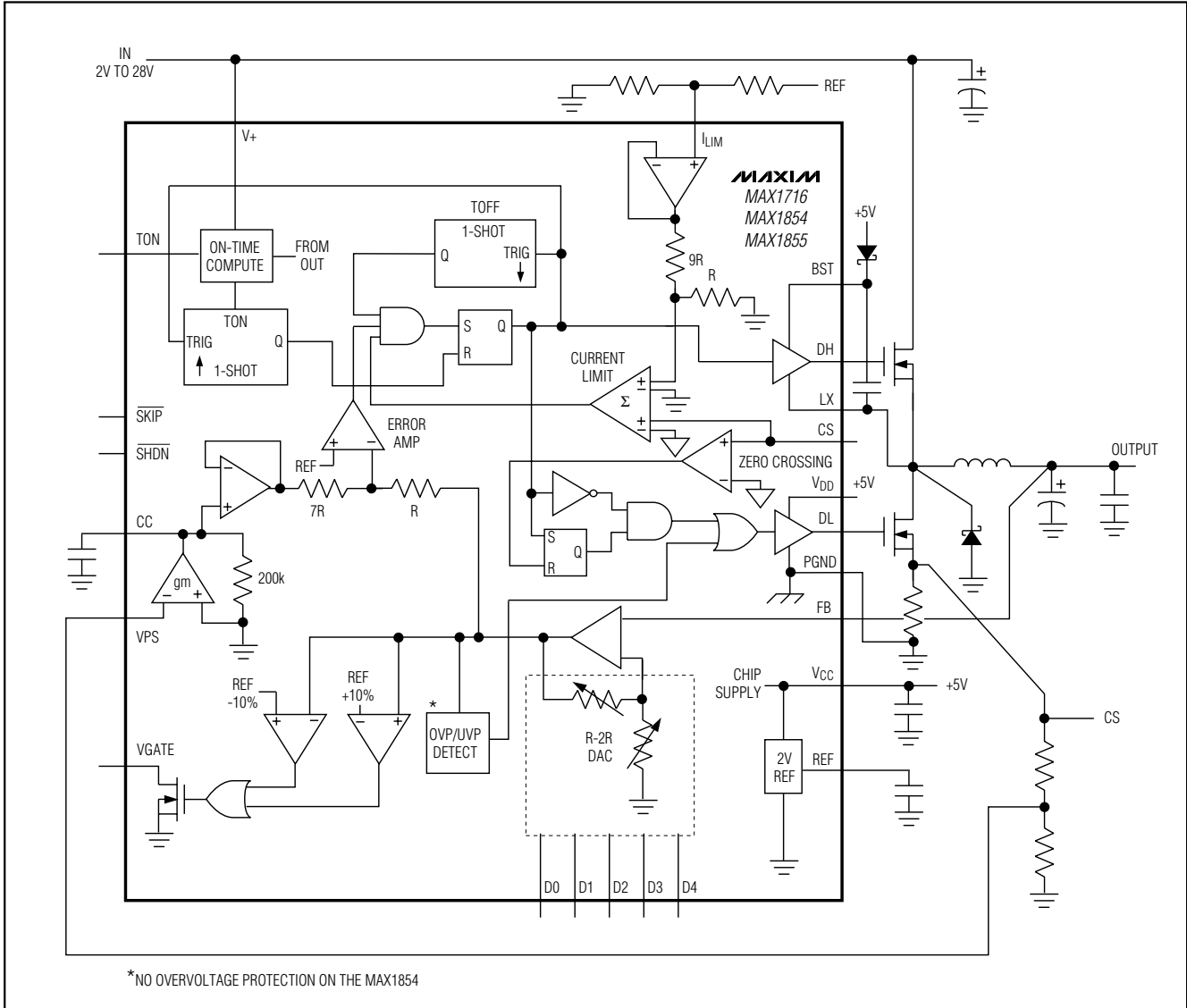

Figure 2. Functional Diagram

Table 3. Approximate K-Factor Errors

TON SETTING (kHz)	K-FACTOR ( $\mu\text{s}$ )	APPROXIMATE K-FACTOR ERROR (%)	MIN RECOMMENDED $V_{\text{BATT}}$ AT $V_{\text{OUT}} = 1.6\text{V}$ (V)
200	5	$\pm 9$	2.04
300	3.3	$\pm 11$	2.28
400	2.2	$\pm 15$	2.84
550	1.8	$\pm 20$	3.55

# High-Speed, Adjustable, Synchronous Step-Down Controllers with Integrated Voltage Positioning

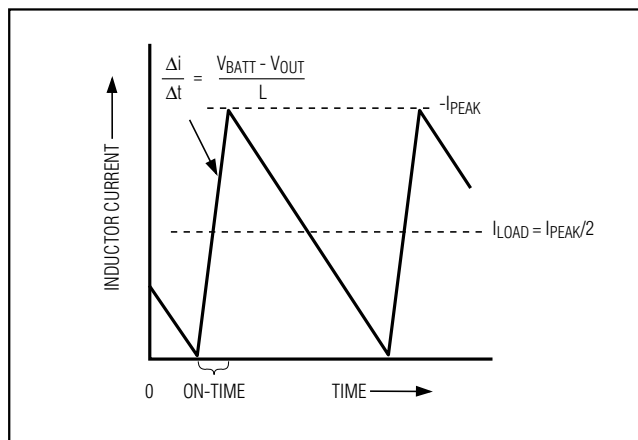

Figure 3. Pulse-Skipping/Discontinuous Crossover Point

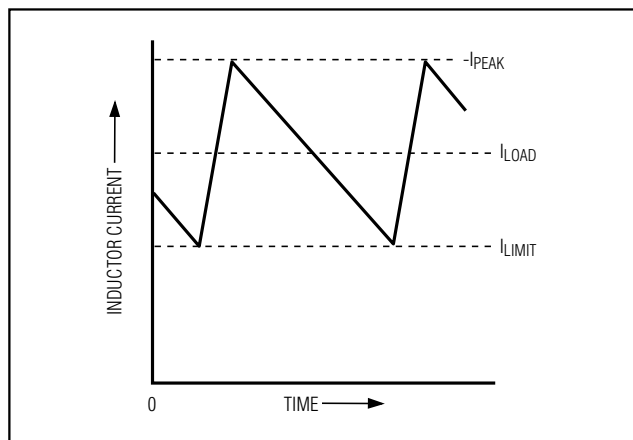

Figure 4. "Valley" Current-Limit Threshold Point

switching frequency. The on-time guaranteed in the *Electrical Characteristics* table is influenced by switching delays in the external high-side MOSFET. Resistive losses—including the inductor, both MOSFETs, output capacitor ESR, and PC board copper losses in the output and ground—tend to raise the switching frequency at higher output currents. Switch dead-time can increase the effective on-time, reducing the switching frequency. This effect occurs only in PWM mode (SKIP = high) when the inductor current reverses at light or negative load currents. With reversed inductor current, the inductor's EMF causes LX to go high earlier than normal, extending the on-time by a period equal to the DH-rising dead-time.

When the controller operates in continuous mode, the dead-time is no longer a factor and the actual switching frequency is:

$$f = (V_{OUT} + V_{DROP1}) / [t_{ON} \times (V_{+} + V_{DROP1} - V_{DROP2})]$$

where  $V_{DROP1}$  is the sum of the parasitic voltage drops in the inductor discharge path, including synchronous rectifier, inductor, and PC board resistances;  $V_{DROP2}$  is the sum of the resistances in the charging path, including high-side switch, inductor, and PC board resistances; and  $t_{ON}$  is the on-time calculated by the MAX1716/MAX1854/MAX1855.

### Automatic Pulse-Skipping Switchover

In skip mode (SKIP = low), an inherent automatic switchover to PFM takes place at light loads (Figure 3). This switchover is controlled by a comparator that truncates the low-side switch on-time at the inductor current's zero crossing. This mechanism causes the threshold between pulse-skipping PFM and nonskipping PWM operation to coincide with the boundary

between continuous and discontinuous inductor-current operation. For an input voltage ( $V_{+}$ ) range of 7V to 24V, this threshold is relatively constant, with only a minor dependence on the input voltage:

$$I_{LOAD(SKIP)} \approx \left( \frac{K \times V_{OUT}}{2L} \right) \left( \frac{V_{+} - V_{OUT}}{V_{+}} \right)$$

where  $K$  is the on-time scale factor (Table 3). The load-current level at which PFM/PWM crossover occurs,  $I_{LOAD(SKIP)}$ , is equal to 1/2 the peak-to-peak ripple current, which is a function of the inductor value (Figure 3). For example, in the standard application circuit with  $K = 3.3\mu s$  (300kHz),  $V_{BATT} = 12V$ ,  $V_{OUT} = 1.6V$ , and  $L = 0.68\mu H$ , switchover to pulse-skipping operation occurs at  $I_{LOAD} = 2.3A$  or about 1/4 full load. The crossover point occurs at an even lower value if a swinging (soft-saturation) inductor is used.

The switching waveforms may appear noisy and asynchronous when light loading causes pulse-skipping operation; this is a normal operating condition that improves light-load efficiency. Trade-offs in PFM noise vs. light-load efficiency are made by varying the inductor value. Generally, low inductor values produce a broader efficiency vs. load curve, while higher values result in higher full-load efficiency (assuming that the coil resistance remains fixed) and less output voltage ripple. Penalties for using higher inductor values include larger physical size and degraded load-transient response (especially at low input voltage levels).

### Forced-PWM Mode (SKIP = High)

The low-noise, forced-PWM mode (SKIP driven high) disables the zero-crossing comparator that controls the

# High-Speed, Adjustable, Synchronous Step-Down Controllers with Integrated Voltage Positioning

Table 4. Operating Mode Truth Table

SHDN	SKIP	DL	MODE	COMMENTS
0	X	High	Shutdown	Micropower shutdown state.
1	GND	Switching	Normal Operation	Automatic switchover from PWM mode to pulse-skipping PFM mode at light loads. Prevents inductor current from recirculating into the input.
1	VCC	Switching	Forced PWM	Low-noise forced-PWM mode causes inductor current to reverse at light loads and suppresses pulse-skipping operation.
1	Below GND	Switching	No-Fault Test Mode	Test mode with overvoltage, undervoltage, and thermal shutdown faults disabled. Otherwise, the converter operates as if SKIP = GND.

X = Don't care

low-side switch on-time. The resulting low-side gate-drive waveform is forced to be the complement of the high-side gate-drive waveform. This, in turn causes the inductor current to reverse at light loads, as the PWM loop strives to maintain a duty ratio of  $V_{OUT}/V_{+}$ . The benefit of forced-PWM mode is to keep the switching frequency nearly constant, but it results in higher no-load supply current that can be 10mA to 40mA, depending on the external MOSFETs and switching frequency.

Forced-PWM mode is most useful for minimizing audio-frequency noise and improving the cross-regulation of multiple-output applications that use a flyback transformer or coupled inductor.

### Current-Limit Circuit (ILIM)

The current-limit circuit employs a unique “valley” current-sensing algorithm. If the current-sense signal is above the current-limit threshold, the MAX1716/MAX1854/MAX1855 will not initiate a new cycle (Figure 4). The actual peak current is greater than the current-limit threshold by an amount equal to the inductor ripple current. Therefore, the exact current-limit characteristic and maximum load capability are a function of the current-limit threshold, inductor value, and input voltage. The reward for this uncertainty is robust, loss-less overcurrent sensing. When combined with the UVP protection circuit, this current-limit method is effective in almost every circumstance.

There is also a negative current limit that prevents excessive reverse inductor currents when  $V_{OUT}$  is sinking current. The negative current-limit threshold is set to approximately 120% of the positive current limit and

therefore tracks the positive current limit when ILIM is adjusted.

The MAX1716/MAX1854/MAX1855 measure the current by sensing the voltage between CS and PGND. Connect an external sense resistor between the source of the low-side N-channel MOSFET and PGND. This same resistor is also used to generate the input voltage for the VPS input (see *Setting Voltage Positioning*). Reducing the sense voltage increases the relative measurement error. However, the configuration eliminates the uncertainty of using the low-side MOSFET on-resistance to measure the current, so the resulting current-limit tolerance is tighter when sensing with a 1% sense resistor.

In some applications, the signal required for voltage positioning is much smaller than the minimum current-limit voltage (50mV). There are two options for addressing this issue. One method is to use a larger current-sense resistor to develop the appropriate current-limit voltage and divide down this signal to obtain the desired VPS input. This solution provides the maximum current-limit accuracy. Alternatively, select a sense resistance to generate the desired VPS voltage and connect CS to LX. This results in minimum power-dissipation with reduced current-limit accuracy. The default 120mV current limit ( $ILIM = V_{CC}$ ) accommodates current-limit detection using the low-side power MOSFET and low-value sense resistor.

The voltage at ILIM sets the current-limit threshold. For voltages from 500mV to 2V, the current-limit threshold voltage is precisely  $0.1 \times V_{ILIM}$ . Set this voltage with a resistive divider between REF and GND. The current-limit threshold defaults to 120mV when ILIM is tied to

# High-Speed, Adjustable, Synchronous Step-Down Controllers with Integrated Voltage Positioning

MAX1716/MAX1854/MAX1855

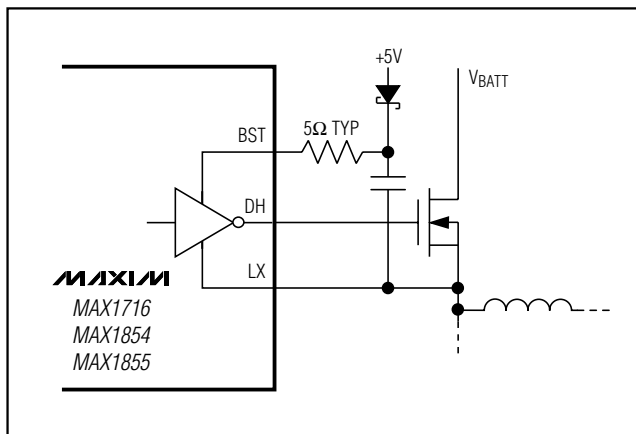

Figure 5. Reducing the Switching-Node Rise Time

V<sub>CC</sub>. The logic threshold for switchover to the 120mV default value is approximately V<sub>CC</sub> - 1V.

Carefully observe the PC board layout guidelines to ensure that noise and DC errors don't corrupt the current-sense signals seen by CS and PGND. The IC must be mounted close to the current-sense resistor with short, direct traces making a Kelvin sense connection.

## MOSFET Gate Drivers (DH and DL)

The DH and DL drivers are optimized for driving moderate-sized, high-side and larger, low-side power MOSFETs. This is consistent with the low duty factor seen in the notebook CPU environment, where a large V<sub>IN</sub> - V<sub>OUT</sub> differential exists. An adaptive dead-time circuit monitors the DL output and prevents the high-side FET from turning on until DL is fully off. There must be a low-resistance, low-inductance path from the DL driver to the MOSFET gate in order for the adaptive dead-time circuit to work properly. Otherwise, the sense circuitry in the MAX1716/MAX1854/MAX1855 will interpret the MOSFET gate as "off" while there is actually still charge left on the gate. Use very short, wide traces measuring 10 to 20 squares (50 to 100 mils wide if the MOSFET is 1 inch from the device). The dead time at the other edge (DH turning off) is determined by a fixed 35ns internal delay.

The internal pulldown transistor that drives DL low is robust, with a 0.5Ω (typ) on-resistance. This helps prevent DL from being pulled up during the fast rise time of the LX node, due to capacitive coupling from the

drain to the gate of the low-side synchronous-rectifier MOSFET. However, for high-current applications, some combinations of high- and low-side FETs may cause excessive gate-drain coupling, leading to poor efficiency, EMI, and shoot-through currents. This is often remedied by adding a resistor in series with BST, which increases the turn-on time of the high-side FET without degrading the turn-off time (Figure 5).

## DAC Converter (D0-D4)

The digital-to-analog converter (DAC) programs the output voltage. It receives a preset digital code from the VID inputs (D0-D4), which contain weak internal pullups to eliminate external resistors. They can also be driven by digital logic, general-purpose I/O, or an external multiplexer. The available DAC codes and resulting output voltages (Table 5) are compatible with Intel's mobile Pentium III™ specifications.

D0-D4 can be changed while the regulator is active, initiating a transition to a new output voltage level. Change D0-D4 synchronously to avoid errors during a V<sub>OUT</sub> transition. If the skew between bits exceeds 1μs, incorrect DAC outputs may cause a partial transition to the wrong voltage level, followed by the intended transition to the correct voltage level, lengthening the overall transition time.

When changing the MAX1855 DAC code while powered up, the undervoltage protection feature can be activated if the code change increases the output voltage by more than 120%. For example, a transition from any DAC code below 0.8V to 1.75V will activate the undervoltage protection. In the preceding example, transitioning from 0.8V to 1.35V and then from 1.35V to 1.75V avoids activating the undervoltage protection feature.

## Shutdown ( $\overline{\text{SHDN}}$ )

Drive  $\overline{\text{SHDN}}$  low to force the MAX1716/MAX1854/MAX1855 into a low-current shutdown state. Shutdown turns on the low-side MOSFET by forcing the DL gate driver high, which discharges the output capacitor and forces the output to ground. Drive or connect  $\overline{\text{SHDN}}$  to V<sub>CC</sub> for normal operation. A rising edge on  $\overline{\text{SHDN}}$  clears the fault latch.

## Power-on Reset

Power-on reset (POR) occurs when V<sub>CC</sub> rises above approximately 2V. This resets the fault latch and soft-start counter, preparing the regulator for operation.

Pentium III is a trademark of Intel Corp.

# High-Speed, Adjustable, Synchronous Step-Down Controllers with Integrated Voltage Positioning

Table 5. Output Voltage vs. DAC Codes

D4	D3	D2	D1	D0	OUTPUT VOLTAGE		
					MAX1716	MAX1854	MAX1855
0	0	0	0	0	No CPU*	2.000V	1.750V
0	0	0	0	1	No CPU*	1.950V	1.700V
0	0	0	1	0	No CPU*	1.900V	1.650V
0	0	0	1	1	No CPU*	1.850V	1.600V
0	0	1	0	0	No CPU*	1.800V	1.550V
0	0	1	0	1	No CPU*	1.750V	1.500V
0	0	1	1	0	No CPU*	1.700V	1.450V
0	0	1	1	1	No CPU*	1.650V	1.400V
0	1	0	0	0	1.600V	1.600V	1.350V
0	1	0	0	1	1.550V	1.550V	1.300V
0	1	0	1	0	1.500V	1.500V	1.250V
0	1	0	1	1	1.450V	1.450V	1.200V
0	1	1	0	0	1.400V	1.400V	1.150V
0	1	1	0	1	1.350V	1.350V	1.100V
0	1	1	1	0	1.300V	1.300V	1.050V
0	1	1	1	1	No CPU*	No CPU*	1.000V
1	0	0	0	0	1.275V	1.275V	0.975V
1	0	0	0	1	1.250V	1.250V	0.950V
1	0	0	1	0	1.225V	1.225V	0.925V
1	0	0	1	1	1.200V	1.200V	0.900V
1	0	1	0	0	1.175V	1.175V	0.875V
1	0	1	0	1	1.150V	1.150V	0.850V
1	0	1	1	0	1.125V	1.125V	0.825V
1	0	1	1	1	1.100V	1.100V	0.800V
1	1	0	0	0	1.075V	1.075V	0.775V
1	1	0	0	1	1.050V	1.050V	0.750V
1	1	0	1	0	1.025V	1.025V	0.725V
1	1	0	1	1	1.000V	1.000V	0.700V
1	1	1	0	0	0.975V	0.975V	0.675V
1	1	1	0	1	0.950V	0.950V	0.650V
1	1	1	1	0	0.925V	0.925V	0.625V
1	1	1	1	1	No CPU*	No CPU*	0.600V

\*Note: In the no-CPU state, DH and DL are held low.

### Undervoltage Lockout and Soft-Start

V<sub>CC</sub> undervoltage lockout (UVLO) circuitry inhibits switching, forces VGATE low, and drives the DL output high. If the V<sub>CC</sub> voltage drops below 4.2V, it is assumed that there is not enough supply voltage to

make valid decisions. To protect the output from over-voltage faults, DL is forced high in this mode. This will force the output to GND and results in large negative inductor current that pulls the output below GND. If V<sub>CC</sub> is likely to drop in this fashion, the output can be

# High-Speed, Adjustable, Synchronous Step-Down Controllers with Integrated Voltage Positioning

clamped with a Schottky diode to GND to reduce the negative excursion.

To ensure correct startup,  $V+$  should be present before  $V_{CC}$ . If the converter attempts to bring the output into regulation without  $V+$  present, the fault latch will trip.

After  $V_{CC}$  rises above 4.2V, an internal digital soft-start timer begins to ramp up the maximum allowed current limit. The ramp occurs in five steps: 20%, 40%, 60%, 80%, and 100%, with 100% load current available after 1.7ms  $\pm$ 50%.

## Power-Good Output (VGATE)

VGATE is the open-drain output of a window comparator. This power-good output remains high impedance as long as the output voltage is within  $\pm$ 10% of the regulation voltage. When the output voltage is greater than or less than the  $\pm$ 10% window limits, the internal MOSFET is activated and pulls the output low. Any fault condition forces VGATE low until the fault is cleared. VGATE is also low in shutdown, undervoltage lockout, and during soft-start. For logic-level output voltages, connect an external pullup resistor between VGATE and  $V_{CC}$  (or  $V_{DD}$ ). A 100k $\Omega$  resistor works well in most applications.

## Output Overvoltage Protection (MAX1716/MAX1855 only)

The overvoltage protection (OVP) circuit is designed to protect against a shorted high-side MOSFET by drawing high current and activating the battery's protection circuit. The output voltage is continuously monitored for overvoltage. If the output exceeds the OVP threshold (1.9V with the MAX1716, 2.0V with the MAX1855), OVP is triggered and the circuit shuts down. The DL low-side gate-driver output latches high until  $\overline{\text{SHDN}}$  toggles or  $V_{CC}$  pulses below 1V. This action turns on the synchronous-rectifier MOSFET with 100% duty cycle and, in turn, rapidly discharges the output filter capacitor, forcing the output to ground. If the condition that caused the overvoltage (such as a shorted high-side MOSFET) persists, the battery's internal protection circuit will engage.

OVP can be defeated through the no-fault test mode (see *No-Fault Test Mode*).

## Output Undervoltage Protection

The output undervoltage protection (UVP) function is similar to foldback current limiting, but employs a timer rather than a variable current limit. If the regulator's output voltage is under 40% of the nominal value, anytime after the 20ms undervoltage fault-blanking time, the PWM is latched off and won't restart until  $\overline{\text{SHDN}}$  toggles or  $V_{CC}$  pulses below 1V.

UVP can be defeated through the no-fault test mode (see *No-Fault Test Mode*).

## Thermal Fault Protection

The MAX1716/MAX1854/MAX1855 feature a thermal fault protection circuit. When the temperature rises above +150°C, the DL low-side gate-driver output latches high until  $\overline{\text{SHDN}}$  toggles or  $V_{CC}$  pulses below 1V. The threshold has +10°C of thermal hysteresis, which prevents the regulator from restarting until the die cools off.

## No-Fault Test Mode

The over/undervoltage protection features can complicate the process of debugging prototype breadboards since there are at most a few milliseconds in which to determine what went wrong. Therefore, a test mode is provided to disable the OVP, UVP, and thermal shutdown features, and clear the fault latch if it has been set. The PWM operates as if  $\overline{\text{SKIP}}$  were low (SKIP mode).

The no-fault test mode is entered by sinking 1.5mA from  $\overline{\text{SKIP}}$  through an external negative voltage source in series with a resistor.  $\overline{\text{SKIP}}$  is clamped to GND with a silicon diode, so choose the resistor value equal to  $(V_{\text{FORCE}} - 0.65\text{V}) / 1.5\text{mA}$ .

## Design Procedure

Firmly establish the input voltage range and maximum load current before choosing a switching frequency and inductor operating point (ripple-current ratio). The primary design trade-off lies in choosing a good switching frequency and inductor operating point. The following four factors dictate the design:

**Input voltage range:** The maximum value ( $V_{+(\text{MAX})}$ ) must accommodate the worst-case high AC-adaptor voltage. The minimum value ( $V_{+(\text{MIN})}$ ) must account for the lowest input voltage after drops due to connectors, fuses, and battery selector switches. If there is a choice at all, lower input voltages result in better efficiency.

**Maximum load current:** There are two values to consider. The peak load current ( $I_{\text{LOAD}(\text{MAX})}$ ) determines the instantaneous component stresses and filtering requirements, and thus drives output capacitor selection, inductor saturation rating, and the design of the current-limit circuit. The continuous load current ( $I_{\text{LOAD}}$ ) determines the thermal stresses and thus drives the selection of input capacitors, MOSFETs, and other critical heat-contributing components. Modern notebook CPUs generally exhibit  $I_{\text{LOAD}} = I_{\text{LOAD}(\text{MAX})} \times 80\%$ .

**Switching frequency:** This choice determines the basic trade-off between size and efficiency. The opti-

# High-Speed, Adjustable, Synchronous Step-Down Controllers with Integrated Voltage Positioning

mal frequency is largely a function of maximum input voltage, due to MOSFET switching losses that are proportional to frequency and  $V+^2$ . The optimum frequency is also a moving target, due to rapid improvements in MOSFET technology that are making higher frequencies more practical.

**Inductor operating point:** This choice provides trade-offs between size vs. efficiency. Low inductor values cause large ripple currents, resulting in the smallest size, but poor efficiency and high output noise. The minimum practical inductor value is one that causes the circuit to operate at the edge of critical conduction (where the inductor current just touches zero with every cycle at maximum load). Inductor values lower than this grant no further size-reduction benefit.

The MAX1716/MAX1854/MAX1855's pulse-skipping algorithm initiates skip mode at the critical-conduction point. Thus, the inductor operating point also determines the load-current value at which PFM/PWM switchover occurs. The optimum point is usually found between 20% and 50% ripple current.

The inductor ripple current impacts transient-response performance, especially at low  $V_{IN} - V_{OUT}$  differentials. Low inductor values allow the inductor current to slew faster, replenishing charge removed from the output filter capacitors by a sudden load step. The amount of output sag is also a function of the maximum duty factor, which can be calculated from the on-time and minimum off-time:

$$V_{SAG} = \frac{(I_{LOAD1} - I_{LOAD2})^2 \times L \times \left[ \left( K \times \frac{V_{OUT}}{V+} \right) - t_{OFF(MIN)} \right]}{2 \times C_{OUT} \times V_{OUT} \times \left[ K \times \left( \frac{V+ - V_{OUT}}{V+} \right) - t_{OFF(MIN)} \right]}$$

where  $t_{OFF(MIN)}$  is the minimum off-time (see *Electrical Characteristics*), and  $K$  is from Table 3.

## Inductor Selection

The switching frequency and operating point (% ripple or LIR) determine the inductor value as follows:

$$L = \frac{V_{OUT} \times (V+ - V_{OUT})}{V+ \times f_{SW} \times LIR \times I_{LOAD(MAX)}}$$

Example:  $I_{LOAD(MAX)} = 18A$ ,  $V_{IN} = 7V$ ,  $V_{OUT} = 1.6V$ ,  $f_{SW} = 300kHz$ , 30% ripple current or  $LIR = 0.3$ .

$$L = \frac{1.6V \times (7V - 1.6V)}{7V \times 300kHz \times 0.30 \times 18A} = 0.76\mu H$$

Find a low-loss inductor having the lowest possible DC resistance that fits in the allotted dimensions. Ferrite cores are often the best choice, although powdered iron is inexpensive and can work well at 200kHz. The core must be large enough not to saturate at the peak inductor current ( $I_{PEAK}$ ).

$$I_{PEAK} = I_{LOAD(MAX)} + (I_{LOAD(MAX)} \times LIR / 2)$$

## Setting the Current Limit

The minimum current-limit threshold must be great enough to support the maximum load current when the current limit is at the minimum tolerance value. The valley of the inductor current occurs at  $I_{LOAD(MAX)}$  minus half of the ripple current; therefore:

$$I_{LIMIT(LOW)} > I_{LOAD(MAX)} - (I_{LOAD(MAX)} \times LIR / 2)$$

where  $I_{LIMIT(LOW)}$  equals the minimum current-limit threshold voltage divided by  $R_{SENSE}$ . For the 120mV default setting, the minimum current-limit threshold is 110mV.

Connect  $I_{LIM}$  to  $V_{CC}$  for a default 120mV current-limit threshold. In the adjustable mode, the current-limit threshold is precisely 1/10th the voltage seen at  $I_{LIM}$ . For an adjustable threshold, connect a resistive divider from REF to GND, with  $I_{LIM}$  connected to the center tap. The external 0.5V to 2.0V adjustment range corresponds to a current-limit threshold of 50mV to 200mV. When adjusting the current limit, use 1% tolerance resistors and a 10 $\mu A$  divider current to prevent a significant increase of errors in the current-limit value.

## Output Capacitor Selection

The output filter capacitor must have low enough effective series resistance (ESR) to meet output ripple and load-transient requirements, yet have high enough ESR to satisfy stability requirements. Also, the capacitance value must be high enough to absorb the inductor energy going from a full-load to no-load condition without tripping the overvoltage protection circuit.

In CPU  $V_{CORE}$  converters and other applications where the output is subject to violent load transients, the output capacitor's size typically depends on how much ESR is needed to prevent the output from dipping too low under a load transient. Ignoring the sag due to finite capacitance:

$$RESR = V_{STEP(MAX)} / I_{LOAD(MAX)}$$

The actual  $\mu F$  capacitance value required relates to the physical size needed to achieve low ESR, as well as to the chemistry of the capacitor technology. Thus, the capacitor is usually selected by ESR and voltage rating rather than by capacitance value (this is true of tantalums, OS-CONs, and other electrolytics).

# High-Speed, Adjustable, Synchronous Step-Down Controllers with Integrated Voltage Positioning

When using low-capacity filter capacitors, such as ceramic or polymer types, capacitor size is usually determined by the capacity needed to prevent  $V_{SAG}$ , and  $V_{SOAR}$  from causing problems during load transients. Generally, once enough capacitance is added to meet the overshoot requirement, undershoot at the rising load edge is no longer a problem (see the  $V_{SAG}$  equation in the *Design Procedure*). The amount of overshoot due to stored inductor energy can be calculated as:

$$V_{SOAR} \approx (L \times I_{PEAK}^2) / (2 \times C_{OUT} \times V_{OUT})$$

where  $I_{PEAK}$  is the peak inductor current.

## Output Capacitor Stability Considerations

Stability is determined by the value of the ESR zero relative to the switching frequency. The boundary of instability is given by the following equation:

$$f_{ESR} = f_{SW} / \pi$$

$$\text{where: } f_{ESR} = 1 / (2 \times \pi \times R_{ESR} \times C_{OUT})$$

For a standard 300kHz application, the ESR zero frequency must be well below 95kHz, preferably below 50kHz. Tantalum, Sanyo POSCAP, and Panasonic SP capacitors in widespread use at the time of this publication have typical ESR zero frequencies below 30kHz. In the standard application used for inductor selection, the ESR needed to support a 50mVp-p ripple is  $50\text{mV} / (18\text{A} \times 0.3) = 9.3\text{m}\Omega$ . Five 220 $\mu\text{F}/2.5\text{V}$  Panasonic SP capacitors in parallel provide 3m $\Omega$  (max) ESR. Their typical combined ESR results in a zero at 48kHz.

Don't put high-value ceramic capacitors directly across the output without taking precautions to ensure stability. Ceramic capacitors have a high ESR zero frequency and may cause erratic, unstable operation. However, it's easy to add enough series resistance by placing the capacitors a couple of inches downstream from the junction of the inductor and FB pin.

Unstable operation manifests itself in two related but distinctly different ways: double-pulsing and fast-feedback loop instability.

Double-pulsing occurs due to noise on the output or because the ESR is so low that there isn't enough voltage ramp in the output voltage signal. This "fools" the error comparator into triggering a new cycle immediately after the minimum off-time period has expired. Double-pulsing is more annoying than harmful, resulting in nothing worse than increased output ripple. However, it can indicate the possible presence of loop instability, which is caused by insufficient ESR.

Loop instability can result in oscillations at the output after line or load perturbations that can cause the out-

put voltage to rise above or fall below the tolerance limit.

The easiest method for checking stability is to apply a very fast zero-to-max load transient and carefully observe the output voltage ripple envelope for overshoot and ringing. It can help to simultaneously monitor the inductor current with an AC current probe. Don't allow more than one cycle of ringing after the initial step-response under/overshoot.

## Input Capacitor Selection

The input capacitor must meet the ripple-current requirement ( $I_{RMS}$ ) imposed by the switching currents defined by the following equation:

$$I_{RMS} = I_{LOAD} \frac{\sqrt{V_{OUT}(V_+ - V_{OUT})}}{V_+}$$

For most applications, nontantalum chemistries (ceramic, aluminum, or OS-CON) are preferred due to their resistance to inrush surge currents typical of systems with a mechanical switch or connector in series with the input. If the MAX1716/MAX1854/MAX1855 are operated as the second stage of a two-stage power-conversion system, tantalum input capacitors are acceptable. In either configuration, choose an input capacitor that exhibits  $<+10^\circ\text{C}$  temperature rise at the RMS input current for optimal circuit longevity.

## Power MOSFET Selection

Most of the following MOSFET guidelines focus on the challenge of obtaining high load-current capability ( $>18\text{A}$ ) when using high-voltage ( $>20\text{V}$ ) AC adapters. Low-current applications usually require less attention.

For maximum efficiency, choose a high-side MOSFET that has conduction losses equal to the switching losses at the average input voltage (3 Li+ cells = 11V, 4 Li+ cells = 14V). Check to ensure that conduction losses plus switching losses don't exceed the package ratings or violate the overall thermal budget at the maximum and minimum input voltages.

Choose a low-side MOSFET that has the lowest possible on-resistance ( $R_{DS(ON)}$ ), comes in a moderate-sized package (i.e., one or two SO-8s, DPAK or D<sup>2</sup>PAK), and is reasonably priced. Make sure that the DL gate driver can supply sufficient current to support the gate charge and the current injected into the parasitic gate-to-drain capacitor caused by the high-side MOSFET turning on; otherwise, cross-conduction problems may occur.

# High-Speed, Adjustable, Synchronous Step-Down Controllers with Integrated Voltage Positioning

## MOSFET Power Dissipation

Worst-case conduction losses occur at the duty factor extremes. For the high-side MOSFET (Q1), the worst-case power dissipation due to resistance occurs at the minimum input voltage:

$$PD(Q1 \text{ Resistive}) = (V_{OUT}/V_{+}) \times I_{LOAD}^2 \times R_{DS(ON)}$$

Generally, a small high-side MOSFET is desired to reduce switching losses at high input voltages. However, the  $R_{DS(ON)}$  required to stay within package power-dissipation often limits how small the MOSFET can be. Again, the optimum occurs when the switching losses equal the conduction ( $R_{DS(ON)}$ ) losses. High-side switching losses don't usually become an issue until the input is greater than approximately 15V.

Calculating the power dissipation in the high-side MOSFET (Q1) due to switching losses is difficult since it must allow for difficult quantifying factors that influence the turn-on and turn-off times. These factors include the internal gate resistance, gate charge, threshold voltage, source inductance, and PC board layout characteristics. The following switching-loss calculation provides only a very rough estimate and is no substitute for breadboard evaluation, preferably including verification using a thermocouple mounted on Q1:

$$PD(Q1 \text{ SWITCHING}) = \frac{C_{RSS} V_{+(MAX)}^2 f_{SW} I_{LOAD}}{I_{GATE}}$$

where  $C_{RSS}$  is the reverse transfer capacitance of Q1, and  $I_{GATE}$  is the peak gate-drive source/sink current (1A typ).

Switching losses in the high-side MOSFET can become an insidious heat problem when maximum AC adapter voltages are applied, due to the squared term in the  $C \times V^2 \times f_{SW}$  switching-loss equation. If the high-side MOSFET chosen for adequate  $R_{DS(ON)}$  at low battery voltages becomes extraordinarily hot when biased from  $V_{+(MAX)}$ , consider choosing another MOSFET with lower parasitic capacitance.

For the low-side MOSFET (Q2), the worst-case power dissipation always occurs at maximum input voltage:

$$PD(Q2 \text{ RESISTIVE}) = \left[ 1 - \frac{V_{OUT}}{V_{+(MAX)}} \right] I_{LOAD}^2 R_{DS(ON)}$$

The worst case for MOSFET power dissipation occurs under heavy overloads that are greater than  $I_{LOAD(MAX)}$  but are not quite high enough to exceed the current limit and cause the fault latch to trip. To pro-

tect against this possibility, “overdesign” the circuit to tolerate:

$$I_{LOAD} = I_{LIMIT(HIGH)} + (I_{LOAD(MAX)} \times LIR/2)$$

where  $I_{LIMIT(HIGH)}$  is the maximum valley current allowed by the current-limit circuit, including threshold tolerance and on-resistance variation. The MOSFETs must be very well heatsinked to handle the overload power dissipation.

Choose a Schottky diode (D1) with a forward voltage low enough to prevent the low-side MOSFET body diode from turning on during the dead-time. As a general rule, select a diode with a DC current rating equal to 1/3 of the load current. This diode is optional and can be removed if efficiency isn't critical.

## Setting Voltage Positioning (VPS)

Voltage positioning dynamically changes the output voltage set point in response to the load current. When the output is loaded, the signal fed back from the VPS input adjusts the output voltage set point, thereby decreasing power dissipation. The load transient response of this control loop is extremely fast yet well controlled, so the amount of voltage change can be accurately confined within the limits stipulated in the microprocessor power-supply guidelines. To understand the benefits of dynamically adjusting the output voltage, see *Voltage Positioning and Effective Efficiency*.

The amount of voltage change is set by a small-value sense resistor ( $R_{SENSE}$ ). Place this resistor between the source of the low-side MOSFET and PGND. The voltage developed across this resistor ( $V_{VPS}$ ) relates to the output voltage as follows:

$$V_{OUT} = V_{OUT(PROG)}(1 + A_{VPS}V_{VPS})$$

where  $V_{OUT(PROG)}$  is the programmed output voltage set by the DAC code (Table 5), and the voltage-positioning gain factor ( $A_{VPS}$ ) is 0.175%/mV (see *Electrical Characteristics*). The MAX1716/MAX1854/MAX1855 contain internal clamps to limit the voltage positioning between 10% below and 2% above the programmed output voltage.

The voltage present at VPS can be set in several different ways. Connect VPS directly to CS through a 1k $\Omega$  resistor, or through a resistive divider. When connected directly to CS, the output voltage position is:

$$V_{VPS} = V_{CS} = -I_{LOAD}R_{SENSE}(1 - D)$$

where  $D = V_{OUT} / V_{+}$  is the regulator's duty cycle. However, since the ratio of the output to input voltage is usually relatively large, the effect of the duty cycle on the circuit's performance is not significant. Therefore,

# High-Speed, Adjustable, Synchronous Step-Down Controllers with Integrated Voltage Positioning

MAX1716/MAX1854/MAX1855

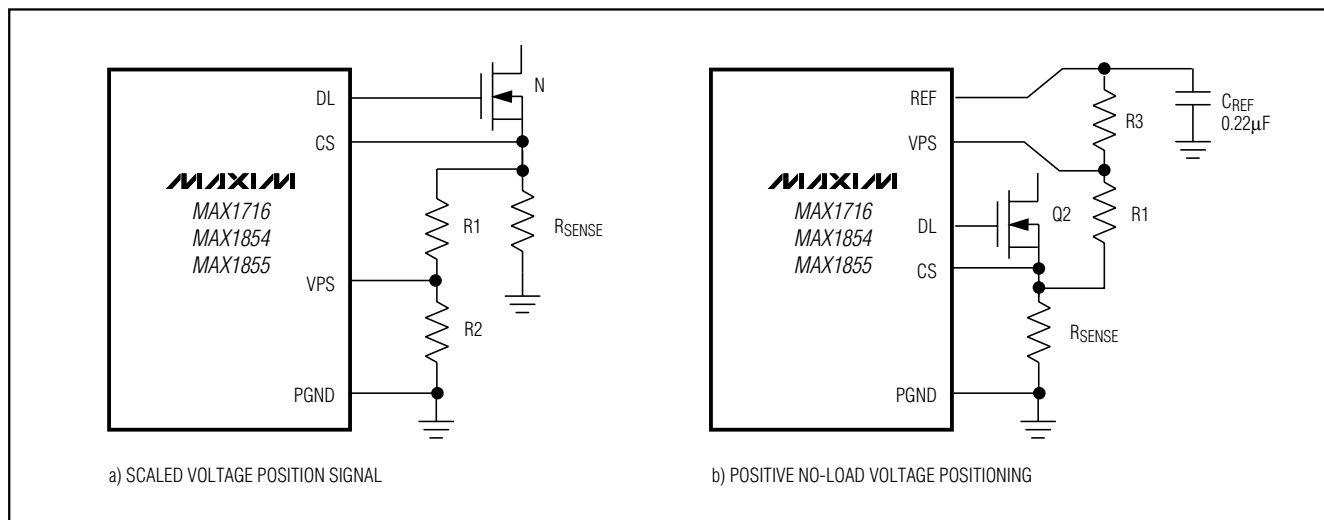

Figure 6. Voltage-Positioning Configurations

the complete expression for the voltage-positioned output depends only upon the value of the current-sense resistor and the load current:

$$V_{OUT} \approx V_{OUT(PROG)}(1 - A_{VPS}I_{LOAD}R_{SENSE})$$

Some applications require the addition of a positive offset to the output voltage to ensure that it remains within the load specifications. The positive offset may be generated by connecting a resistive divider from REF to VPS to CS (Figure 6a). Set R1 to 1kΩ, and use the following equation to calculate R3:

$$R3 = R1 \left[ \frac{V_{REF}A_{VPS}V_{OUT(PROG)}}{V_{OFFSET}} - 1 \right]$$

where VREF is typically 2.0V, and VOFFSET is the required positive offset voltage. When attenuating the voltage-positioning signal, replace R1 with the parallel combination of R1 and R2 (R1//R2), where R2 is the attenuation resistor (Figure 6b).

After a load transient, the output instantly changes by  $ESRC_{OUT} \times \Delta I_{LOAD}$ . Setting the load-dependent voltage position to match this initial load step allows the output voltage to change by  $ESRC_{OUT} \times \Delta I_{LOAD}$  and stay there as long as the load remains unchanged (see *Voltage Positioning and Effective Efficiency*). To set the voltage position equal to the initial voltage drop generated by the output capacitor's ESR, select  $R_{SENSE} = ESRC_{OUT} / (V_{OUT(PROG)} \times A_{VPS})$ .

For applications using a larger current-sense resistor, adjust VVPS by connecting a resistive divider from CS

to VPS to PGND (Figure 6b). Set R1 to 1kΩ, and use the following equation to calculate R2:

$$R2 = R1 \left[ \frac{ESRC_{OUT}}{A_{VPS}V_{OUT(PROG)}R_{SENSE} - ESRC_{OUT}} \right]$$

The MAX1716/MAX1854/MAX1855 voltage-positioning circuit has several advantages over older circuits, which added a fixed voltage offset on the sense point and used a low-value resistor in series with the output. The new circuit can use the same current-sense resistor for both voltage positioning and current-limit detection. This simultaneously provides accurate current limiting and voltage positioning. Since the new circuit adjusts the output voltage within the control loop, the voltage-positioning signal may be internally amplified. The additional gain allows the use of low-value current-sense resistors, so the power dissipated in this sense resistor is significantly lower than a single resistor connected directly in series with the output.

### Voltage-Positioning Compensation (CC)

The voltage-positioning compensation capacitor filters the amplified VPS signal, allowing the user to adjust the dynamics of the voltage-positioning loop. The impedance at this node is approximately 200kΩ, so the pole provided by this node can be approximated by  $1 / (2 \times \pi \times RC)$ . The response time is set with a 47pF to 1000pF capacitor from CC to GND.

# High-Speed, Adjustable, Synchronous Step-Down Controllers with Integrated Voltage Positioning

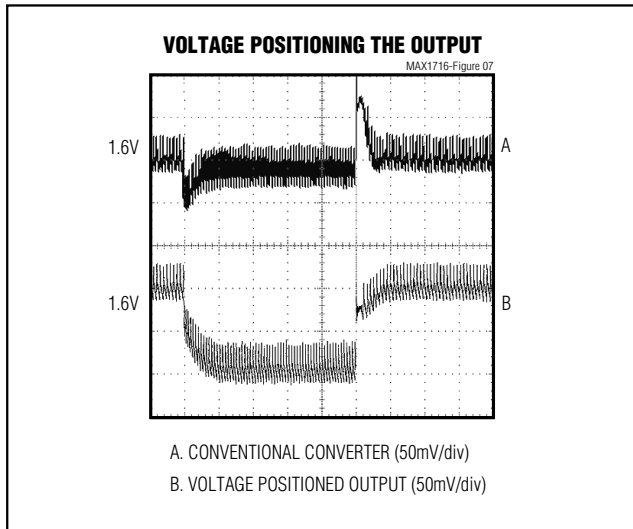

Figure 7. Voltage Positioning the Output

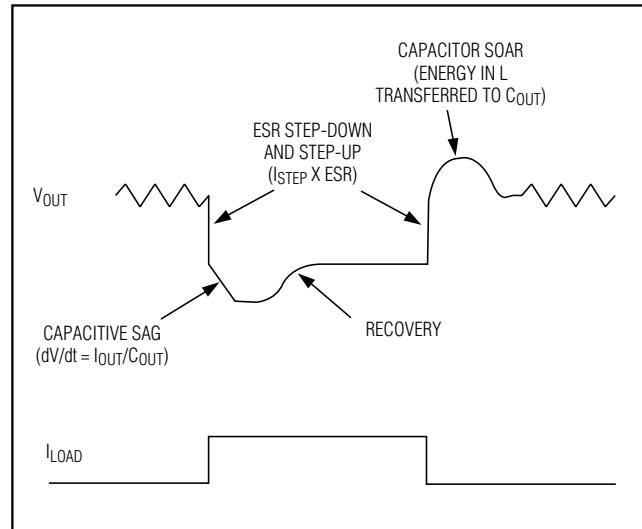

Figure 8. Transient-Response Regions

## Applications Issues

### Voltage Positioning and Effective Efficiency

Powering new mobile processors requires careful attention to detail to reduce cost, size, and power dissipation. As CPUs became more power hungry, it was recognized that even the fastest DC-DC converters were inadequate to handle the transient power requirements. After a load transient, the output instantly changes by  $ESRCOUT \times \Delta I_{LOAD}$ . Conventional DC-DC converters respond by regulating the output voltage back to its nominal state after the load transient occurs (Figure 7). However, the CPU only requires that the output voltage remain above a specified minimum value. Dynamically positioning the output voltage to this lower limit allows the use of fewer output capacitors and reduces power consumption under load.

For a conventional (nonvoltage-positioned) circuit, the total voltage change is:

$$V_{P-P1} = 2 \times (ESRCOUT \times \Delta I_{LOAD}) + V_{SAG} + V_{SOAR}$$

where  $V_{SAG}$  and  $V_{SOAR}$  are defined in Figure 8. Setting the converter to regulate at a lower voltage when under load allows a larger voltage step when the output current suddenly decreases (Figure 7). So the total voltage change for a voltage positioned circuit is:

$$V_{P-P2} = (ESRCOUT \times \Delta I_{LOAD}) + V_{SAG} + V_{SOAR}$$

where  $V_{SAG}$  and  $V_{SOAR}$  are defined in the *Design Procedure*. Since the amplitudes are the same for both circuits ( $V_{P-P1} = V_{P-P2}$ ), the voltage-positioned circuit

requires only twice the ESR. Since the ESR specification is achieved by paralleling several capacitors, fewer units are needed for the voltage-positioned circuit.

An additional benefit of voltage positioning is reduced power consumption at high load currents. Because the output voltage is lower under load, the CPU draws less current. The result is lower power dissipation in the CPU, although some extra power is dissipated in  $R_{SENSE}$ . For a nominal 1.6V, 18A output ( $R_{LOAD} = 89m\Omega$ ), reducing the output voltage 2.9% gives an output voltage of 1.55V and an output current of 17.44A. Given these values, CPU power consumption is reduced from 28.8W to 27.03W. The additional power consumption of  $R_{SENSE}$  is:

$$2.5m\Omega \times (17.44A)^2 = 0.76W$$

and the overall power savings is as follows:

$$28.8W - (27.03W + 0.76W) = 1.01W$$

In effect, 1.8W of CPU dissipation is saved and the power supply dissipates much of the savings, but both the net savings and the transfer of heat away from the CPU are beneficial. Effective efficiency is defined as the efficiency required of a nonvoltage-positioned circuit to equal the total dissipation of a voltage-positioned circuit for a given CPU operating condition.

Calculate effective efficiency as follows:

- 1) Start with the efficiency data for the positioned circuit ( $V_{IN}$ ,  $I_{IN}$ ,  $V_{OUT}$ ,  $I_{OUT}$ ).
- 2) Model the load resistance for each data point:

# High-Speed, Adjustable, Synchronous Step-Down Controllers with Integrated Voltage Positioning

$$R_{LOAD} = V_{OUT} / I_{OUT}$$

- 3) Calculate the output current that would exist for each  $R_{LOAD}$  data point in a nonpositioned application:

$$I_{NP} = V_{NP} / R_{LOAD}$$

where  $V_{NP} = 1.6V$  (in this example).

- 4) Calculate effective efficiency as:

Effective efficiency =  $(V_{NP} \times I_{NP}) / (V_{IN} \times I_{IN})$  = calculated nonpositioned power output divided by the measured voltage-positioned power input.

- 5) Plot the efficiency data point at the nonpositioned current,  $I_{NP}$ .

The effective efficiency of voltage-positioned circuits is shown in the *Typical Operating Characteristics*.

## Dropout Performance

The output-voltage adjustable range for continuous-conduction operation is restricted by the nonadjustable 500ns (max) minimum off-time one-shot. For best dropout performance, use the slower (200kHz) on-time settings. When working with low input voltages, the duty-factor limit must be calculated using worst-case values for on- and off-times. Manufacturing tolerances and internal propagation delays introduce an error to the TON K-factor. This error is greater at higher frequencies (Table 3). Also, keep in mind that transient response performance of buck regulators operated close to dropout is poor, and bulk output capacitance must often be added (see the  $V_{SAG}$  equation in the *Design Procedure* section).

The absolute point of dropout is when the inductor current ramps down during the minimum off-time ( $\Delta I_{DOWN}$ ) as much as it ramps up during the on-time ( $\Delta I_{UP}$ ). The ratio  $h = \Delta I_{UP} / \Delta I_{DOWN}$  is an indicator of ability to slew the inductor current higher in response to increased load and must always be  $>1$ . As  $h$  approaches 1, the absolute minimum dropout point, the inductor current cannot increase as much during each switching cycle, and  $V_{SAG}$  greatly increases unless additional output capacitance is used.

A reasonable minimum value for  $h$  is 1.5, but adjusting this up or down allows trade-offs between  $V_{SAG}$ , output capacitance, and minimum operating voltage. For a given value of  $h$ , the minimum operating voltage can be calculated as:

$$V_{IN(MIN)} = \left[ \frac{V_{OUT} + V_{DROP1}}{1 - \left( \frac{t_{OFF(MIN)}h}{K} \right)} \right] + V_{DROP2} - V_{DROP1}$$

where  $V_{DROP1}$  and  $V_{DROP2}$  are the parasitic voltage drops in the discharge and charge paths (see *On-Time One-Shot*),  $t_{OFF(MIN)}$  is from the *Electrical Characteristics* table, and  $K$  is taken from Table 3. The absolute minimum input voltage is calculated with  $h = 1$ .

If the calculated  $V_{IN(MIN)}$  is greater than the required minimum input voltage, then reduce the operating frequency or add output capacitance to obtain an acceptable  $V_{SAG}$ . If operation near dropout is anticipated, calculate  $V_{SAG}$  to be sure of adequate transient response.

## Dropout Design Example:

$$V_{OUT} = 1.6V$$

$$f_{SW} = 550kHz$$

$$K = 1.8\mu s, \text{ worst-case } K = 1.58\mu s$$

$$t_{OFF(MIN)} = 500ns$$

$$V_{DROP1} = V_{DROP2} = 100mV$$

$$h = 1.5$$

$$V_{IN(MIN)} = [(1.6V + 0.1V) / (1 - (0.5\mu s \times 1.5 / 1.58\mu s))] + 0.1V - 0.1V = 3.2V$$

Calculating again with  $h = 1$  gives the absolute limit of dropout:

$$V_{IN(MIN)} = [(1.6V + 0.1V) / (1 - (0.5\mu s \times 1.0 / 1.58\mu s))] + 0.1V - 0.1V = 2.5V$$

Therefore,  $V_{IN}$  must be greater than 2.5V, even with very large output capacitance, and a practical input voltage with reasonable output capacitance would be 3.2V.

## Adjusting $V_{OUT}$ with a Resistive Divider

The output voltage can be adjusted with a resistive-divider rather than the DAC if desired (Figure 9). The drawback is that the on-time doesn't automatically receive correct compensation for changing output voltage levels. This can result in variable switching frequency as the resistor ratio is changed, and/or excessive switching frequency. The equation for adjusting the output voltage is:

$$V_{OUT} = V_{FB} (1 + R1 / (R2 \parallel R_{INT}))$$

where  $V_{FB}$  is the currently selected DAC value, and  $R_{INT}$  is the FB input resistance. In resistor-adjusted circuits, the DAC code should be set as close as possible to the actual output voltage in order to minimize the shift in switching frequency.

## Adjusting $V_{OUT}$ Above 2V

The feed-forward circuit that makes the on-time dependent on the input voltage maintains a nearly constant switching frequency as  $V+$ ,  $I_{LOAD}$ , and the DAC code are changed. This works extremely well as long as FB is connected directly to the output. When the output is

# High-Speed, Adjustable, Synchronous Step-Down Controllers with Integrated Voltage Positioning

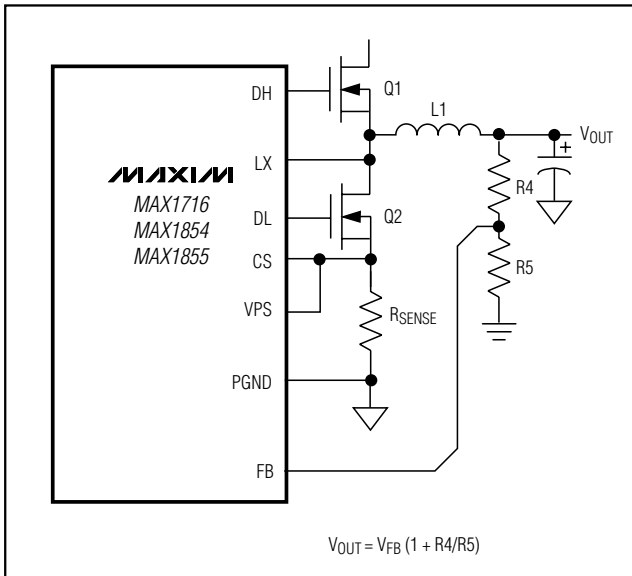

Figure 9. Adjusting  $V_{OUT}$  with a Resistor-Divider

adjusted with a resistor-divider, the switching frequency is increased by the inverse of the divider ratio.

This change in frequency can be compensated with the addition of a resistor-divider to the battery-sense input ( $V+$ ). Attach a resistor-divider from the battery voltage to  $V+$  on the MAX1716/MAX1854/MAX1855, with the same attenuation factor as the output divider. The  $V+$  input has a nominal input impedance of  $600\text{k}\Omega$ , which should be considered when selecting resistor values.

## One-Stage (Battery Input) vs. Two-Stage (5V Input) Applications

The MAX1716/MAX1854/MAX1855 can be used with a direct battery connection (one stage) or can obtain power from a regulated 5V supply (two stage). Each approach has advantages, and careful consideration should go into the selection of the final design.

The one-stage approach offers smaller total inductor size and fewer capacitors overall due to the reduced demands on the 5V supply. The transient response of the single stage is better due to the ability to ramp the inductor current faster. The total efficiency of a single stage is better than the two-stage approach.

The two-stage approach allows flexible placement due to smaller circuit size and reduced local power dissipation. The power supply can be placed closer to the CPU for better regulation and lower  $I^2R$  losses from PC board traces. Although the two-stage design has slow-

er transient response than the single stage, this can be offset by the use of a voltage-positioned converter.

## Ceramic Output Capacitor Applications

Ceramic capacitors have advantages and disadvantages. They have ultra-low ESR and are noncombustible, relatively small, and nonpolarized. However, they are also expensive and brittle, and their ultra-low ESR characteristic can result in excessively high ESR zero frequencies. In addition, their relatively low capacitance value can cause output overshoot when stepping from full-load to no-load conditions, unless a small inductor value is used (high switching frequency), or there are some bulk tantalum or electrolytic capacitors in parallel to absorb the stored inductor energy. In some cases, there may be no room for electrolytics, creating a need for a DC-DC design that uses nothing but ceramics.

The MAX1716 can take full advantage of the small size and low ESR of ceramic output capacitors in a voltage-positioned circuit. The addition of the positioning resistor increases the ripple at FB, lowering the effective ESR zero frequency of the ceramic output capacitor.

Output overshoot ( $V_{SOAR}$ ) determines the minimum output capacitance requirement (see *Output Capacitor Selection*). Often the switching frequency is increased to 400kHz or 550kHz, and the inductor value is reduced to minimize the energy transferred from inductor to capacitor during load-step recovery. The efficiency penalty for operating at 400kHz is about 2% to 3% and about 5% at 550kHz when compared to the 300kHz voltage-positioned circuit, primarily due to the high-side MOSFET switching losses.

Table 1 and the *Typical Operating Characteristics* include a circuit using ceramic capacitors with a 550kHz switching frequency (Figure 13).

## PC Board Layout Guidelines

Careful PC board layout is critical to achieve low switching losses and clean, stable operation. The switching power stage requires particular attention (Figure 10). If possible, mount all of the power components on the top side of the board with their ground terminals flush against one another. Follow these guidelines for good PC board layout:

- 1) Keep the high-current paths short, especially at the ground terminals. This is essential for stable, jitter-free operation.
- 2) Connect all analog grounds to a separate solid copper plane, which connects to the GND pin of the MAX1716/MAX1854/MAX1855. This includes the

# High-Speed, Adjustable, Synchronous Step-Down Controllers with Integrated Voltage Positioning

MAX1716/MAX1854/MAX1855

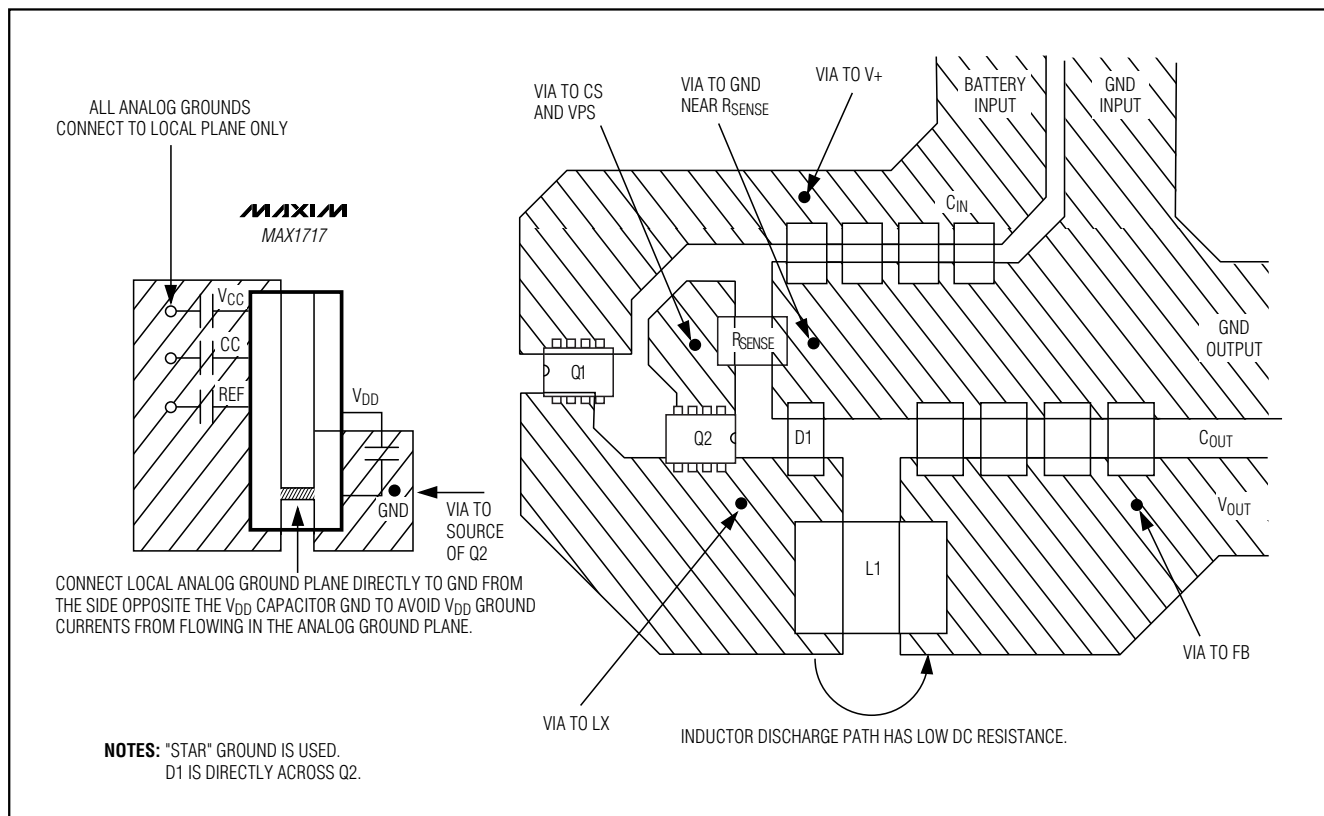

Figure 10. Power-Stage PC Board Layout Example

$V_{CC}$ , REF, and CC capacitors, as well as the resistive-dividers connected to FB and ILIM.

- 3) Keep the power traces and load connections short. This is essential for high efficiency. The use of thick copper PC boards (2oz vs. 1oz) can enhance full-load efficiency by 1% or more. Correctly routing PC board traces is a difficult task that must be approached in terms of fractions of centimeters, where a single mΩ of excess trace resistance causes a measurable efficiency penalty.
- 4) CS and PGND connections for current limiting must be made using Kelvin sense connections to guarantee the current-limit accuracy.
- 5) When trade-offs in trace lengths must be made, it's preferable to allow the inductor charging path to be made longer than the discharge path. For example, it's better to allow some extra distance between the input capacitors and the high-side MOSFET than to allow distance between the inductor and the low-side

MOSFET or between the inductor and the output filter capacitor.

- 6) Ensure the FB connection to the output is short and direct.
- 7) Route high-speed switching nodes away from sensitive analog areas (CC, REF, ILIM). Make all pin-strap control input connections (SKIP, SHDN, ILIM, etc.) to analog ground or  $V_{CC}$  rather than PGND or  $V_{DD}$ .

### Layout Procedure

- 1) Place the power components first, with ground terminals adjacent (low-side MOSFET source,  $C_{IN}$ ,  $C_{OUT}$ , and D1 anode). If possible, make all these connections on the top layer with wide, copper-filled areas.
- 2) Mount the controller IC adjacent to the low-side MOSFET. The DL gate trace must be short and wide, measuring 10 to 20 squares (50mils to 100mils wide if the MOSFET is 1 inch from the controller IC).

# High-Speed, Adjustable, Synchronous Step-Down Controllers with Integrated Voltage Positioning

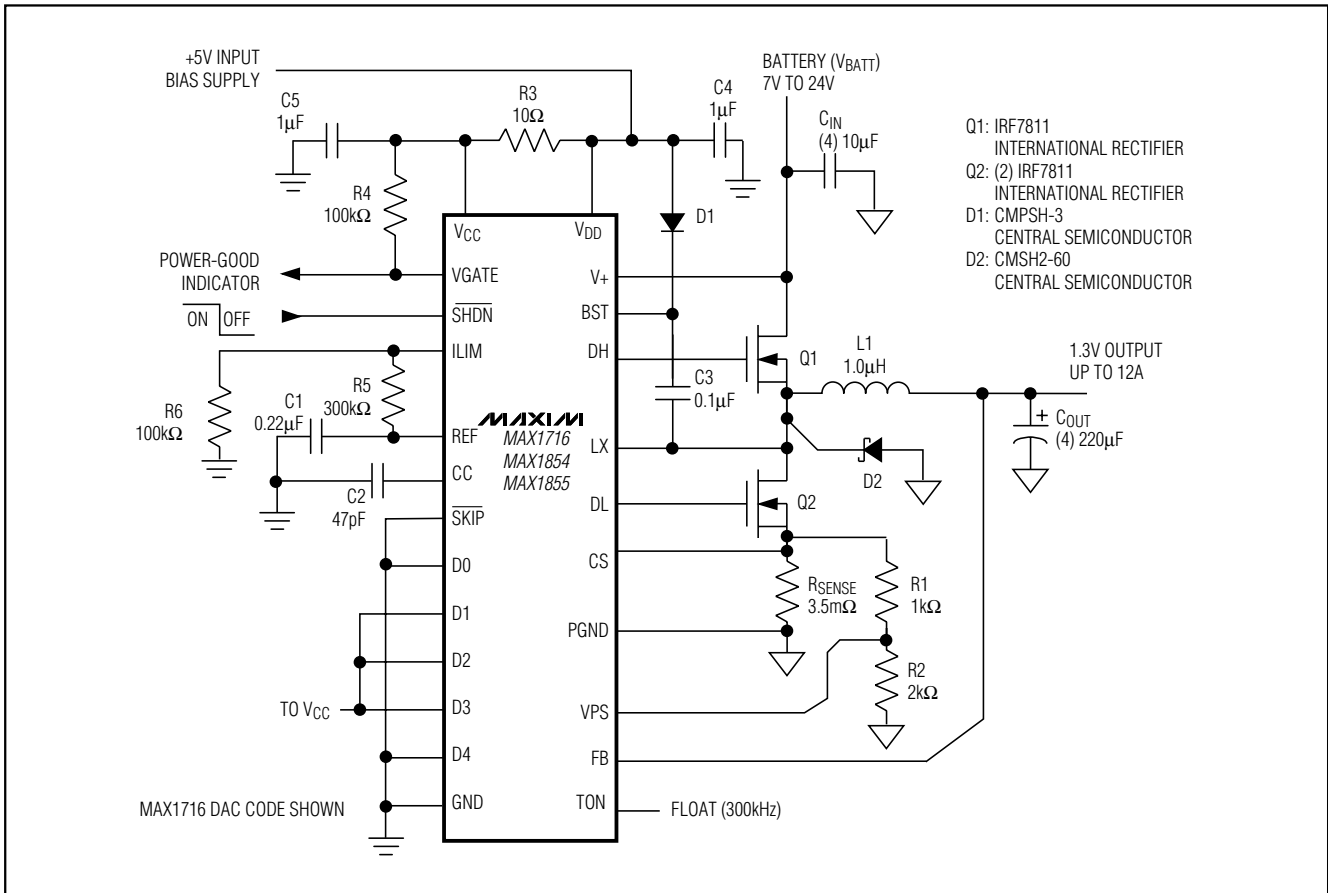

Figure 11. Low-Current Application (Circuit #2)

- 3) Group the gate-drive components (BST diode and capacitor,  $V_{DD}$  bypass capacitor) together near the controller IC.
- 4) Make the DC-DC controller ground connections as shown in Figure 1. This diagram can be viewed as having three separate ground planes: output ground, where all the high-power components go; the GND plane, where the GND pin and  $V_{DD}$  bypass capacitors go; and an analog ground plane where sensitive analog components go. The analog ground plane and GND plane must meet only at a single point directly beneath the IC. These two planes are then connected to the high-power output ground with a short connection from GND to the source of the low-side MOSFET (the middle of the star ground). This

point must also be very close to the output capacitor ground terminal.

- 5) Connect the output power planes ( $V_{CORE}$  and system ground planes) directly to the output filter capacitor positive and negative terminals with multiple vias. Place the entire DC-DC converter circuit as close to the CPU as is practical.

## Chip Information

TRANSISTOR COUNT: 3729

# High-Speed, Adjustable, Synchronous Step-Down Controllers with Integrated Voltage Positioning

MAX1716/MAX1854/MAX1855

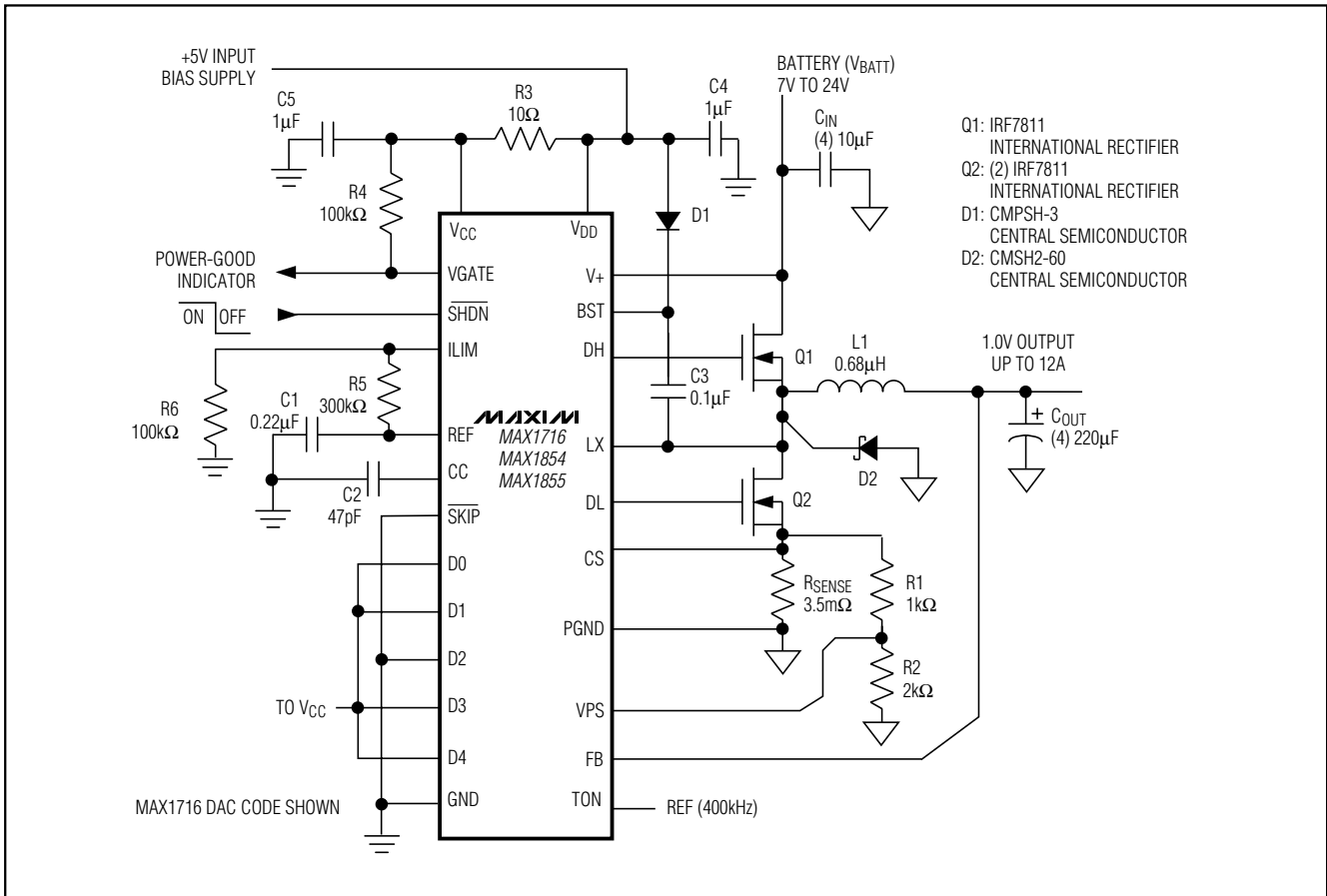
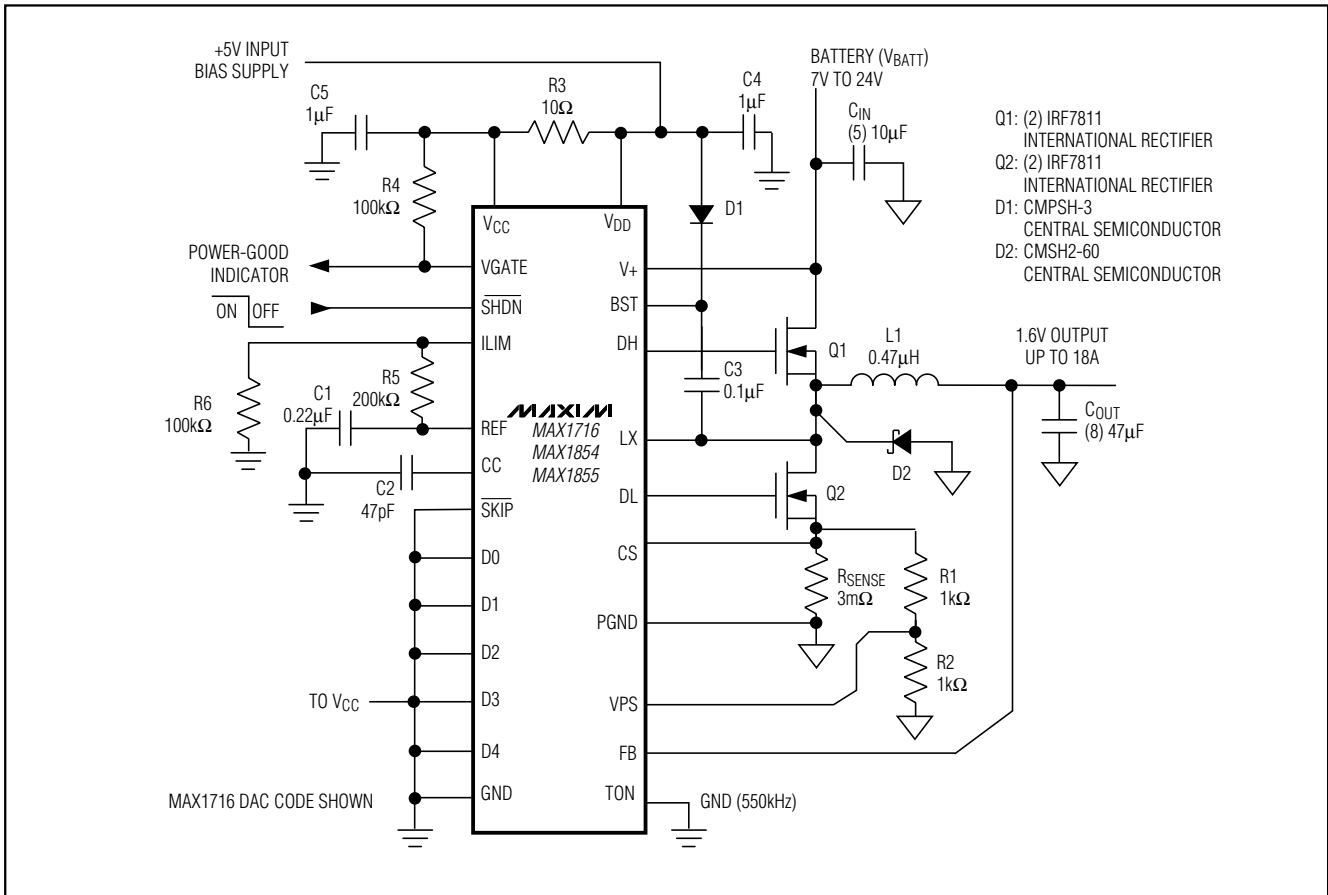
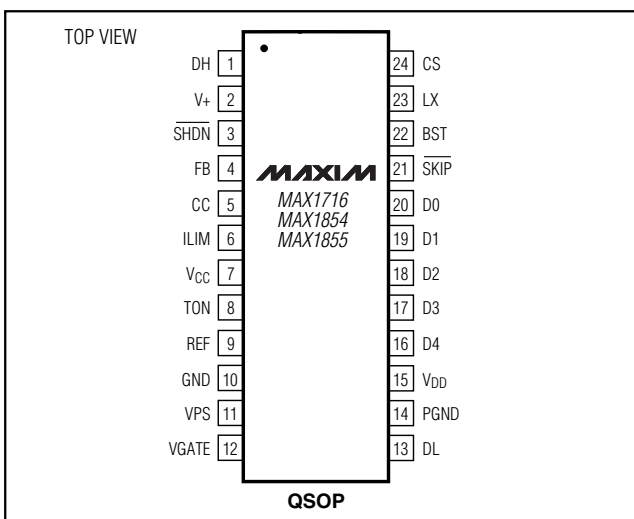

Figure 12. Low-Voltage Application (Circuit #3)

# High-Speed, Adjustable, Synchronous Step-Down Controllers with Integrated Voltage Positioning



## Pin Configuration



# High-Speed, Adjustable, Synchronous Step-Down Controllers with Integrated Voltage Positioning

## Package Information

MAX1716/MAX1854/MAX1855

QSOP EPSS

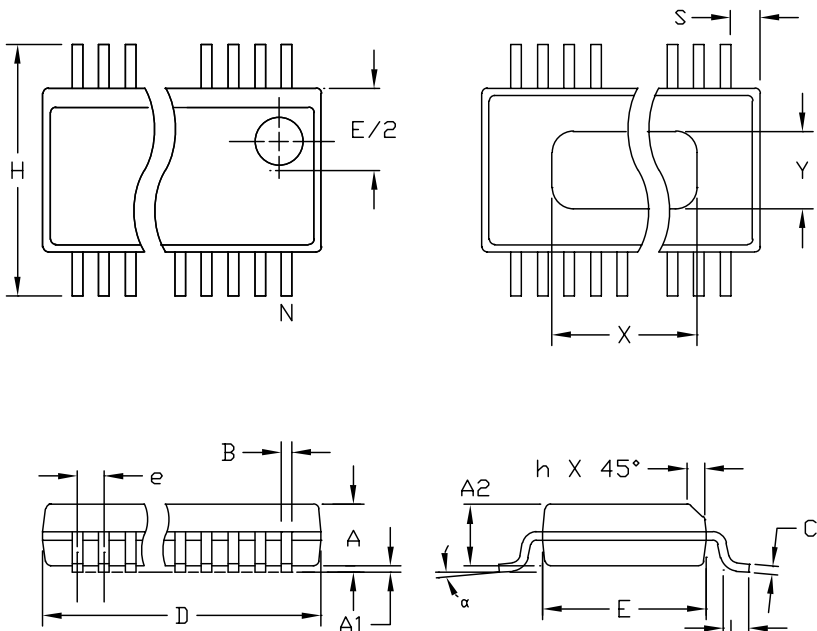

DIM	INCHES		MILLIMETERS	
	MIN	MAX	MIN	MAX
A	.061	.068	1.55	1.73
A1	.004	.0098	0.102	0.249
A2	.055	.061	1.40	1.55
B	.008	.012	0.20	0.31
C	.0075	.0098	0.191	0.249
D	SEE VARIATIONS			
E	.150	.157	3.81	3.99
e	.025 BSC		0.635 BSC	
H	.230	.244	5.84	6.20
h	.010	.016	0.25	0.41
L	.016	.035	0.41	0.89
N	SEE VARIATIONS			
X	SEE VARIATIONS			
Y	.071	.087	1.803	2.209
α	0°	8°	0°	8°

### VARIATIONS:

DIM	INCHES		MILLIMETERS		N
	MIN	MAX	MIN	MAX	
D	.189	.196	4.80	4.98	16 AA
S	.0020	.0070	0.05	0.18	
X	.107	.123	2.72	3.12	
D	.337	.344	8.56	8.74	20 AB
S	.0500	.0550	1.270	1.397	
D	.337	.344	8.56	8.74	24 AC
S	.0250	.0300	0.635	0.762	
D	.386	.393	9.80	9.98	28 AD
S	.0250	.0300	0.635	0.762	
X	.271	.287	6.88	7.29	

### NOTES:

1. D & E DO NOT INCLUDE MOLD FLASH OR PROTRUSIONS
2. MOLD FLASH OR PROTRUSIONS NOT TO EXCEED .006" PER SIDE.
3. HEAT SLUG DIMENSIONS X AND Y APPLY ONLY TO 16 AND 28 LEAD POWER-QSOP PACKAGES.
4. CONTROLLING DIMENSIONS: INCHES.

<b>MAXIM</b>			
PROPRIETARY INFORMATION			
TITLE:			
PACKAGE OUTLINE, QSOP, .150", .025" LEAD PITCH			
APPROVAL	DOCUMENT CONTROL NO.	REV	1/1
	21-0055	B	

Maxim cannot assume responsibility for use of any circuitry other than circuitry entirely embodied in a Maxim product. No circuit patent licenses are implied. Maxim reserves the right to change the circuitry and specifications without notice at any time.

33 **Maxim Integrated Products, 120 San Gabriel Drive, Sunnyvale, CA 94086 408-737-7600**

## Looking for pricing, stock, or lifecycle information?

Click below to explore more details on WIN SOURCE:

 [View MAX1716EEG+ on WIN SOURCE](#)

 [Maxim Integrated](#) Information

## Optimize Your Supply Chain with WIN SOURCE Solutions

-  Global Sourcing Solution
-  Obsolete Management
-  Cost Control Management
-  Shortage Management
-  Alternative Solution
-  Excess Inventory Management