



**THE DATASHEET OF
MAX3093EEPE+**





±15kV ESD-Protected, 10Mbps, 3V/5V, Low-Power Quad RS-422/RS-485 Receivers

General Description

The MAX3093E/MAX3094E are rugged, low-power, quad, RS-422/RS-485 receivers featuring electrostatic discharge (ESD) protection for use in harsh environments. All receiver inputs are protected to ±15kV using IEC 1000-4-2 Air-Gap Discharge, ±8kV using IEC 1000-4-2 Contact Discharge, and ±15kV using the Human Body Model. The MAX3093E operates from a +5V supply, while the MAX3094E operates from a +3.3V supply. Receiver propagation delays are guaranteed to within ±8ns of a predetermined value, thereby ensuring device-to-device matching across production lots.

The devices feature a 1nA low-power shutdown mode in which the receiver outputs are high impedance. When active, these receivers have a fail-safe feature that guarantees a logic-high output if the input is open circuit. They also have a quarter-unit-load input impedance that allows 128 receivers on a bus.

The MAX3093E/MAX3094E are pin-compatible, low-power upgrades to the industry-standard '34C86. They are available in space-saving TSSOP, narrow SO, and PDIP packages.

Applications

Telecommunications Equipment
Rugged RS-422/RS-485/RS-423 Bus Receiver
Receivers for ESD-Sensitive Applications
Level Translators

Functional Diagram

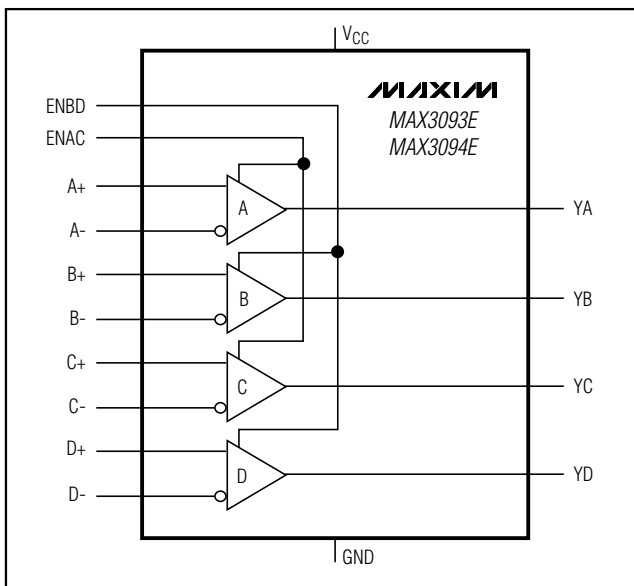

Features

- ◆ ESD Protection
 - ±15kV—IEC 1000-4-2 Air-Gap Discharge
 - ±8kV—IEC 1000-4-2 Contact Discharge
 - ±15kV—Human Body Model
- ◆ Guaranteed Propagation-Delay Tolerance Between All ICs
 - ±8ns (MAX3093E)
 - ±10ns (MAX3094E)
- ◆ Single +3V Operation (MAX3094E)
Single +5V Operation (MAX3093E)
- ◆ 16-Pin TSSOP
- ◆ 10Mbps Data Rate
- ◆ Allow up to 128 Receivers on the Bus
- ◆ 1nA Low-Power Shutdown Mode
- ◆ 2.4mA Operating Supply Current
- ◆ Pin-Compatible Upgrades to '34C86

Ordering Information

PART	TEMP RANGE	PIN-PACKAGE
MAX3093ECUE	0°C to +70°C	16 TSSOP
MAX3093ECSE	0°C to +70°C	16 Narrow SO
MAX3093ECEPE	0°C to +70°C	16 Plastic DIP
MAX3093EEUE	-40°C to +85°C	16 TSSOP
MAX3093EESE	-40°C to +85°C	16 Narrow SO
MAX3093EEPE	-40°C to +85°C	16 Plastic DIP
MAX3094ECUE	0°C to +70°C	16 TSSOP
MAX3094ECSE	0°C to +70°C	16 Narrow SO
MAX3094ECEPE	0°C to +70°C	16 Plastic DIP
MAX3094EEUE	-40°C to +85°C	16 TSSOP
MAX3094EESE	-40°C to +85°C	16 Narrow SO
MAX3094EEPE	-40°C to +85°C	16 Plastic DIP

Pin Configuration

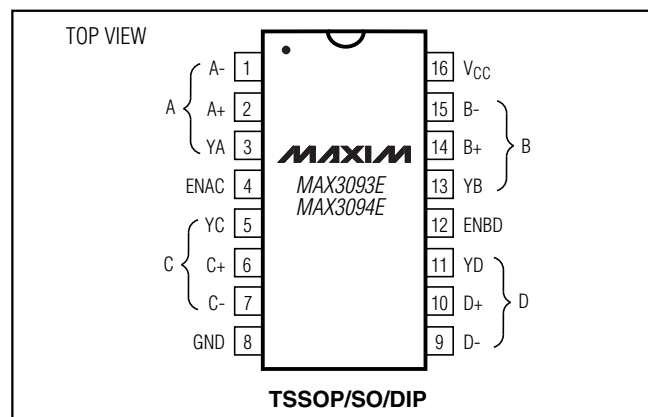

±15kV ESD-Protected, 10Mbps, 3V/5V, Low-Power Quad RS-422/RS-485 Receivers

ABSOLUTE MAXIMUM RATINGS

Supply Voltage (V _{CC})	+7V
Control Input Voltage (ENAC, ENBD)	-0.3V to (V _{CC} + 0.3V)
Receiver Input Voltage (I ₊ , I ₋)	±25V
Receiver Output Voltage (Y ₋)	-0.3V to (V _{CC} + 0.3V)
Output Short-Circuit Duration (Y ₋ , one output)	Continuous
Continuous Power Dissipation (T _A = +70°C)	
TSSOP (derate 9.4mW/°C above +70°C)	755mW
SO (derate 8.7mW/°C above +70°C)	696mW
Plastic DIP (derate 10.5mW/°C above +70°C)	762mW

Operating Temperature Ranges

MAX309_EC_	0°C to +70°C
MAX309_EE_	-40°C to +85°C
Junction Temperature	+150°C
Storage Temperature Range	-65°C to +160°C
Lead Temperature (soldering, 10s)	+300°C

Stresses beyond those listed under "Absolute Maximum Ratings" may cause permanent damage to the device. These are stress ratings only, and functional operation of the device at these or any other conditions beyond those indicated in the operational sections of the specifications is not implied. Exposure to absolute maximum rating conditions for extended periods may affect device reliability.

DC ELECTRICAL CHARACTERISTICS—MAX3093E

(V_{CC} = +5V ±5%, T_A = T_{MIN} to T_{MAX}, unless otherwise noted. Typical values are at V_{CC} = +5.0V, T_A = +25°C.) (Note 1)

PARAMETER	SYMBOL	CONDITIONS	MIN	TYP	MAX	UNITS
Receiver Differential Input Threshold	V _{TH}	-7V ≤ V _{CM} ≤ 12V	-200		200	mV
Receiver Input Hysteresis		V _{CM} = 0		45		mV
Receiver Input Current (I ₊ , I ₋)	I _{IN}	V _{CC} = 0 or 5.25V		V _{IN} = 12V V _{IN} = -7V	250 -200	μA
Enable Input Current (ENAC/ENBD)					±1	μA
Enable Input High Voltage (ENAC/ENBD)	V _{IH}		2.0			V
Enable Input Low Voltage (ENAC/ENBD)	V _{IL}				0.8	V
Receiver Output High Voltage	V _{OH}	I _{OUT} = -4mA, V _{ID} = 200mV, output enabled, Figure 1	V _{CC} - 1.5			V
Receiver Output Low Voltage	V _{OL}	I _{OUT} = 4mA, V _{ID} = -200mV, output enabled, Figure 1			0.4	V
Three-State Current at Receiver Output	I _{OZR}	0 ≤ V _{OUT} ≤ V _{CC} , output disabled			±1	μA
Output Short-Circuit Current	I _{OSR}	0 ≤ V _{OUT} ≤ V _{CC} , output enabled	±7		±75	mA
Receiver Input Resistance	R _{IN}	-7V ≤ V _{CM} ≤ 12V	48			kΩ
Supply Current	I _{CC}	No load, output enabled		2.4	3.5	mA
		Output disabled		0.001	10	μA
ESD Protection (Note 2)		Human Body Model		±15		kV
		IE C1000-4-2 Air-Gap Discharge		±15		
		IE C1000-4-2 Contact Discharge		±8		

±15kV ESD-Protected, 10Mbps, 3V/5V, Low-Power Quad RS-422/RS-485 Receivers

MAX3093E/MAX3094E

SWITCHING CHARACTERISTICS—MAX3093E

(V_{CC} = +5V ±5%, T_A = T_{MIN} to T_{MAX}, unless otherwise noted. Typical values are at V_{CC} = +5.0V, T_A = +25°C.)

PARAMETER	SYMBOL	CONDITIONS		MIN	TYP	MAX	UNITS	
Input-to-Output Propagation Delay	t _{PLH} , t _{PHL}	V _{ID} = 3V, Figure 2	V _{CC} = +5V ±5%, T _A = T _{MIN} to T _{MAX}	65		98	ns	
			V _{CC} = 5.25V	T _A = +85°C	78	86		94
				T _A = +70°C	76			92
				T _A = +25°C	71	79		87
				T _A = -40°C	65	73		81
			V _{CC} = 4.75V	T _A = +85°C	82	90		98
				T _A = +70°C	80			96
				T _A = +25°C	74	82		90
T _A = -40°C	68	76		84				
Device-to-Device Propagation-Delay Matching		V _{ID} = 3V, Figure 2, matched conditions				16	ns	
Propagation-Delay Skew (t _{PLH} - t _{PHL})	t _{SK}	Figure 2			-2	±10	ns	
Output Enable Time to Low Level	t _{ZL}	Figure 3			600	800	ns	
Output Enable Time to High Level	t _{ZH}	Figure 3			600	800	ns	
Output Disable Time from Low Level	t _{LZ}	Figure 3			60	100	ns	
Output Disable Time from High Level	t _{HZ}	Figure 3			60	100	ns	
Maximum Data Rate	f _{MAX}			10			Mbps	

DC ELECTRICAL CHARACTERISTICS—MAX3094E

(V_{CC} = +3.0V to +3.6V, T_A = T_{MIN} to T_{MAX}, unless otherwise noted. Typical values are at V_{CC} = +3.3V, T_A = +25°C.) (Note 1)

PARAMETER	SYMBOL	CONDITIONS		MIN	TYP	MAX	UNITS
Receiver Differential Input Threshold	V _{TH}	-7V ≤ V _{CM} ≤ 12V		-200		200	mV
Receiver Input Hysteresis		V _{CM} = 0			45		mV
Receiver Input Current (I ₊ , I ₋)	I _{IN}	V _{CC} = 0 or 3.6V	V _{IN} = 12V			250	μA
			V _{IN} = -7V			-200	
Enable Input Current (ENAC/ENBD)						±1	μA
Enable Input High Voltage (ENAC/ENBD)	V _{IH}			2.0			V
Enable Input Low Voltage (ENAC/ENBD)	V _{IL}					0.8	V
Receiver Output High Voltage	V _{OH}	I _{OUT} = -1.5mA, V _{ID} = 200mV, output enabled, Figure 1		V _{CC} - 0.4			V

±15kV ESD-Protected, 10Mbps, 3V/5V, Low-Power Quad RS-422/RS-485 Receivers

DC ELECTRICAL CHARACTERISTICS—MAX3094E (continued)

($V_{CC} = +3.0V$ to $+3.6V$, $T_A = T_{MIN}$ to T_{MAX} , unless otherwise noted. Typical values are at $V_{CC} = +3.3V$, $T_A = +25^\circ C$.) (Note 1)

PARAMETER	SYMBOL	CONDITIONS	MIN	TYP	MAX	UNITS
Receiver Output Low Voltage	V_{OL}	$I_{OUT} = 2.5mA$, $V_{ID} = -200mV$, output enabled, Figure 1			0.4	V
Three-State Current at Receiver Output	I_{OZR}	$0 \leq V_{OUT} \leq V_{CC}$, output disabled			±1	µA
Output Short-Circuit Current	I_{OSR}	$0 \leq V_{OUT} \leq V_{CC}$, output enabled	±4		±60	mA
Receiver Input Resistance	R_{IN}	$-7V \leq V_{CM} \leq 12V$	48			kΩ
Supply Current	I_{CC}	No load, outputs enabled		2.4	4.0	mA
		Outputs disabled		0.001	10	µA
ESD Protection (Note 2)		Human Body Model		±15		kV
		IEC 1000-4-2 Air-Gap Discharge		±15		
		IEC 1000-4-2 Contact Discharge		±8		

SWITCHING CHARACTERISTICS—MAX3094E

($V_{CC} = +3.0V$ to $+3.6V$, $T_A = T_{MIN}$ to T_{MAX} , unless otherwise noted. Typical values are at $V_{CC} = +3.3V$, $T_A = +25^\circ C$.)

PARAMETER	SYMBOL	CONDITIONS	MIN	TYP	MAX	UNITS		
Input-to-Output Propagation Delay	t_{PLH} , t_{PHL}	$ V_{ID} = 3V$, Figure 2	$V_{CC} = +3.3V \pm 5\%$, $T_A = T_{MIN}$ to T_{MAX}			69	123	ns
				$V_{CC} = 3.60V$	$T_A = +85^\circ C$	88	98	
			$T_A = +70^\circ C$		86		106	
			$V_{CC} = 3.00V$	$T_A = +25^\circ C$	78	88	98	
		$T_A = -40^\circ C$		69	79	89		
		$T_A = +85^\circ C$		103	113	123		
		$T_A = +70^\circ C$		100		120		
					$T_A = +25^\circ C$	91	101	
$T_A = -40^\circ C$	82				92	102		
Device-to-Device Propagation-Delay Matching		$ V_{ID} = 3V$, Figure 2, matched conditions			20	ns		
Propagation-Delay Skew ($t_{PLH} - t_{PHL}$)	t_{SK}	Figure 2		-1	±10	ns		
Output Enable Time to Low Level	t_{ZL}	Figure 3		600	1000	ns		
Output Enable Time to High Level	t_{ZH}	Figure 3		600	1000	ns		
Output Disable Time from Low Level	t_{LZ}	Figure 3		80	180	ns		
Output Disable Time from High Level	t_{HZ}	Figure 3		80	180	ns		
Maximum Data Rate	f_{MAX}		10			Mbps		

Note 1: All currents into the device are positive; all currents out of the device are negative. All voltages are referred to device ground, unless otherwise noted.

Note 2: Receiver inputs ($_+$, $_-$).

±15kV ESD-Protected, 10Mbps, 3V/5V, Low-Power Quad RS-422/RS-485 Receivers

Typical Operating Characteristics

($V_{CC} = +5V$ for MAX3093E, $V_{CC} = +3.3V$ for MAX3094E, $T_A = +25^\circ C$, unless otherwise noted.)

MAX3093E/MAX3094E

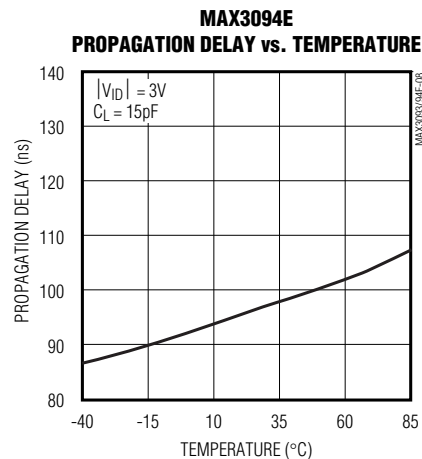
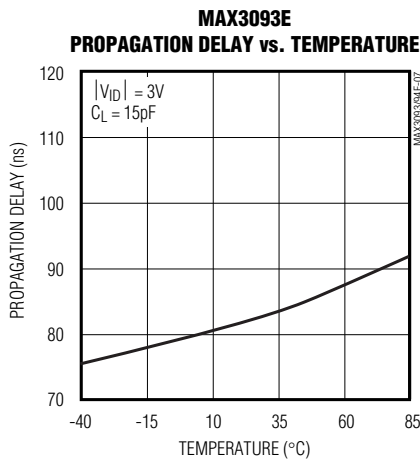
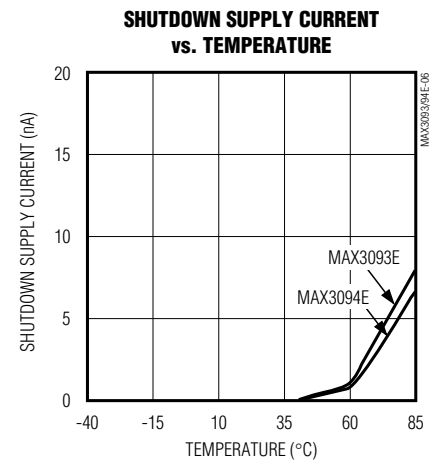
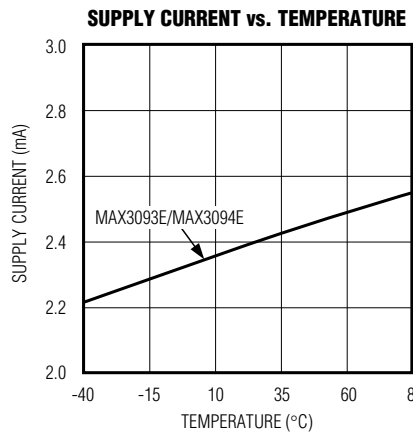
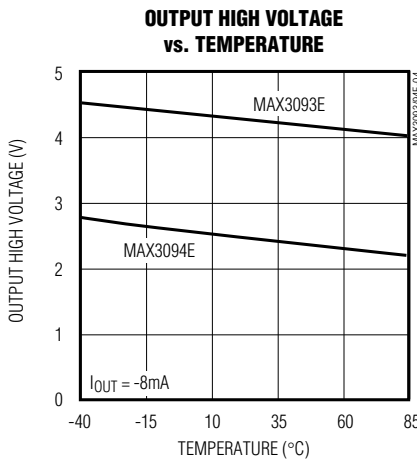
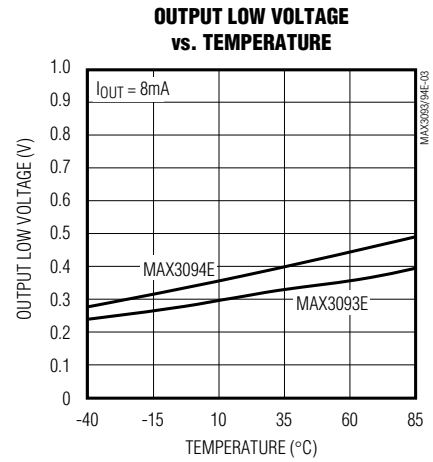
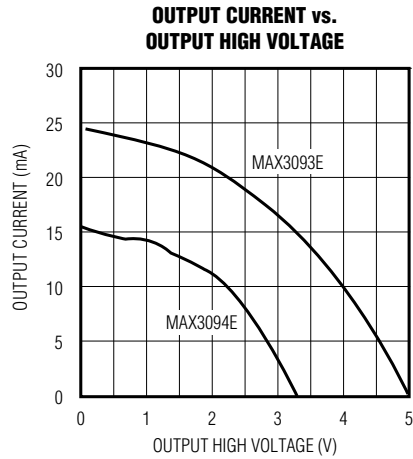
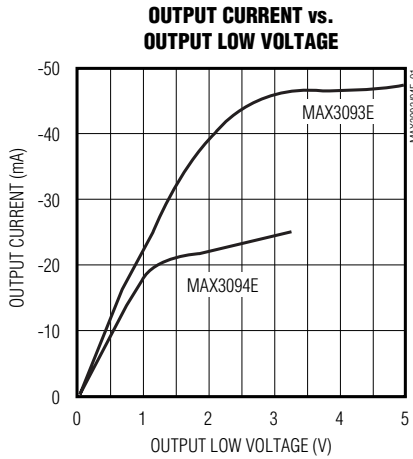

±15kV ESD-Protected, 10Mbps, 3V/5V, Low-Power Quad RS-422/RS-485 Receivers

Typical Operating Characteristics (continued)

(V_{CC} = +5V for MAX3093E, V_{CC} = +3.3V for MAX3094E, T_A = +25°C, unless otherwise noted.)

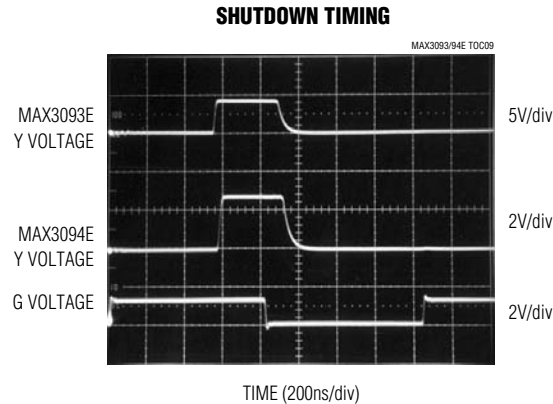

CIRCUIT OF FIGURE 3,
S1 OPEN, S2 CLOSED, S3 = 1V

Pin Description

PIN	NAME	FUNCTION
1	A-	Inverting Receiver A Input
2	A+	Noninverting Receiver A Input
3	YA	Receiver A Output. Enabled when ENAC = high. YA will be logic high if A+ > A- by 200mV, and low if A+ < A- by 200mV. It will be logic high if A+ and A- remain floating. Otherwise, the state is undetermined. YA goes high impedance when ENAC = low.
4	ENAC	Receiver Output A and C Enable High. A logic high on this input enables receivers A and C.
5	YC	Receiver C Output. Same functionality as YA.
6	C+	Noninverting Receiver C Input
7	C-	Inverting Receiver C Input
8	GND	Ground
9	D-	Inverting Receiver D Input
10	D+	Noninverting Receiver D Input
11	YD	Receiver D Output. Enabled when ENBD = high. YD will be logic high if D+ > D- by 200mV, and low if D+ < D- by 200mV. It will be a logic high if D+ and D- remain floating. Otherwise, the state is undetermined. YD goes high impedance when ENBD = low.
12	ENBD	Receiver Output B and D Enable High. A logic high on this input enables receivers B and D.
13	YB	Receiver B Output. Same functionality as YD.
14	B+	Noninverting Receiver B Input
15	B-	Inverting Receiver B Input
16	V _{CC}	Positive Supply

±15kV ESD-Protected, 10Mbps, 3V/5V, Low-Power Quad RS-422/RS-485 Receivers

MAX3093E/MAX3094E

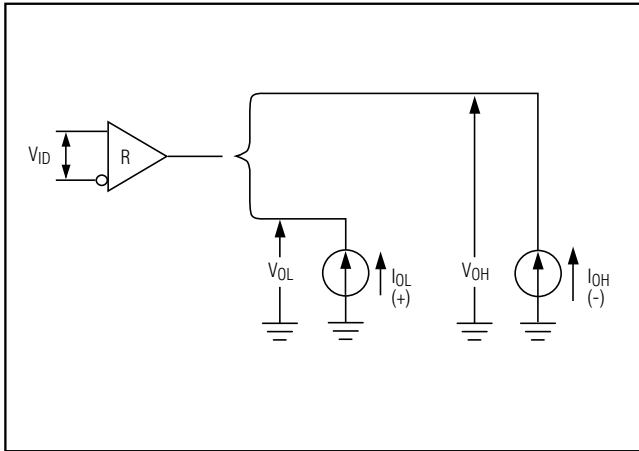

Figure 1. Receiver V_{OH} and V_{OL}

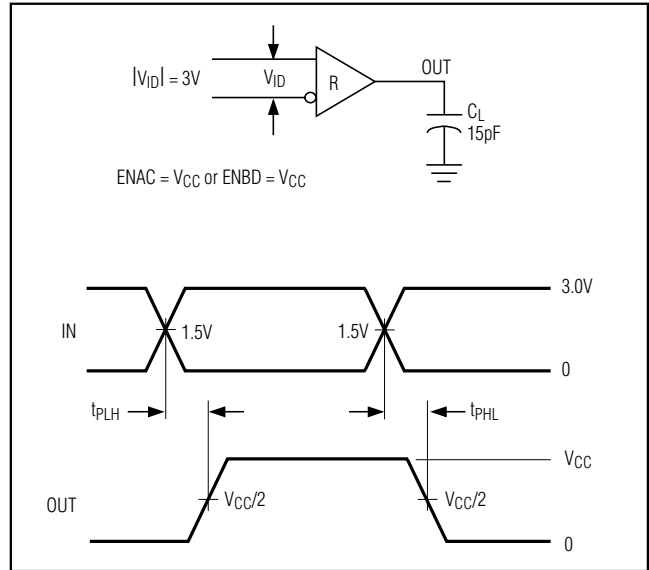

Figure 2. Receiver Propagation Delay

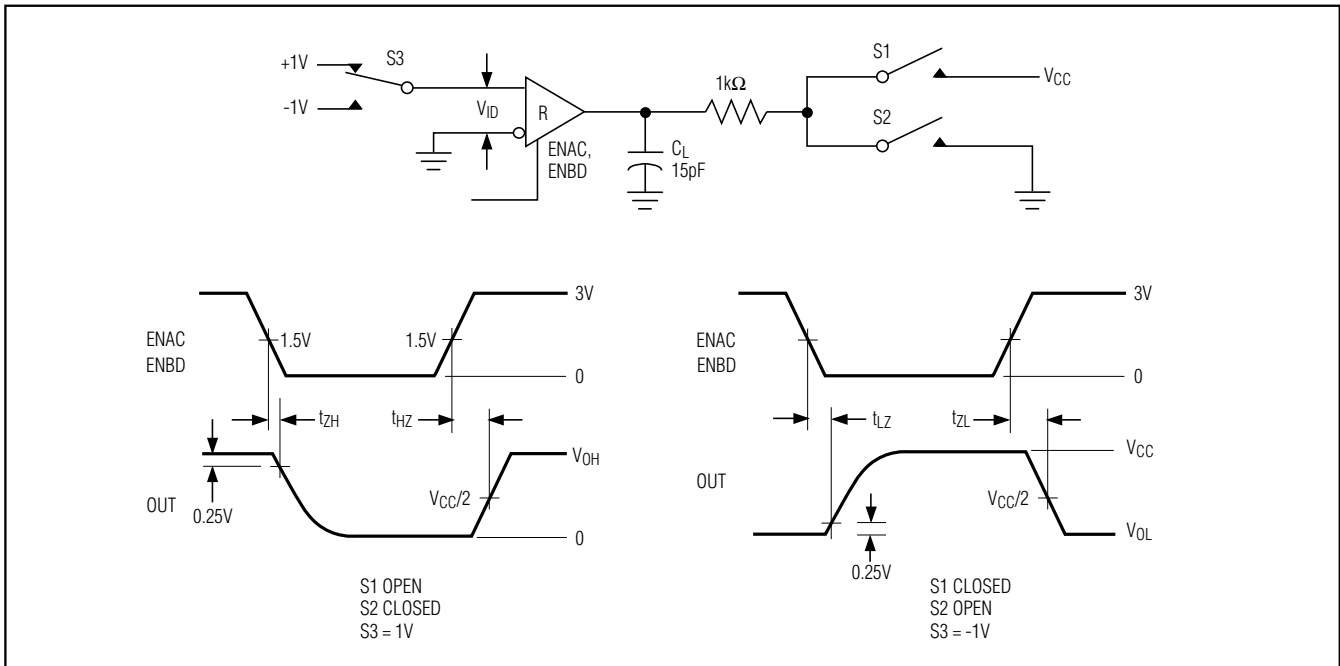

Figure 3. Receiver Enable and Disable Times

±15kV ESD-Protected, 10Mbps, 3V/5V, Low-Power Quad RS-422/RS-485 Receivers

Detailed Description

±15kV ESD Protection

As with all Maxim devices, ESD-protection structures are incorporated on all pins to protect against ESDs encountered during handling and assembly. The MAX3093E/MAX3094E receiver inputs have extra protection against static electricity found in normal operation. Maxim's engineers have developed state-of-the-art structures to protect these pins against ±15kV ESD without damage. After an ESD event, the MAX3093E/MAX3094E continue working without latchup.

ESD protection can be tested in several ways. The receiver inputs are characterized for protection to the following:

- ±15kV using the Human Body Model
- ±8kV using the Contact Discharge Method specified in IEC 1000-4-2 (formerly IEC 801-2)
- ±15kV using the Air-Gap Method specified in IEC 1000-4-2 (formerly IEC 801-2)

ESD Test Conditions

ESD performance depends on a number of conditions. Contact Maxim for a reliability report that documents test setup, methodology, and results.

Human Body Model

Figure 4a shows the Human Body Model, and Figure 4b shows the current waveform it generates when discharged into a low impedance. This model consists of a 100pF capacitor charged to the ESD voltage of interest, which is then discharged into the device through a 1.5kΩ resistor.

IEC 1000-4-2

Since January 1996, all equipment manufactured and/or sold in the European community has been required to meet the stringent IEC 1000-4-2 specification. The IEC 1000-4-2 standard covers ESD testing and performance of finished equipment; it does not specifically refer to integrated circuits. The MAX3093E/MAX3094E help you design equipment that meets Level 4 (the highest level) of IEC 1000-4-2, without additional ESD-protection components.

The main difference between tests done using the Human Body Model and IEC 1000-4-2 is higher peak current in IEC 1000-4-2. Because series resistance is lower in the IEC 1000-4-2 ESD test model (Figure 5a), the ESD-withstand voltage measured to this standard is generally lower than that measured using the Human Body Model. Figure 5b shows the current waveform for the ±8kV IEC 1000-4-2 Level 4 ESD Contact Discharge test. The Air-Gap test involves approaching the device with a charge probe. The Contact-Discharge method connects the probe to the device before the probe is energized.

Machine Model

The Machine Model for ESD testing uses a 200pF storage capacitor and zero-discharge resistance. It mimics the stress caused by handling during manufacturing and assembly. All pins (not just RS-485 inputs) require this protection during manufacturing. Therefore, the Machine Model is less relevant to the I/O ports than are the Human Body Model and IEC 1000-4-2.

Low-Power Shutdown Mode

The function tables show the functionality of the enable inputs. The MAX3093E/MAX3094E enter shutdown when ENAC and ENBD are low. In shutdown, all outputs go high impedance and the devices typically draw less than 1nA. The devices exit shutdown by taking either ENAC or ENBD high. The typical shutdown exit time is 600ns.

Function Tables

ENAC	ENBD	(IN+ - IN-)	OUTPUT YA OR YC	DEVICE MODE
1	X	≥ 200mV	1	On
1	X	≤ -200mV	0	On
1	X	Open	1	On
0	1	X	High-Z	On
0	0	X	High	Shutdown

ENBD	ENAC	(IN+ - IN-)	OUTPUT YB OR YD	DEVICE MODE
1	X	≥ 200mV	1	On
1	X	≤ -200mV	0	On
1	X	Open	1	On
0	1	X	High-Z	On
0	0	X	High-Z	Shutdown

X = don't care, High-Z = high impedance

±15kV ESD-Protected, 10Mbps, 3V/5V, Low-Power Quad RS-422/RS-485 Receivers

MAX3093E/MAX3094E

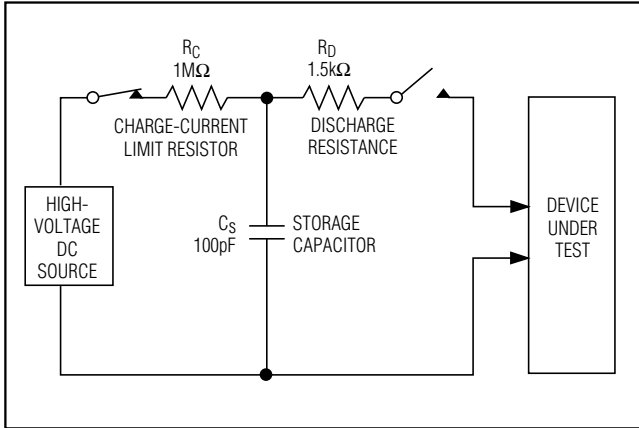

Figure 4a. Human Body ESD Test Model

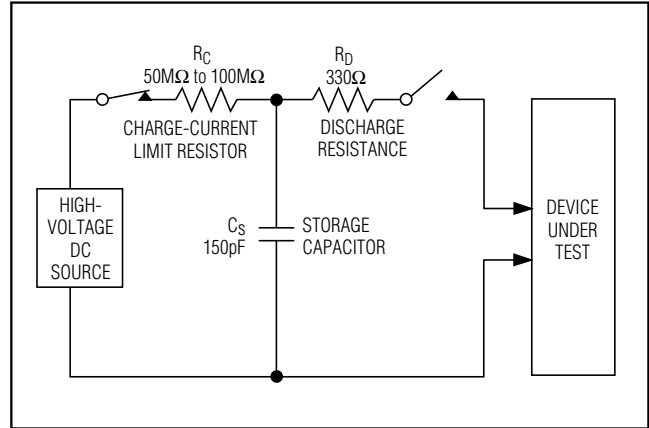

Figure 5a. IEC 1000-4-2 ESD Test Model

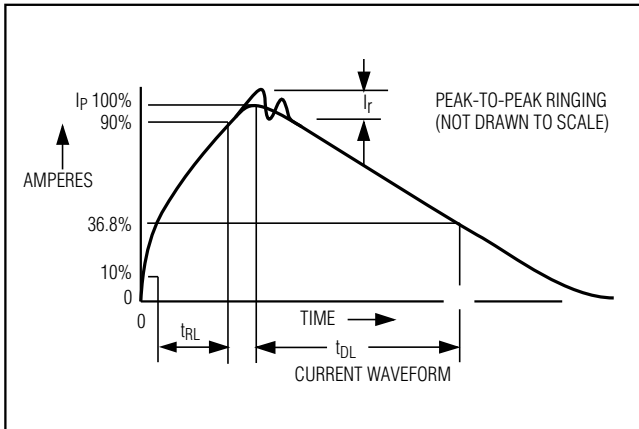

Figure 4b. Human Body Model Current Waveform

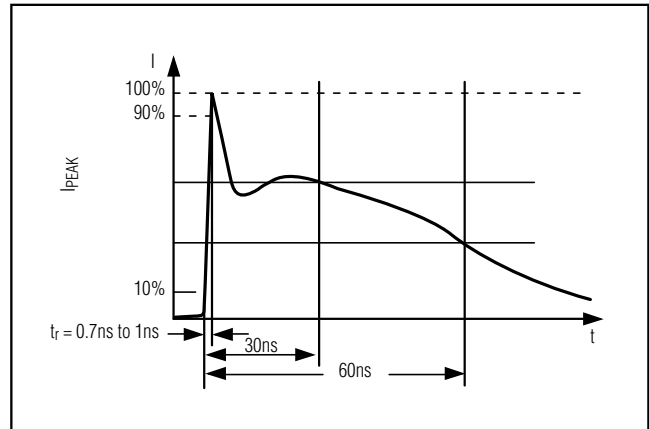

Figure 5b. IEC 1000-4-2 ESD-Generator Current Waveform

±15kV ESD-Protected, 10Mbps, 3V/5V, Low-Power Quad RS-422/RS-485 Receivers

Applications Information

Propagation-Delay Matching

The MAX3093E/MAX3094E exhibit propagation delays that are closely matched from one device to another, even between devices from different production lots. This feature allows multiple data lines to receive data and clock signals with minimal skewing with respect to each other. The MAX3093E receiver propagation delays are trimmed to a predetermined value $\pm 8\text{ns}$, while the MAX3094E delays are trimmed to a predetermined value $\pm 10\text{ns}$.

128 Receivers on the Bus

The standard RS-485 input impedance is $12\text{k}\Omega$ (one-unit load). The standard RS-485 transmitter can drive 32 unit loads. The MAX3093E/MAX3094E present a 1/4-unit-load input impedance ($48\text{k}\Omega$), which allows up to 128 receivers on a bus. Any combination of these RS-485 receivers with a total of 32-unit loads can be connected to the same bus.

Fail-Safe Implementation

The MAX3093E/MAX3094E receiver inputs guarantee a logic high output when the inputs are open circuit (no termination resistor used). This occurs when the transmitter is removed from the bus or when all transmitter outputs are high impedance. However, when the line is terminated and the transmitters are disabled, the differential voltage between the $_+$ and $_-$ inputs falls below the $\pm 200\text{mV}$ RS-485 sensitivity threshold. Consequently, the outputs become undefined. To maintain a fail-safe receiver output while using a terminating resistor, input $_+$ must be biased at least 200mV above input $_-$. The resistor-divider network shown in Figure 6 is recommended.

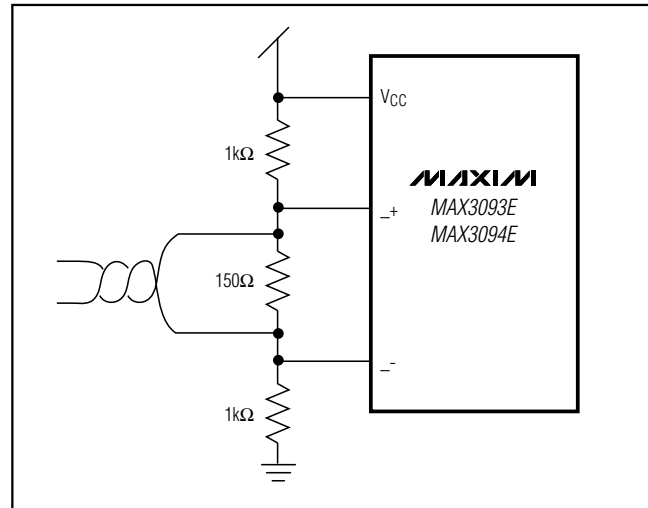

Figure 6. External Fail-Safe Implementation

Chip Information

TRANSISTOR COUNT: 676

±15kV ESD-Protected, 10Mbps, 3V/5V, Low-Power Quad RS-422/RS-485 Receivers

Package Information

(The package drawing(s) in this data sheet may not reflect the most current specifications. For the latest package outline information, go to www.maxim-ic.com/packages.)

MAX3093E/MAX3094E

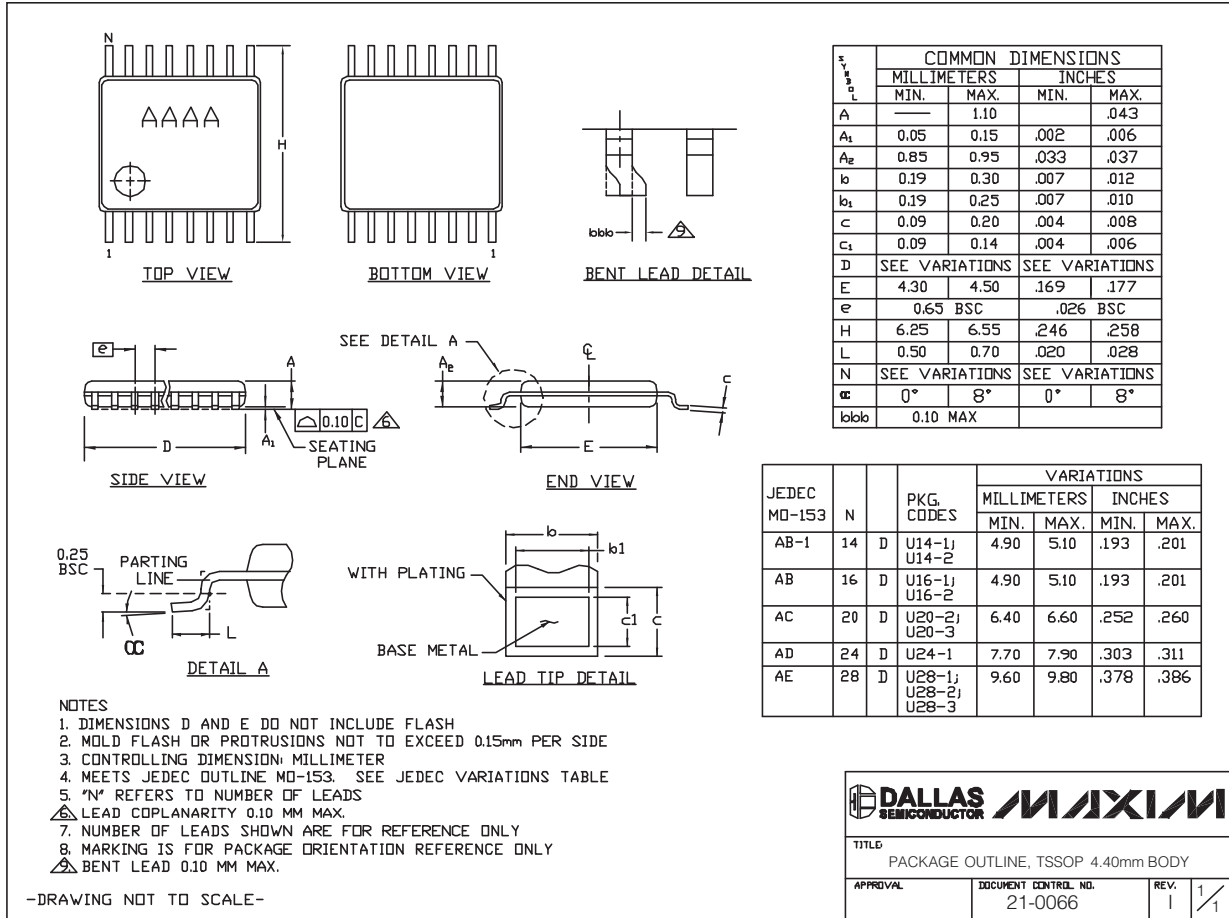

NOTES

1. DIMENSIONS D AND E DO NOT INCLUDE FLASH
2. MOLD FLASH OR PROTRUSIONS NOT TO EXCEED 0.15mm PER SIDE
3. CONTROLLING DIMENSION: MILLIMETER
4. MEETS JEDEC OUTLINE MO-153. SEE JEDEC VARIATIONS TABLE
5. "N" REFERS TO NUMBER OF LEADS
6. LEAD COPLANARITY 0.10 MM MAX.
7. NUMBER OF LEADS SHOWN ARE FOR REFERENCE ONLY
8. MARKING IS FOR PACKAGE ORIENTATION REFERENCE ONLY
9. BENT LEAD 0.10 MM MAX.

-DRAWING NOT TO SCALE-

DALLAS SEMICONDUCTOR	MAXIM
TITLE: PACKAGE OUTLINE, TSSOP 4.40mm BODY	
APPROVAL	DOCUMENT CONTROL NO. 21-0066
REV. 1	1/1

±15kV ESD-Protected, 10Mbps, 3V/5V, Low-Power Quad RS-422/RS-485 Receivers

Package Information (continued)

(The package drawing(s) in this data sheet may not reflect the most current specifications. For the latest package outline information, go to www.maxim-ic.com/packages.)

SOICN .EPS

DIM	INCHES		MILLIMETERS	
	MIN	MAX	MIN	MAX
A	0.053	0.069	1.35	1.75
A1	0.004	0.010	0.10	0.25
B	0.014	0.019	0.35	0.49
C	0.007	0.010	0.19	0.25
e	0.050 BSC		1.27 BSC	
E	0.150	0.157	3.80	4.00
H	0.228	0.244	5.80	6.20
L	0.016	0.050	0.40	1.27

VARIATIONS:

DIM	INCHES		MILLIMETERS		N	MS012
	MIN	MAX	MIN	MAX		
D	0.189	0.197	4.80	5.00	8	AA
D	0.337	0.344	8.55	8.75	14	AB
D	0.386	0.394	9.80	10.00	16	AC

NOTES:

- D&E DO NOT INCLUDE MOLD FLASH.
- MOLD FLASH OR PROTRUSIONS NOT TO EXCEED 0.15mm (.006").
- LEADS TO BE COPLANAR WITHIN 0.10mm (.004").
- CONTROLLING DIMENSION: MILLIMETERS.
- MEETS JEDEC MS012.
- N = NUMBER OF PINS.

DALLAS SEMICONDUCTOR **MAXIM**

PROPRIETARY INFORMATION

TITLE:
PACKAGE OUTLINE, .150" SOIC

APPROVAL	DOCUMENT CONTROL NO. 21-0041	REV: B 1/1
----------	---------------------------------	------------

±15kV ESD-Protected, 10Mbps, 3V/5V, Low-Power Quad RS-422/RS-485 Receivers

Package Information (continued)

(The package drawing(s) in this data sheet may not reflect the most current specifications. For the latest package outline information, go to www.maxim-ic.com/packages.)

MAX3093E/MAX3094E

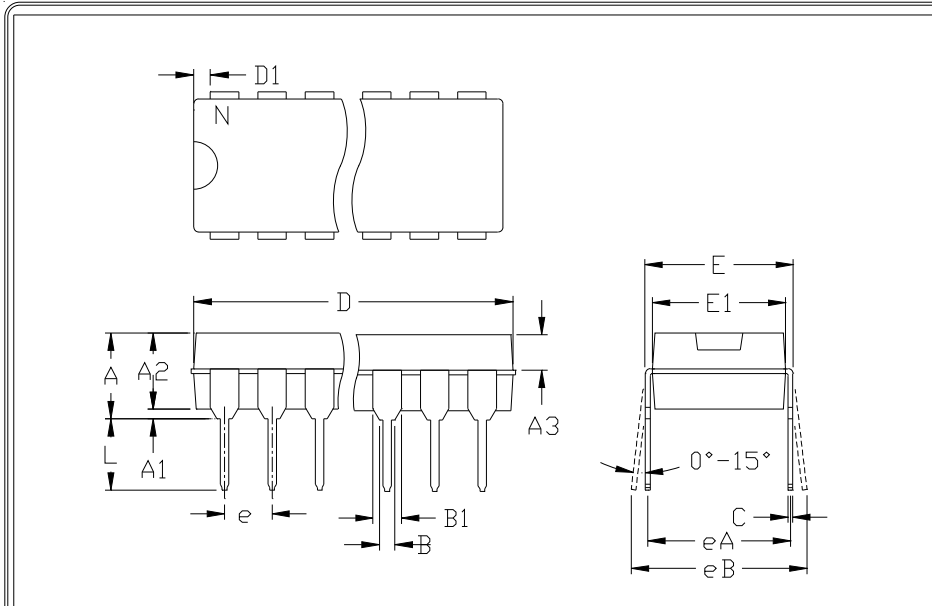

	INCHES		MILLIMETERS	
	MIN	MAX	MIN	MAX
A	---	0.200	---	5.08
A1	0.015	---	0.38	---
A2	0.125	0.175	3.18	4.45
A3	0.055	0.080	1.40	2.03
B	0.016	0.022	0.41	0.56
B1	0.045	0.065	1.14	1.65
C	0.008	0.012	0.20	0.30
D1	0.005	0.080	0.13	2.03
E	0.300	0.325	7.62	8.26
E1	0.240	0.310	6.10	7.87
e	0.100	---	2.54	---
eA	0.300	---	7.62	---
eB	---	0.400	---	10.16
L	0.115	0.150	2.92	3.81

	INCHES		MILLIMETERS		N	MS001
	MIN	MAX	MIN	MAX		
D	0.348	0.390	8.84	9.91	8	AB
D	0.735	0.765	18.67	19.43	14	AC
D	0.745	0.765	18.92	19.43	16	AA
D	0.885	0.915	22.48	23.24	18	AD
D	1.015	1.045	25.78	26.54	20	AE
D	1.14	1.265	28.96	32.13	24	AF
D	1.360	1.380	34.54	35.05	28	*5

- NOTES:
1. D&E DO NOT INCLUDE MOLD FLASH
 2. MOLD FLASH OR PROTRUSIONS NOT TO EXCEED .15mm (.006")
 3. CONTROLLING DIMENSION: MILLIMETER
 4. MEETS JEDEC MS001-XX AS SHOWN IN ABOVE TABLE
 5. SIMILAR TO JEDEC MO-058AB
 6. N = NUMBER OF PINS

PACKAGE FAMILY OUTLINE: PDIP .300" 1/1 21-0043 A
121 SAN GABRIEL DR. SUNNYVALE CA 94086 FAX (408) 737-7754 PROPRIETARY INFORMATION TITLE DOCUMENT CONTROL NUMBER REV

Maxim cannot assume responsibility for use of any circuitry other than circuitry entirely embodied in a Maxim product. No circuit patent licenses are implied. Maxim reserves the right to change the circuitry and specifications without notice at any time.

Maxim Integrated Products, 120 San Gabriel Drive, Sunnyvale, CA 94086 408-737-7600 _____ 13

Looking for pricing, stock, or lifecycle information?

Click below to explore more details on WIN SOURCE:

 [View MAX3093EEPE+ on WIN SOURCE](#)

 [Maxim Integrated](#) Information

Optimize Your Supply Chain with WIN SOURCE Solutions

-  Global Sourcing Solution
-  Obsolete Management
-  Cost Control Management
-  Shortage Management
-  Alternative Solution
-  Excess Inventory Management