



**THE DATASHEET OF
MAX378CWG+**





High-Voltage, Fault-Protected Analog Multiplexers

MAX378/MAX379

General Description

The MAX378 8-channel single-ended (1-of-8) multiplexer and the MAX379 4-channel differential (2-of-8) multiplexer use a series N-channel/P-channel/N-channel structure to provide significant fault protection. If the power supplies to the MAX378/MAX379 are inadvertently turned off while input voltages are still applied, *all* channels in the muxes are turned off, and only a few nanoamperes of leakage current will flow into the inputs. This protects not only the MAX378/MAX379 and the circuitry they drive, but also the sensors or signal sources that drive the muxes.

The series N-channel/P-channel/N-channel protection structure has two significant advantages over the simple current-limiting protection scheme of the industry's first-generation fault-protected muxes. First, the Maxim protection scheme limits fault currents to nanoamp leakage values rather than many milliamperes. This prevents damage to sensors or other sensitive signal sources. Second, the MAX378/MAX379 fault-protected muxes can withstand a *continuous* $\pm 60V$ input, unlike the first generation, which had a continuous $\pm 35V$ input limitation imposed by power dissipation considerations.

All digital inputs have logic thresholds of 0.8V and 2.4V, ensuring both TTL and CMOS compatibility without requiring pull-up resistors. Break-before-make operation is guaranteed. Power dissipation is less than 2mW.

Applications

Data Acquisition Systems
Industrial and Process Control Systems
Avionics Test Equipment
Signal Routing Between Systems

Features

- ◆ **Fault Input Voltage $\pm 75V$ with Power Supplies Off**
- ◆ **Fault Input Voltage $\pm 60V$ with $\pm 15V$ Power Supplies**
- ◆ **All Switches Off with Power Supplies Off**
- ◆ **On Channel Turns OFF if Overvoltage Occurs on Input or Output**
- ◆ **Only Nanoamperes of Input Current Under All Fault Conditions**
- ◆ **No Increase in Supply Currents Due to Fault Conditions**
- ◆ **Latchup-Proof Construction**
- ◆ **Operates from $\pm 4.5V$ to $\pm 18V$ Supplies**
- ◆ **All Digital Inputs are TTL and CMOS Compatible**
- ◆ **Low-Power Monolithic CMOS Design**

Ordering Information

PART	TEMP. RANGE	PIN-PACKAGE
MAX378CPE	0°C to +70°C	16 Plastic DIP
MAX378CWG	0°C to +70°C	24 Wide SO
MAX378CJE	0°C to +70°C	16 CERDIP
MAX378C/D	0°C to +70°C	Dice**
MAX378EPE	-40°C to +85°C	16 Plastic DIP
MAX378EWG	-40°C to +85°C	24 Wide SO
MAX378EJE	-40°C to +85°C	16 CERDIP
MAX378MJE	-55°C to +125°C	16 CERDIP
MAX378MLP	-55°C to +125°C	20 LCC*

Ordering Information continued at end of data sheet.

* Contact factory for availability.

**The substrate may be allowed to float or be tied to V+ (JI CMOS).

Pin Configurations

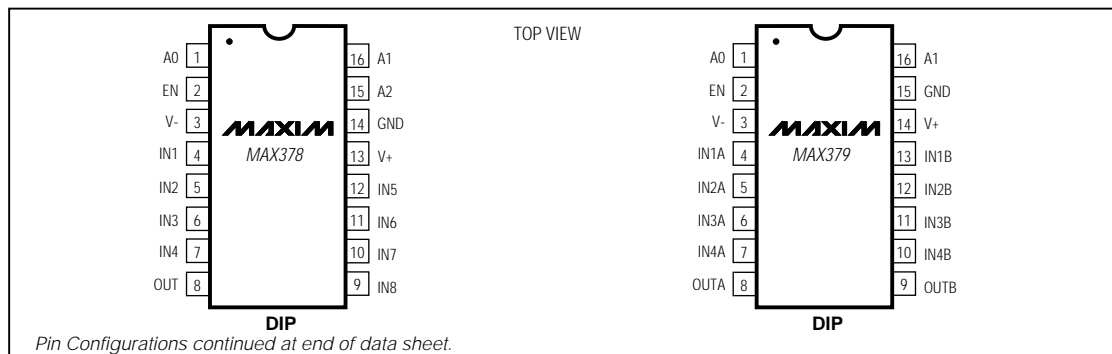

Maxim Integrated Products 1

Call toll free 1-800-998-8800 for free samples or literature.

High-Voltage, Fault-Protected Analog Multiplexers

ABSOLUTE MAXIMUM RATINGS

Voltage between Supply Pins	+4V	Continuous Current, IN or OUT	20mA
V+ to Ground	+22V	Peak Current, IN or OUT	
V- to Ground	-22V	(Pulsed at 1ms, 10% duty cycle max)	40mA
Digital Input Overvoltage:		Power Dissipation (Note 1) (CERDIP)	1.28W
V _{EN} , V _A { V+	+4V	Operating Temperature Range:	
{ V-	-4V	MAX378/379C	0°C to +70°C
Analog Input with Multiplexer Power On	±65V	MAX378/379E	-40°C to +85°C
{ Recommended } V+	+15V	MAX378/379M	-55°C to +125°C
{ Power Supplies } V-	-15V	Storage Temperature Range	-65°C to +150°C
Analog Input with Multiplexer Power Off	±80V	Note 1: Derate 12.8mW/°C above T _A = +75°C	

Stresses beyond those listed under "Absolute Maximum Ratings" may cause permanent damage to the device. These are stress ratings only, and functional operation of the device at these or any other conditions beyond those indicated in the operational sections of the specifications is not implied. Exposure to absolute maximum rating conditions for extended periods may affect device reliability.

ELECTRICAL CHARACTERISTICS

(V+ = +15V, V- = -15V; V_{AH} (Logic Level High) = +2.4V, V_{AL} (Logic Level Low) = +0.8V, unless otherwise noted.)

PARAMETER	SYMBOL	CONDITIONS	TEMP	-55°C to +125°C			0°C to +70°C and -40°C to +85°C			UNITS
				MIN	TYP	MAX	MIN	TYP	MAX	
STATIC										
ON Resistance	r _{DS(ON)}	V _{OUT} = ±10V, I _{IN} = 100μA V _{AL} = 0.8V, V _{AH} = 2.4V	+25°C	2.0	3.0		2.0	3.5		kΩ
			Full	3.0	4.0		3.0	4.0		
OFF Input Leakage Current	I _{IN(OFF)}	V _{IN} = ±10V, V _{OUT} = ∓10V V _{EN} = 0.8V (Note 6)	+25°C	-0.5	0.03	0.5	-1.0	0.03	1.0	nA
			Full	-50		50	-50		50	
OFF Output Leakage Current	I _{OUT(OFF)}	V _{OUT} = ±10V, V _{IN} = ∓10V V _{EN} = 0.8V MAX378 (Note 6) MAX379	+25°C	-1.0	0.1	1.0	-2.0	0.1	2.0	nA
			Full	-200		200	-200		200	
			Full	-100		100	-100		100	
ON Channel Leakage Current	I _{OUT(ON)}	V _{IN(ALL)} = V _{OUT} = ±10V V _{AH} = V _{EN} = 2.4V V _{AL} = 0.8V (Note 5) MAX378 MAX379	+25°C	-10	0.1	10	-20	0.1	20	nA
			Full	-600		600	-600		600	
			Full	-300		300	-300		300	
Analog Signal Range	V _{AN}	(Note 2)	Full	-15		+15	-15		+15	V
Differential OFF Output Leakage Current	I _{DIFF}	MAX379 only (Note 6)	Full	-50		50	-50		50	nA
FAULT										
Output Leakage Current (with Input Overvoltage)	I _{OUT(OFF)}	V _{OUT} = 0V, V _{IN} = ±60V (Notes 3, 4)	+25°C	20			20			nA
			Full	10			20			μA
Input Leakage Current (with Overvoltage)	I _{IN(OFF)}	V _{IN} = ±60V, V _{OUT} = ±10V (Notes 3, 4)	+25°C	25			40			μA
Input Leakage Current (with Power Supplies Off)	I _{IN(OFF)}	V _{IN} = ±75V, V _{EN} = V _{OUT} = 0V A ₀ = A ₁ = A ₂ = 0V or 5V	+25°C	10			20			μA
CONTROL										
Input Low Threshold	V _{AL}	(Note 4)	Full	0.8			0.8			V
Input High Threshold	V _{AH}	(Note 4)	Full	2.4			2.4			V
Input Leakage Current (High or Low)	I _A	V _A = 5V or 0V (Note 5)	Full	-1.0		1.0	-1.0		1.0	μA

High-Voltage, Fault-Protected Analog Multiplexers

MAX378/MAX379

ELECTRICAL CHARACTERISTICS (continued)

(V+ = +15V, V- = -15V; V_{AH} (Logic Level High) = +2.4V, V_{AL} (Logic Level Low) = +0.8V, unless otherwise noted.)

PARAMETER	SYMBOL	CONDITIONS	TEMP	-55°C to +125°C			0°C to +70°C and -40°C to +85°C			UNITS
				MIN	TYP	MAX	MIN	TYP	MAX	
DYNAMIC										
Access Time	t _A	Figure 1	+25°C	0.5	1.0		0.5	1.0		μs
Break-Before-Make Delay (Figure 2)	t _{ON-tOFF}	V _{EN} = +5V, V _{IN} = ±10V A ₀ , A ₁ , A ₂ strobed	+25°C	25	200		25	200		ns
Enable Delay (ON)	t _{ON(EN)}	Figure 3	+25°C	400	750		400	1000		ns
			Full		1000			1500		
Enable Delay (OFF)	t _{OFF(EN)}	Figure 3	+25°C	300	500		300			ns
			Full		1000			1000		
Settling Time (0.1%) (0.01%)	t _{SETT}		+25°C	1.2			1.2			μs
				3.5			3.5			
"OFF Isolation"	OFF(ISO)	V _{EN} = 0.8V, R _L = 1kΩ, C _L = 15pF V = 7V _{RMS} , f = 100kHz	+25°C	50	68		50	68		dB
Channel Input Capacitance	C _{IN(OFF)}		+25°C	5			5			pF
Channel Output Capacitance	C _{OUT(OFF)}	MAX378 MAX379	+25°C	25			25			pF
				12			12			
Digital Input Capacitance	C _A		+25°C	5			5			pF
Input to Output Capacitance	C _{D5(OFF)}		+25°C	0.1			0.1			pF
SUPPLY										
Positive Supply Current	I ₊	V _{EN} = 0.8V or 2.4V All V _A = 0V or 5V	+25°C	0.1	0.6		0.2	1.0		mA
			Full	0.3	0.7		0.5	1.0		
Negative Supply Current	I ₋	V _{EN} = 0.8V or 2.4V All V _A = 0V or 5V	+25°C	0.01	0.1		0.01	0.1		mA
			Full	0.02	0.2		0.02	0.1		
Power-Supply Range for Continuous Operation	V _{OP}	(Note 7)	+25°C	±4.5		±18	±4.5		±18	V

Note 2: When the analog signal exceeds +13.5V or -12V, the blocking action of Maxim's gate structure goes into operation. Only leakage currents flow and the channel ON resistance rises to infinity.

Note 3: The value shown is the steady-state value. The transient leakage is typically 50μA. See *Detailed Description*.

Note 4: Guaranteed by other static parameters.

Note 5: Digital input leakage is primarily due to the clamp diodes. Typical leakage is less than 1nA at +25°C.

Note 6: Leakage currents not tested at T_A = cold temp.

Note 7: Electrical characteristics, such as ON Resistance, will change when power supplies other than ±15V are used.

High-Voltage, Fault-Protected Analog Multiplexers

Typical Operating Characteristics

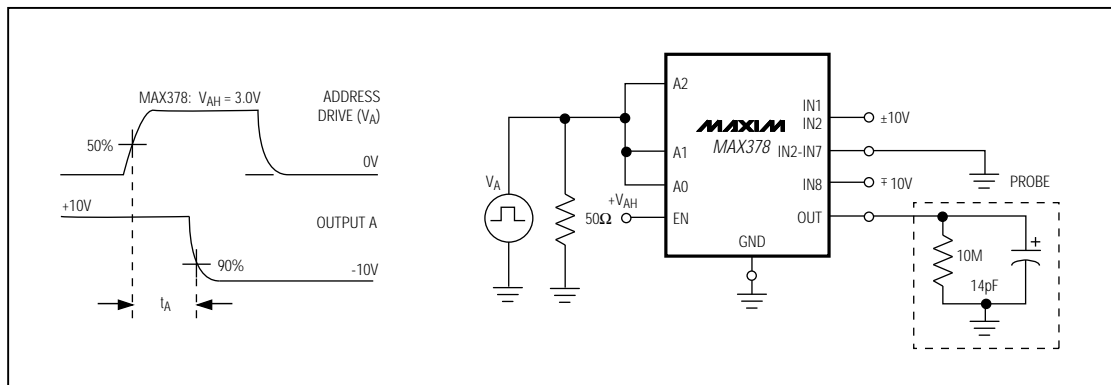
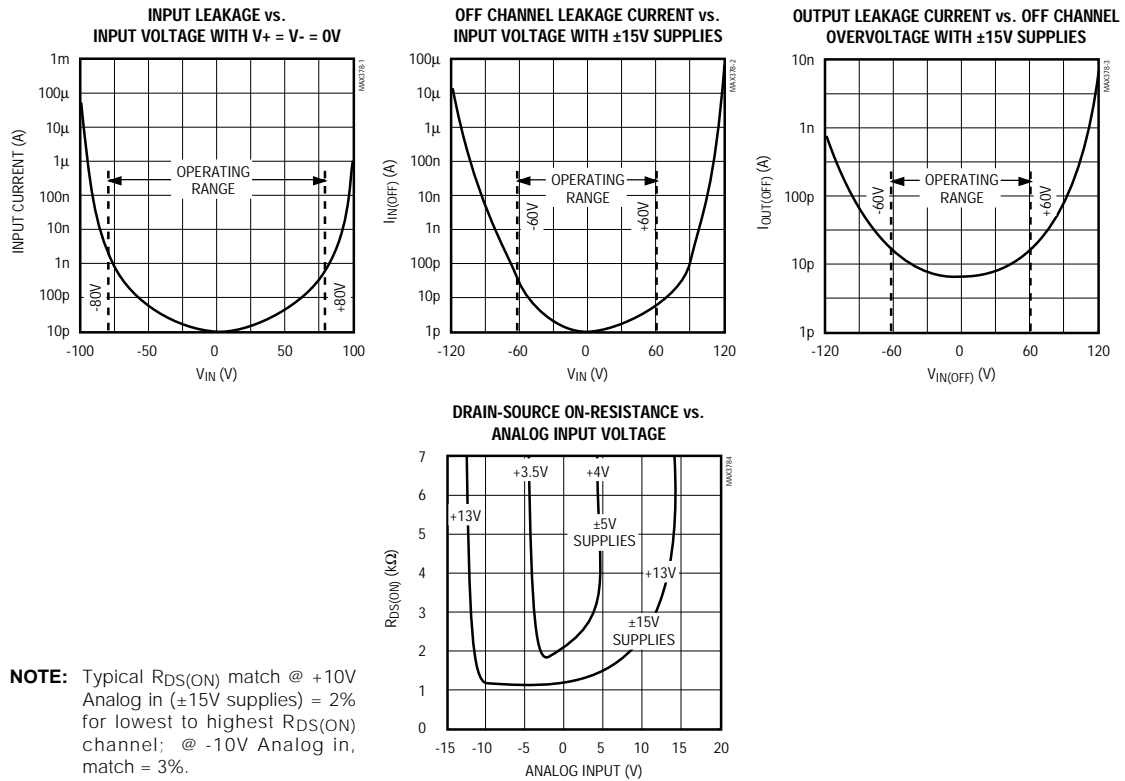

Figure 1. Access Time vs. Logic Level (High)

High-Voltage, Fault-Protected Analog Multiplexers

MAX378/MAX379

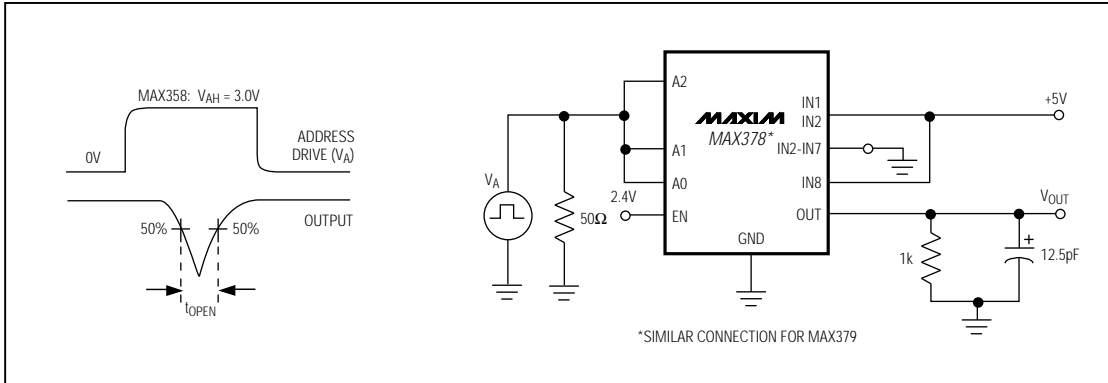

Figure 2. Break-Before-Make Delay (t_{OPEN})

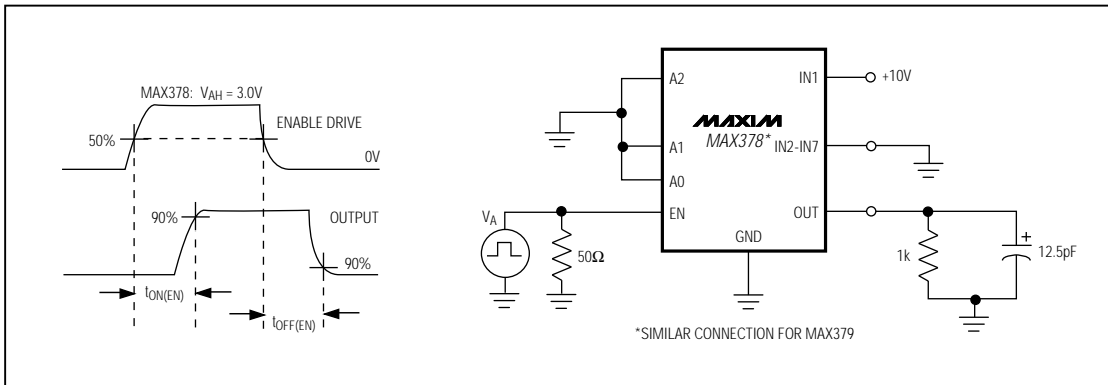

Figure 3. Enable Delay ($t_{ON(EN)}$, $t_{OFF(EN)}$)

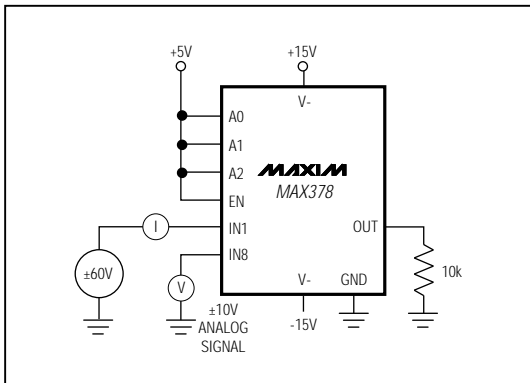

Figure 4. Input Leakage Current (Overvoltage)

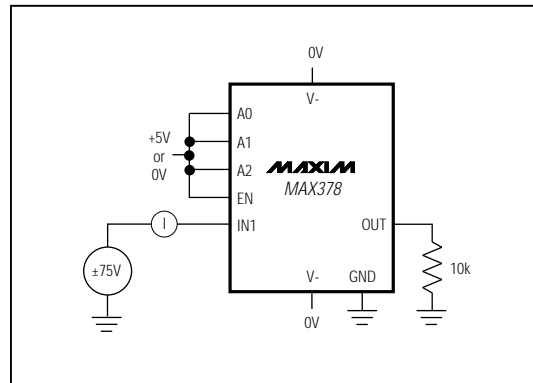

Figure 5. Input Leakage Current (with Power Supplies OFF)

High-Voltage, Fault-Protected Analog Multiplexers

Truth Table—MAX378

A2	A1	A0	EN	ON SWITCH
X	X	X	0	NONE
0	0	0	1	1
0	0	1	1	2
0	1	0	1	3
0	1	1	1	4
1	0	0	1	5
1	0	1	1	6
1	1	0	1	7
1	1	1	1	8

Truth Table—MAX379

A1	A0	EN	ON SWITCH
X	X	0	NONE
0	0	1	1
0	1	1	2
1	0	1	3
1	1	1	4

Note: Logic "0" = $V_{AL} \leq 0.8V$, Logic "1" = $V_{AH} \geq 2.4V$

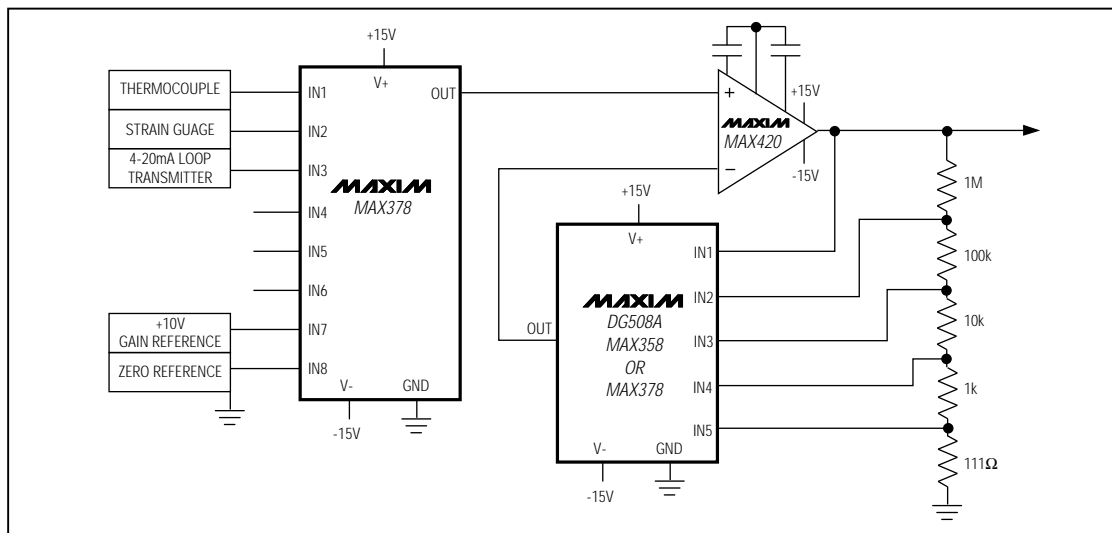

Figure 6. Typical Data Acquisition Front End

Typical Applications

Figure 6 shows a typical data acquisition system using the MAX378 multiplexer. Since the multiplexer is driving a high-impedance input, its error is a function of its own resistance ($R_{DS(ON)}$) times the multiplexer leakage current ($I_{OUT(ON)}$) and the amplifier bias current (I_{BIAS}):

$$\begin{aligned} V_{ERR} &= R_{DS(ON)} \times (I_{OUT(ON)} + I_{BIAS} \text{ (MAX420)}) \\ &= 2.0k\Omega \times (2nA + 30pA) \\ &= 18.0\mu V \text{ maximum error} \end{aligned}$$

In most cases, this error is low enough that preamplification of input signals is not needed, even with very low-level signals such as $40\mu V/^\circ C$ from type J thermocouples.

In systems with fewer than eight inputs, an unused channel can be connected to the system ground reference point for software zero correction. A second channel connected to the system voltage reference allows gain correction of the entire data acquisition system as well.

A MAX420 precision op amp is connected as a programmable-gain amplifier, with gains ranging from 1 to 10,000. The guaranteed $5\mu V$ unadjusted offset of the MAX420 maintains high signal accuracy, while programmable gain allows the output signal level to be scaled to the optimum range for the remainder of the data acquisition system, normally a Sample/Hold and A/D. Since the gain-changing multiplexer is not connected to the external sensors, it can be either a DG508A multiplexer or the fault-protected MAX358 or MAX378.

High-Voltage, Fault-Protected Analog Multiplexers

MAX378/MAX379

Input switching, however, must be done with a fault-protected MAX378 multiplexer, to provide the level of protection and isolation required with most data acquisition inputs. Since external signal sources may continue to supply voltage when the multiplexer and system power are turned off, non-fault-protected multiplexers, or even first-generation fault-protected devices, will allow many milliamps of fault current to flow from outside sources into the multiplexer. This could result in damage to either the sensors or the multiplexer. A non-fault-protected multiplexer will also allow input overvoltages to appear at its output, perhaps damaging Sample/Holds or A/Ds. Such input overdrives may also cause input-to-input shorts, allowing the high current output of one sensor to possibly damage another.

The MAX378 eliminates all of the above problems. It not only limits its output voltage to safe levels, with or without power applied ($V+$ and $V-$), but also turns all channels off when power is removed. This allows it to draw only sub-microamp fault currents from the inputs, and maintain isolation between inputs for continuous input levels up to $\pm 75V$ with power supplies off.

Detailed Description

Fault Protection Circuitry

The MAX378/MAX379 are fully fault protected for continuous input voltages up to $\pm 60V$, whether or not the $V+$ and $V-$ power supplies are present. These devices use a "series FET" switching scheme which not only protects the multiplexer output from overvoltage, but also limits the input current to sub-microamp levels.

Figures 7 and 8 show how the series FET circuit protects against overvoltage conditions. When power is off, the gates of all three FETs are at ground. With a $-60V$ input, N-channel FET Q1 is turned on by the $+60V$ gate-

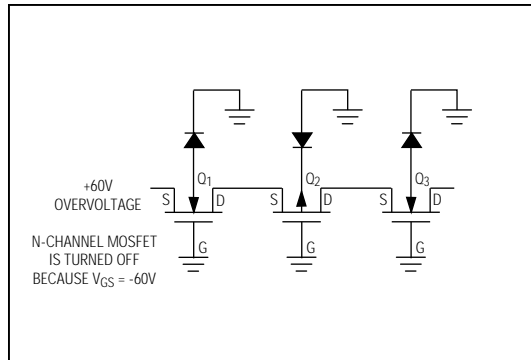

Figure 8. +60V Overvoltage with Multiplexer Power OFF

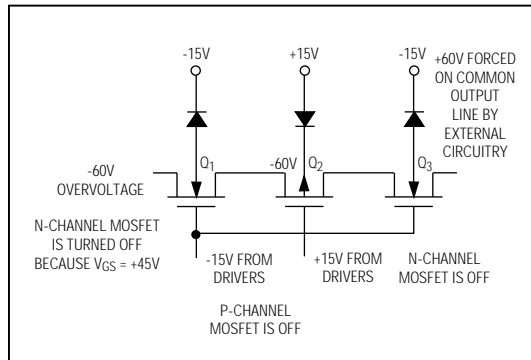

Figure 9. -60V Overvoltage on an OFF Channel with Multiplexer Power Supply ON

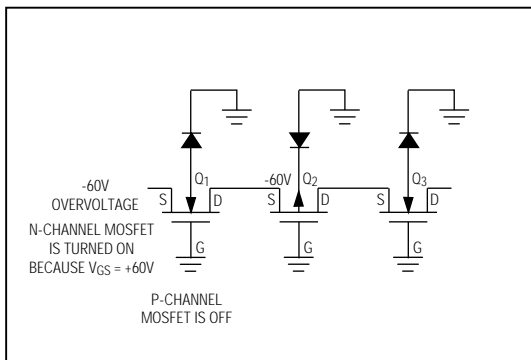

Figure 7. -60V Overvoltage with Multiplexer Power OFF

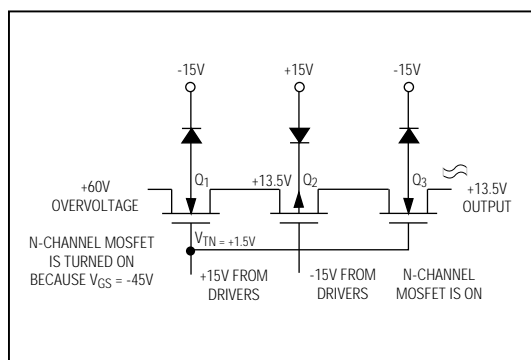

Figure 10. +60V Overvoltage Input to the ON Channel

High-Voltage, Fault-Protected Analog Multiplexers

to-source voltage. The P-channel device (Q2), however, has +60V V_{GS} and is turned off, thereby preventing the input signal from reaching the output. If the input voltage is +60V, Q1 has a negative V_{GS} , which turns it off. Similarly, only sub-microamp leakage currents can flow from the output back to the input, since any voltage will turn off either Q1 or Q2.

Figure 9 shows the condition of an OFF channel with V_+ and V_- present. As with Figures 7 and 8, either an N-channel or a P-channel device will be off for any input voltage from -60V to +60V. The leakage current with negative overvoltages will immediately drop to a few nanoamps at +25°C. For positive overvoltages, that fault current will initially be 40 μ A or 50 μ A, decaying over a few seconds to the nanoamp level. The time constant of this decay is caused by the discharge of stored charge from internal nodes, and does not compromise the fault-protection scheme.

Figure 10 shows the condition of the ON channel with V_+ and V_- present. With input voltages less than $\pm 10V$, all three FETs are on and the input signal appears at the output. If the input voltage exceeds V_+ minus the N-channel threshold voltage (V_{TN}), then the N-channel FET will turn off. For voltages more negative than V_- minus the P-channel threshold (V_{TP}), the P-channel device will turn off. Since V_{TN} is typically 1.5V and V_{TP} is typically 3V, the multiplexer's output swing is limited to about -12V to +13.5V with $\pm 15V$ supplies.

The *Typical Operating Characteristics* graphs show typical leakage vs. input voltage curves. Although the maximum rated input of these devices is $\pm 65V$, the MAX378/MAX379 typically have excellent performance up to $\pm 75V$, providing additional margin for the unknown transients that exist in the real world. In summary, the MAX378/MAX379 provide superior protection from all fault conditions while using a standard, readily produced junction-isolated CMOS process.

Switching Characteristics and Charge Injection

Table 1 shows typical charge-injection levels vs. power-supply voltages and analog input voltage. Note that since the channels are well matched, the differential charge injection for the MAX379 is typically less than 5pC. The charge injection that occurs during switching creates a voltage transient whose magnitude is inversely proportional to the capacitance on the multiplexer output.

The channel-to-channel switching time is typically 600ns, with about 200ns of break-before-make delay. This 200ns break-before-make delay prevents the input-to-input short that would occur if two input channels were simultaneous-

ly connected to the output. In a typical data acquisition system, such as in Figure 6, the dominant delay is not the switching time of the MAX378 multiplexer, but is the settling time of the following amplifiers and S/H. Another limiting factor is the RC time constant of the multiplexer $R_{DS(ON)}$ plus the signal source impedance multiplied by the load capacitance on the output of the multiplexer. Even with low signal source impedances, 100pF of capacitance on the multiplexer output will approximately double the settling time to 0.01% accuracy.

Operation with Supply Voltage Other than $\pm 15V$

The main effect of supply voltages other than $\pm 15V$ is the reduction in output signal range. The MAX378 limits the output voltage to about 1.5V below V_+ and about 3V above V_- . In other words, the output swing is limited to +3.5V to -2V when operating from $\pm 5V$. The *Typical Operating Characteristics* graphs show typical $R_{DS(ON)}$, for $\pm 15V$, $\pm 10V$, and $\pm 5V$ power supplies. Maxim tests and guarantees the MAX378/MAX379 for operation from $\pm 4.5V$ to $\pm 18V$ supplies. The switching delays are increased by about a factor of 2 at $\pm 5V$, but break-before-make action is preserved.

The MAX378/MAX379 can be operated with a single +9V to +22V supply, as well as asymmetrical power supplies such as +15V and -5V. The digital threshold will remain approximately 1.6V above GND and the analog characteristics such as $R_{DS(ON)}$ are determined by the total voltage difference between V_+ and V_- . Connect V_- to 0V when operating with a +9V to +22V single supply.

This means that the MAX378/MAX379 will operate with standard TTL-logic levels, even with $\pm 5V$ power supplies. In all cases, the threshold of the EN pin is the same as the other logic inputs.

Table 1a. MAX378 Charge Injection

Supply Voltage	Analog Input Level	Injected Charge
$\pm 5V$	+1.7V	+100pC
	0V	+70pC
	-1.7V	+45pC
$\pm 10V$	+5V	+200pC
	0V	+130pC
	-5V	+60pC
$\pm 15V$	+10V	+500pC
	0V	+180pC
	-10V	+50pC

Test Conditions: $C_L = 1000pF$ on multiplexer output; the tabulated analog input level is applied to channel 1; channels 2 through 8 are open circuited. EN = +5V, A1 = A2 = 0V, A0 is toggled at 2kHz rate between 0V and 3V. +100pC of charge creates a +100mV step when injected into a 1000pF load capacitance.

High-Voltage, Fault-Protected Analog Multiplexers

MAX378/MAX379

Table 1b. MAX379 Charge Injection

Supply Voltage	Analog Input Level	Injected Charge		
		Out A	Out B	Differential A-B
±5V	+1.7V	+105pC	+107pC	-2pC
	0V	+73pC	+74pC	-1pC
	-1.7V	+48pC	+50pC	-2pC
±10V	+5V	+215pC	+220pC	-5pC
	0V	+135pC	+139pC	-4pC
	-5V	+62pC	+63pC	-1pC
±15V	+10V	+525pC	+530pC	-5pC
	0V	+180pC	+185pC	-5pC
	-10V	+55pC	+55pC	0pC

Test Conditions: $C_L = 1000\text{pF}$ on Out A and Out B; the tabulated analog input level is applied to inputs 1A and 1B; channels 2 through 4 are open circuited. $EN = +5V$, $A1 = 0V$, $A0$ is toggled from 0V to 3V at a 2kHz rate.

Digital Interface Levels

The typical digital threshold of both the address lines and the EN pin is 1.6V, with a temperature coefficient of about $-3\text{mV}/^\circ\text{C}$. This ensures compatibility with 0.8V to 2.4V TTL-logic swings over the entire temperature range. The digital threshold is relatively independent of the supply voltages, moving from 1.6V typical to 1.5V typical as the power supplies are reduced from $\pm 15V$ to $\pm 5V$. In all cases, the digital threshold is referenced to GND.

The digital inputs can also be driven with CMOS-logic levels swinging from either $V+$ to $V-$ or from $V+$ to GND. The digital input current is just a few nanoamps of leakage at all input voltage levels, with a guaranteed maximum of $1\mu\text{A}$. The digital inputs are protected from ESD by a 30V zener diode between the input and $V+$, and can be driven $\pm 4V$ beyond the supplies without drawing excessive current.

Operation as a Demultiplexer

The MAX378/MAX379 will function as a demultiplexer, where the input is applied to the OUT pin, and the input pins are used as outputs. The MAX378/MAX379 provide both break-before-make action and full fault protection when operated as a demultiplexer, unlike earlier generations of fault-protected multiplexers.

Channel-to-Channel Crosstalk, Off Isolation, and Digital Feedthrough

At DC and low frequencies, channel-to-channel crosstalk is caused by variations in output leakage cur-

rents as the off-channel input voltages are varied. The MAX378 output leakage varies only a few picoamps as all seven off inputs are toggled from $-10V$ to $+10V$. The output voltage change depends on the impedance level at the MAX378 output, which is $R_{DS(ON)}$ plus the input signal source resistance in most cases, since the load driven by the MAX378 is usually a high impedance. For a signal source impedance of $10\text{k}\Omega$ or lower, the DC crosstalk exceeds 120dB.

Table 2 shows typical AC crosstalk and off-isolation performance. Digital feedthrough is masked by the analog charge injection when the output is enabled. When the output is disabled, the digital feedthrough is virtually unmeasurable, since the digital pins are physically isolated from the analog section by the GND and $V-$ pins. The ground plane formed by these lines is continued onto the MAX378/MAX379 die to provide over 100dB isolation between the digital and analog sections.

Table 2a. Typical Off-Isolation Rejection Ratio

Frequency	100kHz	500kHz	1MHz
One Channel Driven	74dB	72dB	66dB
All Channels Driven	64dB	48dB	44dB

Test Conditions: $V_{IN} = 20V_{P-P}$ at the tabulated frequency, $R_L = 1.5\text{k}\Omega$ between OUT and GND, $EN = 0V$.

$$\text{OIRR} = 20 \text{ Log } \frac{20V_{P-P}}{V_{OUT(P-P)}}$$

Table 2b. Typical Crosstalk Rejection Ratio

Frequency	100kHz	500kHz	1MHz
$F_L = 1.5\text{k}$	70dB	68dB	64dB
$R_L = 10\text{k}$	62dB	46dB	42dB

Test Conditions: Specified R_L connected from OUT to GND, $EN = +5V$, $A0 = A1 = A2 = +5V$ (Channel 1 selected). $20V_{P-P}$ at the tabulated frequency is applied to Channel 2. All other channels are open circuited. Similar crosstalk rejection can be observed between any two channels.

High-Voltage, Fault-Protected Analog Multiplexers

Pin Configurations (continued)

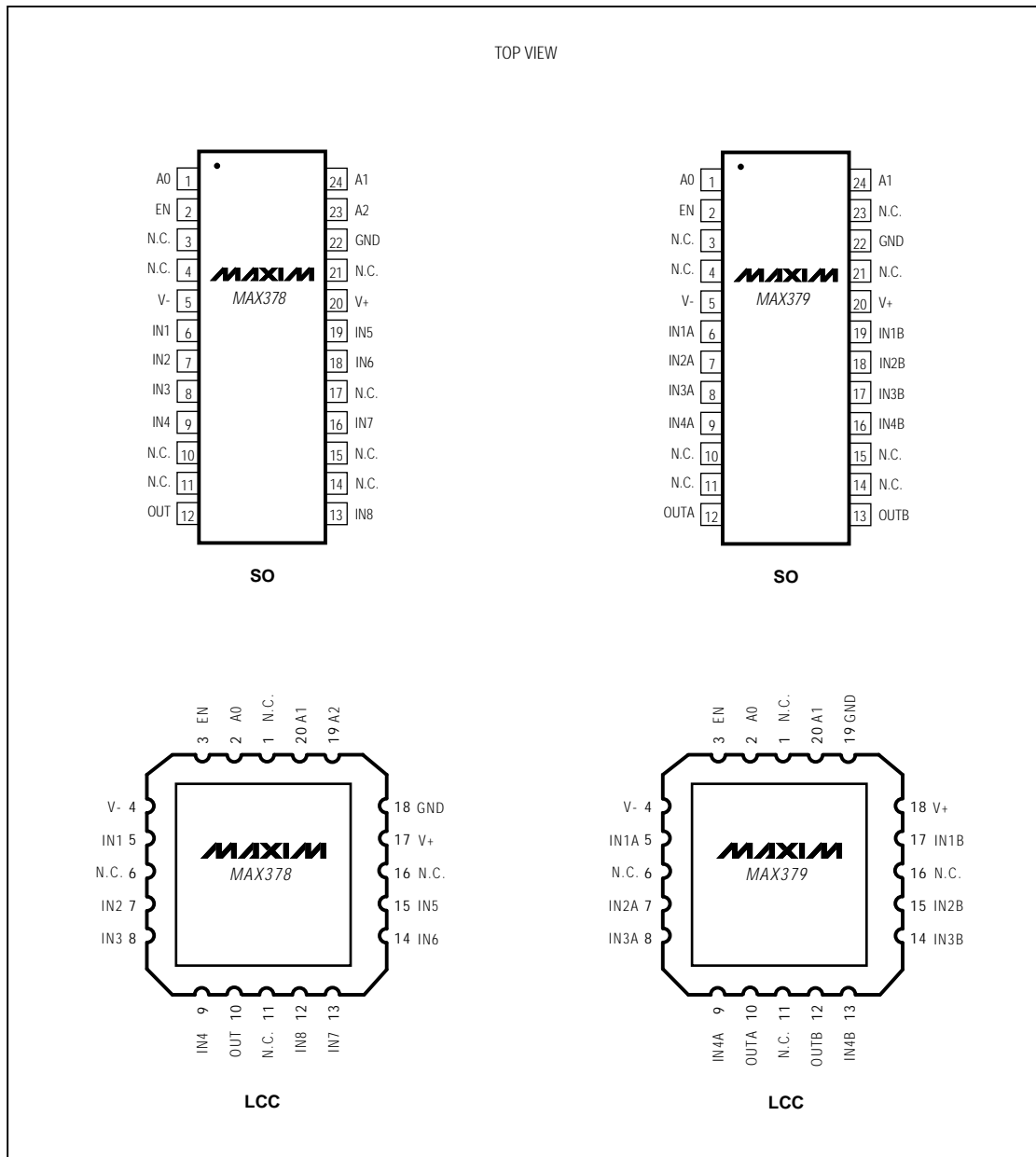

High-Voltage, Fault-Protected Analog Multiplexers

_Ordering Information (continued)

PART	TEMP. RANGE	PIN-PACKAGE
MAX379CPE	0°C to +70°C	16 Plastic DIP
MAX379CWG	0°C to +70°C	24 Wide SO
MAX379CJE	0°C to +70°C	16 CERDIP
MAX379C/D	0°C to +70°C	Dice**
MAX379EPE	-40°C to +85°C	16 Plastic DIP
MAX379EWG	-40°C to +85°C	24 Wide SO
MAX379EJE	-40°C to +85°C	16 CERDIP
MAX379MJE	-55°C to +125°C	16 CERDIP
MAX379MLP	-55°C to +125°C	20 LCC*

* Contact factory for availability.

**The substrate may be allowed to float or be tied to V+ (JI CMOS).

Chip Topographies

MAX378/MAX379

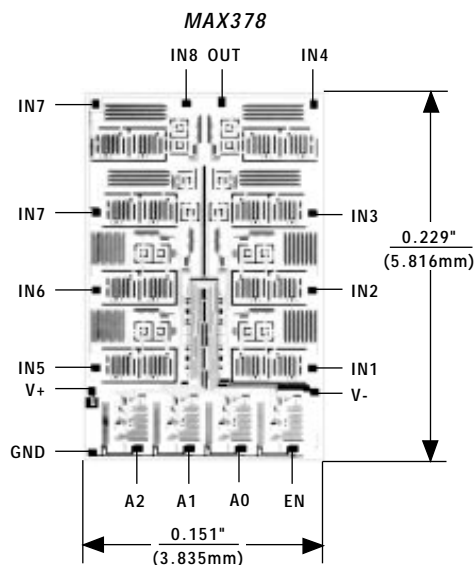

NOTE: Connect substrate to V+ or leave it floating.

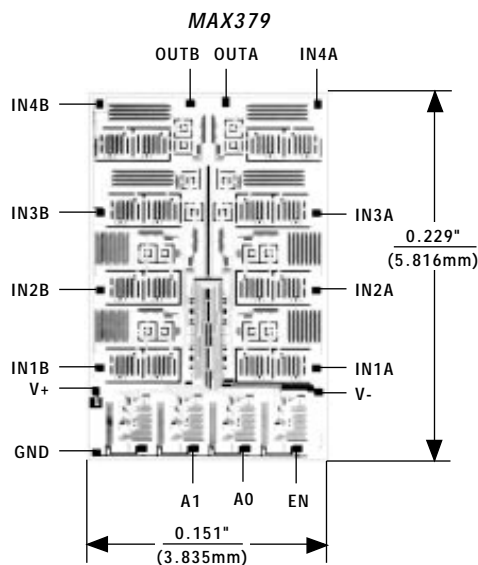

NOTE: Connect substrate to V+ or leave it floating.

High-Voltage, Fault-Protected Analog Multiplexers

Package Information

**Wide SO
SMALL-OUTLINE
PACKAGE
(0.300 in.)**

DIM	INCHES		MILLIMETERS	
	MIN	MAX	MIN	MAX
A	0.093	0.104	2.35	2.65
A1	0.004	0.012	0.10	0.30
B	0.014	0.019	0.35	0.49
C	0.009	0.013	0.23	0.32
E	0.291	0.299	7.40	7.60
e	0.050		1.27	
H	0.394	0.419	10.00	10.65
L	0.016	0.050	0.40	1.27

DIM	PINS	INCHES		MILLIMETERS	
		MIN	MAX	MIN	MAX
D	16	0.398	0.413	10.10	10.50
D	18	0.447	0.463	11.35	11.75
D	20	0.496	0.512	12.60	13.00
D	24	0.598	0.614	15.20	15.60
D	28	0.697	0.713	17.70	18.10

21-0042A

**16-PIN PLASTIC
DUAL-IN-LINE
PACKAGE**

DIM	INCHES		MILLIMETERS	
	MIN	MAX	MIN	MAX
A	-	0.200	-	5.08
A1	0.015	-	0.38	-
A2	0.125	0.150	3.18	3.81
A3	0.055	0.080	1.40	2.03
B	0.016	0.022	0.41	0.56
B1	0.050	0.065	1.27	1.65
C	0.008	0.012	0.20	0.30
D	0.745	0.765	18.92	19.43
D1	0.005	0.030	0.13	0.76
E	0.300	0.325	7.62	8.26
E1	0.240	0.280	6.10	7.11
e	0.100 BSC		2.54 BSC	
e _A	0.300 BSC		7.62 BSC	
e _B	-	0.400	-	10.16
L	0.115	0.150	2.92	3.81
α	0°	15°	0°	15°

21-587A

Maxim cannot assume responsibility for use of any circuitry other than circuitry entirely embodied in a Maxim product. No circuit patent licenses are implied. Maxim reserves the right to change the circuitry and specifications without notice at any time.

12 Maxim Integrated Products, 120 San Gabriel Drive, Sunnyvale, CA 94086 (408) 737-7600

Looking for pricing, stock, or lifecycle information?

Click below to explore more details on WIN SOURCE:

 [View MAX378CWG+](#) on WIN SOURCE

 [Maxim Integrated](#) Information

Optimize Your Supply Chain with WIN SOURCE Solutions

-  Global Sourcing Solution
-  Obsolete Management
-  Cost Control Management
-  Shortage Management
-  Alternative Solution
-  Excess Inventory Management