

Low-Cost, Remote Temperature Switch

General Description

The MAX6513 is a fully integrated, remote temperature switch that uses an external P-N junction (typically a diode-connected transistor) as the sensing element to measure the remote temperature. The device asserts a logic signal when the temperature crosses a factory-programmed threshold. Available trip thresholds are from +45°C to +125°C in 10°C increments. Accuracy is within $\pm 3^\circ\text{C}$ ($T_A = -5^\circ\text{C}$ to $+55^\circ\text{C}$) or $\pm 5^\circ\text{C}$ ($T_A = -40^\circ\text{C}$ to $+85^\circ\text{C}$). Hysteresis is pin selectable to 5°C or 10°C.

The MAX6513 has an active-high CMOS output. The output is asserted when the temperature exceeds the threshold value. The active-high CMOS output can directly drive a power FET to control a cooling fan.

The MAX6513 operates from a +3.0V to +5.5V supply and typically consumes 400 μA of supply current. It is available in a 6-pin lead-free TDFN package.

Applications

CPU Temperature Monitoring in High-Speed Computers
 Multichip Modules
 Battery Packs
 Temperature Control
 Temperature Alarms
 Fan Control

Features

- ◆ Continuously Measure External Junction Temperature
- ◆ Factory-Programmed Temperature Threshold from +45°C to +125°C in 10°C Increments
- ◆ Insensitive to Series Parasitic Resistance
- ◆ Active-High Output for Direct Fan Control
- ◆ < 100ms Response Time
- ◆ Accuracy
 - $\pm 3^\circ\text{C}$ ($T_{\text{REMOTE}} = +45^\circ\text{C}$ to $+125^\circ\text{C}$, $T_A = -5^\circ\text{C}$ to $+55^\circ\text{C}$)
 - $\pm 5^\circ\text{C}$ ($T_{\text{REMOTE}} = +45^\circ\text{C}$ to $+125^\circ\text{C}$, $T_A = -40^\circ\text{C}$ to $+85^\circ\text{C}$)
- ◆ Pin-Selectable 5°C or 10°C Hysteresis
- ◆ 400 μA Average Current Consumption
- ◆ +3.0V to +5.5V Supply Range
- ◆ 6-Pin TDFN Package (Lead(Pb)-Free) with Exposed Pad

Ordering Information

PART	TEMP RANGE	PIN-PACKAGE
MAX6513TT_ _ _ +T	-40°C to +85°C	6 TDFN-EP*

Note: These parts are offered in nine standard temperature versions with a minimum order of 2500 pieces. To complete the suffix information, select an available trip point in degrees centigrade from the device marking codes table. For example, the MAX6513TT065+T describes a MAX6513 in a 6-pin TDFN package with a +65°C threshold.

+Denotes a lead(Pb)-free/RoHS-compliant package.

T = Tape and reel.

*EP = Exposed pad.

Typical Operating Circuit

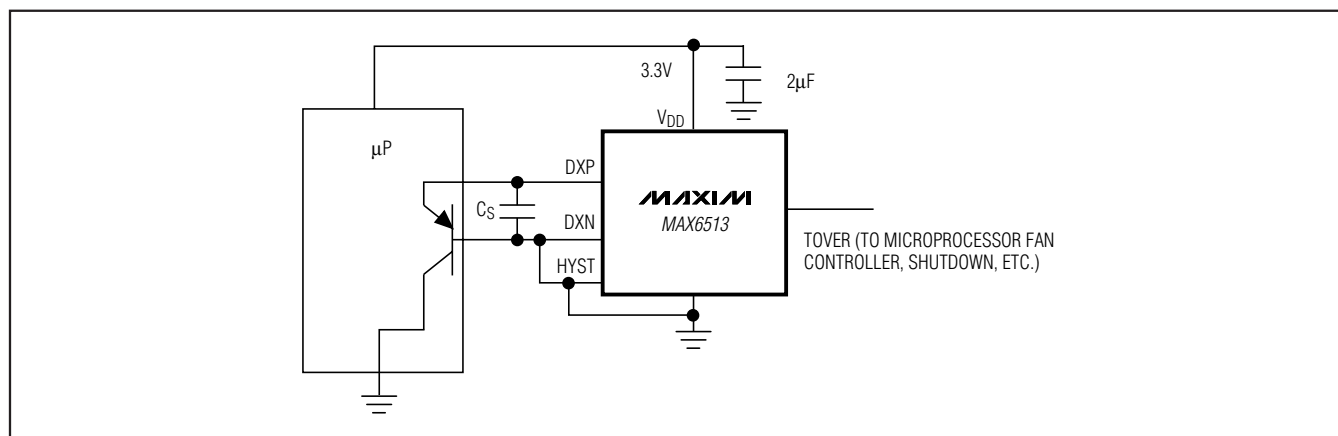

Low-Cost, Remote Temperature Switch

ABSOLUTE MAXIMUM RATINGS

Supply Voltage (V_{DD})-0.3V to +6V
 DXP, DXN, HYST, TOVER.....-0.3V to ($V_{DD} + 0.3$ V)
 TOVER Output Current.....-1mA/+50mA
 DXN Input Current.....-1mA/+50mA
 Current (all other pins)..... ± 20 mA
 Continuous Power Dissipation ($T_A = +70^\circ\text{C}$)
 TDFN (derate 18.2mW/ $^\circ\text{C}$ above $+70^\circ\text{C}$).....1455mW

Operating Temperature Range-40 $^\circ\text{C}$ to +85 $^\circ\text{C}$
 Storage Temperature Range-65 $^\circ\text{C}$ to +150 $^\circ\text{C}$
 Junction Temperature+150 $^\circ\text{C}$
 Lead Temperature (soldering, 10s)+300 $^\circ\text{C}$
 Soldering Temperature+260 $^\circ\text{C}$

Stresses beyond those listed under "Absolute Maximum Ratings" may cause permanent damage to the device. These are stress ratings only, and functional operation of the device at these or any other conditions beyond those indicated in the operational sections of the specifications is not implied. Exposure to absolute maximum rating conditions for extended periods may affect device reliability.

ELECTRICAL CHARACTERISTICS

($V_{DD} = +3.0\text{V}$ to $+5.5\text{V}$, $C_S = 2200\text{pF}$, $T_A = -40^\circ\text{C}$ to $+85^\circ\text{C}$, $T_{\text{REMOTE}} = +45^\circ\text{C}$ to $+125^\circ\text{C}$ (Note 1), unless otherwise noted. Typical values are at $T_A = +25^\circ\text{C}$.) (Note 2)

PARAMETER	SYMBOL	CONDITIONS	MIN	TYP	MAX	UNITS
Supply Voltage Range	V_{DD}		3.0		5.5	V
Supply Current	I_{DD}			400	600	μA
Temperature Threshold Accuracy (Note 3)	ΔT_{TH}	$T_A = -5^\circ\text{C}$ to $+55^\circ\text{C}$	-3.0		+3.0	$^\circ\text{C}$
		$T_A = -40^\circ\text{C}$ to $+85^\circ\text{C}$	-5.0		+5.0	
Power-Supply Sensitivity for Temperature Trip Point				-0.6		$^\circ\text{C}/\text{V}$
Temperature Threshold Hysteresis	T_{HYST}	$\text{HYST} = V_{\text{IL}}$		5		$^\circ\text{C}$
		$\text{HYST} = V_{\text{IH}}$		10		
Response Time				70	120	ms
Input Voltage High	V_{IH}		$V_{DD} - 0.2$			V
Input Voltage Low	V_{IL}				0.2	V
Output Voltage High	V_{OH}	$I_{\text{OUT}} = 1\text{mA}$	$V_{DD} - 0.2$			V
Output Voltage Low	V_{OL}	$I_{\text{OUT}} = 1\text{mA}$			0.2	V
Maximum DXP Source Current		$0.4\text{V} \leq V_{\text{DXP}} \leq 2\text{V}$, $\text{DXN} = \text{GND}$		270		μA
Minimum DXP Source Current		$0.4\text{V} \leq V_{\text{DXP}} \leq 2\text{V}$, $\text{DXN} = \text{GND}$		9		μA

Note 1: T_{REMOTE} refers to the temperature of the remote-sensing junction. T_A refers to the temperature of the MAX6513 package.

Note 2: All parameters are 100% production tested at $T_A = +25^\circ\text{C}$. Specifications over temperature limits are guaranteed by design.

Note 3: This parameter is guaranteed by design to ± 3.5 sigma.

Low-Cost, Remote Temperature Switch

Typical Operating Characteristics

($V_{DD} = +3.3V$, $C_S = 2200pF$, $T_A = +25^\circ C$, unless otherwise noted.)

MAX6513

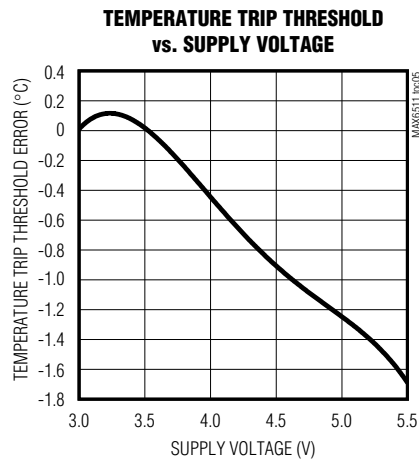
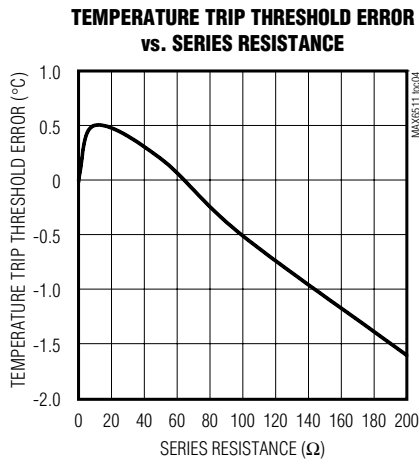
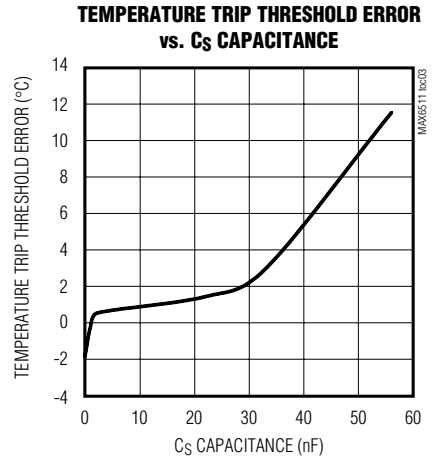
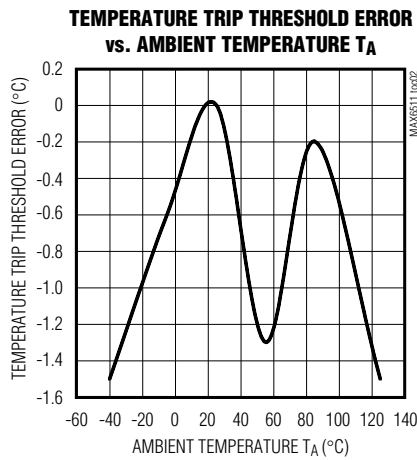
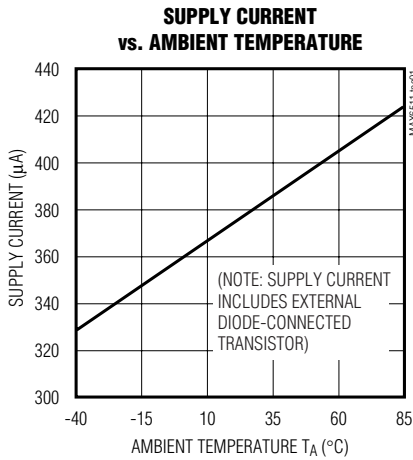

Low-Cost, Remote Temperature Switch

Pin Configuration

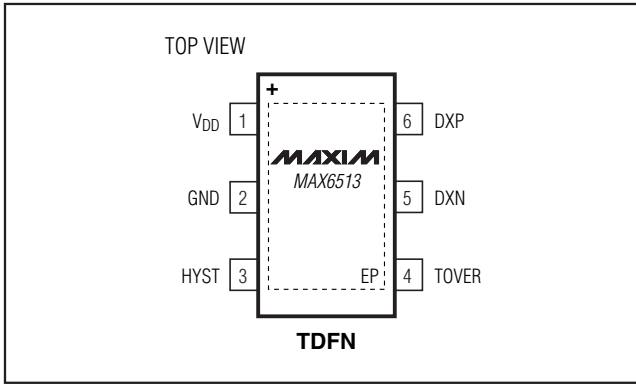

Pin Description

PIN	NAME	FUNCTION
1	V _{DD}	Power-Supply Input, +3.0V to +5.5V. Bypass V _{DD} to GND with a 0.1µF capacitor.
2	GND	Ground
3	HYST	Hysteresis Selection. Hysteresis is 10°C for HYST = V _{DD} , 5°C for HYST = GND.
4	TOVER	CMOS Active-High Output. TOVER goes high when the temperature exceeds the factory-programmed temperature threshold.
5	DXN	This pin connects to the negative (cathode) terminal of the external P-N sense junction. DXN must be connected to GND.
6	DXP	This pin connects to the positive (anode) terminal of the external P-N sense junction.
—	EP	Exposed Pad. Not internally connected. Connect to GND or leave unconnected.

Detailed Description

The MAX6513 fully integrated temperature switch incorporates a precision bandgap reference, a conversion block, a current source, and a comparator (Figure 1). The device uses an external P-N junction as the temperature-sensing element. It steers bias currents through the external diode, measures the forward voltages, and computes the temperature using a precision chopper stabilized amplifier.

Resistance values of less than 100Ω in series with the external sense junction will result in trip-point errors < 1°C. The MAX6513 provides noise immunity by integration and oversampling of the diode voltage, but good design practice includes routing the DXP and DXN lines away from noise sources, such as high-speed digital lines, switching regulators, inductors, and transformers. The DXP and DXN traces should be paired together and surrounded by ground plane whenever possible.

In applications where the temperature changes rapidly, the measured temperature will be approximately equal to the average value of the temperature during the measurement period.

The MAX6513 has an active-high CMOS output, and is available with preset temperature thresholds from +45°C to +125°C in 10°C increments.

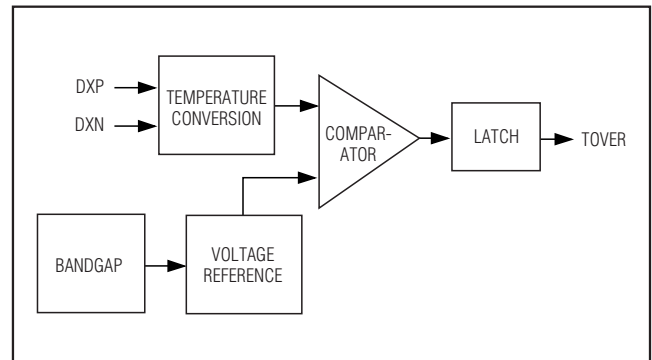

Figure 1. Functional Block Diagram

Low-Cost, Remote Temperature Switch

MAX6513

Table 1. Sensor Transistor Manufacturers

MANUFACTURER	MODEL NUMBER
Central Semiconductor (USA)	CMPT3904
ON (USA)	MMBT3904
Rohm Semiconductor (Japan)	SST3904
Samsung (Korea)	KST3904-TF
Siemens (Germany)	SMBT3904
Zetex (England)	FMMT3904CT-ND

Note: Transistors must be diode connected (base shorted to collector).

Hysteresis Input

The HYST pin is a CMOS-compatible input that selects hysteresis at either a high level (10°C for HYST = V_{DD}) or a low level (5°C for HYST = GND). Hysteresis prevents the output from chattering when the temperature is near the trip point. The HYST pin must not be left unconnected.

The output asserts when the temperature exceeds the trip point and deasserts when the temperature falls back below the trip point minus the hysteresis. For example, if the trip point is 105°C, the output will assert at 105°C and will not deassert until temperature falls below 105°C minus the hysteresis (e.g., 95°C if 10°C hysteresis is chosen) (Figure 2).

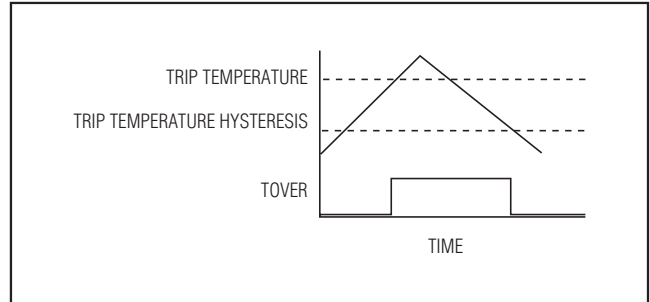

Figure 2. Temperature Trip Threshold Hysteresis

Device Marking Codes for TDFN Package

DEVICE	CODE	TEMPERATURE TRIP THRESHOLD (°C)
MAX6513TT045	+ACU	45
MAX6513TT055	+ACV	55
MAX6513TT065	+ACW	65
MAX6513TT075	+ACX	75
MAX6513TT085	+ACY	85
MAX6513TT095	+ACZ	95
MAX6513TT105	+ADA	105
MAX6513TT115	+ADB	115
MAX6513TT125	+ADC	125

Applications Information

Remote-Diode Selection

To ensure best accuracy, use a good-quality diode-connected transistor. Suggested devices are listed in Table 1. Large power transistors are not recommended. Tight specifications for forward current gain indicate the manufacturer has good process controls and that the devices have consistent V_{be} characteristics. The MAX6513 can also measure the die temperature of CPUs and other integrated circuits having on-board temperature-sensing diodes. Use the monitor's output to reset the μP, assert an interrupt, activate a cooling fan, or trigger an external alarm.

Noise Filtering Capacitors

A quality ceramic capacitor must be connected across the DXP/DXN inputs to maintain temperature threshold accuracy by filtering out noise. The capacitor should be located physically close to the DXP/DXN pins and should typically have a value of 2200pF. Larger capacitor values can cause temperature measurement errors. A 50% variation from the recommended capacitor value can cause up to ±1°C error.

Package Information

For the latest package outline information and land patterns (footprints), go to www.maxim-ic.com/packages. Note that a "+", "#", or "-" in the package code indicates RoHS status only. Package drawings may show a different suffix character, but the drawing pertains to the package regardless of RoHS status.

PACKAGE TYPE	PACKAGE CODE	OUTLINE NO.	LAND PATTERN NO.
6 TDFN-EP	T633+2	21-0137	90-0058

Low-Cost, Remote Temperature Switch

Revision History

REVISION NUMBER	REVISION DATE	DESCRIPTION	PAGES CHANGED
2	10/04	Added the TDFN package to the <i>General Description</i> , <i>Features</i> , <i>Pin Configuration</i> , <i>Ordering Information</i> , and <i>Absolute Maximum Ratings</i> sections; added TDFN top mark codes to the <i>Device Marking Codes for SOT23-6 Package</i> table; added the TDFN package outline drawing	1, 2, 6, 8
3	2/11	Removed the MAX6511/MAX6512 parts and SOT23 packages from the data sheet; changed the leaded part to lead(Pb)-free in the <i>Ordering Information</i> table; in the <i>Absolute Maximum Ratings</i> section changed the continuous power dissipation numbers (24.4mW/°C to 18.2mW/°C and 1951mW to 1455mW), added the soldering temperature, and updated the lead temperature; added the exposed pad description to the <i>Pin Description</i> table; removed the top marks for SOT23-6 packages from the <i>Device Marking Codes for SOT23-6 Package</i> table and renamed the table; removed the <i>Chip Information</i> section; added the <i>Package Information</i> table	1-6

Maxim cannot assume responsibility for use of any circuitry other than circuitry entirely embodied in a Maxim product. No circuit patent licenses are implied. Maxim reserves the right to change the circuitry and specifications without notice at any time.

6 **Maxim Integrated Products, 120 San Gabriel Drive, Sunnyvale, CA 94086 408-737-7600**

Looking for pricing, stock, or lifecycle information?

Click below to explore more details on WIN SOURCE:

 [View MAX6513TT075+T on WIN SOURCE](#)

 [Maxim Integrated](#) Information

Optimize Your Supply Chain with WIN SOURCE Solutions

-  Global Sourcing Solution
-  Obsolete Management
-  Cost Control Management
-  Shortage Management
-  Alternative Solution
-  Excess Inventory Management