



**THE DATASHEET OF  
MAX747ESD+**





## High-Efficiency PWM, Step-Down P-Channel DC-DC Controller

MAX747

### General Description

The MAX747 high-efficiency, high-current, step-down controller drives external P-channel FETs. It provides 90% to 95% efficiency from a 6V supply with load currents ranging from 50mA up to 2.5A. It uses a pulse-width-modulating (PWM) current-mode control scheme to provide precise output regulation and low output noise. The MAX747's 4V to 15V input voltage range, a fixed 5V/adjustable (Dual-Mode™) output, and a current limit set with an external resistor make this device ideal for a wide range of applications.

High efficiency is maintained with light loads due to a proprietary dual-control (Idle-Mode™) scheme that minimizes switching losses by reducing the switching frequency at light loads. The low 800µA quiescent current and ultra-low 0.6µA shutdown current further extend battery life.

External components are protected by the MAX747's cycle-by-cycle current limit. The MAX747 also features a 2V ±1.5% reference, a comparator for low-battery detection or level translating, as well as soft-start and shutdown capability.

The MAX746, discussed in a separate data sheet, functions similarly to the MAX747, but it drives N-channel logic level FETs on the high side.

### Applications

- Notebook Power Supplies
- Personal Digital Assistants
- Battery-Operated Equipment
- Cellular Phones
- 5V to 3.3V Green PC Applications

### Pin Configuration

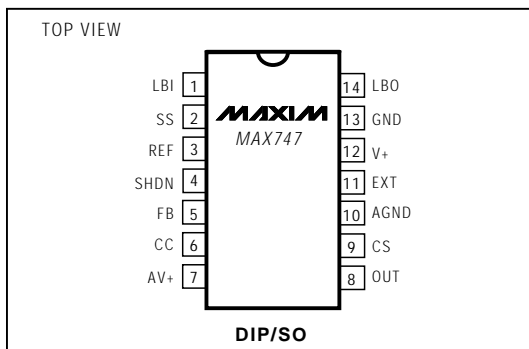

™ Dual-Mode and Idle-Mode are trademarks of Maxim Integrated Products.

### Features

- ♦ 90% to 95% Efficiency for 50mA to 2.5A Output Currents
- ♦ 4V to 15V Input Voltage Range
- ♦ Low 800µA Supply Current
- ♦ 0.6µA Shutdown Current
- ♦ Drives External P-Channel FETs
- ♦ Cycle-by-Cycle Current Limiting
- ♦ 2V ±1.5% Accurate Reference Output
- ♦ Adjustable Soft-Start
- ♦ Precision Comparator for Power-Fail or Low-Battery Warning

### Ordering Information

PART	TEMP. RANGE	PIN-PACKAGE
MAX747CPD	0°C to +70°C	14 Plastic DIP
MAX747CSD	0°C to +70°C	14 Narrow SO
MAX747C/D	0°C to +70°C	Dice*
MAX747EPD	-40°C to +85°C	14 Plastic DIP
MAX747ESD	-40°C to +85°C	14 Narrow SO
MAX747MJD	-55°C to +125°C	14 CERIDIP

\* Contact factory for dice specifications.

### Typical Operating Circuit

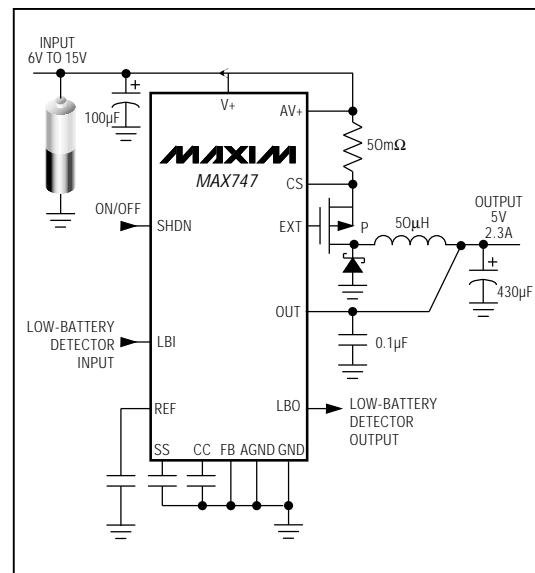

# High-Efficiency PWM, Step-Down P-Channel DC-DC Controller

MAX747

## ABSOLUTE MAXIMUM RATINGS

Supply Voltage V+, AV+ to GND	-0.3V to 17V	Operating Temperature Ranges:	
AGND to GND	-0.3V to 0.3V	MAX747C_D	0°C to +70°C
All Other Pins	-0.3V to (V+ + 0.3V)	MAX747E_D	-40°C to +85°C
Reference Current (I <sub>REF</sub> )	±2mA	MAX747MJD	-55°C to +125°C
Continuous Power Dissipation (T <sub>A</sub> = +70°C)		Junction Temperature	
Plastic DIP (derate 10.00mW/°C above +70°C)	800mW	MAX747C_D/E_D	+150°C
SO (derate 8.33mW/°C above +70°C)	667mW	MAX747MJD	+175°C
CERDIP (derate 9.09mW/°C above +70°C)	727mW	Storage Temperature Range	-65°C to +160°C
		Lead Temperature (soldering, 10sec)	+300°C

Stresses beyond those listed under "Absolute Maximum Ratings" may cause permanent damage to the device. These are stress ratings only, and functional operation of the device at these or any other conditions beyond those indicated in the operational sections of the specifications is not implied. Exposure to absolute maximum rating conditions for extended periods may affect device reliability.

## ELECTRICAL CHARACTERISTICS

(V+ = 10V, I<sub>LOAD</sub> = 0mA, I<sub>REF</sub> = 0mA, T<sub>A</sub> = T<sub>MIN</sub> to T<sub>MAX</sub>, unless otherwise noted.)

PARAMETER	SYMBOL	CONDITIONS	MIN	TYP	MAX	UNITS	
Input Voltage Range	V+	For regulated outputs	4		15	V	
Output Voltage	V <sub>OUT</sub>	V+ = 6V to 15V, 0V < V+ - CS < 0.125V, FB = 0V (includes line and load regulation)	4.85	5.08	5.25	V	
Feedback Voltage		V+ - CS = 0V, external feedback mode	MAX747C	1.96	2.00	2.04	V
			MAX747E/M	1.95	2.00	2.05	
Line Regulation		V+ = 6V to 15V, FB = 0V		0.05		%V	
		V+ = 4V to 15V, external feedback mode			0.1		
Load Regulation		0V < V+ - CS < 0.125V		1.3	2.5	%	
Efficiency		Circuit of Figure 1, I <sub>LOAD</sub> = 0.5A to 2.5A		91		%	
OUT Leakage Current		V <sub>OUT</sub> = 5V		50	80	µA	
FB Input Logic Low		For dual-mode switchover			40	mV	
FB Input Leakage Current		FB = 2V		0.1	100	nA	
Reference Voltage	V <sub>REF</sub>	I <sub>REF</sub> = 0µA	MAX747C	1.97	2.00	2.03	V
			MAX747E/M	1.96	2.00	2.04	
Reference Load Regulation		I <sub>REF</sub> = 0µA to 100µA		9	20	mV	
Soft-Start Source Current		SS = 0V		1		µA	
Soft-Start Fault Current		SS = 2V	100	500		µA	
Supply Current		Operating, V+ = 15V		0.95	1.3	mA	
		Operating, V+ = 10V		0.8			
		Shutdown mode		0.6	20		
Oscillator Frequency	f <sub>OSC</sub>	MAX747C	85	100	115	kHz	
		MAX747E/M	80	100	120		
Maximum Duty Cycle		V+ = 6V	91	96		%	
CS Amp I <sub>LIM</sub> Threshold	V <sub>LIMIT</sub>	V+ - CS	125	150	175	mV	
EXT Output High		I <sub>EXT</sub> = -1mA (sourcing)	V+ - 0.1			V	
EXT Output Low		I <sub>EXT</sub> = 1mA (sinking)			0.25	V	
EXT Sink Current		V <sub>EXT</sub> = 7.5V		110		mA	
EXT Source Current		V <sub>EXT</sub> = 2.5V		170		mA	
CC Impedance				24		kΩ	
LBI Threshold Voltage	V <sub>TH</sub>	LBI falling	MAX747C	1.97	2.00	2.03	V
			MAX747E/M	1.96	2.00	2.04	
LBO Output Voltage Low		I <sub>SINK</sub> = 0.5mA			0.4	V	
LBI Input Leakage Current		LBI = 2.5V			100	nA	
LBO Output Leakage Current		V+ = 15V, LBO = 15V, LBI = 2.5V			1	µA	
SHDN Input Voltage Low	V <sub>IL</sub>				0.4	V	
SHDN Input Voltage High	V <sub>IH</sub>		2.0			V	
SHDN Input Leakage Current		SHDN = 10V		0.1	100	nA	

# High-Efficiency PWM, Step-Down P-Channel DC-DC Controller

## Typical Operating Characteristics

(Circuit of Figure 1,  $V_+ = 9V$ ,  $T_A = +25^\circ C$ , unless otherwise noted.)

MAX747

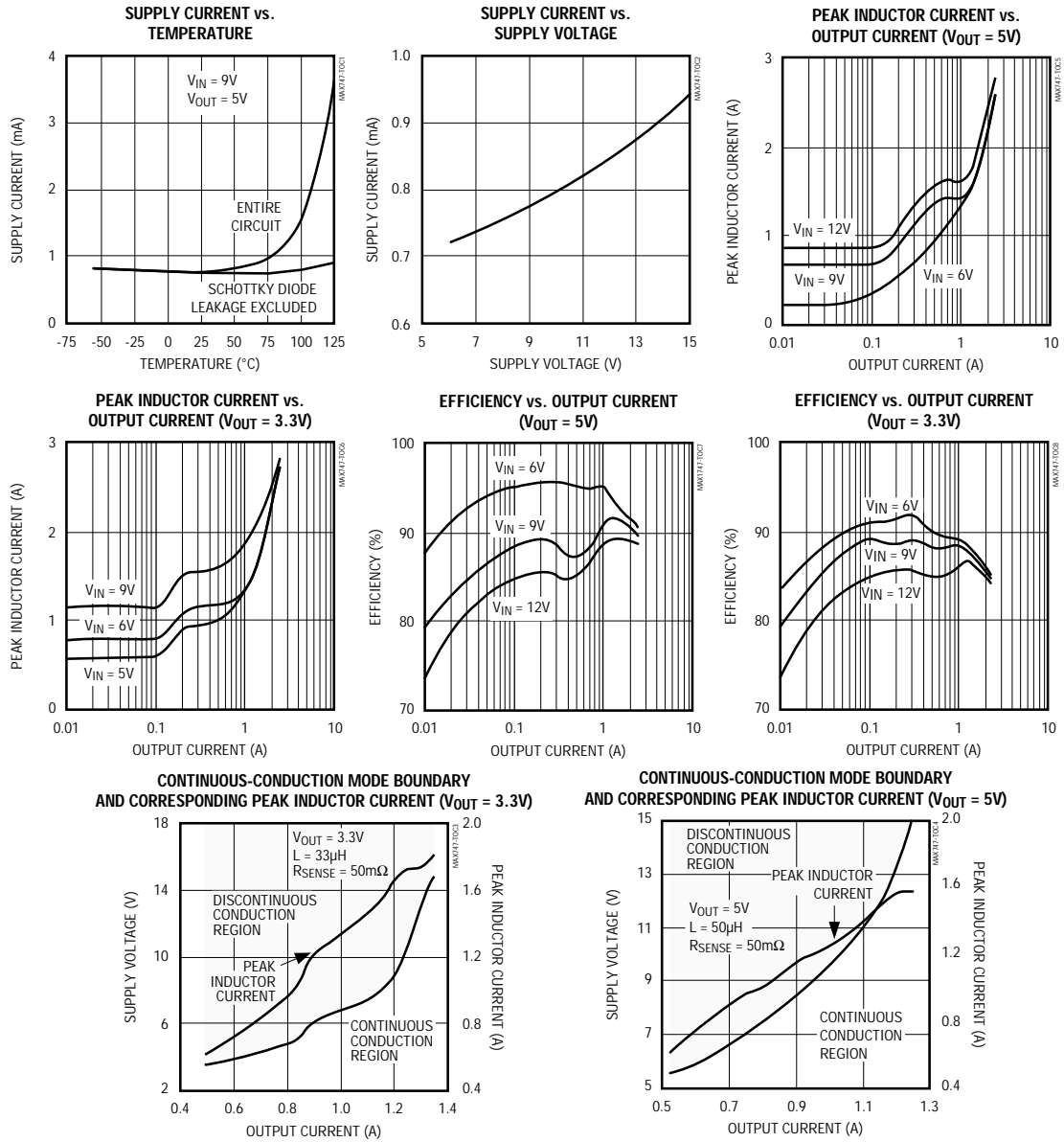

# High-Efficiency PWM, Step-Down P-Channel DC-DC Controller

## Typical Operating Characteristics (continued)

### CONTINUOUS-CONDUCTION MODE WAVEFORMS

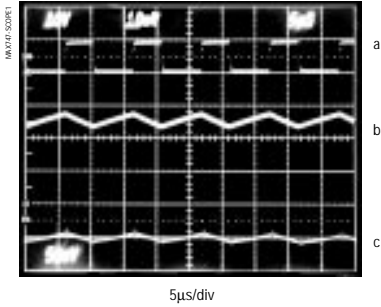

$V_+ = 9V, I_{OUT} = 2.5A$   
 a) EXT VOLTAGE, 10V/div  
 b) INDUCTOR CURRENT, 1A/div  
 c)  $V_{OUT}$  RIPPLE, 50mV/div

### DISCONTINUOUS-CONDUCTION IDLE-MODE WAVEFORMS

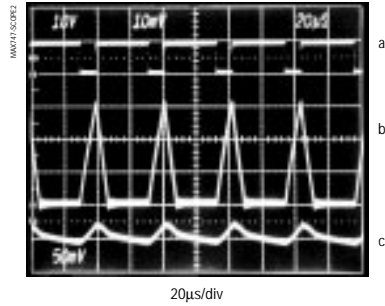

$V_+ = 9V, I_{OUT} = 125mA$   
 a) EXT VOLTAGE, 10V/div  
 b) INDUCTOR CURRENT, 200mA/div  
 c)  $V_{OUT}$  RIPPLE, 50mV/div

### LINE-TRANSIENT RESPONSE

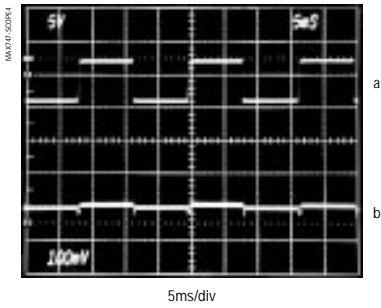

$I_{OUT} = 2.0A$   
 a)  $V_+ = 6V$  to  $12V$ , 5V/div  
 b)  $V_{OUT}$  RIPPLE, 100mV/div

### LOAD-TRANSIENT RESPONSE

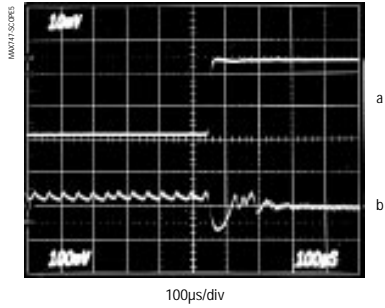

$V_+ = 9V, C_{OUT} = 430\mu F$   
 a) LOAD CURRENT, 0.1A TO 2.5A, 1A/div  
 b)  $V_{OUT}$  RIPPLE, 100mV/div

### MODERATE LOAD, IDLE-MODE WAVEFORMS

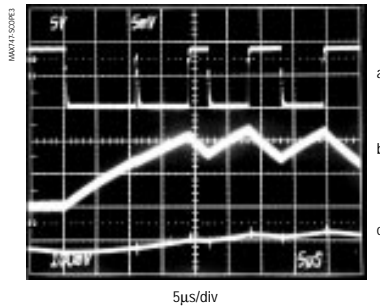

$V_+ = 9V, I_{OUT} = 560mA$   
 a) EXT VOLTAGE, 5V/div  
 b) INDUCTOR CURRENT, 0.5A/div  
 c)  $V_{OUT}$  RIPPLE 100mV/div

# High-Efficiency PWM, Step-Down P-Channel DC-DC Controller

MAX747

## Pin Description

PIN	NAME	FUNCTION
1	LBI	Input to the internal low-battery comparator. Tie to V+ or GND if not used.
2	SS	Soft-start limits start-up surge currents. On power-up, it charges the soft-start capacitor, slowly raising the peak current limit to the level set by the sense resistor.
3	REF	2V reference output that can source 100 $\mu$ A for external loads. Bypass with 0.22 $\mu$ F. The reference is disabled in shutdown mode.
4	SHDN	Active-high TTL/CMOS logic-level input. In shutdown mode, V <sub>OUT</sub> = 0V and the supply current is reduced to 20 $\mu$ A.
5	FB	Feedback input for adjustable-output operation. Connect to GND for fixed +5V output. Use a resistor divider network to adjust the output voltage. See the section <i>Setting the Output Voltage</i> .
6	CC	Compensation capacitor. AC compensation input for the error amplifier. Connect a capacitor between CC and GND for fixed +5V output operation. See <i>Compensation Capacitor</i> section.
7	AV+	Quiet supply voltage for sensitive analog circuitry. A bypass capacitor is not required for AV+.
8	OUT	Output voltage sense input. Connects to internal resistor divider. Leave unconnected for adjustable output. Bypass to AGND with a 0.1 $\mu$ F capacitor close to the IC.
9	CS	Negative input to the current-sense amplifier. Connect the current-sense resistor (R <sub>SENSE</sub> ) from V+ to CS.
10	AGND	Quiet analog ground
11	EXT	Power MOSFET gate drive output that swings between V+ and GND. EXT is not protected against short circuits to V+ or AGND.
12	V+	High-current supply voltage for the output driver
13	GND	High-current ground return for the output driver
14	LBO	Low-battery output is an open-drain output that goes low when LBI is less than 2V. Connect to V+ through a pull-up resistor. Leave floating if not used. LBO is disabled in shutdown mode.

## Getting Starting

Figure 1a shows the 5V output 11.4W standard application circuit and Figure 1b shows the 3.3V output 7.5W standard application circuit. Most applications will be served by these circuits. To learn more about component selection for particular applications, refer to the *Design Procedure* section. To learn more about the operation of the MAX747, refer to the *Detailed Description*.

## Detailed Description

The MAX747 monolithic, CMOS, step-down switch-mode power-supply controller drives external P-channel FETs. It uses a unique current-mode pulse-width-modulating (PWM) control scheme that results in high efficiency over a wide range of load currents, tight output voltage regulation, excellent load- and line-transient response, and low noise. Efficiency at light loads is further enhanced by a proprietary Idle-Mode switching control scheme that skips oscillator cycles in order to reduce switching losses.

## High-Efficiency PWM, Step-Down P-Channel DC-DC Controller

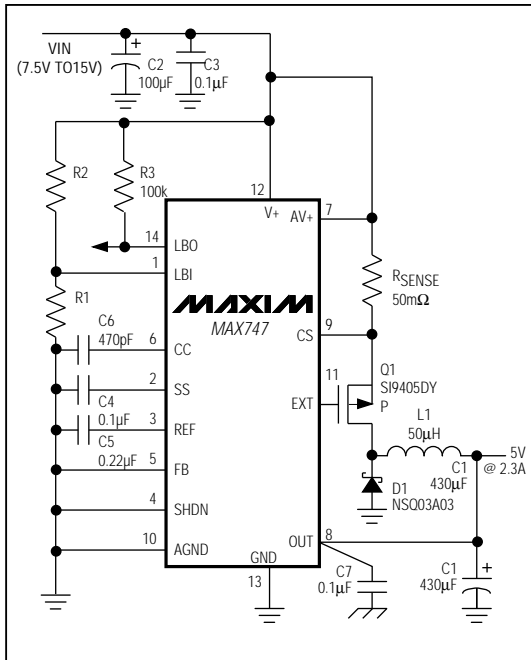

Figure 1a. +5V Standard Application Circuit

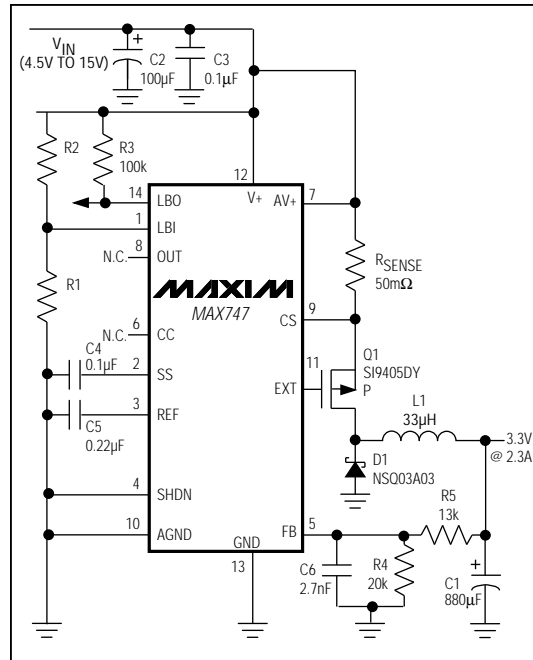

Figure 1b. +3.3V Standard Application Circuit

### Operating Principle

Figure 2 is the MAX747 block diagram. The MAX747 regulates using an inner current-feedback loop and an outer voltage-feedback loop. The current loop is stabilized by a slope compensation scheme and the voltage loop is stabilized by the dominant pole formed by the filter output capacitor and the load.

### Discontinuous-/Continuous-Conduction Modes

The MAX747 operates in continuous-conduction mode (CCM) under heavy loads, but operates in discontinuous-conduction mode (DCM) at light loads, making it ideal for variable load applications. In DCM, the inductor current starts and ends at zero on each cycle. In CCM, the inductor current never returns to zero. It is composed of a small AC component superimposed on a DC level, which results in higher load-current capability and lower output noise. Output noise is reduced because the inductor does not exhibit the ringing that occurs when the inductor current reaches zero, and because there is a smaller AC component in the inductor-current waveform (see inductor waveforms in the *Typical Operating Characteristics* section). Note

that to transfer equal amounts of energy to the load in one cycle, the peak current level for the discontinuous waveform must be much larger than the continuous waveform peak current.

### Slope Compensation

Stability of the inner current-feedback loop is provided by a slope-compensation scheme that adds a ramp signal to the current-sense amplifier output. Ideal slope compensation can be achieved by adding a linear ramp with the same slope as the **declining** inductor current to the rising inductor current-sense voltage. Therefore, the inductor must be scaled to the current-sense resistor value.

Overcompensation adds a pole to the outer voltage-feedback loop response that degrades loop stability. This may cause voltage-mode pulse-frequency-modulation instead of PWM operation. Undercompensation results in inner current-feedback loop instability, and may cause the inductor current to staircase. Ideal matching between the sense resistor and inductor is not required. The matching can be  $\pm 30\%$  or more.

# High-Efficiency PWM, Step-Down P-Channel DC-DC Controller

MAX747

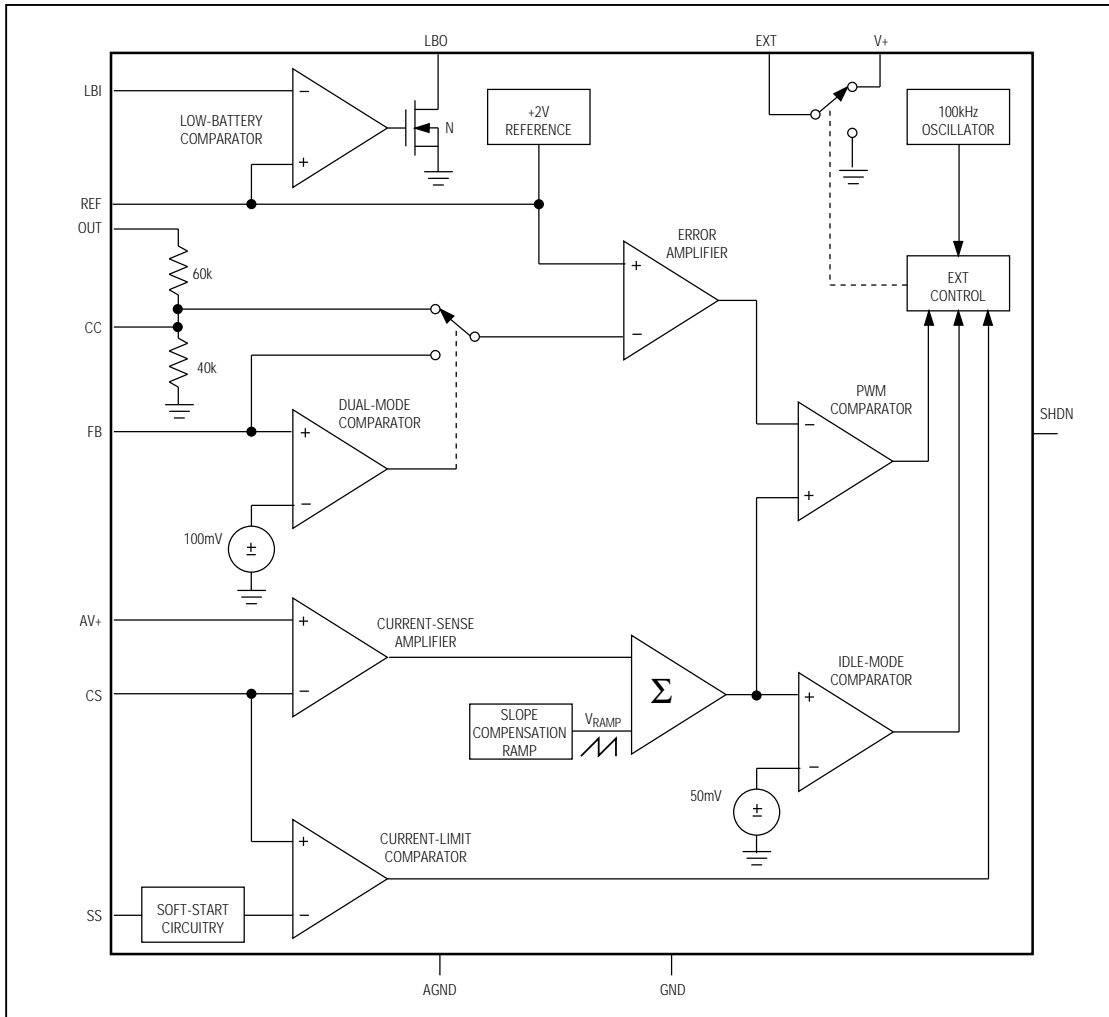

Figure 2. Block Diagram

### The Oscillator and EXT Control

The switching frequency is nominally 100kHz and the duty cycle varies from 5% to 96%, depending on the input/output voltage ratio. EXT, which provides the gate drive for the external P-FET, is switched between V+ and GND at the switching frequency. EXT is controlled by a unique two-comparator control scheme composed of a PWM comparator and an idle-mode comparator

(Figure 2). The PWM comparator determines the cycle-by-cycle peak current with heavy loads, and the light-load comparator sets the light-load peak current. As  $V_{OUT}$  begins to drop, EXT goes low and remains low until both comparators trip. With heavy loads, the idle-mode comparator trips quickly, and the PWM control comparator determines the EXT on-time; with light loads, the idle-mode comparator sets the EXT on-time.

## High-Efficiency PWM, Step-Down P-Channel DC-DC Controller

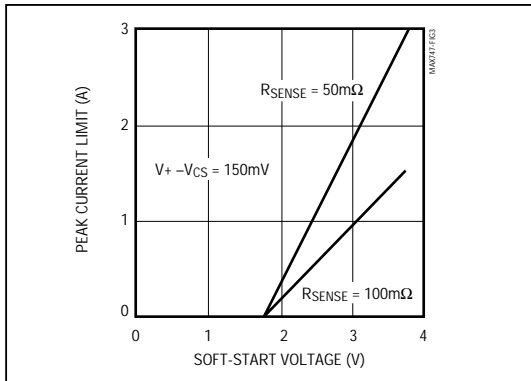

Figure 3. Peak Current Limit vs. Soft-Start Voltage

With decreasing loads, as the inductor current becomes discontinuous, traditional PWM converters continue to switch at a fixed frequency, decreasing light-load efficiency. However, the MAX747's idle-mode comparator increases the peak inductor current, allowing more energy to be transferred per cycle. Since fewer cycles are required, the switching frequency is reduced. This keeps the external P-FET off for longer periods, minimizing switching losses and increasing efficiency.

The light-load output noise spectrum widens due to variable switching frequency in idle-mode, but output ripple remains low. Using the *Typical Operating Circuit*, with a 9V input and a 125mA load current, output ripple is less than 40mV.

### Soft-Start and Current Limiting

The MAX747 draws its highest current at power-up. If the power source to the MAX747 cannot provide this initial elevated current, the circuit may not function correctly. For example, after prolonged use, a battery's increased series resistance may prevent it from providing adequate initial surge currents when the MAX747 is brought out of shutdown. Using Soft-Start (SS) minimizes the possibility of overloading the incoming supply at power-up by gradually increasing the peak current limit. Connect an external capacitor from SS to ground to reduce the initial peak currents drawn from the supply.

The steady-state SS pin voltage is typically 3.8V. On power-up, SS sources 1μA until the SS voltage reaches 3.8V. The current-limit comparator inhibits EXT switching until the SS voltage reaches 1.8V. The maximum current limit is set by:

$$I_{PK} = \frac{V_{LIMIT}}{R_{SENSE}} = \frac{150\text{mV (typ)}}{R_{SENSE}}$$

Figure 3 shows how the peak current limit increases as the voltage on SS rises for two  $R_{SENSE}$  values.

### Shutdown Mode

When SHDN is high, the MAX747 enters shutdown mode. In this mode, the internal biasing circuitry (including EXT) is turned off,  $V_{OUT}$  drops to 0V, and the supply current drops to 0.6μA (20μA max). This excludes external component leakage, which may add several microamps to the shutdown supply current for the entire circuit. SHDN is a TTL/CMOS logic-level input. Connect SHDN to GND for normal operation.

### Low-Battery Detector

The MAX747 provides a low-battery comparator that compares the voltage on LBI to the reference voltage. LBO, an open-drain output, goes low when the LBI voltage is below  $V_{REF}$ . Use a resistor-divider network as shown in Figure 4 to set the trip voltage ( $V_{TRIP}$ ) to the desired level. In this circuit, LBO goes low when  $V+ \leq V_{TRIP}$ . LBO is high impedance in shutdown mode.

## Design Procedure

### Setting the Output Voltage

The MAX747's output voltage can be set to 5V by grounding FB, or adjusted from 2V to 14V using external resistors R4 and R5, configured as shown in Figure 5. Select feedback resistor R4 from the 10kΩ to 1MΩ range. R5 is given by:

$$R5 = (R4) \left[ \frac{V_{OUT}}{2V} - 1 \right]$$

### Selecting R\_SENSE

First, approximate the peak current assuming  $I_{PK}$  is  $(1.1)(I_{LOAD})$ , where  $I_{LOAD}$  is the maximum load current. Once all component values have been determined, the actual peak current is given by:

$$I_{PK} = I_{LOAD} + \left[ \frac{V_{OUT}}{(2L)(f_{OSC})} \right] \left( 1 - \frac{V_{OUT}}{V_{IN}} \right)$$

Next, determine the value of  $R_{SENSE}$  such that:

$$R_{SENSE} = \frac{V_{LIMIT(MIN)}}{I_{PK}} = \frac{125\text{mV}}{I_{PK}}$$

For example, to obtain 5V at 3A,  $I_{PK} = 3.3\text{A}$  and  $R_{SENSE} = 125\text{mV}/3.3\text{A} = 38\text{m}\Omega$ .

The sense resistor should have a power rating greater than  $(I_{PK}^2)(R_{SENSE})$  (with an adequate safety margin). With a 3A load current,  $I_{PK} = 3.3\text{A}$  and  $R_{SENSE} = 38\text{m}\Omega$ . The power dissipated by the resistor (assuming an 80%

## High-Efficiency PWM, Step-Down P-Channel DC-DC Controller

duty cycle) is 331mW. Metal film resistors are recommended. Do not use wire-wound resistors because their inductance will adversely affect circuit operation.

Determine the duty cycle for CCM from the following equation:

$$\text{Duty cycle (\%)} = \left( \frac{V_{\text{OUT}} + V_{\text{DIODE}}}{V_+ - V_{\text{SW}} + V_{\text{DIODE}}} \right) (100\%)$$

where  $V_{\text{SW}}$  is the voltage drop across the external P-FET and sense resistor, and can be approximated as  $(I_{\text{LOAD}})[R_{\text{DS(ON)}} + R_{\text{SENSE}}]$ .

### Inductor Selection

Once the sense resistor value is determined, the inductor is determined from the following equation. The value of inductor L ensures proper slope compensation. Continuing with the above example,

$$\begin{aligned} L &= \frac{(R_{\text{SENSE}}) (V_{\text{OUT(MAX)}})}{(V_{\text{RAMP(MAX)}}) (f_{\text{OSC}})} \\ &= \frac{(38\text{m}\Omega) (5\text{V})}{(50\text{mV}) (100\text{kHz})} = 38\mu\text{H} \end{aligned}$$

Although 38μH is the calculated value, the component used may have a tolerance of ±30% or more. Make sure the inductor's saturation current rating (the current at which the core begins to saturate and the inductance starts to fall) exceeds the peak current set by  $R_{\text{SENSE}}$ .

Inductors with molypermalloy powder (MPP), Kool Mμ, or ferrite are recommended. Inexpensive iron powder core inductors are not suitable due to their increased core losses. MPP and Kool Mμ cores have low permeability, allowing larger currents.

For highest efficiency, use a coil with low DC resistance. To minimize radiated noise, use a toroid, pot core, or shielded coil.

### External P-FET Selection

To ensure the external P-FET is fully on, use logic-level, or low threshold P-FETs when the minimum input voltage is less than 8V.

When selecting the P-FET, three important parameters to note are total gate charge ( $Q_g$ ), on resistance ( $R_{\text{DS(ON)}}$ ), and reverse transfer capacitance ( $C_{\text{RSS}}$ ).

$Q_g$ , the total gate charge, includes all capacitances associated with charging the gate. Use the typical  $Q_g$  value for best results; the maximum value is usually overspecified since it is a guaranteed limit and not the measured value. The typical total gate charge should be ≤ 50nC. Larger numbers mean that EXT may not be able to adequately drive the gate. EXT sink/source capability ( $I_{\text{EXT}}$ ) is typically 140mA.

There are two losses associated with the P-FET's power dissipation:  $I^2R$  losses and switching losses. CCM power dissipation (PD) is approximated by:

$$\text{PD} = (\text{Duty Cycle}) \left( I_{\text{PK}}^2 \right) \left[ R_{\text{DS(ON)}} \right] + \left[ \frac{(V_+)^2 (C_{\text{RSS}}) (I_{\text{PK}}) (f_{\text{OSC}})}{I_{\text{EXT}}} \right]$$

where the duty cycle is approximated by  $V_{\text{OUT}}/V_+$ ,  $f_{\text{OSC}} = 100\text{kHz}$ , and  $R_{\text{DS(ON)}}$  and  $C_{\text{RSS}}$  are given in the data sheet of the chosen P-FET. In the equation,  $R_{\text{DS(ON)}}$  is assumed to be constant, but is actually a function of temperature. Note that the equation does not account for losses incurred by charging and discharging the

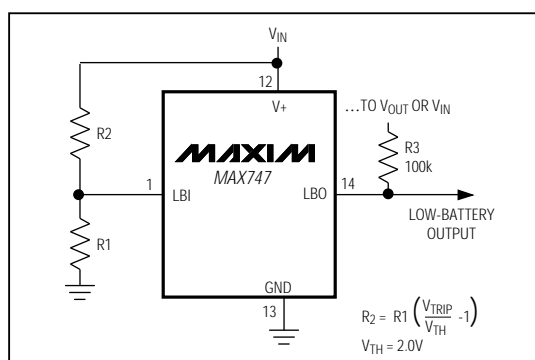

Figure 4. Input Voltage Monitor Circuit

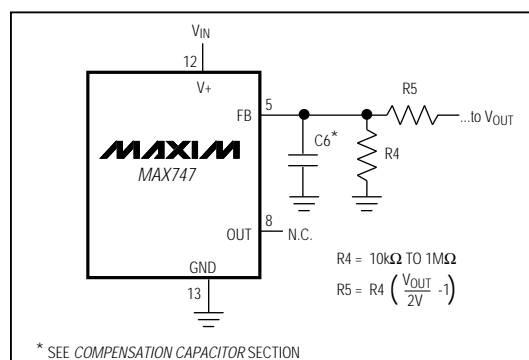

Figure 5. Adjustable Output Circuit

## High-Efficiency PWM, Step-Down P-Channel DC-DC Controller

gate capacitance, because that energy is dissipated by the gate-drive circuitry, not the P-FET.

The *Standard Application Circuit* (Figure 1a, 1b) uses an 8-pin Si9405DY surface-mount P-FET that has  $0.1\Omega$  on resistance with a  $10V V_{GS}$ . Optimum efficiency is obtained when the voltage at the drain swings between the supply rails (within a few hundred mV).

### Diode Selection

The MAX747's high switching frequency demands a high-speed rectifier. Schottky diodes are recommended. Ensure that the Schottky diode average current rating exceeds the load current level.

### Capacitor Selection

#### Output Filter Capacitor

The output filter capacitor C1 should have a low effective series resistance (ESR), and its capacitance should remain fairly constant over temperature. This is especially true when in CCM, since the output filter capacitor and the load form the dominant pole that stabilizes the loop.  $430\mu F$  is adequate for load currents up to 2.3A in Figure 1a. At low input/output differentials, it may be necessary to use much larger output filter capacitors to maintain adequate load-transient response. See the *AC Stability with Low Input/Output Differentials* section.

Sprague 595D surface-mount solid tantalum capacitors and Sanyo OS-CON through-hole capacitors are recommended due to their extremely low ESR. OS-CON capacitors are particularly useful at low temperatures.

For best results when using other capacitors, increase the output filter capacitor's size or use capacitors in parallel to reduce ESR.

#### Input Bypass Capacitor

The input bypass capacitor C2 reduces peak currents drawn from the voltage source, and also reduces noise at the voltage source caused by the MAX747's fast switching action (this is especially important when other circuitry is operated from the same source). The input capacitor ripple current rating must exceed the RMS input current.

$$I_{RMS} = \text{RMS AC input current}$$

$$= I_{LOAD} \left[ \frac{\sqrt{V_{OUT}(V_{IN} - V_{OUT})}}{V_{IN}} \right]$$

For load currents up to 2.5A,  $100\mu F$  (C2) in parallel with a  $0.1\mu F$  (C3) is adequate. Smaller bypass capacitors may be acceptable for lighter loads. The input voltage source impedance determines the capacitor size

required at the V+ input. As with the output filter capacitor, a low-ESR capacitor (Sanyo OS-CON, Sprague 595D, or equivalent) is recommended for input bypassing.

#### Soft-Start and Reference Capacitors

A typical value for the soft-start capacitor C4 is  $0.1\mu F$ , which provides a 380ms ramp to full current limit. Use values in the  $0.001\mu F$  and  $1\mu F$  range. The nominal time for C4 to reach its steady-state value is given by:

$$t_{SS} (\text{sec}) = (C4) (3.8 \times 10^6)$$

Note that  $t_{SS}$  does **not** equal the time it takes for the MAX747 to power up, although it does affect start-up time. Start-up time is also a function of the input voltage and load current. With a 2.5A load current, a 7V input voltage, and a  $0.1\mu F$  soft-start capacitor, power-up takes typically 360ms.

Bypass REF with a  $0.22\mu F$  capacitor (C5).

#### Compensation Capacitor

With a fixed +5V output, connect the compensation capacitor (C6) between CC and GND to optimize transient response. Appropriate compensation is determined by the ESR of the output filter capacitor (C1) and the feedback voltage-sense resistor network.  $270pF$  is adequate for applications where  $V+ \leq 9V$ . Over the full input voltage range, increase C6 to  $470pF$ . C6 also depends on the load current, so for light loads, C6's value can be reduced. If appropriate compensation is not obtained using  $470pF$ , use the following equations to determine C6:

For fixed 5V output operation,

$$C6 = \frac{(C1) (ESR_{C1})}{24k\Omega}$$

**For adjustable-output operation, FB becomes the compensation input pin and CC is left unconnected. Connect C6 between FB and GND in parallel with R4 (Figure 5). C6 is determined by:**

$$C6 = \frac{(C1) (ESR_{C1})}{R4 \parallel R5}$$

For example, with a fixed 5V output,  $C1 = 330\mu F$  and an  $ESR_{C1}$  of  $0.04\Omega$  (at a 100kHz frequency),

$$C6 = \frac{(C1) (ESR_{C1})}{24k\Omega} = 783pF$$

# High-Efficiency PWM, Step-Down P-Channel DC-DC Controller

MAX747

## Setting the Low-Battery Detector Voltage

Select R1 between 10kΩ and 1MΩ.

$$R2 = R1 \left[ \frac{(V_{TRIP} - V_{REF})}{V_{REF}} \right]$$

Connect a pull-up resistor (e.g., 100kΩ) between LBO and V<sub>OUT</sub> (Figure 4).

## Applications Information

### Layout Considerations

Due to high current levels and fast switching waveforms, which radiate noise, proper MAX747 PC board layout is essential. Protect sensitive analog grounds by using a star ground configuration. Use an adequate ground plane and minimize ground noise by connecting GND, the anode of the steering Schottky diode, the input bypass capacitor ground lead, and the output filter capacitor ground lead to a single point (star ground configuration). Also, minimize lead lengths to minimize stray capacitance, trace resistance, and radiated noise. Place bypass capacitor C3 as close as possible to V+ and GND.

AV+ and CS are the inputs to the differential-input current-sense amplifier. Use a Kelvin connection across the sense resistor as shown in Figure 6. Note that even though AV+ also functions as the supply voltage for sensitive analog circuitry, a separate AV+ bypass capacitor should not be used. By not using a capacitor, any noise appearing at the CS input will also appear at the AV+ input and will appear as a common-mode signal to the current-sense amplifier. A separate AV+ capacitor causes the noise to appear only on one input, and this differential noise will be amplified, adversely affecting circuit operation.

Similarly, CC (or FB in adjustable-output operation) is a sensitive input that should not be shorted to any node. Avoid shorting CC when probing the circuit, as this may damage the device.

### Switching Waveforms

A region exists between CCM and DCM where the inductor current operates in both modes, as shown in the Idle-Mode Moderate current EXT waveform in the *Typical Operating Characteristics*. As the output voltage varies, it is fed back into CC and the duty cycle is adjusted to compensate for this change. The switch is considered off when V<sub>EXT</sub> ≤ the P-FET's V<sub>GS</sub> threshold voltage. Once the switch is off, the voltage at EXT is pulled to V+ and the P-FET drain voltage is a Schottky diode drop below GND. However, in this "in-

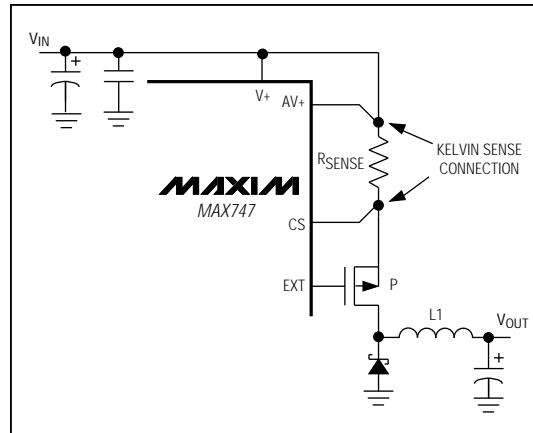

Figure 6. Kelvin Connection for Current-Sense Amplifier

between" mode (due to the changing duty cycle inherent with DCM), when the device is at maximum duty cycle, EXT turns off at V+ - V<sub>GS</sub>. But it is not always pulled to V+ because the switch sometimes turns on again after a minimum off-time before EXT can be pulled to V+. The result is short spikes that appear on the EXT waveform in the *Typical Operating Characteristics*.

### AC Stability with Low Input/Output Differentials

At low input/output differentials, the inductor current cannot slew quickly to respond to load changes, so the output filter capacitor must hold up the voltage as the load transient is applied. In Figure 1a's circuit, for V+ = 6.5V, increase the output filter capacitor to 700μF (Sprague 595D low-ESR capacitors) to obtain a transient response less than 250mV with a load step from 200mA to 2.5A. For V+ = 6V and V<sub>OUT</sub> = 5V, increase the output filter capacitor to approximately 1000μF. As V+ increases, the device will no longer be operating near full duty cycle with light loads, allowing it to adjust to full duty cycle when the load transient is applied and, in turn, allowing smaller output filter capacitors to be used.

### Dual-Mode Operation

The MAX747 is designed in either fixed-output mode (5V-output, FB = GND) or in adjustable mode (FB = 2V) using a resistor divider. It is not designed to be switched from one mode to another when powered up; however, in adjustment mode, switching between two different resistor dividers is acceptable.

# High-Efficiency PWM, Step-Down P-Channel DC-DC Controller

## Additional Notes

When probing the MAX747 circuit, avoid shorting AV+ to GND (the two pins are adjacent to each other) as this may cause the IC to malfunction due to large ground currents. Also, the MAX747 may continue to operate with AV+ disconnected, but erratic switching waveforms will appear at EXT. Finally, due to its fast switching and high drive capability requirements, EXT is a low-impedance point that is not short-circuit protected. Therefore, do not short EXT to any node (including AGND and V+, which are adjacent to EXT) to prevent damaging the device.

**Table 1. Component Suppliers**

SUPPLIER	PHONE	FAX
<b>INDUCTORS</b>		
Coiltronics	(305) 781-8900	(305) 782-4163
Gowanda	(716) 532-2234	(716) 532-2702
Sumida USA	(708) 956-0666	(708) 956-0702
Sumida Japan	81-3-3607-511	81-3-3607-5428
<b>CAPACITORS</b>		
Kemet	(803) 963-6300	(803) 963-6322
Matsuo	(714) 969-2491	(714) 960-6492
Nichicon	(708) 843-7500	(708) 843-2798
Sprague	(603) 224-1961	(603) 224-1430
Sanyo USA	(619) 661-6322	
Sanyo Japan	81-3-3837-6242	
United Chemi-Con	(714) 255-9500	(714) 255-9400
<b>DIODES</b>		
Motorola	(800) 521-6274	
Nihon USA	(805) 867-2555	(805) 867-2698
Nihon Japan	81-3-3494-7411	81-3-3494-7414
<b>POWER TRANSISTORS</b>		
Harris	(407) 724-3739	(407) 724-3937
International Rectifier	(213) 772-2000	(213) 772-9028
Siliconix	(408) 988-8000	(408) 727-5414
<b>RESISTORS</b>		
IRC	(512) 992-7900	(512) 992-3377

## Chip Topography

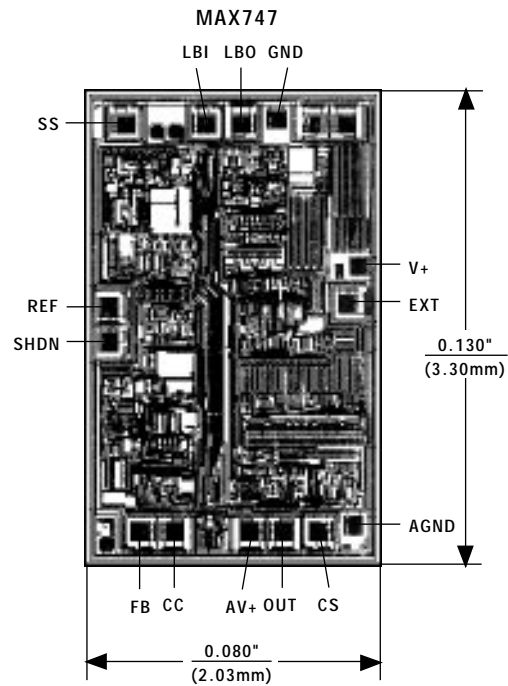

SUBSTRATE CONNECTED TO V+;  
TRANSISTOR COUNT: 508.

Maxim cannot assume responsibility for use of any circuitry other than circuitry entirely embodied in a Maxim product. No circuit patent licenses are implied. Maxim reserves the right to change the circuitry and specifications without notice at any time.

12 \_\_\_\_\_ Maxim Integrated Products, 120 San Gabriel Drive, Sunnyvale, CA 94086 (408) 737-7600

## Looking for pricing, stock, or lifecycle information?

Click below to explore more details on WIN SOURCE:

 [View MAX747ESD+ on WIN SOURCE](#)

 [Maxim Integrated](#) Information

## Optimize Your Supply Chain with WIN SOURCE Solutions

-  Global Sourcing Solution
-  Obsolete Management
-  Cost Control Management
-  Shortage Management
-  Alternative Solution
-  Excess Inventory Management