



**THE DATASHEET OF  
MB90F352SPFM-GS-DE1**



# 16-bit Proprietary Microcontroller

CMOS

## F<sup>2</sup>MC-16LX MB90350 Series

MB90F351(S), MB90F352(S), MB90F351A(S), MB90F351TA(S), MB90F352A(S), MB90F352TA(S), MB90F356A(S), MB90F356TA(S), MB90F357A(S), MB90F357TA(S), MB90351A(S), MB90351TA(S), MB90352A(S), MB90352TA(S), MB90356A(S), MB90356TA(S), MB90357A(S), MB90357TA(S), MB90V340A-101/102/103/104

### ■ DESCRIPTION

The MB90350-series with 1 channel FULL-CAN\* interface and Flash ROM is especially designed for automotive and industrial applications. Its main feature is the on-board CAN interface, which conforms to V2.0 Part A and Part B, while supporting a very flexible message buffer scheme and so offering more functions than a normal full CAN approach. With the new 0.35 μm CMOS technology, Fujitsu now offers on-chip Flash-ROM program memory up to 128 Kbytes.

The power supply (3 V) is supplied to the internal MCU core from an internal regulator circuit. This creates a major advantage in terms of EMI and power consumption.

The internal PLL clock frequency multiplier provides an internal 42 ns instruction execution time from an external 4 MHz clock. Also, the clock monitor function can monitor main clock and sub clock independently.

As the peripheral resources, the unit features a 4-channel Output Compare Unit, 6-channel Input Capture Unit, 2 separate 16-bit freerun timers, 2-channel UART and 15-channel 8/10-bit A/D converter.

\* : Controller Area Network (CAN) - License of Robert Bosch GmbH

Note : F<sup>2</sup>MC stands for FUJITSU Flexible Microcontroller, a registered trademark of FUJITSU LIMITED.

### ■ PACKAGES

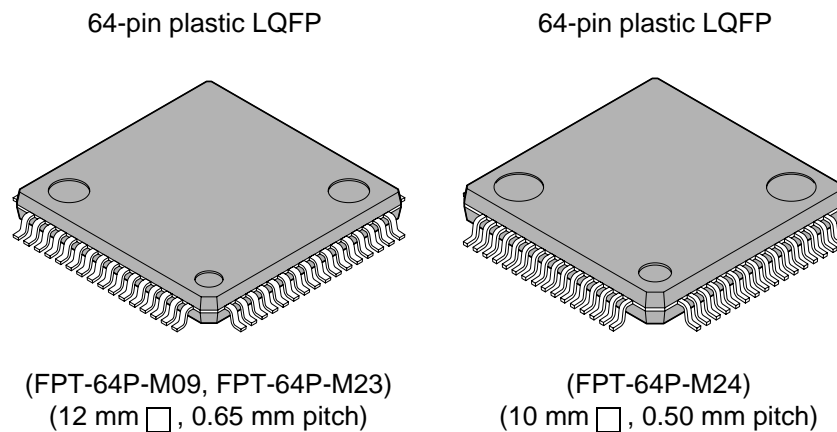

# MB90350 Series

## ■ FEATURES

### • Clock

- Built-in PLL clock frequency multiplication circuit
- Selection of machine clocks (PLL clocks) is allowed among frequency division by two on oscillation clock, and multiplication of 1 to 6 times of oscillation clock (for 4 MHz oscillation clock, 4 MHz to 24 MHz).
- Operation by sub clock (up to 50 kHz : 100 kHz oscillation clock divided by two) is allowed. (devices without S-suffix only)
- Minimum execution time of instruction : 42 ns (when operating with 4-MHz oscillation clock, and 6-time multiplied PLL clock).
- Built-in clock modulation circuit

### • 16 Mbytes CPU memory space

- 24-bit internal addressing

### • Clock monitor function (MB90x356x and MB90x357x only)

- Main clock or sub clock is monitored independently.
- Internal CR oscillation clock (100 kHz typical) can be used as sub clock.

### • Instruction system best suited to controller

- Wide choice of data types (bit, byte, word, and long word)
- Wide choice of addressing modes (23 types)
- Enhanced multiply-divide instructions with sign and RETI instructions
- Enhanced high-precision computing with 32-bit accumulator

### • Instruction system compatible with high-level language (C language) and multitask

- Employing system stack pointer
- Enhanced various pointer indirect instructions
- Barrel shift instructions

### • Increased processing speed

- 4-byte instruction queue

### • Powerful interrupt function

- Powerful 8-level, 34-condition interrupt feature
- Up to 8 channels external interrupts are supported.

### • Automatic data transfer function independent of CPU

- Extended intelligent I/O service function (EI<sup>2</sup>OS) : up to 16 channels
- DMA : up to 16 channels

### • Low power consumption (standby) mode

- Sleep mode (a mode that halts CPU operating clock)
- Main timer mode (a timebase timer mode switched from the main clock mode)
- PLL timer mode (a timebase timer mode switched from the PLL clock mode)
- Watch mode (a mode that operates sub clock and watch timer only)
- Stop mode (a mode that stops oscillation clock and sub clock)
- CPU intermittent operation mode

### • Process

- CMOS technology

(Continued)

- **I/O port**
  - General-purpose input/output port (CMOS output)
    - 49 ports (devices without S-suffix : devices that correspond to sub clock)
    - 51 ports (devices with S-suffix : devices that do not correspond to sub clock)
- **Sub clock pin (X0A, X1A)**
  - Yes (using the external oscillation) : devices without S-suffix
  - No (using the sub clock mode at internal CR oscillation) : devices with S-suffix
- **Timer**
  - Timebase timer, watch timer, watchdog timer : 1 channel
  - 8/16-bit PPG timer : 8-bit × 10 channels or 16-bit × 6 channels
  - 16-bit reload timer : 4 channels
  - 16-bit input/output timer
    - 16-bit freerun timer : 2 channels (FRT0 : ICU0/1, FRT1 : ICU 4/5/6/7, OCU 4/5/6/7)
    - 16-bit input capture: (ICU) : 6 channels
    - 16-bit output compare : (OCU) : 4 channels
- **FULL-CAN interface : 1 channel**
  - Compliant with Ver2.0 part A and Ver2.0 part B CAN specifications
  - Flexible message buffering (mailbox and FIFO buffering can be mixed)
  - CAN wake-up function
- **UART (LIN/SCI) : 2 channels**
  - Equipped with full-duplex double buffer
  - Clock-asynchronous or clock-synchronous serial transmission is available.
- **I<sup>2</sup>C interface\* : 1 channel**
  - Up to 400 Kbit/s transfer rate
- **DTP/External interrupt : 8 channels, CAN wakeup : 1 channel**
  - Module for activation of extended intelligent I/O service (EI<sup>2</sup>OS), DMA, and generation of external interrupt by external input.
- **Delay interrupt generator module**
  - Generates interrupt request for task switching.
- **8/10-bit A/D converter : 15 channels**
  - Resolution is selectable between 8-bit and 10-bit.
  - Activation by external trigger input is allowed.
  - Conversion time : 3 μs (at 24-MHz machine clock, including sampling time)
- **Program patch function**
  - Address matching detection for 6 address pointers.
- **Capable of changing input voltage level for port**
  - Automotive/CMOS-Schmitt (initial level is Automotive in single chip mode)
  - TTL level (corresponds to external bus pins only, initial level of these pins is TTL in external bus mode)
- **Low voltage/CPU operation detection reset (devices with T-suffix)**
  - Detects low voltage (4.0 V ± 0.3 V) and resets automatically
  - Resets automatically when program is runaway and counter is not cleared within interval time (approx. 262 ms : external 4 MHz)

(Continued)

# MB90350 Series

(Continued)

- **Dual operation flash memory (only flash memory devices with A-suffix)**

- Erase/write and read can be executed in the different bank (Upper Bank/Lower Bank) at the same time.

- **Models that support + 125 °C**

- Devices without A-suffix (excluding evaluation device) : The maximum operating frequency is 16 MHz (at  $T_A = +125\text{ °C}$ ) .
- Devices with A-suffix (excluding evaluation device) : The maximum operating frequency is 24 MHz (at  $T_A = +125\text{ °C}$ ) .

- **Flash security function**

- Protects the content of Flash memory (MB90F352x and MB90F357x only)

- **External bus interface**

- 4 Mbytes external memory space

\* : I<sup>2</sup>C license :

Purchase of Fujitsu I<sup>2</sup>C components conveys a license under the Philips I<sup>2</sup>C Patent Rights to use, these components in an I<sup>2</sup>C system provided that the system conforms to the I<sup>2</sup>C Standard Specification as defined by Philips.

# MB90350 Series

## ■ PRODUCT LINEUP 1

Part Number	MB90F351, MB90F352	MB90F351S, MB90F352S	MB90F351A, MB90F352A	MB90F351TA, MB90F352TA	MB90F351AS, MB90F352AS	MB90F351TAS, MB90F352TAS
CPU	F <sup>2</sup> MC-16LX CPU					
System clock	On-chip PLL clock multiplier (×1, ×2, ×3, ×4, ×6, 1/2 when PLL stops) Minimum instruction execution time : 42 ns (oscillation clock 4 MHz, PLL × 6)					
ROM	Flash memory 64Kbytes : MB90F351(S) 128Kbytes : MB90F352(S)		Dual operation flash memory 64Kbytes : MB90F351A(S), MB90F351TA(S) 128Kbytes : MB90F352A(S), MB90F352TA(S)			
RAM	4 Kbytes					
Emulator-specific power supply*1	—					
Sub clock pin (X0A, X1A) (Max 100 kHz)	Yes	No	Yes		No	
Clock monitor function	No					
Low voltage/CPU operation detection reset	No		No	Yes	No	Yes
Operating voltage range	3.5 V to 5.5 V : at normal operating (not using A/D converter) 4.0 V to 5.5 V : at using A/D converter/Flash programming 4.5 V to 5.5 V : at using external bus					
Operating temperature range	−40 °C to +105 °C (+125 °C up to 16 MHz machine clock)			−40 °C to +125 °C		
Package	LQFP-64					
UART	2 channels					
	Wide range of baud rate settings using a dedicated reload timer Special synchronous options for adapting to different synchronous serial protocols LIN functionality working either as master or slave LIN device					
I <sup>2</sup> C (400 Kbps)	1 channel					
A/D Converter	15 channels					
	10-bit or 8-bit resolution Conversion time : Min 3 μs includes sample time (per one channel)					
16-bit Reload Timer (4 channels)	Operation clock frequency : $f_{sys}/2^1$ , $f_{sys}/2^3$ , $f_{sys}/2^5$ ( $f_{sys}$ = Machine clock frequency) Supports External Event Count function.					
16-bit I/O Timer (2 channels)	I/O Timer 0 (clock input FRCK0) corresponds to ICU 0/1. I/O Timer 1 (clock input FRCK1) corresponds to ICU 4/5/6/7, OCU 4/5/6/7.					
	Signals an interrupt when overflowing. Supports Timer Clear when a match with Output Compare (Channel 0, 4) . Operation clock frequency : $f_{sys}$ , $f_{sys}/2^1$ , $f_{sys}/2^2$ , $f_{sys}/2^3$ , $f_{sys}/2^4$ , $f_{sys}/2^5$ , $f_{sys}/2^6$ , $f_{sys}/2^7$ ( $f_{sys}$ = Machine clock frequency)					
16-bit Output Compare	4 channels					
	Signals an interrupt when 16-bit I/O Timer matches with output compare registers. A pair of compare registers can be used to generate an output signal.					

(Continued)

# MB90350 Series

(Continued)

Part Number Parameter	MB90F351, MB90F352	MB90F351S, MB90F352S	MB90F351A, MB90F352A	MB90F351TA, MB90F352TA	MB90F351AS, MB90F352AS	MB90F351TAS, MB90F352TAS
16-bit Input Capture	6 channels					
	Retains freerun timer value by (rising edge, falling edge or rising & falling edge), signals an interrupt.					
8/16-bit Programmable Pulse Generator	6 channels (16-bit)/10 channels (8-bit) 8-bit reload counters × 12 8-bit reload registers for L pulse width × 12 8-bit reload registers for H pulse width × 12					
	Supports 8-bit and 16-bit operation modes. A pair of 8-bit reload counters can be configured as one 16-bit reload counter or as 8-bit prescaler + 8-bit reload counter. Operation clock frequency : fsys, fsys/2 <sup>1</sup> , fsys/2 <sup>2</sup> , fsys/2 <sup>3</sup> , fsys/2 <sup>4</sup> or 128 μs@fosc = 4 MHz (fsys = Machine clock frequency, fosc = Oscillation clock frequency)					
CAN Interface	1 channel					
	Conforms to CAN Specification Version 2.0 Part A and B. Automatic re-transmission in case of error Automatic transmission responding to Remote Frame Prioritized 16 message buffers for data and ID Supports multiple messages. Flexible configuration of acceptance filtering : Full bit compare/Full bit mask/Two partial bit masks Supports up to 1 Mbps.					
External Interrupt	8 channels					
	Can be used rising edge, falling edge, starting up by H/L level input, external interrupt, extended intelligent I/O services (EI <sup>2</sup> OS) and DMA.					
D/A converter	—					
I/O Ports	Virtually all external pins can be used as general purpose I/O port. All push-pull outputs Bit-wise settable as input/output or peripheral signal Settable as CMOS schmitt trigger/ automotive inputs TTL input level settable for external bus (only for external bus pin)					
Flash Memory	Supports automatic programming, Embedded Algorithm™*2 Write/Erase/Erase-Suspend/Resume commands A flag indicating completion of the algorithm Number of erase cycles : 10,000 times Data retention time : 10 years Boot block configuration Erase can be performed on each block. Block protection with external programming voltage Flash Security Feature for protecting the content of the Flash (MB90F352x only)					
Corresponding EVA name	MB90V340A-102	MB90V340A-101	MB90V340A-102		MB90V340A-101	

\*1 : It is setting of Jumper switch (TOOL VCC) when Emulator (MB2147-01) is used.  
Please refer to the Emulator hardware manual about details.

\*2 : Embedded Algorithm is a trademark of Advanced Micro Devices Inc.

# MB90350 Series

## ■ PRODUCT LINEUP 2

Part Number	MB90351A, MB90352A	MB90351TA, MB90352TA	MB90351AS, MB90352AS	MB90351TAS, MB90352TAS	MB90V340A- 101	MB90V340A- 102
CPU	F <sup>2</sup> MC-16LX CPU					
System clock	On-chip PLL clock multiplier (×1, ×2, ×3, ×4, ×6, 1/2 when PLL stops) Minimum instruction execution time : 42 ns (oscillation clock 4 MHz, PLL × 6)					
ROM	MASK ROM 64Kbytes : MB90351A(S), MB90351TA(S) 128Kbytes : MB90352A(S), MB90352TA(S)				External	
RAM	4 Kbytes				30 Kbytes	
Emulator-specific power supply*	—				Yes	
Sub clock pin (X0A, X1A) (Max 100 kHz)	Yes		No		No	Yes
Clock monitor function	No					
Low voltage/CPU operation detection reset	No	Yes	No	Yes	No	
Operating voltage range	3.5 V to 5.5 V : at normal operating (not using A/D converter) 4.0 V to 5.5 V : at using A/D converter 4.5 V to 5.5 V : at using external bus				5 V ± 10%	
Operating temperature range	-40 °C to +125 °C				—	
Package	LQFP-64				PGA-299	
UART	2 channels				5 channels	
	Wide range of baud rate settings using a dedicated reload timer Special synchronous options for adapting to different synchronous serial protocols LIN functionality working either as master or slave LIN device					
I <sup>2</sup> C (400 Kbps)	1 channel				2 channels	
A/D Converter	15 channels				24 channels	
	10-bit or 8-bit resolution Conversion time : Min 3 μs includes sample time (per one channel)					
16-bit Reload Timer (4 channels)	Operation clock frequency : $f_{sys}/2^1$ , $f_{sys}/2^3$ , $f_{sys}/2^5$ ( $f_{sys}$ = Machine clock frequency) Supports External Event Count function.					
16-bit I/O Timer (2 channels)	I/O Timer 0 (clock input FRCK0) corresponds to ICU 0/1. I/O Timer 1 (clock input FRCK1) corresponds to ICU 4/5/6/7, OCU 4/5/6/7.				I/O Timer 0 corresponds to ICU 0/1/2/3, OCU 0/1/2/3. I/O Timer 1 corresponds to ICU 4/5/6/7, OCU 4/5/6/7.	
	Signals an interrupt when overflowing. Supports Timer Clear when a match with Output Compare (Channel 0, 4) . Operation clock frequency : $f_{sys}$ , $f_{sys}/2^1$ , $f_{sys}/2^2$ , $f_{sys}/2^3$ , $f_{sys}/2^4$ , $f_{sys}/2^5$ , $f_{sys}/2^6$ , $f_{sys}/2^7$ ( $f_{sys}$ = Machine clock frequency)					

(Continued)

# MB90350 Series

(Continued)

Part Number Parameter	MB90351A, MB90352A	MB90351TA, MB90352TA	MB90351AS, MB90352AS	MB90351TAS, MB90352TAS	MB90V340A- 101	MB90V340A- 102
16-bit Output Compare	4 channels				8 channels	
	Signals an interrupt when 16-bit I/O Timer matches output compare registers. A pair of compare registers can be used to generate an output signal.					
16-bit Input Capture	6 channels				8 channels	
	Retains freerun timer value by (rising edge, falling edge or rising & falling edge), signals an interrupt.					
8/16-bit Programmable Pulse Generator	6 channels (16-bit)/10 channels (8-bit) 8-bit reload counters × 12 8-bit reload registers for L pulse width × 12 8-bit reload registers for H pulse width × 12				8 channels (16-bit)/ 16 channels (8-bit) 8-bit reload counters × 16 8-bit reload registers for L pulse width × 16 8-bit reload registers for H pulse width × 16	
	Supports 8-bit and 16-bit operation modes. A pair of 8-bit reload counters can be configured as one 16-bit reload counter or as 8-bit prescaler + 8-bit reload counter. Operation clock frequency : $f_{sys}$ , $f_{sys}/2^1$ , $f_{sys}/2^2$ , $f_{sys}/2^3$ , $f_{sys}/2^4$ or $128 \mu s @ f_{osc} = 4 \text{ MHz}$ ( $f_{sys}$ = Machine clock frequency, $f_{osc}$ = Oscillation clock frequency)					
CAN Interface	1 channel				3 channels	
	Conforms to CAN Specification Version 2.0 Part A and B. Automatic re-transmission in case of error Automatic transmission responding to Remote Frame Prioritized 16 message buffers for data and ID Supports multiple messages. Flexible configuration of acceptance filtering : Full bit compare/Full bit mask/Two partial bit masks Supports up to 1 Mbps.					
External Interrupt	8 channels				16 channels	
	Can be used rising edge, falling edge, starting up by H/L level input, external interrupt, extended intelligent I/O services (EI <sup>2</sup> OS) and DMA.					
D/A converter	—				2 channels	
I/O Ports	Virtually all external pins can be used as general purpose I/O port. All push-pull outputs Bit-wise settable as input/output or peripheral signal Settable as CMOS schmitt trigger/ automotive inputs TTL input level settable for external bus (only for external bus pin)					
Flash Memory	—					
Corresponding EVA name	MB90V340A-102		MB90V340A-101		—	

\* : It is setting of Jumper switch (TOOL VCC) when Emulator (MB2147-01) is used.  
Please refer to the Emulator hardware manual about details.

# MB90350 Series

## ■ PRODUCT LINEUP 3

Part Number Parameter	MB90F356A, MB90F357A	MB90F356TA, MB90F357TA	MB90F356AS, MB90F357AS	MB90F356TAS, MB90F357TAS
CPU	F <sup>2</sup> MC-16LX CPU			
System clock	On-chip PLL clock multiplier (×1, ×2, ×3, ×4, ×6, 1/2 when PLL stops) Minimum instruction execution time : 42 ns (oscillation clock 4 MHz, PLL × 6)			
ROM	Dual operation flash memory 64Kbytes : MB90F356A(S), MB90F356TA(S) 128Kbytes : MB90F357A(S), MB90F357TA(S)			
RAM	4 Kbytes			
Emulator-specific power supply*1	—			
Sub clock pin (X0A, X1A)	Yes		No (internal CR oscillation can be used as sub clock)	
Clock monitor function	Yes			
Low voltage/CPU operation detection reset	No	Yes	No	Yes
Operating voltage range	3.5 V to 5.5 V : at normal operating (not using A/D converter) 3.5 V to 5.5 V : at using A/D converter/Flash programming 3.5 V to 5.5 V : at using external bus			
Operating temperature range	-40 °C to +125 °C			
Package	LQFP-64			
UART	2 channels			
	Wide range of baud rate settings using a dedicated reload timer Special synchronous options for adapting to different synchronous serial protocols LIN functionality working either as master or slave LIN device			
I <sup>2</sup> C (400 Kbps)	1 channel			
A/D Converter	15 channels			
	10-bit or 8-bit resolution Conversion time : Min 3 μs includes sample time (per one channel)			
16-bit Reload Timer (4 channels)	Operation clock frequency : $f_{sys}/2^1$ , $f_{sys}/2^3$ , $f_{sys}/2^5$ ( $f_{sys}$ = Machine clock frequency) Supports External Event Count function.			
16-bit I/O Timer (2 channels)	I/O Timer 0 (clock input FRCK0) corresponds to ICU 0/1. I/O Timer 1 (clock input FRCK1) corresponds to ICU 4/5/6/7, OCU 4/5/6/7.			
	Signals an interrupt when overflowing. Supports Timer Clear when a match with Output Compare (Channel 0, 4) . Operation clock frequency : $f_{sys}$ , $f_{sys}/2^1$ , $f_{sys}/2^2$ , $f_{sys}/2^3$ , $f_{sys}/2^4$ , $f_{sys}/2^5$ , $f_{sys}/2^6$ , $f_{sys}/2^7$ ( $f_{sys}$ = Machine clock frequency)			
16-bit Output Compare	4 channels			
	Signals an interrupt when 16-bit I/O Timer matches with output compare registers. A pair of compare registers can be used to generate an output signal.			

(Continued)

# MB90350 Series

(Continued)

Part Number Parameter	MB90F356A, MB90F357A	MB90F356TA, MB90F357TA	MB90F356AS, MB90F357AS	MB90F356TAS, MB90F357TAS
16-bit Input Capture	6 channels			
	Retains freerun timer value by (rising edge, falling edge or rising & falling edge), signals an interrupt.			
8/16-bit Programmable Pulse Generator	6 channels (16-bit)/10 channels (8-bit) 8-bit reload counters × 12 8-bit reload registers for L pulse width × 12 8-bit reload registers for H pulse width × 12			
	Supports 8-bit and 16-bit operation modes. A pair of 8-bit reload counters can be configured as one 16-bit reload counter or as 8-bit prescaler + 8-bit reload counter. Operation clock frequency : fsys, fsys/2 <sup>1</sup> , fsys/2 <sup>2</sup> , fsys/2 <sup>3</sup> , fsys/2 <sup>4</sup> or 128 μs@fosc = 4 MHz (fsys = Machine clock frequency, fosc = Oscillation clock frequency)			
CAN Interface	1 channel			
	Conforms to CAN Specification Version 2.0 Part A and B. Automatic re-transmission in case of error Automatic transmission responding to Remote Frame Prioritized 16 message buffers for data and ID Supports multiple messages. Flexible configuration of acceptance filtering : Full bit compare/Full bit mask/Two partial bit masks Supports up to 1 Mbps.			
External Interrupt	8 channels			
	Can be used rising edge, falling edge, starting up by H/L level input, external interrupt, extended intelligent I/O services (EI <sup>2</sup> OS) and DMA.			
D/A converter	—			
I/O Ports	Virtually all external pins can be used as general purpose I/O port. All push-pull outputs Bit-wise settable as input/output or peripheral module signal Settable as CMOS schmitt trigger/ automotive inputs TTL input level settable for external bus (only for external bus pin)			
Flash Memory	Supports automatic programming, Embedded Algorithm <sup>TM*2</sup> Write/Erase/Erased-Suspend/Resume commands A flag indicating completion of the algorithm Number of erase cycles : 10,000 times Data retention time : 10 years Boot block configuration Erase can be performed on each block. Block protection with external programming voltage Flash Security Feature for protecting the content of the Flash (MB90F357x only)			
Corresponding EVA name	MB90V340A-104		MB90V340A-103	

\*1 : It is setting of Jumper switch (TOOL VCC) when Emulator (MB2147-01) is used.  
Please refer to the Emulator hardware manual about details.

\*2 : Embedded Algorithm is a trademark of Advanced Micro Devices Inc.

# MB90350 Series

## ■ PRODUCT LINEUP 4

Part Number	MB90356A, MB90357A	MB90356TA, MB90357TA	MB90356AS, MB90357AS	MB90356TAS, MB90357TAS	MB90V340A- 103	MB90V340A- 104
CPU	F <sup>2</sup> MC-16LX CPU					
System clock	On-chip PLL clock multiplier (×1, ×2, ×3, ×4, ×6, 1/2 when PLL stops) Minimum instruction execution time : 42 ns (oscillation clock 4 MHz, PLL × 6)					
ROM	MASK ROM 64Kbytes : MB90356A(S), MB90356TA(S) 128Kbytes : MB90357A(S), MB90357TA(S)				External	
RAM	4 Kbytes				30 Kbytes	
Emulator-specific power supply*	—				Yes	
Sub clock pin (X0A, X1A)	Yes		No (internal CR oscillation can be used as sub clock)		No (internal CR oscillation can be used as sub clock)	Yes
Clock monitor function	Yes					
Low voltage/CPU operation detection reset	No	Yes	No	Yes	No	
Operating voltage range	3.5 V to 5.5 V : at normal operating (not using A/D converter) 4.0 V to 5.5 V : at using A/D converter 4.5 V to 5.5 V : at using external bus				5 V ± 10%	
Operating temperature range	-40 °C to +125 °C				—	
Package	LQFP-64				PGA-299	
UART	2 channels				5 channels	
	Wide range of baud rate settings using a dedicated reload timer Special synchronous options for adapting to different synchronous serial protocols LIN functionality working either as master or slave LIN device					
I <sup>2</sup> C (400 Kbps)	1 channel				2 channels	
A/D Converter	15 channels				24 channels	
	10-bit or 8-bit resolution Conversion time : Min 3 μs includes sample time (per one channel)					
16-bit Reload Timer (4 channels)	Operation clock frequency : $f_{sys}/2^1$ , $f_{sys}/2^3$ , $f_{sys}/2^5$ ( $f_{sys}$ = Machine clock frequency) Supports External Event Count function.					
16-bit I/O Timer (2 channels)	I/O Timer 0 (clock input FRCK0) corresponds to ICU 0/1. I/O Timer 1 (clock input FRCK1) corresponds to ICU 4/5/6/7, OCU 4/5/6/7.				I/O Timer 0 corresponds to ICU 0/1/2/3, OCU 0/1/2/3. I/O Timer 1 corresponds to ICU 4/5/6/7, OCU 4/5/6/7.	
	Signals an interrupt when overflowing. Supports Timer Clear when a match with Output Compare (Channel 0, 4) . Operation clock frequency : $f_{sys}$ , $f_{sys}/2^1$ , $f_{sys}/2^2$ , $f_{sys}/2^3$ , $f_{sys}/2^4$ , $f_{sys}/2^5$ , $f_{sys}/2^6$ , $f_{sys}/2^7$ ( $f_{sys}$ = Machine clock frequency)					

(Continued)

# MB90350 Series

(Continued)

Part Number Parameter	MB90356A, MB90357A	MB90356TA, MB90357TA	MB90356AS, MB90357AS	MB90356TAS, MB90357TAS	MB90V340A- 103	MB90V340A- 104
16-bit Output Compare	4 channels				8 channels	
	Signals an interrupt when 16-bit I/O Timer matches with output compare registers. A pair of compare registers can be used to generate an output signal.					
16-bit Input Capture	6 channels				8 channels	
	Retains freerun timer value by (rising edge, falling edge or rising & falling edge), signals an interrupt.					
8/16-bit Programmable Pulse Generator	6 channels (16-bit)/10 channels (8-bit) 8-bit reload counters × 12 8-bit reload registers for L pulse width × 12 8-bit reload registers for H pulse width × 12				8 channels (16-bit)/16 channels (8-bit) 8-bit reload counters × 16 8-bit reload registers for L pulse width × 16 8-bit reload registers for H pulse width × 16	
	Supports 8-bit and 16-bit operation modes. A pair of 8-bit reload counters can be configured as one 16-bit reload counter or as 8-bit prescaler + 8-bit reload counter. Operation clock frequency : $f_{sys}$ , $f_{sys}/2^1$ , $f_{sys}/2^2$ , $f_{sys}/2^3$ , $f_{sys}/2^4$ or $128 \mu s @ f_{osc} = 4 \text{ MHz}$ ( $f_{sys}$ = Machine clock frequency, $f_{osc}$ = Oscillation clock frequency)					
CAN Interface	1 channel				3 channels	
	Conforms to CAN Specification Version 2.0 Part A and B. Automatic re-transmission in case of error Automatic transmission responding to Remote Frame Prioritized 16 message buffers for data and ID Supports multiple messages. Flexible configuration of acceptance filtering : Full bit compare/Full bit mask/Two partial bit masks Supports up to 1 Mbps.					
External Interrupt	8 channels				16 channels	
	Can be used rising edge, falling edge, starting up by H/L level input, external interrupt, extended intelligent I/O services (EI <sup>2</sup> OS) and DMA.					
D/A converter	—				2 channels	
I/O Ports	Virtually all external pins can be used as general purpose I/O port. All push-pull outputs Bit-wise settable as input/output or peripheral module signal Settable as CMOS schmitt trigger/ automotive inputs TTL input level settable for external bus (only for external bus pin)					
Flash Memory	—					
Corresponding EVA name	MB90V340A-104		MB90V340A-103		—	

\* : It is setting of Jumper switch (TOOL VCC) when Emulator (MB2147-01) is used.  
Please refer to the Emulator hardware manual about details.

## ■ PACKAGES AND PRODUCT CORRESPONDENCE

Package	MB90V340A -101 -102 -103 -104	MB90F351 MB90F351S MB90F352 MB90F352S	MB90F351A (S) , MB90F351TA (S) MB90F352A (S) , MB90F352TA (S) MB90F356A (S) , MB90F356TA (S) MB90F357A (S) , MB90F357TA (S) MB90351A (S) , MB90351TA (S) MB90352A (S) , MB90352TA (S) MB90356A (S) , MB90356TA (S) MB90357A (S) , MB90357TA (S)
PGA-299C-A01	○	×	×
FPT-64P-M09 (12 mm □ , 0.65 mm pitch)	×	○	×
FPT-64P-M23 (12 mm □ , 0.65 mm pitch)	×	×	○
FPT-64P-M24 (10 mm □ , 0.50 mm pitch)	×	×	○*

\* : This device is under development.

○ : Yes, × : No

Note : Refer to “■ PACKAGE DIMENSIONS” for detail of each package.

# MB90350 Series

## PIN ASSIGNMENTS

- MB90F351(S), MB90F352(S), MB90F351A(S), MB90F351TA(S), MB90F352A(S), MB90F352TA(S), MB90F356A(S), MB90F356TA(S), MB90F357A(S), MB90F357TA(S), MB90351A(S), MB90351TA(S), MB90352A(S), MB90352TA(S), MB90356A(S), MB90356TA(S), MB90357A(S), MB90357TA(S),

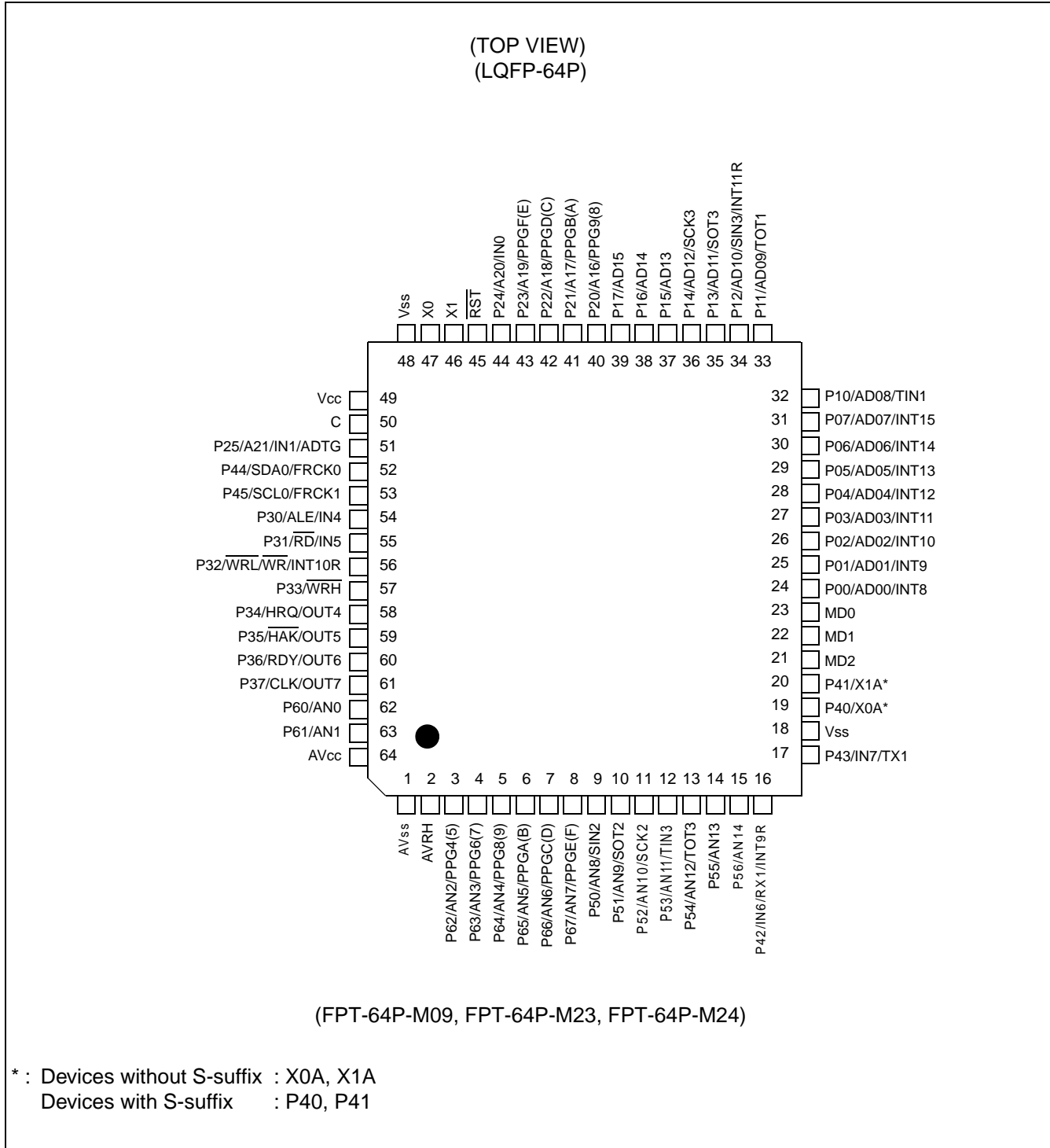

## ■ PIN DESCRIPTION

Pin No.	Pin name	Circuit type	Function
LQFP64*			
46	X1	A	Oscillation output pin
47	X0		Oscillation input pin
45	$\overline{\text{RST}}$	E	Reset input pin
3 to 8	P62 to P67	I	General purpose I/O ports
	AN2 to AN7		Analog input pins for A/D converter
	PPG4 (5), 6 (7), 8 (9), A (B), C (D), E (F)		Output pins for PPGs
9	P50	O	General purpose I/O port
	AN8		Analog input pin for A/D converter
	SIN2		Serial data input pin for UART2
10	P51	I	General purpose I/O port
	AN9		Analog input pin for A/D converter
	SOT2		Serial data output pin for UART2
11	P52	I	General purpose I/O port
	AN10		Analog input pin for A/D converter
	SCK2		Serial clock I/O pin for UART2
12	P53	I	General purpose I/O port
	AN11		Analog input pin for A/D converter
	TIN3		Event input pin for reload timer3
13	P54	I	General purpose I/O port
	AN12		Analog input pin for A/D converter
	TOT3		Output pin for reload timer3
14, 15	P55, P56	I	General purpose I/O ports
	AN13, AN14		Analog input pins for A/D converter
16	P42	F	General purpose I/O port
	IN6		Data sample input pin for input capture ICU6
	RX1		RX input pin for CAN1
	INT9R		External interrupt request input pin for INT9
17	P43	F	General purpose I/O port
	IN7		Data sample input pin for input capture ICU7
	TX1		TX output pin for CAN1
19, 20	P40, P41	F	General purpose I/O ports (devices with S-suffix and MB90V340A-101/103)
	X0A, X1A	B	X0A : Oscillation input pins for sub clock X1A : Oscillation output pins for sub clock (devices without S-suffix and MB90V340A-102/104)

(Continued)

# MB90350 Series

Pin No. LQFP64*	Pin name	Circuit type	Function
24 to 31	P00 to P07	G	General purpose I/O ports. The register can be set to select whether to use a pull-up resistor. This function is enabled in single-chip mode.
	AD00 to AD07		Input/output pins of external address data bus lower 8 bits. This function is enabled when the external bus is enabled.
	INT8 to INT15		External interrupt request input pins for INT8 to INT15
32	P10	G	General purpose I/O port. The register can be set to select whether to use a pull-up resistor. This function is enabled in single-chip mode.
	AD08		Input/output pin for external bus address data bus bit 8. This function is enabled when external bus is enabled.
	TIN1		Event input pin for reload timer1
33	P11	G	General purpose I/O port. The register can be set to select whether to use a pull-up resistor. This function is enabled in single-chip mode.
	AD09		Input/output pin for external bus address data bus bit 9. This function is enabled when external bus is enabled.
	TOT1		Output pin for reload timer1
34	P12	N	General purpose I/O port. The register can be set to select whether to use a pull-up resistor. This function is enabled in single-chip mode.
	AD10		Input/output pin for external bus address data bus bit 10. This function is enabled when external bus is enabled.
	SIN3		Serial data input pin for UART3
	INT11R		External interrupt request input pin for INT11
35	P13	G	General purpose I/O port. The register can be set to select whether to use a pull-up resistor. This function is enabled in single-chip mode.
	AD11		Input/output pin for external bus address data bus bit 11. This function is enabled when external bus is enabled.
	SOT3		Serial data output pin for UART3
36	P14	G	General purpose I/O port. The register can be set to select whether to use a pull-up resistor. This function is enabled in single-chip mode.
	AD12		Input/output pin for external bus address data bus bit 12. This function is enabled when external bus is enabled.
	SCK3		Clock input/output pin for UART3
37	P15	N	General purpose I/O port. The register can be set to select whether to use a pull-up resistor. This function is enabled in single-chip mode.
	AD13		Input/output pin for external bus address data bus bit 13. This function is enabled when external bus is enabled.
38	P16	G	General purpose I/O port. The register can be set to select whether to use a pull-up resistor. This function is enabled in single-chip mode.
	AD14		Input/output pin for external bus address data bus bit 14. This function is enabled when external bus is enabled.

(Continued)

# MB90350 Series

Pin No.	Pin name	Circuit type	Function
LQFP64*			
39	P17	G	General purpose I/O port. The register can be set to select whether to use a pull-up resistor. This function is enabled in single-chip mode.
	AD15		Input/output pin for external bus address data bus bit 15. This function is enabled when external bus is enabled.
40 to 43	P20 to P23	G	General purpose I/O ports. The register can be set to select whether to use a pull-up resistor. In external bus mode, the pins are enabled as a general-purpose I/O port when the corresponding bit in the external address output control register (HACR) is 1.
	A16 to A19		Output pins for A16 to A19 of the external address data bus. When the corresponding bit in the external address output control register (HACR) is 0, the pins are enabled as high address output pins A16 to A19.
	PPG9 (8) , PPGB (A) , PPGD (C) , PPGF (E)		Output pins for PPGs
44	P24	G	General purpose I/O port. The register can be set to select whether to use a pull-up resistor. In external bus mode, the pin is enabled as a general-purpose I/O port when the corresponding bit in the external address output control register (HACR) is 1.
	A20		Output pin for A20 of the external address data bus. When the corresponding bit in the external address output control register (HACR) is 0, the pin is enabled as high address output pin A20.
	IN0		Data sample input pin for input capture ICU0
51	P25	G	General purpose I/O port. The register can be set to select whether to use a pull-up resistor. In external bus mode, the pin is enabled as a general-purpose I/O port when the corresponding bit in the external address output control register (HACR) is 1.
	A21		Output pin for A21 of the external address data bus. When the corresponding bit in the external address output control register (HACR) is 0, the pin is enabled as high address output pin A21.
	IN1		Data sample input pin for input capture ICU1
	ADTG		Trigger input pin for A/D converter
52	P44	H	General purpose I/O port
	SDA0		Serial data I/O pin for I <sup>2</sup> C 0
	FRCK0		Input pin for the 16-bit I/O Timer 0
53	P45	H	General purpose I/O port
	SCL0		Serial clock I/O pin for I <sup>2</sup> C 0
	FRCK1		Input pin for the 16-bit I/O Timer 1

(Continued)

# MB90350 Series

Pin No. LQFP64*	Pin name	Circuit type	Function
54	P30	G	General purpose I/O port. The register can be set to select whether to use a pull-up resistor. This function is enabled in single-chip mode.
	ALE		Address latch enable output pin. This function is enabled when external bus is enabled.
	IN4		Data sample input pin for input capture ICU4
55	P31	G	General purpose I/O port. The register can be set to select whether to use a pull-up resistor. This function is enabled in single-chip mode.
	$\overline{RD}$		Read strobe output pin for data bus. This function is enabled when external bus is enabled.
	IN5		Data sample input pin for input capture ICU5
56	P32	G	General purpose I/O port. The register can be set to select whether to use a pull-up resistor. This function is enabled either in single-chip mode or with the $\overline{WR/WRL}$ pin output disabled.
	$\overline{WR/WRL}$		Write strobe output pin for the data bus. This function is enabled when both the external bus and the $\overline{WR/WRL}$ pin output are enabled. $\overline{WRL}$ is used to write-strobe 8 lower bits of the data bus in 16-bit access. $\overline{WR}$ is used to write-strobe 8 bits of the data bus in 8-bit access.
	INT10R		External interrupt request input pin for INT10
57	P33	G	General purpose I/O port. The register can be set to select whether to use a pull-up resistor. This function is enabled either in single-chip mode, in external bus 8-bit mode or with the $\overline{WRH}$ pin output disabled.
	$\overline{WRH}$		Write strobe output pin for the 8 higher bits of the data bus. This function is enabled when the external bus is enabled, when the external bus 16-bit mode is selected, and when the $\overline{WRH}$ output pin is enabled.
58	P34	G	General purpose I/O port. The register can be set to select whether to use a pull-up resistor. This function is enabled either in single-chip mode or with the hold function disabled.
	HRQ		Hold request input pin. This function is enabled when both the external bus and the hold function are enabled.
	OUT4		Waveform output pin for output compare OCU4
59	P35	G	General purpose I/O port. The register can be set to select whether to use a pull-up resistor. This function is enabled either in single-chip mode or with the hold function disabled.
	$\overline{HAK}$		Hold acknowledge output pin. This function is enabled when both the external bus and the hold function are enabled.
	OUT5		Waveform output pin for output compare OCU5
60	P36	G	General purpose I/O port. The register can be set to select whether to use a pull-up resistor. This function is enabled either in single-chip mode or with the external ready function disabled.
	RDY		Ready input pin. This function is enabled when both the external bus and the external ready function are enabled.
	OUT6		Waveform output pin for output compare OCU6

(Continued)

(Continued)

Pin No. LQFP64*	Pin name	Circuit type	Function
61	P37	G	General purpose I/O port. The register can be set to select whether to use a pull-up resistor. This function is enabled either in single-chip mode or with the CLK output disabled.
	CLK		CLK output pin. This function is enabled when both the external bus and CLK output are enabled.
	OUT7		Waveform output pin for output compare OCU7
62, 63	P60, P61	I	General purpose I/O ports
	AN0, AN1		Analog input pins for A/D converter
64	AV <sub>cc</sub>	K	V <sub>cc</sub> power input pin for analog circuits
2	AVRH	L	Reference voltage input for the A/D converter. This power supply must be turned on or off while a voltage higher than or equal to AVRH is applied to AV <sub>cc</sub> .
1	AV <sub>ss</sub>	K	V <sub>ss</sub> power input pin for analog circuits
22, 23	MD1, MD0	C	Input pins for specifying the operating mode
21	MD2	D	Input pin for specifying the operating mode
49	V <sub>cc</sub>	—	Power (3.5 V to 5.5 V) input pin
18, 48	V <sub>ss</sub>	—	Power (0 V) input pins
50	C	K	This is the power supply stabilization capacitor pin. It should be connected to a higher than or equal to 0.1 μF ceramic capacitor.

\* : FPT-64P-M09, FPT-64P-M23, FPT-64P-M24

# MB90350 Series

## ■ I/O CIRCUIT TYPE

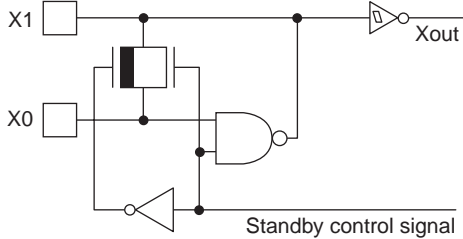
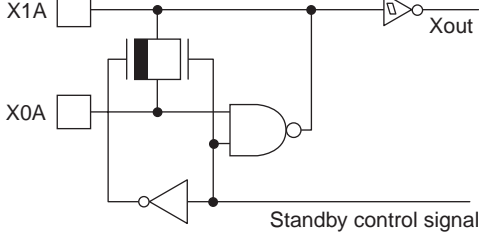
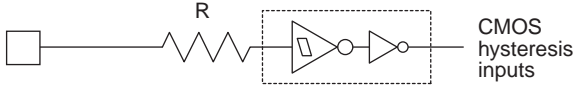
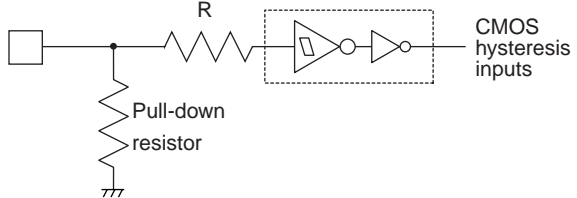
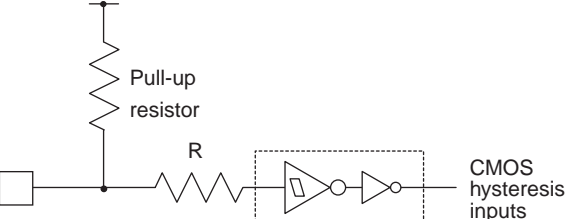
Type	Circuit	Remarks
A		<p>Oscillation circuit</p> <ul style="list-style-type: none"> <li>• High-speed oscillation feedback resistor = approx. 1 MΩ</li> </ul>
B		<p>Oscillation circuit</p> <ul style="list-style-type: none"> <li>• Low-speed oscillation feedback resistor = approx. 10 MΩ</li> </ul>
C		<p>Mask ROM device:</p> <ul style="list-style-type: none"> <li>• CMOS hysteresis input pin</li> </ul> <p>Flash memory device:</p> <ul style="list-style-type: none"> <li>• CMOS input pin</li> </ul>
D		<p>Mask ROM device:</p> <ul style="list-style-type: none"> <li>• CMOS hysteresis input pin</li> <li>• Pull-down resistor value: approx. 50 kΩ</li> </ul> <p>Flash memory device:</p> <ul style="list-style-type: none"> <li>• CMOS input pin</li> <li>• No Pull-down</li> </ul>
E		<p>CMOS hysteresis input pin</p> <ul style="list-style-type: none"> <li>• Pull-up resistor value: approx. 50 kΩ</li> </ul>

(Continued)

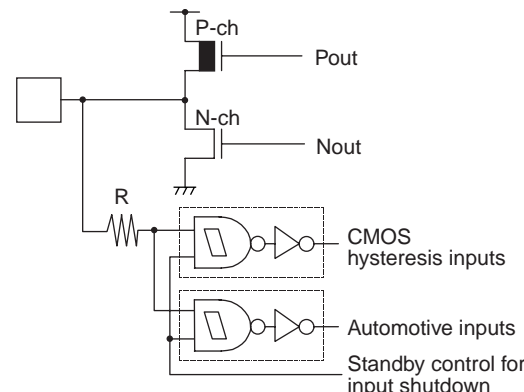
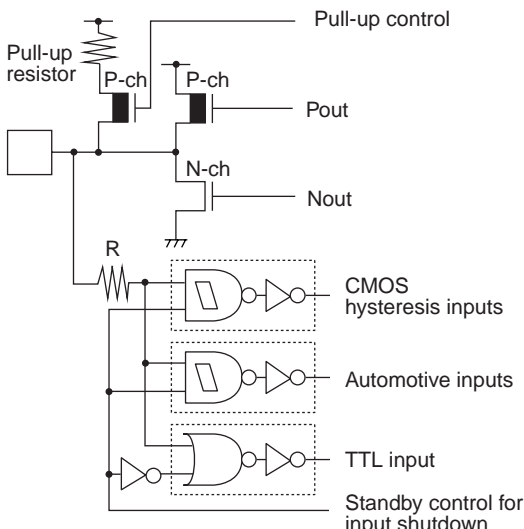
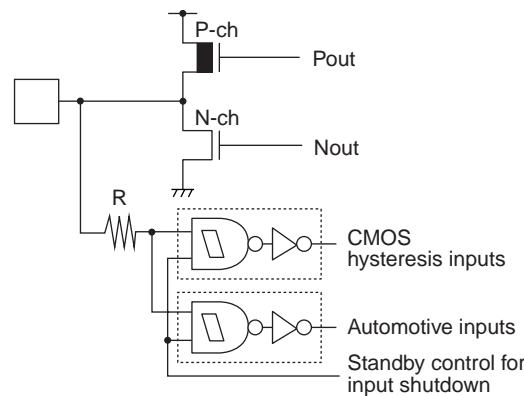
Type	Circuit	Remarks
F		<ul style="list-style-type: none"> <li>• CMOS level output (<math>I_{OL} = 4 \text{ mA}</math>, <math>I_{OH} = -4 \text{ mA}</math>)</li> <li>• CMOS hysteresis inputs (With the standby-time input shutdown function)</li> <li>• Automotive input (With the standby-time input shutdown function)</li> </ul>
G		<ul style="list-style-type: none"> <li>• CMOS level output (<math>I_{OL} = 4 \text{ mA}</math>, <math>I_{OH} = -4 \text{ mA}</math>)</li> <li>• CMOS hysteresis inputs (With the standby-time input shutdown function)</li> <li>• Automotive input (With the standby-time input shutdown function)</li> <li>• TTL input (With the standby-time input shutdown function)</li> <li>• Programmable pull-up resistor: approx. <math>50 \text{ k}\Omega</math></li> </ul>
H		<ul style="list-style-type: none"> <li>• CMOS level output (<math>I_{OL} = 3 \text{ mA}</math>, <math>I_{OH} = -3 \text{ mA}</math>)</li> <li>• CMOS hysteresis inputs (With the standby-time input shutdown function)</li> <li>• Automotive input (With the standby-time input shutdown function)</li> </ul>

(Continued)

# MB90350 Series

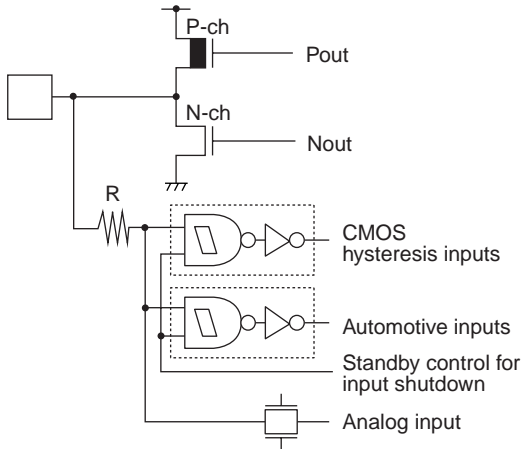
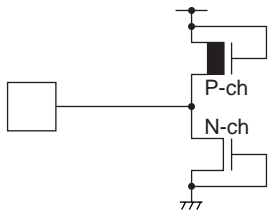
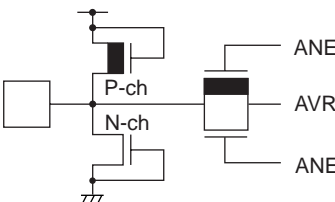
Type	Circuit	Remarks
I	 <p>The diagram shows a CMOS output stage with a P-channel MOSFET (P-ch) and an N-channel MOSFET (N-ch). The P-ch MOSFET is connected to the output terminal Pout, and the N-ch MOSFET is connected to the output terminal Nout. A resistor R is connected between the input and the gates of both MOSFETs. The input is also connected to several other input types: CMOS hysteresis inputs, Automotive inputs, Standby control for input shutdown, and an Analog input.</p>	<ul style="list-style-type: none"> <li>• CMOS level output (<math>I_{OL} = 4 \text{ mA}</math>, <math>I_{OH} = -4 \text{ mA}</math>)</li> <li>• CMOS hysteresis inputs (With the standby-time input shutdown function)</li> <li>• Automotive input (With the standby-time input shutdown function)</li> <li>• A/D analog input</li> </ul>
K	 <p>The diagram shows a power supply input protection circuit. It consists of a P-channel MOSFET (P-ch) and an N-channel MOSFET (N-ch). The P-ch MOSFET is connected to the power supply input, and the N-ch MOSFET is connected to ground. The gates of both MOSFETs are connected to the input line.</p>	<ul style="list-style-type: none"> <li>• Power supply input protection circuit</li> </ul>
L	 <p>The diagram shows an A/D converter reference voltage power supply input pin with a protection circuit. It consists of a P-channel MOSFET (P-ch) and an N-channel MOSFET (N-ch). The P-ch MOSFET is connected to the power supply input, and the N-ch MOSFET is connected to ground. The gates of both MOSFETs are connected to the input line. The output of the protection circuit is connected to pins ANE, AVR, and ANE.</p>	<ul style="list-style-type: none"> <li>• A/D converter reference voltage power supply input pin, with the protection circuit</li> <li>• Flash memory devices do not have a protection circuit against <math>V_{CC}</math> for pin AVRH.</li> </ul>

(Continued)

(Continued)

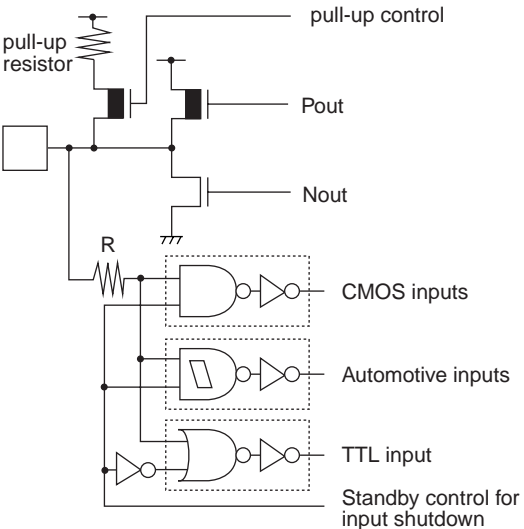
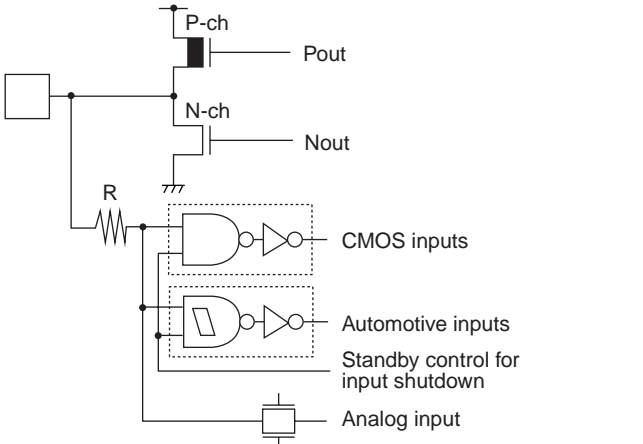
Type	Circuit	Remarks
N	 <p>The diagram for Type N shows a pull-up resistor connected to the input line. A pull-up control signal is connected to the gate of a P-channel MOSFET (P-ch) and the gate of an N-channel MOSFET (N-ch). The P-ch MOSFET's source is connected to the input line, and its drain is connected to the output node. The N-ch MOSFET's source is connected to ground, and its drain is also connected to the output node. The output node is labeled Pout. The input line is also connected to a resistor R, which is connected to ground. This resistor R is connected to the inputs of three different input types: CMOS inputs, Automotive inputs, and TTL input. A standby control circuit, consisting of a NAND gate and an inverter, is connected to the input line and the standby control for input shutdown signal.</p>	<ul style="list-style-type: none"> <li>• CMOS level output (<math>I_{OL} = 4 \text{ mA}</math>, <math>I_{OH} = -4 \text{ mA}</math>)</li> <li>• CMOS inputs (With the standby-time input shutdown function)</li> <li>• Automotive input (With the standby-time input shutdown function)</li> <li>• TTL input (With the standby-time input shutdown function)</li> <li>• Programmable pull-up resistor: approx. <math>50 \text{ k}\Omega</math></li> </ul>
O	 <p>The diagram for Type O shows a pull-up resistor connected to the input line. A P-channel MOSFET (P-ch) and an N-channel MOSFET (N-ch) are connected to the output node. The P-ch MOSFET's source is connected to the input line, and its drain is connected to the output node. The N-ch MOSFET's source is connected to ground, and its drain is also connected to the output node. The output node is labeled Pout. The input line is also connected to a resistor R, which is connected to ground. This resistor R is connected to the inputs of three different input types: CMOS inputs, Automotive inputs, and Standby control for input shutdown. An analog input is also connected to the input line.</p>	<ul style="list-style-type: none"> <li>• CMOS level output (<math>I_{OL} = 4 \text{ mA}</math>, <math>I_{OH} = -4 \text{ mA}</math>)</li> <li>• CMOS inputs (With the standby-time input shutdown function)</li> <li>• Automotive input (With the standby-time input shutdown function)</li> <li>• A/D analog input</li> </ul>

# MB90350 Series

## ■ HANDLING DEVICES

Special care is required for the following when handling the device :

- Preventing latch-up
- Treatment of unused pins
- Using external clock
- Precautions for when not using a sub clock signal
- Notes on during operation of PLL clock mode
- Power supply pins ( $V_{CC}/V_{SS}$ )
- Pull-up/down resistors
- Crystal Oscillator Circuit
- Turning-on Sequence of Power Supply to A/D Converter and Analog Inputs
- Connection of Unused Pins of A/D Converter
- Notes on Energization
- Stabilization of power supply voltage
- Initialization
- Port0 to port3 output during Power-on (External-bus mode)
- Notes on using CAN Function
- Flash security Function
- Correspondence with  $T_A = +105\text{ }^\circ\text{C}$  or more
- Low voltage/CPU operation detection reset circuit
- Internal CR oscillation circuit

### 1. Preventing latch-up

CMOS IC chips may suffer latch-up under the following conditions :

- A voltage higher than  $V_{CC}$  or lower than  $V_{SS}$  is applied to an input or output pin.
- A voltage higher than the rated voltage is applied between  $V_{CC}$  pin and  $V_{SS}$  pin.
- The  $AV_{CC}$  power supply is applied before the  $V_{CC}$  voltage.

Latch-up may increase the power supply current drastically, causing thermal damage to the device.

In using the devices, take sufficient care to avoid exceeding maximum ratings.

For the same reason, also be careful not to let the analog power-supply voltage ( $AV_{CC}$ ,  $AV_{RH}$ ) exceed the digital power-supply voltage.

### 2. Handling unused pins

Leaving unused input pins open may result in misbehavior or latch up and possible permanent damage of the device. Therefore they must be pulled up or pulled down through resistors. In this case those resistors should be more than  $2\text{ k}\Omega$  .

Unused I/O pins should be set to the output state and can be left open, or the input state with the above described connection.

### 3. Using external clock

To use external clock, drive the X0 pin and leave X1 pin open.

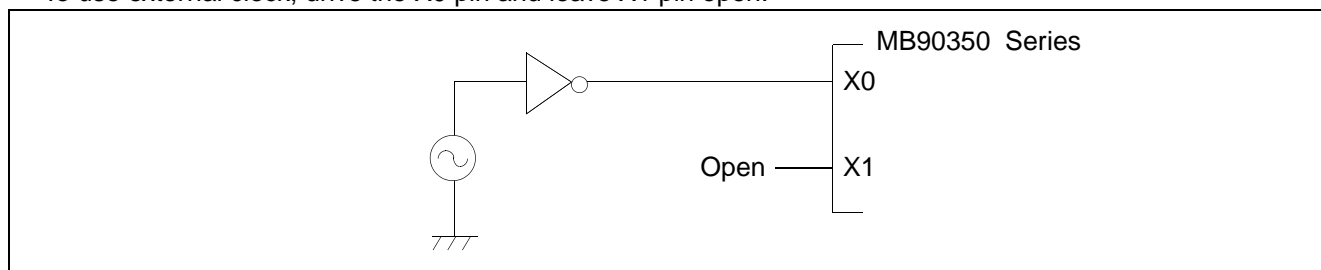

## 4. Precautions for when not using a sub clock signal

If you do not connect pins X0A and X1A to an oscillator, use pull-down handling on the X0A pin, and leave the X1A pin open.

## 5. Notes on during operation of PLL clock mode

If the PLL clock mode is selected, the microcontroller attempts to be working with the self-oscillating circuit even when there is no external oscillator or external clock input is stopped. Performance of this operation, however, cannot be guaranteed.

## 6. Power supply pins ( $V_{CC}/V_{SS}$ )

- If there are multiple  $V_{CC}$  and  $V_{SS}$  pins, from the point of view of device design, pins to be of the same potential are connected inside of the device to prevent such malfunctioning as latch up.

To reduce unnecessary radiation, prevent malfunctioning of the strobe signal due to the rise of ground level, and observe the standard for total output current, be sure to connect the  $V_{CC}$  and  $V_{SS}$  pins to the power supply and ground externally.

Connect  $V_{CC}$  and  $V_{SS}$  pins to the device from the current supply source at a low impedance.

- As a measure against power supply noise, connect a capacitor of about 0.1  $\mu\text{F}$  as a bypass capacitor between  $V_{CC}$  and  $V_{SS}$  pins in the vicinity of  $V_{CC}$  and  $V_{SS}$  pins of the device.

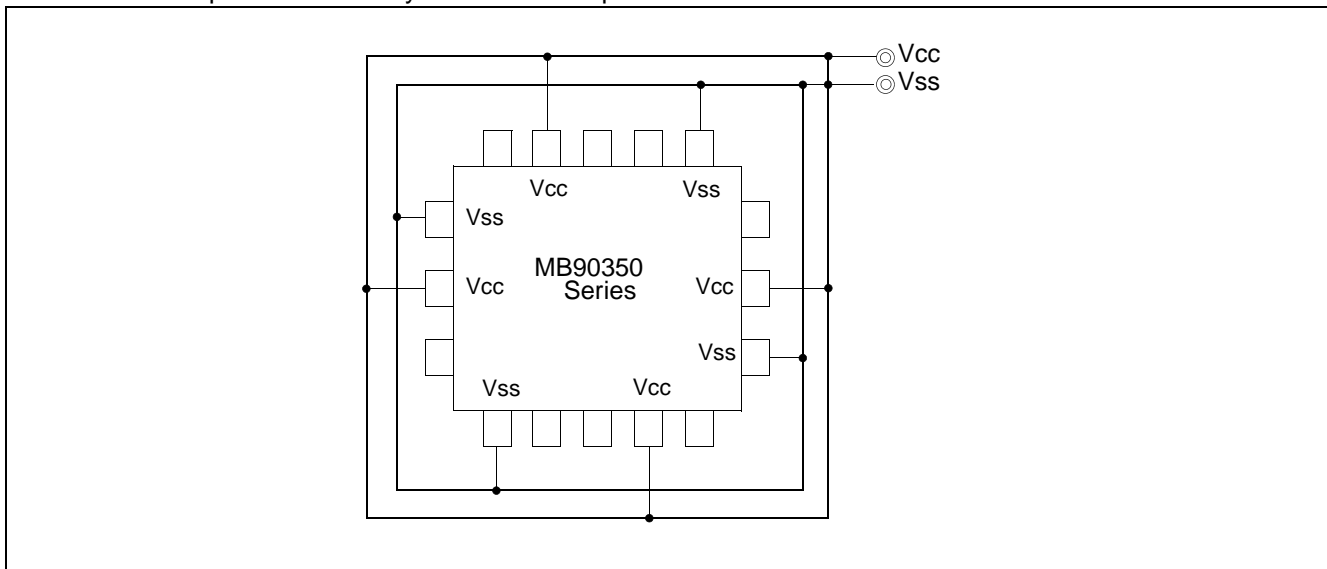

## 7. Pull-up/down resistors

The MB90350 series does not support internal pull-up/down resistors (Port 0 to Port 3: built-in pull-up resistors). Use external components where needed.

## 8. Crystal Oscillator Circuit

Noises around X0 or X1 pins may be possible causes of abnormal operations. Make sure to provide bypass capacitors via shortest distance from X0, X1 pins, crystal oscillator (or ceramic resonator) and ground lines, and make sure, to the utmost effort, that lines of oscillation circuit do not cross the lines of other circuits.

It is highly recommended to provide a printed circuit board artwork surrounding X0 and X1 pins with a ground area for stabilizing the operation.

Please ask the crystal maker to evaluate the oscillational characteristics of the crystal and this device.

# MB90350 Series

## 9. Turning-on Sequence of Power Supply to A/D Converter and Analog Inputs

Make sure to turn on the A/D converter power supply ( $AV_{CC}$ ,  $AVRH$ ) and analog inputs ( $AN0$  to  $AN14$ ) after turning-on the digital power supply ( $V_{CC}$ ).

Turn-off the digital power after turning off the A/D converter power supply and analog inputs. In this case, make sure that the voltage does not exceed  $AVRH$  or  $AV_{CC}$  (turning on/off the analog and digital power supplies simultaneously is acceptable).

## 10. Connection of Unused Pins of A/D Converter if A/D Converter is used

Connect unused pins of A/D converter to  $AV_{CC} = V_{CC}$ ,  $AV_{SS} = AVRH = V_{SS}$ .

## 11. Notes on Energization

To prevent the internal regulator circuit from malfunctioning, set the voltage rise time during energization at  $50 \mu s$  or more ( $0.2 V$  to  $2.7 V$ ).

## 12. Stabilization of power supply voltage

A sudden change in the power supply voltage may cause the device to malfunction even within the specified  $V_{CC}$  power supply voltage operating range. Therefore, the  $V_{CC}$  power supply voltage should be stabilized.

For reference, the power supply voltage should be controlled so that  $V_{CC}$  ripple variations (peak-to-peak value) at commercial frequencies ( $50 Hz$  to  $60 Hz$ ) fall below 10% of the standard  $V_{CC}$  power supply voltage and the coefficient of fluctuation does not exceed  $0.1 V/ms$  at instantaneous power switching.

## 13. Initialization

In the device, there are internal registers which are initialized only by a power-on reset. To initialize these registers, turn on the power again.

## 14. Port 0 to port 3 output during Power-on (External-bus mode)

As shown below, when power is turned on in external-bus mode, there is a possibility that output signal of Port 0 to Port 3 might be unstable.

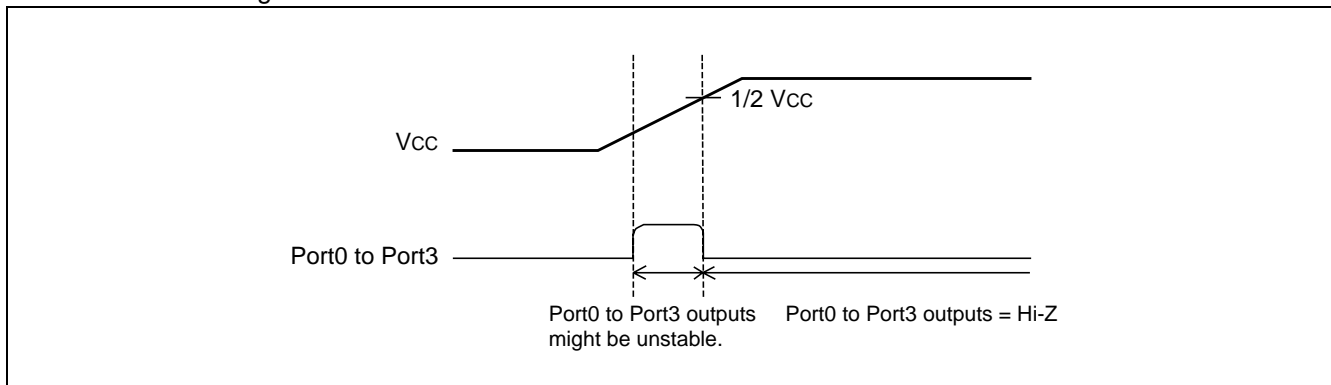

## 15. Notes on using CAN Function

To use CAN function, please set "1" to DIRECT bit of CAN direct mode register (CDMR).

If DIRECT bit is set to "0" (initial value), wait states will be performed when accessing CAN registers.

Note : Please refer to section "22.15 CAN Direct Mode Register" in Hardware Manual of MB90350 series for detail of CAN direct mode register.

## 16. Flash security Function

The security byte is located in the area of the flash memory.

If protection code 01<sub>H</sub> is written in the security byte, the flash memory is in the protected state by security.

Therefore please do not write 01<sub>H</sub> in this address if you do not use the security function.

Please refer to following table for the address of the security byte.

	Flash memory size	Address for security bit
MB90F352(S) MB90F352A(S) MB90F352TA(S) MB90F357A(S) MB90F357TA(S)	Embedded 1 Mbit Flash Memory	FE0001 <sub>H</sub>

## 17. Correspondence with T<sub>A</sub> = +105 °C or more

If used exceeding T<sub>A</sub> = +105 °C, please contact Fujitsu sales representatives for reliability limitations.

## 18. Low voltage/CPU operation reset circuit

The low voltage detection reset circuit is a function that monitors power supply voltage in order to detect when a voltage drops below a given voltage level. When a low voltage condition is detected, an internal reset signal is generated.

The CPU operation detection reset circuit is a 20-bit counter that uses oscillation as a count clock and generates an internal reset signal if not cleared within a given time after startup.

### (1) Low voltage detection reset circuit

Detection voltage
4.0 V ± 0.3 V

When a low voltage condition is detected, the low voltage detection flag (LVRC : LVRF) is set to "1" and an internal reset signal is output.

Because the low voltage detection reset circuit continues to operate even in stop mode, detection of a low voltage condition generates an internal reset and releases stop mode.

During an internal RAM write cycle, low voltage reset is generated after the completion of writing. During the output of this internal reset, the reset output from the low voltage detection reset circuit is suppressed.

### (2) CPU operation detection reset circuit

The CPU operation detection reset circuit is a counter that prevents program runaway. The counter starts automatically after a power-on reset, and must be continually cleared within a given time. If the given time interval elapses and the counter has not been cleared, a cause such as infinite program looping is assumed and an internal reset signal is generated. The internal reset generated from the CPU operation detection circuit has a width of 5 machine cycles.

Interval time
$2^{20}/F_c$ (approx. 262 ms*)

\* : This value assumes the interval time at an oscillation clock frequency of 4 MHz.

During recovery from standby mode, the detection period is the maximum interval plus 20 μs.

# MB90350 Series

This circuit does not operate in modes where CPU operation is stopped.

The CPU operation detection reset circuit counter is cleared under any of the following conditions.

- “0” writing to CL bit of LVRC register
- Internal reset
- Main oscillation clock stop
- Transit to sleep mode
- Transit to timebase timer mode and watch mode

## 19. Internal CR oscillation circuit

Parameter	Symbol	Value			Unit
		Min	Typ	Max	
Oscillation frequency	$f_{RC}$	50	100	200	kHz
Oscillation stabilization wait time	tstab	—	—	100	$\mu$ s

## ■ BLOCK DIAGRAMS

• MB90V340A-101/102

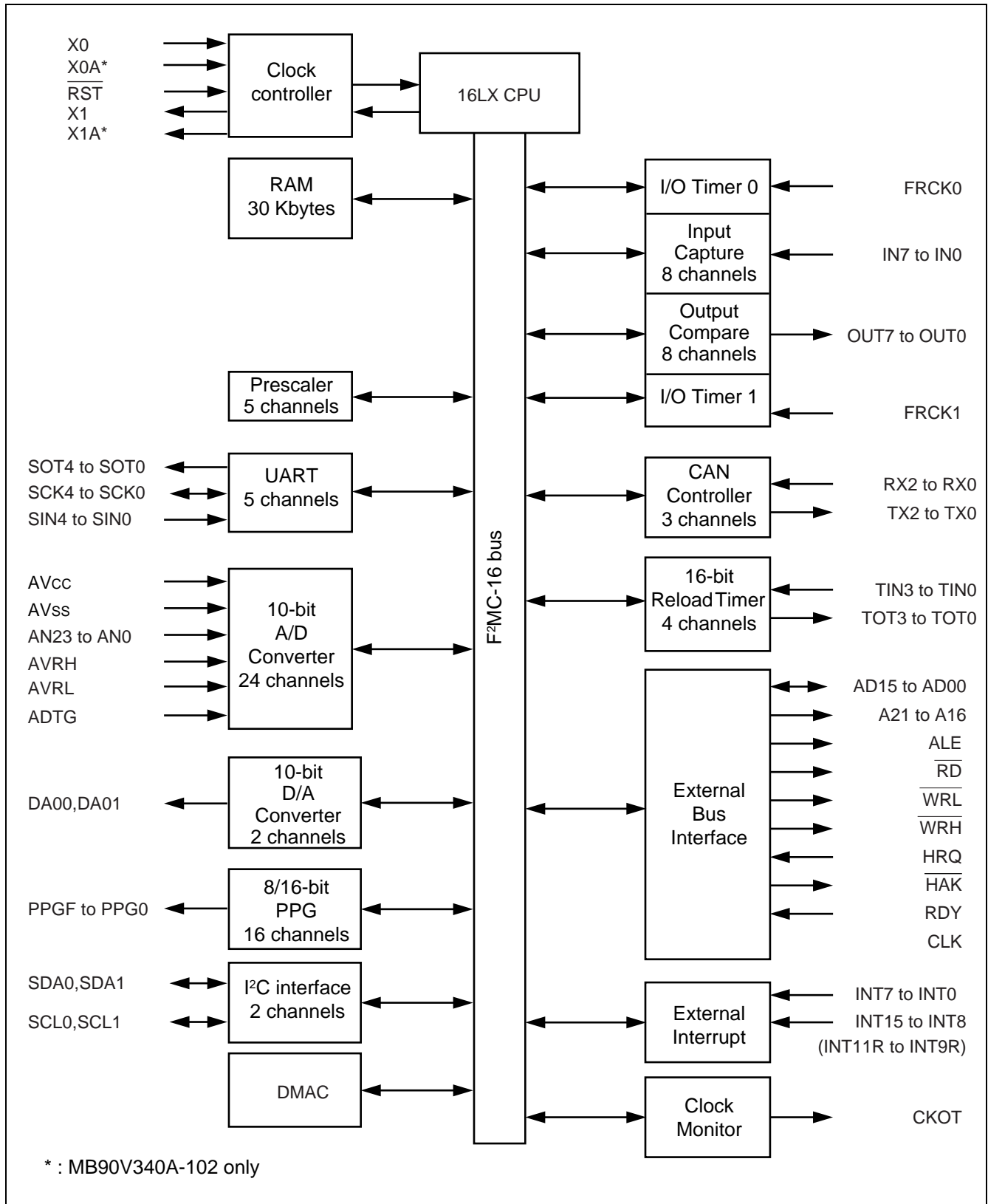

# MB90350 Series

• MB90V340A-103/104

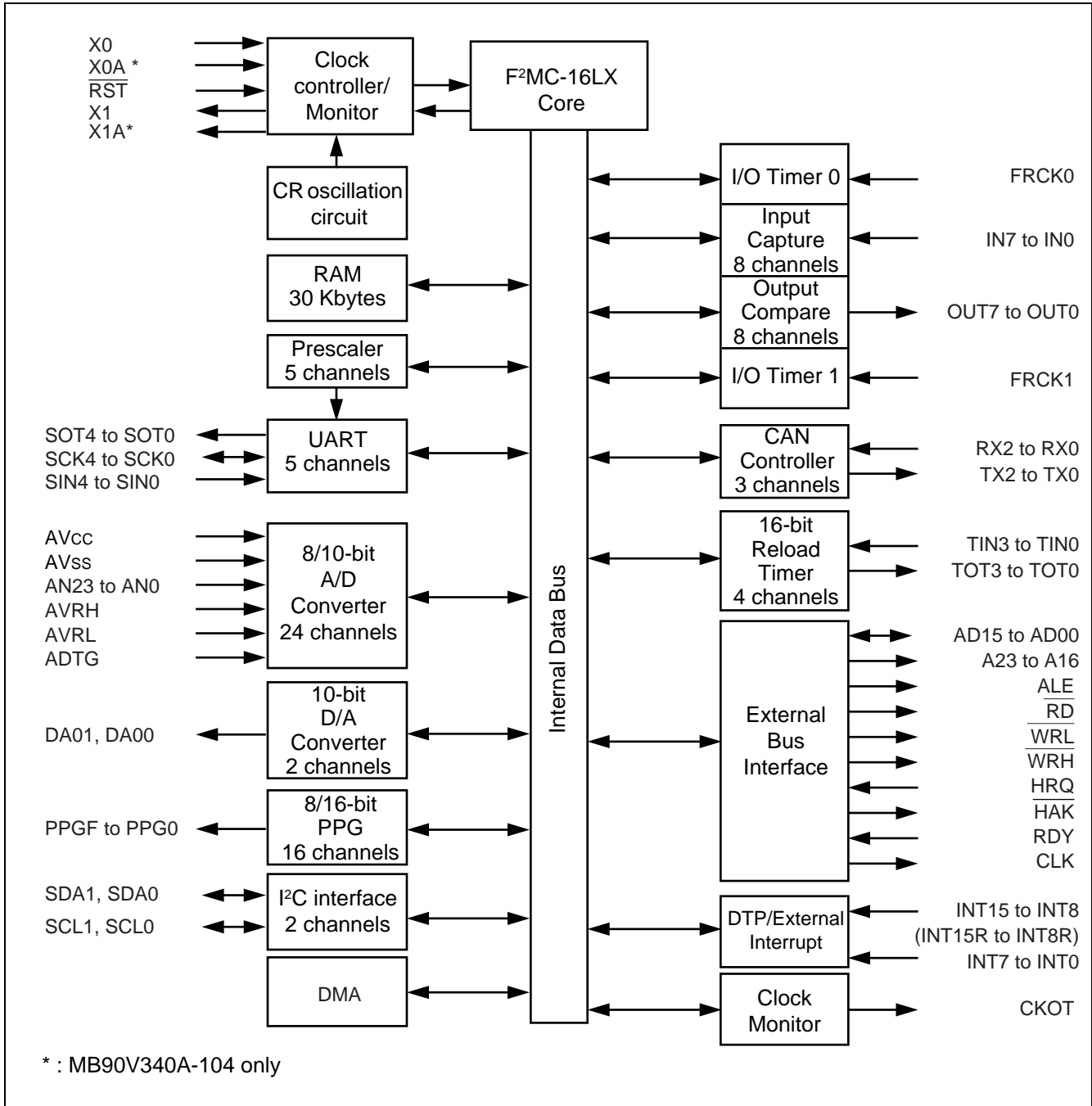

# MB90350 Series

- MB90F352 (S) , MB90F351 (S) , MB90F352A (S) , MB90F352TA (S) , MB90F351A (S) , MB90F351TA (S) , MB90352A (S) , MB90352TA (S) , MB90351A (S) , MB90351TA (S)

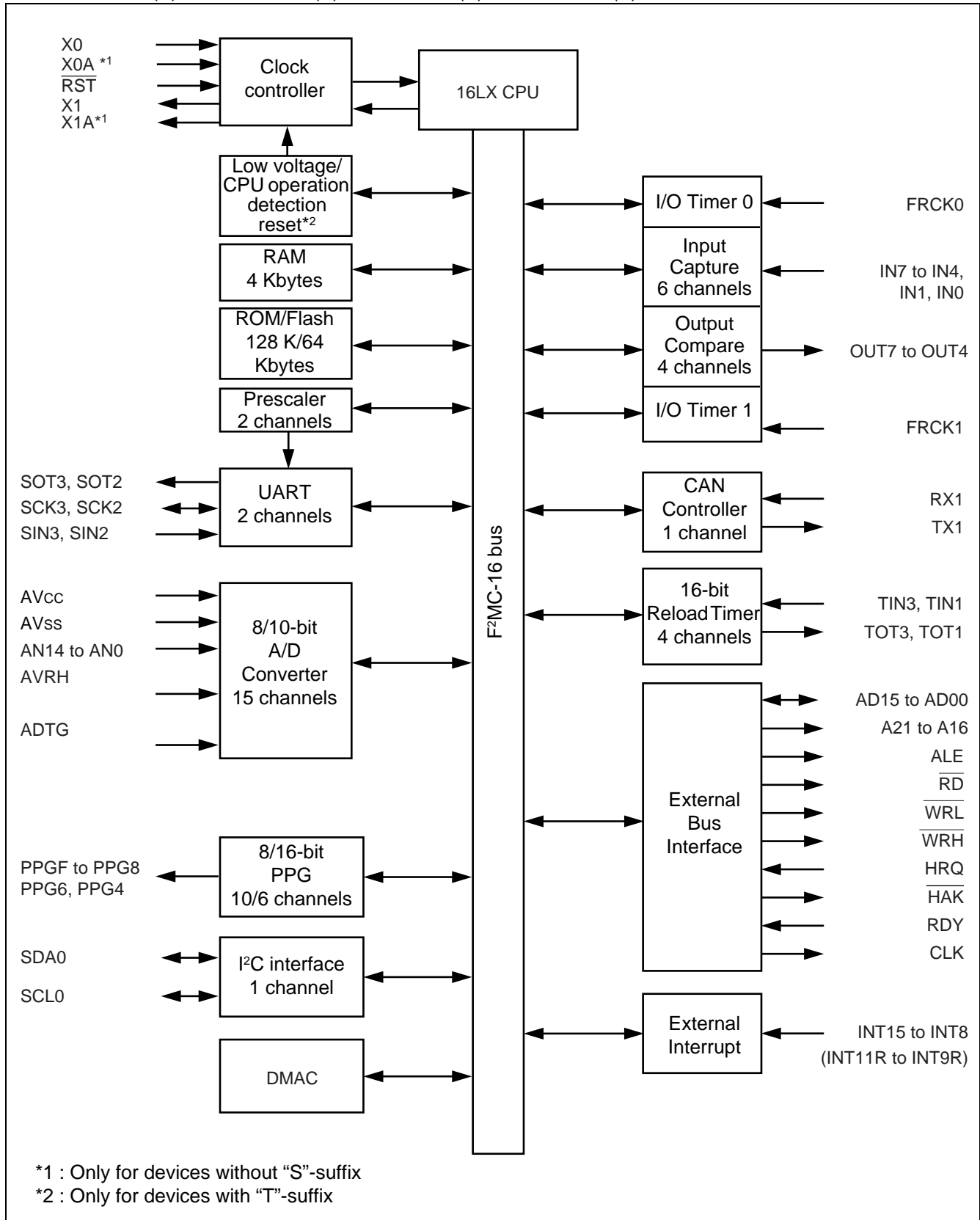

# MB90350 Series

- MB90F357A (S) , MB90F357TA (S) , MB90F356A (S) , MB90F356TA (S) , MB90357A (S) , MB90357TA (S) , MB90356A (S) , MB90356TA (S)

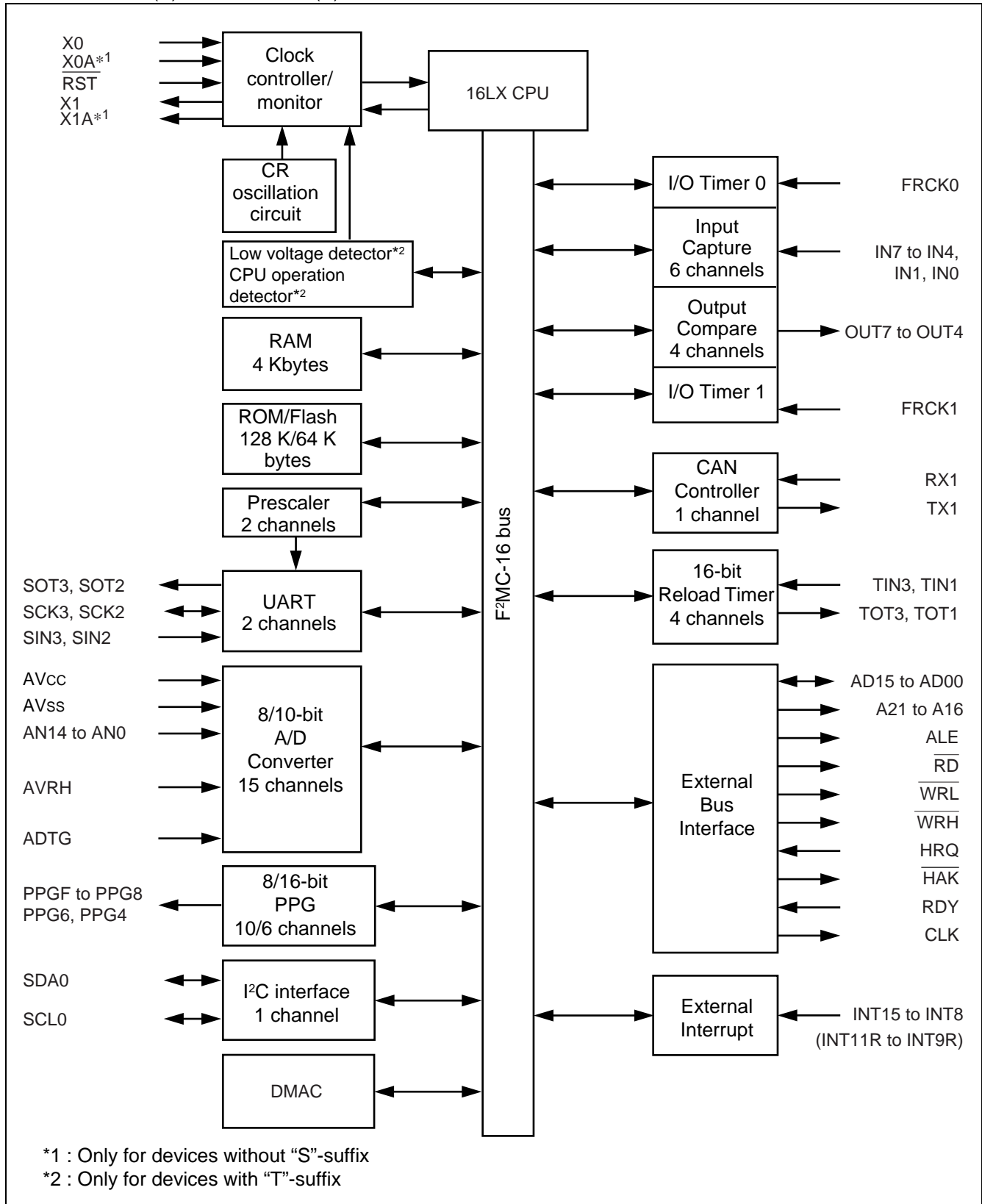

## MEMORY MAP

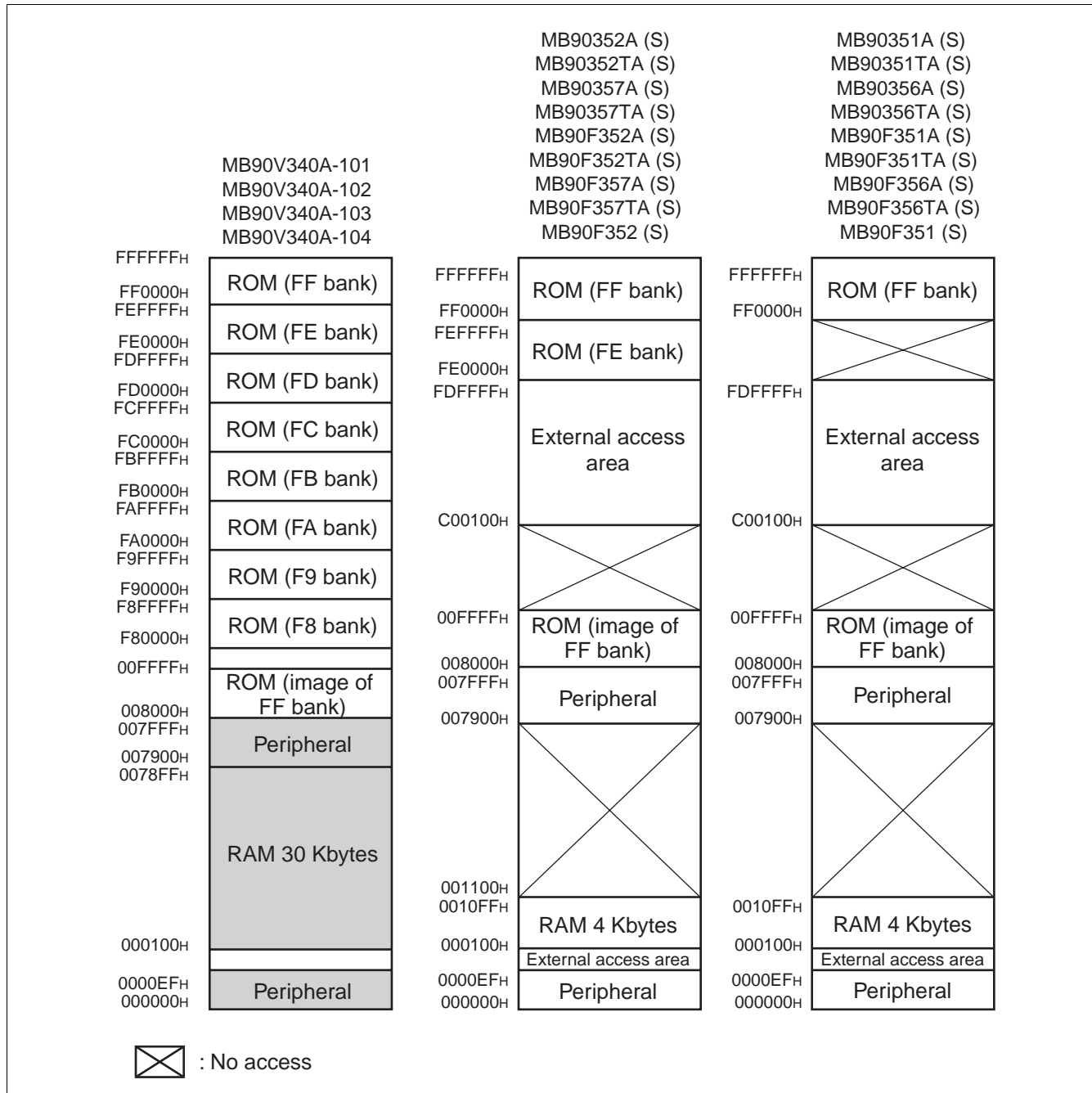

Note : The high-order portion of bank 00 gives the image of the FF bank ROM to make the small model of the C compiler effective. Since the low-order 16 bits are the same, the table in ROM can be referenced without using the far specification in the pointer declaration.

For example, an attempt to access 00C000H accesses the value at FFC000H in ROM.

The ROM area in bank FF exceeds 32 Kbytes, and its entire image cannot be shown in bank 00.

The image between FF8000H and FFFFFFFH is visible in bank 00, while the image between FF0000H and FF7FFFH is visible only in bank FF.

# MB90350 Series

## ■ I/O MAP

Address	Register	Abbreviation	Access	Resource name	Initial value
00 <sub>H</sub>	Port 0 Data Register	PDR0	R/W	Port 0	XXXXXXXX <sub>B</sub>
01 <sub>H</sub>	Port 1 Data Register	PDR1	R/W	Port 1	XXXXXXXX <sub>B</sub>
02 <sub>H</sub>	Port 2 Data Register	PDR2	R/W	Port 2	XXXXXXXX <sub>B</sub>
03 <sub>H</sub>	Port 3 Data Register	PDR3	R/W	Port 3	XXXXXXXX <sub>B</sub>
04 <sub>H</sub>	Port 4 Data Register	PDR4	R/W	Port 4	XXXXXXXX <sub>B</sub>
05 <sub>H</sub>	Port 5 Data Register	PDR5	R/W	Port 5	XXXXXXXX <sub>B</sub>
06 <sub>H</sub>	Port 6 Data Register	PDR6	R/W	Port 6	XXXXXXXX <sub>B</sub>
07 <sub>H</sub> to 0A <sub>H</sub>	Reserved				
0B <sub>H</sub>	Port 5 Analog Input Enable Register	ADER5	R/W	Port 5, A/D	11111111 <sub>B</sub>
0C <sub>H</sub>	Port 6 Analog Input Enable Register	ADER6	R/W	Port 6, A/D	11111111 <sub>B</sub>
0D <sub>H</sub>	Reserved				
0E <sub>H</sub>	Input Level Select Register 0	ILSR0	R/W	Ports	00000000 <sub>B</sub>
0F <sub>H</sub>	Input Level Select Register 1	ILSR1	R/W	Ports	00000000 <sub>B</sub>
10 <sub>H</sub>	Port 0 Direction Register	DDR0	R/W	Port 0	00000000 <sub>B</sub>
11 <sub>H</sub>	Port 1 Direction Register	DDR1	R/W	Port 1	00000000 <sub>B</sub>
12 <sub>H</sub>	Port 2 Direction Register	DDR2	R/W	Port 2	XX000000 <sub>B</sub>
13 <sub>H</sub>	Port 3 Direction Register	DDR3	R/W	Port 3	00000000 <sub>B</sub>
14 <sub>H</sub>	Port 4 Direction Register	DDR4	R/W	Port 4	XX000000 <sub>B</sub>
15 <sub>H</sub>	Port 5 Direction Register	DDR5	R/W	Port 5	X0000000 <sub>B</sub>
16 <sub>H</sub>	Port 6 Direction Register	DDR6	R/W	Port 6	00000000 <sub>B</sub>
17 <sub>H</sub> to 19 <sub>H</sub>	Reserved				
1A <sub>H</sub>	SIN input Level Setting Register	DDRA	W	UART2, UART3	X00XXXX <sub>B</sub>
1B <sub>H</sub>	Reserved				
1C <sub>H</sub>	Port 0 Pull-up Control Register	PUCR0	R/W	Port 0	00000000 <sub>B</sub>
1D <sub>H</sub>	Port 1 Pull-up Control Register	PUCR1	R/W	Port 1	00000000 <sub>B</sub>
1E <sub>H</sub>	Port 2 Pull-up Control Register	PUCR2	R/W	Port 2	00000000 <sub>B</sub>
1F <sub>H</sub>	Port 3 Pull-up Control Register	PUCR3	R/W	Port 3	00000000 <sub>B</sub>
20 <sub>H</sub> to 37 <sub>H</sub>	Reserved				
38 <sub>H</sub>	PPG 4 Operation Mode Control Register	PPGC4	W, R/W	16-bit Programmable Pulse Generator 4/5	0X000X1 <sub>B</sub>
39 <sub>H</sub>	PPG 5 Operation Mode Control Register	PPGC5	W, R/W		0X00001 <sub>B</sub>
3A <sub>H</sub>	PPG 4/5 Count Clock Select Register	PPG45	R/W		000000X0 <sub>B</sub>
3B <sub>H</sub>	Address Detect Control Register 1	PACSR1	R/W	Address Match Detection 1	00000000 <sub>B</sub>

(Continued)

# MB90350 Series

Address	Register	Abbreviation	Access	Resource name	Initial value
3C <sub>H</sub>	PPG 6 Operation Mode Control Register	PPGC6	W, R/W	16-bit Programmable Pulse Generator 6/7	0X000XX1 <sub>B</sub>
3D <sub>H</sub>	PPG 7 Operation Mode Control Register	PPGC7	W, R/W		0X000001 <sub>B</sub>
3E <sub>H</sub>	PPG 6/7 Count Clock Select Register	PPG67	R/W		000000X0 <sub>B</sub>
3F <sub>H</sub>	Reserved				
40 <sub>H</sub>	PPG 8 Operation Mode Control Register	PPGC8	W, R/W	16-bit Programmable Pulse Generator 8/9	0X000XX1 <sub>B</sub>
41 <sub>H</sub>	PPG 9 Operation Mode Control Register	PPGC9	W, R/W		0X000001 <sub>B</sub>
42 <sub>H</sub>	PPG 8/9 Count Clock Select Register	PPG89	R/W		000000X0 <sub>B</sub>
43 <sub>H</sub>	Reserved				
44 <sub>H</sub>	PPG A Operation Mode Control Register	PPGCA	W, R/W	16-bit Programmable Pulse Generator A/B	0X000XX1 <sub>B</sub>
45 <sub>H</sub>	PPG B Operation Mode Control Register	PPGCB	W, R/W		0X000001 <sub>B</sub>
46 <sub>H</sub>	PPG A/B Count Clock Select Register	PPGAB	R/W		000000X0 <sub>B</sub>
47 <sub>H</sub>	Reserved				
48 <sub>H</sub>	PPG C Operation Mode Control Register	PPGCC	W,R/W	16-bit Programmable Pulse Generator C/D	0X000XX1 <sub>B</sub>
49 <sub>H</sub>	PPG D Operation Mode Control Register	PPGCD	W,R/W		0X000001 <sub>B</sub>
4A <sub>H</sub>	PPG C/D Count Clock Select Register	PPGCD	R/W		000000X0 <sub>B</sub>
4B <sub>H</sub>	Reserved				
4C <sub>H</sub>	PPG E Operation Mode Control Register	PPGCE	W,R/W	16-bit Programmable Pulse Generator E/F	0X000XX1 <sub>B</sub>
4D <sub>H</sub>	PPG F Operation Mode Control Register	PPGCF	W,R/W		0X000001 <sub>B</sub>
4E <sub>H</sub>	PPG E/F Count Clock Select Register	PPGEF	R/W		000000X0 <sub>B</sub>
4F <sub>H</sub>	Reserved				
50 <sub>H</sub>	Input Capture Control Status Register 0/1	ICS01	R/W	Input Capture 0/1	00000000 <sub>B</sub>
51 <sub>H</sub>	Input Capture Edge Register 0/1	ICE01	R/W, R		XXX0X0XX <sub>B</sub>
52 <sub>H</sub> , 53 <sub>H</sub>	Reserved				
54 <sub>H</sub>	Input Capture Control Status Register 4/5	ICS45	R/W	Input Capture 4/5	00000000 <sub>B</sub>
55 <sub>H</sub>	Input Capture Edge Register 4/5	ICE45	R		XXXXXXXX <sub>B</sub>
56 <sub>H</sub>	Input Capture Control Status Register 6/7	ICS67	R/W	Input Capture 6/7	00000000 <sub>B</sub>
57 <sub>H</sub>	Input Capture Edge Register 6/7	ICE67	R/W, R		XXX000XX <sub>B</sub>
58 <sub>H</sub> to 5B <sub>H</sub>	Reserved				
5C <sub>H</sub>	Output Compare Control Status Register 4	OCS4	R/W	Output Compare 4/5	0000XX00 <sub>B</sub>
5D <sub>H</sub>	Output Compare Control Status Register 5	OCS5	R/W		0XX00000 <sub>B</sub>

(Continued)

# MB90350 Series

Address	Register	Abbreviation	Access	Resource name	Initial value
5E <sub>H</sub>	Output Compare Control Status Register 6	OCS6	R/W	Output Compare 6/7	0000XX00 <sub>B</sub>
5F <sub>H</sub>	Output Compare Control Status Register 7	OCS7	R/W		0XX00000 <sub>B</sub>
60 <sub>H</sub>	Timer Control Status Register 0	TMCSR0	R/W	16-bit Reload Timer 0	00000000 <sub>B</sub>
61 <sub>H</sub>	Timer Control Status Register 0	TMCSR0	R/W		XXXX0000 <sub>B</sub>
62 <sub>H</sub>	Timer Control Status Register 1	TMCSR1	R/W	16-bit Reload Timer 1	00000000 <sub>B</sub>
63 <sub>H</sub>	Timer Control Status Register 1	TMCSR1	R/W		XXXX0000 <sub>B</sub>
64 <sub>H</sub>	Timer Control Status Register 2	TMCSR2	R/W	16-bit Reload Timer 2	00000000 <sub>B</sub>
65 <sub>H</sub>	Timer Control Status Register 2	TMCSR2	R/W		XXXX0000 <sub>B</sub>
66 <sub>H</sub>	Timer Control Status Register 3	TMCSR3	R/W	16-bit Reload Timer 3	00000000 <sub>B</sub>
67 <sub>H</sub>	Timer Control Status Register 3	TMCSR3	R/W		XXXX0000 <sub>B</sub>
68 <sub>H</sub>	A/D Control Status Register 0	ADCS0	R/W	A/D Converter	000XXXX0 <sub>B</sub>
69 <sub>H</sub>	A/D Control Status Register 1	ADCS1	R/W		0000000X <sub>B</sub>
6A <sub>H</sub>	A/D Data Register 0	ADCR0	R		00000000 <sub>B</sub>
6B <sub>H</sub>	A/D Data Register 1	ADCR1	R		XXXXXXXX00 <sub>B</sub>
6C <sub>H</sub>	ADC Setting Register 0	ADSR0	R/W		00000000 <sub>B</sub>
6D <sub>H</sub>	ADC Setting Register 1	ADSR1	R/W		00000000 <sub>B</sub>
6E <sub>H</sub>	Low Voltage/CPU Operation Detection Reset Control Register	LVRC	R/W, W	Low Voltage/CPU Operation Detection Reset	00111000 <sub>B</sub>
6F <sub>H</sub>	ROM Mirror Function Select Register	ROMM	W	ROM Mirror	XXXXXXXX1 <sub>B</sub>
70 <sub>H</sub> to 7F <sub>H</sub>	Reserved				
80 <sub>H</sub> to 8F <sub>H</sub>	Reserved for CAN Interface 1. Refer to “■ CAN CONTROLLERS”				
90 <sub>H</sub> to 9A <sub>H</sub>	Reserved				
9B <sub>H</sub>	DMA Descriptor Channel Specification Register	DCSR	R/W	DMA	00000000 <sub>B</sub>
9C <sub>H</sub>	DMA Status Register L	DSRL	R/W		00000000 <sub>B</sub>
9D <sub>H</sub>	DMA Status Register H	DSRH	R/W		00000000 <sub>B</sub>
9E <sub>H</sub>	Address Detect Control Register 0	PACSR0	R/W	Address Match Detection 0	00000000 <sub>B</sub>
9F <sub>H</sub>	Delayed Interrupt/Release Register	DIRR	R/W	Delayed Interrupt	XXXXXXXX0 <sub>B</sub>
A0 <sub>H</sub>	Low-power Consumption Mode Control Register	LPMCR	W,R/W	Low Power Consumption Control Circuit	00011000 <sub>B</sub>
A1 <sub>H</sub>	Clock Selection Register	CKSCR	R,R/W	Low Power Consumption Control Circuit	11111100 <sub>B</sub>
A2 <sub>H</sub> , A3 <sub>H</sub>	Reserved				

(Continued)

# MB90350 Series

Address	Register	Abbrevia- tion	Access	Resource name	Initial value
A4 <sub>H</sub>	DMA Stop Status Register	DSSR	R/W	DMA	00000000 <sub>B</sub>
A5 <sub>H</sub>	Automatic Ready Function Selection Register	ARSR	W	External Memory Access	0011XX00 <sub>B</sub>
A6 <sub>H</sub>	External Address Output Control Register	HACR	W		00000000 <sub>B</sub>
A7 <sub>H</sub>	Bus Control Signal Selection Register	ECSR	W		0000000X <sub>B</sub>
A8 <sub>H</sub>	Watchdog Control Register	WDTC	R,W	Watchdog Timer	XXXXX111 <sub>B</sub>
A9 <sub>H</sub>	Timebase Timer Control Register	TBTC	W,R/W	Timebase timer	1XX00100 <sub>B</sub>
AA <sub>H</sub>	Watch Timer Control Register	WTC	R,R/W	Watch Timer	1X001000 <sub>B</sub>
AB <sub>H</sub>	Reserved				
AC <sub>H</sub>	DMA Enable Register L	DERL	R/W	DMA	00000000 <sub>B</sub>
AD <sub>H</sub>	DMA Enable Register H	DERH	R/W		00000000 <sub>B</sub>
AE <sub>H</sub>	Flash Control Status Register (Flash Devices only. Otherwise reserved)	FMCS	R,R/W	Flash Memory	000X0000 <sub>B</sub>
AF <sub>H</sub>	Reserved				
B0 <sub>H</sub>	Interrupt Control Register 00	ICR00	W,R/W	Interrupt Control	00000111 <sub>B</sub>
B1 <sub>H</sub>	Interrupt Control Register 01	ICR01	W,R/W		00000111 <sub>B</sub>
B2 <sub>H</sub>	Interrupt Control Register 02	ICR02	W,R/W		00000111 <sub>B</sub>
B3 <sub>H</sub>	Interrupt Control Register 03	ICR03	W,R/W		00000111 <sub>B</sub>
B4 <sub>H</sub>	Interrupt Control Register 04	ICR04	W,R/W		00000111 <sub>B</sub>
B5 <sub>H</sub>	Interrupt Control Register 05	ICR05	W,R/W		00000111 <sub>B</sub>
B6 <sub>H</sub>	Interrupt Control Register 06	ICR06	W,R/W		00000111 <sub>B</sub>
B7 <sub>H</sub>	Interrupt Control Register 07	ICR07	W,R/W		00000111 <sub>B</sub>
B8 <sub>H</sub>	Interrupt Control Register 08	ICR08	W,R/W		00000111 <sub>B</sub>
B9 <sub>H</sub>	Interrupt Control Register 09	ICR09	W,R/W		00000111 <sub>B</sub>
BA <sub>H</sub>	Interrupt Control Register 10	ICR10	W,R/W		00000111 <sub>B</sub>
BB <sub>H</sub>	Interrupt Control Register 11	ICR11	W,R/W		00000111 <sub>B</sub>
BC <sub>H</sub>	Interrupt Control Register 12	ICR12	W,R/W		00000111 <sub>B</sub>
BD <sub>H</sub>	Interrupt Control Register 13	ICR13	W,R/W		00000111 <sub>B</sub>
BE <sub>H</sub>	Interrupt Control Register 14	ICR14	W,R/W		00000111 <sub>B</sub>
BF <sub>H</sub>	Interrupt Control Register 15	ICR15	W,R/W		00000111 <sub>B</sub>
C0 <sub>H</sub> to C9 <sub>H</sub>	Reserved				

(Continued)

# MB90350 Series

Address	Register	Abbrevia- tion	Access	Resource name	Initial value
CA <sub>H</sub>	External Interrupt Enable Register 1	ENIR1	R/W	External Interrupt 1	00000000 <sub>B</sub>
CB <sub>H</sub>	External Interrupt Source Register 1	EIRR1	R/W		XXXXXXXX <sub>B</sub>
CC <sub>H</sub>	External Interrupt Level Register 1	ELVR1	R/W		00000000 <sub>B</sub>
CD <sub>H</sub>	External Interrupt Level Register 1	ELVR1	R/W		00000000 <sub>B</sub>
CE <sub>H</sub>	External Interrupt Source Select Register	EISSR	R/W		00000000 <sub>B</sub>
CF <sub>H</sub>	PLL/Sub clock Control register	PSCCR	W	PLL	XXXX0000 <sub>B</sub>
D0 <sub>H</sub>	DMA Buffer Address Pointer L	BAPL	R/W	DMA	XXXXXXXX <sub>B</sub>
D1 <sub>H</sub>	DMA Buffer Address Pointer M	BAPM	R/W		XXXXXXXX <sub>B</sub>
D2 <sub>H</sub>	DMA Buffer Address Pointer H	BAPH	R/W		XXXXXXXX <sub>B</sub>
D3 <sub>H</sub>	DMA Control Register	DMACS	R/W		XXXXXXXX <sub>B</sub>
D4 <sub>H</sub>	I/O Register Address Pointer L	IOAL	R/W		XXXXXXXX <sub>B</sub>
D5 <sub>H</sub>	I/O Register Address Pointer H	IOAH	R/W		XXXXXXXX <sub>B</sub>
D6 <sub>H</sub>	Data Counter L	DCTL	R/W		XXXXXXXX <sub>B</sub>
D7 <sub>H</sub>	Data Counter H	DCTH	R/W		XXXXXXXX <sub>B</sub>
D8 <sub>H</sub>	Serial Mode Register 2	SMR2	W,R/W	UART2	00000000 <sub>B</sub>
D9 <sub>H</sub>	Serial Control Register 2	SCR2	W,R/W		00000000 <sub>B</sub>
DA <sub>H</sub>	Reception/Transmission Data Register 2	RDR2/ TDR2	R/W		00000000 <sub>B</sub>
DB <sub>H</sub>	Serial Status Register 2	SSR2	R,R/W		00001000 <sub>B</sub>
DC <sub>H</sub>	Extended Communication Control Register 2	ECCR2	R,W, R/W		000000XX <sub>B</sub>
DD <sub>H</sub>	Extended Status/Control Register 2	ESCR2	R/W		00000100 <sub>B</sub>
DE <sub>H</sub>	Baud Rate Generator Register 20	BGR20	R/W		00000000 <sub>B</sub>
DF <sub>H</sub>	Baud Rate Generator Register 21	BGR21	R/W		00000000 <sub>B</sub>
E0 <sub>H</sub> to EF <sub>H</sub>	Reserved				
F0 <sub>H</sub> to FF <sub>H</sub>	External area				
7900 <sub>H</sub> to 7907 <sub>H</sub>	Reserved				

(Continued)

# MB90350 Series

Address	Register	Abbrevia- tion	Access	Resource name	Initial value
7908 <sub>H</sub>	Reload Register L4	PRL4	R/W	16-bit Programmable Pulse Generator 4/5	XXXXXXXX <sub>B</sub>
7909 <sub>H</sub>	Reload Register H4	PRLH4	R/W		XXXXXXXX <sub>B</sub>
790A <sub>H</sub>	Reload Register L5	PRL5	R/W		XXXXXXXX <sub>B</sub>
790B <sub>H</sub>	Reload Register H5	PRLH5	R/W		XXXXXXXX <sub>B</sub>
790C <sub>H</sub>	Reload Register L6	PRL6	R/W	16-bit Programmable Pulse Generator 6/7	XXXXXXXX <sub>B</sub>
790D <sub>H</sub>	Reload Register H6	PRLH6	R/W		XXXXXXXX <sub>B</sub>
790E <sub>H</sub>	Reload Register L7	PRL7	R/W		XXXXXXXX <sub>B</sub>
790F <sub>H</sub>	Reload Register H7	PRLH7	R/W		XXXXXXXX <sub>B</sub>
7910 <sub>H</sub>	Reload Register L8	PRL8	R/W	16-bit Programmable Pulse Generator 8/9	XXXXXXXX <sub>B</sub>
7911 <sub>H</sub>	Reload Register H8	PRLH8	R/W		XXXXXXXX <sub>B</sub>
7912 <sub>H</sub>	Reload Register L9	PRL9	R/W		XXXXXXXX <sub>B</sub>
7913 <sub>H</sub>	Reload Register H9	PRLH9	R/W		XXXXXXXX <sub>B</sub>
7914 <sub>H</sub>	Reload Register LA	PRLA	R/W	16-bit Programmable Pulse Generator A/B	XXXXXXXX <sub>B</sub>
7915 <sub>H</sub>	Reload Register HA	PRLHA	R/W		XXXXXXXX <sub>B</sub>
7916 <sub>H</sub>	Reload Register LB	PRLB	R/W		XXXXXXXX <sub>B</sub>
7917 <sub>H</sub>	Reload Register HB	PRLHB	R/W		XXXXXXXX <sub>B</sub>
7918 <sub>H</sub>	Reload Register LC	PRLC	R/W	16-bit Programmable Pulse Generator C/D	XXXXXXXX <sub>B</sub>
7919 <sub>H</sub>	Reload Register HC	PRLHC	R/W		XXXXXXXX <sub>B</sub>
791A <sub>H</sub>	Reload Register LD	PRLD	R/W		XXXXXXXX <sub>B</sub>
791B <sub>H</sub>	Reload Register HD	PRLHD	R/W		XXXXXXXX <sub>B</sub>
791C <sub>H</sub>	Reload Register LE	PRLLE	R/W	16-bit Programmable Pulse Generator E/F	XXXXXXXX <sub>B</sub>
791D <sub>H</sub>	Reload Register HE	PRLHE	R/W		XXXXXXXX <sub>B</sub>
791E <sub>H</sub>	Reload Register LF	PRLLF	R/W		XXXXXXXX <sub>B</sub>
791F <sub>H</sub>	Reload Register HF	PRLHF	R/W		XXXXXXXX <sub>B</sub>
7920 <sub>H</sub>	Input Capture Register 0	IPCP0	R	Input Capture 0/1	XXXXXXXX <sub>B</sub>
7921 <sub>H</sub>	Input Capture Register 0	IPCP0	R		XXXXXXXX <sub>B</sub>
7922 <sub>H</sub>	Input Capture Register 1	IPCP1	R		XXXXXXXX <sub>B</sub>
7923 <sub>H</sub>	Input Capture Register 1	IPCP1	R		XXXXXXXX <sub>B</sub>
7924 <sub>H</sub> to 7927 <sub>H</sub>	Reserved				
7928 <sub>H</sub>	Input Capture Register 4	IPCP4	R	Input Capture 4/5	XXXXXXXX <sub>B</sub>
7929 <sub>H</sub>	Input Capture Register 4	IPCP4	R		XXXXXXXX <sub>B</sub>
792A <sub>H</sub>	Input Capture Register 5	IPCP5	R		XXXXXXXX <sub>B</sub>
792B <sub>H</sub>	Input Capture Register 5	IPCP5	R		XXXXXXXX <sub>B</sub>

(Continued)

# MB90350 Series

Address	Register	Abbrevia- tion	Access	Resource name	Initial value
792C <sub>H</sub>	Input Capture Register 6	IPCP6	R	Input Capture 6/7	XXXXXXXX <sub>B</sub>
792D <sub>H</sub>	Input Capture Register 6	IPCP6	R		XXXXXXXX <sub>B</sub>
792E <sub>H</sub>	Input Capture Register 7	IPCP7	R		XXXXXXXX <sub>B</sub>
792F <sub>H</sub>	Input Capture Register 7	IPCP7	R		XXXXXXXX <sub>B</sub>
7930 <sub>H</sub> to 7937 <sub>H</sub>	Reserved				
7938 <sub>H</sub>	Output Compare Register 4	OCCP4	R/W	Output Compare 4/5	XXXXXXXX <sub>B</sub>
7939 <sub>H</sub>	Output Compare Register 4	OCCP4	R/W		XXXXXXXX <sub>B</sub>
793A <sub>H</sub>	Output Compare Register 5	OCCP5	R/W		XXXXXXXX <sub>B</sub>
793B <sub>H</sub>	Output Compare Register 5	OCCP5	R/W		XXXXXXXX <sub>B</sub>
793C <sub>H</sub>	Output Compare Register 6	OCCP6	R/W	Output Compare 6/7	XXXXXXXX <sub>B</sub>
793D <sub>H</sub>	Output Compare Register 6	OCCP6	R/W		XXXXXXXX <sub>B</sub>
793E <sub>H</sub>	Output Compare Register 7	OCCP7	R/W		XXXXXXXX <sub>B</sub>
793F <sub>H</sub>	Output Compare Register 7	OCCP7	R/W		XXXXXXXX <sub>B</sub>
7940 <sub>H</sub>	Timer Data Register 0	TCDT0	R/W	I/O Timer 0	0000000 <sub>B</sub>
7941 <sub>H</sub>	Timer Data Register 0	TCDT0	R/W		0000000 <sub>B</sub>
7942 <sub>H</sub>	Timer Control Status Register 0	TCCSL0	R/W		0000000 <sub>B</sub>
7943 <sub>H</sub>	Timer Control Status Register 0	TCCSH0	R/W		0XXXXXXXX <sub>B</sub>
7944 <sub>H</sub>	Timer Data Register 1	TCDT1	R/W	I/O Timer 1	0000000 <sub>B</sub>
7945 <sub>H</sub>	Timer Data Register 1	TCDT1	R/W		0000000 <sub>B</sub>
7946 <sub>H</sub>	Timer Control Status Register 1	TCCSL1	R/W		0000000 <sub>B</sub>
7947 <sub>H</sub>	Timer Control Status Register 1	TCCSH1	R/W		0XXXXXXXX <sub>B</sub>
7948 <sub>H</sub>	Timer Register 0/Reload Register 0	TMR0/ TMRLR0	R/W	16-bit Reload Timer 0	XXXXXXXX <sub>B</sub>
7949 <sub>H</sub>			R/W		XXXXXXXX <sub>B</sub>
794A <sub>H</sub>	Timer Register 1/Reload Register 1	TMR1/ TMRLR1	R/W	16-bit Reload Timer 1	XXXXXXXX <sub>B</sub>
794B <sub>H</sub>			R/W		XXXXXXXX <sub>B</sub>
794C <sub>H</sub>	Timer Register 2/Reload Register 2	TMR2/ TMRLR2	R/W	16-bit Reload Timer 2	XXXXXXXX <sub>B</sub>
794D <sub>H</sub>			R/W		XXXXXXXX <sub>B</sub>
794E <sub>H</sub>	Timer Register 3/Reload Register 3	TMR3/ TMRLR3	R/W	16-bit Reload Timer 3	XXXXXXXX <sub>B</sub>
794F <sub>H</sub>			R/W		XXXXXXXX <sub>B</sub>

(Continued)

# MB90350 Series

Address	Register	Abbrevia- tion	Access	Resource name	Initial value
7950 <sub>H</sub>	Serial Mode Register 3	SMR3	W, R/W	UART3	00000000 <sub>B</sub>
7951 <sub>H</sub>	Serial Control Register 3	SCR3	W, R/W		00000000 <sub>B</sub>
7952 <sub>H</sub>	Reception/Transmission Data Register 3	RDR3/ TDR3	R/W		00000000 <sub>B</sub>
7953 <sub>H</sub>	Serial Status Register 3	SSR3	R,R/W		00001000 <sub>B</sub>
7954 <sub>H</sub>	Extended Communication Control Register 3	ECCR3	R,W, R/W		000000XX <sub>B</sub>
7955 <sub>H</sub>	Extended Status/Control Register 3	ESCR3	R/W		00000100 <sub>B</sub>
7956 <sub>H</sub>	Baud Rate Generator Register 30	BGR30	R/W		00000000 <sub>B</sub>
7957 <sub>H</sub>	Baud Rate Generator Register 31	BGR31	R/W		00000000 <sub>B</sub>
7958 <sub>H</sub> , 7959 <sub>H</sub>	Reserved				
7960 <sub>H</sub>	Clock Monitor Function Control Register	CSVCR	R, R/W	Clock Monitor	00011100 <sub>B</sub>
7961 <sub>H</sub> to 796D <sub>H</sub>	Reserved				
796E <sub>H</sub>	CAN Direct Mode Register	CDMR	R/W	CAN Clock Sync	XXXXXXXX0 <sub>B</sub>
796F <sub>H</sub>	Reserved				
7970 <sub>H</sub>	I <sup>2</sup> C Bus Status Register 0	IBSR0	R	I <sup>2</sup> C Interface 0	00000000 <sub>B</sub>
7971 <sub>H</sub>	I <sup>2</sup> C Bus Control Register 0	IBCR0	W,R/W		00000000 <sub>B</sub>
7972 <sub>H</sub>	I <sup>2</sup> C 10-bit Slave Address Register 0	ITBAL0	R/W		00000000 <sub>B</sub>
7973 <sub>H</sub>		ITBAH0	R/W		00000000 <sub>B</sub>
7974 <sub>H</sub>	I <sup>2</sup> C 10-bit Slave Address Mask Register 0	ITMKL0	R/W		11111111 <sub>B</sub>
7975 <sub>H</sub>		ITMKH0	R/W		00111111 <sub>B</sub>
7976 <sub>H</sub>	I <sup>2</sup> C 7-bit Slave Address Register 0	ISBA0	R/W		00000000 <sub>B</sub>
7977 <sub>H</sub>	I <sup>2</sup> C 7-bit Slave Address Mask Register 0	ISMK0	R/W		01111111 <sub>B</sub>
7978 <sub>H</sub>	I <sup>2</sup> C data register 0	IDAR0	R/W	00000000 <sub>B</sub>	
7979 <sub>H</sub> , 797A <sub>H</sub>	Reserved				
797B <sub>H</sub>	I <sup>2</sup> C Clock Control Register 0	ICCR0	R/W	I <sup>2</sup> C Interface 0	00011111 <sub>B</sub>
797C <sub>H</sub> to 79A1 <sub>H</sub>	Reserved				
79A2 <sub>H</sub>	Flash Write Control Register 0	FWR0	R/W	Dual Operation Flash	00000000 <sub>B</sub>
79A3 <sub>H</sub>	Flash Write Control Register 1	FWR1	R/W		00000000 <sub>B</sub>
79A4 <sub>H</sub>	Sector Change Setting Register	SSR0	R/W		00XXXXX0 <sub>B</sub>
79A5 <sub>H</sub> to 79C1 <sub>H</sub>	Reserved				

(Continued)

# MB90350 Series

(Continued)

Address	Register	Abbrevia- tion	Access	Resource name	Initial value
79C2 <sub>H</sub>	Setting Prohibited				
79C3 <sub>H</sub> to 79DF <sub>H</sub>	Reserved				
79E0 <sub>H</sub>	Detect Address Setting Register 0	PADR0	R/W	Address Match Detection 0	XXXXXXXX <sub>B</sub>
79E1 <sub>H</sub>	Detect Address Setting Register 0	PADR0	R/W		XXXXXXXX <sub>B</sub>
79E2 <sub>H</sub>	Detect Address Setting Register 0	PADR0	R/W		XXXXXXXX <sub>B</sub>
79E3 <sub>H</sub>	Detect Address Setting Register 1	PADR1	R/W		XXXXXXXX <sub>B</sub>
79E4 <sub>H</sub>	Detect Address Setting Register 1	PADR1	R/W		XXXXXXXX <sub>B</sub>
79E5 <sub>H</sub>	Detect Address Setting Register 1	PADR1	R/W		XXXXXXXX <sub>B</sub>
79E6 <sub>H</sub>	Detect Address Setting Register 2	PADR2	R/W		XXXXXXXX <sub>B</sub>
79E7 <sub>H</sub>	Detect Address Setting Register 2	PADR2	R/W		XXXXXXXX <sub>B</sub>
79E8 <sub>H</sub>	Detect Address Setting Register 2	PADR2	R/W		XXXXXXXX <sub>B</sub>
79E9 <sub>H</sub> to 79EF <sub>H</sub>	Reserved				
79F0 <sub>H</sub>	Detect Address Setting Register 3	PADR3	R/W	Address Match Detection 1	XXXXXXXX <sub>B</sub>
79F1 <sub>H</sub>	Detect Address Setting Register 3	PADR3	R/W		XXXXXXXX <sub>B</sub>
79F2 <sub>H</sub>	Detect Address Setting Register 3	PADR3	R/W		XXXXXXXX <sub>B</sub>
79F3 <sub>H</sub>	Detect Address Setting Register 4	PADR4	R/W		XXXXXXXX <sub>B</sub>
79F4 <sub>H</sub>	Detect Address Setting Register 4	PADR4	R/W		XXXXXXXX <sub>B</sub>
79F5 <sub>H</sub>	Detect Address Setting Register 4	PADR4	R/W		XXXXXXXX <sub>B</sub>
79F6 <sub>H</sub>	Detect Address Setting Register 5	PADR5	R/W		XXXXXXXX <sub>B</sub>
79F7 <sub>H</sub>	Detect Address Setting Register 5	PADR5	R/W		XXXXXXXX <sub>B</sub>
79F8 <sub>H</sub>	Detect Address Setting Register 5	PADR5	R/W		XXXXXXXX <sub>B</sub>
79F9 <sub>H</sub> to 7BFF <sub>H</sub>	Reserved				
7C00 <sub>H</sub> to 7CFF <sub>H</sub>	Reserved for CAN Interface 1. Refer to “■ CAN CONTROLLERS”				
7D00 <sub>H</sub> to 7DFF <sub>H</sub>	Reserved for CAN Interface 1. Refer to “■ CAN CONTROLLERS”				
7E00 <sub>H</sub> to 7FFF <sub>H</sub>	Reserved				

- Notes :
- Initial value of “X” represents unknown value.
  - Any write access to reserved addresses in I/O map should not be performed. A read access to reserved addresses results reading “X”.

## ■ CAN CONTROLLERS

The CAN controller has the following features :

- Conforms to CAN Specification Version 2.0 Part A and B
  - Supports transmission/reception in standard frame and extended frame formats
- Supports transmitting of data frames by receiving remote frames
- 16 transmitting/receiving message buffers
  - 29-bit ID and 8-byte data
  - Multi-level message buffer configuration
- Provides full-bit comparison, full-bit mask, acceptance register 0/acceptance register 1 for each message buffer as ID acceptance mask
  - Two acceptance mask registers in either standard frame format or extended frame formats
- Bit rate programmable from 10 Kbps to 2 Mbps (when input clock is at 16 MHz)

**List of Control Registers**

Address	Register	Abbreviation	Access	Initial Value
CAN1				
000080 <sub>H</sub>	Message buffer enable register	BVALR	R/W	00000000 <sub>B</sub>
000081 <sub>H</sub>				00000000 <sub>B</sub>
000082 <sub>H</sub>	Transmit request register	TREQR	R/W	00000000 <sub>B</sub>
000083 <sub>H</sub>				00000000 <sub>B</sub>
000084 <sub>H</sub>	Transmit cancel register	TCANR	W	00000000 <sub>B</sub>
000085 <sub>H</sub>				00000000 <sub>B</sub>
000086 <sub>H</sub>	Transmission complete register	TCR	R/W	00000000 <sub>B</sub>
000087 <sub>H</sub>				00000000 <sub>B</sub>
000088 <sub>H</sub>	Receive complete register	RCR	R/W	00000000 <sub>B</sub>
000089 <sub>H</sub>				00000000 <sub>B</sub>
00008A <sub>H</sub>	Remote request receiving register	RRTRR	R/W	00000000 <sub>B</sub>
00008B <sub>H</sub>				00000000 <sub>B</sub>
00008C <sub>H</sub>	Receive overrun register	ROVRR	R/W	00000000 <sub>B</sub>
00008D <sub>H</sub>				00000000 <sub>B</sub>
00008E <sub>H</sub>	Reception interrupt enable register	RIER	R/W	00000000 <sub>B</sub>
00008F <sub>H</sub>				00000000 <sub>B</sub>

(Continued)

# MB90350 Series

(Continued)

Address	Register	Abbreviation	Access	Initial Value
<b>CAN1</b>				
007D00 <sub>H</sub>	Control status register	CSR	R/W, W R/W, R	0XXXX0X1 <sub>B</sub> 00XXX000 <sub>B</sub>
007D01 <sub>H</sub>				
007D02 <sub>H</sub>	Last event indicator register	LEIR	R/W	000X0000 <sub>B</sub> XXXXXXXX <sub>B</sub>
007D03 <sub>H</sub>				
007D04 <sub>H</sub>	Receive/transmit error counter	RTEC	R	00000000 <sub>B</sub> 00000000 <sub>B</sub>
007D05 <sub>H</sub>				
007D06 <sub>H</sub>	Bit timing register	BTR	R/W	11111111 <sub>B</sub> X1111111 <sub>B</sub>
007D07 <sub>H</sub>				
007D08 <sub>H</sub>	IDE register	IDER	R/W	XXXXXXXX <sub>B</sub> XXXXXXXX <sub>B</sub>
007D09 <sub>H</sub>				
007D0A <sub>H</sub>	Transmit RTR register	TRTRR	R/W	00000000 <sub>B</sub> 00000000 <sub>B</sub>
007D0B <sub>H</sub>				
007D0C <sub>H</sub>	Remote frame receive waiting register	RFWTR	R/W	XXXXXXXX <sub>B</sub> XXXXXXXX <sub>B</sub>
007D0D <sub>H</sub>				
007D0E <sub>H</sub>	Transmit interrupt enable register	TIER	R/W	00000000 <sub>B</sub> 00000000 <sub>B</sub>
007D0F <sub>H</sub>				
007D10 <sub>H</sub>	Acceptance mask select register	AMSR	R/W	XXXXXXXX <sub>B</sub> XXXXXXXX <sub>B</sub>
007D11 <sub>H</sub>				
007D12 <sub>H</sub>				XXXXXXXX <sub>B</sub> XXXXXXXX <sub>B</sub>
007D13 <sub>H</sub>				
007D14 <sub>H</sub>	Acceptance mask register 0	AMR0	R/W	XXXXXXXX <sub>B</sub> XXXXXXXX <sub>B</sub>
007D15 <sub>H</sub>				
007D16 <sub>H</sub>				XXXXXXXX <sub>B</sub> XXXXXXXX <sub>B</sub>
007D17 <sub>H</sub>				
007D18 <sub>H</sub>	Acceptance mask register 1	AMR1	R/W	XXXXXXXX <sub>B</sub> XXXXXXXX <sub>B</sub>
007D19 <sub>H</sub>				
007D1A <sub>H</sub>				XXXXXXXX <sub>B</sub> XXXXXXXX <sub>B</sub>
007D1B <sub>H</sub>				

List of Message Buffers (ID Registers)

Address	Register	Abbreviation	Access	Initial Value
<b>CAN1</b>				
007C00 <sub>H</sub> to 007C1F <sub>H</sub>	General-purpose RAM	—	R/W	XXXXXXXX <sub>B</sub> to XXXXXXXX <sub>B</sub>
007C20 <sub>H</sub>	ID register 0	IDR0	R/W	XXXXXXXX <sub>B</sub> XXXXXXXX <sub>B</sub>
007C21 <sub>H</sub>				XXXXXXXX <sub>B</sub> XXXXXXXX <sub>B</sub>
007C22 <sub>H</sub>				XXXXXXXX <sub>B</sub> XXXXXXXX <sub>B</sub>
007C23 <sub>H</sub>				XXXXXXXX <sub>B</sub> XXXXXXXX <sub>B</sub>
007C24 <sub>H</sub>	ID register 1	IDR1	R/W	XXXXXXXX <sub>B</sub> XXXXXXXX <sub>B</sub>
007C25 <sub>H</sub>				XXXXXXXX <sub>B</sub> XXXXXXXX <sub>B</sub>
007C26 <sub>H</sub>				XXXXXXXX <sub>B</sub> XXXXXXXX <sub>B</sub>
007C27 <sub>H</sub>				XXXXXXXX <sub>B</sub> XXXXXXXX <sub>B</sub>
007C28 <sub>H</sub>	ID register 2	IDR2	R/W	XXXXXXXX <sub>B</sub> XXXXXXXX <sub>B</sub>
007C29 <sub>H</sub>				XXXXXXXX <sub>B</sub> XXXXXXXX <sub>B</sub>
007C2A <sub>H</sub>				XXXXXXXX <sub>B</sub> XXXXXXXX <sub>B</sub>
007C2B <sub>H</sub>				XXXXXXXX <sub>B</sub> XXXXXXXX <sub>B</sub>
007C2C <sub>H</sub>	ID register 3	IDR3	R/W	XXXXXXXX <sub>B</sub> XXXXXXXX <sub>B</sub>
007C2D <sub>H</sub>				XXXXXXXX <sub>B</sub> XXXXXXXX <sub>B</sub>
007C2E <sub>H</sub>				XXXXXXXX <sub>B</sub> XXXXXXXX <sub>B</sub>
007C2F <sub>H</sub>				XXXXXXXX <sub>B</sub> XXXXXXXX <sub>B</sub>
007C30 <sub>H</sub>	ID register 4	IDR4	R/W	XXXXXXXX <sub>B</sub> XXXXXXXX <sub>B</sub>
007C31 <sub>H</sub>				XXXXXXXX <sub>B</sub> XXXXXXXX <sub>B</sub>
007C32 <sub>H</sub>				XXXXXXXX <sub>B</sub> XXXXXXXX <sub>B</sub>
007C33 <sub>H</sub>				XXXXXXXX <sub>B</sub> XXXXXXXX <sub>B</sub>
007C34 <sub>H</sub>	ID register 5	IDR5	R/W	XXXXXXXX <sub>B</sub> XXXXXXXX <sub>B</sub>
007C35 <sub>H</sub>				XXXXXXXX <sub>B</sub> XXXXXXXX <sub>B</sub>
007C36 <sub>H</sub>				XXXXXXXX <sub>B</sub> XXXXXXXX <sub>B</sub>
007C37 <sub>H</sub>				XXXXXXXX <sub>B</sub> XXXXXXXX <sub>B</sub>
007C38 <sub>H</sub>	ID register 6	IDR6	R/W	XXXXXXXX <sub>B</sub> XXXXXXXX <sub>B</sub>
007C39 <sub>H</sub>				XXXXXXXX <sub>B</sub> XXXXXXXX <sub>B</sub>
007C3A <sub>H</sub>				XXXXXXXX <sub>B</sub> XXXXXXXX <sub>B</sub>
007C3B <sub>H</sub>				XXXXXXXX <sub>B</sub> XXXXXXXX <sub>B</sub>
007C3C <sub>H</sub>	ID register 7	IDR7	R/W	XXXXXXXX <sub>B</sub> XXXXXXXX <sub>B</sub>
007C3D <sub>H</sub>				XXXXXXXX <sub>B</sub> XXXXXXXX <sub>B</sub>
007C3E <sub>H</sub>				XXXXXXXX <sub>B</sub> XXXXXXXX <sub>B</sub>
007C3F <sub>H</sub>				XXXXXXXX <sub>B</sub> XXXXXXXX <sub>B</sub>

(Continued)

# MB90350 Series

(Continued)

Address	Register	Abbreviation	Access	Initial Value
<b>CAN1</b>				
007C40 <sub>H</sub>	ID register 8	IDR8	R/W	XXXXXXXX <sub>B</sub>
007C41 <sub>H</sub>				XXXXXXXX <sub>B</sub>
007C42 <sub>H</sub>				XXXXXXXX <sub>B</sub>
007C43 <sub>H</sub>				XXXXXXXX <sub>B</sub>
007C44 <sub>H</sub>	ID register 9	IDR9	R/W	XXXXXXXX <sub>B</sub>
007C45 <sub>H</sub>				XXXXXXXX <sub>B</sub>
007C46 <sub>H</sub>				XXXXXXXX <sub>B</sub>
007C47 <sub>H</sub>				XXXXXXXX <sub>B</sub>
007C48 <sub>H</sub>	ID register 10	IDR10	R/W	XXXXXXXX <sub>B</sub>
007C49 <sub>H</sub>				XXXXXXXX <sub>B</sub>
007C4A <sub>H</sub>				XXXXXXXX <sub>B</sub>
007C4B <sub>H</sub>				XXXXXXXX <sub>B</sub>
007C4C <sub>H</sub>	ID register 11	IDR11	R/W	XXXXXXXX <sub>B</sub>
007C4D <sub>H</sub>				XXXXXXXX <sub>B</sub>
007C4E <sub>H</sub>				XXXXXXXX <sub>B</sub>
007C4F <sub>H</sub>				XXXXXXXX <sub>B</sub>
007C50 <sub>H</sub>	ID register 12	IDR12	R/W	XXXXXXXX <sub>B</sub>
007C51 <sub>H</sub>				XXXXXXXX <sub>B</sub>
007C52 <sub>H</sub>				XXXXXXXX <sub>B</sub>
007C53 <sub>H</sub>				XXXXXXXX <sub>B</sub>
007C54 <sub>H</sub>	ID register 13	IDR13	R/W	XXXXXXXX <sub>B</sub>
007C55 <sub>H</sub>				XXXXXXXX <sub>B</sub>
007C56 <sub>H</sub>				XXXXXXXX <sub>B</sub>
007C57 <sub>H</sub>				XXXXXXXX <sub>B</sub>
007C58 <sub>H</sub>	ID register 14	IDR14	R/W	XXXXXXXX <sub>B</sub>
007C59 <sub>H</sub>				XXXXXXXX <sub>B</sub>
007C5A <sub>H</sub>				XXXXXXXX <sub>B</sub>
007C5B <sub>H</sub>				XXXXXXXX <sub>B</sub>
007C5C <sub>H</sub>	ID register 15	IDR15	R/W	XXXXXXXX <sub>B</sub>
007C5D <sub>H</sub>				XXXXXXXX <sub>B</sub>
007C5E <sub>H</sub>				XXXXXXXX <sub>B</sub>
007C5F <sub>H</sub>				XXXXXXXX <sub>B</sub>

**List of Message Buffers (DLC Registers and Data Registers)**

Address	Register	Abbreviation	Access	Initial Value
<b>CAN1</b>				
007C60 <sub>H</sub>	DLC register 0	DLCR0	R/W	XXXXXXXX <sub>B</sub>
007C61 <sub>H</sub>				
007C62 <sub>H</sub>	DLC register 1	DLCR1	R/W	XXXXXXXX <sub>B</sub>
007C63 <sub>H</sub>				
007C64 <sub>H</sub>	DLC register 2	DLCR2	R/W	XXXXXXXX <sub>B</sub>
007C65 <sub>H</sub>				
007C66 <sub>H</sub>	DLC register 3	DLCR3	R/W	XXXXXXXX <sub>B</sub>
007C67 <sub>H</sub>				
007C68 <sub>H</sub>	DLC register 4	DLCR4	R/W	XXXXXXXX <sub>B</sub>
007C69 <sub>H</sub>				
007C6A <sub>H</sub>	DLC register 5	DLCR5	R/W	XXXXXXXX <sub>B</sub>
007C6B <sub>H</sub>				
007C6C <sub>H</sub>	DLC register 6	DLCR6	R/W	XXXXXXXX <sub>B</sub>
007C6D <sub>H</sub>				
007C6E <sub>H</sub>	DLC register 7	DLCR7	R/W	XXXXXXXX <sub>B</sub>
007C6F <sub>H</sub>				
007C70 <sub>H</sub>	DLC register 8	DLCR8	R/W	XXXXXXXX <sub>B</sub>
007C71 <sub>H</sub>				
007C72 <sub>H</sub>	DLC register 9	DLCR9	R/W	XXXXXXXX <sub>B</sub>
007C73 <sub>H</sub>				
007C74 <sub>H</sub>	DLC register 10	DLCR10	R/W	XXXXXXXX <sub>B</sub>
007C75 <sub>H</sub>				
007C76 <sub>H</sub>	DLC register 11	DLCR11	R/W	XXXXXXXX <sub>B</sub>
007C77 <sub>H</sub>				
007C78 <sub>H</sub>	DLC register 12	DLCR12	R/W	XXXXXXXX <sub>B</sub>
007C79 <sub>H</sub>				
007C7A <sub>H</sub>	DLC register 13	DLCR13	R/W	XXXXXXXX <sub>B</sub>
007C7B <sub>H</sub>				
007C7C <sub>H</sub>	DLC register 14	DLCR14	R/W	XXXXXXXX <sub>B</sub>
007C7D <sub>H</sub>				
007C7E <sub>H</sub>	DLC register 15	DLCR15	R/W	XXXXXXXX <sub>B</sub>
007C7F <sub>H</sub>				

(Continued)

# MB90350 Series

Address	Register	Abbreviation	Access	Initial Value
<b>CAN1</b>				
007C80H to 007C87H	Data register 0 (8 bytes)	DTR0	R/W	XXXXXXXX <sub>B</sub> to XXXXXXXX <sub>B</sub>
007C88H to 007C8FH	Data register 1 (8 bytes)	DTR1	R/W	XXXXXXXX <sub>B</sub> to XXXXXXXX <sub>B</sub>
007C90H to 007C97H	Data register 2 (8 bytes)	DTR2	R/W	XXXXXXXX <sub>B</sub> to XXXXXXXX <sub>B</sub>
007C98H to 007C9FH	Data register 3 (8 bytes)	DTR3	R/W	XXXXXXXX <sub>B</sub> to XXXXXXXX <sub>B</sub>
007CA0H to 007CA7H	Data register 4 (8 bytes)	DTR4	R/W	XXXXXXXX <sub>B</sub> to XXXXXXXX <sub>B</sub>
007CA8H to 007CAFH	Data register 5 (8 bytes)	DTR5	R/W	XXXXXXXX <sub>B</sub> to XXXXXXXX <sub>B</sub>
007CB0H to 007CB7H	Data register 6 (8 bytes)	DTR6	R/W	XXXXXXXX <sub>B</sub> to XXXXXXXX <sub>B</sub>
007CB8H to 007CBFH	Data register 7 (8 bytes)	DTR7	R/W	XXXXXXXX <sub>B</sub> to XXXXXXXX <sub>B</sub>
007CC0H to 007CC7H	Data register 8 (8 bytes)	DTR8	R/W	XXXXXXXX <sub>B</sub> to XXXXXXXX <sub>B</sub>
007CC8H to 007CCFH	Data register 9 (8 bytes)	DTR9	R/W	XXXXXXXX <sub>B</sub> to XXXXXXXX <sub>B</sub>
007CD0H to 007CD7H	Data register 10 (8 bytes)	DTR10	R/W	XXXXXXXX <sub>B</sub> to XXXXXXXX <sub>B</sub>
007CD8H to 007CDFH	Data register 11 (8 bytes)	DTR11	R/W	XXXXXXXX <sub>B</sub> to XXXXXXXX <sub>B</sub>
007CE0H to 007CE7H	Data register 12 (8 bytes)	DTR12	R/W	XXXXXXXX <sub>B</sub> to XXXXXXXX <sub>B</sub>
007CE8H to 007CEFH	Data register 13 (8 bytes)	DTR13	R/W	XXXXXXXX <sub>B</sub> to XXXXXXXX <sub>B</sub>

(Continued)

# MB90350 Series

(Continued)

<b>Address</b>	<b>Register</b>	<b>Abbreviation</b>	<b>Access</b>	<b>Initial Value</b>
<b>CAN1</b>				
007CF0 <sub>H</sub> to 007CF7 <sub>H</sub>	Data register 14 (8 bytes)	DTR14	R/W	XXXXXXXX <sub>B</sub> to XXXXXXXX <sub>B</sub>
007CF8 <sub>H</sub> to 007CFF <sub>H</sub>	Data register 15 (8 bytes)	DTR15	R/W	XXXXXXXX <sub>B</sub> to XXXXXXXX <sub>B</sub>

# MB90350 Series

## ■ INTERRUPT FACTORS, INTERRUPT VECTORS, INTERRUPT CONTROL REGISTER

Interrupt cause	EI <sup>2</sup> OS corresponding	DMA ch number	Interrupt vector		Interrupt control register	
			Number	Address	Number	Address
Reset	N	—	#08	FFFFDC <sub>H</sub>	—	—
INT9 instruction	N	—	#09	FFFFD8 <sub>H</sub>	—	—
Exception	N	—	#10	FFFFD4 <sub>H</sub>	—	—
Reserved	N	—	#11	FFFFD0 <sub>H</sub>	ICR00	0000B0 <sub>H</sub>
Reserved	N	—	#12	FFFFCC <sub>H</sub>		
CAN 1 RX / Input Capture 6	Y1	—	#13	FFFFC8 <sub>H</sub>	ICR01	0000B1 <sub>H</sub>
CAN 1 TX/NS / Input Capture 7	Y1	—	#14	FFFFC4 <sub>H</sub>		
I <sup>2</sup> C	N	—	#15	FFFFC0 <sub>H</sub>	ICR02	0000B2 <sub>H</sub>
Reserved	N	—	#16	FFFFBC <sub>H</sub>		
16-bit Reload Timer 0	Y1	0	#17	FFFFB8 <sub>H</sub>	ICR03	0000B3 <sub>H</sub>
16-bit Reload Timer 1	Y1	1	#18	FFFFB4 <sub>H</sub>		
16-bit Reload Timer 2	Y1	2	#19	FFFFB0 <sub>H</sub>	ICR04	0000B4 <sub>H</sub>
16-bit Reload Timer 3	Y1	—	#20	FFFFAC <sub>H</sub>		
PPG 4/5	N	—	#21	FFFFA8 <sub>H</sub>	ICR05	0000B5 <sub>H</sub>
PPG 6/7	N	—	#22	FFFFA4 <sub>H</sub>		
PPG 8/9/C/D	N	—	#23	FFFFA0 <sub>H</sub>	ICR06	0000B6 <sub>H</sub>
PPG A/B/E/F	N	—	#24	FFFF9C <sub>H</sub>		
Timebase Timer	N	—	#25	FFFF98 <sub>H</sub>	ICR07	0000B7 <sub>H</sub>
External Interrupt 8 to 11	Y1	3	#26	FFFF94 <sub>H</sub>		
Watch Timer	N	—	#27	FFFF90 <sub>H</sub>	ICR08	0000B8 <sub>H</sub>
External Interrupt 12 to 15	Y1	4	#28	FFFF8C <sub>H</sub>		
A/D Converter	Y1	5	#29	FFFF88 <sub>H</sub>	ICR09	0000B9 <sub>H</sub>
I/O Timer 0 / I/O Timer 1	N	—	#30	FFFF84 <sub>H</sub>		
Input Capture 4/5	Y1	6	#31	FFFF80 <sub>H</sub>	ICR10	0000BA <sub>H</sub>
Output Compare 4/5	Y1	7	#32	FFFF7C <sub>H</sub>		
Input Capture 0/1	Y1	8	#33	FFFF78 <sub>H</sub>	ICR11	0000BB <sub>H</sub>
Output Compare 6/7	Y1	9	#34	FFFF74 <sub>H</sub>		
Reserved	N	10	#35	FFFF70 <sub>H</sub>	ICR12	0000BC <sub>H</sub>
Reserved	N	11	#36	FFFF6C <sub>H</sub>		
UART 3 RX	Y2	12	#37	FFFF68 <sub>H</sub>	ICR13	0000BD <sub>H</sub>
UART 3 TX	Y1	13	#38	FFFF64 <sub>H</sub>		

(Continued)

(Continued)

Interrupt cause	EI <sup>2</sup> OS corresponding	DMA ch number	Interrupt vector		Interrupt control register	
			Number	Address	Number	Address
UART 2 RX	Y2	14	#39	FFFF60 <sub>H</sub>	ICR14	0000BE <sub>H</sub>
UART 2 TX	Y1	15	#40	FFFF5C <sub>H</sub>		
Flash Memory	N	—	#41	FFFF58 <sub>H</sub>	ICR15	0000BF <sub>H</sub>
Delayed interrupt	N	—	#42	FFFF54 <sub>H</sub>		

Y1 : Usable

Y2 : Usable, with EI<sup>2</sup>OS stop function

N : Unusable

- Notes :
- The peripheral resources sharing the ICR register have the same interrupt level.
  - When two peripheral resources share the ICR register, only one can use EI<sup>2</sup>OS at a time.
  - When either of the two peripheral resources sharing the ICR register specifies EI<sup>2</sup>OS, the other one cannot use interrupts.

# MB90350 Series

## ■ ELECTRICAL CHARACTERISTICS

### 1. Absolute Maximum Ratings

Parameter	Symbol	Rating		Unit	Remarks
		Min	Max		
Power supply voltage*1	$V_{CC}$	$V_{SS} - 0.3$	$V_{SS} + 6.0$	V	
	$AV_{CC}$	$V_{SS} - 0.3$	$V_{SS} + 6.0$	V	$V_{CC} = AV_{CC}$ *2
	$AVRH$	$V_{SS} - 0.3$	$V_{SS} + 6.0$	V	$AV_{CC} \geq AVRH$ *2
Input voltage*1	$V_I$	$V_{SS} - 0.3$	$V_{SS} + 6.0$	V	*3
Output voltage*1	$V_O$	$V_{SS} - 0.3$	$V_{SS} + 6.0$	V	*3
Maximum Clamp Current	$I_{CLAMP}$	-4.0	+4.0	mA	*5
Total Maximum Clamp Current	$\Sigma I_{CLAMP} $	—	40	mA	*5
"L" level maximum output current	$I_{OL}$	—	15	mA	*4
"L" level average output current	$I_{OLAV}$	—	4	mA	*4
"L" level maximum overall output current	$\Sigma I_{OL}$	—	100	mA	*4
"L" level average overall output current	$\Sigma I_{OLAV}$	—	50	mA	*4
"H" level maximum output current	$I_{OH}$	—	-15	mA	*4
"H" level average output current	$I_{OHAV}$	—	-4	mA	*4
"H" level maximum overall output current	$\Sigma I_{OH}$	—	-100	mA	*4
"H" level average overall output current	$\Sigma I_{OHAV}$	—	-50	mA	*4
Power consumption	$P_D$	—	240	mW	MB90F351(S), MB90F352(S) +105 °C < $T_A$ ≤ +125 °C, Normal operation : maximum frequency 16 MHz
		—	320	mW	MB90F351(S), MB90F352(S) -40 °C < $T_A$ ≤ +105 °C, Normal operation : maximum frequency 24 MHz
		—	320	mW	Device other than above
Operating temperature	$T_A$	-40	+105	°C	
		-40	+125	°C	*6
Storage temperature	$T_{STG}$	-55	+150	°C	

(Continued)

(Continued)

- \*1: This parameter is based on  $V_{SS} = AV_{SS} = 0\text{ V}$
- \*2: Set  $AV_{CC}$  and  $V_{CC}$  to the same voltage. Make sure that  $AV_{CC}$  does not exceed  $V_{CC}$  and that the voltage at the analog inputs does not exceed  $AV_{CC}$  when the power is switched on.
- \*3:  $V_I$  and  $V_O$  should not exceed  $V_{CC} + 0.3\text{ V}$ .  $V_I$  should not exceed the specified ratings. However if the maximum current to/from an input is limited by some means with external components, the  $I_{CLAMP}$  rating supersedes the  $V_I$  rating.
- \*4: Applicable to pins: P00 to P07, P10 to P17, P20 to P25, P30 to P37, P40 to P45, P50 to P56, P60 to P67
- \*5:
  - Applicable to pins: P00 to P07, P10 to P17, P20 to P25, P30 to P37, P40 to P45, P50 to P56 (for evaluation device : P50 to P55) , P60 to P67
  - Use within recommended operating conditions.
  - Use at DC voltage (current)
  - The +B signal should always be applied a limiting resistance placed between the +B signal and the microcontroller.
  - The value of the limiting resistance should be set so that when the +B signal is applied the input current to the microcontroller pin does not exceed rated values, either instantaneously or for prolonged periods.
  - Note that when the microcontroller drive current is low, such as in the power saving modes, the +B input potential may pass through the protective diode and increase the potential at the  $V_{CC}$  pin, and this may affect other devices.
  - Note that if a +B signal is input when the microcontroller power supply is off (not fixed at 0 V) , the power supply is provided from the pins, so that incomplete operation may result.
  - Note that if the +B input is applied during power-on, the power supply is provided from the pins and the resulting power supply voltage may not be sufficient to operate the power-on reset.
  - Care must be taken not to leave the +B input pin open.
  - Sample recommended circuits:

- Input/output equivalent circuits

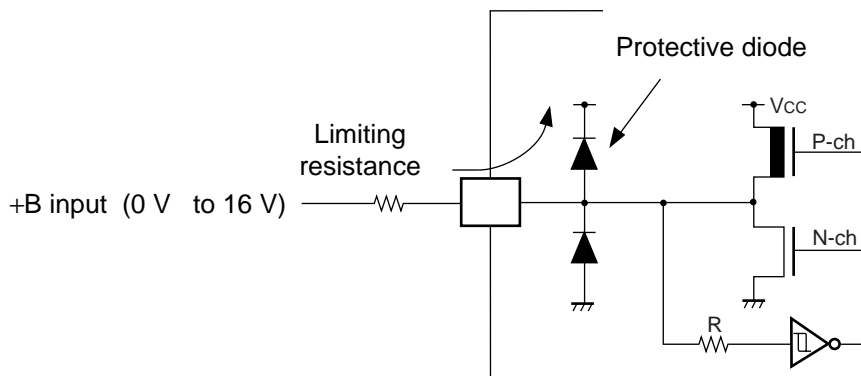

\*6 : If used exceeding  $T_A = +105\text{ }^\circ\text{C}$ , be sure to contact Fujitsu for reliability limitations.

**WARNING:** Semiconductor devices can be permanently damaged by application of stress (voltage, current, temperature, etc.) in excess of absolute maximum ratings. Do not exceed these ratings.

# MB90350 Series

## 2. Recommended Operating Conditions

(V<sub>SS</sub> = AV<sub>SS</sub> = 0 V)

Parameter	Symbol	Value			Unit	Remarks
		Min	Typ	Max		
Power supply voltage	V <sub>CC</sub> , AV <sub>CC</sub>	4.0	5.0	5.5	V	Under normal operation
		3.5	5.0	5.5	V	Under normal operation, when not using the A/D converter and not Flash programming.
		4.5	5.0	5.5	V	When External bus is used.
		3.0	—	5.5	V	Maintains RAM data in stop mode
Smooth capacitor	C <sub>S</sub>	0.1	—	1.0	μF	Use a ceramic capacitor or capacitor of better AC characteristics. Bypass capacitor at the V <sub>CC</sub> pin should be greater than this capacitor.
Operating temperature	T <sub>A</sub>	-40	—	+105	°C	MB90F352(S) f <sub>CP</sub> ≤ 24MHz
		-40	—	+125	°C	*, MB90F352(S) f <sub>CP</sub> ≤ 16MHz, Devices with A-suffix

\* : If used exceeding T<sub>A</sub> = +105 °C, be sure to contact Fujitsu for reliability limitations.

### • C Pin Connection Diagram

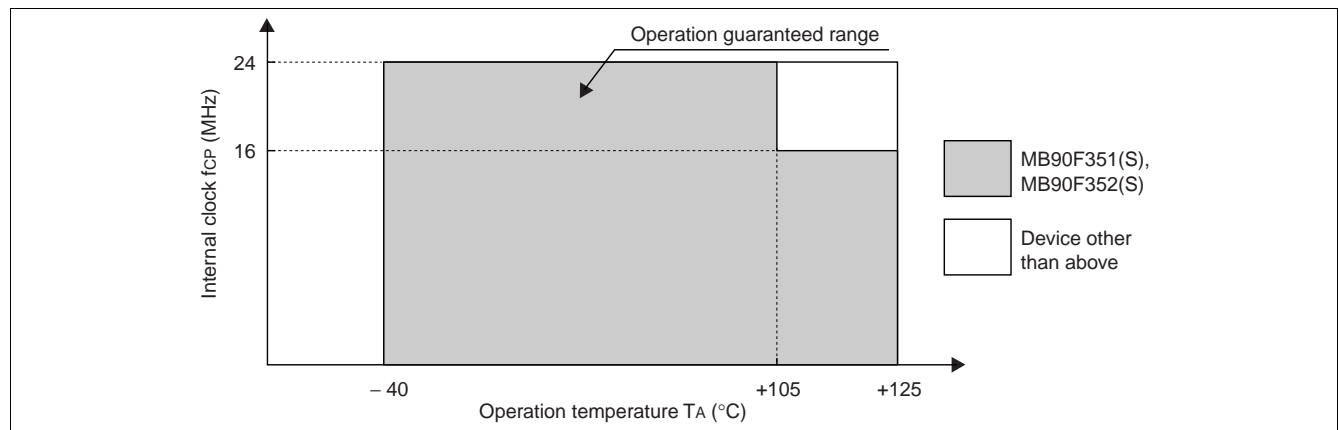
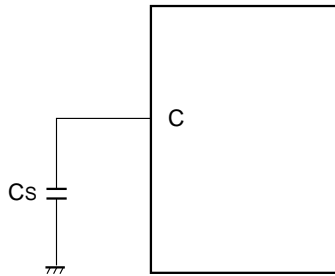

**WARNING:** The recommended operating conditions are required in order to ensure the normal operation of the semiconductor device. All of the device's electrical characteristics are warranted when the device is operated within these ranges.

Always use semiconductor devices within their recommended operating condition ranges. Operation outside these ranges may adversely affect reliability and could result in device failure.

No warranty is made with respect to uses, operating conditions, or combinations not represented on the data sheet. Users considering application outside the listed conditions are advised to contact their FUJITSU representatives beforehand.

## 3. DC Characteristics

(MB90F352(S)/MB90F351(S):  $T_A = -40\text{ }^\circ\text{C}$  to  $+105\text{ }^\circ\text{C}$ ,  $V_{CC} = 5.0\text{ V} \pm 10\%$ ,  $f_{CP} \leq 24\text{ MHz}$ ,  $V_{SS} = AV_{SS} = 0\text{ V}$ )

(MB90F352(S)/MB90F351(S):  $T_A = -40\text{ }^\circ\text{C}$  to  $+125\text{ }^\circ\text{C}$ ,  $V_{CC} = 5.0\text{ V} \pm 10\%$ ,  $f_{CP} \leq 16\text{ MHz}$ ,  $V_{SS} = AV_{SS} = 0\text{ V}$ )

(Device other than above:  $T_A = -40\text{ }^\circ\text{C}$  to  $+125\text{ }^\circ\text{C}$ ,  $V_{CC} = 5.0\text{ V} \pm 10\%$ ,  $f_{CP} \leq 24\text{ MHz}$ ,  $V_{SS} = AV_{SS} = 0\text{ V}$ )

Parameter	Symbol	Pin	Condition	Value			Unit	Remarks
				Min	Typ	Max		
Input H voltage (At $V_{CC} = 5\text{ V} \pm 10\%$ )	$V_{IHS}$	—	—	$0.8 V_{CC}$	—	$V_{CC} + 0.3$	V	Pin inputs if CMOS hysteresis input levels are selected (except P12, P15, P44, P45, P50)
	$V_{IHA}$	—	—	$0.8 V_{CC}$	—	$V_{CC} + 0.3$	V	Pin inputs if AUTOMOTIVE input levels are selected
	$V_{IHT}$	—	—	2.0	—	$V_{CC} + 0.3$	V	Pin inputs if TTL input levels are selected
	$V_{IHS}$	—	—	$0.7 V_{CC}$	—	$V_{CC} + 0.3$	V	P12, P15, P50 inputs if CMOS input levels are selected
	$V_{IHI}$	—	—	$0.7 V_{CC}$	—	$V_{CC} + 0.3$	V	P44, P45 inputs if CMOS hysteresis input levels are selected
	$V_{IHR}$	—	—	$0.8 V_{CC}$	—	$V_{CC} + 0.3$	V	$\overline{RST}$ input pin (CMOS hysteresis)
	$V_{IHM}$	—	—	$V_{CC} - 0.3$	—	$V_{CC} + 0.3$	V	MD input pin
Input L voltage (At $V_{CC} = 5\text{ V} \pm 10\%$ )	$V_{ILS}$	—	—	$V_{SS} - 0.3$	—	$0.2 V_{CC}$	V	Pin inputs if CMOS hysteresis input levels are selected (except P12, P15, P44, P45, P50)
	$V_{ILA}$	—	—	$V_{SS} - 0.3$	—	$0.5 V_{CC}$	V	Pin inputs if AUTOMOTIVE input levels are selected
	$V_{ILT}$	—	—	$V_{SS} - 0.3$	—	0.8	V	Pin inputs if TTL input levels are selected
	$V_{ILS}$	—	—	$V_{SS} - 0.3$	—	$0.3 V_{CC}$	V	P12, P15, P50 inputs if CMOS input levels are selected
	$V_{ILI}$	—	—	$V_{SS} - 0.3$	—	$0.3 V_{CC}$	V	P44, P45 inputs if CMOS hysteresis input levels are selected
	$V_{ILR}$	—	—	$V_{SS} - 0.3$	—	$0.2 V_{CC}$	V	$\overline{RST}$ input pin (CMOS hysteresis)
	$V_{ILM}$	—	—	$V_{SS} - 0.3$	—	$V_{SS} + 0.3$	V	MD input pin
Output H voltage	$V_{OH}$	Normal outputs	$V_{CC} = 4.5\text{ V}$ , $I_{OH} = -4.0\text{ mA}$	$V_{CC} - 0.5$	—	—	V	
Output H voltage	$V_{OHI}$	I <sup>2</sup> C current outputs	$V_{CC} = 4.5\text{ V}$ , $I_{OH} = -3.0\text{ mA}$	$V_{CC} - 0.5$	—	—	V	

(Continued)

# MB90350 Series

(MB90F352(S)/MB90F351(S):  $T_A = -40\text{ }^\circ\text{C}$  to  $+105\text{ }^\circ\text{C}$ ,  $V_{CC} = 5.0\text{ V} \pm 10\%$ ,  $f_{CP} \leq 24\text{ MHz}$ ,  $V_{SS} = AV_{SS} = 0\text{ V}$ )

(MB90F352(S)/MB90F351(S):  $T_A = -40\text{ }^\circ\text{C}$  to  $+125\text{ }^\circ\text{C}$ ,  $V_{CC} = 5.0\text{ V} \pm 10\%$ ,  $f_{CP} \leq 16\text{ MHz}$ ,  $V_{SS} = AV_{SS} = 0\text{ V}$ )

(Device other than above:  $T_A = -40\text{ }^\circ\text{C}$  to  $+125\text{ }^\circ\text{C}$ ,  $V_{CC} = 5.0\text{ V} \pm 10\%$ ,  $f_{CP} \leq 24\text{ MHz}$ ,  $V_{SS} = AV_{SS} = 0\text{ V}$ )

Parameter	Symbol	Pin	Condition	Value			Unit	Remarks
				Min	Typ	Max		
Output L voltage	$V_{OL}$	Normal outputs	$V_{CC} = 4.5\text{ V}$ , $I_{OL} = 4.0\text{ mA}$	—	—	0.4	V	
Output L voltage	$V_{OLI}$	I <sup>2</sup> C current outputs	$V_{CC} = 4.5\text{ V}$ , $I_{OL} = 3.0\text{ mA}$	—	—	0.4	V	
Input leak current	$I_{IL}$	—	$V_{CC} = 5.5\text{ V}$ , $V_{SS} < V_i < V_{CC}$	-1	—	1	$\mu\text{A}$	
Pull-up resistance	$R_{UP}$	P00 to P07, P10 to P17, P20 to P25, P30 to P37, $\overline{RST}$	—	25	50	100	$k\Omega$	
Pull-down resistance	$R_{DOWN}$	MD2	—	25	50	100	$k\Omega$	Except Flash memory devices
Power supply current	$I_{CC}$	$V_{CC}$	$V_{CC} = 5.0\text{ V}$ , Internal frequency : 24 MHz, At normal operation.	—	48	60	mA	
			$V_{CC} = 5.0\text{ V}$ , Internal frequency : 24 MHz, At writing FLASH memory.	—	53	65	mA	Flash memory devices
			$V_{CC} = 5.0\text{ V}$ , Internal frequency : 24 MHz, At erasing FLASH memory.	—	58	70	mA	Flash memory devices
	$I_{CCS}$		$V_{CC} = 5.0\text{ V}$ , Internal frequency : 24 MHz, At Sleep mode.	—	25	35	mA	
	$I_{CTS}$		$V_{CC} = 5.0\text{ V}$ , Internal frequency : 2 MHz, At Main Timer mode	—	0.3	0.8	mA	Devices without "T"-suffix
			—	—	0.4	1.0	mA	Devices with "T"-suffix
	$I_{CTSPLL6}$		$V_{CC} = 5.0\text{ V}$ , Internal frequency : 24 MHz, At PLL Timer mode, external frequency = 4 MHz	—	4	7	mA	
$I_{CCL}$	$V_{CC} = 5.0\text{ V}$ , Internal frequency: 8 kHz, During stopping clock monitor function, At sub clock operation $T_A = +25\text{ }^\circ\text{C}$	—	70	140	$\mu\text{A}$	MB90F351 MB90F352 MB90F351A MB90F352A MB90F356A MB90F357A MB90351A MB90352A MB90356A MB90357A		

(Continued)

# MB90350 Series

(MB90F352(S)/MB90F351(S):  $T_A = -40\text{ }^\circ\text{C}$  to  $+105\text{ }^\circ\text{C}$ ,  $V_{CC} = 5.0\text{ V} \pm 10\%$ ,  $f_{CP} \leq 24\text{ MHz}$ ,  $V_{SS} = AV_{SS} = 0\text{ V}$ )

(MB90F352(S)/MB90F351(S):  $T_A = -40\text{ }^\circ\text{C}$  to  $+125\text{ }^\circ\text{C}$ ,  $V_{CC} = 5.0\text{ V} \pm 10\%$ ,  $f_{CP} \leq 16\text{ MHz}$ ,  $V_{SS} = AV_{SS} = 0\text{ V}$ )

(Device other than above:  $T_A = -40\text{ }^\circ\text{C}$  to  $+125\text{ }^\circ\text{C}$ ,  $V_{CC} = 5.0\text{ V} \pm 10\%$ ,  $f_{CP} \leq 24\text{ MHz}$ ,  $V_{SS} = AV_{SS} = 0\text{ V}$ )

Parameter	Sym- bol	Pin	Condition	Value			Unit	Remarks
				Min	Typ	Max		
Power supply current	I <sub>CC</sub>	V <sub>CC</sub>	V <sub>CC</sub> = 5.0 V, Internal frequency: 8 kHz, During operating clock monitor function, At sub clock operation T <sub>A</sub> = +25°C	—	100	200	μA	MB90F356A MB90F357A MB90356A MB90357A
			V <sub>CC</sub> = 5.0 V, Internal CR oscillation/ 4 division, At sub clock operation T <sub>A</sub> = +25°C	—	100	200	μA	MB90F356AS MB90F357AS MB90356AS MB90357AS
			V <sub>CC</sub> = 5.0 V, Internal frequency: 8 kHz, During stopping clock monitor function, At sub clock operation T <sub>A</sub> = +25°C	—	120	240	μA	MB90F351TA MB90F352TA MB90F356TA MB90F357TA MB90351TA MB90352TA MB90356TA MB90357TA
			V <sub>CC</sub> = 5.0 V, Internal frequency: 8 kHz, During operating clock monitor function, At sub clock operation T <sub>A</sub> = +25°C	—	150	300	μA	MB90F356TA MB90F357TA MB90356TA MB90357TA
			V <sub>CC</sub> = 5.0 V, Internal CR oscillation/ 4 division, At sub clock operation T <sub>A</sub> = +25°C	—	150	300	μA	MB90F356TAS MB90F357TAS MB90356TAS MB90357TAS
	I <sub>CCLS</sub>	V <sub>CC</sub> = 5.0 V, Internal frequency: 8 kHz, During stopping clock monitor function, At sub sleep T <sub>A</sub> = +25°C	—	20	50	μA	MB90F351 MB90F352 MB90F351A MB90F352A MB90F356A MB90F357A MB90351A MB90352A MB90356A MB90357A	

(Continued)

# MB90350 Series

(MB90F352(S)/MB90F351(S):  $T_A = -40\text{ }^\circ\text{C}$  to  $+105\text{ }^\circ\text{C}$ ,  $V_{CC} = 5.0\text{ V} \pm 10\%$ ,  $f_{CP} \leq 24\text{ MHz}$ ,  $V_{SS} = AV_{SS} = 0\text{ V}$ )

(MB90F352(S)/MB90F351(S):  $T_A = -40\text{ }^\circ\text{C}$  to  $+125\text{ }^\circ\text{C}$ ,  $V_{CC} = 5.0\text{ V} \pm 10\%$ ,  $f_{CP} \leq 16\text{ MHz}$ ,  $V_{SS} = AV_{SS} = 0\text{ V}$ )

(Device other than above:  $T_A = -40\text{ }^\circ\text{C}$  to  $+125\text{ }^\circ\text{C}$ ,  $V_{CC} = 5.0\text{ V} \pm 10\%$ ,  $f_{CP} \leq 24\text{ MHz}$ ,  $V_{SS} = AV_{SS} = 0\text{ V}$ )

Parameter	Symbol	Pin	Condition	Value			Unit	Remarks
				Min	Typ	Max		
Power supply current	I <sub>CCLS</sub>	V <sub>CC</sub>	V <sub>CC</sub> = 5.0 V, Internal frequency: 8 kHz, During operating clock monitor function, At sub sleep T <sub>A</sub> = +25°C	—	60	200	μA	MB90F356A MB90F357A MB90356A MB90357A
			V <sub>CC</sub> = 5.0 V, Internal CR oscillation/ 4 division, At sub sleep T <sub>A</sub> = +25°C	—	60	200	μA	MB90F356AS MB90F357AS MB90356AS MB90357AS
			V <sub>CC</sub> = 5.0 V, Internal frequency: 8 kHz, During stopping clock monitor function, At sub sleep T <sub>A</sub> = +25°C	—	70	150	μA	MB90F351TA MB90F352TA MB90F356TA MB90F357TA MB90351TA MB90352TA MB90356TA MB90357TA
			V <sub>CC</sub> = 5.0 V, Internal frequency: 8 kHz, During operating clock monitor function, At sub sleep T <sub>A</sub> = +25°C	—	110	300	μA	MB90F356TA MB90F357TA MB90356TA MB90357TA
			V <sub>CC</sub> = 5.0 V, Internal CR oscillation/ 4 division, At sub sleep T <sub>A</sub> = +25°C	—	110	300	μA	MB90F356TAS MB90F357TAS MB90356TAS MB90357TAS
	I <sub>CCT</sub>	V <sub>CC</sub> = 5.0 V, Internal frequency: 8 kHz, During stopping clock monitor function, At watch mode T <sub>A</sub> = +25°C	—	10	35	μA	MB90F351 MB90F352 MB90F351A MB90F352A MB90F356A MB90F357A MB90351A MB90352A MB90356A MB90357A	

(Continued)

# MB90350 Series

(Continued)

(MB90F352(S)/MB90F351(S):  $T_A = -40\text{ }^\circ\text{C}$  to  $+105\text{ }^\circ\text{C}$ ,  $V_{CC} = 5.0\text{ V} \pm 10\%$ ,  $f_{CP} \leq 24\text{ MHz}$ ,  $V_{SS} = AV_{SS} = 0\text{ V}$ )

(MB90F352(S)/MB90F351(S):  $T_A = -40\text{ }^\circ\text{C}$  to  $+125\text{ }^\circ\text{C}$ ,  $V_{CC} = 5.0\text{ V} \pm 10\%$ ,  $f_{CP} \leq 16\text{ MHz}$ ,  $V_{SS} = AV_{SS} = 0\text{ V}$ )

(Device other than above:  $T_A = -40\text{ }^\circ\text{C}$  to  $+125\text{ }^\circ\text{C}$ ,  $V_{CC} = 5.0\text{ V} \pm 10\%$ ,  $f_{CP} \leq 24\text{ MHz}$ ,  $V_{SS} = AV_{SS} = 0\text{ V}$ )

Parameter	Symbol	Pin	Condition	Value			Unit	Remarks
				Min	Typ	Max		
Power supply current	I <sub>CC</sub>	V <sub>CC</sub>	V <sub>CC</sub> = 5.0 V, Internal frequency: 8 kHz, During operating clock monitor function, At watch mode T <sub>A</sub> = +25°C	—	25	150	μA	MB90F356A MB90F357A MB90356A MB90357A
			V <sub>CC</sub> = 5.0 V, Internal CR oscillation/ 4 division, At watch mode T <sub>A</sub> = +25°C	—	25	150	μA	MB90F356AS MB90F357AS MB90356AS MB90357AS
			V <sub>CC</sub> = 5.0 V, Internal frequency: 8 kHz, During stopping clock monitor function, At watch mode T <sub>A</sub> = +25°C	—	60	140	μA	MB90F351TA MB90F352TA MB90F356TA MB90F357TA MB90351TA MB90352TA MB90356TA MB90357TA
			V <sub>CC</sub> = 5.0 V, Internal frequency: 8 kHz, During operating clock monitor function, At watch mode T <sub>A</sub> = +25°C	—	80	250	μA	MB90F356TA MB90F357TA MB90356TA MB90357TA
			V <sub>CC</sub> = 5.0 V, Internal CR oscillation/ 4 division, At watch mode T <sub>A</sub> = +25°C	—	80	250	μA	MB90F356TAS MB90F357TAS MB90356TAS MB90357TAS
	I <sub>CCH</sub>	V <sub>CC</sub>	V <sub>CC</sub> = 5.0 V, At Stop mode, T <sub>A</sub> = +25°C	—	7	25	μA	Devices without "T"-suffix
				—	60	130	μA	Devices with "T"-suffix
Input capacity	C <sub>IN</sub>	Other than C, AV <sub>CC</sub> , AV <sub>SS</sub> , AVRH, V <sub>CC</sub> , V <sub>SS</sub> ,	—	—	5	15	pF	

# MB90350 Series

## 4. AC Characteristics

### (1) Clock Timing

(MB90F352(S)/MB90F351(S):  $T_A = -40\text{ }^\circ\text{C}$  to  $+105\text{ }^\circ\text{C}$ ,  $V_{CC} = 5.0\text{ V} \pm 10\%$ ,  $f_{CP} \leq 24\text{ MHz}$ ,  $V_{SS} = AV_{SS} = 0\text{ V}$ )

(MB90F352(S)/MB90F351(S):  $T_A = -40\text{ }^\circ\text{C}$  to  $+125\text{ }^\circ\text{C}$ ,  $V_{CC} = 5.0\text{ V} \pm 10\%$ ,  $f_{CP} \leq 16\text{ MHz}$ ,  $V_{SS} = AV_{SS} = 0\text{ V}$ )

(Device other than above:  $T_A = -40\text{ }^\circ\text{C}$  to  $+125\text{ }^\circ\text{C}$ ,  $V_{CC} = 5.0\text{ V} \pm 10\%$ ,  $f_{CP} \leq 24\text{ MHz}$ ,  $V_{SS} = AV_{SS} = 0\text{ V}$ )

Parameter	Symbol	Pin	Value			Unit	Remarks
			Min	Typ	Max		
Clock frequency	$f_c$	X0, X1	3	—	16	MHz	1/2 (at PLL stop) When using an oscillation circuit
			4	—	16	MHz	1 multiplied PLL When using an oscillation circuit
			4	—	12	MHz	2 multiplied PLL When using an oscillation circuit
			4	—	8	MHz	3 multiplied PLL When using an oscillation circuit
			4	—	6	MHz	4 multiplied PLL When using an oscillation circuit
			—	—	4	MHz	6 multiplied PLL When using an oscillation circuit
		X0	3	—	24	MHz	1/2 (at PLL stop), When using an external clock
			4	—	24	MHz	1 multiplied PLL When using an external clock
			4	—	12	MHz	2 multiplied PLL When using an external clock
			4	—	8	MHz	3 multiplied PLL When using an external clock
			4	—	6	MHz	4 multiplied PLL When using an external clock
			—	—	4	MHz	6 multiplied PLL When using an external clock
	$f_{CL}$	X0A, X1A	—	32.768	100	kHz	
Clock cycle time	$t_{CYL}$	X0, X1	62.5	—	333	ns	When using an oscillation circuit
		X0	41.67	—	333	ns	When using an external clock
	$t_{CYLL}$	X0A, X1A	10	30.5	—	$\mu\text{s}$	
Input clock pulse width	$P_{WH}, P_{WL}$	X0	10	—	—	ns	Duty ratio is about 30% to 70%.
	$P_{WHL}, P_{WLL}$	X0A	5	15.2	—	$\mu\text{s}$	
Input clock rise and fall time	$t_{CR}, t_{CF}$	X0	—	—	5	ns	When using an external clock

(Continued)

(Continued)

(MB90F352(S)/MB90F351(S):  $T_A = -40\text{ }^\circ\text{C}$  to  $+105\text{ }^\circ\text{C}$ ,  $V_{CC} = 5.0\text{ V} \pm 10\%$ ,  $f_{CP} \leq 24\text{ MHz}$ ,  $V_{SS} = AV_{SS} = 0\text{ V}$ )

(MB90F352(S)/MB90F351(S):  $T_A = -40\text{ }^\circ\text{C}$  to  $+125\text{ }^\circ\text{C}$ ,  $V_{CC} = 5.0\text{ V} \pm 10\%$ ,  $f_{CP} \leq 16\text{ MHz}$ ,  $V_{SS} = AV_{SS} = 0\text{ V}$ )

(Device other than above:  $T_A = -40\text{ }^\circ\text{C}$  to  $+125\text{ }^\circ\text{C}$ ,  $V_{CC} = 5.0\text{ V} \pm 10\%$ ,  $f_{CP} \leq 24\text{ MHz}$ ,  $V_{SS} = AV_{SS} = 0\text{ V}$ )

Parameter	Symbol	Pin	Value			Unit	Remarks
			Min	Typ	Max		
Internal operating clock frequency (machine clock)	$f_{CP}$	—	1.5	—	24	MHz	MB90F352/(S), MB90F351/(S) When using main clock ( $T_A \leq +105\text{ }^\circ\text{C}$ )
					16		MB90F352/(S), MB90F351/(S) When using main clock ( $T_A \leq +125\text{ }^\circ\text{C}$ )
			1.5	—	24	MHz	Device other than above, When using main clock
	$f_{CPL}$	—	—	8.192	50	kHz	When using sub clock
Internal operating clock cycle time (machine clock)	$t_{CP}$	—	41.67	—	666	ns	MB90F352/(S), MB90F351/(S) When using main clock ( $T_A \leq +105\text{ }^\circ\text{C}$ )
			62.5				MB90F352/(S), MB90F351/(S) When using main clock ( $T_A \leq +125\text{ }^\circ\text{C}$ )
			41.67	—	666	ns	Device other than above, When using main clock
	$t_{CPL}$	—	20	122.1	—	$\mu\text{s}$	When using sub clock

• Clock Timing

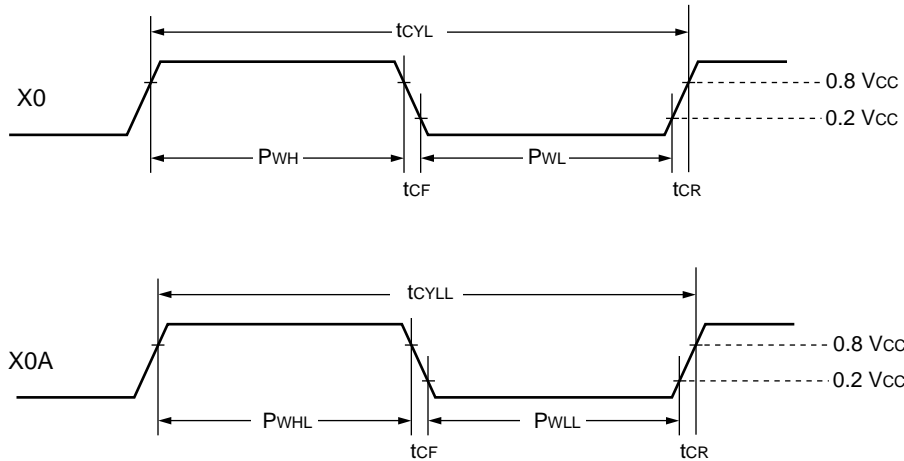

# MB90350 Series

• PLL guaranteed operation range

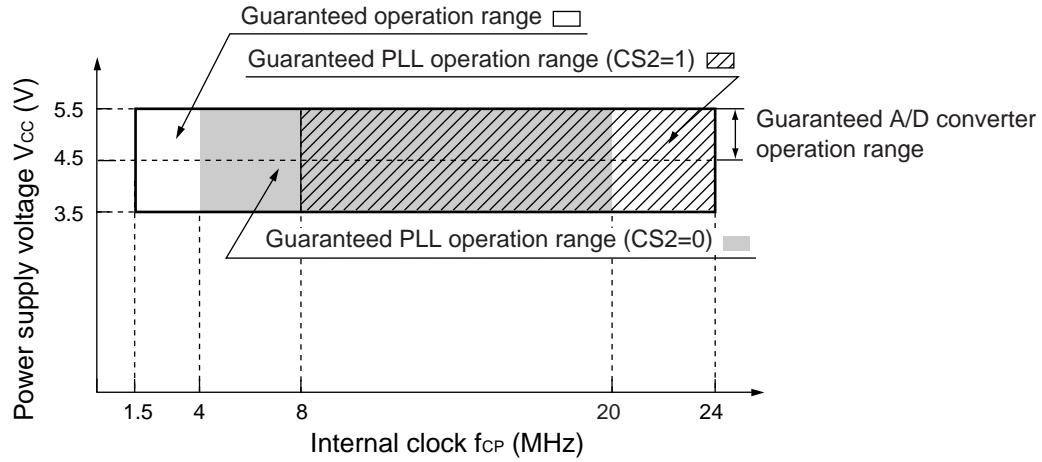

**Guaranteed operation range of MB90350 series**

CS2(bit0 of PSCCR register) = 0

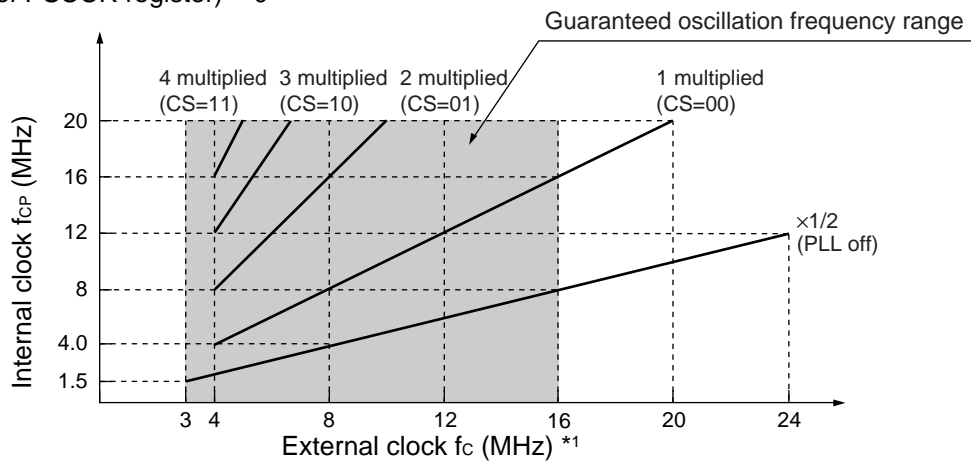

CS2(bit0 of PSCCR register) = 1

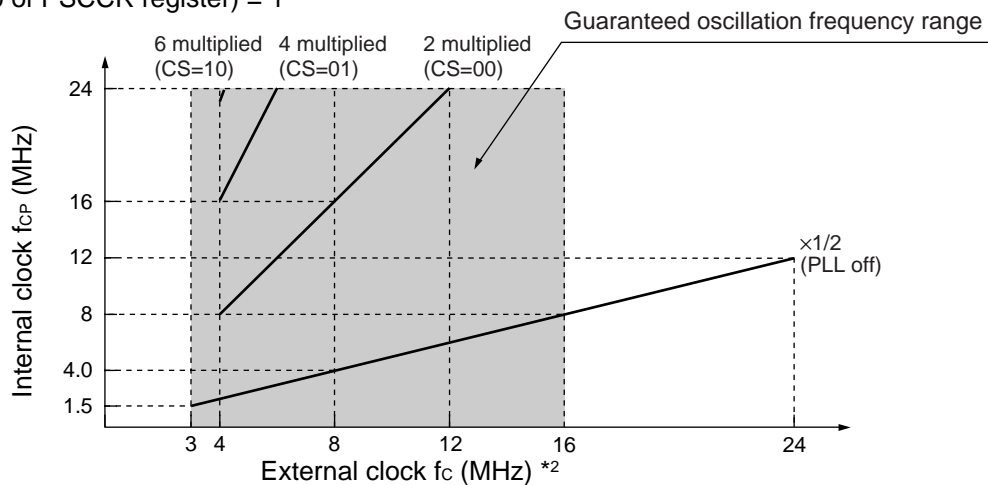

\*1 : Guaranteed 1 multiplied PLL operation range is 4.0 MHz to 20 MHz.

\*2 : When using crystal oscillator or ceramic oscillator, the maximum clock frequency is 16 MHz.

**External clock frequency and internal operation clock frequency**

## (2) Reset Standby Input

(MB90F352(S)/MB90F351(S):  $T_A = -40\text{ }^\circ\text{C}$  to  $+105\text{ }^\circ\text{C}$ ,  $V_{CC} = 5.0\text{ V} \pm 10\%$ ,  $f_{CP} \leq 24\text{ MHz}$ ,  $V_{SS} = AV_{SS} = 0\text{ V}$ )

(MB90F352(S)/MB90F351(S):  $T_A = -40\text{ }^\circ\text{C}$  to  $+125\text{ }^\circ\text{C}$ ,  $V_{CC} = 5.0\text{ V} \pm 10\%$ ,  $f_{CP} \leq 16\text{ MHz}$ ,  $V_{SS} = AV_{SS} = 0\text{ V}$ )

(Device other than above:  $T_A = -40\text{ }^\circ\text{C}$  to  $+125\text{ }^\circ\text{C}$ ,  $V_{CC} = 5.0\text{ V} \pm 10\%$ ,  $f_{CP} \leq 24\text{ MHz}$ ,  $V_{SS} = AV_{SS} = 0\text{ V}$ )

Parameter	Symbol	Pin	Value		Unit	Remarks	
			Min	Max			
Reset input time	$t_{RSTL}$	$\overline{RST}$	500	—	ns	Under normal operation	
			Oscillation time of oscillator* + 100 $\mu\text{s}$		—	$\mu\text{s}$	In Stop mode, Sub Clock mode, Sub Sleep mode and Watch mode
			100	—	$\mu\text{s}$	In Main timer mode and PLL timer mode	

\* : Oscillation time of oscillator is the time that the amplitude reaches 90%.

In the crystal oscillator, the oscillation time is between several ms to tens of ms. In FAR / ceramic oscillators, the oscillation time is between hundreds of  $\mu\text{s}$  to several ms. With an external clock, the oscillation time is 0 ms.

Under normal operation:

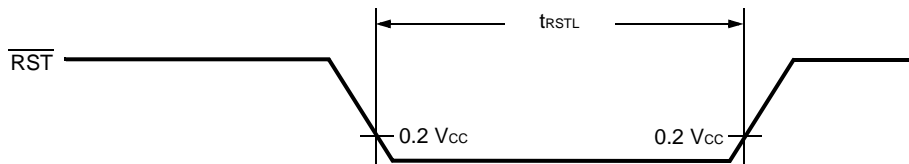

In Stop mode, Sub Clock mode, Sub Sleep mode, Watch mode:

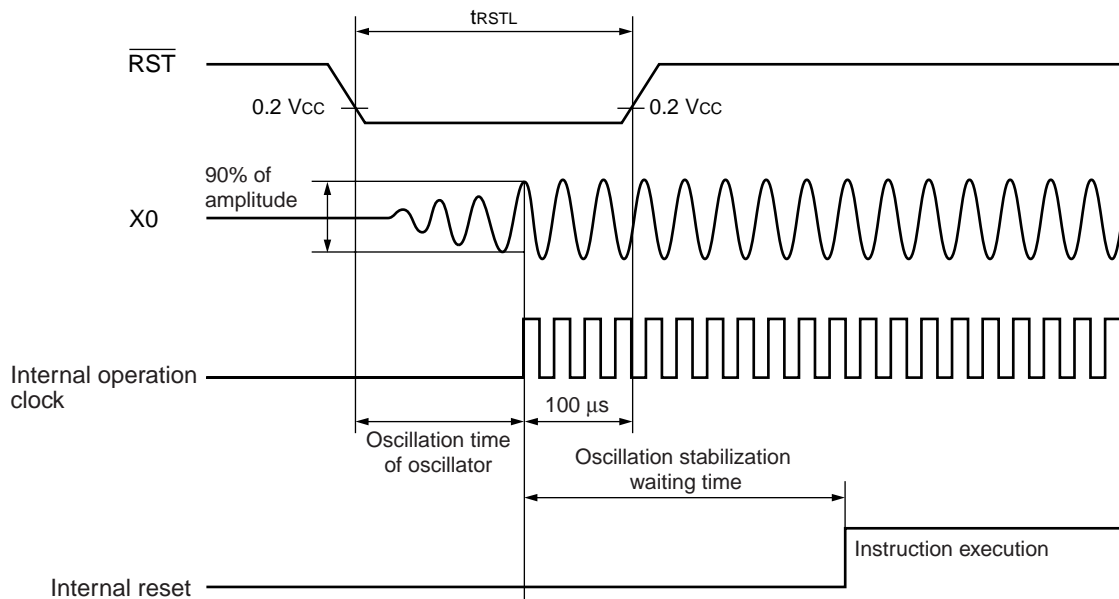

# MB90350 Series

## (3) Power On Reset

(MB90F352(S)/MB90F351(S):  $T_A = -40\text{ }^\circ\text{C}$  to  $+105\text{ }^\circ\text{C}$ ,  $V_{CC} = 5.0\text{ V} \pm 10\%$ ,  $f_{CP} \leq 24\text{ MHz}$ ,  $V_{SS} = AV_{SS} = 0\text{ V}$ )

(MB90F352(S)/MB90F351(S):  $T_A = -40\text{ }^\circ\text{C}$  to  $+125\text{ }^\circ\text{C}$ ,  $V_{CC} = 5.0\text{ V} \pm 10\%$ ,  $f_{CP} \leq 16\text{ MHz}$ ,  $V_{SS} = AV_{SS} = 0\text{ V}$ )

(Device other than above:  $T_A = -40\text{ }^\circ\text{C}$  to  $+125\text{ }^\circ\text{C}$ ,  $V_{CC} = 5.0\text{ V} \pm 10\%$ ,  $f_{CP} \leq 24\text{ MHz}$ ,  $V_{SS} = AV_{SS} = 0\text{ V}$ )

Parameter	Symbol	Pin	Condition	Value		Unit	Remarks
				Min	Max		
Power on rise time	$t_R$	$V_{CC}$	—	0.05	30	ms	
Power off time	$t_{OFF}$	$V_{CC}$	—	1	—	ms	Due to repetitive operation

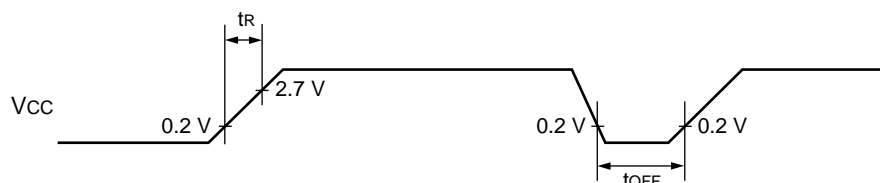

If you change the power supply voltage too rapidly, a power on reset may occur. We recommend that you start up smoothly by restraining voltages when changing the power supply voltage during operation, as shown in the figure below. Perform while not using the PLL clock. However, if voltage drops are within 1 V/s, you can operate while using the PLL clock.

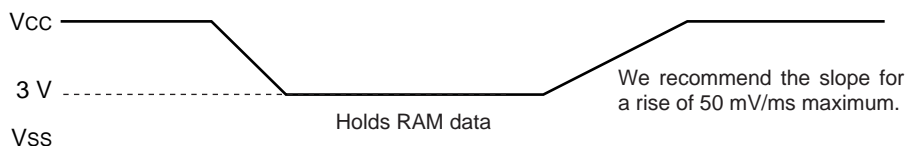

## (4) Clock Output Timing

( $T_A = -40\text{ }^\circ\text{C}$  to  $+105\text{ }^\circ\text{C}$ ,  $V_{CC} = 5.0\text{ V} \pm 10\%$ ,  $V_{SS} = 0.0\text{ V}$ ,  $f_{CP} \leq 24\text{ MHz}$ )

Parameter	Symbol	Pin	Condition	Value		Unit	Remarks
				Min	Max		
Cycle time	$t_{CYC}$	CLK	—	62.5	—	ns	$f_{CP} = 16\text{ MHz}$
				41.76	—	ns	$f_{CP} = 24\text{ MHz}$
CLK $\uparrow \rightarrow$ CLK $\downarrow$	$t_{CHCL}$	CLK	—	20	—	ns	$f_{CP} = 16\text{ MHz}$
				13	—	ns	$f_{CP} = 24\text{ MHz}$

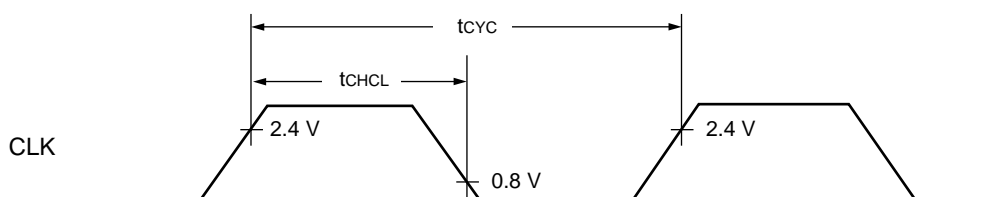

## (5) Bus Timing (Read)

( $T_A = -40^\circ\text{C}$  to  $+105^\circ\text{C}$ ,  $V_{CC} = 5.0\text{ V} \pm 10\%$ ,  $V_{SS} = 0.0\text{ V}$ ,  $f_{CP} \leq 24\text{ MHz}$ )

Parameter	Symbol	Pin	Condition	Value		Unit	Remarks
				Min	Max		
ALE pulse width	$t_{LHLL}$	ALE	—	$t_{CP}/2 - 10$	—	ns	
Valid address $\Rightarrow$ ALE $\downarrow$ time	$t_{AVLL}$	ALE, A21 to A16, AD15 to AD00		$t_{CP}/2 - 20$	—	ns	
ALE $\downarrow \Rightarrow$ Address valid time	$t_{LLAX}$	ALE, AD15 to AD00		$t_{CP}/2 - 15$	—	ns	
Valid address $\Rightarrow \overline{RD} \downarrow$ time	$t_{AVRL}$	A21 to A16, AD15 to AD00, $\overline{RD}$		$t_{CP} - 15$	—	ns	
Valid address $\Rightarrow$ Valid data input	$t_{AVDV}$	A21 to A16, AD15 to AD00		—	$5 t_{CP}/2 - 60$	ns	
$\overline{RD}$ pulse width	$t_{RLRH}$	$\overline{RD}$		$(n^*+3/2) t_{CP} - 20$	—	ns	
$\overline{RD} \downarrow \Rightarrow$ Valid data input	$t_{RLDV}$	$\overline{RD}$ , AD15 to AD00		—	$(n^*+3/2) t_{CP} - 50$	ns	
$\overline{RD} \uparrow \Rightarrow$ Data hold time	$t_{RHDX}$	$\overline{RD}$ , AD15 to AD00		0	—	ns	
$\overline{RD} \uparrow \Rightarrow$ ALE $\uparrow$ time	$t_{RHLH}$	$\overline{RD}$ , ALE		$t_{CP}/2 - 15$	—	ns	
$\overline{RD} \uparrow \Rightarrow$ Address valid time	$t_{RHAX}$	$\overline{RD}$ , A21 to A16		$t_{CP}/2 - 10$	—	ns	
Valid address $\Rightarrow$ CLK $\uparrow$ time	$t_{AVCH}$	A21 to A16, AD15 to AD00, CLK		$t_{CP}/2 - 16$	—	ns	
$\overline{RD} \downarrow \Rightarrow$ CLK $\uparrow$ time	$t_{RLCH}$	$\overline{RD}$ , CLK		$t_{CP}/2 - 15$	—	ns	
ALE $\downarrow \Rightarrow \overline{RD} \downarrow$ time	$t_{LLRL}$	ALE, $\overline{RD}$		$t_{CP}/2 - 15$	—	ns	

\* : n: number of ready cycles

# MB90350 Series

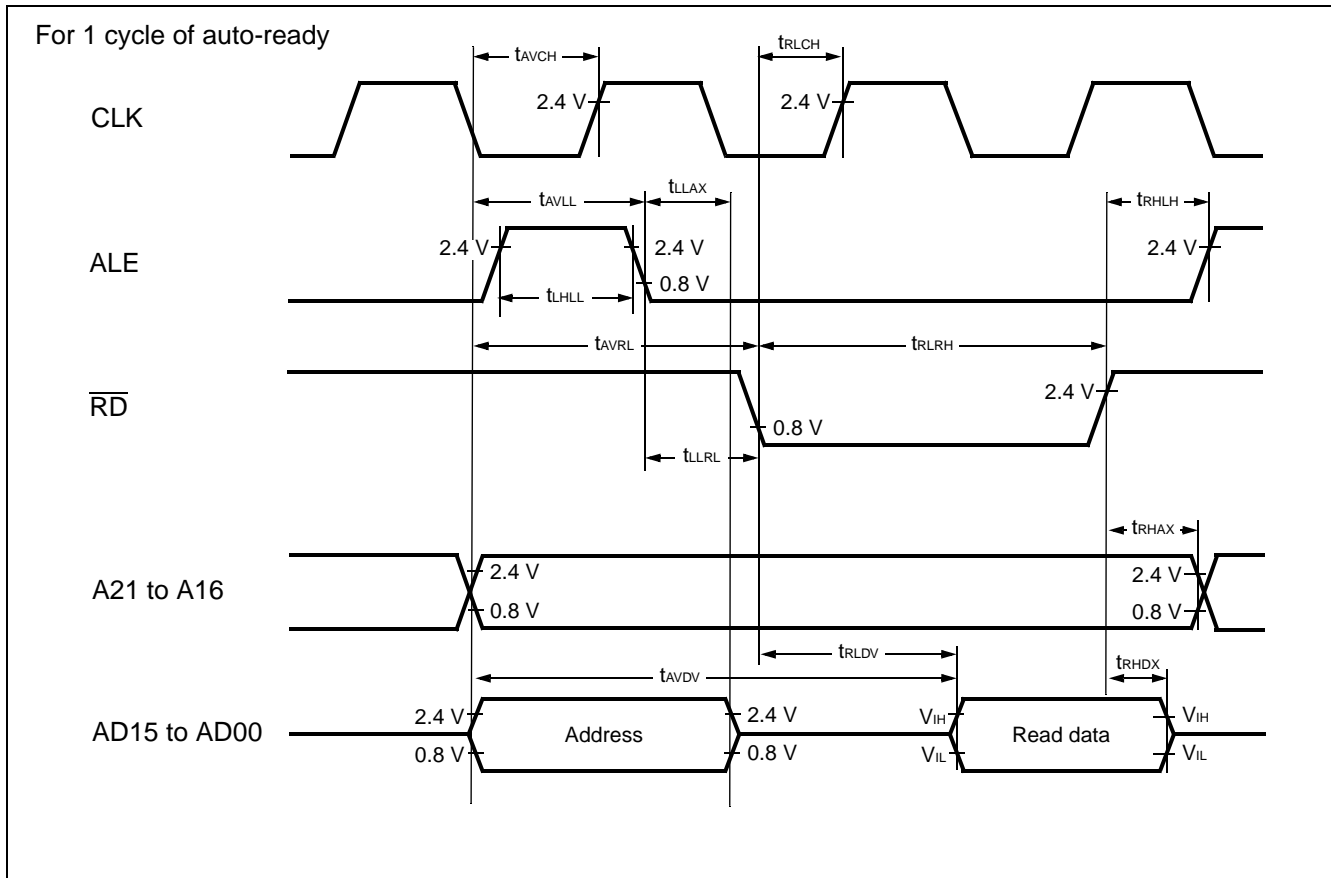

## (6) Bus Timing (Write)

( $T_A = -40^\circ\text{C}$  to  $+105^\circ\text{C}$ ,  $V_{CC} = 5.0\text{ V} \pm 10\%$ ,  $V_{SS} = 0.0\text{ V}$ ,  $f_{CP} \leq 24\text{ MHz}$ )

Parameter	Symbol	Pin	Condition	Value		Unit	Remarks
				Min	Max		
Valid address $\Rightarrow \overline{WR} \downarrow$ time	$t_{AVWL}$	A21 to A16, AD15 to AD00, $\overline{WR}$	—	$t_{CP} - 15$	—	ns	
$\overline{WR}$ pulse width	$t_{WLWH}$	$\overline{WR}$		$(n^* + 3/2)t_{CP} - 20$	—	ns	
Valid data output $\Rightarrow \overline{WR} \uparrow$ time	$t_{DVWH}$	AD15 to AD00, $\overline{WR}$		$(n^* + 3/2)t_{CP} - 20$	—	ns	
$\overline{WR} \uparrow \Rightarrow$ Data hold time	$t_{WHDX}$	AD15 to AD00, $\overline{WR}$		15	—	ns	
$\overline{WR} \uparrow \Rightarrow$ Address valid time	$t_{WHAX}$	A21 to A16, $\overline{WR}$		$t_{CP}/2 - 10$	—	ns	
$\overline{WR} \uparrow \Rightarrow$ ALE $\uparrow$ time	$t_{WHLH}$	$\overline{WR}$ , ALE		$t_{CP}/2 - 15$	—	ns	
$\overline{WR} \downarrow \Rightarrow$ CLK $\uparrow$ time	$t_{WLCH}$	$\overline{WR}$ , CLK		$t_{CP}/2 - 15$	—	ns	

\* : n: Number of ready cycles

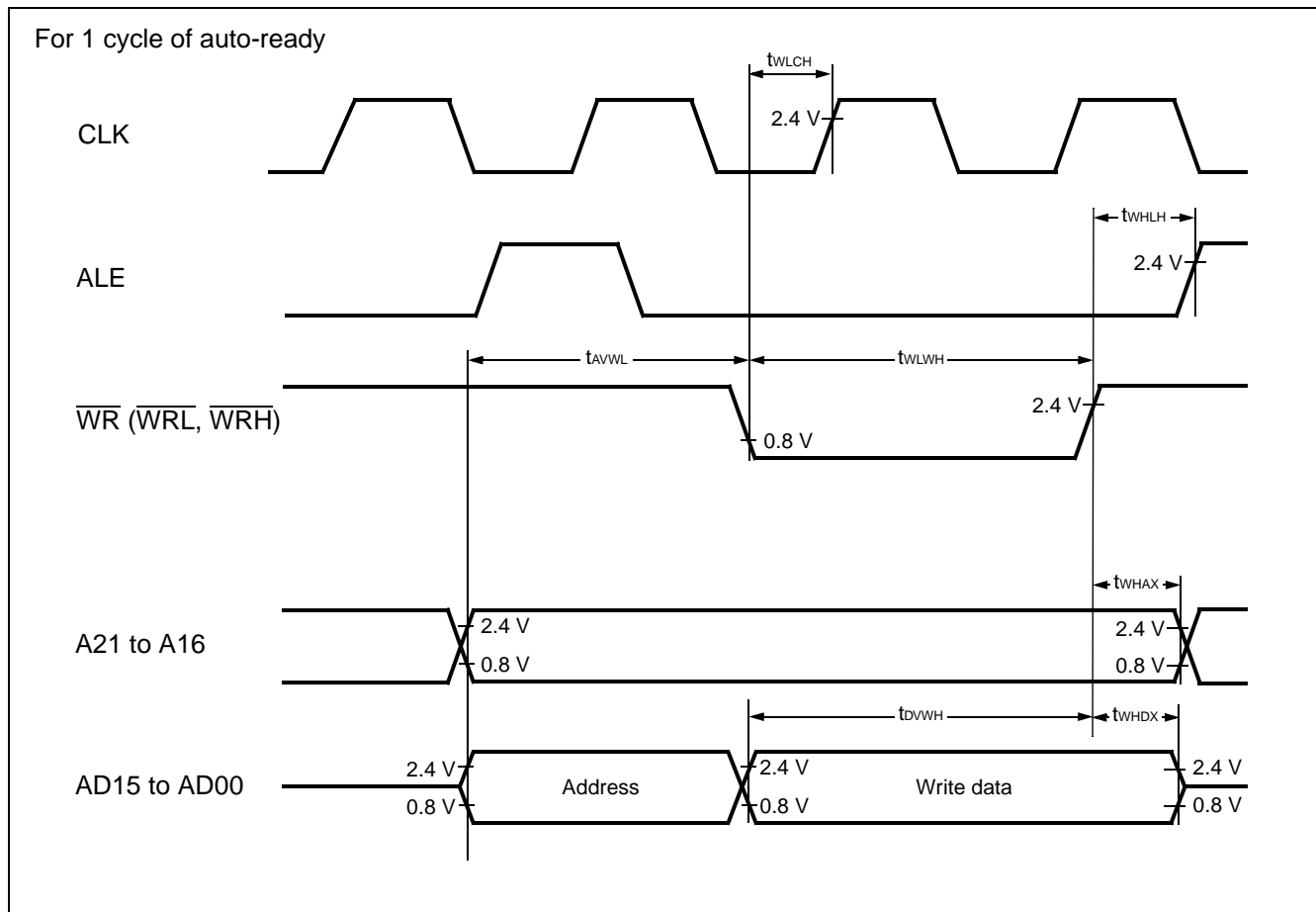

# MB90350 Series

## (7) Ready Input Timing

( $T_A = -40^\circ\text{C}$  to  $+105^\circ\text{C}$ ,  $V_{CC} = 5.0\text{ V} \pm 10\%$ ,  $V_{SS} = 0.0\text{ V}$ ,  $f_{CP} \leq 24\text{ MHz}$ )

Parameter	Symbol	Pin	Condition	Value		Units	Remarks
				Min	Max		
RDY set-up time	$t_{RYHS}$	RDY	—	45	—	ns	$f_{CP} = 16\text{ MHz}$
				32	—	ns	$f_{CP} = 24\text{ MHz}$
RDY hold time	$t_{RYHH}$	RDY		0	—	ns	

Note : If the RDY set-up time is insufficient, use the auto-ready function.

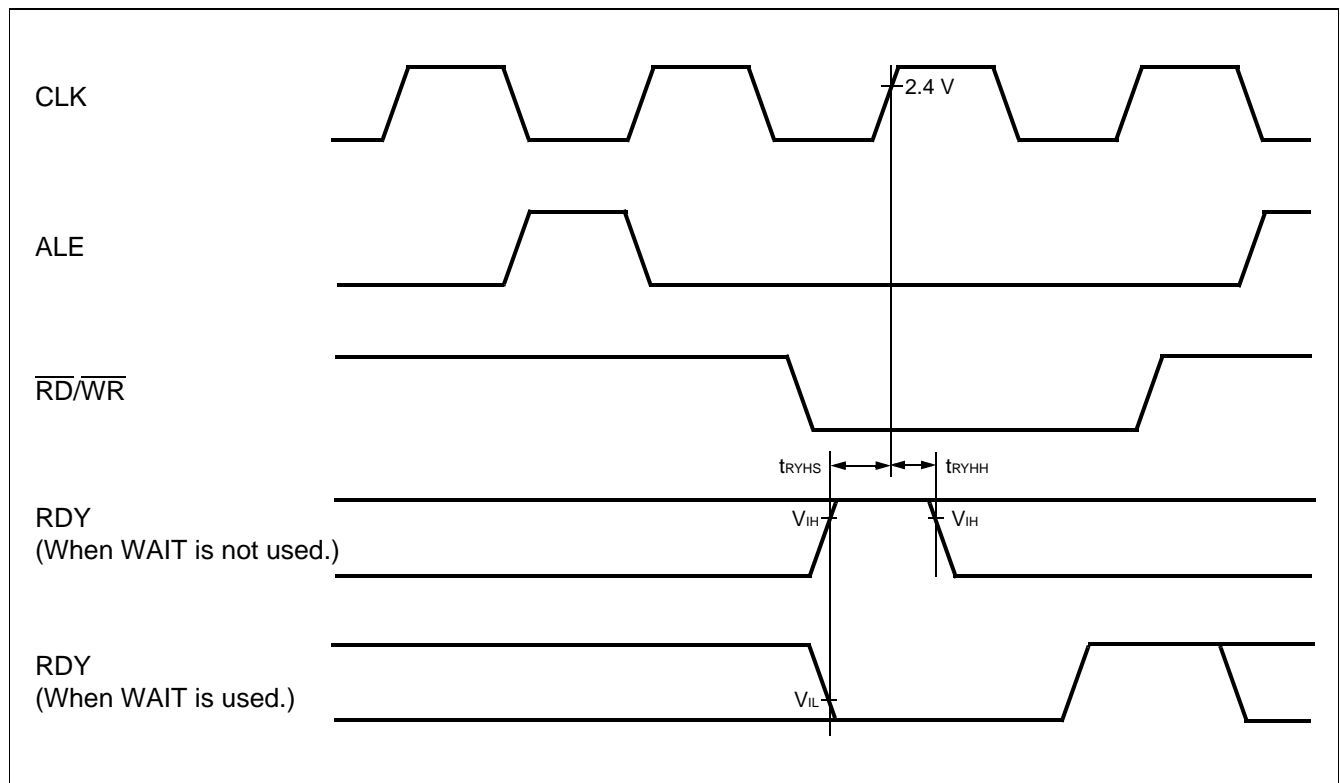

## (8) Hold Timing

( $T_A = -40^{\circ}\text{C}$  to  $+105^{\circ}\text{C}$ ,  $V_{CC} = 5.0\text{ V} \pm 10\%$ ,  $V_{SS} = 0.0\text{ V}$ ,  $f_{CP} \leq 24\text{ MHz}$ )

Parameter	Symbol	Pin	Condition	Value		Units	Remarks
				Min	Max		
Pin floating $\Rightarrow \overline{\text{HAK}} \downarrow$ time	$t_{\text{XHAL}}$	$\overline{\text{HAK}}$	—	30	$t_{\text{CP}}$	ns	
$\overline{\text{HAK}} \uparrow$ time $\Rightarrow$ Pin valid time	$t_{\text{HAHV}}$	$\overline{\text{HAK}}$		$t_{\text{CP}}$	$2 t_{\text{CP}}$	ns	

Note : There is more than 1 machine cycle from when HRQ pin reads in until the  $\overline{\text{HAK}}$  is changed.

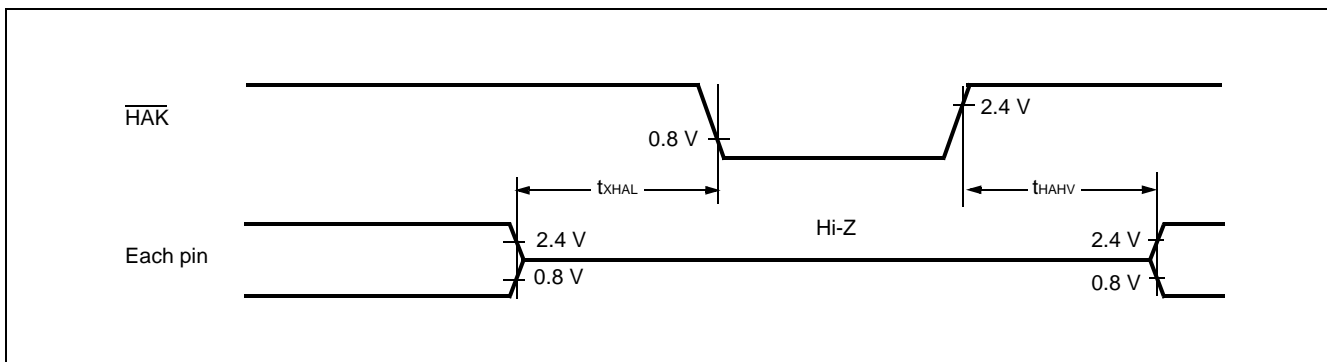

# MB90350 Series

## (9) UART 2/3

(MB90F352(S)/MB90F351(S):  $T_A = -40\text{ }^\circ\text{C}$  to  $+105\text{ }^\circ\text{C}$ ,  $V_{CC} = 5.0\text{ V} \pm 10\%$ ,  $f_{CP} \leq 24\text{ MHz}$ ,  $V_{SS} = AV_{SS} = 0\text{ V}$ )

(MB90F352(S)/MB90F351(S):  $T_A = -40\text{ }^\circ\text{C}$  to  $+125\text{ }^\circ\text{C}$ ,  $V_{CC} = 5.0\text{ V} \pm 10\%$ ,  $f_{CP} \leq 16\text{ MHz}$ ,  $V_{SS} = AV_{SS} = 0\text{ V}$ )

(Device other than above:  $T_A = -40\text{ }^\circ\text{C}$  to  $+125\text{ }^\circ\text{C}$ ,  $V_{CC} = 5.0\text{ V} \pm 10\%$ ,  $f_{CP} \leq 24\text{ MHz}$ ,  $V_{SS} = AV_{SS} = 0\text{ V}$ )

Parameter	Symbol	Pin	Condition	Value		Unit	Remarks
				Min	Max		
Serial clock cycle time	$t_{SCYC}$	SCK2, SCK3	Internal shift clock mode output pins are $C_L = 80\text{ pF} + 1\text{ TTL}$	$8\ t_{CP}^*$	—	ns	
SCK ↓ → SOT delay time	$t_{SLOV}$	SCK2, SCK3, SOT2, SOT3		-80	+80	ns	
Valid SIN → SCK ↑	$t_{IVSH}$	SCK2, SCK3, SIN2, SIN3		100	—	ns	
SCK ↑ → Valid SIN hold time	$t_{SHIX}$	SCK2, SCK3, SIN2, SIN3		60	—	ns	
Serial clock "H" pulse width	$t_{SHSL}$	SCK2, SCK3	External shift clock mode output pins are $C_L = 80\text{ pF} + 1\text{ TTL}$	$4\ t_{CP}$	—	ns	
Serial clock "L" pulse width	$t_{LSLH}$	SCK2, SCK3		$4\ t_{CP}$	—	ns	
SCK ↓ → SOT delay time	$t_{SLOV}$	SCK2, SCK3, SOT2, SOT3		—	150	ns	
Valid SIN → SCK ↑	$t_{IVSH}$	SCK2, SCK3, SIN2, SIN3		60	—	ns	
SCK ↑ → Valid SIN hold time	$t_{SHIX}$	SCK2, SCK3, SIN2, SIN3		60	—	ns	

\* : Refer to " (1) Clock timing" rating for  $t_{CP}$  (internal operating clock cycle time).

- Notes :
- AC characteristic in CLK synchronized mode.
  - $C_L$  is load capacity value of pins when testing.

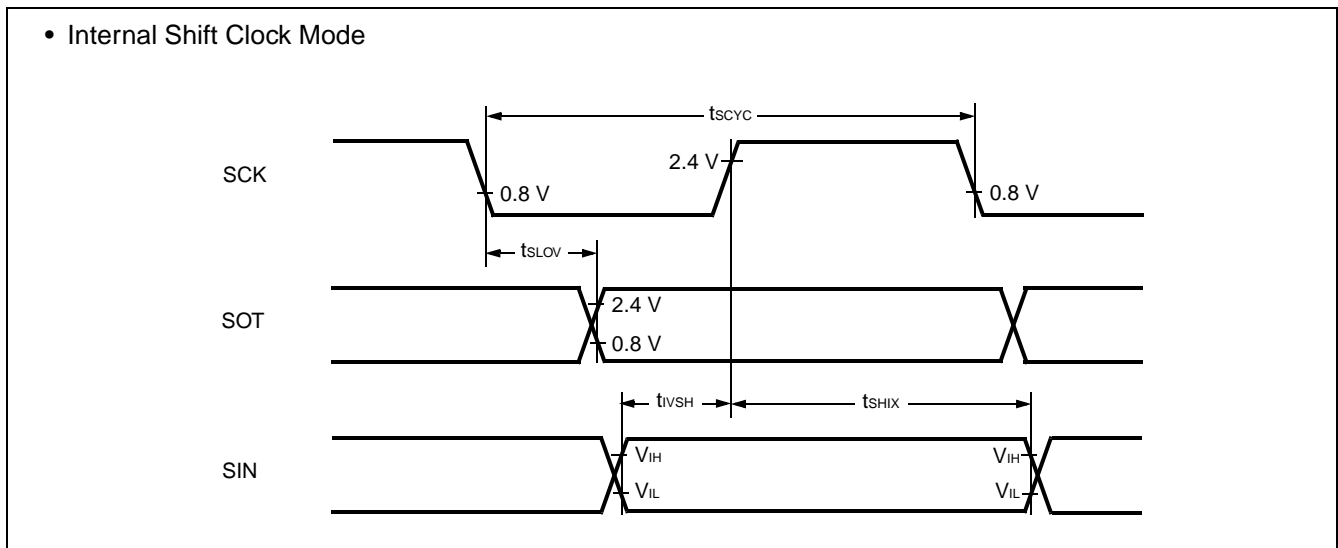

• External Shift Clock Mode

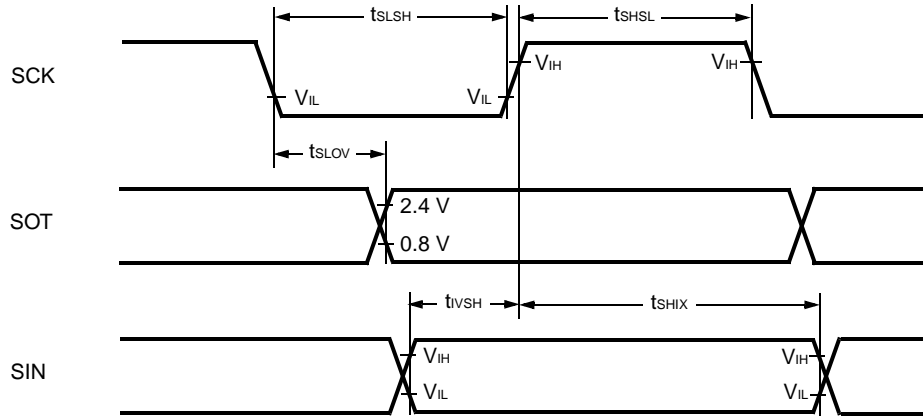

## (10) Trigger Input Timing

(MB90F352(S)/MB90F351(S):  $T_A = -40\text{ }^\circ\text{C}$  to  $+105\text{ }^\circ\text{C}$ ,  $V_{CC} = 5.0\text{ V} \pm 10\%$ ,  $f_{CP} \leq 24\text{ MHz}$ ,  $V_{SS} = AV_{SS} = 0\text{ V}$ )

(MB90F352(S)/MB90F351(S):  $T_A = -40\text{ }^\circ\text{C}$  to  $+125\text{ }^\circ\text{C}$ ,  $V_{CC} = 5.0\text{ V} \pm 10\%$ ,  $f_{CP} \leq 16\text{ MHz}$ ,  $V_{SS} = AV_{SS} = 0\text{ V}$ )

(Device other than above:  $T_A = -40\text{ }^\circ\text{C}$  to  $+125\text{ }^\circ\text{C}$ ,  $V_{CC} = 5.0\text{ V} \pm 10\%$ ,  $f_{CP} \leq 24\text{ MHz}$ ,  $V_{SS} = AV_{SS} = 0\text{ V}$ )

Parameter	Symbol	Pin	Condition	Value		Unit	Remarks
				Min	Max		
Input pulse width	$t_{TRGH}$ $t_{TRGL}$	INT8 to INT15, INT9R to INT11R, ADTG	—	$5 t_{CP}$	—	ns	

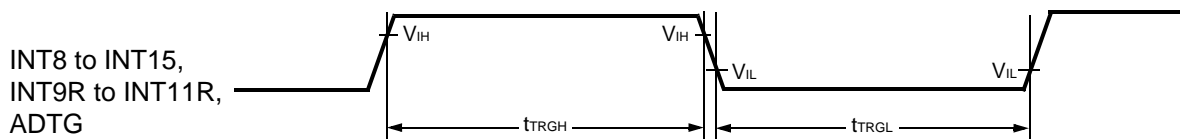

# MB90350 Series

## (11) Timer Related Resource Input Timing

(MB90F352(S)/MB90F351(S):  $T_A = -40\text{ }^\circ\text{C}$  to  $+105\text{ }^\circ\text{C}$ ,  $V_{CC} = 5.0\text{ V} \pm 10\%$ ,  $f_{CP} \leq 24\text{ MHz}$ ,  $V_{SS} = AV_{SS} = 0\text{ V}$ )

(MB90F352(S)/MB90F351(S):  $T_A = -40\text{ }^\circ\text{C}$  to  $+125\text{ }^\circ\text{C}$ ,  $V_{CC} = 5.0\text{ V} \pm 10\%$ ,  $f_{CP} \leq 16\text{ MHz}$ ,  $V_{SS} = AV_{SS} = 0\text{ V}$ )

(Device other than above:  $T_A = -40\text{ }^\circ\text{C}$  to  $+125\text{ }^\circ\text{C}$ ,  $V_{CC} = 5.0\text{ V} \pm 10\%$ ,  $f_{CP} \leq 24\text{ MHz}$ ,  $V_{SS} = AV_{SS} = 0\text{ V}$ )

Parameter	Symbol	Pin	Condition	Value		Unit	Remarks
				Min	Max		
Input pulse width	$t_{TIWH}$	TIN1, TIN3, IN0, IN1, IN4 to IN7	—	4 $t_{CP}$	—	ns	
	$t_{TIWL}$						

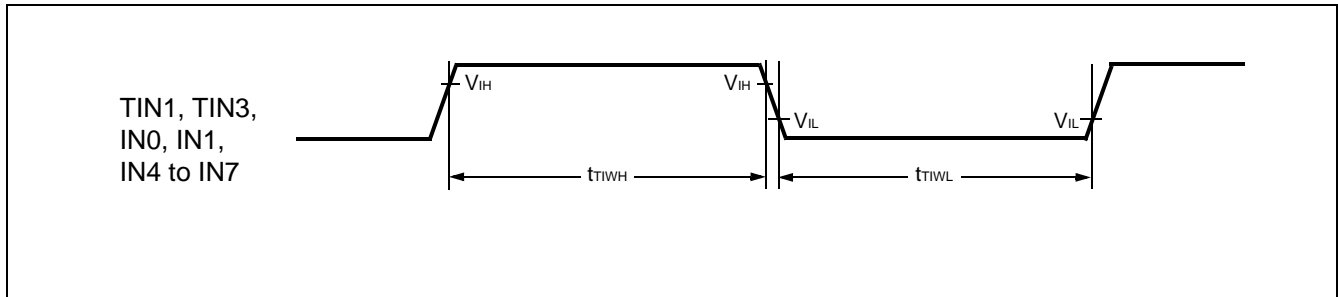

## (12) Timer Related Resource Output Timing

(MB90F352(S)/MB90F351(S):  $T_A = -40\text{ }^\circ\text{C}$  to  $+105\text{ }^\circ\text{C}$ ,  $V_{CC} = 5.0\text{ V} \pm 10\%$ ,  $f_{CP} \leq 24\text{ MHz}$ ,  $V_{SS} = AV_{SS} = 0\text{ V}$ )

(MB90F352(S)/MB90F351(S):  $T_A = -40\text{ }^\circ\text{C}$  to  $+125\text{ }^\circ\text{C}$ ,  $V_{CC} = 5.0\text{ V} \pm 10\%$ ,  $f_{CP} \leq 16\text{ MHz}$ ,  $V_{SS} = AV_{SS} = 0\text{ V}$ )

(Device other than above:  $T_A = -40\text{ }^\circ\text{C}$  to  $+125\text{ }^\circ\text{C}$ ,  $V_{CC} = 5.0\text{ V} \pm 10\%$ ,  $f_{CP} \leq 24\text{ MHz}$ ,  $V_{SS} = AV_{SS} = 0\text{ V}$ )

Parameter	Symbol	Pin	Condition	Value		Unit	Remarks
				Min	Max		
CLK $\uparrow$ $\Rightarrow$ $T_{OUT}$ change time	$t_{TO}$	TOT1, TOT3, PPG4, PPG6, PPG8 to PPGF	—	30	—	ns	

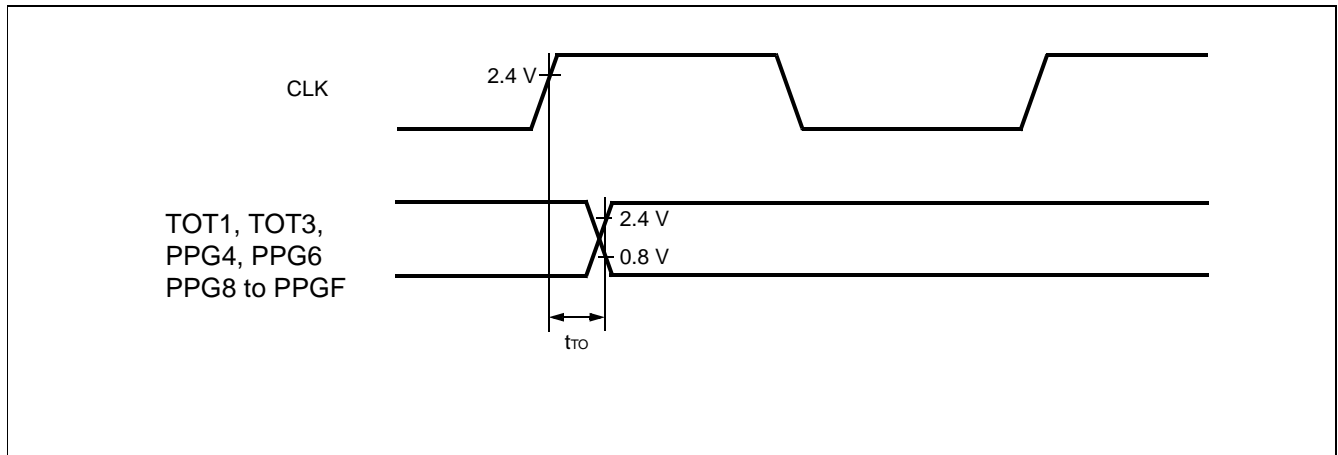

## (13) I<sup>2</sup>C Timing

(MB90F352(S)/MB90F351(S):  $T_A = -40\text{ }^\circ\text{C}$  to  $+105\text{ }^\circ\text{C}$ ,  $V_{CC} = AV_{CC} = 5.0\text{ V} \pm 10\%$ ,  $f_{CP} \leq 24\text{ MHz}$ ,  $V_{SS} = AV_{SS} = 0\text{ V}$ )

(MB90F352(S)/MB90F351(S):  $T_A = -40\text{ }^\circ\text{C}$  to  $+125\text{ }^\circ\text{C}$ ,  $V_{CC} = AV_{CC} = 5.0\text{ V} \pm 10\%$ ,  $f_{CP} \leq 16\text{ MHz}$ ,  $V_{SS} = AV_{SS} = 0\text{ V}$ )

(Device other than above:  $T_A = -40\text{ }^\circ\text{C}$  to  $+125\text{ }^\circ\text{C}$ ,  $V_{CC} = AV_{CC} = 5.0\text{ V} \pm 10\%$ ,  $f_{CP} \leq 24\text{ MHz}$ ,  $V_{SS} = AV_{SS} = 0\text{ V}$ )

Parameter	Symbol	Condition	Standard-mode		Fast-mode*4		Unit
			Min	Max	Min	Max	
SCL clock frequency	$f_{SCL}$	R = 1.7 k $\Omega$ , C = 50 pF*1	0	100	0	400	kHz
Hold time for (repeated) START condition SDA $\downarrow$ →SCL $\downarrow$	$t_{HDSTA}$		4.0	—	0.6	—	$\mu\text{s}$
“L” width of the SCL clock	$t_{LOW}$		4.7	—	1.3	—	$\mu\text{s}$
“H” width of the SCL clock	$t_{HIGH}$		4.0	—	0.6	—	$\mu\text{s}$
Set-up time for a repeated START condition SCL $\uparrow$ →SDA $\downarrow$	$t_{SUSTA}$		4.7	—	0.6	—	$\mu\text{s}$
Data hold time SCL $\downarrow$ →SDA $\downarrow$ ↑	$t_{HDDAT}$		0	3.45*2	0	0.9*3	$\mu\text{s}$
Data set-up time SDA $\downarrow$ ↑→SCL $\uparrow$	$t_{SUDAT}$		250*5	—	100*5	—	ns
Set-up time for STOP condition SCL $\uparrow$ →SDA $\uparrow$	$t_{SUSTO}$		4.0	—	0.6	—	$\mu\text{s}$
Bus free time between STOP condition and START condition	$t_{BUS}$		4.7	—	1.3	—	$\mu\text{s}$

\*1 : R,C : Pull-up resistor and load capacitor of the SCL and SDA lines.

\*2 : The maximum  $t_{HDDAT}$  has only to be met if the device does not stretch the “L” width ( $t_{LOW}$ ) of the SCL signal.

\*3 : A Fast-mode I<sup>2</sup>C -bus device can be used in a Standard-mode I<sup>2</sup>C-bus system, but the requirement  $t_{SUDAT} \geq 250\text{ ns}$  must then be met.

\*4 : For use at over 100 kHz, set the machine clock to at least 6 MHz.

\*5 : Refer to “• Note of SDA, SCL set-up time”.

### • Note of SDA, SCL set-up time

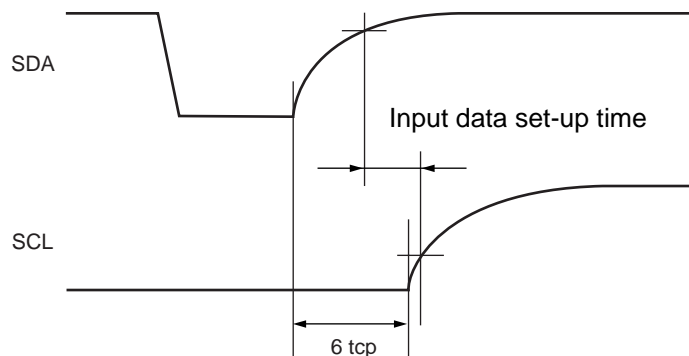

# MB90350 Series

Note : The rating of the input data set-up time in the device connected to the bus cannot be satisfied depending on the load capacitance or pull-up resistor.  
Be sure to adjust the pull-up resistor of SDA and SCL if the rating of the input data set-up time cannot be satisfied.

- Timing definition

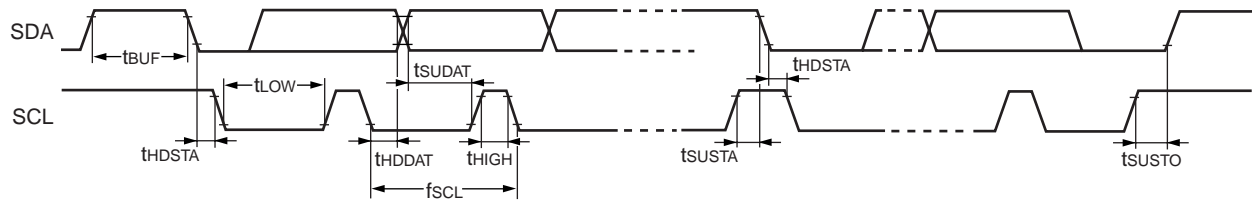

## 5. A/D Converter

(MB90F352(S)/MB90F351(S):  $T_A = -40\text{ }^\circ\text{C}$  to  $+105\text{ }^\circ\text{C}$ ,  $3.0\text{ V} \leq \text{AVRH}$ ,  $V_{CC} = \text{AV}_{CC} = 5.0\text{ V} \pm 10\%$ ,  $f_{CP} \leq 24\text{ MHz}$ ,  $V_{SS} = \text{AV}_{SS} = 0\text{ V}$ )

(MB90F352(S)/MB90F351(S):  $T_A = -40\text{ }^\circ\text{C}$  to  $+125\text{ }^\circ\text{C}$ ,  $3.0\text{ V} \leq \text{AVRH}$ ,  $V_{CC} = \text{AV}_{CC} = 5.0\text{ V} \pm 10\%$ ,  $f_{CP} \leq 16\text{ MHz}$ ,  $V_{SS} = \text{AV}_{SS} = 0\text{ V}$ )

(Device other than above:  $T_A = -40\text{ }^\circ\text{C}$  to  $+125\text{ }^\circ\text{C}$ ,  $3.0\text{ V} \leq \text{AVRH}$ ,  $V_{CC} = \text{AV}_{CC} = 5.0\text{ V} \pm 10\%$ ,  $f_{CP} \leq 24\text{ MHz}$ ,  $V_{SS} = \text{AV}_{SS} = 0\text{ V}$ )

Parameter	Symbol	Pin	Value			Unit	Remarks
			Min	Typ	Max		
Resolution	—	—	—	—	10	bit	
Total error	—	—	—	—	$\pm 3.0$	LSB	
Nonlinearity error	—	—	—	—	$\pm 2.5$	LSB	
Differential nonlinearity error	—	—	—	—	$\pm 1.9$	LSB	
Zero reading voltage	$V_{OT}$	AN0 to AN14	$\text{AV}_{SS} - 1.5$	$\text{AV}_{SS} + 0.5$	$\text{AV}_{SS} + 2.5$	LSB	
Full scale reading voltage	$V_{FST}$	AN0 to AN14	$\text{AVRH} - 3.5$	$\text{AVRH} - 1.5$	$\text{AVRH} + 0.5$	LSB	
Compare time	—	—	1.0	—	16,500	$\mu\text{s}$	$4.5\text{ V} \leq \text{AV}_{CC} \leq 5.5\text{ V}$
			2.0				$4.0\text{ V} \leq \text{AV}_{CC} < 4.5\text{ V}$
Sampling time	—	—	0.5	—	$\infty$	$\mu\text{s}$	$4.5\text{ V} \leq \text{AV}_{CC} \leq 5.5\text{ V}$
			1.2				$4.0\text{ V} \leq \text{AV}_{CC} < 4.5\text{ V}$
Analog port input current	$I_{AIN}$	AN0 to AN14	-0.3	—	+0.3	$\mu\text{A}$	
Analog input voltage range	$V_{AIN}$	AN0 to AN14	$\text{AV}_{SS}$	—	$\text{AVRH}$	V	
Reference voltage range	—	AVRH	$\text{AV}_{SS} + 2.7$	—	$\text{AV}_{CC}$	V	
Power supply current	$I_A$	$\text{AV}_{CC}$	—	3.5	7.5	mA	
	$I_{AH}$	$\text{AV}_{CC}$	—	—	5	$\mu\text{A}$	*
Reference voltage supply current	$I_R$	AVRH	—	600	900	$\mu\text{A}$	
	$I_{RH}$	AVRH	—	—	5	$\mu\text{A}$	*
Offset between input channels	—	AN0 to AN14	—	—	4	LSB	

\* : If A/D converter is not operating, a current when CPU is stopped is applicable ( $V_{CC} = \text{AV}_{CC} = \text{AVRH} = 5.0\text{ V}$ ) .

# MB90350 Series

## Notes on A/D Converter Section

### • About the external impedance of the analog input and its sampling time

A/D converter with sample and hold circuit. If the external impedance is too high to keep sufficient sampling time, the analog voltage charged to the internal sample and hold capacitor is insufficient, adversely affecting A/D conversion precision. Therefore to satisfy the A/D conversion precision standard, consider the relationship between the external impedance and minimum sampling time and either adjust the register value and operating frequency or decrease the external impedance so that the sampling time is longer than the minimum value. Also if the sampling time cannot be sufficient, connect a capacitor of about 0.1  $\mu\text{F}$  to the analog input pin.

• Analog input equivalence circuit

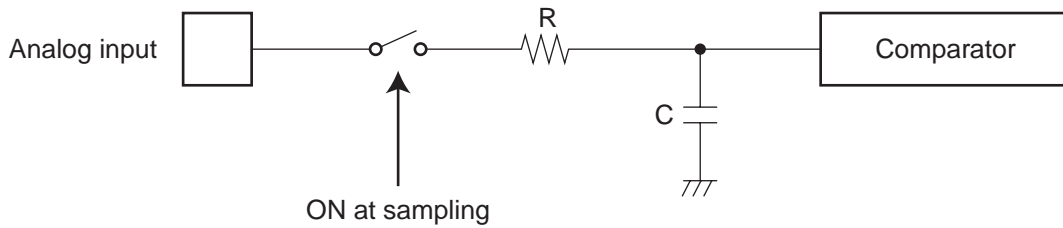

MB90F352(S), MB90F351A(S), MB90F352A(S), MB90F351TA(S), MB90F352TA(S),  
 MB90F356A(S), MB90F357A(S), MB90F356TA(S), MB90F357TA(S),

	R	C
$4.5\text{ V} \leq AV_{CC} \leq 5.5\text{ V}$	2.0 k $\Omega$ (Max)	16.0 pF (Max)
$4.0\text{ V} \leq AV_{CC} \leq 4.5\text{ V}$	8.2 k $\Omega$ (Max)	16.0 pF (Max)

MB90V340A-101/102/103/104, MB90351A(S), MB90352A(S), MB90351TA(S), MB90352TA(S),  
 MB90356A(S), MB90357A(S), MB90356TA(S), MB90357TA(S),

	R	C
$4.5\text{ V} \leq AV_{CC} \leq 5.5\text{ V}$	2.0 k $\Omega$ (Max)	14.4 pF (Max)
$4.0\text{ V} \leq AV_{CC} \leq 4.5\text{ V}$	8.2 k $\Omega$ (Max)	14.4 pF (Max)

Note : The value is reference value.

- Flash memory device

· Relation between External impedance and minimum sampling time

(MB90F352(S), MB90F351A(S), MB90F352A(S), MB90F351TA(S), MB90F352TA(S), MB90F356A(S), MB90F357A(S), MB90F356TA(S), MB90F357TA(S))

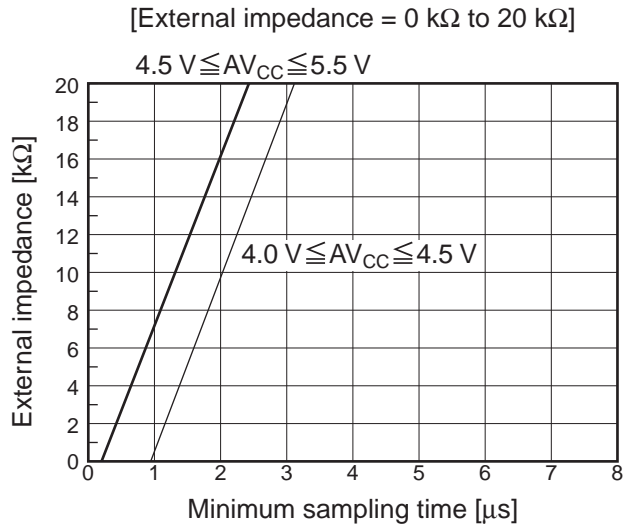
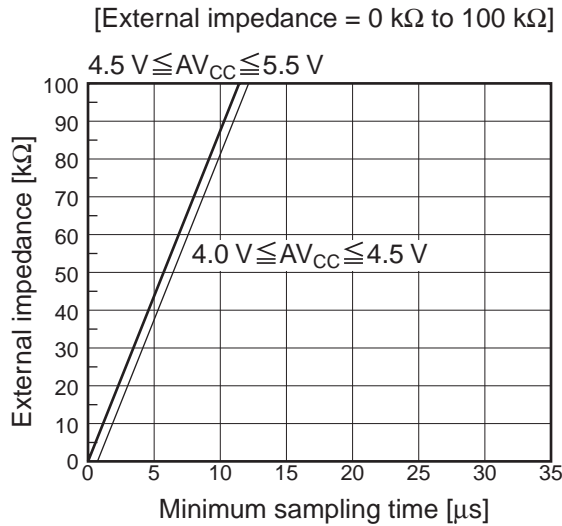

- MASK ROM device

· Relation between External impedance and minimum sampling time

(MB90V340A-101/102/103/104, MB90351A(S), MB90352A(S), MB90351TA(S), MB90352TA(S), MB90356A(S), MB90357A(S), MB90356TA(S), MB90357TA(S))

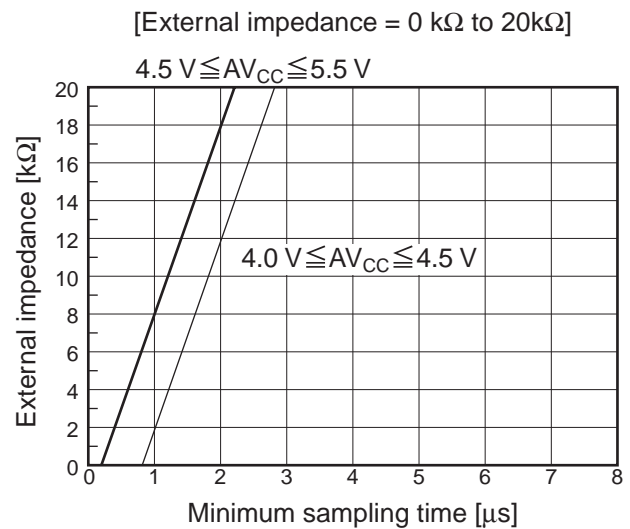
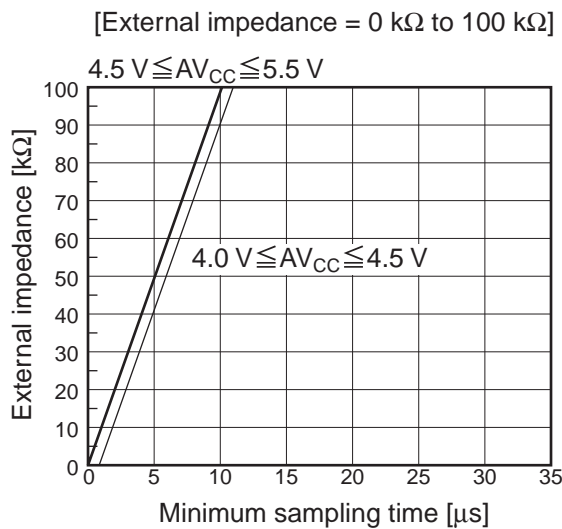

- About the error

Values of relative errors grow larger, as  $|AV_{RH} - AV_{SS}|$  becomes smaller.

## 6. Definition of A/D Converter Terms

- Resolution : Analog variation that is recognized by an A/D converter.
- Non linearity error : Deviation between a line across zero-transition line ( "00 0000 0000" ← → "00 0000 0001" ) and full-scale transition line ( "11 1111 1110" ← → "11 1111 1111" ) and actual conversion characteristics.
- Differential linearity error : Deviation of input voltage, which is required for changing output code by 1 LSB, from an ideal value.
- Total error : Difference between an actual value and a theoretical value. A total error includes zero transition error, full-scale transition error, and linear error.

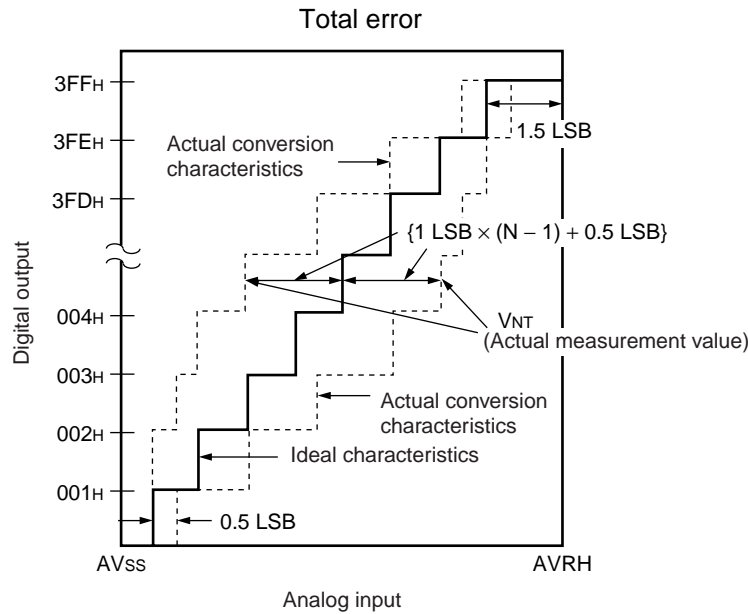

$$\text{Total error of digital output "N"} = \frac{V_{NT} - \{1 \text{ LSB} \times (N - 1) + 0.5 \text{ LSB}\}}{1 \text{ LSB}} \text{ [LSB]}$$

$$1 \text{ LSB} = (\text{Ideal value}) \frac{AVRH - AVSS}{1024} \text{ [V]}$$

N : A/D converter digital output value

$$V_{OT} (\text{Ideal value}) = AVSS + 0.5 \text{ LSB [V]}$$

$$V_{FST} (\text{Ideal value}) = AVRH - 1.5 \text{ LSB [V]}$$

V<sub>NT</sub> : A voltage at which digital output transits from (N - 1) to N.

(Continued)

(Continued)

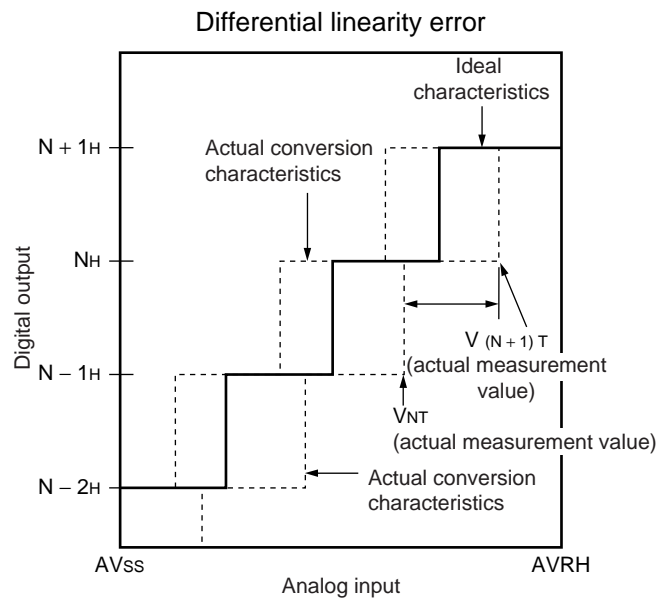
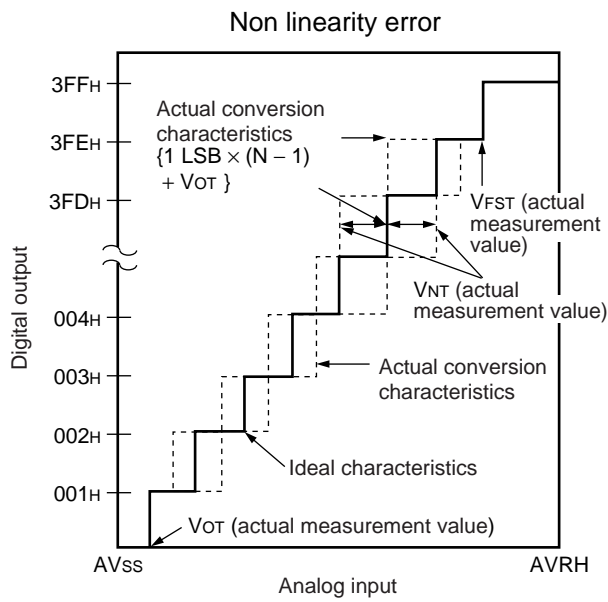

$$\text{Non linearity error of digital output } N = \frac{V_{NT} - \{1 \text{ LSB} \times (N - 1) + V_{OT}\}}{1 \text{ LSB}} \text{ [LSB]}$$

$$\text{Differential linearity error of digital output } N = \frac{V_{(N+1)T} - V_{NT}}{1 \text{ LSB}} - 1 \text{ LSB [LSB]}$$

$$1 \text{ LSB} = \frac{V_{FST} - V_{OT}}{1022} \text{ [V]}$$

N : A/D converter digital output value

$V_{OT}$  : Voltage at which digital output transits from "000H" to "001H."

$V_{FST}$  : Voltage at which digital output transits from "3FEH" to "3FFH."

# MB90350 Series

## 7. Flash Memory Program/Erase Characteristics

### Flash Memory

Parameter	Conditions	Value			Unit	Remarks
		Min	Typ	Max		
Sector erase time	$T_A = +25\text{ }^\circ\text{C}$ $V_{CC} = 5.0\text{ V}$	—	1	15	s	Excludes programming prior to erasure
Chip erase time		—	9	—	s	Excludes programming prior to erasure
Word (16-bit width) programming time		—	16	3,600	$\mu\text{s}$	Except for the overhead time of the system level
Program/Erase cycle	—	10,000	—	—	cycle	
Flash Memory Data Retention Time	Average $T_A = +85\text{ }^\circ\text{C}$	20	—	—	year	*

\* : This value comes from the technology qualification.

(Using Arrhenius equation to translate high temperature measurements into normalized value at +85 °C)

### Dual Operation Flash Memory

Parameter	Conditions	Value			Unit	Remarks
		Min	Typ	Max		
Sector erase time (4 Kbytes sector)	$T_A = +25\text{ }^\circ\text{C}$ $V_{CC} = 5.0\text{ V}$	—	0.2	0.5	s	Excludes programming prior to erasure
Sector erase time (16 Kbytes sector)		—	0.5	7.5	s	Excludes programming prior to erasure
Chip erase time		—	4.6	—	s	Excludes programming prior to erasure
Word (16-bit width) programming time		—	64	3,600	$\mu\text{s}$	Except for the overhead time of the system level
Program/Erase cycle	—	10,000	—	—	cycle	
Flash Memory Data Retention Time	Average $T_A = +85\text{ }^\circ\text{C}$	20	—	—	year	*

\* : This value comes from the technology qualification.

(Using Arrhenius equation to translate high temperature measurements into normalized value at +85 °C)

# MB90350 Series

## ■ ORDERING INFORMATION

Part number	Package	Remarks
MB90F351PFM	64-pin plastic LQFP FPT-64P-M09 12mm □, 0.65mm pitch	Flash memory products (64 Kbytes)
MB90F351SPFM		
MB90F352PFM		Flash memory products (128 Kbytes)
MB90F352SPFM		
MB90F351APMC	64-pin plastic LQFP FPT-64P-M23 12mm □, 0.65mm pitch	Dual operation Flash memory products (64 Kbytes)
MB90F351ASPMC		
MB90F351TAPMC		
MB90F351TASPMC		
MB90F356APMC		
MB90F356ASPMC		
MB90F356TAPMC		
MB90F356TASPMC		
MB90F352APMC	64-pin plastic LQFP FPT-64P-M23 12mm □, 0.65mm pitch	Dual operation Flash memory products (128 Kbytes)
MB90F352ASPMC		
MB90F352TAPMC		
MB90F352TASPMC		
MB90F357APMC		
MB90F357ASPMC		
MB90F357TAPMC		
MB90F357TASPMC		
MB90351APMC	64-pin plastic LQFP FPT-64P-M23 12mm □, 0.65mm pitch	MASK ROM products (64 Kbytes)
MB90351ASPMC		
MB90351TAPMC		
MB90351TASPMC		
MB90356APMC		
MB90356ASPMC		
MB90356TAPMC		
MB90356TASPMC		
MB90352APMC	64-pin plastic LQFP FPT-64P-M23 12mm □, 0.65mm pitch	MASK ROM products (128 Kbytes)
MB90352ASPMC		
MB90352TAPMC		
MB90352TASPMC		
MB90357APMC		
MB90357ASPMC		
MB90357TAPMC		
MB90357TASPMC		

(Continued)

# MB90350 Series

(Continued)

Part number	Package	Remarks
MB90F351APMC1	64-pin plastic LQFP FPT-64P-M24 10 mm □, 0.50 mm pitch	Dual operation Flash memory products* (64 Kbytes)
MB90F351ASPMC1		
MB90F351TAPMC1		
MB90F351TASPMC1		
MB90F356APMC1		
MB90F356ASPMC1		
MB90F356TAPMC1		
MB90F356TASPMC1		
MB90F352APMC1	64-pin plastic LQFP FPT-64P-M24 10 mm □, 0.50 mm pitch	Dual operation Flash memory products* (128 Kbytes)
MB90F352ASPMC1		
MB90F352TAPMC1		
MB90F352TASPMC1		
MB90F357APMC1		
MB90F357ASPMC1		
MB90F357TAPMC1		
MB90F357TASPMC1		
MB90351APMC1	64-pin plastic LQFP FPT-64P-M24 10 mm □, 0.50 mm pitch	MASK ROM products* (64 Kbytes)
MB90351ASPMC1		
MB90351TAPMC1		
MB90351TASPMC1		
MB90356APMC1		
MB90356ASPMC1		
MB90356TAPMC1		
MB90356TASPMC1		
MB90352APMC1	64-pin plastic LQFP FPT-64P-M24 10 mm □, 0.50 mm pitch	MASK ROM products* (128 Kbytes)
MB90352ASPMC1		
MB90352TAPMC1		
MB90352TASPMC1		
MB90357APMC1		
MB90357ASPMC1		
MB90357TAPMC1		
MB90357TASPMC1		
MB90V340A-101	299-pin ceramic PGA PGA-299C-A01	Device for evaluation
MB90V340A-102		
MB90V340A-103		
MB90V340A-104		

\* : These devices are under development.

## ■ PACKAGE DIMENSIONS

64-pin plastic LQFP  
(FPT-64P-M09)

Note 1) \* : These dimensions do not include resin protrusion.  
 Note 2) Pins width and pins thickness include plating thickness.  
 Note 3) Pins width do not include tie bar cutting remainder.

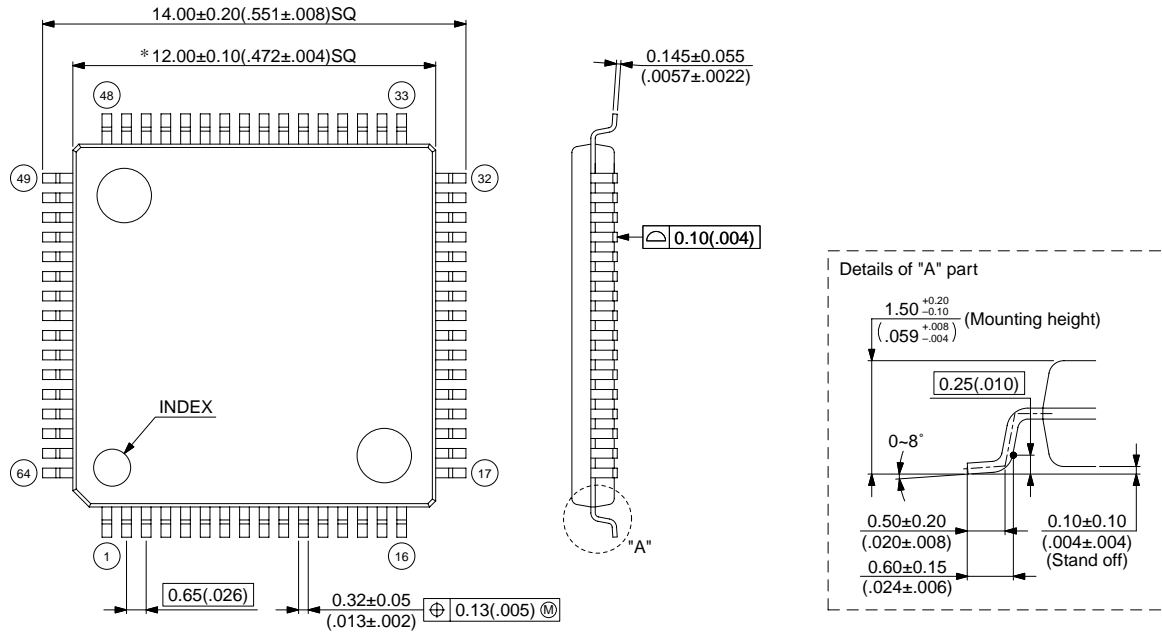

© 2003 FUJITSU LIMITED F64018S-c-3-5

Dimensions in mm (inches) .

Note : The values in parentheses are reference values.

(Continued)

# MB90350 Series

64-pin plastic LQFP  
(FPT-64P-M23)

Note 1) \* : These dimensions do not include resin protrusion.  
 Note 2) Pins width and pins thickness include plating thickness.  
 Note 3) Pins width do not include tie bar cutting remainder.

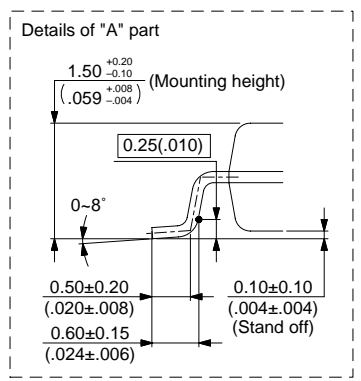
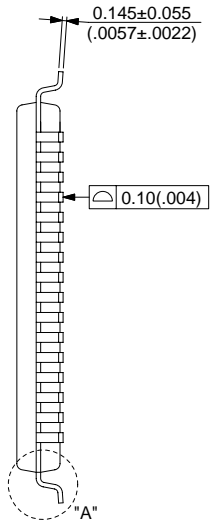
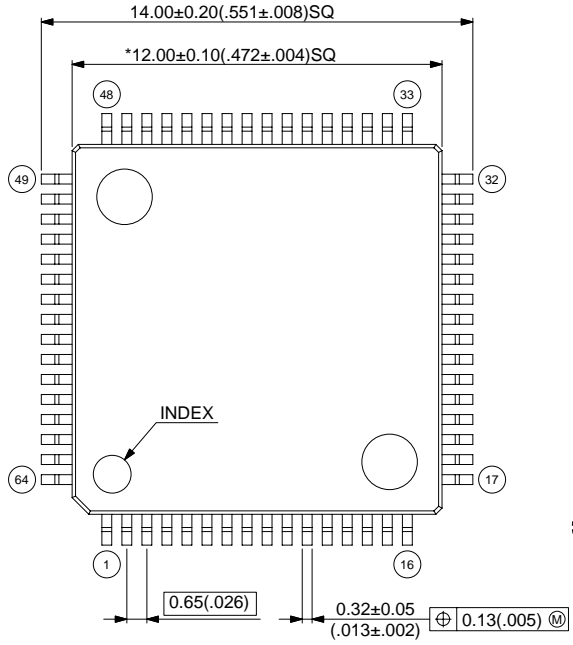

© 2003 FUJITSU LIMITED F64034S-c-1-1

Dimensions in mm (inches) .  
 Note : The values in parentheses are reference values.

(Continued)

# MB90350 Series

(Continued)

64-pin plastic LQFP  
(FPT-64P-M24)

- Note 1) \* : These dimensions do not include resin protrusion.
- Note 2) Pins width and pins thickness include plating thickness.
- Note 3) Pins width do not include tie bar cutting remainder.

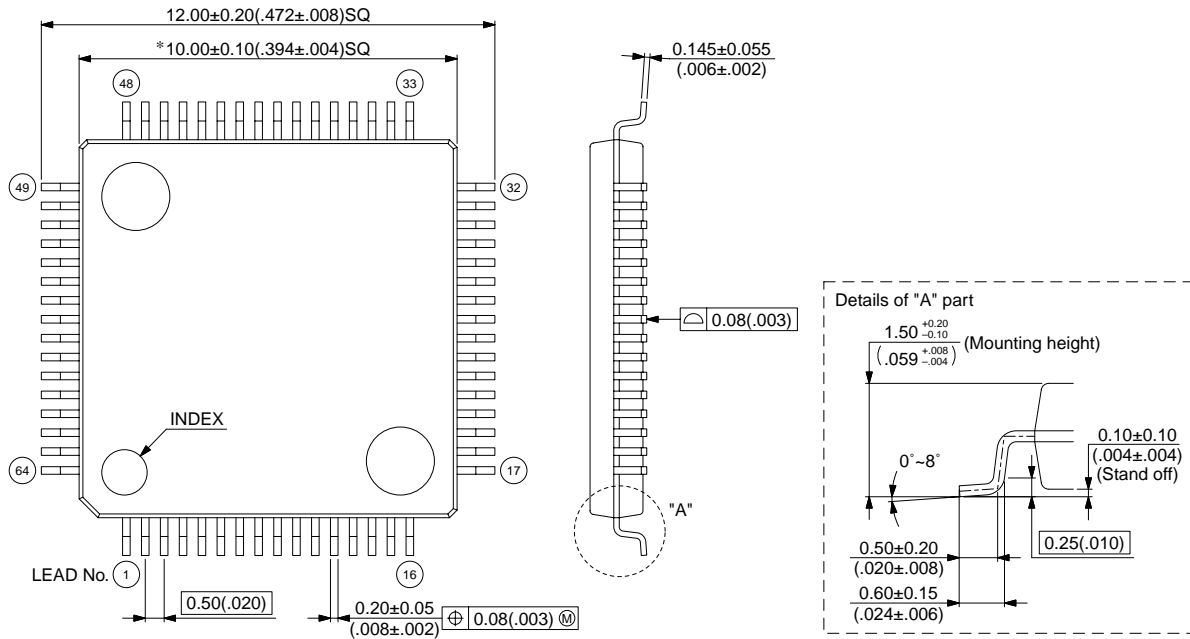

© 2005 FUJITSU LIMITED F64036S-c-1-1

Dimensions in mm (inches) .

Note : The values in parentheses are reference values.

# MB90350 Series

The information for microcontroller supports is shown in the following homepage.  
<http://www.fujitsu.com/global/services/microelectronics/product/micom/support/index.html>

## FUJITSU LIMITED

All Rights Reserved.

The contents of this document are subject to change without notice. Customers are advised to consult with FUJITSU sales representatives before ordering.

The information, such as descriptions of function and application circuit examples, in this document are presented solely for the purpose of reference to show examples of operations and uses of Fujitsu semiconductor device; Fujitsu does not warrant proper operation of the device with respect to use based on such information. When you develop equipment incorporating the device based on such information, you must assume any responsibility arising out of such use of the information. Fujitsu assumes no liability for any damages whatsoever arising out of the use of the information.

Any information in this document, including descriptions of function and schematic diagrams, shall not be construed as license of the use or exercise of any intellectual property right, such as patent right or copyright, or any other right of Fujitsu or any third party or does Fujitsu warrant non-infringement of any third-party's intellectual property right or other right by using such information. Fujitsu assumes no liability for any infringement of the intellectual property rights or other rights of third parties which would result from the use of information contained herein.

The products described in this document are designed, developed and manufactured as contemplated for general use, including without limitation, ordinary industrial use, general office use, personal use, and household use, but are not designed, developed and manufactured as contemplated (1) for use accompanying fatal risks or dangers that, unless extremely high safety is secured, could have a serious effect to the public, and could lead directly to death, personal injury, severe physical damage or other loss (i.e., nuclear reaction control in nuclear facility, aircraft flight control, air traffic control, mass transport control, medical life support system, missile launch control in weapon system), or (2) for use requiring extremely high reliability (i.e., submersible repeater and artificial satellite).

Please note that Fujitsu will not be liable against you and/or any third party for any claims or damages arising in connection with above-mentioned uses of the products.

Any semiconductor devices have an inherent chance of failure. You must protect against injury, damage or loss from such failures by incorporating safety design measures into your facility and equipment such as redundancy, fire protection, and prevention of over-current levels and other abnormal operating conditions.

If any products described in this document represent goods or technologies subject to certain restrictions on export under the Foreign Exchange and Foreign Trade Law of Japan, the prior authorization by Japanese government will be required for export of those products from Japan.

## Looking for pricing, stock, or lifecycle information?

Click below to explore more details on WIN SOURCE:

- ⊖ [View MB90F352SPFM-GS-DE1 on WIN SOURCE](#)
- ⊖ [Cypress Semiconductor Corp Information](#)

## Optimize Your Supply Chain with WIN SOURCE Solutions

- ✓ Global Sourcing Solution
- ✓ Obsolete Management
- ✓ Cost Control Management
- ✓ Shortage Management
- ✓ Alternative Solution
- ✓ Excess Inventory Management