



THE DATASHEET OF
481681211



NOTE:

1. TAPE SIZE 29.5mm
2. STAPLES SHOULD ONLY BE USED TO SET UP CARTON
- ALL CARTONS CLOSURES MUST BE DONE WITH TAPE.
3. FILL PACKAGING REEL WITH THE QUANTITIES AS INDICATED IN THE CHART.

PRODUCT P/N	PARTS PER PRIMARY CARTON	PARTS PER REEL	TOTAL REELS PER PRIMARY CARTON
48168-1201 48168-1211	7000(PCS)	1400(PCS)	5
48168-3001 48168-3011	5600(PCS)	1400(PCS)	4

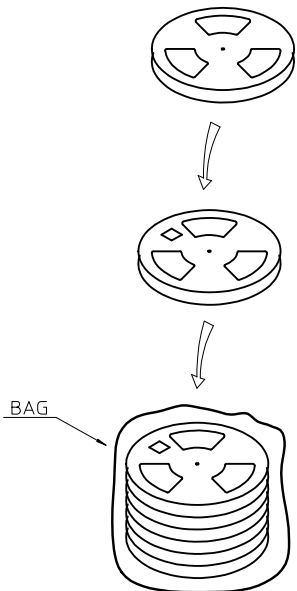

PRIMARY CARTON
096707-0007

2 DESICCATING AGENT

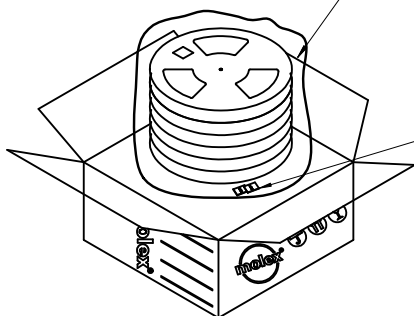

PRIMARY CARTON
096707-0007

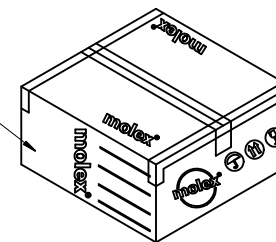

REVISE EC NO: SH2010-0365 DRWN: YANG05 2010/03/12 CHK: ERIC KAO 2005/07/05 APPR: RZHANG 2010/04/30	DESCRIPTION REV	QUALITY SYMBOLS	GENERAL TOLERANCES (UNLESS SPECIFIED)		DIMENSION STYLE MM ONLY		SCALE 6:1	DESIGN UNITS METRIC	THIRD ANGLE PROJECTION																	
		$\nabla_F = 0$ $\nabla_{F'} = 0$ $\nabla_{F''} = 0$	<table border="1"> <thead> <tr> <th></th> <th>mm</th> <th>INCH</th> </tr> </thead> <tbody> <tr> <td>4 PLACES</td> <td>± ---</td> <td>± ---</td> </tr> <tr> <td>3 PLACES</td> <td>± ---</td> <td>± ---</td> </tr> <tr> <td>2 PLACES</td> <td>± 0.25</td> <td>± ---</td> </tr> <tr> <td>1 PLACE</td> <td>± 0.25</td> <td>± ---</td> </tr> </tbody> </table>		mm	INCH	4 PLACES	± ---	± ---	3 PLACES	± ---	± ---	2 PLACES	± 0.25	± ---	1 PLACE	± 0.25	± ---	ANGULAR ± 3 °		DRAWN BY BERNIE	DATE 2005/07/05	TITLE MDC 0.8 MM BTB RECEPTACLE CONNECTOR PACKAGING			
			mm	INCH																						
		4 PLACES	± ---	± ---																						
3 PLACES	± ---	± ---																								
2 PLACES	± 0.25	± ---																								
1 PLACE	± 0.25	± ---																								
DRAFT WHERE APPLICABLE MUST REMAIN WITHIN DIMENSIONS		SEE TABLE		CHECKED BY ERIC KAO	DATE 2005/07/05	MOLEX INCORPORATED																				
				APPROVED BY RZHANG	DATE 2010/04/14	DOCUMENT NO. PK-48168-001		SHEET NO. 1 OF 3																		

10 9 8 7 6 5 4 3 2 1

CKT	DIMA	DIMB	DIMC	DIMD
10		8.50		
12		9.30		
14	11.50	10.10	24.00	24.40
16		10.90		
20		12.50		
24		14.10		

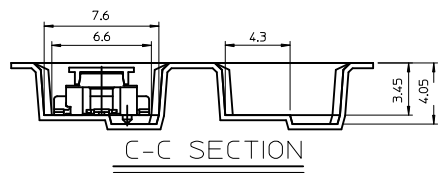
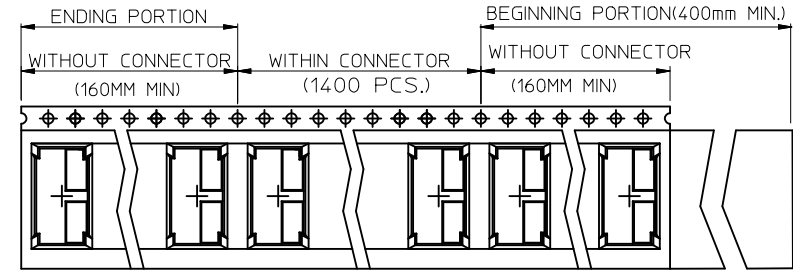
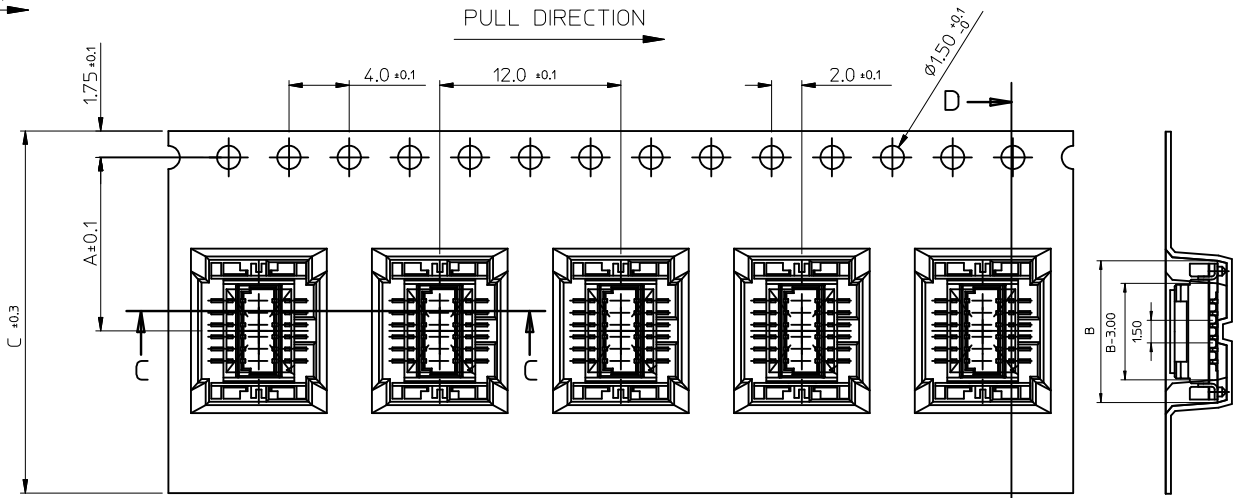
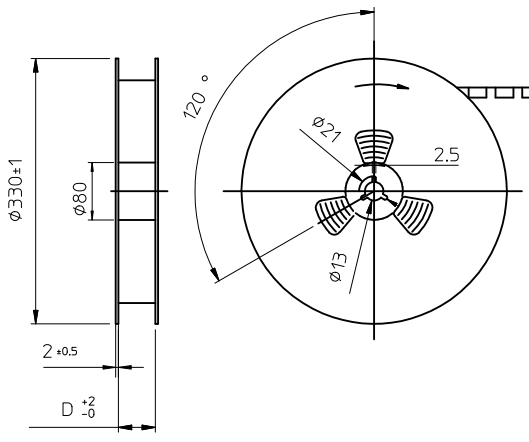
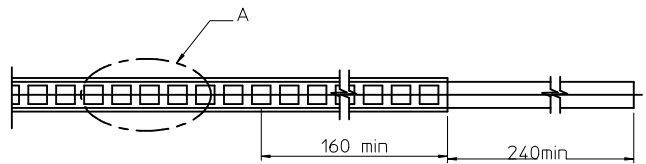

NOTE:
 1. QUANTITY 1400 PCS / REEL
 2. USER DIRECTION OF FEED

3. COVER TAPE PEELING FORCE:
 PULL OUT DIRECTION

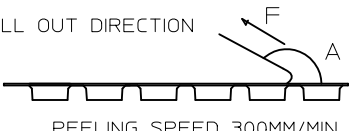

A	165°~ 180°
F	0.1N~1.3N

4. PART DIMENSIONS MEET EIA-481-2-A REQUIREMENT
 5. THICKNESS: 0.35±0.05 MM

REVISE	DESCRIPTION
EC NO: SH2010-0365	
DRWN: YANG05	2010/03/12
CHKD: ERIC KAO	2005/07/05
APPR: RZHANG	2010/04/20

QUALITY SYMBOLS	GENERAL TOLERANCES (UNLESS SPECIFIED)
$\nabla_F = 0$	mm INCH
$\nabla_E = 0$	4 PLACES ± --- ± ---
$\nabla_D = 0$	3 PLACES ± --- ± ---
	2 PLACES ± 0.25 ± ---
	1 PLACE ± 0.25 ± ---
	ANGULAR ± 3°

DIMENSION STYLE		SCALE	DESIGN UNITS	THIRD ANGLE PROJECTION
MM ONLY		1:1	METRIC	
DRAWN BY	DATE	TITLE		
BERNIE	2005/07/05	MDC 0.8 MM BTB RECEPTACLE CONNECTOR PACKAGING		
CHECKED BY	DATE	MOLEX INCORPORATED		
ERIC KAO	2005/07/05	DOCUMENT NO. PK-48168-001		
APPROVED BY	DATE	SHEET NO. 2 OF 3		
RZHANG	2010/04/14	THIS DRAWING CONTAINS INFORMATION THAT IS PROPRIETARY TO MOLEX INCORPORATED AND SHOULD NOT BE USED WITHOUT WRITTEN PERMISSION		
MATERIAL NO.		SEE SHEET 1		

9 8 7 6 5 4 3 2 1

CKT	DIMA	DIMB	DIMC	DIMD	DIME
30	14.2±0.10	16.50	32.00	32.40	28.40

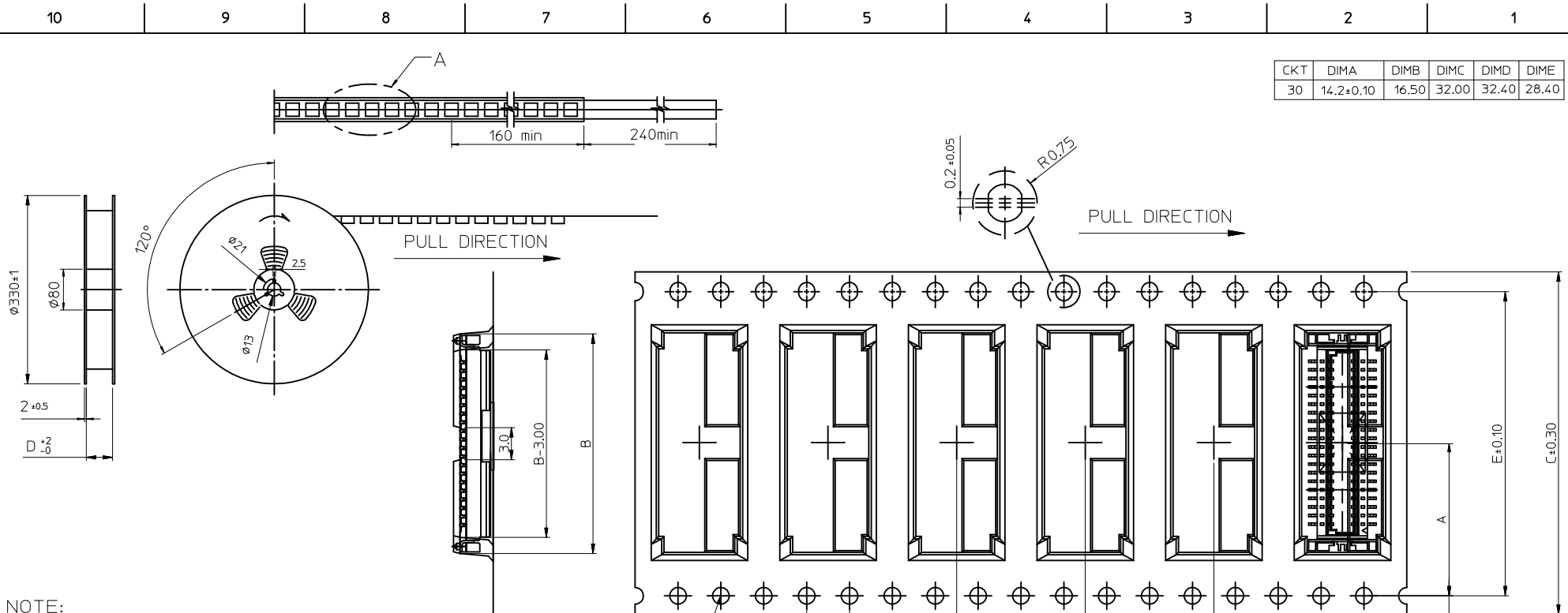

- NOTE:
1. QUANTITY 1400 PCS / REEL
 2. USER DIRECTION OF FEED

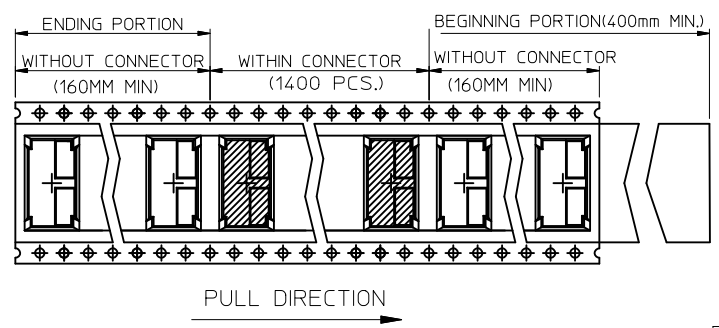

3. COVER TAPE PEELING FORCE: 0.12 kgf.

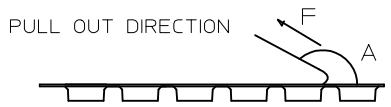

A	165° ~ 180°
F	0.1N ~ 1.3N

- PEELING SPEED 300MM/MIN
4. PART DIMENSIONS MEET EIA-481-2-A REQUIREMENT
 5. THICKNESS: 0.35±0.05 MM

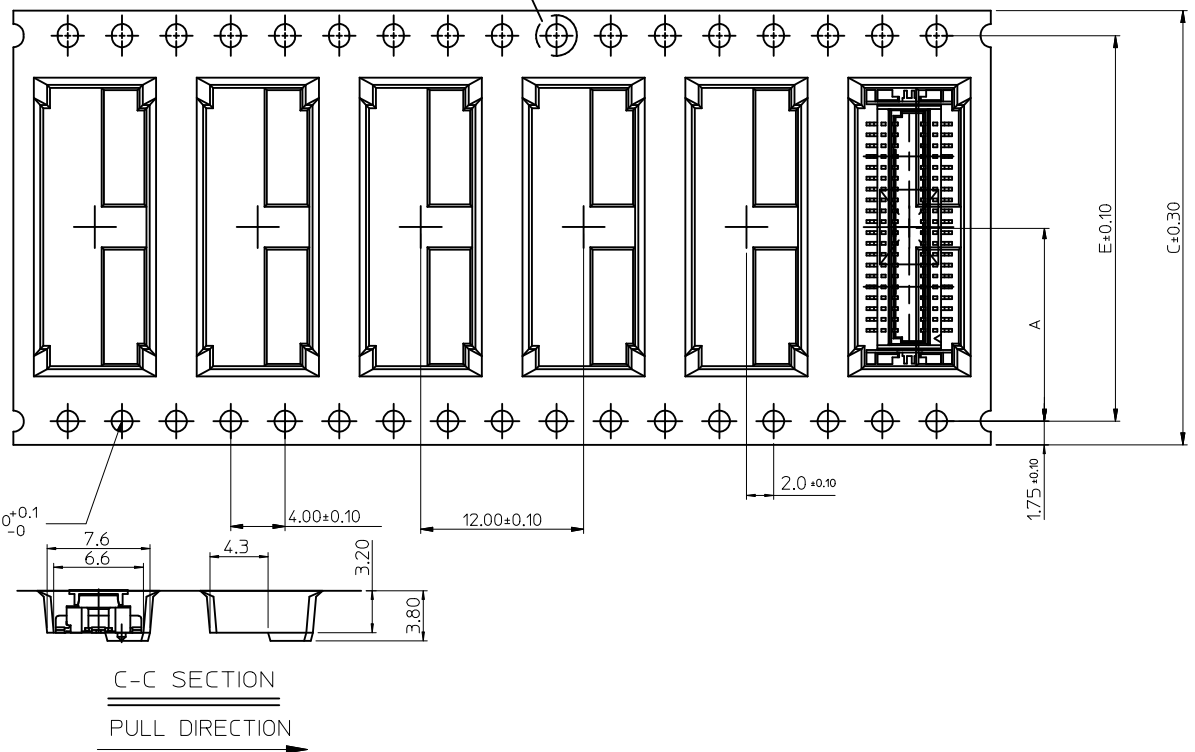

REVISE	REV	DESCRIPTION	QUALITY SYMBOLS	GENERAL TOLERANCES (UNLESS SPECIFIED)		DIMENSION STYLE		SCALE	DESIGN UNITS	THIRD ANGLE PROJECTION
				mm	INCH	MM ONLY	1:1	METRIC		
DRW: F. YANG05	2010/03/12	2010/03/12	▽ _A =0	4 PLACES	± ---	± ---	DRAWN BY	DATE	TITLE	MDC 0.8 MM BTB RECEPTACLE CONNECTOR PACKAGING
CHK: D. ERIC KAO	2005/07/05	2005/07/05	▽ _F =0	3 PLACES	± ---	± ---	CHECKED BY	DATE		
APP: R. ZHANG	2010/04/30	2010/04/30	▽ _F =0	2 PLACES	± 0.25	± ---	APPROVED BY	DATE		MOLEX INCORPORATED
				1 PLACE	± 0.25	± ---	RZHANG	2010/04/14		
				ANGULAR ± 3 °			MATERIAL NO.			DOCUMENT NO. PK-48168-001
				DRAFT WHERE APPLICABLE MUST REMAIN WITHIN DIMENSIONS			SEE SHEET 1			
							SIZE A3	THIS DRAWING CONTAINS INFORMATION THAT IS PROPRIETARY TO MOLEX INCORPORATED AND SHOULD NOT BE USED WITHOUT WRITTEN PERMISSION		

10 9 8 7 6 5 4 3 2 1

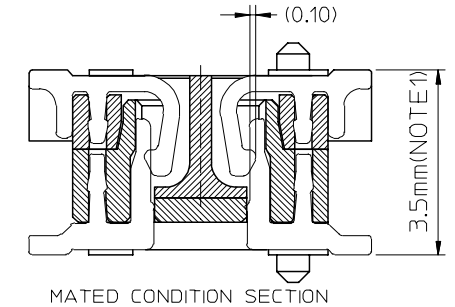
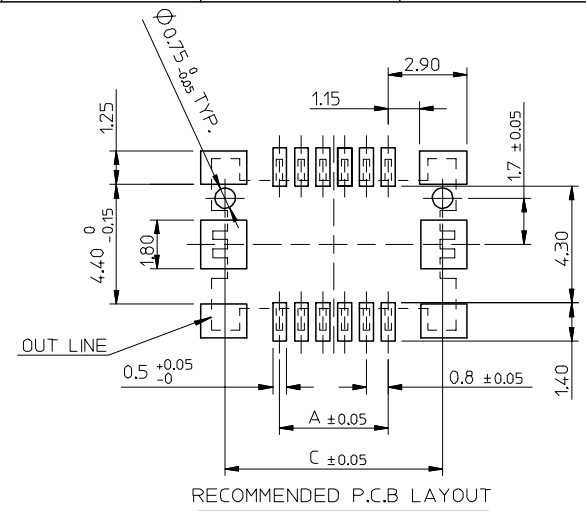
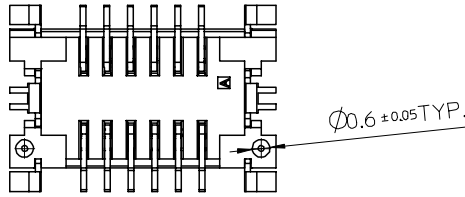
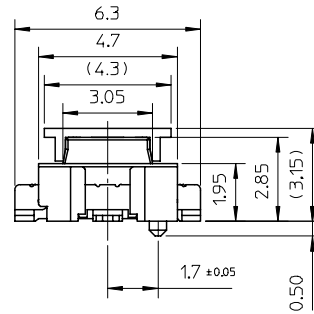
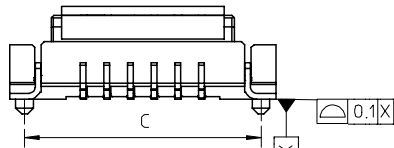
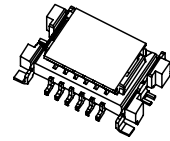
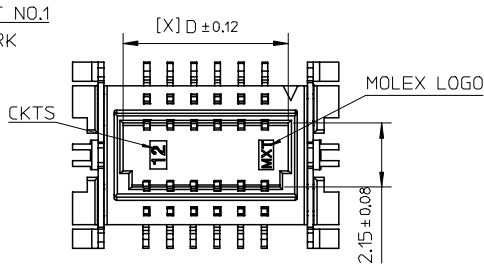
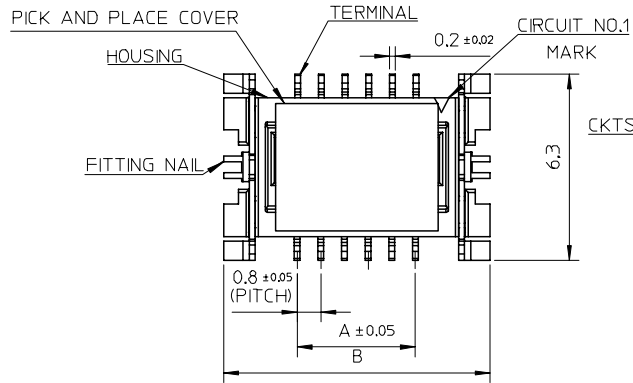

NOTES
 1.COPLANARITY IS 0.1mm MAX.
 2.MATERIAL : HOUSING-HIGH TEMPERATURE THERMOPLASTIC, GLASS FILLED, UL 94V-0, COLOR: NATURE(WHITE)
 TERMINAL- COPPER ALLOY
 FITTING NAIL- COPPER ALLOY
 PICK AND PLACE COVER-HIGH TEMPERATURE THERMOPLASTIC, GLASS FILLED,UL 94V-0, COLOR: NATURE(WHITE)
 3.FINISHES : TERMINAL :48168-XX01:
 TIN MATT PLATED OVER ALL THICKNESS :0.025 MICROMETER
 NICKEL UNDERPLATED OVER ALL THICKNESS :1.27 MICROMETER
 48168-XX11:
 GOLD FLASH OVER ALL THICKNESS :0.025 MICROMETER MINIMUM;
 NICKEL UNDERPLATED OVER ALL THICKNESS :1.27 MICROMETER
 FITTING NAIL :48168-XX01:
 TIN MATT PLATED OVER ALL THICKNESS :0.025 MICROMETER
 NICKEL UNDERPLATED OVER ALL THICKNESS :1.27 MICROMETER
 48168-XX11:
 GOLD FLASH OVER ALL THICKNESS :0.025 MICROMETER MINIMUM;
 NICKEL UNDERPLATED OVER ALL THICKNESS :1.27 MICROMETER MINIMUM;

4.PRODUCT SPECIFICATION REFER TO PS-48126-001
 5.DRAWING PACKAGING REFER TO PK-48168-001
 6.TEST SUMMARY REFER TO TS-48210-001
 7.MATED WITH 48126-SERIES
 8.P/N LEGEND 48168-XXX1

NO OF CKTS PLATING
 0:MATT TIN
 1:GOLD FLASH OVER ALL

9.LEAD-FREE AND ROHS COMPLIANCE

DIMA	DIMB	DIMC	DIMD	CKT	AVAILABLE
3.2	8.2	7.2	4.8	10	-
4.0	9.0	8.0	5.6	12	YES
4.8	9.8	8.8	6.4	14	-
5.6	10.6	9.6	7.2	16	-
7.2	12.2	11.2	8.8	20	-
8.8	13.8	12.8	10.4	24	-
11.2	16.2	15.2	12.8	30	YES

RELEASED EC NO: SH2005-0240 DRW:EKAO01 CHKD: APPR:WMSCHANG	2005/11/03 2005/11/03 2005/11/04	DESCRIPTION QUALITY SYMBOLS ▽=0 ▽=0	GENERAL TOLERANCES (UNLESS SPECIFIED)		DIMENSION STYLE IN/MM		SCALE 6:1	DESIGN UNITS INCH	THIRD ANGLE PROJECTION			
					DRAWN BY BERNIE		DATE 2005/01/25		TITLE MDC BOARD TO BOARD RECEPTACLE CONNECTOR (LEAD-FREE VERSION)			
					CHECKED BY ERIC		DATE 2005/01/25		MOLEX INCORPORATED			
					APPROVED BY WILSON		DATE 2005/01/25		DOCUMENT NO. SD-48168-001		SHEET NO. 1 OF 1	
DRAFT WHERE APPLICABLE MUST REMAIN WITHIN DIMENSIONS			SIZE A3		SEE NOTES				THIS DRAWING CONTAINS INFORMATION THAT IS PROPRIETARY TO MOLEX INCORPORATED AND SHOULD NOT BE USED WITHOUT WRITTEN PERMISSION			

9 8 7 6 5 4 3 2 1

Looking for pricing, stock, or lifecycle information?

Click below to explore more details on WIN SOURCE:

 [View 481681211 on WIN SOURCE](#)

 [Molex, LLC Information](#)

Optimize Your Supply Chain with WIN SOURCE Solutions

-  Global Sourcing Solution
-  Obsolete Management
-  Cost Control Management
-  Shortage Management
-  Alternative Solution
-  Excess Inventory Management