



**THE DATASHEET OF  
MC33565DR2G**



# MC33565

## Smart Voltage Regulator for Peripheral Card Applications

The MC33565 Low Drop Out Voltage Regulator is designed for computer peripheral card applications, allowing glitch-free transitions from “sleep” to “active” system modes. It has internal logic circuitry to detect whether there is a 5.0 V supply (“active” system mode) or an auxiliary 3.3 V supply (“sleep” system mode). A guaranteed 3.3 V regulated output voltage at 200 mA is always available even if the main 5.0 V supply drops out.

The regulated 3.3 V output voltage is provided by either an internal low dropout voltage regulator or an external P-channel MOSFET switch, depending on the system being in the “active” or “sleep” mode.

### Features

- Glitch-Free Transition from “Sleep” to “Active” Mode
- Compatible with *Instantly Available* PC Systems
- Output Current up to 200 mA
- Output Regulated to 2% over Temperature
- Excellent Line and Load Regulation (0.4%)
- Prevents Reverse Current Flow during Sleep Mode
- Short Circuit Protection
- Pb-Free Packages are Available

### Applications

- Computer
- Ethernet
- PCI/NIC Cards

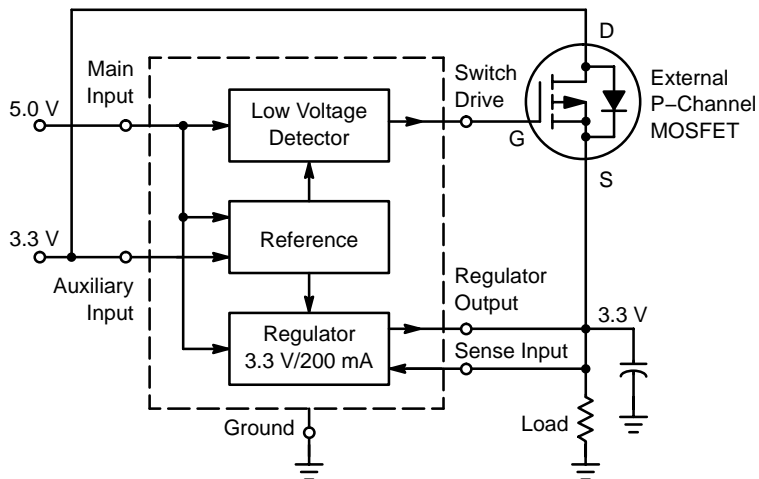

Figure 1. Simplified Block Diagram



ON Semiconductor®

<http://onsemi.com>

### MARKING DIAGRAMS

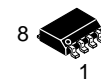

SOIC-8  
D SUFFIX  
CASE 751

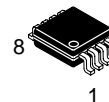
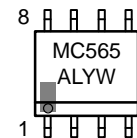

Micro8™  
(MSOP-8)  
DM SUFFIX  
CASE 846A

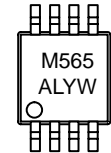

A = Assembly Location  
L = Wafer Lot  
Y = Year  
W = Work Week

### PIN CONNECTIONS

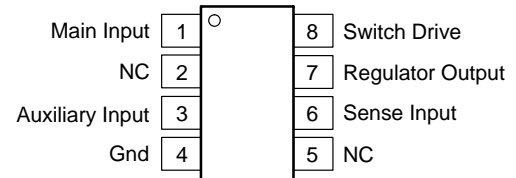

Pins 2 and 5 are not internally connected

### ORDERING INFORMATION

Device	Package	Shipping†
MC33565D	SOIC-8	98 Units / Rail
MC33565DR2	SOIC-8	2500 / Tape & Reel
MC33565DMR2	Micro8	4000 / Tape & Reel
MC33565DG	SOIC-8 (Pb-Free)	98 Units / Rail
MC33565DR2G	SOIC-8 (Pb-Free)	2500 / Tape & Reel
MC33565DMR2G	Micro8 (Pb-Free)	4000 / Tape & Reel

†For information on tape and reel specifications, including part orientation and tape sizes, please refer to our Tape and Reel Packaging Specification Brochure, BRD8011/D.

# MC33565

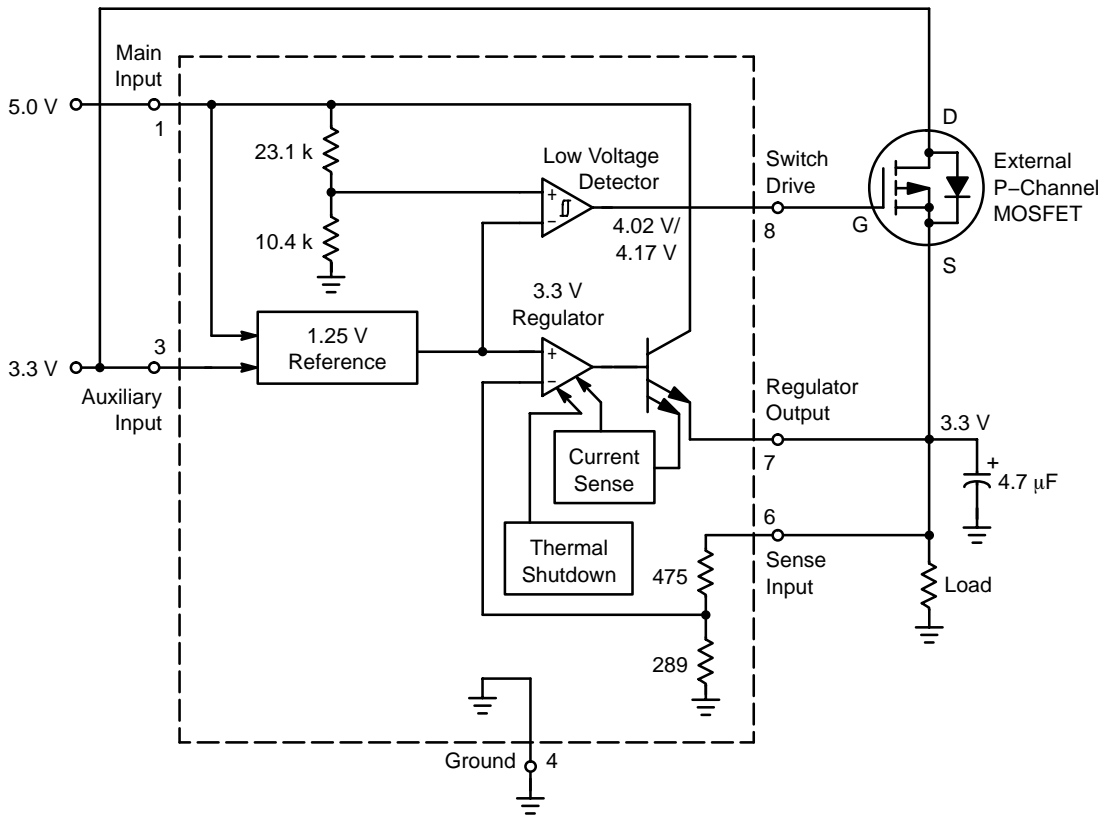

Figure 2. Functional Block Diagram

## PIN ASSIGNMENTS AND FUNCTIONS

PIN #	FUNCTION	PIN DESCRIPTION
1	Main Input	This input connects to the system main power source, typically 5.0 V.
2, 5	NC	No connection. These pins are not internally connected.
3	Auxiliary Input	This input connects to the system auxiliary power source, typically 3.3 V.
4	Gnd	This is the regulator and control circuit power ground.
6	Sense Input	The sense input connects directly to the load allowing precise regulation.
7	Regulator Output	This output is precisely regulated at 3.3 V and is capable of up to 200 mA.
8	Switch Drive	This output is designed to drive the gate of an external P-channel MOSFET switch.

# MC33565

## MAXIMUM RATINGS (Notes 1, 2)

Rating	Symbol	Value	Unit
Main Input Voltage Range (Pin 1)	$V_{in(M)}$	-0.5 to +7.0	V
Auxiliary Input Voltage Range (Pin 3)	$V_{in(A)}$	-0.5 to +7.0	V
Thermal Resistance Junction to Air D Suffix, SOIC-8, Case 751 DM Suffix, MSOP-8, Case 846A	$R_{\theta JA}$	146 172	°C/W
Operating Junction Temperature Range	$T_J$	-5.0 to +150	°C
Storage Temperature Range	$T_{stg}$	-55 to +150	°C
Lead Temperature (Soldering, 10 seconds)	$T_L$	300	°C

**ELECTRICAL CHARACTERISTICS** ( $V_{in(A)} = 3.3$  V,  $V_{in(M)} = 5.0$  V, Pin 6 connected to Pin 7,  $C_{pin6,7} = 4.7$   $\mu$ F, for typical values  $T_J = 25^\circ$ C, for min/max values  $T_J = -5.0^\circ$ C to  $150^\circ$ C unless otherwise noted.)

Characteristic	Symbol	Min	Typ	Max	Unit
----------------	--------	-----	-----	-----	------

### MAIN INPUT (Pin 1)

Operating Voltage Range	$V_{in(M)}$	4.3	5.0	5.5	V
Quiescent Current ( $I_O = 0$ mA)	$I_{Q(M)}$	-	8.0	10	mA
Output to Input Reverse Leakage Current ( $V_{in(M)} = 0$ V, $V_{out} = 3.5$ V, $T_J = 25^\circ$ C)	$I_L$	-	1.4	25	$\mu$ A

### AUXILIARY INPUT (Pin 3)

Quiescent Current ( $I_O = 0$ mA)	$I_{Q(A)}$	-	1.9	3.0	mA
-----------------------------------	------------	---	-----	-----	----

### REGULATOR OUTPUT (Pin 7)

Output Voltage ( $I_O = 0$ mA to 200 mA, Note 3) $V_{in(M)} = 4.3$ V to 5.5 V $T_A = 25^\circ$ C $T_J = -5.0^\circ$ C to $150^\circ$ C $V_{in(M)} = V_{th(L)}$ $V_{in(M)} = 7.0$ V	$V_{out}$	3.267 3.234 3.0 3.1	3.3 3.3 -	3.333 3.366 -	3.5 -	V
Line Regulation	$Reg_{line}$	-	1.5	13.2		mV
Load Regulation	$Reg_{load}$	-	1.9	13.2		mV
Short Circuit Current ( $T_J = 25^\circ$ C, Note 3)	$I_{SC}$	230	750	800		mA

### LOW VOLTAGE DETECTOR (Pins 1, 8)

Input Threshold Voltage (Figure 3) Output Low State Transition, $V_{in(M)}$ Decreasing Output High State Transition, $V_{in(M)}$ Increasing Hysteresis	$V_{th(L)}$ $V_{th(H)}$ $V_H$	3.9 -	4.02 4.17	4.3 4.3	0.120 0.150 0.180	V
---	-------------------------------------	----------	--------------	------------	-------------------------	---

### SWITCH DRIVE OUTPUT (Pin 8)

Output Voltage Low State ( $V_{in(M)} = 0$ V, $V_{in(A)} = 3.3$ V, $I_{sink} = 200$ $\mu$ A) High State ( $V_{in(M)} = 5.0$ V, $V_{in(A)} = 0$ V, $I_{source} = 200$ $\mu$ A)	$V_{O(L)}$ $V_{O(H)}$	- 3.4	0.044 4.15	0.2 -		V
Peak Output Current ( $C_L = 1.2$ nF) Sink Current ( $V_{in(M)} = 3.9$ V, $V_O = 1.0$ V) Source Current ( $V_{in(M)} = 4.3$ V, $V_O = 2.3$ V)	$I_{sink(PK)}$ $I_{source(PK)}$	15 15	22 39	- -		mA
Propagation Delay, Main Input to Switch Drive Output (Figure 4) $C_L = 1.2$ nF Switch Drive Output Fall ( $V_{in(M)}$ Decreasing) Switch Drive Output Rise ( $V_{in(M)}$ Increasing)	$t_{DL}$ $t_{DH}$	- -	0.65 1.4	3.5 3.5		$\mu$ s

- Maximum Ratings are those values beyond which damage to the device may occur.
- This device series contains ESD protection and exceed the following tests:  
Human Body Model 2500 V per MIL STD 883, Method 3015.  
Machine Model Method 400 V.
- Thermal shutdown activation can occur when the maximum operating junction temperature is exceeded.

TYPICAL CHARACTERISTICS

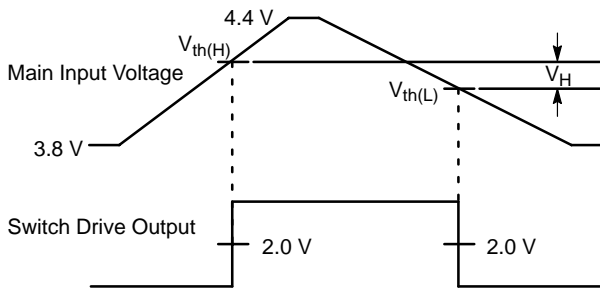

$V_{in(M)}$  rise and fall times (10% to 90%) to be  $\geq 100 \mu s$ .

Figure 3. Low Voltage Detector Thresholds

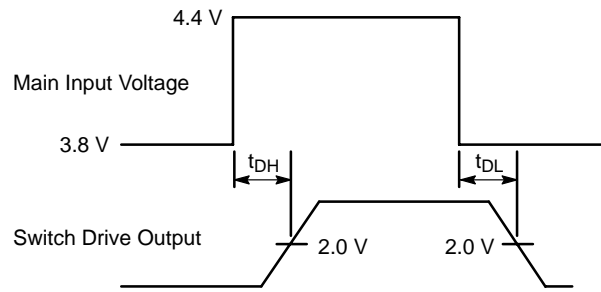

$V_{in(M)}$  rise and fall times (10% to 90%) to be  $\leq 100 ns$ .

Figure 4. Switch Drive to Main Input Timing Diagram

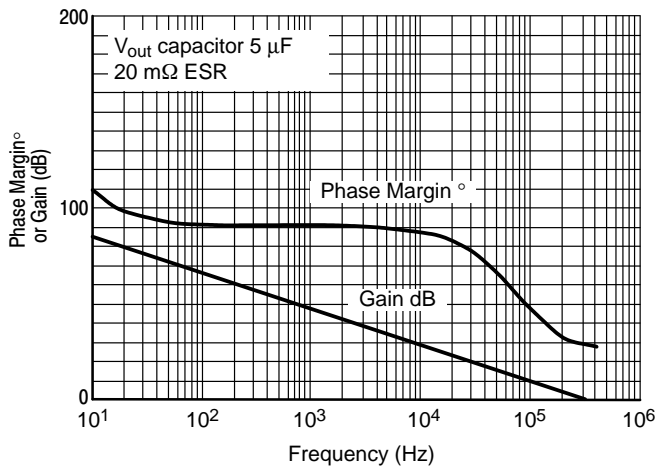

$V_{out}$  capacitor  $\geq 4.7 \mu F$  over operating temperature range. Maximum ESR permissible = 500 m $\Omega$  over operating temperature range.

Figure 5. Predicted Gain and Phase at Zero Load Current

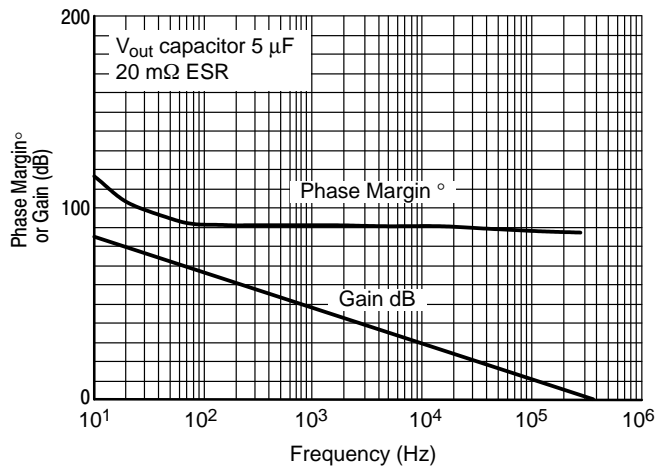
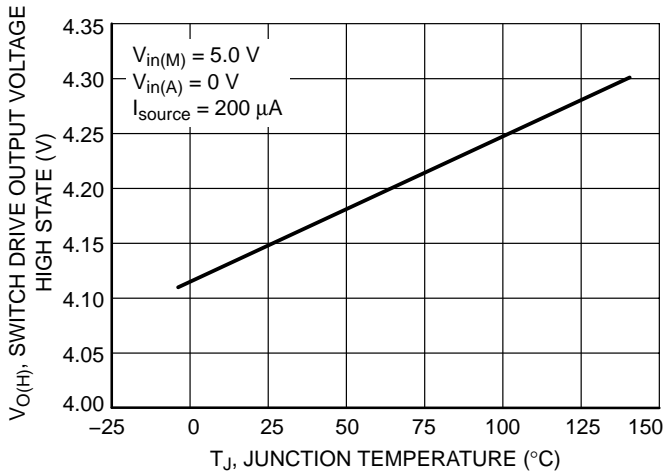
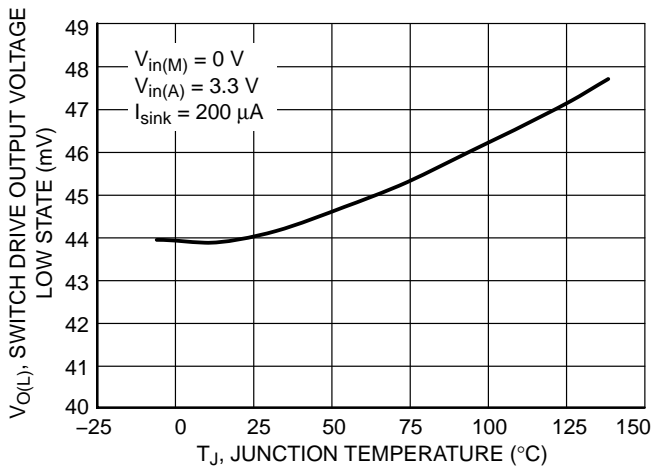

Figure 6. Predicted Gain and Phase at Full Load Current



**Figure 7. Switch Drive Output Voltage High State (external P-channel MOSFET turned off) vs. Junction Temperature**



**Figure 8. Switch Drive Output Voltage Low State (external P-channel MOSFET turned on) vs. Junction Temperature**

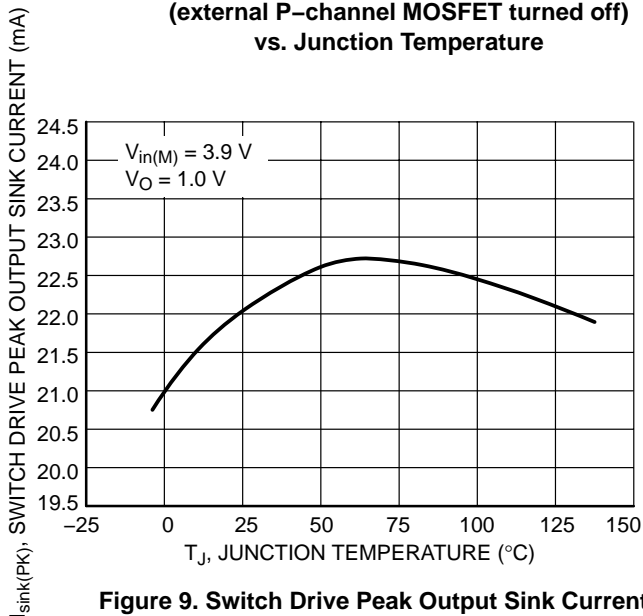

**Figure 9. Switch Drive Peak Output Sink Current vs. Junction Temperature**

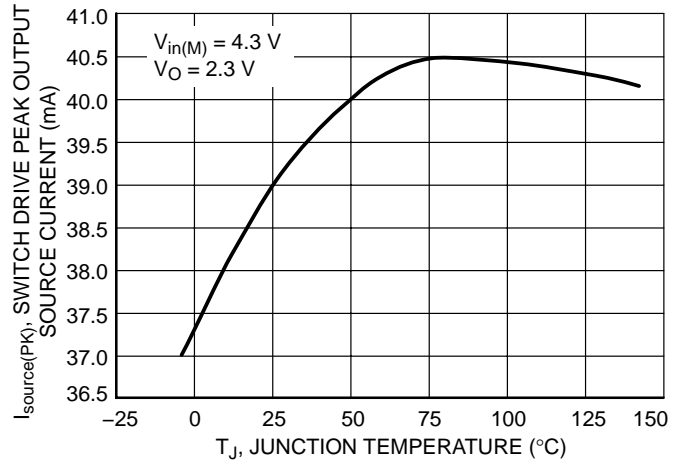

**Figure 10. Switch Drive Peak Output Source Current vs. Junction Temperature**

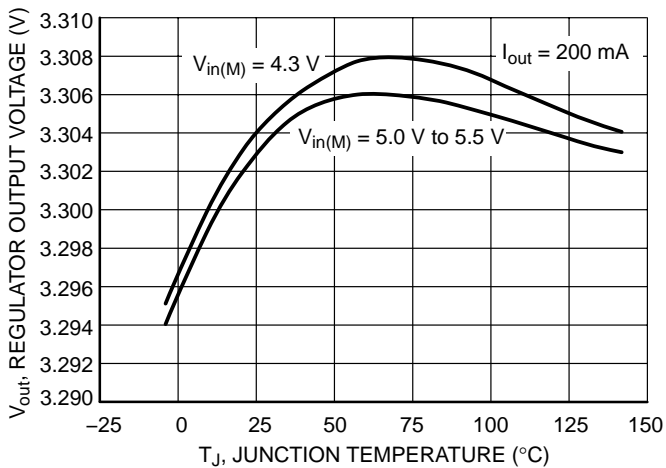

**Figure 11. Regulator Output Voltage vs. Junction Temperature**

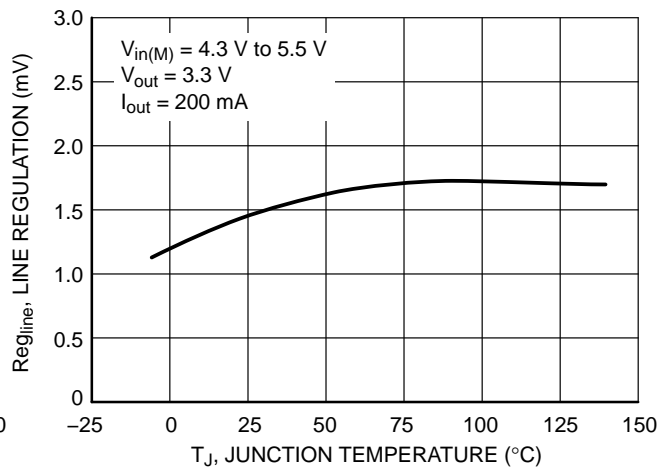

**Figure 12. Line Regulation vs. Junction Temperature**

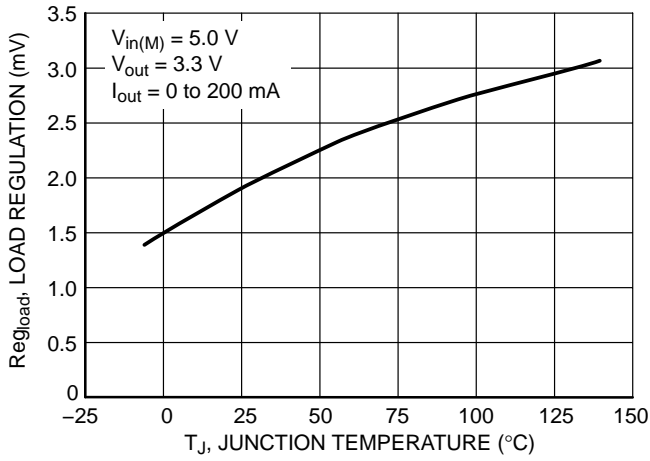

Figure 13. Load Regulation vs. Junction Temperature

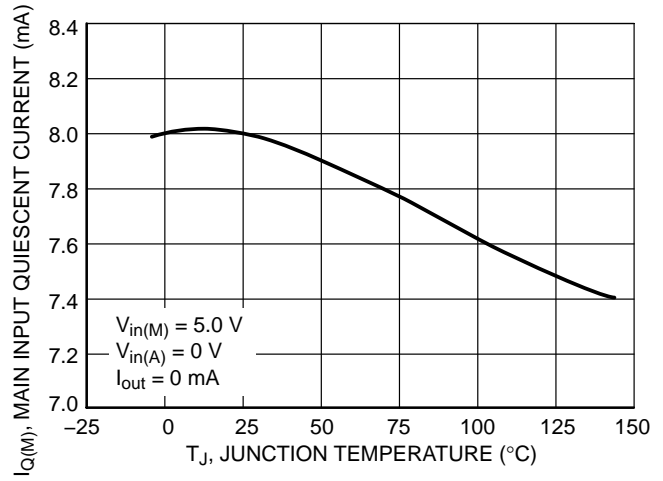

Figure 14. Main Input Quiescent Current vs. Junction Temperature

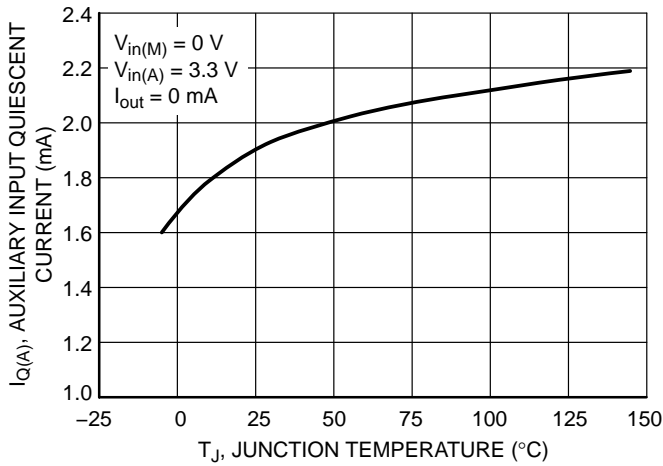

Figure 15. Auxiliary Input Quiescent Current vs. Junction Temperature

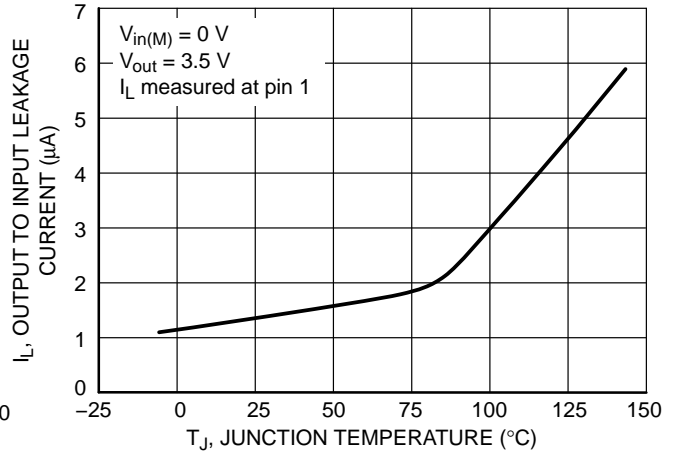

Figure 16. Output to Input Reverse Leakage Current vs. Junction Temperature

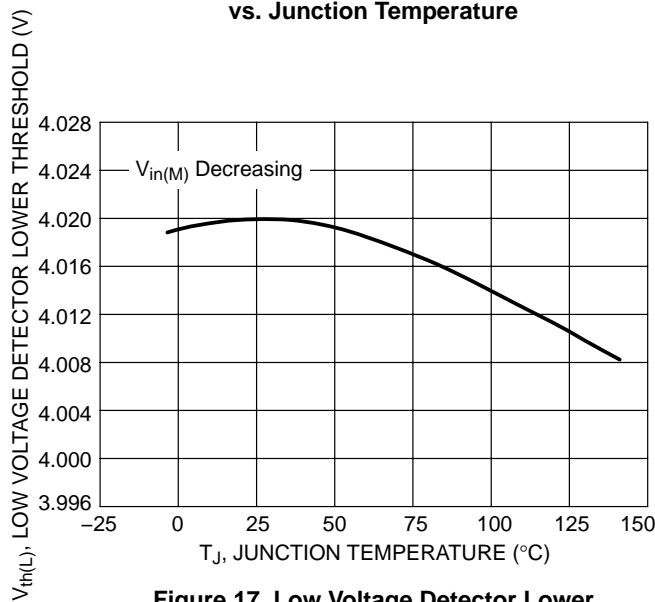

Figure 17. Low Voltage Detector Lower Threshold vs. Junction Temperature

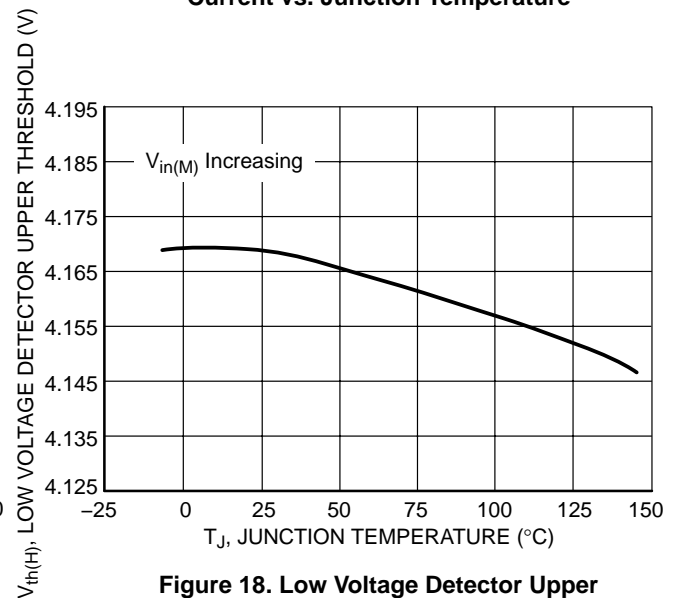

Figure 18. Low Voltage Detector Upper Threshold vs. Junction Temperature

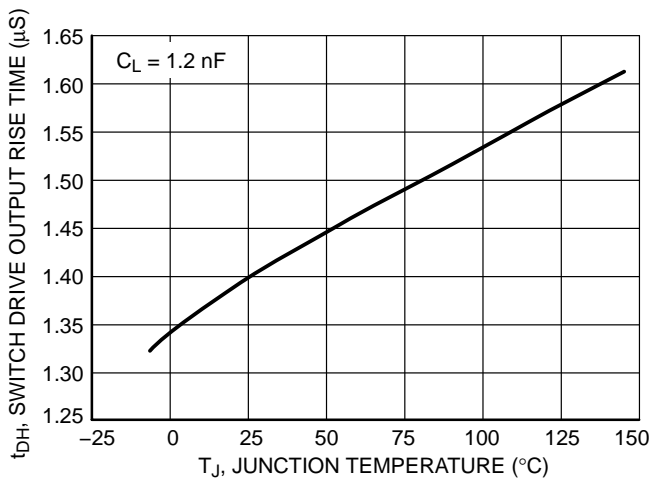

Figure 19. Switch Drive Output Rise Time vs. Junction Temperature

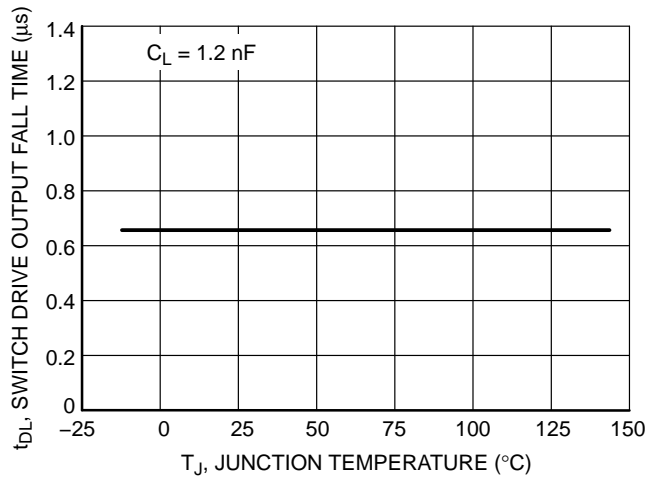

Figure 20. Switch Drive Output Fall Time vs. Junction Temperature

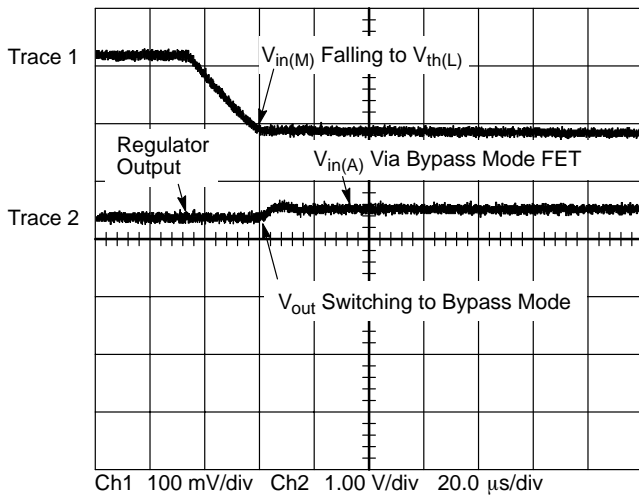

Figure 21. Bypass Mode Transition

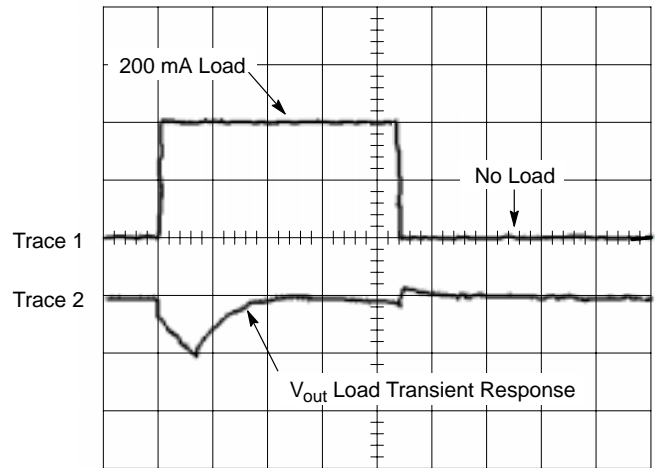

Figure 22. Load Transient Response

## OPERATING DESCRIPTION

The MC33565 is designed for power managed computer applications such as peripheral card interface (PCI) and network interface cards (NIC) where glitch-free transitions between 3.3 V and 5.0 V supplies are necessary. In this type of application, the presence of a 5.0 V supply represents the “active” system mode, while the presence of 3.3 V represents the “sleep” system mode. The MC33565 complies with the *instantly available requirements* as specified by the Advanced Configuration and Power Interface (ACPI) standards set by Intel, Microsoft, and Toshiba. A regulated output voltage of 3.3 V is available even when the 5.0 V supply has been shut down and only the 3.3 V auxiliary supply is available.

The MC33565 has two supply inputs, the Main Input (typically 5.0 V) and an Auxiliary Input (typically 3.3 V). The MC33565 functions as a linear regulator while the Main Input is greater than its lower threshold voltage. Below this threshold, the internal regulator turns off and the 3.3 V output is supplied from the Auxiliary Input via the external P-channel MOSFET. The P-channel MOSFET gate is controlled by the Switch Drive Output.

### Low Voltage Detector

Internal circuitry detects if the system is being powered from the Main or the Auxiliary Input supply. During normal operating conditions, the MC33565 is powered by the Main Input. A regulated output voltage of 3.3 V is provided by an internal low drop out 5.0 V to 3.3 V voltage regulator. While in this mode, the gate of the P-channel MOSFET is driven high, turning the MOSFET Switch OFF.

The internal Low Voltage Detector has typical upper and lower thresholds of 4.17 V and 4.02 V, respectively. The typical hysteresis voltage between the upper and lower thresholds is 150 mV, providing good noise immunity.

If the Main Input supply is not available or the supply voltage drops below the 4.02 V, the internal regulator turns OFF and the Switch Drive goes low. This enables the external MOSFET Switch, connecting the 3.3 V Auxiliary supply to the load allowing the load to remain powered even though the Main Input supply is not available. Once the Main Input supply voltage is above 4.17 V, the MOSFET Switch Drive goes high and the internal regulator is enabled.

The Low Voltage Detector logic is active throughout the entire range of the Main Input supply ramp up. The Switch Drive signal is never turned ON or OFF inappropriately during the Main Input ramp up. The output voltage is kept above 3.0 V while the load is biased from the Main Input supply.

### Input Blocking

The internal regulator pass device (NPN transistor) ensures that no significant reverse current flows from  $V_{out}$  to the Main Supply or Gnd while the output is powered by the Auxiliary Supply. Reverse current is typically less than 6.0  $\mu\text{A}$  over the entire operating temperature range.

### P-Channel MOSFET Switch Polarity

The P-channel MOSFET drain should be connected to the Auxiliary Input, the source to the load and the gate to the Switch Drive Output. It is imperative that the polarity of the P-channel MOSFET is not reversed. If it is reversed, that is the drain connected to the load and the source connected to the Auxiliary supply, the body diode could be forward biased if the Auxiliary supply voltage is below  $V_{out}$ . Consequently, the linear regulator would not turn OFF and it would supply current to the Auxiliary supply rail.

### External Compensation

Regulators are in nature feedback systems. As with any feedback system, loop stability needs to be evaluated to insure stability. The MC33565 requires an external compensation capacitor with a minimum value of 4.7  $\mu\text{F}$  for stability. Increasing the capacitance will improve the overall load transient response. The equivalent series resistance (ESR) of the capacitor should be less than 0.5  $\Omega$  in order for the output voltage to be maintained within tight tolerance.

### Sense

The Sense Input provides tight regulation of the output voltage while the Main supply is present even with varying load current. To take the most benefit of the Sense input, connect pin 6 as close as possible to the load. Use a separate trace to connect the source of the MOSFET Switch to the load as shown in Figure 23. This will help reduce interference or coupling in the Sense Input generated by the output current. The use of the Sense Input is required for correct device operation.

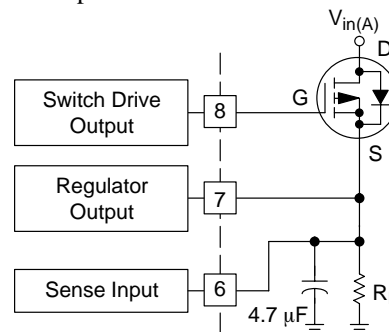

Figure 23. Voltage Regulation Using Sense Feature

### Board Layout

It is recommended that the MC33565 is placed as close as possible to the MOSFET Switch and compensation capacitor. Use short traces to minimize extraneous signals from being induced in the Sense Input or Switch Drive Signals. Also, avoid routing the Sense Input close to the input and load current paths, as well as the Ground return path to prevent signal coupling.

The part list and board layout for a demonstration board using the MC33565 in an SOIC-8 package are available. The board operates with an input voltage between 4.3 V and

# MC33565

5.5 V and provides an output current up to 200 mA. The demonstration board layout (Silk Screen and Top Layers) are shown in Figures 26 and 27, respectively.

### Current Limit and Thermal Shutdown

The MC33565 incorporates current limit and thermal shutdown to protect the device during fault conditions. If the device detects a current limit or short circuit condition, typically 730 mA, the device limits the drive to the internal regulator. Thermal shutdown protects the internal circuitry in the event that maximum junction temperature is exceeded. When activated, typically at 170°C, the output is disabled. There is no hysteresis built into the thermal

limiting circuit. As a result, if the device is overheating, the output will appear to be oscillating. This feature is provided to prevent catastrophic failures from accidental device overheating. **It is not intended to be used as a substitute for proper heatsinking.**

Please consider that the thermal resistance values provided in the maximum ratings table will vary depending on pad size, adjacent components and air flow. If you are planning to operate the device close to its maximum junction temperature it is recommended that you measure the device temperature in your application to insure junction temperature is not exceeded.

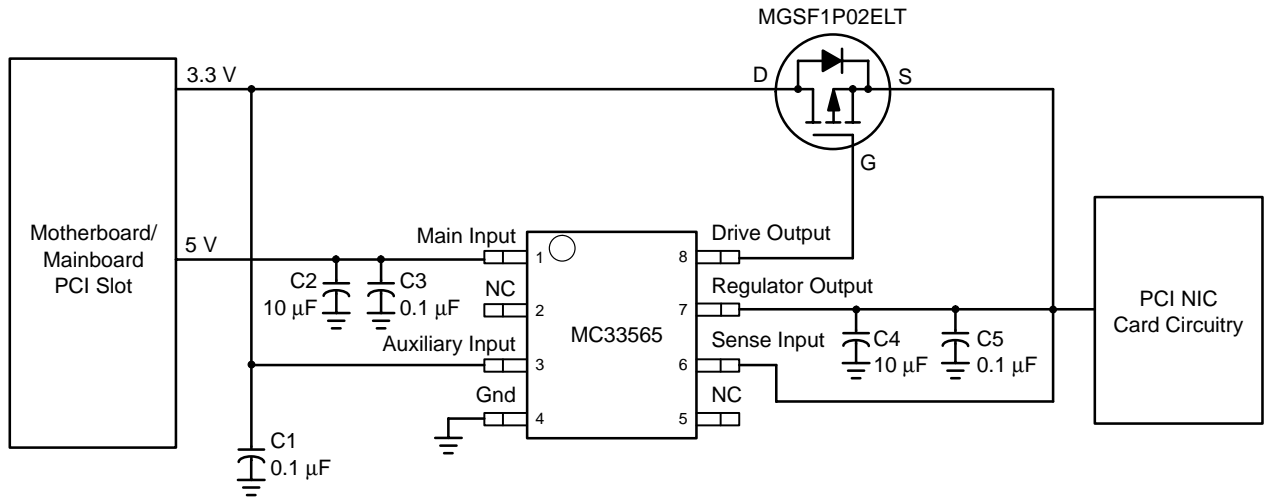

Figure 24. Application Board Schematic (See Figures 26 and 27)

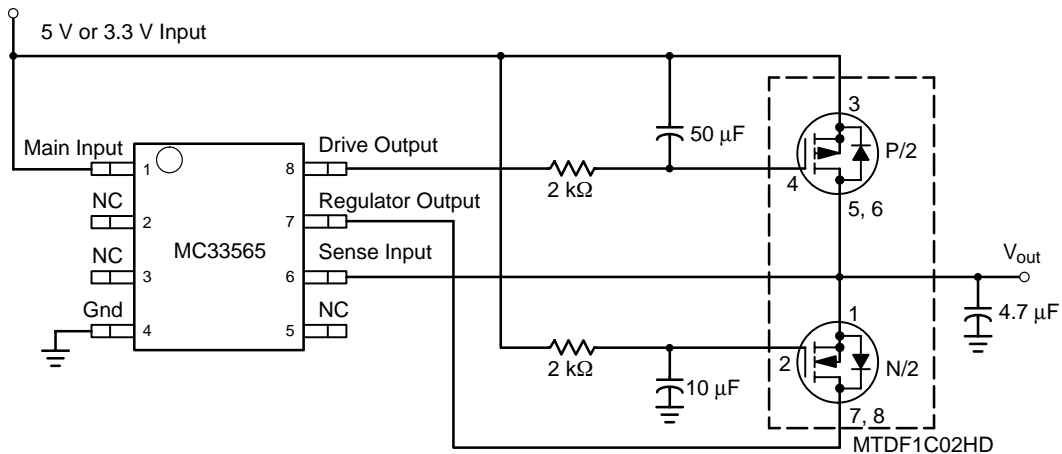

Figure 25. Alternative Application: 5.0 V or 3.3 V Card Input with Hot Swap Circuitry

# MC33565

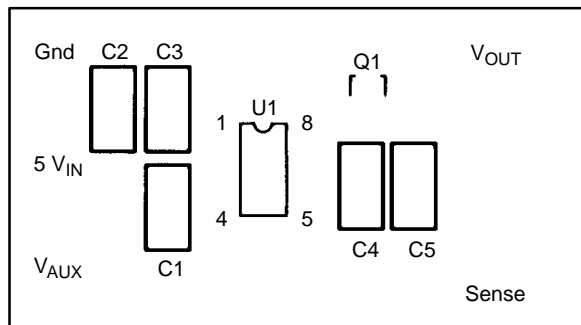

Figure 26. Demonstration Board Silk Screen Layer

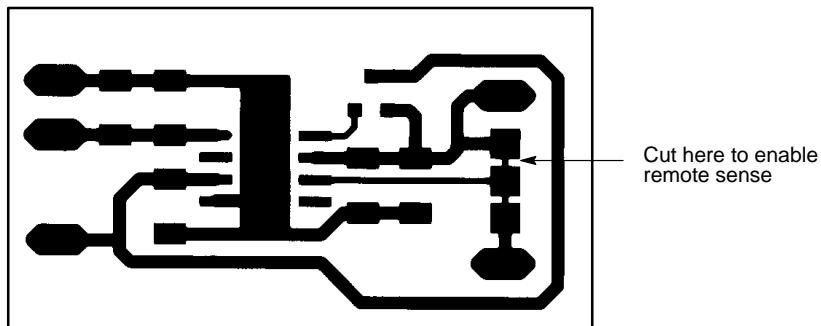

Figure 27. Demonstration Board Top Layer

## PARTS LIST

Qty	Reference	Part/Description	Vendor	Notes
3	C1, C3, C5	0.1 $\mu$ F Ceramic Capacitor	Various	-
2	C2, C4	10 $\mu$ F Tantalum Capacitor	Various	-
1	U1	MC33565D	ON Semiconductor	(SOIC-8 Only)
1	Q1	MGSF1P02ELT	ON Semiconductor	P-Channel MOSFET

# MC33565

## PACKAGE DIMENSIONS

SOIC-8  
D SUFFIX  
CASE 751-07  
ISSUE AE

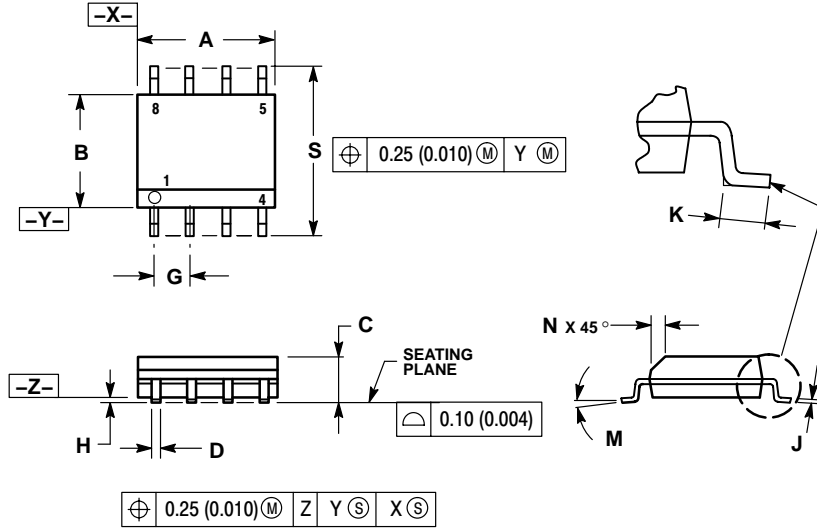

**NOTES:**

1. DIMENSIONING AND TOLERANCING PER ANSI Y14.5M, 1982.
2. CONTROLLING DIMENSION: MILLIMETER.
3. DIMENSION A AND B DO NOT INCLUDE MOLD PROTRUSION.
4. MAXIMUM MOLD PROTRUSION 0.15 (0.006) PER SIDE.
5. DIMENSION D DOES NOT INCLUDE DAMBAR PROTRUSION. ALLOWABLE DAMBAR PROTRUSION SHALL BE 0.127 (0.005) TOTAL IN EXCESS OF THE D DIMENSION AT MAXIMUM MATERIAL CONDITION.
6. 751-01 THRU 751-06 ARE OBSOLETE. NEW STANDARD IS 751-07.

DIM	MILLIMETERS		INCHES	
	MIN	MAX	MIN	MAX
A	4.80	5.00	0.189	0.197
B	3.80	4.00	0.150	0.157
C	1.35	1.75	0.053	0.069
D	0.33	0.51	0.013	0.020
G	1.27 BSC		0.050 BSC	
H	0.10	0.25	0.004	0.010
J	0.19	0.25	0.007	0.010
K	0.40	1.27	0.016	0.050
M	0°	8°	0°	8°
N	0.25	0.50	0.010	0.020
S	5.80	6.20	0.228	0.244

### SOLDERING FOOTPRINT\*

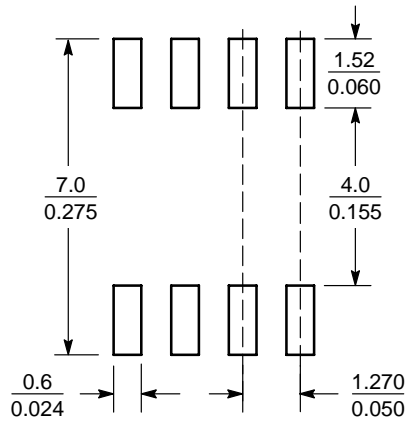

SCALE 6:1  $\left(\frac{\text{mm}}{\text{inches}}\right)$

\*For additional information on our Pb-Free strategy and soldering details, please download the ON Semiconductor Soldering and Mounting Techniques Reference Manual, SOLDERRM/D.

# MC33565

## PACKAGE DIMENSIONS

Micro8  
DM SUFFIX  
CASE 846A-02  
ISSUE F

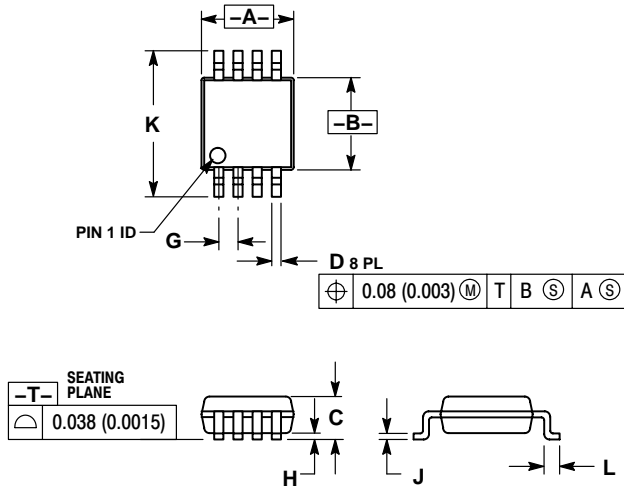

### NOTES:

1. DIMENSIONING AND TOLERANCING PER ANSI Y14.5M, 1982.
2. CONTROLLING DIMENSION: MILLIMETER.
3. DIMENSION A DOES NOT INCLUDE MOLD FLASH, PROTRUSIONS OR GATE BURRS. MOLD FLASH, PROTRUSIONS OR GATE BURRS SHALL NOT EXCEED 0.15 (0.006) PER SIDE.
4. DIMENSION B DOES NOT INCLUDE INTERLEAD FLASH OR PROTRUSION. INTERLEAD FLASH OR PROTRUSION SHALL NOT EXCEED 0.25 (0.010) PER SIDE.
5. 846A-01 OBSOLETE, NEW STANDARD 846A-02.

DIM	MILLIMETERS		INCHES	
	MIN	MAX	MIN	MAX
A	2.90	3.10	0.114	0.122
B	2.90	3.10	0.114	0.122
C	---	1.10	---	0.043
D	0.25	0.40	0.010	0.016
G	0.65 BSC		0.026 BSC	
H	0.05	0.15	0.002	0.006
J	0.13	0.23	0.005	0.009
K	4.75	5.05	0.187	0.199
L	0.40	0.70	0.016	0.028

Micro8 is a trademark of International Rectifier.

ON Semiconductor and are registered trademarks of Semiconductor Components Industries, LLC (SCILLC). SCILLC reserves the right to make changes without further notice to any products herein. SCILLC makes no warranty, representation or guarantee regarding the suitability of its products for any particular purpose, nor does SCILLC assume any liability arising out of the application or use of any product or circuit, and specifically disclaims any and all liability, including without limitation special, consequential or incidental damages. "Typical" parameters which may be provided in SCILLC data sheets and/or specifications can and do vary in different applications and actual performance may vary over time. All operating parameters, including "Typicals" must be validated for each customer application by customer's technical experts. SCILLC does not convey any license under its patent rights nor the rights of others. SCILLC products are not designed, intended, or authorized for use as components in systems intended for surgical implant into the body, or other applications intended to support or sustain life, or for any other application in which the failure of the SCILLC product could create a situation where personal injury or death may occur. Should Buyer purchase or use SCILLC products for any such unintended or unauthorized application, Buyer shall indemnify and hold SCILLC and its officers, employees, subsidiaries, affiliates, and distributors harmless against all claims, costs, damages, and expenses, and reasonable attorney fees arising out of, directly or indirectly, any claim of personal injury or death associated with such unintended or unauthorized use, even if such claim alleges that SCILLC was negligent regarding the design or manufacture of the part. SCILLC is an Equal Opportunity/Affirmative Action Employer. This literature is subject to all applicable copyright laws and is not for resale in any manner.

### PUBLICATION ORDERING INFORMATION

#### LITERATURE FULFILLMENT:

Literature Distribution Center for ON Semiconductor  
P.O. Box 61312, Phoenix, Arizona 85082-1312 USA  
Phone: 480-829-7710 or 800-344-3860 Toll Free USA/Canada  
Fax: 480-829-7709 or 800-344-3867 Toll Free USA/Canada  
Email: orderlit@onsemi.com

N. American Technical Support: 800-282-9855 Toll Free  
USA/Canada

Japan: ON Semiconductor, Japan Customer Focus Center  
2-9-1 Kamimeguro, Meguro-ku, Tokyo, Japan 153-0051  
Phone: 81-3-5773-3850

ON Semiconductor Website: <http://onsemi.com>

Order Literature: <http://www.onsemi.com/litorder>

For additional information, please contact your local Sales Representative.

## Looking for pricing, stock, or lifecycle information?

Click below to explore more details on WIN SOURCE:

 [View MC33565DR2G on WIN SOURCE](#)

 [ON Semiconductor](#) Information

## Optimize Your Supply Chain with WIN SOURCE Solutions

-  Global Sourcing Solution
-  Obsolete Management
-  Cost Control Management
-  Shortage Management
-  Alternative Solution
-  Excess Inventory Management