

# MGW1R5

MG W 1R5 24 12 -□

① ② ③ ④ ⑤ ⑥

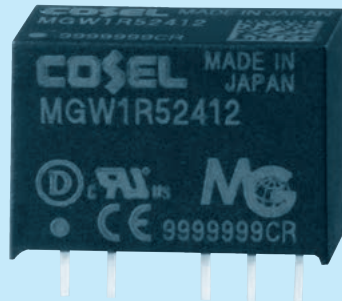

- ① Series name
- ② Dual output
- ③ Output wattage
- ④ Input voltage
- ⑤ Output voltage
- ⑥ Optional

MODEL	MGW1R50512	MGW1R50515	MGW1R51212	MGW1R51215	MGW1R52412	MGW1R52415	MGW1R54812	MGW1R54815
MAX OUTPUT WATTAGE[W]	1.56	1.50	1.56	1.50	1.56	1.50	1.56	1.50
DC OUTPUT	VOLTAGE[V] *1	±12 or +24	±15 or +30	±12 or +24	±15 or +30	±12 or +24	±15 or +30	±12 or +24
	CURRENT[A]	0.065	0.05	0.065	0.05	0.065	0.05	0.065

## SPECIFICATIONS

	MODEL	MGW1R50512	MGW1R50515	MGW1R51212	MGW1R51215	MGW1R52412	MGW1R52415	MGW1R54812	MGW1R54815	
INPUT	VOLTAGE[V]	DC4.5 - 9 (Surge voltage 12.5V, 100ms max)		DC9 - 18 (Surge voltage 25V, 100ms max)		DC18 - 36 (Surge voltage 50V, 100ms max)		DC36 - 76 (Surge voltage 100V, 100ms max)		
	CURRENT[A] *2	0.38typ	0.38typ	0.16typ	0.16typ	0.080typ	0.079typ	0.041typ	0.040typ	
	EFFICIENCY[%] *2	83typ	81typ	83typ	81typ	82typ	80typ	81typ	80typ	
OUTPUT	VOLTAGE[V]	±12 or +24	±15 or +30	±12 or +24	±15 or +30	±12 or +24	±15 or +30	±12 or +24	±15 or +30	
	CURRENT[A]	0.065	0.05	0.065	0.05	0.065	0.05	0.065	0.05	
	LINE REGULATION[mV]	60max	75max	60max	75max	60max	75max	60max	75max	
	LOAD REGULATION[mV]	*3	480max	600max	480max	600max	480max	600max	480max	600max
		*4	600max	750max	600max	750max	600max	750max	600max	750max
	RIPPLE[mVp-p] *5	150max	150max	150max	150max	150max	150max	150max	150max	
	RIPPLE NOISE[mVp-p] *5	200max	200max	200max	200max	200max	200max	200max	200max	
	TEMPERATURE REGULATION[mV]	-20 to +85°C	210max	260max	210max	260max	210max	260max	210max	260max
		-40 to +85°C	320max	390max	320max	390max	320max	390max	320max	390max
	DRIFT[mV] *6	48max	60max	48max	60max	48max	60max	48max	60max	
START-UP TIME[ms]	30max (Minimum input, I <sub>o</sub> =100%)									
OUTPUT VOLTAGE SETTING[V]	11.64 - 12.36	14.55 - 15.45	11.64 - 12.36	14.55 - 15.45	11.64 - 12.36	14.55 - 15.45	11.64 - 12.36	14.55 - 15.45		
PROTECTION CIRCUIT	OVERCURRENT PROTECTION	Works over 105% of rating and recovers automatically								
ISOLATION	INPUT-OUTPUT	DC1,500V or AC1,000V 1minute, Cutoff current=10mA, DC500V 1,000MΩ min (20±15°C)								
ENVIRONMENT	OPERATING TEMP., HUMID. AND ALTITUDE	-40 to +85°C, 20 to 95%RH (Non condensing) (Required derating), 5,000m (16,400feet) max								
	STORAGE TEMP., HUMID. AND ALTITUDE	-40 to +100°C, 20 to 95%RH (Non condensing), 9,000m (30,000feet) max								
	VIBRATION	10 - 55Hz 98.0m/s <sup>2</sup> (10G), 3minute period, 60minutes each along X, Y and Z axis								
	IMPACT	490.3m/s <sup>2</sup> (50G) 11ms, once each along X, Y and Z axis								
SAFETY	AGENCY APPROVALS	UL60950-1, C-UL, EN60950-1								
OTHERS	CASE SIZE/WEIGHT	17.0 X 12.0 X 8.5mm [0.67 X 0.48 X 0.34 inches] (W X H X D) / 4g max								
	COOLING METHOD	Convection/Forced air								

\*1 Single output +24V, +30V with no use of COM.  
 \*2 Rated input 5V, 12V, 24V or 48V DC I<sub>o</sub>=100%  
 \*3 Symmetrical loading from 20% to 100%.  
 \*4 Symmetrical loading from 0% to 100%.  
 \*5 Ripple and Ripple Noise is measured by using test board with ceramic capacitor 1μF at 50mm from output pins. (20MHz Oscilloscope)  
 \*6 Drift is the DC output accuracy for eight hours period after a half-hour warm-up at 25°C.  
 \* Parallel operation with other model is not possible.

External view

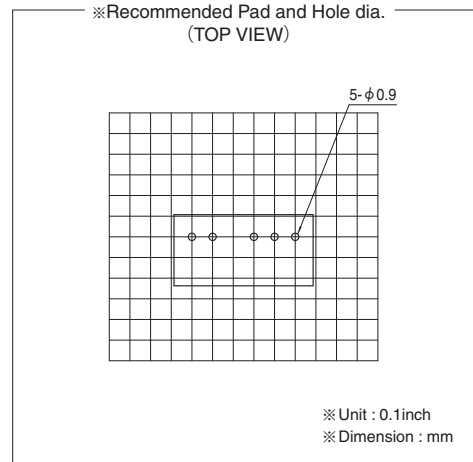
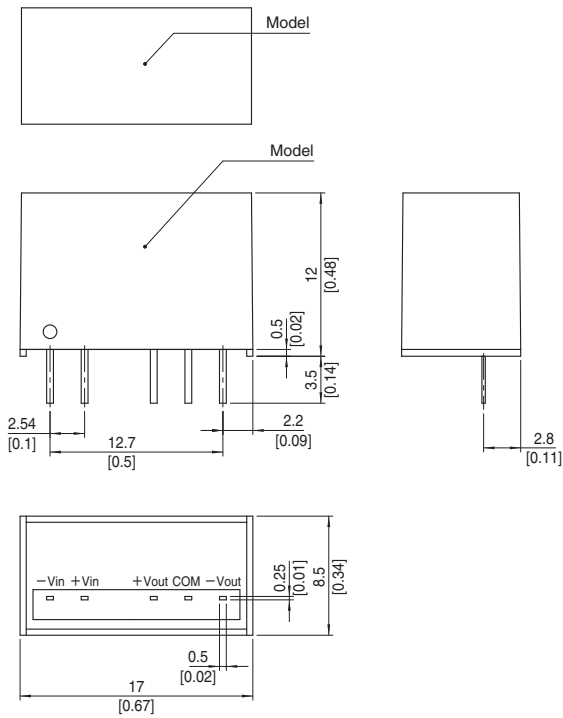

- ※ Tolerance  $\pm 0.5$  [ $\pm 0.02$ ]
- ※ Dimensions in mm, [ ]= inches
- ※ Pin terminal material : Copper
- ※ Planting treatment of terminal : Lead free plating
- ※ Case material : PBT
- ※ Weight 4g max

# MGW3

① MG ② W ③ 3 ④ 24 ⑤ 12 ⑥ -□

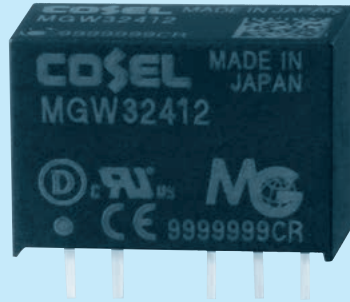

- ① Series name
- ② Dual output
- ③ Output wattage
- ④ Input voltage
- ⑤ Output voltage
- ⑥ Optional

MODEL	MGW30512	MGW30515	MGW31212	MGW31215	MGW32412	MGW32415	MGW34812	MGW34815
MAX OUTPUT WATTAGE[W]	3.12	3.00	3.12	3.00	3.12	3.00	3.12	3.00
DC OUTPUT	VOLTAGE[V] *1	±12 or +24	±15 or +30	±12 or +24	±15 or +30	±12 or +24	±15 or +30	±12 or +24
	CURRENT[A]	0.13	0.1	0.13	0.1	0.13	0.1	0.13

## SPECIFICATIONS

	MODEL	MGW30512	MGW30515	MGW31212	MGW31215	MGW32412	MGW32415	MGW34812	MGW34815	
INPUT	VOLTAGE[V]	DC4.5 - 9 (Surge voltage 12.5V, 100ms max)		DC9 - 18 (Surge voltage 25V, 100ms max)		DC18 - 36 (Surge voltage 50V, 100ms max)		DC36 - 76 (Surge voltage 100V, 100ms max)		
	CURRENT[A] *2	0.76typ	0.74typ	0.31typ	0.31typ	0.16typ	0.16typ	0.080typ	0.077typ	
	EFFICIENCY[%] *2	83typ	82typ	84typ	83typ	83typ	83typ	82typ	82typ	
OUTPUT	VOLTAGE[V]	±12 or +24	±15 or +30	±12 or +24	±15 or +30	±12 or +24	±15 or +30	±12 or +24	±15 or +30	
	CURRENT[A]	0.13	0.1	0.13	0.1	0.13	0.1	0.13	0.1	
	LINE REGULATION[mV]	60max	75max	60max	75max	60max	75max	60max	75max	
	LOAD REGULATION[mV]	*3	480max	600max	480max	600max	480max	600max	480max	600max
		*4	600max	750max	600max	750max	600max	750max	600max	750max
	RIPPLE[mVp-p] *5	150max	150max	150max	150max	150max	150max	150max	150max	
	RIPPLE NOISE[mVp-p] *5	200max	200max	200max	200max	200max	200max	200max	200max	
	TEMPERATURE REGULATION[mV]	-20 to +70°C	180max	220max	180max	220max	180max	220max	180max	220max
		-40 to +70°C	290max	340max	290max	340max	290max	340max	290max	340max
	DRIFT[mV] *6	48max	60max	48max	60max	48max	60max	48max	60max	
START-UP TIME[ms]	30max (Minimum input, I <sub>o</sub> =100%)									
OUTPUT VOLTAGE SETTING[V]	11.64 - 12.36	14.55 - 15.45	11.64 - 12.36	14.55 - 15.45	11.64 - 12.36	14.55 - 15.45	11.64 - 12.36	14.55 - 15.45		
PROTECTION CIRCUIT	OVERCURRENT PROTECTION	Works over 105% of rating and recovers automatically								
ISOLATION	INPUT-OUTPUT	DC1,500V or AC1,000V 1minute, Cutoff current=10mA, DC500V 1,000MΩ min (20±15°C)								
ENVIRONMENT	OPERATING TEMP., HUMID. AND ALTITUDE	-40 to +85°C, 20 to 95%RH (Non condensing) (Required derating), 5,000m (16,400feet) max								
	STORAGE TEMP., HUMID. AND ALTITUDE	-40 to +100°C, 20 to 95%RH (Non condensing), 9,000m (30,000feet) max								
	VIBRATION	10 - 55Hz 98.0m/s <sup>2</sup> (10G), 3minute period, 60minutes each along X, Y and Z axis								
	IMPACT	490.3m/s <sup>2</sup> (50G) 11ms, once each along X, Y and Z axis								
SAFETY	AGENCY APPROVALS	UL60950-1, C-UL, EN60950-1								
OTHERS	CASE SIZE/WEIGHT	17.0 X 12.0 X 8.5mm [0.67 X 0.48 X 0.34 inches] (W X H X D) / 4g max								
	COOLING METHOD	Convection/Forced air								

\*1 Single output +24V, +30V with no use of COM.  
 \*2 Rated input 5V, 12V, 24V or 48V DC I<sub>o</sub>=100%  
 \*3 Symmetrical loading from 20% to 100%.  
 \*4 Symmetrical loading from 0% to 100%.  
 \*5 Ripple and Ripple Noise is measured by using test board with ceramic capacitor 1μF at 50mm from output pins. (20MHz Oscilloscope)  
 \*6 Drift is the DC output accuracy for eight hours period after a half-hour warm-up at 25°C.  
 \* Parallel operation with other model is not possible.

External view

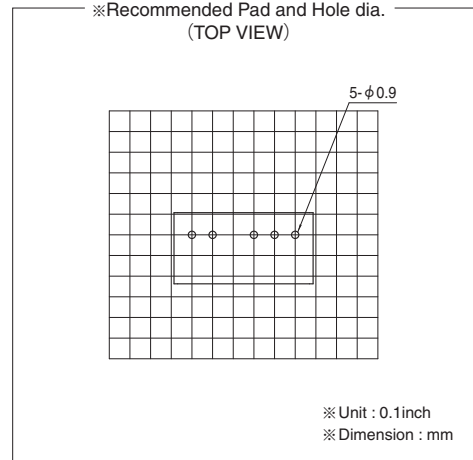
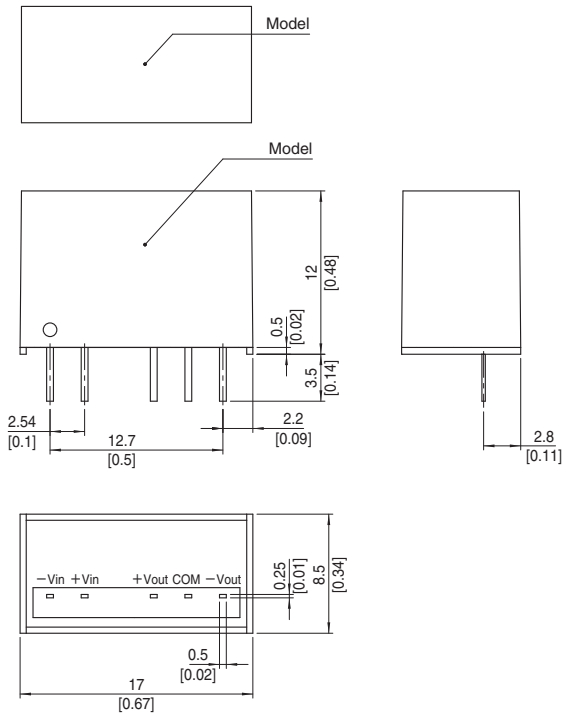

- ※ Tolerance  $\pm 0.5$  [ $\pm 0.02$ ]
- ※ Dimensions in mm, [ ]= inches
- ※ Pin terminal material : Copper
- ※ Planting treatment of terminal : Lead free plating
- ※ Case material : PBT
- ※ Weight 4g max

# MGW6

MG W 6 24 12 - □

① ② ③ ④ ⑤ ⑥

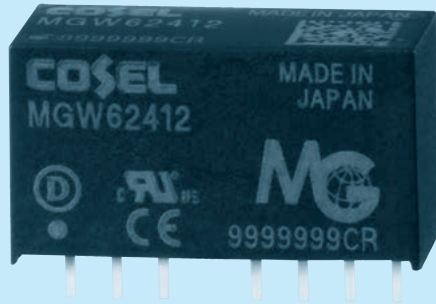

- ① Series name
- ② Dual output
- ③ Output wattage
- ④ Input voltage
- ⑤ Output voltage
- ⑥ Optional
- Y2: Output voltage adjustable (+10%, -5%)

MODEL	MGW60512	MGW60515	MGW61212	MGW61215	MGW62412	MGW62415	MGW64812	MGW64815
MAX OUTPUT WATTAGE[W]	6.00	6.00	6.00	6.00	6.00	6.00	6.00	6.00
DC OUTPUT	VOLTAGE[V] *1	±12 or +24	±15 or +30	±12 or +24	±15 or +30	±12 or +24	±15 or +30	±12 or +24
	CURRENT[A]	0.25	0.2	0.25	0.2	0.25	0.2	0.25

## SPECIFICATIONS

	MODEL	MGW60512	MGW60515	MGW61212	MGW61215	MGW62412	MGW62415	MGW64812	MGW64815	
INPUT	VOLTAGE[V]	DC4.5 - 9 (Surge voltage 12.5V, 100ms max)		DC9 - 18 (Surge voltage 25V, 100ms max)		DC18 - 36 (Surge voltage 50V, 100ms max)		DC36 - 76 (Surge voltage 100V, 100ms max)		
	CURRENT[A] *2	1.38typ	1.38typ	0.57typ	0.57typ	0.29typ	0.29typ	0.15typ	0.15typ	
	EFFICIENCY[%] *2	87typ	87typ	88typ	88typ	88typ	88typ	88typ	88typ	
OUTPUT	VOLTAGE[V]	±12 or +24	±15 or +30	±12 or +24	±15 or +30	±12 or +24	±15 or +30	±12 or +24	±15 or +30	
	CURRENT[A]	0.25	0.2	0.25	0.2	0.25	0.2	0.25	0.2	
	LINE REGULATION[mV]	60max	75max	60max	75max	60max	75max	60max	75max	
	LOAD REGULATION[mV]	*3	480max	600max	480max	600max	480max	600max	480max	600max
		*4	600max	750max	600max	750max	600max	750max	600max	750max
	RIPPLE[mVp-p]	Po=30% to	120max	120max	120max	120max	120max	120max	120max	120max
		*5 Po=0 to 30%	480max	480max	360max	360max	360max	360max	360max	360max
	RIPPLE NOISE[mVp-p]	Po=30% to	200max	200max	200max	200max	200max	200max	200max	200max
		*5 Po=0 to 30%	600max	600max	500max	500max	500max	500max	500max	500max
	TEMPERATURE REGULATION[mV]	-20 to +70°C	180max	220max	180max	220max	180max	220max	180max	220max
	-40 to +70°C	290max	340max	290max	340max	290max	340max	290max	340max	
DRIFT[mV] *6		48max	60max	48max	60max	48max	60max	48max	60max	
START-UP TIME[ms]		30max (Minimum input, Io=100%)								
OUTPUT VOLTAGE SETTING[V]		11.64 - 12.36	14.55 - 15.45	11.64 - 12.36	14.55 - 15.45	11.64 - 12.36	14.55 - 15.45	11.64 - 12.36	14.55 - 15.45	
PROTECTION CIRCUIT AND OTHERS	OVERCURRENT PROTECTION	Works over 105% of rating and recovers automatically								
	REMOTE ON/OFF	Provided (Negative logic L : ON, H : OFF)								
ISOLATION	INPUT-OUTPUT	DC1,500V or AC1,000V 1minute, Cutoff current=10mA, DC500V 1,000MΩ min (20±15°C)								
ENVIRONMENT	OPERATING TEMP., HUMID. AND ALTITUDE	-40 to +85°C, 20 to 95%RH (Non condensing) (Required derating), 5,000m (16,400feet) max								
	STORAGE TEMP., HUMID. AND ALTITUDE	-40 to +100°C, 20 to 95%RH (Non condensing), 9,000m (30,000feet) max								
	VIBRATION	10 - 55Hz 98.0m/s <sup>2</sup> (10G), 3minute period, 60minutes each along X, Y and Z axis								
	IMPACT	490.3m/s <sup>2</sup> (50G) 11ms, once each along X, Y and Z axis								
SAFETY	AGENCY APPROVALS	UL60950-1, C-UL, EN60950-1								
OTHERS	CASE SIZE/WEIGHT	22.0 X 12.0 X 9.5mm [0.87 X 0.48 X 0.38 inches] (W X H X D) / 7g max								
	COOLING METHOD	Convection/Forced air								

\*1 Single output +24V, +30V with no use of COM.  
 \*2 Rated input 5V, 12V, 24V or 48V DC Io=100%  
 \*3 Symmetrical loading from 20% to 100%.  
 \*4 Symmetrical loading from 0% to 100%.  
 \*5 Ripple and Ripple Noise is measured by using test board with ceramic capacitor 1μF at 50mm from output pins. (20MHz Oscilloscope). Po:Output wattage.  
 \*6 Drift is the DC output accuracy for eight hours period after a half-hour warm-up at 25°C.  
 \* Parallel operation with other model is not possible.

External view

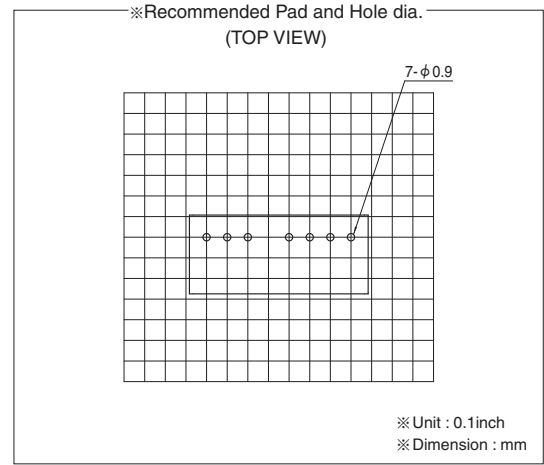
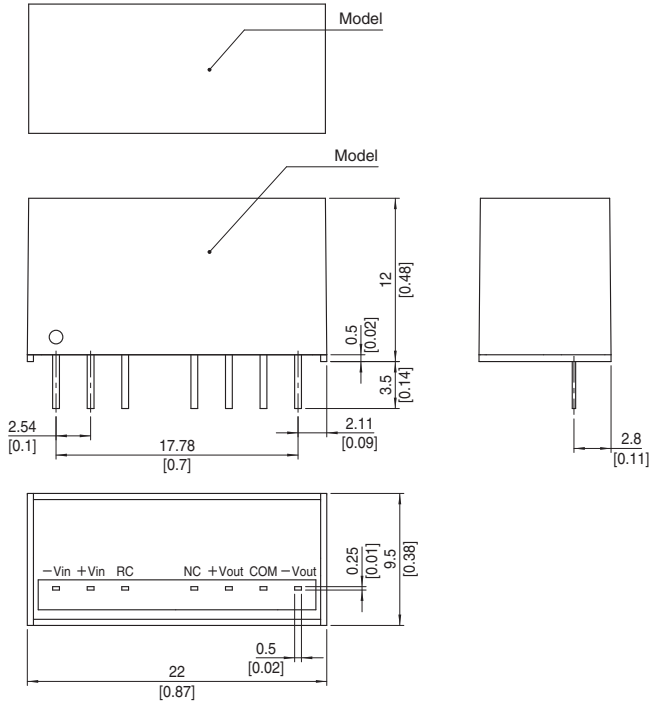

- ※ Tolerance  $\pm 0.5$  [ $\pm 0.02$ ]
- ※ Dimensions in mm, [ ]= inches
- ※ Pin terminal material : Copper
- ※ Planting treatment of terminal : Lead free plating
- ※ Case material : PBT
- ※ Weight 7g max

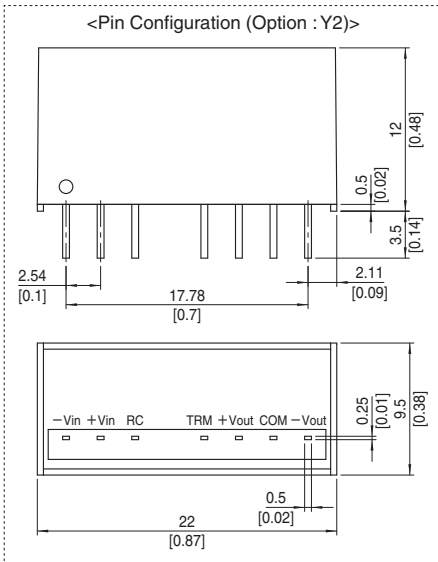

# MGW10

MG W 10 24 12 - □

① ② ③ ④ ⑤ ⑥

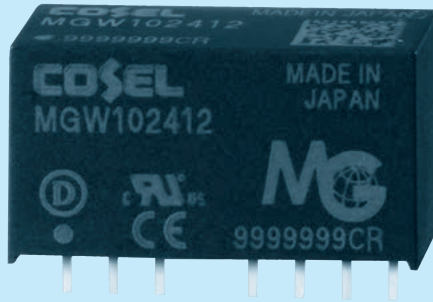

- ① Series name
- ② Dual output
- ③ Output wattage
- ④ Input voltage
- ⑤ Output voltage
- ⑥ Optional
- Y2: Output voltage adjustable (+10%, -5%)

MODEL	MGW100512	MGW100515	MGW101212	MGW101215	MGW102412	MGW102415	MGW104812	MGW104815	
MAX OUTPUT WATTAGE[W]	10.08	10.20	10.08	10.20	10.08	10.20	10.08	10.20	
DC OUTPUT	VOLTAGE[V] *1	±12 or +24	±15 or +30	±12 or +24	±15 or +30	±12 or +24	±15 or +30	±12 or +24	±15 or +30
	CURRENT[A]	0.42	0.34	0.42	0.34	0.42	0.34	0.42	0.34

## SPECIFICATIONS

	MODEL	MGW100512	MGW100515	MGW101212	MGW101215	MGW102412	MGW102415	MGW104812	MGW104815	
INPUT	VOLTAGE[V]	DC4.5 - 9 (Surge voltage 12.5V, 100ms max)		DC9 - 18 (Surge voltage 25V, 100ms max)		DC18 - 36 (Surge voltage 50V, 100ms max)		DC36 - 76 (Surge voltage 100V, 100ms max)		
	CURRENT[A] *2	2.38typ	2.40typ	0.97typ	0.97typ	0.49typ	0.49typ	0.24typ	0.25typ	
	EFFICIENCY[%] *2	85typ	85typ	87typ	88typ	87typ	88typ	88typ	88typ	
OUTPUT	VOLTAGE[V]	±12 or +24	±15 or +30	±12 or +24	±15 or +30	±12 or +24	±15 or +30	±12 or +24	±15 or +30	
	CURRENT[A]	0.42	0.34	0.42	0.34	0.42	0.34	0.42	0.34	
	LINE REGULATION[mV]	60max	75max	60max	75max	60max	75max	60max	75max	
	LOAD REGULATION[mV]	*3	480max	600max	480max	600max	480max	600max	480max	600max
		*4	600max	750max	600max	750max	600max	750max	600max	750max
	RIPPLE[mVp-p]	Po=30% to	120max	120max	120max	120max	120max	120max	120max	120max
		*5 Po=0 to 30%	480max	480max	360max	360max	360max	360max	360max	360max
	RIPPLE NOISE[mVp-p]	Po=30% to	200max	200max	200max	200max	200max	200max	200max	200max
		*5 Po=0 to 30%	600max	600max	500max	500max	500max	500max	500max	500max
	TEMPERATURE REGULATION[mV]	-20 to +50°C	150max	180max	150max	180max	150max	180max	150max	180max
	-40 to +50°C	240max	290max	240max	290max	240max	290max	240max	290max	
DRIFT[mV] *6		48max	60max	48max	60max	48max	60max	48max	60max	
START-UP TIME[ms]		30max (Minimum input, Io=100%)								
OUTPUT VOLTAGE SETTING[V]		11.64 - 12.36	14.55 - 15.45	11.64 - 12.36	14.55 - 15.45	11.64 - 12.36	14.55 - 15.45	11.64 - 12.36	14.55 - 15.45	
PROTECTION CIRCUIT AND OTHERS	OVERCURRENT PROTECTION	Works over 105% of rating and recovers automatically								
	REMOTE ON/OFF	Provided (Negative logic L : ON, H : OFF)								
ISOLATION	INPUT-OUTPUT	DC1,500V or AC1,000V 1minute, Cutoff current=10mA, DC500V 1,000MΩ min (20±15°C)								
ENVIRONMENT	OPERATING TEMP., HUMID. AND ALTITUDE	-40 to +85°C, 20 to 95%RH (Non condensing) (Required derating), 5,000m (16,400feet) max								
	STORAGE TEMP., HUMID. AND ALTITUDE	-40 to +100°C, 20 to 95%RH (Non condensing), 9,000m (30,000feet) max								
	VIBRATION	10 - 55Hz 98.0m/s <sup>2</sup> (10G), 3minute period, 60minutes each along X, Y and Z axis								
	IMPACT	490.3m/s <sup>2</sup> (50G) 11ms, once each along X, Y and Z axis								
SAFETY	AGENCY APPROVALS	UL60950-1, C-UL, EN60950-1								
OTHERS	CASE SIZE/WEIGHT	22.0 X 12.0 X 9.5mm [0.87 X 0.48 X 0.38 inches] (W X H X D) / 7g max								
	COOLING METHOD	Convection/Forced air								

- \*1 Single output +24V, +30V with no use of COM.
- \*2 Rated input 5V, 12V, 24V or 48V DC Io=100%
- \*3 Symmetrical loading from 20% to 100%.
- \*4 Symmetrical loading from 0% to 100%.
- \*5 Ripple and Ripple Noise is measured by using test board with ceramic capacitor 1μF at 50mm from output pins. (20MHz Oscilloscope). Po:Output wattage.
- \*6 Drift is the DC output accuracy for eight hours period after a half-hour warm-up at 25°C.
- \* Parallel operation with other model is not possible.

External view

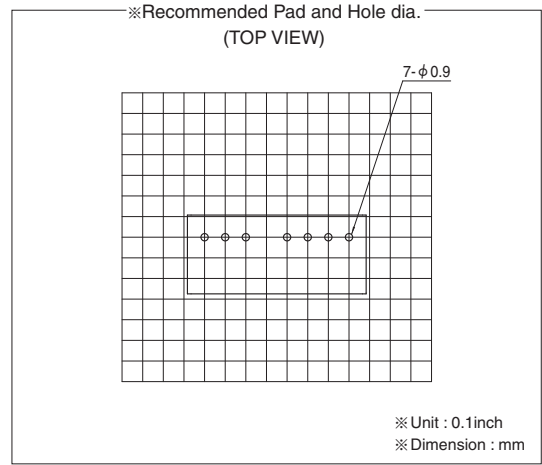
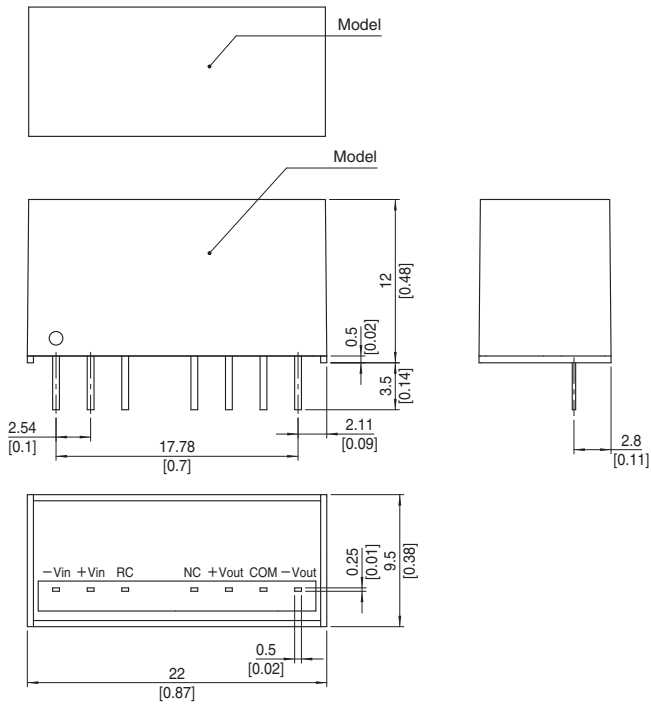

- ※ Tolerance  $\pm 0.5$  [ $\pm 0.02$ ]
- ※ Dimensions in mm, [ ]= inches
- ※ Pin terminal material : Copper
- ※ Planting treatment of terminal : Lead free plating
- ※ Case material : PBT
- ※ Weight 7g max

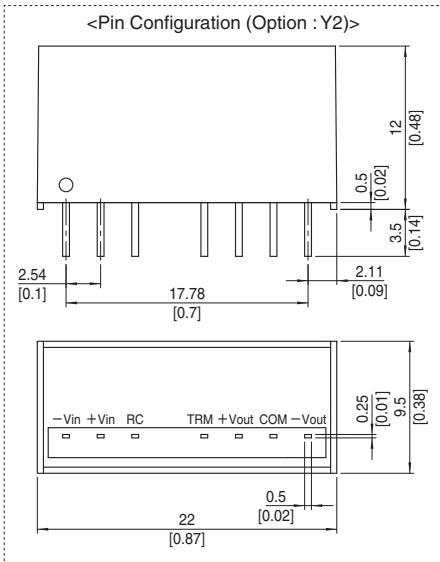

# MGW15

MG W 15 24 05 - □

① ② ③ ④ ⑤ ⑥

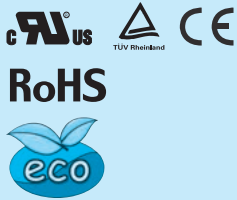

- ① Series name
- ② Dual output
- ③ Output wattage
- ④ Input voltage
- ⑤ Output voltage
- ⑥ Optional
- G: Capacitor between Input and Output is removed.
- R: with Remote ON/OFF (Positive logic control)

MODEL	MGW151205	MGW151212	MGW151215	MGW152405	MGW152412	MGW152415	MGW154805	MGW154812	MGW154815	
MAX OUTPUT WATTAGE[W]	15	15.6	15	15	15.6	15	15	15.6	15	
DC OUTPUT	VOLTAGE[V] *1	±5 or +10	±12 or +24	±15 or +30	±5 or +10	±12 or +24	±15 or +30	±5 or +10	±12 or +24	±15 or +30
	CURRENT[A]	1.5	0.65	0.5	1.5	0.65	0.5	1.5	0.65	0.5

## SPECIFICATIONS

	MODEL	MGW151205	MGW151212	MGW151215	MGW152405	MGW152412	MGW152415	MGW154805	MGW154812	MGW154815	
INPUT	VOLTAGE[V]	DC9 - 18			DC18 - 36			DC36 - 76			
	CURRENT[A] *2	1.48typ	1.49typ	1.42typ	0.74typ	0.74typ	0.70typ	0.37typ	0.37typ	0.35typ	
	EFFICIENCY[%] *2	84typ	87typ	88typ	84typ	88typ	89typ	84typ	89typ	89typ	
OUTPUT	VOLTAGE[V]	±5(+10)	±12(+24)	±15(+30)	±5(+10)	±12(+24)	±15(+30)	±5(+10)	±12(+24)	±15(+30)	
	CURRENT[A]	1.5	0.65	0.5	1.5	0.65	0.5	1.5	0.65	0.5	
	LINE REGULATION[mV]	40max	60max	75max	40max	60max	75max	40max	60max	75max	
	LOAD REGULATION[mV]	*3	500max *5	600max	750max	500max *5	600max	750max	500max *5	600max	750max
		*4	250max	480max	600max	250max	480max	600max	250max	480max	600max
	RIPPLE[mVp-p] *6	-20 to +60°C	100max	100max	100max	100max	100max	100max	100max	100max	100max
		-40 to -20°C	120max	120max	120max	120max	120max	120max	120max	120max	120max
	RIPPLE NOISE[mVp-p] *6	-20 to +60°C	100max	100max	100max	100max	100max	100max	100max	100max	100max
		-40 to -20°C	150max	150max	150max	150max	150max	150max	150max	150max	150max
	TEMPERATURE REGULATION[mV]	-20 to +60°C	50max	150max	180max	50max	150max	180max	50max	150max	180max
-40 to +60°C		80max	240max	290max	80max	240max	290max	80max	240max	290max	
DRIFT[mV] *7	50max	50max	60max	50max	50max	60max	50max	50max	60max		
START-UP TIME[ms]	30max (Minimum input, lo=100%)										
OUTPUT VOLTAGE SETTING[V]*8	4.935 - 5.240	11.765 - 12.492	14.602 - 15.505	4.935 - 5.240	11.765 - 12.492	14.602 - 15.505	4.935 - 5.240	11.765 - 12.492	14.602 - 15.505		
PROTECTION CIRCUIT AND OTHERS	OVERCURRENT PROTECTION	Works over 105% of rating and recovers automatically									
	REMOTE ON/OFF	Provided (Negative logic L:ON, H:OFF)									
ISOLATION	INPUT-OUTPUT	DC1,500V 1minute, Cutoff current = 10mA, DC500V 1,000MΩ min (20±15°C)									
	INPUT-CASE	DC1,000V 1minute, Cutoff current = 10mA, DC500V 1,000MΩ min (20±15°C)									
	OUTPUT-CASE	DC1,000V 1minute, Cutoff current = 10mA, DC500V 1,000MΩ min (20±15°C)									
ENVIRONMENT	OPERATING TEMP., HUMID. AND ALTITUDE	-40 to +85°C, 20 to 95%RH (Non condensing) (Required Derating), 3,000m (10,000feet) max									
	STORAGE TEMP., HUMID. AND ALTITUDE	-40 to +100°C, 20 to 95%RH (Non condensing), 9,000m (30,000feet) max									
	VIBRATION	10 - 55Hz, 98.0m/s <sup>2</sup> (10G), 3minutes period, 60minutes each along X, Y and Z axis									
	IMPACT	490.3m/s <sup>2</sup> (50G), 11ms, once each along X, Y and Z axis									
SAFETY	AGENCY APPROVALS	UL60950-1, C-UL, EN60950-1									
OTHERS	CASE SIZE/WEIGHT	25.4 × 9.9 × 25.4mm [1 × 0.39 × 1 inches] (W × H × D) / 20g max									
	COOLING METHOD	Convection/Forced air									

\*1 Single output +10V, +24V, +30V with no use of COM.  
 \*2 Rated input 12V, 24V or 48V lo=100%  
 \*3 An output load is 100%, the other load is 5% to 100%.  
 \*4 An output load is 100%, the other load is 20% to 100%.  
 \*5 Refer to the instruction manual 11.  
 \*6 Ripple and Ripple Noise is measured by using test board with ceramic capacitor 22μF at 50mm from output pins. (20MHz Oscilloscope)  
 \*7 Drift is the DC output accuracy for eight hours period after a half-hour warm-up at 25°C.

\*8 Rated input voltage (DC12V, DC24V, DC48V), rated output wattage, ambient temperature at 25°C.  
 \* Parallel operation with other model is not possible.

External view

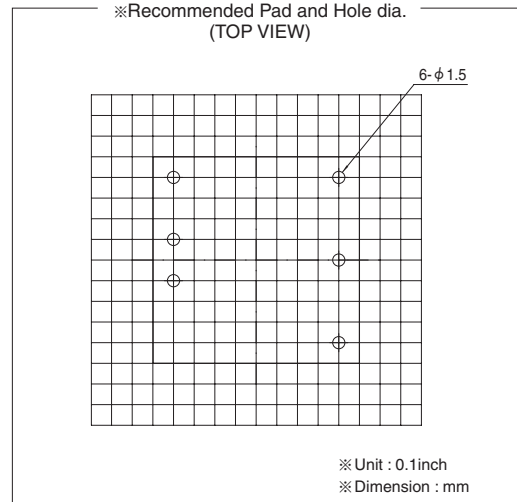
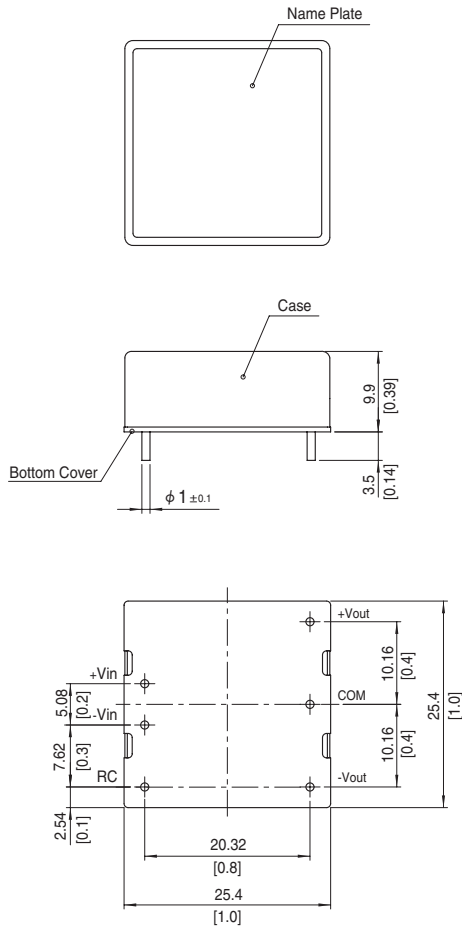

- ※ Tolerance  $\pm 0.5$  [ $\pm 0.02$ ]
- ※ Dimensions in mm, [ ]=inches
- ※ Pin terminal material : Copper
- ※ Plating treatment of terminal : Lead free plating
- ※ Case material : Brass
- ※ Plating treatment of case : Nickel plating
- ※ Bottom Cover : FR4 (t=0.6) [t=0.024]
- ※ Please keep enough creepage distance with the pattern on PCB and other components.
- ※ Weight 20g max

# MGW30

MG W 30 24 05 - □

① ② ③ ④ ⑤ ⑥



- ① Series name
- ② Dual output
- ③ Output wattage
- ④ Input voltage
- ⑤ Output voltage
- ⑥ Optional
- G: Capacitor between Input and Output is removed.
- R: with Remote ON/OFF (Positive logic control)

MODEL	MGW301205	MGW301212	MGW301215	MGW302405	MGW302412	MGW302415	MGW304805	MGW304812	MGW304815	
MAX OUTPUT WATTAGE[W]	25	30	30	25	30	30	25	30	30	
DC OUTPUT	VOLTAGE[V] *1	±5 or +10	±12 or +24	±15 or +30	±5 or +10	±12 or +24	±15 or +30	±5 or +10	±12 or +24	±15 or +30
	CURRENT[A]	2.5	1.25	1	2.5	1.25	1	2.5	1.25	1

## SPECIFICATIONS

	MODEL	MGW301205	MGW301212	MGW301215	MGW302405	MGW302412	MGW302415	MGW304805	MGW304812	MGW304815	
INPUT	VOLTAGE[V]	DC9 - 18			DC18 - 36			DC36 - 76			
	CURRENT[A] *2	2.42typ	2.78typ	2.78typ	1.20typ	1.38typ	1.38typ	0.60typ	0.70typ	0.70typ	
	EFFICIENCY[%] *2	86typ	90typ	90typ	87typ	91typ	91typ	87typ	90typ	90typ	
OUTPUT	VOLTAGE[V]	±5(+10)	±12(+24)	±15(+30)	±5(+10)	±12(+24)	±15(+30)	±5(+10)	±12(+24)	±15(+30)	
	CURRENT[A]	2.5	1.25	1	2.5	1.25	1	2.5	1.25	1	
	LINE REGULATION[mV]	40max	60max	75max	40max	60max	75max	40max	60max	75max	
	LOAD REGULATION[mV]	*3	500max *5	600max	750max	500max *5	600max	750max	500max *5	600max	750max
		*4	250max	480max	600max	250max	480max	600max	250max	480max	600max
	RIPPLE[mVp-p] *6	-20 to +60°C	100max	100max	100max	100max	100max	100max	100max	100max	100max
		-40 to -20°C	120max	120max	120max	120max	120max	120max	120max	120max	120max
	RIPPLE NOISE[mVp-p] *6	-20 to +60°C	100max	100max	100max	100max	100max	100max	100max	100max	100max
		-40 to -20°C	150max	150max	150max	150max	150max	150max	150max	150max	150max
	TEMPERATURE REGULATION[mV]	-20 to +60°C	50max	150max	180max	50max	150max	180max	50max	150max	180max
-40 to +60°C		80max	240max	290max	80max	240max	290max	80max	240max	290max	
DRIFT[mV] *7	50max	50max	60max	50max	50max	60max	50max	50max	60max		
START-UP TIME[ms]	30max (Minimum input, Io=100%)										
OUTPUT VOLTAGE SETTING[V]*8	4.935 - 5.240	11.765 - 12.492	14.602 - 15.505	4.935 - 5.240	11.765 - 12.492	14.602 - 15.505	4.935 - 5.240	11.765 - 12.492	14.602 - 15.505		
PROTECTION CIRCUIT AND OTHERS	OVERCURRENT PROTECTION	Works over 105% of rating and recovers automatically									
	OVERVOLTAGE PROTECTION	Works over 120 to 160% of rating (Total of +V and -V)									
	REMOTE ON/OFF	Provided (Negative logic L:ON, H:OFF)									
ISOLATION	INPUT-OUTPUT	DC1,500V 1minute, Cutoff current = 10mA, DC500V 1,000MΩ min (20±15°C)									
	INPUT-CASE	DC1,000V 1minute, Cutoff current = 10mA, DC500V 1,000MΩ min (20±15°C)									
	OUTPUT-CASE	DC1,000V 1minute, Cutoff current = 10mA, DC500V 1,000MΩ min (20±15°C)									
ENVIRONMENT	OPERATING TEMP., HUMID. AND ALTITUDE	-40 to +85°C, 20 to 95%RH (Non condensing) (Required Derating), 3,000m (10,000feet) max									
	STORAGE TEMP., HUMID. AND ALTITUDE	-40 to +100°C, 20 to 95%RH (Non condensing), 9,000m (30,000feet) max									
	VIBRATION	10 - 55Hz, 98.0m/s <sup>2</sup> (10G), 3minutes period, 60minutes each along X, Y and Z axis									
	IMPACT	490.3m/s <sup>2</sup> (50G), 11ms, once each along X, Y and Z axis									
SAFETY	AGENCY APPROVALS	UL60950-1, C-UL, EN60950-1									
OTHERS	CASE SIZE/WEIGHT	25.4 X 9.9 X 50.8mm [1 X 0.39 X 2 inches] (W X H X D) / 40g max									
	COOLING METHOD	Convection/Forced air									

\*1 Single output +10V, +24V, +30V with no use of COM.

\*2 Rated input 12V, 24V or 48V DC Io=100%

\*3 Symmetrical loading from 5% to 100%.

\*4 Symmetrical loading from 20% to 100%.

\*5 Refer to the instruction manual 11.

\*6 Ripple and Ripple Noise is measured by using test board with ceramic capacitor 22μF at 50mm from output pins. (20MHz Oscilloscope)

\*7 Drift is the DC output accuracy for eight hours period after a half-hour warm-up at 25°C.

\*8 Rated input voltage (DC12V, DC24V, DC48V), rated output wattage, ambient temperature at 25°C.

\* Parallel operation with other model is not possible.

External view

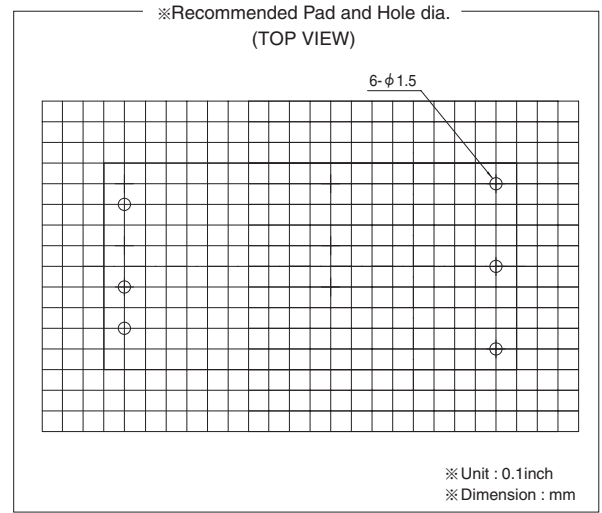
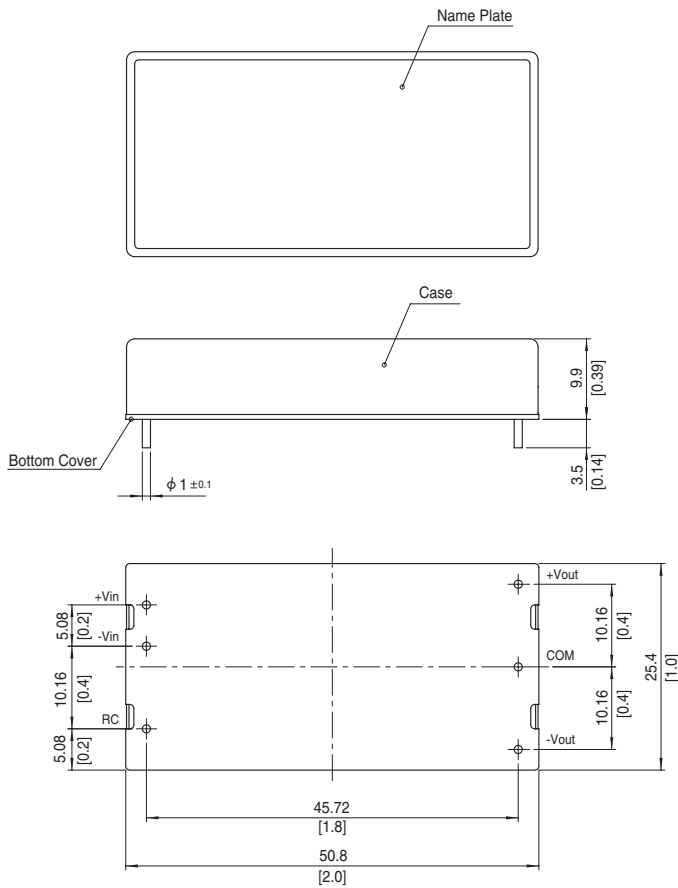

- ※ Tolerance  $\pm 0.5$  [ $\pm 0.02$ ]
- ※ Dimensions in mm, [ ]=inches
- ※ Pin terminal material : Copper
- ※ Plating treatment of terminal : Lead free plating
- ※ Case material : Brass
- ※ Plating treatment of case : Nickel plating
- ※ Bottom Cover : FR4 (t=0.6) [t=0.024]
- ※ Please keep enough creepage distance with the pattern on PCB and other components.
- ※ Weight 40g max

## Looking for pricing, stock, or lifecycle information?

Click below to explore more details on WIN SOURCE:

- ⊖ [View MGW304805 on WIN SOURCE](#)
- ⊖ [Cosel USA, Inc. Information](#)

## Optimize Your Supply Chain with WIN SOURCE Solutions

- ✓ Global Sourcing Solution
- ✓ Obsolete Management
- ✓ Cost Control Management
- ✓ Shortage Management
- ✓ Alternative Solution
- ✓ Excess Inventory Management