8 MHz 400 mA Internal Inductor Buck Regulator with HyperLight Load[®]

Features

- Internal Inductor
 - Simplifies Design to Two External Capacitors
- Input Voltage: 2.7V to 5.5V
- Output Voltage Accuracy of $\pm 2.5\%$ over Temperature
- 400 mA Output Current
- Efficiency up to 78% at 1 mA
- 21 μA Typical Quiescent Current
- Up to 8 MHz PWM Operation in Continuous Mode
- Ultra-Fast Transient Response
- Low Voltage Output Ripple
 - 30 mV_{PP} Ripple in HyperLight Load[®] Mode
 - 7 mV Output Voltage Ripple in Full PWM Mode
- Fully Integrated MOSFET Switches
- 0.01 μA Shutdown Current
- Thermal Shutdown and Current-Limit Protection
- Fixed and Adjustable Output Voltage Options Available (0.7V to 3.6V)
- 2.5 mm x 2.0 mm 10-Lead HJDFN Package
- -40°C to $+125^{\circ}\text{C}$ Junction Temperature Range

Applications

- Mobile Handsets
- Portable Media/MP3 Players
- Portable Navigation Devices (GPS)
- WiFi/WiMax/WiBro Modules
- Digital Cameras
- Wireless LAN Cards
- USB-Powered Devices
- Portable Applications

General Description

The MIC33030 is a high-efficiency, 8 MHz, 400 mA synchronous buck regulator with an internal inductor and HyperLight Load[®] mode. HyperLight Load[®] provides very high efficiency at light loads and ultra-fast transient response that is perfectly suited for supplying processor core voltages. An additional benefit of this proprietary architecture is the very low output ripple voltage throughout the entire load range with the use of small output capacitors. The tiny 2.5 mm x 2.0 mm HJDFN package saves precious board space and requires only two external capacitors.

The MIC33030 is designed for use with tiny output capacitors as small as 2.2 μF . This gives the MIC33030 the ease of use of an LDO with the efficiency of a HyperLight Load[®] DC converter.

The MIC33030 achieves efficiency in HyperLight Load[®] mode as high as 78% at 1 mA, with a very low quiescent current of 21 μA . At higher loads, the MIC33030 provides a constant switching frequency up to 8 MHz.

The MIC33030 is available in a 10-pin 2.5 mm x 2.0 mm HJDFN package with an operating junction temperature range of -40°C to $+125^{\circ}\text{C}$.

MIC33030

Typical Application Circuits

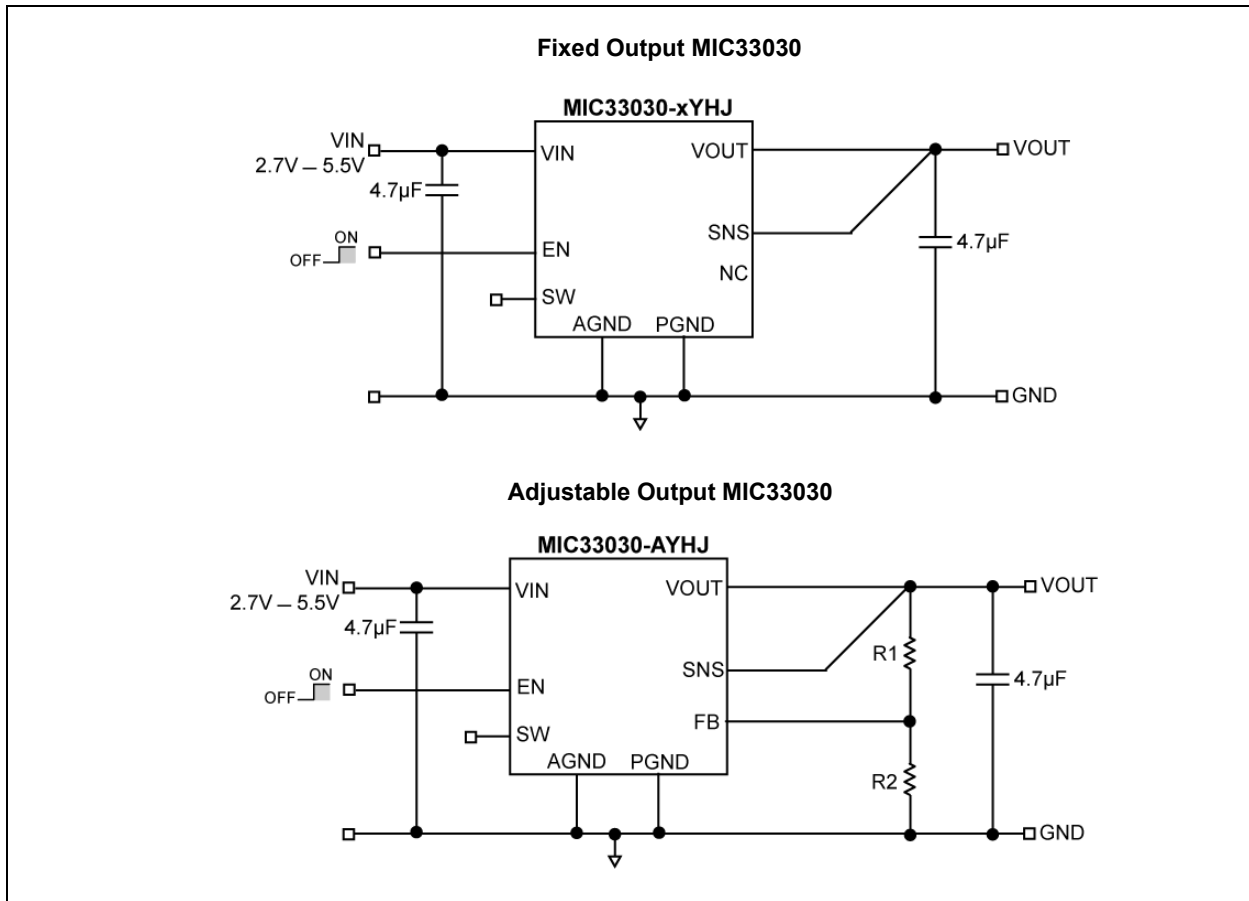

Package Types

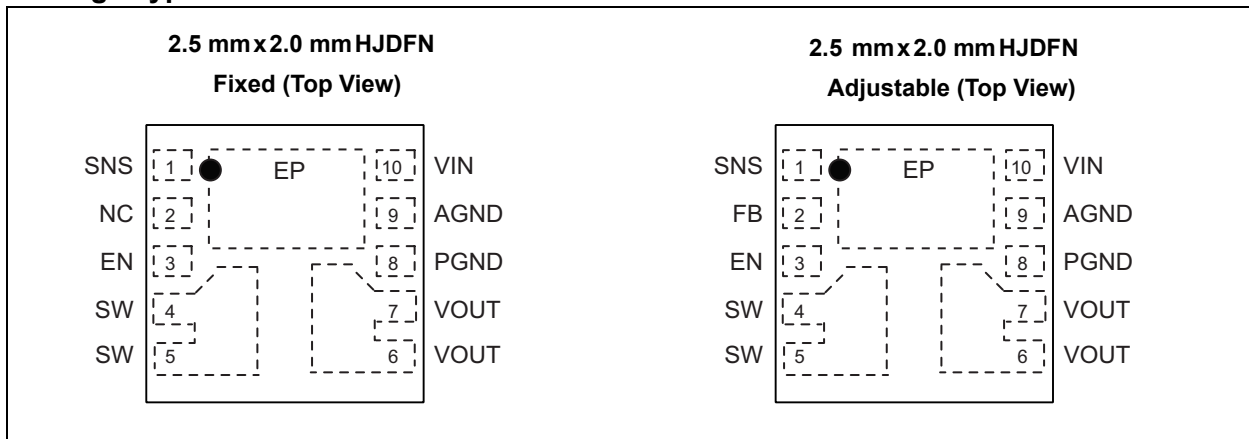

Functional Block Diagrams

Simplified MIC33030 Fixed Functional Block Diagram

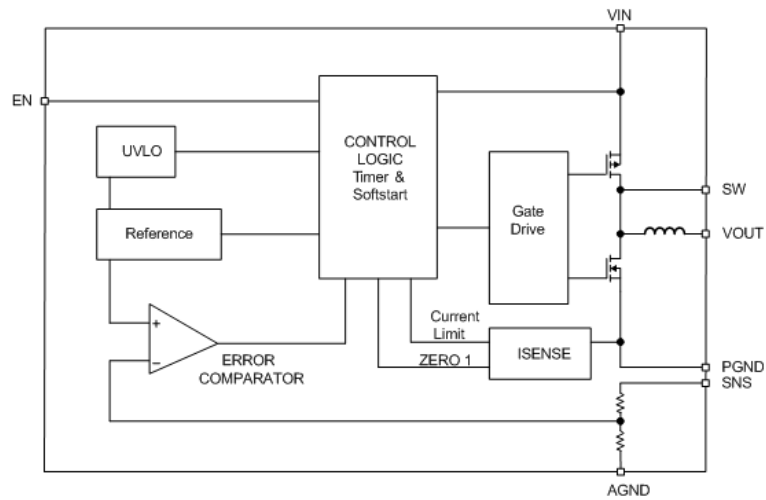

Simplified MIC33030 Adjustable Functional Block Diagram

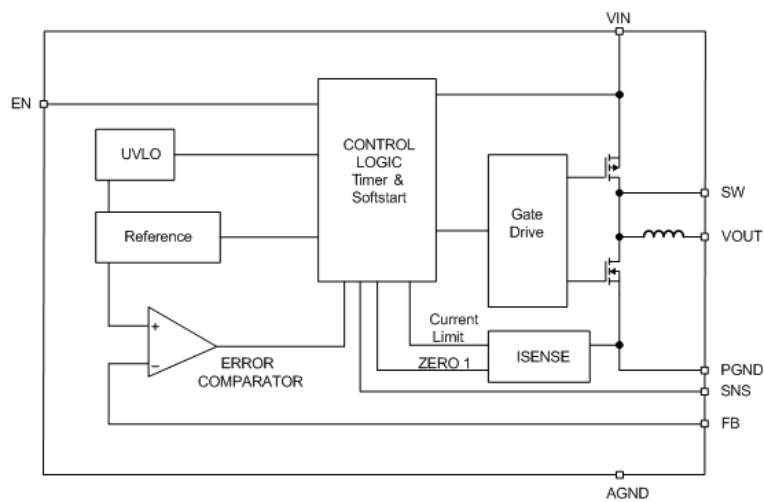

MIC33030

1.0 ELECTRICAL CHARACTERISTICS

Absolute Maximum Ratings †

Supply Voltage (V_{IN}).....	-0.3V to +6V
Sense (V_{SNS}).....	-0.3V to +6V
Output Switch Voltage.....	-0.3V to +6V
Enable Input Voltage (V_{EN}).....	-0.3V to V_{IN}
ESD Rating (Note 1).....	ESD Sensitive

Operating Ratings ‡

Supply Voltage (V_{IN}).....	+2.7V to +5.5V
Enable Input Voltage (V_{EN}).....	0V to V_{IN}
Output Voltage (V_{OUT}).....	+0.7V to +3.6V

† **Notice:** Stresses above those listed under “Absolute Maximum Ratings” may cause permanent damage to the device. This is a stress rating only and functional operation of the device at those or any other conditions above those indicated in the operational sections of this specification is not intended. Exposure to maximum rating conditions for extended periods may affect device reliability. Specifications are for packaged product only.

‡ **Notice:** The device is not guaranteed to function outside its operating ratings.

Note 1: Devices are ESD sensitive. Handling precautions are recommended. Human body model, 1.5 k Ω in series with 100 pF.

TABLE 1-1: ELECTRICAL CHARACTERISTICS

Electrical Characteristics: $T_A = 25^\circ\text{C}$, $V_{IN} = V_{EN} = 3.6\text{V}$; $C_{OUT} = 4.7\mu\text{F}$; **Bold** values indicate $-40^\circ\text{C} \leq T_J \leq +125^\circ\text{C}$; unless otherwise specified. Specification for packaged product only.

Parameter	Symbol	Min.	Typ.	Max.	Units	Conditions
Supply Voltage Range	—	2.7	—	5.5	V	—
Undervoltage Lockout Threshold	—	2.45	2.55	2.65	V	Turn-On
Under-Voltage Lockout Hysteresis	—	—	100	—	mV	—
Quiescent Current	—	—	21	35	μA	$I_{OUT} = 0\text{ mA}$, $SNS > 1.2 * V_{OUT(NOM)}$
Shutdown Current	—	—	0.01	4	μA	$V_{EN} = 0\text{V}$; $V_{IN} = 5.5\text{V}$
Output Voltage Accuracy	—	-2.5	—	+2.5	%	$V_{IN} = 3.6\text{V}$; $I_{LOAD} = 20\text{ mA}$
Feedback Voltage	—	—	0.62	—	V	Adjustable Option Only
Current-Limit	—	0.41	0.7	1	A	$SNS = 0.9 * V_{OUT(NOM)}$
Output Voltage Line Regulation	—	—	0.5	—	%/V	$V_{IN} = 3.0\text{V}$ to 5.5V , $V_{OUT} = 1.2\text{V}$, $I_{LOAD} = 20\text{ mA}$,
Output Voltage Load Regulation	—	—	0.7	—	%	$20\text{ mA} < I_{LOAD} < 400\text{ mA}$, $V_{OUT} = 1.2\text{V}$, $V_{IN} = 3.6\text{V}$
PWM Switch On-Resistance	—	—	0.65	—	Ω	$I_{SW} = 100\text{ mA PMOS}$
	—	—	0.8	—		$I_{SW} = -100\text{ mA NMOS}$
Maximum Frequency	—	—	8	—	MHz	$I_{OUT} = 120\text{ mA}$
Soft Start Time	—	—	100	—	μs	$V_{OUT} = 90\%$
Enable Threshold	—	0.5	0.9	1.2	V	—
Enable Hysteresis	—	—	35	—	mV	—
Enable Input Current	—	—	0.1	2	μA	—
Over Temperature Shutdown	—	—	160	—	$^\circ\text{C}$	—
Over Temperature Shutdown Hysteresis	—	—	20	—	$^\circ\text{C}$	—

TEMPERATURE SPECIFICATIONS (Note 1)

Parameters	Sym.	Min.	Typ.	Max.	Units	Conditions
Temperature Ranges						
Junction Operating Temperature Range	T_J	-40	—	+125	°C	—
Storage Temperature Range	T_S	-65	—	+150	°C	—
Package Thermal Resistances						
Thermal Resistance HJDFN 2.5 mm x 2.0 mm	θ_{JA}	—	76	—	°C/W	—
Thermal Resistance HJDFN 2.5 mm x 2.0 mm	θ_{JC}	—	45	—	°C/W	—

Note 1: The maximum allowable power dissipation is a function of ambient temperature, the maximum allowable junction temperature and the thermal resistance from junction to air (i.e., T_A , T_J , θ_{JA}). Exceeding the maximum allowable power dissipation will cause the device operating junction temperature to exceed the maximum +125°C rating. Sustained junction temperatures above +125°C can impact the device reliability.

MIC33030

2.0 TYPICAL PERFORMANCE CURVES

Note: The graphs and tables provided following this note are a statistical summary based on a limited number of samples and are provided for informational purposes only. The performance characteristics listed herein are not tested or guaranteed. In some graphs or tables, the data presented may be outside the specified operating range (e.g., outside specified power supply range) and therefore outside the warranted range.

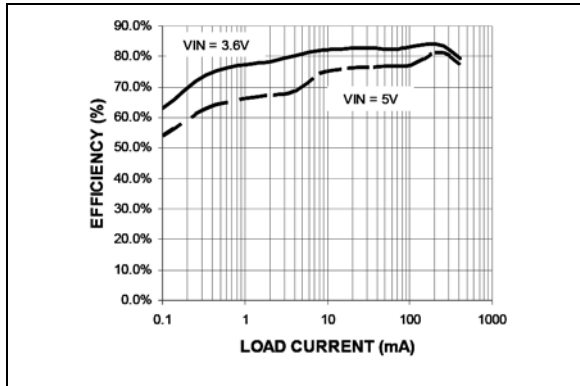

FIGURE 2-1: Efficiency vs. Load ($V_{OUT} = 2.5V$).

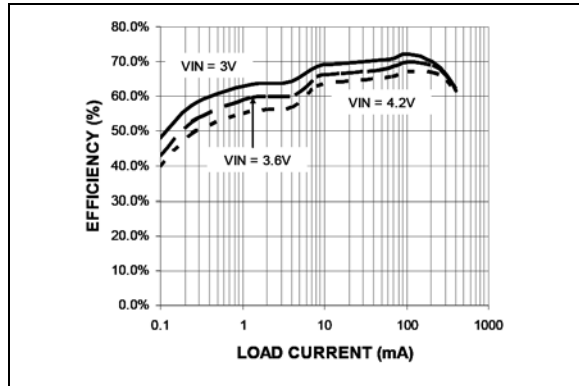

FIGURE 2-4: Efficiency vs. Load ($V_{OUT} = 1.2V$).

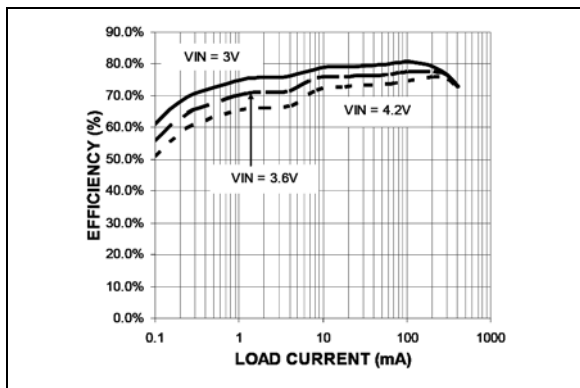

FIGURE 2-2: Efficiency vs. Load ($V_{OUT} = 1.8V$).

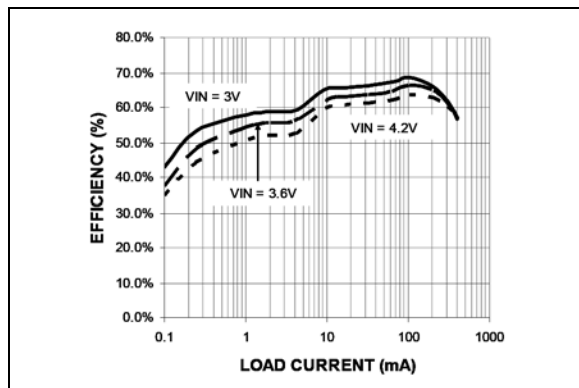

FIGURE 2-5: Efficiency vs. Load ($V_{OUT} = 1V$).

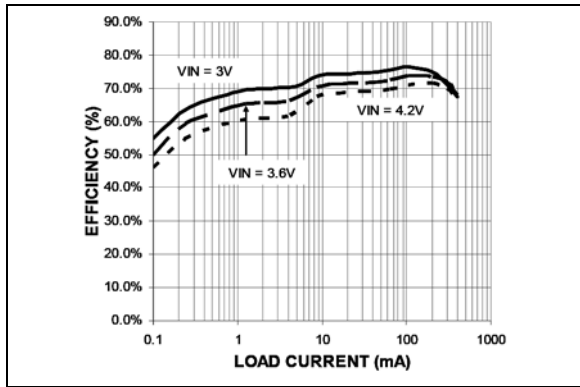

FIGURE 2-3: Efficiency vs. Load ($V_{OUT} = 1.5V$).

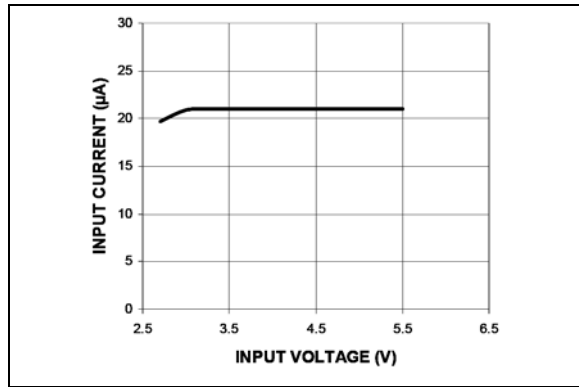

FIGURE 2-6: Quiescent Current vs. Input Voltage (Not Switching).

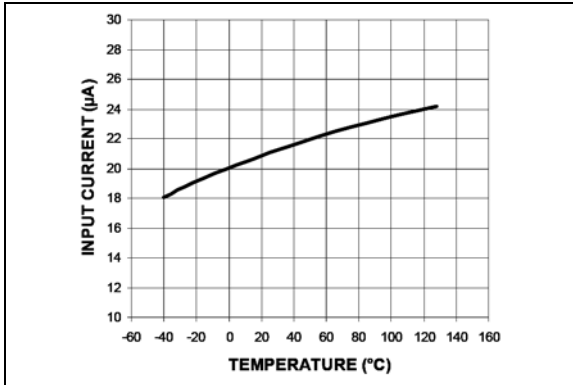

FIGURE 2-7: Quiescent Current vs. Temperature (Not Switching).

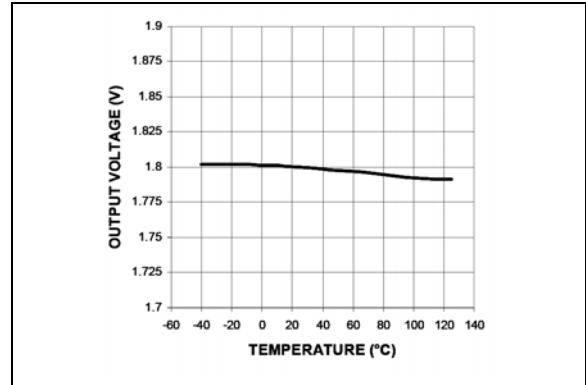

FIGURE 2-10: Output Voltage vs. Temperature.

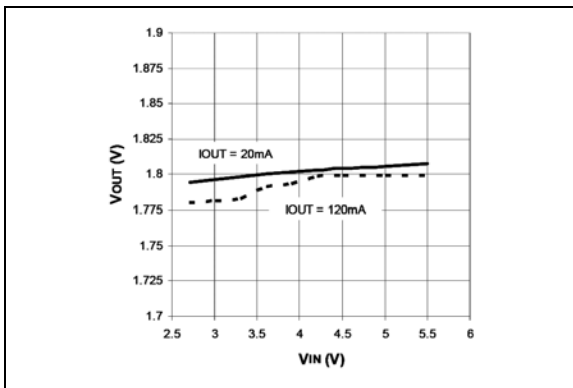

FIGURE 2-8: Output Voltage vs. Input Voltage.

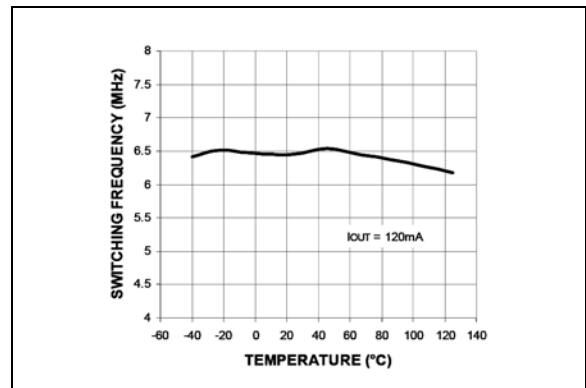

FIGURE 2-11: Switching Frequency vs. Temperature.

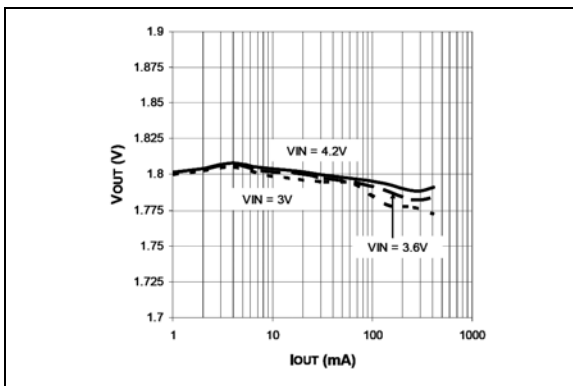

FIGURE 2-9: Output Voltage vs. Output Current.

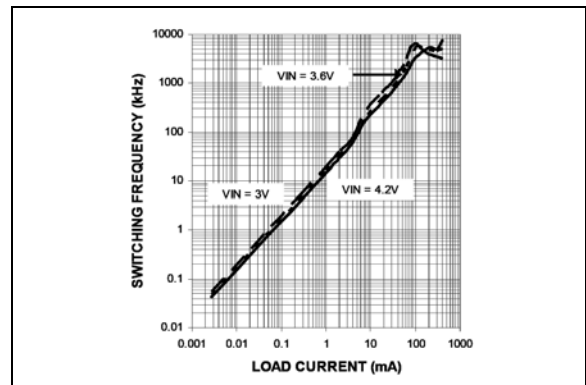

FIGURE 2-12: Switching Frequency vs. Load Current.

MIC33030

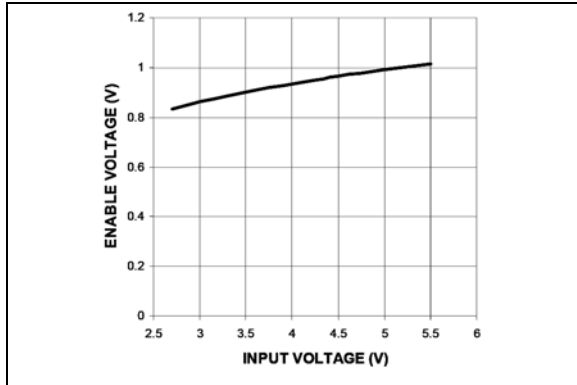

FIGURE 2-13: Enable (ON) Voltage vs. Input Voltage.

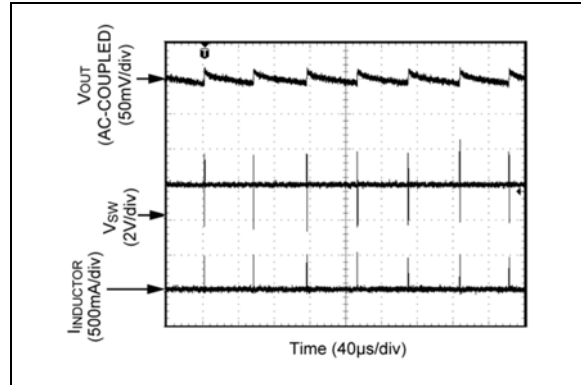

FIGURE 2-16: Switching Waveform - Discontinuous Mode $I_{OUT} = 1\text{ mA}$.

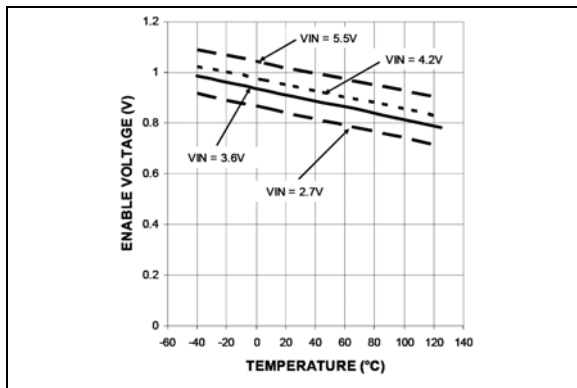

FIGURE 2-14: Enable Voltage vs. Temperature.

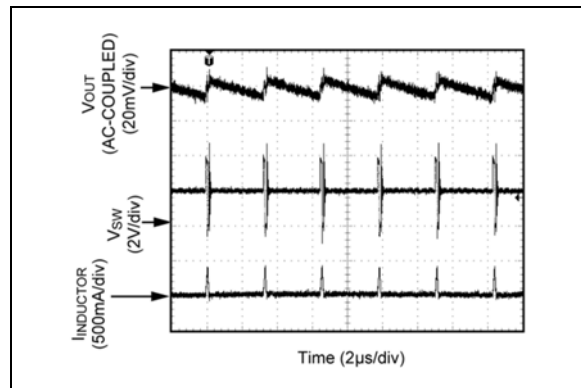

FIGURE 2-17: Switching Waveform - Discontinuous Mode $I_{OUT} = 10\text{ mA}$.

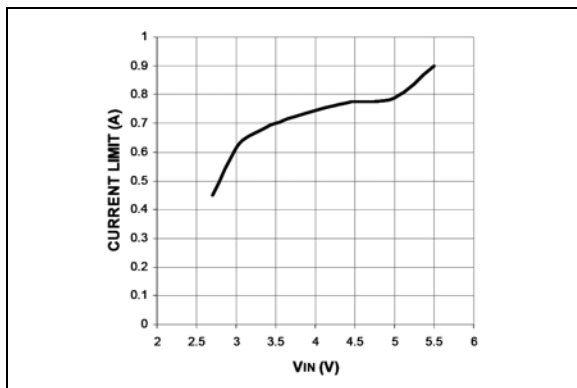

FIGURE 2-15: Current-Limit vs. Input Voltage.

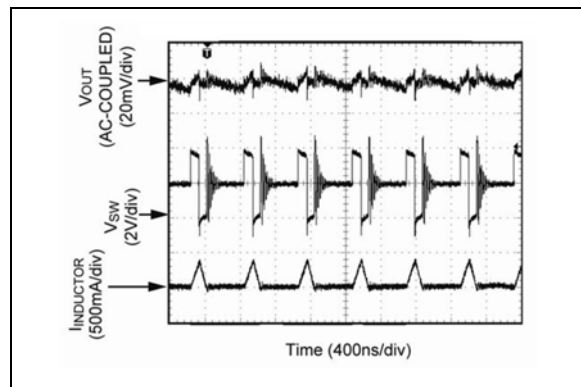

FIGURE 2-18: Switching Waveform - Discontinuous Mode $I_{OUT} = 50\text{ mA}$.

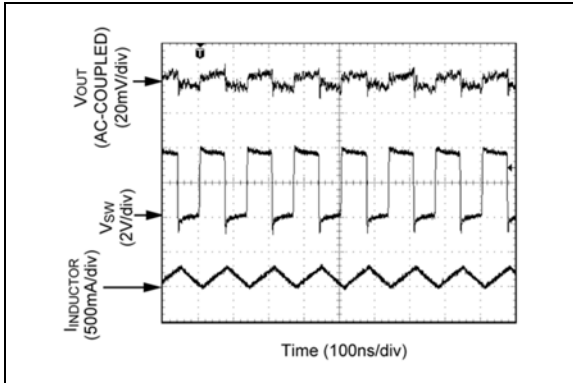

FIGURE 2-19: Switching Waveform - Continuous Mode $I_{OUT} = 120$ mA.

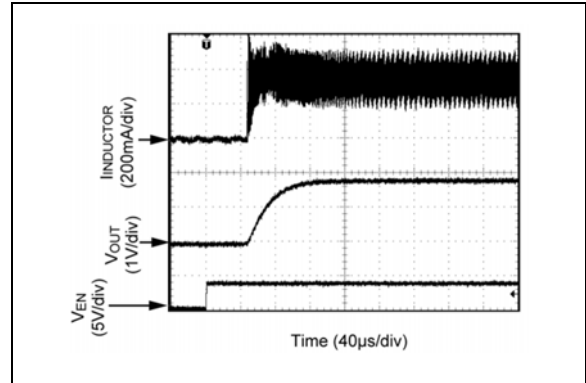

FIGURE 2-22: Start Up ($I_{OUT} = 350$ mA).

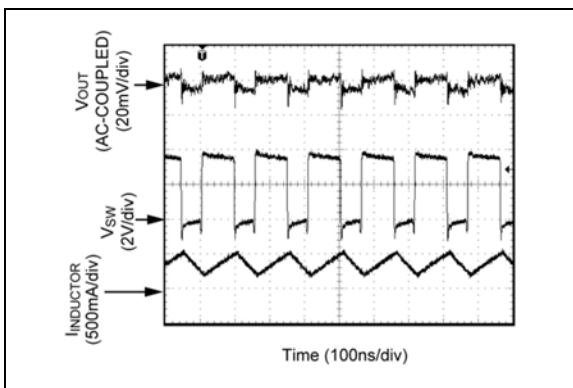

FIGURE 2-20: Switching Waveform - Continuous Mode $I_{OUT} = 300$ mA.

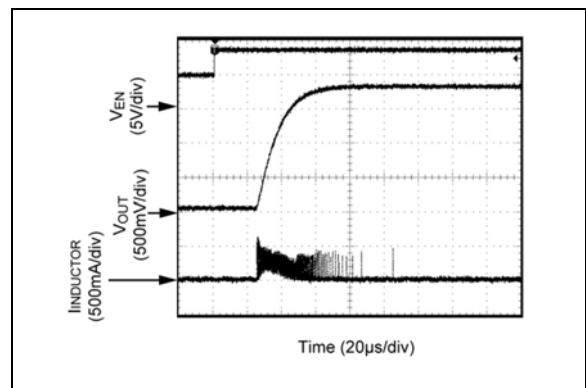

FIGURE 2-23: Start Up ($I_{OUT} = 1$ mA).

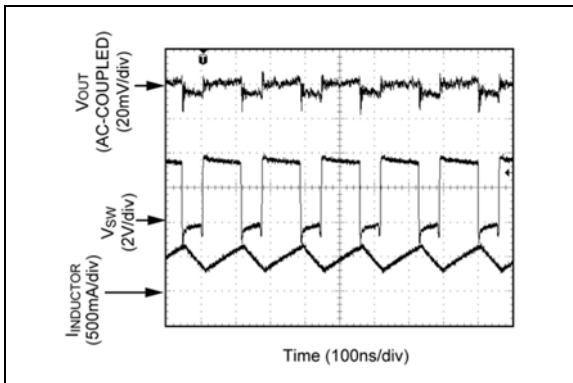

FIGURE 2-21: Switching Waveform - Continuous Mode $I_{OUT} = 400$ mA.

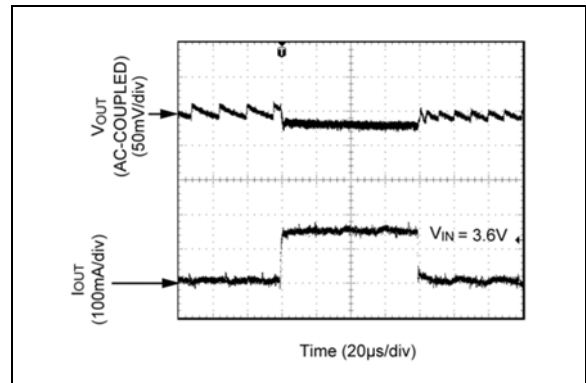

FIGURE 2-24: Load Transient 0 mA to 150 mA.

MIC33030

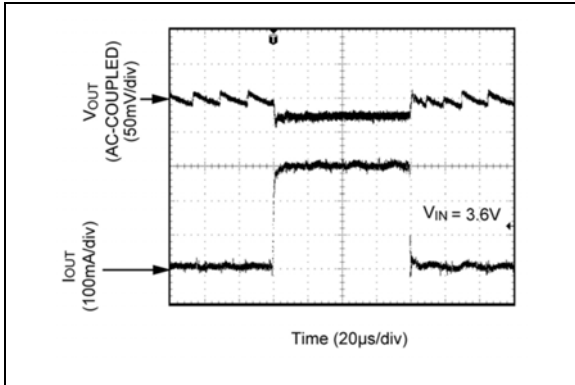

FIGURE 2-25: Load Transient 0 mA to 300 mA.

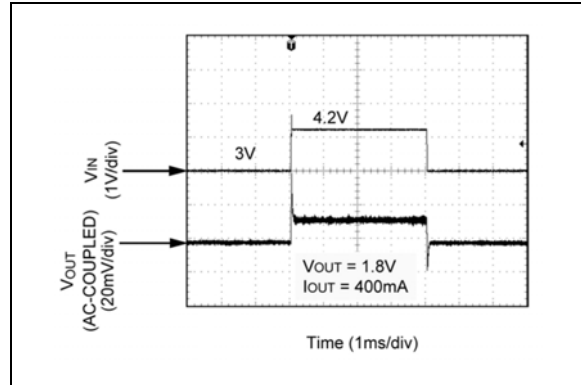

FIGURE 2-28: Line Transient (3V to 4.2V).

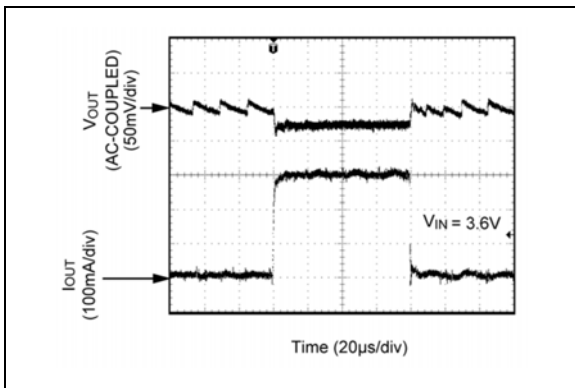

FIGURE 2-26: Load Transient (0 mA to 400 mA).

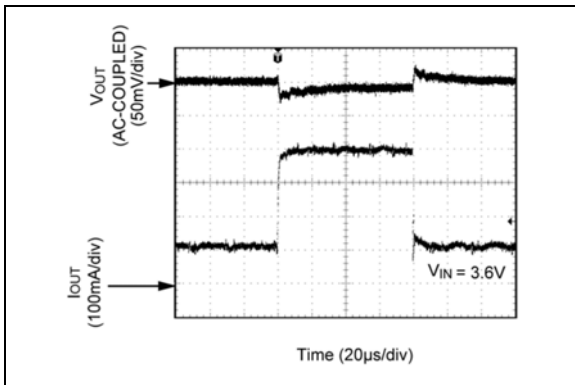

FIGURE 2-27: Load Transient (100 mA to 400 mA).

3.0 PIN DESCRIPTIONS

The descriptions of the pins are listed in [Table 3-1](#).

TABLE 3-1: PIN FUNCTION TABLE

Pin Number MIC33030 (Fixed Option)	Pin Number MIC33030 (ADJ Option)	Pin Name	Description
1	1	SNS	Sense: Connect to V_{OUT} as close to output capacitor as possible to sense output voltage.
2	—	NC	Not internally connected.
—	2	FB	Feedback: Connect resistor divider at this node to set output voltage. Resistors should be selected based on a nominal $V_{FB} = 0.62V$.
3	3	EN	Enable: Logic high enables operation of the regulator. Logic low will shut down the device. Do not leave floating.
4, 5	4, 5	SW	Switch: Internal power MOSFET output switches.
6, 7	6, 7	VOUT	Output Voltage: The output of the regulator. Connect to SNS pin. For adjustable option, connect to feedback resistor network.
8	8	PGND	Power Ground.
9	9	AGND	Analog Ground.
10	10	VIN	Input Voltage: Connect a capacitor to ground to decouple the noise.
ePAD	ePAD	HS PAD	Connect to PGND or AGND.

MIC33030

4.0 FUNCTIONAL DESCRIPTION

4.1 VIN

The input supply (V_{IN}) provides power to the internal MOSFETs for the switch mode regulator along with the internal control circuitry. The V_{IN} operating range is 2.7V to 5.5V, so an input capacitor with a minimum voltage rating of 6.3V is recommended. Due to the high switching speed, a minimum 2.2 μF bypass capacitor placed close to V_{IN} and the power ground (PGND) pin is required.

4.2 EN

A logic high signal on the enable pin activates the output voltage of the device. A logic low signal on the enable pin deactivates the output and reduces supply current to 0.01 μA . The MIC33030 features built in soft-start circuitry that reduces in-rush current and prevents the output voltage from overshooting at start up. Do not leave the enable pin floating.

4.3 SW

The switch (SW) connects directly to one end of the internal inductor and provides the current path during switching cycles. The other end of the inductor is connected to the load, SNS pin and output capacitor. Because the MIC33030 has an internal inductor, this pin is not routed in most applications.

4.4 VOUT

The output pin (V_{OUT}) is the output voltage pin following the internal inductor. Connect a minimum of 2.2 μF output filter capacitor to this pin.

4.5 SNS

The sense (SNS) pin is connected to the output of the device to provide feedback to the control circuitry. The SNS connection should be placed close to the output capacitor.

4.6 AGND

The analog ground (AGND) is the ground path for the biasing and control circuitry. The current loop for the signal ground should be separate from the power ground (PGND) loop.

4.7 FB (Adjustable Output Only)

The feedback pin (FB) allows the regulated output voltage to be set by applying an external resistor network. The internal reference voltage is 0.62V and the recommended value of R2 is 200 k Ω . The output voltage is calculated from the equation below:

EQUATION 4-1:

$$V_{OUT} = 0.62V \left(\frac{R1}{200k\Omega} + 1 \right)$$

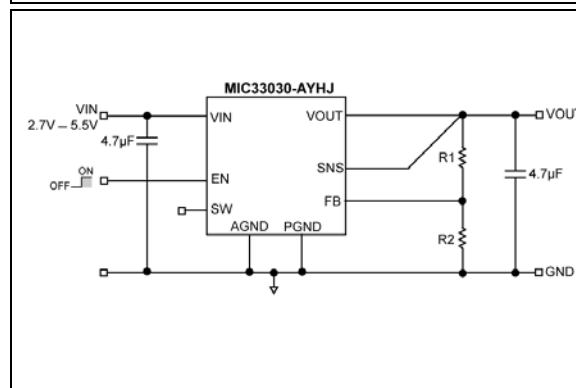

FIGURE 4-1: MIC33030-AYHJ Schematic.

4.8 PGND

The power ground pin is the ground path for the high current in PWM mode. The current loop for the power ground should be as small as possible and separate from the analog ground (AGND) loop as applicable.

5.0 APPLICATION INFORMATION

The MIC33030 is a high-performance DC/DC step down regulator that offers a small solution size. Supporting an output current up to 400 mA inside a tiny 2.5 mm x 2.0 mm HJDFN package and requiring only two external components, the MIC33030 meets today's miniature portable electronic device needs. Using the HyperLight Load[®] switching scheme, the MIC33030 is able to maintain high efficiency throughout the entire load range while providing ultra-fast load transient response. The following sections provide additional device application information.

5.1 Input Capacitor

A 2.2 μ F ceramic capacitor or greater should be placed close to the VIN pin and PGND pin for bypassing. A TDK C1608X5R0J475K, size 0603, 4.7 μ F ceramic capacitor is recommended based upon performance, size and cost. A X5R or X7R temperature rating is recommended for the input capacitor. Y5V temperature rating capacitors, aside from losing most of their capacitance over temperature, can also become resistive at high frequencies. This reduces their ability to filter out high frequency noise.

5.2 Output Capacitor

The MIC33030 is designed for use with a 2.2 μ F or greater ceramic output capacitor. Increasing the output capacitance will lower output ripple and improve load transient response but could increase solution size or cost. A low equivalent series resistance (ESR) ceramic output capacitor such as the TDK C1608X5R0J475K, size 0603, 4.7 μ F ceramic capacitor is recommended based upon performance, size and cost. Both the X7R or X5R temperature rating capacitors are recommended. The Y5V and Z5U temperature rating capacitors are not recommended due to their wide variation in capacitance over temperature and increased resistance at high frequencies.

5.3 Compensation

The MIC33030 is designed to be stable with a minimum of 2.2 μ F ceramic (X5R) output capacitor.

5.4 Duty Cycle

The typical maximum duty cycle of the MIC33030 is 90%.

5.5 Efficiency Considerations

Efficiency is defined as the amount of useful output power, divided by the amount of power supplied.

EQUATION 5-1:

$$\eta = \left(\frac{V_{OUT} \times I_{OUT}}{V_{IN} \times I_{IN}} \right) \times 100$$

Maintaining high efficiency serves two purposes. It reduces power dissipation in the power supply, reducing the need for heat sinks and thermal design considerations and it reduces consumption of current for battery powered applications. Reduced current draw from a battery increases the devices operating time which is critical in hand held devices.

There are two types of losses in switching converters; DC losses and switching losses. DC losses are simply the power dissipation of I^2R . Power is dissipated in the high-side switch during the on cycle. Power loss is equal to the high-side MOSFET $R_{DS(ON)}$ multiplied by the switch current squared. During the off cycle, the low-side N-channel MOSFET conducts, also dissipating power. Device operating current also reduces efficiency. The product of the quiescent (operating) current and the supply voltage represents another DC loss. The current required driving the gates on and off at a constant 8 MHz frequency and the switching transitions make up the switching losses.

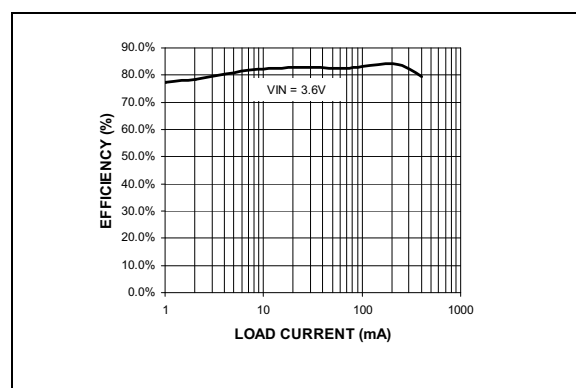

FIGURE 5-1: Efficiency under Load.

Figure 5-1 shows an efficiency curve. From no load to 100 mA, efficiency losses are dominated by quiescent current losses, gate drive and transition losses. By using the HyperLight Load[®] mode, the MIC33030 is able to maintain high efficiency at low output currents.

Over 100 mA, efficiency loss is dominated by MOSFET $R_{DS(ON)}$ and inductor losses. Higher input supply voltages will increase the gate to source threshold on the internal MOSFETs, thereby reducing the internal

MIC33030

$R_{DS(ON)}$. This improves efficiency by reducing DC losses in the device. All but the inductor losses are inherent to the device. In which case, inductor selection becomes increasingly critical in efficiency calculations. As the inductors are reduced in size, the DC resistance (DCR) can become quite significant.

The DCR losses can be calculated by using [Equation 5-2](#):

EQUATION 5-2:

$$P_{DCR} = I_{OUT}^2 \times DCR$$

From that, the loss in efficiency due to inductor resistance can be calculated by using [Equation 5-3](#):

EQUATION 5-3:

$$EfficiencyLoss = \left[1 - \left(\frac{V_{OUT} \times I_{OUT}}{V_{OUT} \times I_{OUT} + P_{DCR}} \right) \right] \times 100$$

Efficiency loss due to DCR is minimal at light loads and gains significance as the load is increased. Inductor selection becomes a trade-off between efficiency and size in this case.

The effect of MOSFET voltage drops and DCR losses in conjunction with the maximum duty cycle combine to limit maximum output voltage for a given input voltage. [Figure 5-2](#) shows this relationship based on the typical resistive losses in the MIC33030:

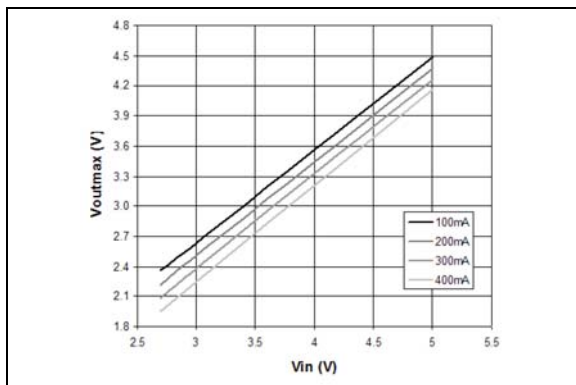

FIGURE 5-2: $V_{OUT(MAX)}$ vs. V_{IN}

5.6 HyperLight Load® Mode

MIC33030 uses a minimum on-time and off-time proprietary control loop. When the output voltage falls below the regulation threshold, the error comparator begins a switching cycle that turns the PMOS on and keeps it on for the duration of the minimum-on-time. This increases the output voltage. If the output voltage is over the regulation threshold, then the error comparator turns the PMOS off for a minimum off-time until the output drops below the threshold. The NMOS acts as an ideal rectifier that conducts when the PMOS is off. Using a NMOS switch instead of a diode allows for lower voltage drop across the switching device when it is on. The asynchronous switching combination between the PMOS and the NMOS allows the control loop to work in discontinuous mode for light load operations. In discontinuous mode, the MIC33030 works in pulse frequency modulation (PFM) to regulate the output. As the output current increases, the off-time decreases, thus provides more energy to the output. This switching scheme improves the efficiency of MIC33030 during light load currents by only switching when it is needed. As the load current increases, the MIC33030 goes into continuous conduction mode (CCM) and switches at a frequency centered at 8 MHz. The equation to calculate the load when the MIC33030 goes into continuous conduction mode may be approximated by the following [Equation 5-4](#):

EQUATION 5-4:

$$I_{LOAD} > \frac{(V_{IN} - V_{OUT}) \times D}{2L \times f}$$

The load at which MIC33030 transitions from HyperLight Load® mode to PWM mode is a function of the input voltage (V_{IN}), output voltage (V_{OUT}), duty cycle (D), inductance (L), and frequency (f). Because the inductance of MIC33030 is 0.36 μ H, the device will enter HyperLight Load® mode or PWM mode at approximately 150 mA.

5.7 Power Dissipation Considerations

As with all power devices, the ultimate current rating of the output is limited by the thermal properties of the package and the PCB it is mounted on. There is a simple, ohms law type relationship between thermal resistance, power dissipation, and temperature which are analogous to an electrical circuit:

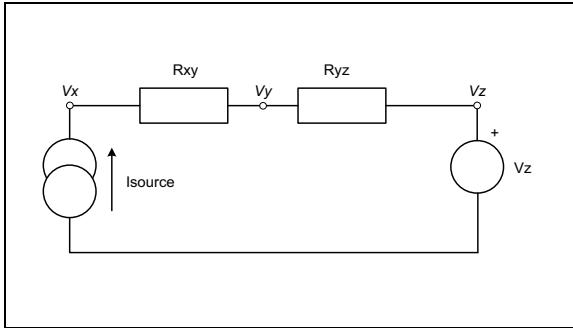

FIGURE 5-3:

From this simple circuit V_x can be calculated if I_{SOURCE} , V_z and the resistor values, R_{xy} and R_{yz} are known, using the [Equation 5-5](#):

EQUATION 5-5:

$$V_x = I_{SOURCE} \times (R_{XY} + R_{YZ}) + V_z$$

Thermal circuits can be considered using these same rules and can be drawn similarly replacing current sources with power dissipation (in Watts), resistance with thermal resistance (in °C/W) and voltage sources with temperature (in °C):

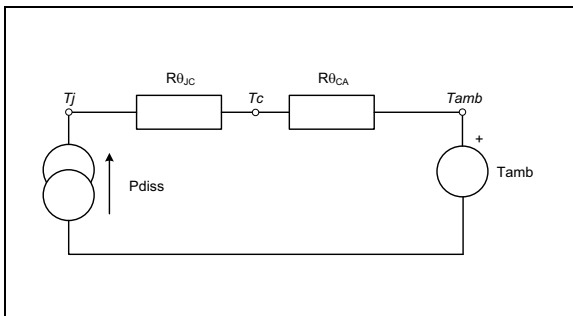

FIGURE 5-4:

Now replacing the variables in the equation for V_x , we can find the junction temperature (T_J) from power dissipation, ambient temperature and the known thermal resistance of the PCB ($R_{\theta_{CA}}$) and the package ($R_{\theta_{JC}}$):

EQUATION 5-6:

$$T_J = P_{DISS} \times (R_{\theta_{JC}} + R_{\theta_{CA}}) + T_{AMB}$$

As can be seen in [Figure 5-4](#), total thermal resistance $R_{\theta_{JA}} = R_{\theta_{JC}} + R_{\theta_{CA}}$. This can also be calculated using [Equation 5-6](#):

EQUATION 5-7:

$$T_J = P_{DISS} \times (R_{\theta_{JA}}) + T_{AMB}$$

Since effectively all of the power loss in the converter is dissipated within the MIC33030 package, P_{DISS} can be calculated by using [Equation 5-8](#):

EQUATION 5-8:

$$P_{DISS} = P_{OUT} \times \left(\frac{1}{\eta} - 1 \right)$$

Where:

$\eta =$ Efficiency taken from Efficiency Curves

$R_{\theta_{JC}}$ and $R_{\theta_{JA}}$ are found in the operating ratings section of the data sheet.

EXAMPLE:

A MIC33030 is intended to drive a 300 mA load at 1.8V and is placed on a printed circuit board which has a ground plane area of at least 25 mm square. The voltage source is a Li-ion battery with a lower operating threshold of 3V and the ambient temperature of the assembly can be up to 50°C.

Summary of variables:

- $I_{OUT} = 0.3A$
- $V_{OUT} = 1.8V$
- $V_{IN} = 3V$ to $4.2V$
- $T_{AMB} = 50^\circ C$
- $R_{\theta_{JA}} = 76^\circ C/W$

$\eta @ 300\text{ mA} = 75\%$ (worst case with $V_{IN} = 4.2V$) See [Section 2.0, Typical Performance Curves](#).

MIC33030

EQUATION 5-9:

$$P_{DISS} = 1.8 \times 0.3 \times \left(\frac{1}{0.75} - 1 \right) = 0.18 W$$

The worst case switch and inductor resistance will increase at higher temperatures, so a margin of 20% can be added to account for this:

EQUATION 5-10:

$$P_{DISS} = 0.18 \times 1.2 = 0.216 W$$

Therefore:

$$T_J = 0.216 W \times (76^\circ C/W) + 50^\circ C$$

$$T_J = 66^\circ C$$

This is well below the maximum 125°C.

6.0 PACKAGING INFORMATION

6.1 Package Marking Information

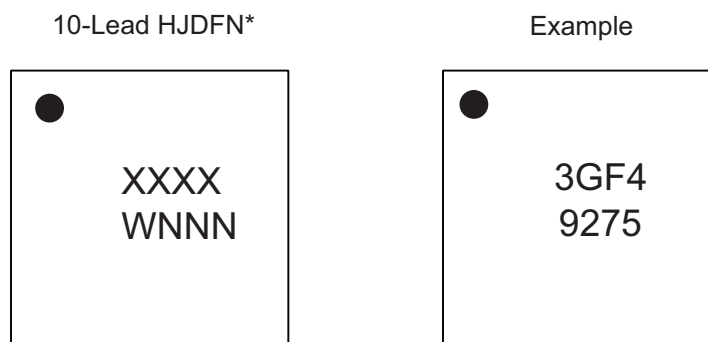

TABLE 6-1: MIC33030 PACKAGE MARKING CODES

Part Number	Output Voltage	Marking Code
MIC33030-AYHJ	ADJ	3GFA
MIC33030-JYHJ	2.5V	3GFJ
MIC33030-GYHJ	1.8V	3GFG
MIC33030-4YHJ	1.2V	3GF4

<p>Legend:</p> <p>XX...X Product code or customer-specific information</p> <p>Y Year code (last digit of calendar year)</p> <p>YY Year code (last 2 digits of calendar year)</p> <p>WW Week code (week of January 1 is week '01')</p> <p>NNN Alphanumeric traceability code</p> <p>(e3) Pb-free JEDEC® designator for Matte Tin (Sn)</p> <p>* This package is Pb-free. The Pb-free JEDEC designator ((e3)) can be found on the outer packaging for this package.</p> <p>●, ▲, ▼ Pin one index is identified by a dot, delta up, or delta down (triangle mark).</p>	<p>Note: In the event the full Microchip part number cannot be marked on one line, it will be carried over to the next line, thus limiting the number of available characters for customer-specific information. Package may or may not include the corporate logo.</p> <p>Underbar () and/or Overbar () symbol may not be to scale.</p>
---	---

MIC33030

10-Lead HJDFN 2.5 mm x 2.0 mm Package Outline and Recommended Land Pattern

TITLE

10 LEAD HJDFN 2.5 x 2.0 mm PACKAGE OUTLINE & RECOMMENDED LAND PATTERN

DRAWING #	HJDFN2520-10LD-PL-1	UNIT	MM
-----------	---------------------	------	----

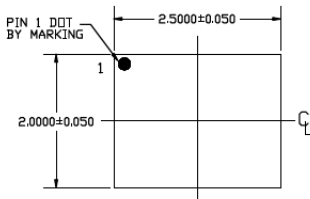

TOP VIEW

NOTE: 1, 2, 3

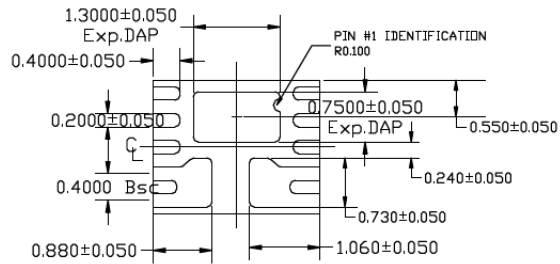

BOTTOM VIEW

NOTE: 1, 2

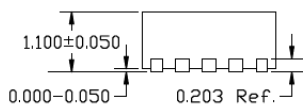

SIDE VIEW

NOTE: 1, 2

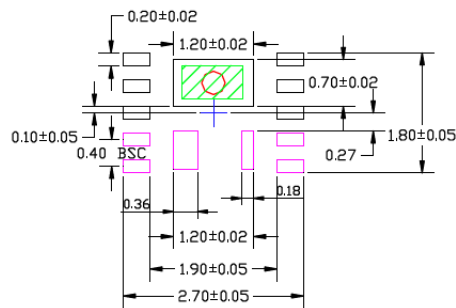

RECOMMENDED LAND PATTERN

NOTE: 4, 5, 6

NOTE:

1. MAX PACKAGE WARPAGE IS 0.05MM
2. MAX ALLOWABLE BURR IS 0.076MM IN ALL DIRECTIONS
3. PIN #1 IS ON TOP WILL BE LASER MARKED
4. GREEN RECTANGLE (SHADED AREA) REPRESENTS STENCIL OPENING ON EXPOSED AREA. SIZE IS 0.90X0.50 MM
5. RED CIRCLE REPRESENTS THERMAL VIAS & SHOULD BE CONNECTED TO GND FOR MAX PERFORMANCE. 0.30 - 0.35 MM RECOMMENDED DIAMETER
6. PURPLE PADS ARE OF A DIFFERENT POTENTIAL, DO NOT CONNECT TO GND

Note: For the most current package drawings, please see the Microchip Packaging Specification located at <http://www.microchip.com/packaging>.

APPENDIX A: REVISION HISTORY

Revision A (May 2018)

- Converted Micrel document MIC33030 to Microchip data sheet DS20006026A.
- Minor text changes throughout.

MIC33030

NOTES:

PRODUCT IDENTIFICATION SYSTEM

To order or obtain information, e.g., on pricing or delivery, contact your local Microchip representative or sales office.

<u>PART NO.</u>	<u>-X</u>	<u>X</u>	<u>X</u>	<u>-XX</u>
Device	Output Voltage	Junction Temperature Range	Package Option	Media Type
<p>Device: MIC33030: 8 MHz 400 mA Internal Inductor Buck Regulator with HyperLight Load®</p>				
<p>Output Voltage: 4 = 1.2V G* = 1.8V J = 2.5V A = Adjustable</p>				
<p>Junction Temperature Range: Y = -40°C to +125°C</p>				
<p>Package: HJ = 10-Lead 2.5 mm x 2.0 mm x 1.15 mm HJDFN</p>				
<p>Media Type: T5 = 500/Reel TR = 5000/Reel</p>				
<p>Note: Other voltages available. Contact Factory for details.</p>				
<p>Examples:</p> <p>a) MIC33030-4YHJ-T5: 8 MHz 400 mA Internal Inductor Buck Regulator with HyperLight Load®, 1.2V Fixed Output Voltage, -40°C to +125°C Junction Temperature Range, Pb-Free, RoHS Compliant, 10-Lead HJDFN Package, 500/Reel</p> <p>b) MIC33030-GYHJ-TR: 8 MHz 400 mA Internal Inductor Buck Regulator with HyperLight Load®, 1.8V Fixed Output Voltage, -40°C to +125°C Junction Temperature Range, Pb-Free, RoHS Compliant, 10-Lead HJDFN Package, 5000/Reel</p> <p>c) MIC33030-JYHJ-T5: 8 MHz 400 mA Internal Inductor Buck Regulator with HyperLight Load®, 2.5V Fixed Output Voltage, -40°C to +125°C Junction Temperature Range, Pb-Free, RoHS Compliant, 10-Lead HJDFN Package, 500/Reel</p> <p>d) MIC33030-AYHJ-TR: 8 MHz 400 mA Internal Inductor Buck Regulator with HyperLight Load®, Adjustable Output Voltage, -40°C to +125°C Junction Temperature Range, Pb-Free, RoHS Compliant, 10-Lead HJDFN Package, 5000/Reel</p> <p>e) MIC33030-4YHJ-TR: 8 MHz 400 mA Internal Inductor Buck Regulator with HyperLight Load®, 1.2V Fixed Output Voltage, -40°C to +125°C Junction Temperature Range, 10-Lead HJDFN Package, 5000/Reel</p> <p>Note 1: Tape and Reel identifier only appears in the catalog part number description. This identifier is used for ordering purposes and is not printed on the device package. Check with your Microchip Sales Office for package availability with the Tape and Reel option.</p>				

Note the following details of the code protection feature on Microchip devices:

- Microchip products meet the specification contained in their particular Microchip Data Sheet.
- Microchip believes that its family of products is one of the most secure families of its kind on the market today, when used in the intended manner and under normal conditions.
- There are dishonest and possibly illegal methods used to breach the code protection feature. All of these methods, to our knowledge, require using the Microchip products in a manner outside the operating specifications contained in Microchip's Data Sheets. Most likely, the person doing so is engaged in theft of intellectual property.
- Microchip is willing to work with the customer who is concerned about the integrity of their code.
- Neither Microchip nor any other semiconductor manufacturer can guarantee the security of their code. Code protection does not mean that we are guaranteeing the product as “unbreakable.”

Code protection is constantly evolving. We at Microchip are committed to continuously improving the code protection features of our products. Attempts to break Microchip's code protection feature may be a violation of the Digital Millennium Copyright Act. If such acts allow unauthorized access to your software or other copyrighted work, you may have a right to sue for relief under that Act.

Information contained in this publication regarding device applications and the like is provided only for your convenience and may be superseded by updates. It is your responsibility to ensure that your application meets with your specifications. MICROCHIP MAKES NO REPRESENTATIONS OR WARRANTIES OF ANY KIND WHETHER EXPRESS OR IMPLIED, WRITTEN OR ORAL, STATUTORY OR OTHERWISE, RELATED TO THE INFORMATION, INCLUDING BUT NOT LIMITED TO ITS CONDITION, QUALITY, PERFORMANCE, MERCHANTABILITY OR FITNESS FOR PURPOSE. Microchip disclaims all liability arising from this information and its use. Use of Microchip devices in life support and/or safety applications is entirely at the buyer's risk, and the buyer agrees to defend, indemnify and hold harmless Microchip from any and all damages, claims, suits, or expenses resulting from such use. No licenses are conveyed, implicitly or otherwise, under any Microchip intellectual property rights unless otherwise stated.

Microchip received ISO/TS-16949:2009 certification for its worldwide headquarters, design and wafer fabrication facilities in Chandler and Tempe, Arizona; Gresham, Oregon and design centers in California and India. The Company's quality system processes and procedures are for its PIC[®] MCUs and dsPIC[®] DSCs, KEELoC[®] code hopping devices, Serial EEPROMs, microperipherals, nonvolatile memory and analog products. In addition, Microchip's quality system for the design and manufacture of development systems is ISO 9001:2000 certified.

**QUALITY MANAGEMENT SYSTEM
CERTIFIED BY DNV
= ISO/TS 16949 =**

Trademarks

The Microchip name and logo, the Microchip logo, AnyRate, AVR, AVR logo, AVR Freaks, BeaconThings, BitCloud, CryptoMemory, CryptoRF, dsPIC, FlashFlex, flexPWR, Heldo, JukeBlox, KEELoC, KEELoC logo, Klear, LANCheck, LINK MD, maXStylus, maXTouch, MediaLB, megaAVR, MOST, MOST logo, MPLAB, OptoLyzer, PIC, picoPower, PICSTART, PIC32 logo, Prochip Designer, QTouch, RightTouch, SAM-BA, SpyNIC, SST, SST Logo, SuperFlash, tinyAVR, UNI/O, and XMEGA are registered trademarks of Microchip Technology Incorporated in the U.S.A. and other countries.

ClockWorks, The Embedded Control Solutions Company, EtherSynch, Hyper Speed Control, HyperLight Load, IntelliMOS, mTouch, Precision Edge, and Quiet-Wire are registered trademarks of Microchip Technology Incorporated in the U.S.A.

Adjacent Key Suppression, AKS, Analog-for-the-Digital Age, Any Capacitor, AnyIn, AnyOut, BodyCom, chipKIT, chipKIT logo, CodeGuard, CryptoAuthentication, CryptoCompanion, CryptoController, dsPICDEM, dsPICDEM.net, Dynamic Average Matching, DAM, ECAN, EtherGREEN, In-Circuit Serial Programming, ICSP, Inter-Chip Connectivity, JitterBlocker, KlearNet, KlearNet logo, Mindi, MiWi, motorBench, MPASM, MPF, MPLAB Certified logo, MPLIB, MPLINK, MultiTRAK, NetDetach, Omniscient Code Generation, PICDEM, PICDEM.net, PICKit, PICTail, PureSilicon, QMatrix, RightTouch logo, REAL ICE, Ripple Blocker, SAM-ICE, Serial Quad I/O, SMART-I.S., SQI, SuperSwitcher, SuperSwitcher II, Total Endurance, TSHARC, USBCheck, VariSense, ViewSpan, WiperLock, Wireless DNA, and ZENA are trademarks of Microchip Technology Incorporated in the U.S.A. and other countries.

SQTP is a service mark of Microchip Technology Incorporated in the U.S.A.

Silicon Storage Technology is a registered trademark of Microchip Technology Inc. in other countries.

GestIC is a registered trademark of Microchip Technology Germany II GmbH & Co. KG, a subsidiary of Microchip Technology Inc., in other countries.

All other trademarks mentioned herein are property of their respective companies.

© 2018, Microchip Technology Incorporated, All Rights Reserved.
ISBN: 978-1-5224-2977-7



MICROCHIP

Worldwide Sales and Service

AMERICAS

Corporate Office
2355 West Chandler Blvd.
Chandler, AZ 85224-6199
Tel: 480-792-7200
Fax: 480-792-7277
Technical Support:
<http://www.microchip.com/support>
Web Address:
www.microchip.com

Atlanta

Duluth, GA
Tel: 678-957-9614
Fax: 678-957-1455

Austin, TX

Tel: 512-257-3370

Boston

Westborough, MA
Tel: 774-760-0087
Fax: 774-760-0088

Chicago

Itasca, IL
Tel: 630-285-0071
Fax: 630-285-0075

Dallas

Addison, TX
Tel: 972-818-7423
Fax: 972-818-2924

Detroit

Novi, MI
Tel: 248-848-4000

Houston, TX

Tel: 281-894-5983

Indianapolis

Noblesville, IN
Tel: 317-773-8323
Fax: 317-773-5453
Tel: 317-536-2380

Los Angeles

Mission Viejo, CA
Tel: 949-462-9523
Fax: 949-462-9608
Tel: 951-273-7800

Raleigh, NC

Tel: 919-844-7510

New York, NY

Tel: 631-435-6000

San Jose, CA

Tel: 408-735-9110
Tel: 408-436-4270

Canada - Toronto

Tel: 905-695-1980
Fax: 905-695-2078

ASIA/PACIFIC

Australia - Sydney
Tel: 61-2-9868-6733

China - Beijing
Tel: 86-10-8569-7000

China - Chengdu
Tel: 86-28-8665-5511

China - Chongqing
Tel: 86-23-8980-9588

China - Dongguan
Tel: 86-769-8702-9880

China - Guangzhou
Tel: 86-20-8755-8029

China - Hangzhou
Tel: 86-571-8792-8115

China - Hong Kong SAR
Tel: 852-2943-5100

China - Nanjing
Tel: 86-25-8473-2460

China - Qingdao
Tel: 86-532-8502-7355

China - Shanghai
Tel: 86-21-3326-8000

China - Shenyang
Tel: 86-24-2334-2829

China - Shenzhen
Tel: 86-755-8864-2200

China - Suzhou
Tel: 86-186-6233-1526

China - Wuhan
Tel: 86-27-5980-5300

China - Xian
Tel: 86-29-8833-7252

China - Xiamen
Tel: 86-592-2388138

China - Zhuhai
Tel: 86-756-3210040

ASIA/PACIFIC

India - Bangalore
Tel: 91-80-3090-4444

India - New Delhi
Tel: 91-11-4160-8631

India - Pune
Tel: 91-20-4121-0141

Japan - Osaka
Tel: 81-6-6152-7160

Japan - Tokyo
Tel: 81-3-6880-3770

Korea - Daegu
Tel: 82-53-744-4301

Korea - Seoul
Tel: 82-2-554-7200

Malaysia - Kuala Lumpur
Tel: 60-3-7651-7906

Malaysia - Penang
Tel: 60-4-227-8870

Philippines - Manila
Tel: 63-2-634-9065

Singapore
Tel: 65-6334-8870

Taiwan - Hsin Chu
Tel: 886-3-577-8366

Taiwan - Kaohsiung
Tel: 886-7-213-7830

Taiwan - Taipei
Tel: 886-2-2508-8600

Thailand - Bangkok
Tel: 66-2-694-1351

Vietnam - Ho Chi Minh
Tel: 84-28-5448-2100

EUROPE

Austria - Wels
Tel: 43-7242-2244-39
Fax: 43-7242-2244-393

Denmark - Copenhagen
Tel: 45-4450-2828
Fax: 45-4485-2829

Finland - Espoo
Tel: 358-9-4520-820

France - Paris
Tel: 33-1-69-53-63-20
Fax: 33-1-69-30-90-79

Germany - Garching
Tel: 49-8931-9700

Germany - Haan
Tel: 49-2129-3766400

Germany - Heilbronn
Tel: 49-7131-67-3636

Germany - Karlsruhe
Tel: 49-721-625370

Germany - Munich
Tel: 49-89-627-144-0
Fax: 49-89-627-144-44

Germany - Rosenheim
Tel: 49-8031-354-560

Israel - Ra'anana
Tel: 972-9-744-7705

Italy - Milan
Tel: 39-0331-742611
Fax: 39-0331-466781

Italy - Padova
Tel: 39-049-7625286

Netherlands - Drunen
Tel: 31-416-690399
Fax: 31-416-690340

Norway - Trondheim
Tel: 47-7289-7561

Poland - Warsaw
Tel: 48-22-3325737

Romania - Bucharest
Tel: 40-21-407-87-50

Spain - Madrid
Tel: 34-91-708-08-90
Fax: 34-91-708-08-91

Sweden - Gothenberg
Tel: 46-31-704-60-40

Sweden - Stockholm
Tel: 46-8-5090-4654

UK - Wokingham
Tel: 44-118-921-5800
Fax: 44-118-921-5820

Looking for pricing, stock, or lifecycle information?

Click below to explore more details on WIN SOURCE:

- ⊖ [View MIC33030-GYHJ-TR on WIN SOURCE](#)
- ⊖ [Microchip Technology](#) Information

Optimize Your Supply Chain with WIN SOURCE Solutions

- ✓ Global Sourcing Solution
- ✓ Obsolete Management
- ✓ Cost Control Management
- ✓ Shortage Management
- ✓ Alternative Solution
- ✓ Excess Inventory Management