



**THE DATASHEET OF
MRF10150**



Microwave Pulse Power Silicon NPN Transistor 150W (peak), 1025–1150MHz

Rev. V1

Designed for 1025–1150 MHz pulse common base amplifier applications such as TCAS, TACAN and Mode-S transmitters.

- Guaranteed performance @ 1090 MHz
Output power = 150 W Peak
Gain = 9.5 dB min, 10.0 dB (typ.)
- 100% tested for load mismatch at all phase angles with 10:1 VSWR
- Hermetically sealed package
- Silicon nitride passivated
- Gold metallized, emitter ballasted for long life and resistance to metal migration
- Internal input and output matching
- Characterized with 10 μ s, 10% duty cycle pulses
- Recommended driver for a pair of MRF10500 transistors

Product Image

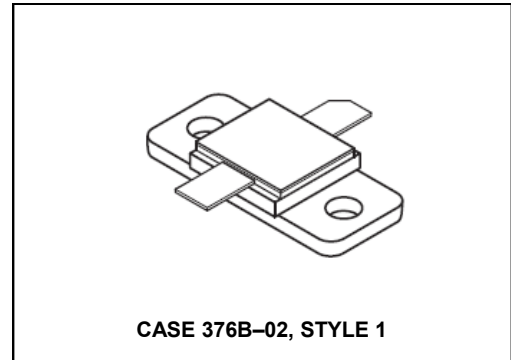

MAXIMUM RATINGS

Rating	Symbol	Value	Unit
Collector–Emitter Voltage	V_{CES}	65	Vdc
Collector–Base Voltage	V_{CBO}	65	Vdc
Emitter–Base Voltage	V_{EBO}	3.5	Vdc
Collector Current — Peak (1)	I_C	14	Adc
Total Device Dissipation @ $T_C = 25^\circ\text{C}$ (1), (2) Derate above 25°C	P_D	700 4.0	Watts $W/^\circ\text{C}$
Storage Temperature Range	T_{stg}	–65 to +200	$^\circ\text{C}$
Junction Temperature	T_J	200	$^\circ\text{C}$

THERMAL CHARACTERISTICS

Characteristic	Symbol	Max	Unit
Thermal Resistance, Junction to Case (3)	$R_{\theta JC}$	0.25	$^\circ\text{C/W}$

NOTES:

1. Under pulse RF operating conditions.
2. These devices are designed for RF operation. The total device dissipation rating applies only when the devices are operated as pulsed RF amplifiers.
3. Thermal Resistance is determined under specified RF operating conditions by infrared measurement techniques. (Worst case θ_{JC} value measured @ 10 μ s, 10%.)

Microwave Pulse Power Silicon NPN Transistor 150W (peak), 1025–1150MHz

Rev. V1

ELECTRICAL CHARACTERISTICS (T_C = 25°C unless otherwise noted.)

Characteristic	Symbol	Min	Typ	Max	Unit
----------------	--------	-----	-----	-----	------

OFF CHARACTERISTICS

Collector–Emitter Breakdown Voltage (I _C = 60 mAdc, V _{BE} = 0)	V _{(BR)CES}	65	—	—	Vdc
Collector–Base Breakdown Voltage (I _C = 60 mAdc, I _E = 0)	V _{(BR)CBO}	65	—	—	Vdc
Emitter–Base Breakdown Voltage (I _E = 10 mAdc, I _C = 0)	V _{(BR)EBO}	3.5	—	—	Vdc
Collector Cutoff Current (V _{CB} = 36 Vdc, I _E = 0)	I _{CBO}	—	—	25	mAdc

ON CHARACTERISTICS

DC Current Gain (I _C = 5.0 Adc, V _{CE} = 5.0 Vdc)	h _{FE}	20	—	—	—
---	-----------------	----	---	---	---

FUNCTIONAL TESTS

Common–Base Amplifier Power Gain (V _{CC} = 50 Vdc, P _{out} = 150 W Peak, f = 1090 MHz)	G _{PB}	9.5	10	—	dB
Collector Efficiency (V _{CC} = 50 Vdc, P _{out} = 150 W Peak, f = 1090 MHz)	η	40	—	—	%
Load Mismatch (V _{CC} = 50 Vdc, P _{out} = 150 W Peak, f = 1090 MHz, VSWR = 10:1 All Phase Angles)	ψ	No Degradation in Output Power			

Microwave Pulse Power Silicon NPN Transistor 150W (peak), 1025–1150MHz

Rev. V1

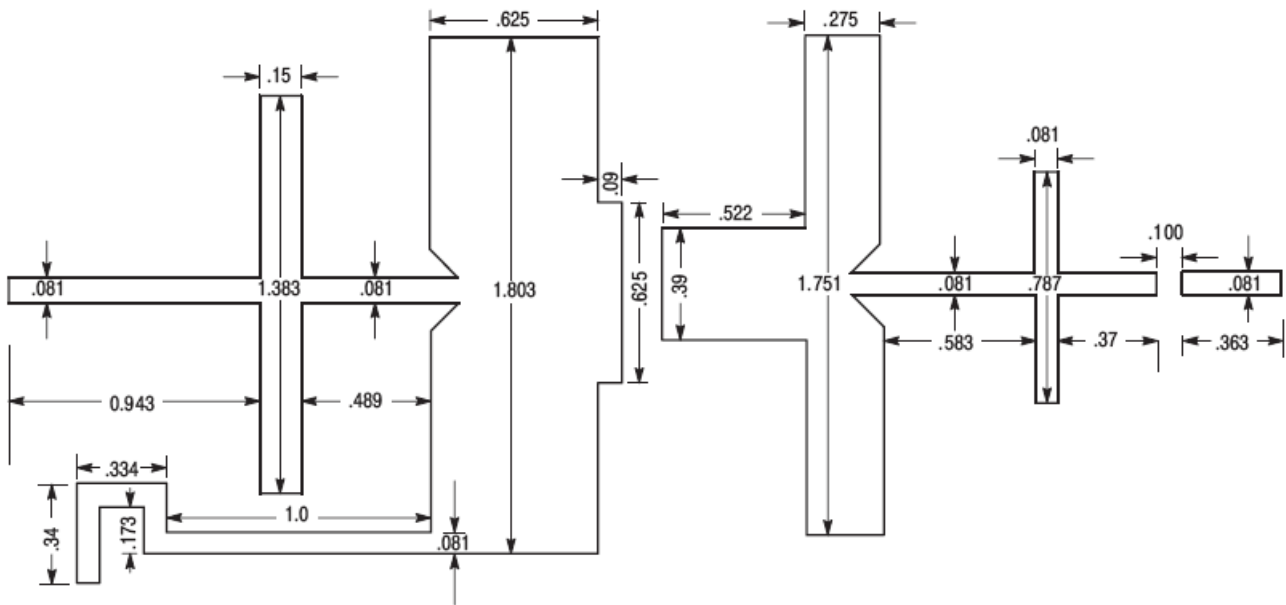
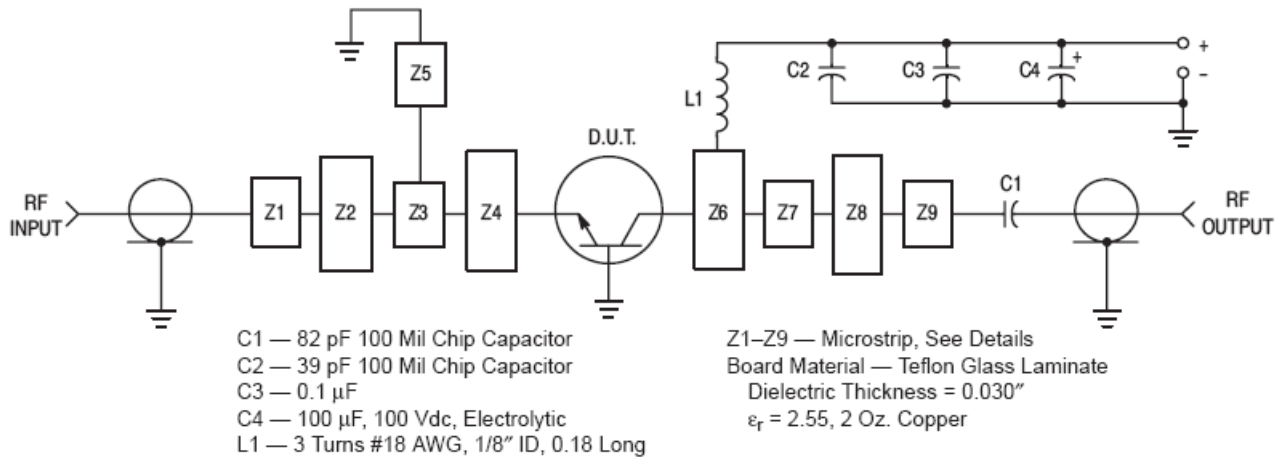

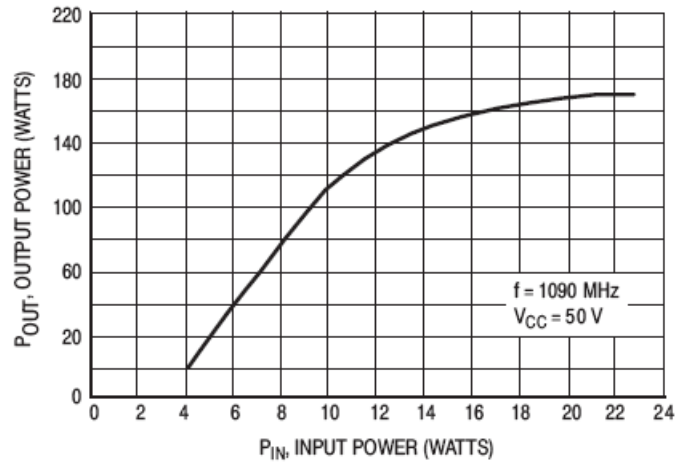
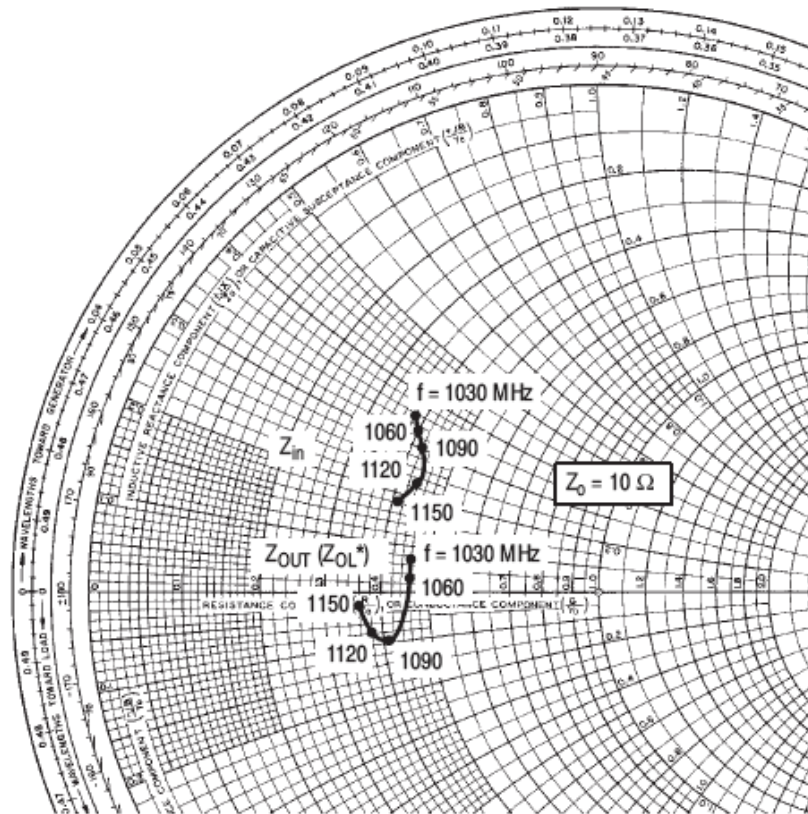

Figure 2. Output Power versus Input Power



$P_{OUT} = 150 \text{ W Pk}$ $V_{CC} = 50 \text{ V}$

f MHz	Z_{in} OHMS	$Z_{OL}^* (Z_{OUT})$ OHMS
1030	$3.8 + j3.5$	$4.6 + j0.7$
1060	$4.0 + j3.3$	$4.6 + j0.3$
1090	$4.2 + j3.0$	$4.1 - j1.0$
1120	$4.4 + j2.3$	$3.8 - j0.8$
1150	$4.1 + j1.8$	$3.6 - j0.3$

Z_{OL}^* is the conjugate of the optimum load impedance into which the device operates at a given output power voltage and frequency.

Figure 3. Series Equivalent Input/Output Impedances

PACKAGE DIMENSIONS

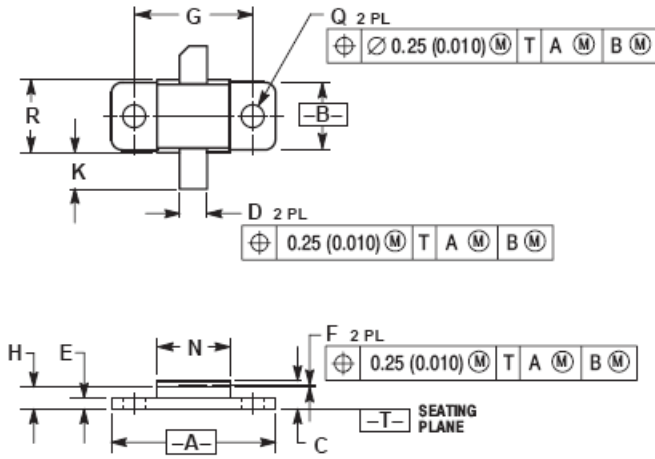

- NOTES:
1. DIMENSIONING AND TOLERANCING PER ANSI Y14.5M, 1982.
 2. CONTROLLING DIMENSION: INCH.

DIM	INCHES		MILLIMETERS	
	MIN	MAX	MIN	MAX
A	0.890	0.910	22.61	23.11
B	0.370	0.400	9.40	10.16
C	0.145	0.160	3.69	4.06
D	0.140	0.160	3.56	4.06
E	0.055	0.065	1.40	1.65
F	0.003	0.006	0.08	0.15
G	0.650 BSC		16.51 BSC	
H	0.110	0.130	2.80	3.30
K	0.180	0.220	4.57	5.59
N	0.390	0.410	9.91	10.41
Q	0.115	0.135	2.93	3.42
R	0.390	0.140	9.91	10.41

- STYLE 1:
 PIN 1. COLLECTOR
 2. EMITTER
 3. BASE

CASE 376B-02
ISSUE B

M/A-COM Technology Solutions Inc. All rights reserved.

Information in this document is provided in connection with M/A-COM Technology Solutions Inc ("MACOM") products. These materials are provided by MACOM as a service to its customers and may be used for informational purposes only. Except as provided in MACOM's Terms and Conditions of Sale for such products or in any separate agreement related to this document, MACOM assumes no liability whatsoever. MACOM assumes no responsibility for errors or omissions in these materials. MACOM may make changes to specifications and product descriptions at any time, without notice. MACOM makes no commitment to update the information and shall have no responsibility whatsoever for conflicts or incompatibilities arising from future changes to its specifications and product descriptions. No license, express or implied, by estoppel or otherwise, to any intellectual property rights is granted by this document.

THESE MATERIALS ARE PROVIDED "AS IS" WITHOUT WARRANTY OF ANY KIND, EITHER EXPRESS OR IMPLIED, RELATING TO SALE AND/OR USE OF MACOM PRODUCTS INCLUDING LIABILITY OR WARRANTIES RELATING TO FITNESS FOR A PARTICULAR PURPOSE, CONSEQUENTIAL OR INCIDENTAL DAMAGES, MERCHANTABILITY, OR INFRINGEMENT OF ANY PATENT, COPYRIGHT OR OTHER INTELLECTUAL PROPERTY RIGHT. MACOM FURTHER DOES NOT WARRANT THE ACCURACY OR COMPLETENESS OF THE INFORMATION, TEXT, GRAPHICS OR OTHER ITEMS CONTAINED WITHIN THESE MATERIALS. MACOM SHALL NOT BE LIABLE FOR ANY SPECIAL, INDIRECT, INCIDENTAL, OR CONSEQUENTIAL DAMAGES, INCLUDING WITHOUT LIMITATION, LOST REVENUES OR LOST PROFITS, WHICH MAY RESULT FROM THE USE OF THESE MATERIALS.

MACOM products are not intended for use in medical, lifesaving or life sustaining applications. MACOM customers using or selling MACOM products for use in such applications do so at their own risk and agree to fully indemnify MACOM for any damages resulting from such improper use or sale.

Looking for pricing, stock, or lifecycle information?

Click below to explore more details on WIN SOURCE:

- ⊖ [View MRF10150 on WIN SOURCE](#)
- ⊖ [M/A-Com Technology Solutions Information](#)

Optimize Your Supply Chain with WIN SOURCE Solutions

- ✓ Global Sourcing Solution
- ✓ Obsolete Management
- ✓ Cost Control Management
- ✓ Shortage Management
- ✓ Alternative Solution
- ✓ Excess Inventory Management