



# THE DATASHEET OF MRF317



## The RF Line NPN Silicon Power Transistor 100W, 30-200MHz, 28V

Rev. V1

Designed primarily for wideband large-signal output amplifier stages in 30–200 MHz frequency range.

- Guaranteed performance at 150 MHz, 28 Vdc  
Output power = 100 W  
Minimum gain = 9.0 dB
- Built-in matching network for broadband operation
- 100% tested for load mismatch at all phase angles with 30:1 VSWR
- Gold metallization system for high reliability
- High output saturation power — ideally suited for 30 W carrier/120 W
- Peak AM amplifier service
- Guaranteed performance in broadband test fixture

### Product Image

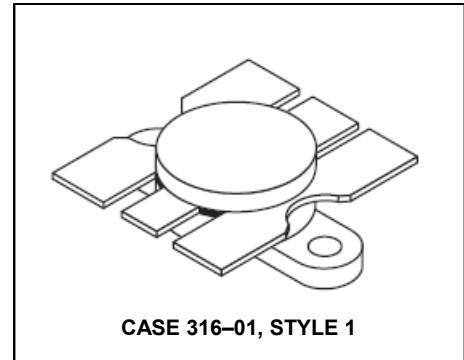

### MAXIMUM RATINGS

Rating	Symbol	Value	Unit
Collector–Emitter Voltage	$V_{CEO}$	35	Vdc
Collector–Base Voltage	$V_{CBO}$	65	Vdc
Emitter–Base Voltage	$V_{EBO}$	4.0	Vdc
Collector Current — Continuous — Peak (10 seconds)	$I_C$	12 18	Adc
Total Device Dissipation @ $T_C = 25^\circ\text{C}$ (1) Derate above $25^\circ\text{C}$	$P_D$	270 1.54	Watts W/ $^\circ\text{C}$
Storage Temperature Range	$T_{stg}$	–65 to +150	$^\circ\text{C}$

### THERMAL CHARACTERISTICS

Characteristic	Symbol	Max	Unit
Thermal Resistance, Junction to Case	$R_{\theta JC}$	0.65	$^\circ\text{C/W}$

### ELECTRICAL CHARACTERISTICS ( $T_C = 25^\circ\text{C}$ unless otherwise noted.)

Characteristic	Symbol	Min	Typ	Max	Unit
----------------	--------	-----	-----	-----	------

## The RF Line NPN Silicon Power Transistor 100W, 30-200MHz, 28V

Rev. V1

### OFF CHARACTERISTICS

Collector–Emitter Breakdown Voltage ( $I_C = 100 \text{ mAdc}$ , $I_B = 0$ )	$V_{(BR)CEO}$	35	—	—	Vdc
Collector–Emitter Breakdown Voltage ( $I_C = 100 \text{ mAdc}$ , $V_{BE} = 0$ )	$V_{(BR)CES}$	65	—	—	Vdc
Collector–Base Breakdown Voltage ( $I_C = 100 \text{ mAdc}$ , $I_E = 0$ )	$V_{(BR)CBO}$	65	—	—	Vdc
Emitter–Base Breakdown Voltage ( $I_E = 10 \text{ mAdc}$ , $I_C = 0$ )	$V_{(BR)EBO}$	4.0	—	—	Vdc
Collector Cutoff Current ( $V_{CB} = 30 \text{ Vdc}$ , $I_E = 0$ )	$I_{CBO}$	—	—	5.0	mAdc

### ON CHARACTERISTICS

DC Current Gain ( $I_C = 5.0 \text{ Adc}$ , $V_{CE} = 5.0 \text{ Vdc}$ )	$h_{FE}$	10	25	80	—
---	----------	----	----	----	---

NOTE:

(continued)

1. This device is designed for RF operation. The total device dissipation rating applies only when the device is operated as an RF amplifier.

### ELECTRICAL CHARACTERISTICS — continued ( $T_C = 25^\circ\text{C}$ unless otherwise noted.)

Characteristic	Symbol	Min	Typ	Max	Unit
----------------	--------	-----	-----	-----	------

### DYNAMIC CHARACTERISTICS

Output Capacitance ( $V_{CB} = 28 \text{ Vdc}$ , $I_E = 0$ , $f = 1.0 \text{ MHz}$ )	$C_{ob}$	—	150	175	pF
---	----------	---	-----	-----	----

### FUNCTIONAL TESTS (Figure 2)

Common–Emitter Amplifier Power Gain ( $V_{CC} = 28 \text{ Vdc}$ , $P_{out} = 100 \text{ W}$ , $f = 150 \text{ MHz}$ , $I_C (\text{Max}) = 6.5 \text{ Adc}$ )	$G_{PE}$	9.0	10	—	dB
Collector Efficiency ( $V_{CC} = 28 \text{ Vdc}$ , $P_{out} = 100 \text{ W}$ , $f = 150 \text{ MHz}$ , $I_C (\text{Max}) = 6.5 \text{ Adc}$ )	$\eta$	55	60	—	%
Load Mismatch ( $V_{CC} = 28 \text{ Vdc}$ , $P_{out} = 100 \text{ W CW}$ , $f = 150 \text{ MHz}$ , $VSWR = 30:1$ all phase angles)	$\psi$	No Degradation in Output Power			

## The RF Line NPN Silicon Power Transistor 100W, 30-200MHz, 28V

Rev. V1

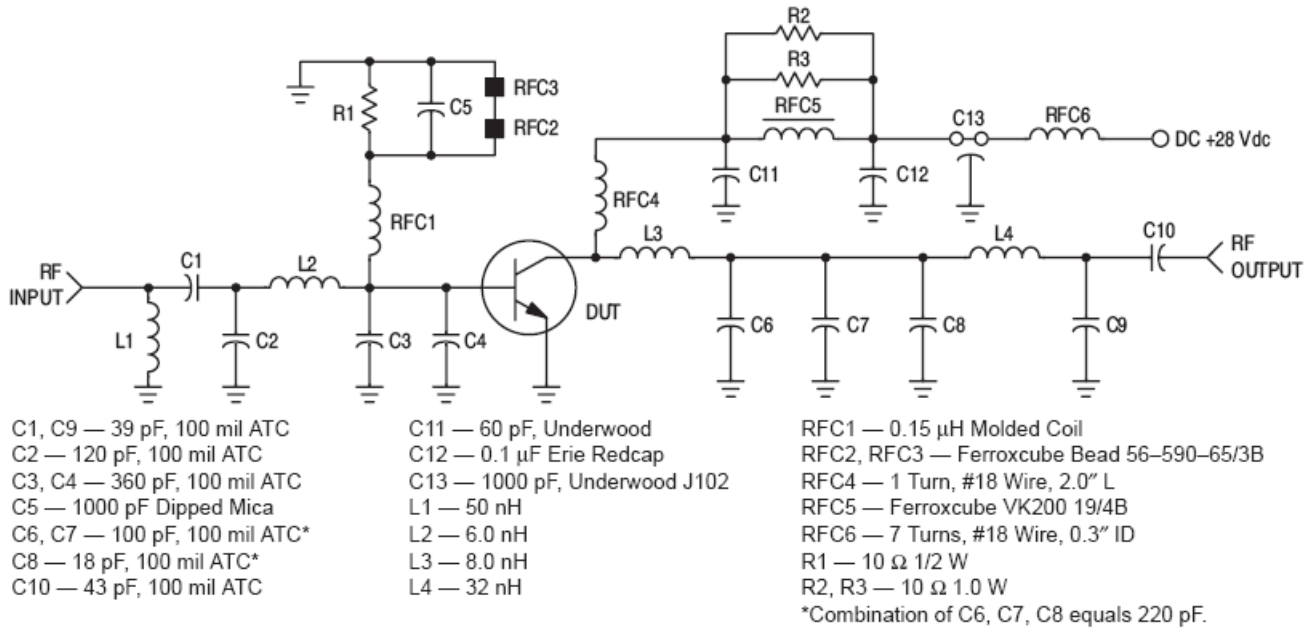

Figure 1. 110–160 MHz Broadband Amplifier — Test Fixture Schematic

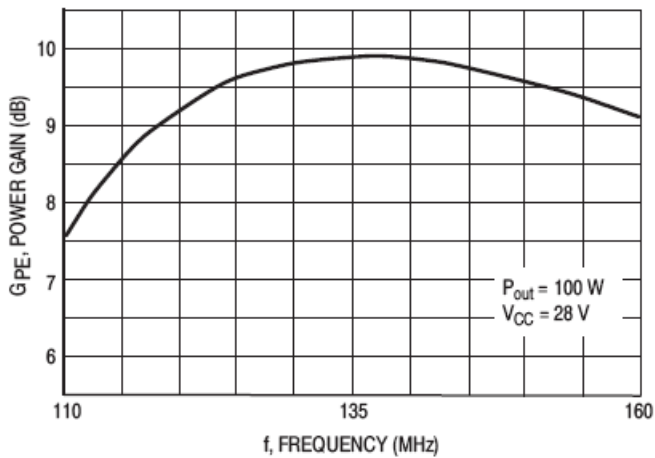

Figure 2. Power Gain versus Frequency  
Broadband Test Fixture

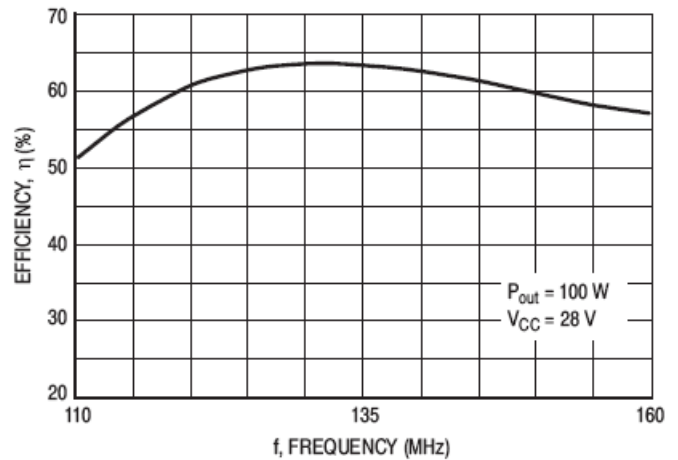

Figure 3. Efficiency versus Frequency  
Broadband Test Fixture

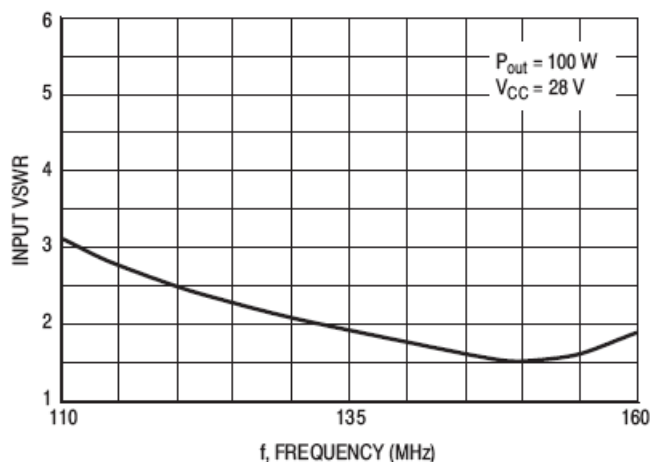

Figure 4. Input VSWR versus Frequency  
Broadband Test Fixture

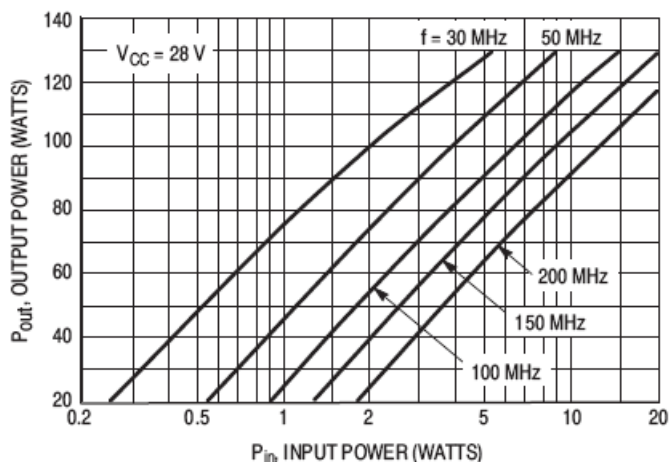

Figure 5. Output Power versus Input Power

### TYPICAL PERFORMANCE CURVES

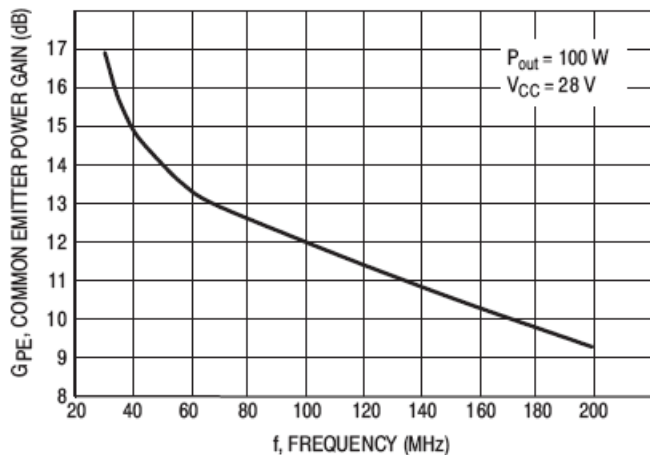

Figure 6. Power Gain versus Frequency

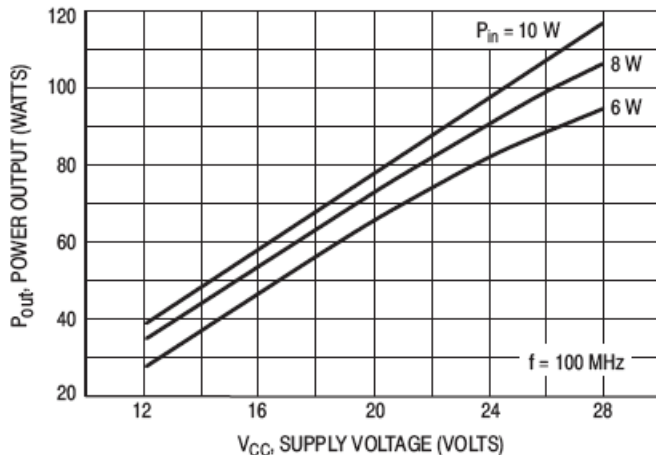

Figure 7. Power Output versus Supply Voltage

## The RF Line NPN Silicon Power Transistor 100W, 30-200MHz, 28V

Rev. V1

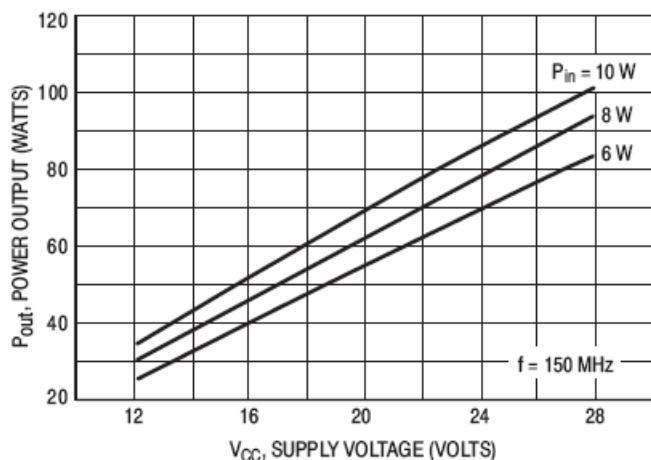

Figure 8. Power Output versus Supply Voltage

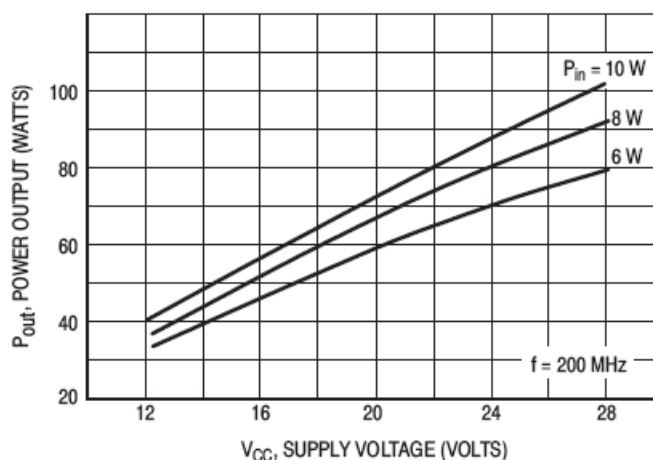
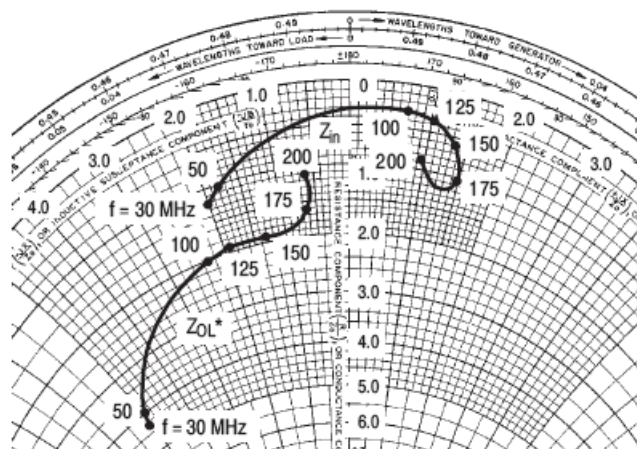

Figure 9. Power Output versus Supply Voltage



$V_{CC} = 28\text{ V}, P_{out} = 100\text{ W}$

f MHz	$Z_{in}$ OHMS	$Z_{OL}^*$ OHMS
30	1.2 - j2.0	4.3 - j5.0
50	1.0 - j1.8	4.0 - j4.9
100	0.3 + j0.7	2.0 - j2.3
125	0.3 + j1.0	1.9 - j1.9
150	0.6 + j1.3	1.9 - j1.3
175	1.0 + j1.5	1.6 - j0.6
200	0.9 + j1.0	1.1 - j0.6

$Z_{OL}^*$  = Conjugate of the optimum load impedance into which the device output operates at a given output power, voltage and frequency.

Figure 10. Series Equivalent Input-Output Impedance

## PACKAGE DIMENSIONS

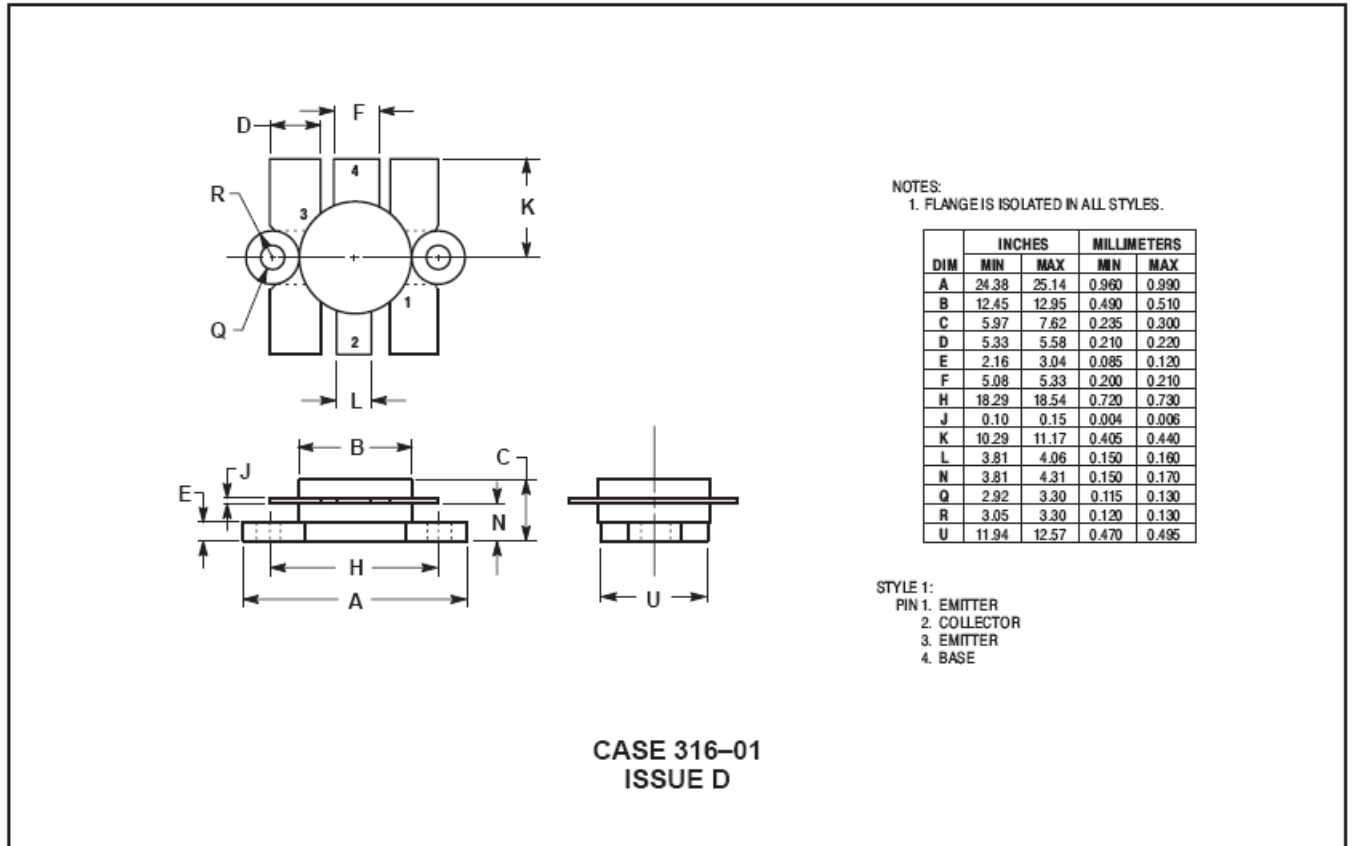

M/A-COM Technology Solutions Inc. All rights reserved.

Information in this document is provided in connection with M/A-COM Technology Solutions Inc ("MACOM") products. These materials are provided by MACOM as a service to its customers and may be used for informational purposes only. Except as provided in MACOM's Terms and Conditions of Sale for such products or in any separate agreement related to this document, MACOM assumes no liability whatsoever. MACOM assumes no responsibility for errors or omissions in these materials. MACOM may make changes to specifications and product descriptions at any time, without notice. MACOM makes no commitment to update the information and shall have no responsibility whatsoever for conflicts or incompatibilities arising from future changes to its specifications and product descriptions. No license, express or implied, by estoppel or otherwise, to any intellectual property rights is granted by this document.

THESE MATERIALS ARE PROVIDED "AS IS" WITHOUT WARRANTY OF ANY KIND, EITHER EXPRESS OR IMPLIED, RELATING TO SALE AND/OR USE OF MACOM PRODUCTS INCLUDING LIABILITY OR WARRANTIES RELATING TO FITNESS FOR A PARTICULAR PURPOSE, CONSEQUENTIAL OR INCIDENTAL DAMAGES, MERCHANTABILITY, OR INFRINGEMENT OF ANY PATENT, COPYRIGHT OR OTHER INTELLECTUAL PROPERTY RIGHT. MACOM FURTHER DOES NOT WARRANT THE ACCURACY OR COMPLETENESS OF THE INFORMATION, TEXT, GRAPHICS OR OTHER ITEMS CONTAINED WITHIN THESE MATERIALS. MACOM SHALL NOT BE LIABLE FOR ANY SPECIAL, INDIRECT, INCIDENTAL, OR CONSEQUENTIAL DAMAGES, INCLUDING WITHOUT LIMITATION, LOST REVENUES OR LOST PROFITS, WHICH MAY RESULT FROM THE USE OF THESE MATERIALS.

MACOM products are not intended for use in medical, lifesaving or life sustaining applications. MACOM customers using or selling MACOM products for use in such applications do so at their own risk and agree to fully indemnify MACOM for any damages resulting from such improper use or sale.

## Looking for pricing, stock, or lifecycle information?

Click below to explore more details on WIN SOURCE:

- ⊖ [View MRF317 on WIN SOURCE](#)
- ⊖ [M/A-Com Technology Solutions Information](#)

## Optimize Your Supply Chain with WIN SOURCE Solutions

- ✓ Global Sourcing Solution
- ✓ Obsolete Management
- ✓ Cost Control Management
- ✓ Shortage Management
- ✓ Alternative Solution
- ✓ Excess Inventory Management