



## The RF Line Controlled “Q” Broadband Power Transistor 80W, 100 to 500MHz, 28V

Rev. V1

Designed primarily for wideband large-signal output amplifier stages in the 100 to 500 MHz frequency range.

- Guaranteed performance @ 400 MHz, 28 Vdc  
Output power = 80 W over 225 to 400 MHz Band  
Minimum gain = 7.3 dB @ 400 MHz
- Built-in matching network for broadband operation using double match technique
- 100% tested for load mismatch at all phase angles with 30:1 VSWR
- Gold metallization system for high reliability applications
- Characterized for 100 – 500 MHz

### Product Image

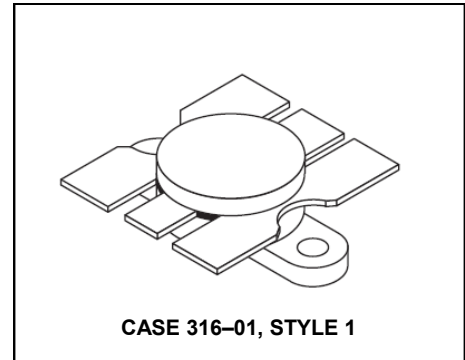

### MAXIMUM RATINGS

Rating	Symbol	Value	Unit
Collector-Emitter Voltage	$V_{CEO}$	33	Vdc
Collector-Base Voltage	$V_{CBO}$	60	Vdc
Emitter-Base Voltage	$V_{EBO}$	4.0	Vdc
Collector Current — Continuous — Peak	$I_C$	9.0 12	Adc
Total Device Dissipation @ $T_C = 25^\circ\text{C}$ (1) Derate above $25^\circ\text{C}$	$P_D$	250 1.43	Watts W/ $^\circ\text{C}$
Storage Temperature Range	$T_{stg}$	-65 to +150	$^\circ\text{C}$

### THERMAL CHARACTERISTICS

Characteristic	Symbol	Max	Unit
Thermal Resistance, Junction to Case	$R_{\theta JC}$	0.7	$^\circ\text{C}/\text{W}$

### ELECTRICAL CHARACTERISTICS ( $T_C = 25^\circ\text{C}$ unless otherwise noted.)

Characteristic	Symbol	Min	Typ	Max	Unit
----------------	--------	-----	-----	-----	------

### OFF CHARACTERISTICS

Collector-Emitter Breakdown Voltage ( $I_C = 80 \text{ mAdc}$ , $I_B = 0$ )	$V_{(BR)CEO}$	33	—	—	Vdc
Collector-Emitter Breakdown Voltage ( $I_C = 80 \text{ mAdc}$ , $V_{BE} = 0$ )	$V_{(BR)CES}$	60	—	—	Vdc
Emitter-Base Breakdown Voltage ( $I_E = 8.0 \text{ mAdc}$ , $I_C = 0$ )	$V_{(BR)EBO}$	4.0	—	—	Vdc
Collector-Base Breakdown Voltage ( $I_C = 80 \text{ mAdc}$ , $I_C = 0$ )	$V_{(BR)CBO}$	60	—	—	Vdc
Collector Cutoff Current ( $V_{CB} = 30 \text{ Vdc}$ , $I_E = 0$ )	$I_{CBO}$	—	—	5.0	mAdc

### ON CHARACTERISTICS

DC Current Gain ( $I_C = 4.0 \text{ Adc}$ , $V_{CE} = 5.0 \text{ Vdc}$ )	$h_{FE}$	20	—	80	—
--	----------	----	---	----	---

NOTE:

1. This device is designed for RF operation. The total device dissipation rating applies only when the device is operated as an RF amplifier. (continued)

## The RF Line Controlled “Q” Broadband Power Transistor 80W, 100 to 500MHz, 28V

Rev. V1

### DYNAMIC CHARACTERISTICS

Output Capacitance ( $V_{CB} = 28 \text{ Vdc}$ , $I_E = 0$ , $f = 1.0 \text{ MHz}$ )	$C_{ob}$	—	95	125	pF
---	----------	---	----	-----	----

### ELECTRICAL CHARACTERISTICS – continued ( $T_C = 25^\circ\text{C}$ unless otherwise noted.)

Characteristic	Symbol	Min	Typ	Max	Unit
----------------	--------	-----	-----	-----	------

### FUNCTIONAL TESTS (Figure 1)

Common-Emitter Amplifier Power Gain ( $V_{CC} = 28 \text{ Vdc}$ , $P_{out} = 80 \text{ W}$ , $f = 400 \text{ MHz}$ )	$G_{PE}$	7.3	9.0	—	dB
Collector Efficiency ( $V_{CC} = 28 \text{ Vdc}$ , $P_{out} = 80 \text{ W}$ , $f = 400 \text{ MHz}$ )	$\eta$	50	60	—	%
Load Mismatch ( $V_{CC} = 28 \text{ Vdc}$ , $P_{out} = 80 \text{ W}$ , $f = 400 \text{ MHz}$ , VSWR = 30:1 All Phase Angles)	$\psi$	No Degradation in Output Power			

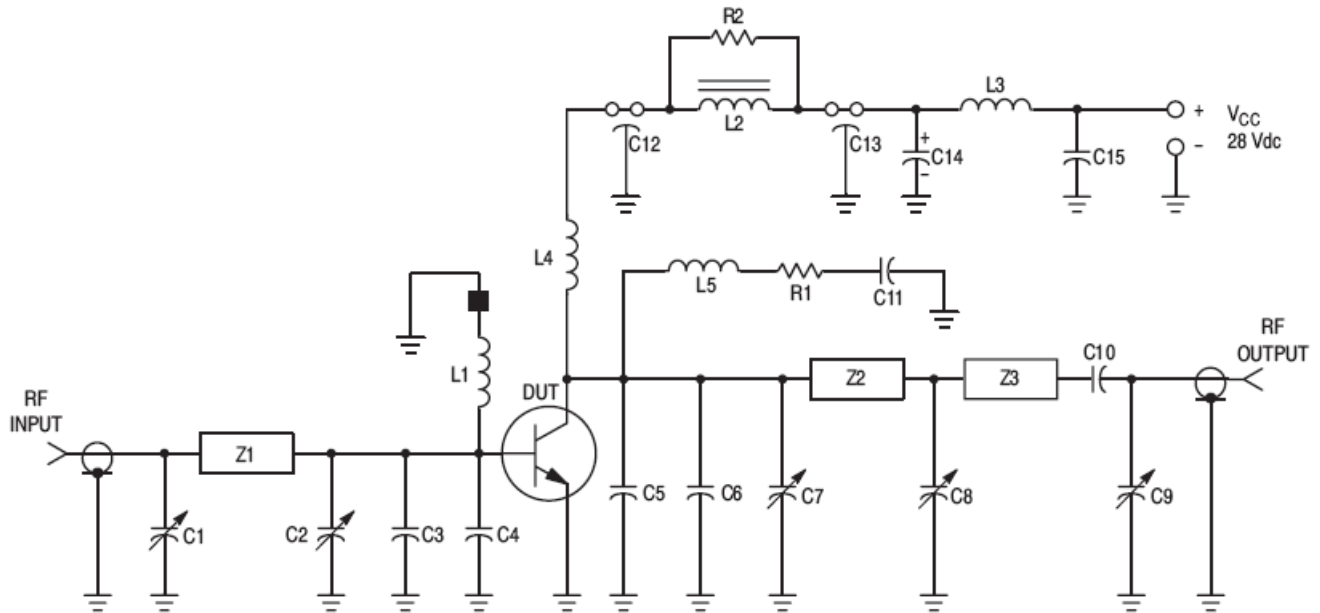

C1, C2, C7, C8, C9 — 1.0–20 pF Piston Trimmer (Johanson JMC 5501)  
 C3, C4 — 36 pF ATC 100 mil Chip Capacitor  
 C5, C6 — 43 pF ATC 100 mil Chip Capacitor  
 C10 — 100 pF UNELCO  
 C11, C15 — 0.1  $\mu\text{F}$  Erie Redcap  
 C12, C13 — 680 pF Feedthru  
 C14 — 1.0  $\mu\text{F}$  50 V Tantalum  
 L1 — 4 Turns #22 AWG Enameled, 3/16" ID Closewound with Ferroxcube Bead (#56–590–65/4B) on Ground End of Coil  
 L2 — Ferroxcube VK200–19/4B Ferrite Choke  
 L3 — 7 Turns #18 AWG, 11/16" Long, Wound on a 100 k $\Omega$  2.0 Watt Resistor

L4 — 6 Turns #20 AWG Enameled, 3/16" ID Closewound  
 L5 — 4 Turns #22 AWG Enameled, 1/8" ID Closewound  
 Z1 — Microstrip 0.2" W x 1.5" L  
 Z2 — Microstrip 0.17" W x 1.16" L  
 Z3 — Microstrip 0.17" W x 0.63" L  
 R1, R2 — 10  $\Omega$  2.0 Watt  
 Board — Glass Teflon  $\epsilon_r = 2.56$ ,  $t = 0.062$ "  
 Input/Output Connectors Type N  
 DUT Socket Lead Frame Etched from 80–mil–Thick Copper

Figure 1. 400 MHz Test Circuit

## The RF Line Controlled "Q" Broadband Power Transistor 80W, 100 to 500MHz, 28V

Rev. V1

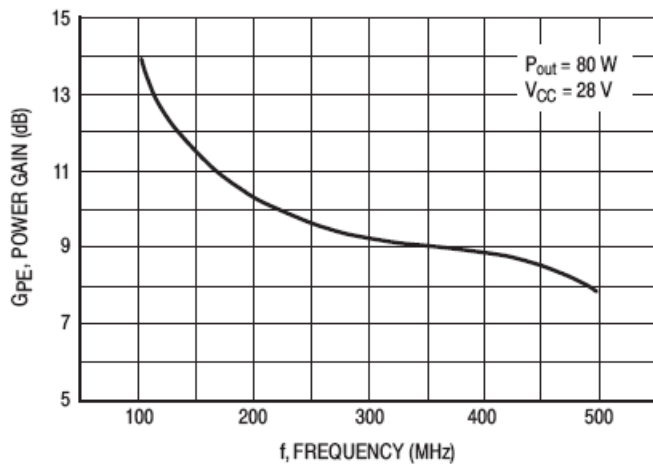

Figure 2. Power Gain versus Frequency

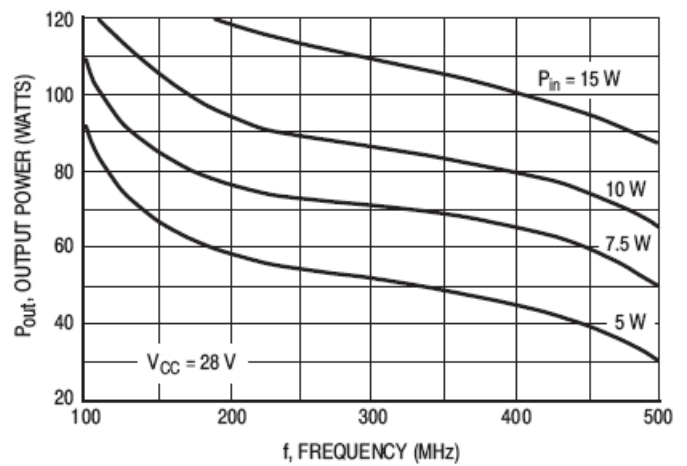

Figure 3. Output Power versus Frequency

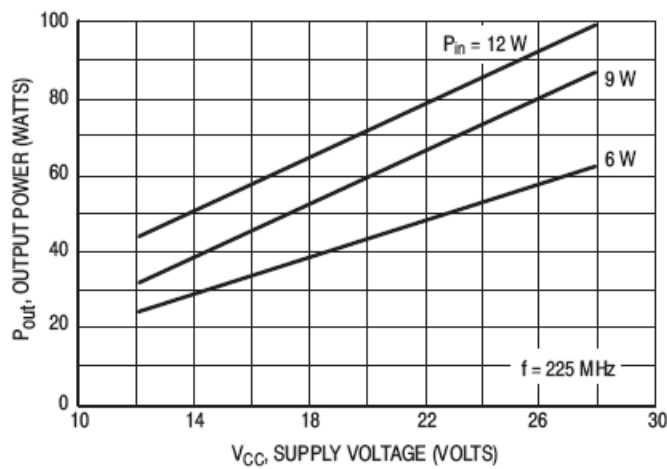

Figure 4. Output Power versus Supply Voltage

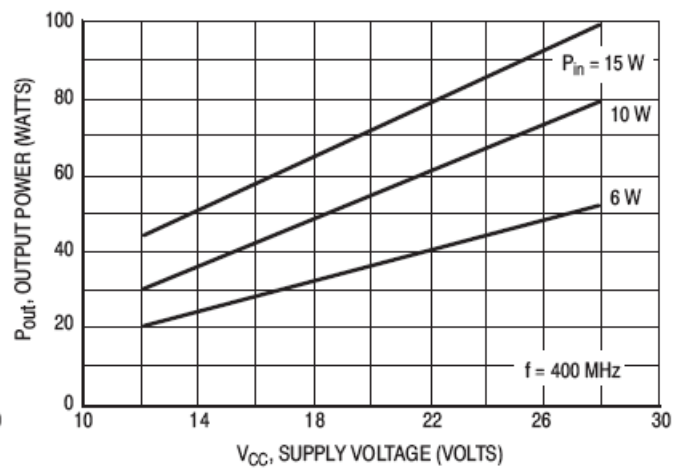

Figure 5. Output Power versus Supply Voltage

## The RF Line Controlled "Q" Broadband Power Transistor 80W, 100 to 500MHz, 28V

Rev. V1

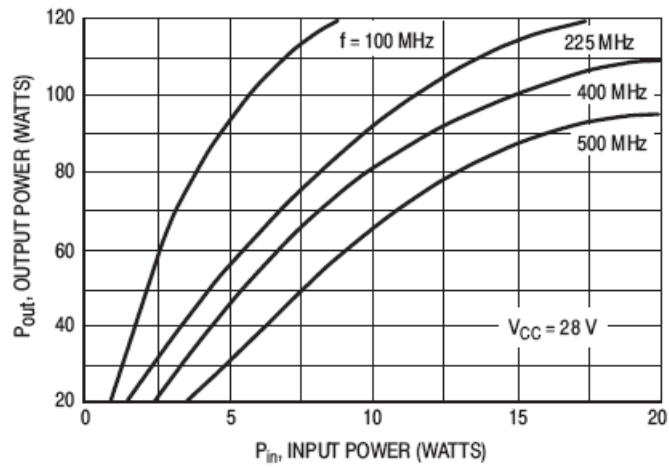

Figure 6. Output Power versus Input Power

## The RF Line Controlled “Q” Broadband Power Transistor 80W, 100 to 500MHz, 28V

Rev. V1

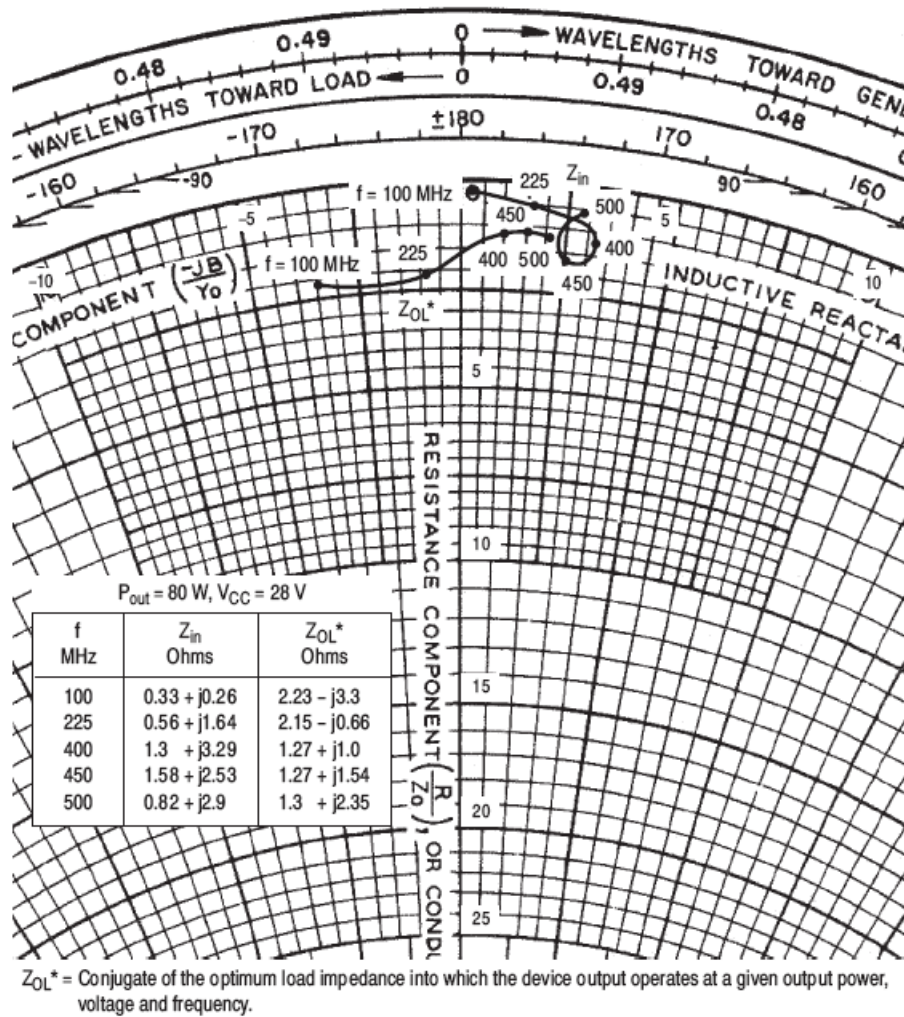
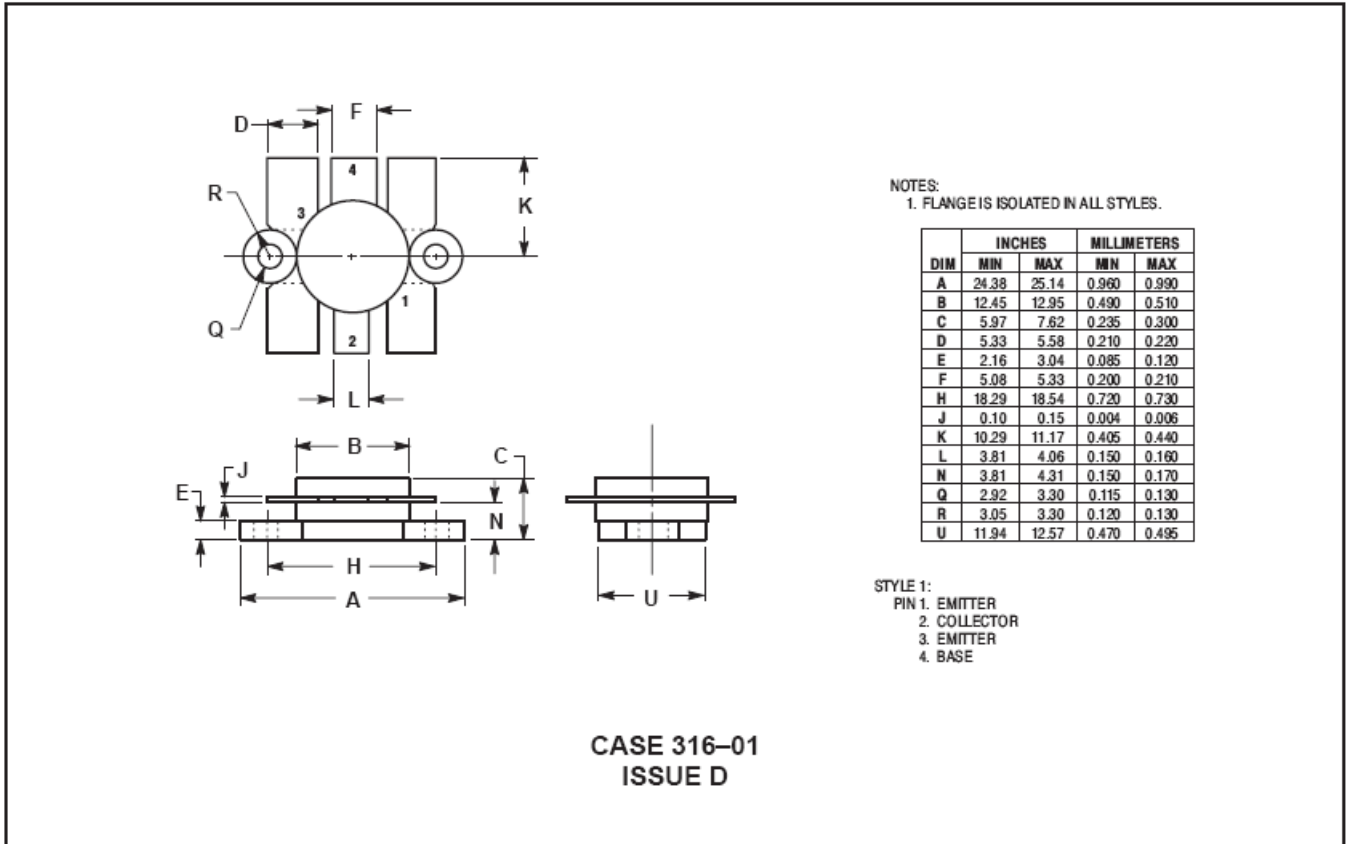

Figure 7. Series Equivalent Input-Output Impedance

## The RF Line Controlled "Q" Broadband Power Transistor 80W, 100 to 500MHz, 28V

Rev. V1

### PACKAGE DIMENSIONS



M/A-COM Technology Solutions Inc. All rights reserved.

Information in this document is provided in connection with M/A-COM Technology Solutions Inc ("MACOM") products. These materials are provided by MACOM as a service to its customers and may be used for informational purposes only. Except as provided in MACOM's Terms and Conditions of Sale for such products or in any separate agreement related to this document, MACOM assumes no liability whatsoever. MACOM assumes no responsibility for errors or omissions in these materials. MACOM may make changes to specifications and product descriptions at any time, without notice. MACOM makes no commitment to update the information and shall have no responsibility whatsoever for conflicts or incompatibilities arising from future changes to its specifications and product descriptions. No license, express or implied, by estoppel or otherwise, to any intellectual property rights is granted by this document.

THESE MATERIALS ARE PROVIDED "AS IS" WITHOUT WARRANTY OF ANY KIND, EITHER EXPRESS OR IMPLIED, RELATING TO SALE AND/OR USE OF MACOM PRODUCTS INCLUDING LIABILITY OR WARRANTIES RELATING TO FITNESS FOR A PARTICULAR PURPOSE, CONSEQUENTIAL OR INCIDENTAL DAMAGES, MERCHANTABILITY, OR INFRINGEMENT OF ANY PATENT, COPYRIGHT OR OTHER INTELLECTUAL PROPERTY RIGHT. MACOM FURTHER DOES NOT WARRANT THE ACCURACY OR COMPLETENESS OF THE INFORMATION, TEXT, GRAPHICS OR OTHER ITEMS CONTAINED WITHIN THESE MATERIALS. MACOM SHALL NOT BE LIABLE FOR ANY SPECIAL, INDIRECT, INCIDENTAL, OR CONSEQUENTIAL DAMAGES, INCLUDING WITHOUT LIMITATION, LOST REVENUES OR LOST PROFITS, WHICH MAY RESULT FROM THE USE OF THESE MATERIALS.

MACOM products are not intended for use in medical, lifesaving or life sustaining applications. MACOM customers using or selling MACOM products for use in such applications do so at their own risk and agree to fully indemnify MACOM for any damages resulting from such improper use or sale.

## Looking for pricing, stock, or lifecycle information?

Click below to explore more details on WIN SOURCE:

- ⊖ [View MRF327 on WIN SOURCE](#)
- ⊖ [M/A-Com Technology Solutions](#) Information

## Optimize Your Supply Chain with WIN SOURCE Solutions

- ✓ Global Sourcing Solution
- ✓ Obsolete Management
- ✓ Cost Control Management
- ✓ Shortage Management
- ✓ Alternative Solution
- ✓ Excess Inventory Management