



# THE DATASHEET OF MRF372R5



# RF Power Field-Effect Transistor

## N-Channel Enhancement-Mode Lateral MOSFET

Designed for broadband commercial and industrial applications with frequencies from 470 to 860 MHz. The high gain and broadband performance of this device make it ideal for large-signal, common source amplifier applications in 32 volt transmitter equipment.

- Typical Narrowband Two-Tone Performance @ f1 = 857 MHz, f2 = 863 MHz, 32 Volts  
 Output Power — 180 Watts PEP  
 Power Gain — 17 dB  
 Efficiency — 36%  
 IMD — -35 dBc
- Typical Broadband Two-Tone Performance @ f1 = 857 MHz, f2 = 863 MHz, 32 Volts  
 Output Power — 180 Watts PEP  
 Power Gain — 14.5 dB  
 Efficiency — 37%  
 IMD — -31 dBc
- Capable of Handling 3:1 VSWR @ 32 Vdc, 857 MHz, 90 Watts CW Output Power

### Features

- Internally Matched for Ease of Use
- Integrated ESD Protection
- Excellent Thermal Stability
- Characterized with Series Equivalent Large-Signal Impedance Parameters
- RoHS Compliant
- In Tape and Reel. R3 Suffix = 250 Units per 56 mm, 13 inch Reel.  
 R5 Suffix = 50 Units per 56 mm, 13 inch Reel.

**MRF372R3**  
**MRF372R5**

**470-860 MHz, 180 W, 32 V**  
**LATERAL N-CHANNEL**  
**RF POWER MOSFET**

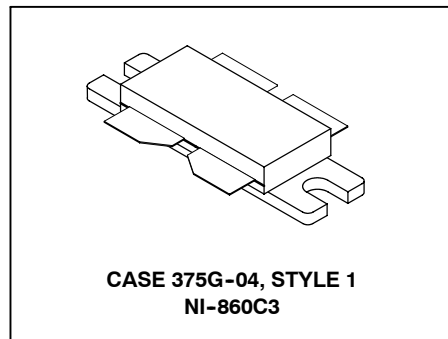

ARCHIVE INFORMATION

ARCHIVE INFORMATION

**Table 1. Maximum Ratings**

Rating	Symbol	Value	Unit
Drain-Source Voltage	V <sub>DSS</sub>	-0.5, +68	Vdc
Gate-Source Voltage	V <sub>GS</sub>	-0.5, +15	Vdc
Drain Current - Continuous	I <sub>D</sub>	17	Adc
Total Device Dissipation @ T <sub>C</sub> = 25°C Derate above 25°C	P <sub>D</sub>	350 2.0	W W/°C
Storage Temperature Range	T <sub>stg</sub>	-65 to +150	°C
Case Operating Temperature	T <sub>C</sub>	150	°C
Operating Junction Temperature	T <sub>J</sub>	200	°C

**Table 2. Thermal Characteristics**

Characteristic	Symbol	Value	Unit
Thermal Resistance, Junction to Case	R <sub>θJC</sub>	0.5	°C/W

**Table 3. ESD Protection Characteristics**

Test Conditions	Class
Human Body Model	1 (Minimum)
Machine Model	M3 (Minimum)

**Table 4. Electrical Characteristics** ( $T_C = 25^\circ\text{C}$  unless otherwise noted)

Characteristic	Symbol	Min	Typ	Max	Unit
<b>Off Characteristics</b> <sup>(1)</sup>					
Drain-Source Breakdown Voltage ( $V_{GS} = 0\text{ Vdc}$ , $I_D = 10\ \mu\text{A}$ )	$V_{(BR)DSS}$	68	—	—	Vdc
Zero Gate Voltage Drain Current ( $V_{DS} = 32\text{ Vdc}$ , $V_{GS} = 0\text{ Vdc}$ )	$I_{DSS}$	—	—	10	$\mu\text{Adc}$
Gate-Source Leakage Current ( $V_{GS} = 5\text{ Vdc}$ , $V_{DS} = 0\text{ Vdc}$ )	$I_{GSS}$	—	—	1	$\mu\text{Adc}$
<b>On Characteristics</b>					
Gate Threshold Voltage <sup>(1)</sup> ( $V_{DS} = 10\text{ V}$ , $I_D = 200\ \mu\text{A}$ )	$V_{GS(th)}$	2	3	4	Vdc
Gate Quiescent Voltage <sup>(2)</sup> ( $V_{DS} = 32\text{ V}$ , $I_D = 100\text{ mA}$ )	$V_{GS(Q)}$	2.5	3.5	4.5	Vdc
Drain-Source On-Voltage <sup>(1)</sup> ( $V_{GS} = 10\text{ V}$ , $I_D = 3\text{ A}$ )	$V_{DS(on)}$	—	0.28	0.45	Vdc
Forward Transconductance ( $V_{DS} = 10\text{ V}$ , $I_D = 3\text{ A}$ )	$g_{fs}$	—	2.6	—	S
<b>Dynamic Characteristics</b> <sup>(1)</sup>					
Input Capacitance (Includes Input Matching Capacitance) ( $V_{DS} = 32\text{ V}$ , $V_{GS} = 0\text{ V}$ , $f = 1\text{ MHz}$ )	$C_{iss}$	—	260	—	pF
Output Capacitance ( $V_{DS} = 32\text{ V}$ , $V_{GS} = 0\text{ V}$ , $f = 1\text{ MHz}$ )	$C_{oss}$	—	69	—	pF
Reverse Transfer Capacitance ( $V_{DS} = 32\text{ V}$ , $V_{GS} = 0\text{ V}$ , $f = 1\text{ MHz}$ )	$C_{rss}$	—	2.5	—	pF
<b>Functional Characteristics, Narrowband Operation</b> <sup>(2)</sup> (In Freescale MRF372 Narrowband Circuit, 50 ohm system)					
Common Source Power Gain ( $V_{DD} = 32\text{ V}$ , $P_{out} = 180\text{ W PEP}$ , $I_{DQ} = 800\text{ mA}$ , $f_1 = 857\text{ MHz}$ , $f_2 = 863\text{ MHz}$ )	$G_{ps}$	16	17	—	dB
Drain Efficiency ( $V_{DD} = 32\text{ V}$ , $P_{out} = 180\text{ W PEP}$ , $I_{DQ} = 800\text{ mA}$ , $f_1 = 857\text{ MHz}$ , $f_2 = 863\text{ MHz}$ )	$\eta$	33	36	—	%
Intermodulation Distortion ( $V_{DD} = 32\text{ Vdc}$ , $P_{out} = 180\text{ W PEP}$ , $I_{DQ} = 800\text{ mA}$ , $f_1 = 857\text{ MHz}$ , $f_2 = 863\text{ MHz}$ )	IMD	—	-35	-31	dBc
<b>Typical Characteristics, Broadband Operation</b> <sup>(2)</sup> (In Freescale MRF372 Broadband Circuit, 50 ohm system)					
Common Source Power Gain ( $V_{DD} = 32\text{ Vdc}$ , $P_{out} = 180\text{ W PEP}$ , $I_{DQ} = 1000\text{ mA}$ , $f_1 = 857\text{ MHz}$ , $f_2 = 863\text{ MHz}$ )	$G_{ps}$	—	14.5	—	dB
Drain Efficiency ( $V_{DD} = 32\text{ Vdc}$ , $P_{out} = 180\text{ W PEP}$ , $I_{DQ} = 1000\text{ mA}$ , $f_1 = 857\text{ MHz}$ , $f_2 = 863\text{ MHz}$ )	$\eta$	—	37	—	%
Intermodulation Distortion ( $V_{DD} = 32\text{ Vdc}$ , $P_{out} = 180\text{ W PEP}$ , $I_{DQ} = 1000\text{ mA}$ , $f_1 = 857\text{ MHz}$ , $f_2 = 863\text{ MHz}$ )	IMD	—	-31	—	dBc

1. Each side of device measured separately.
2. Measurement made with device in push-pull configuration.

### TYPICAL CHARACTERISTICS

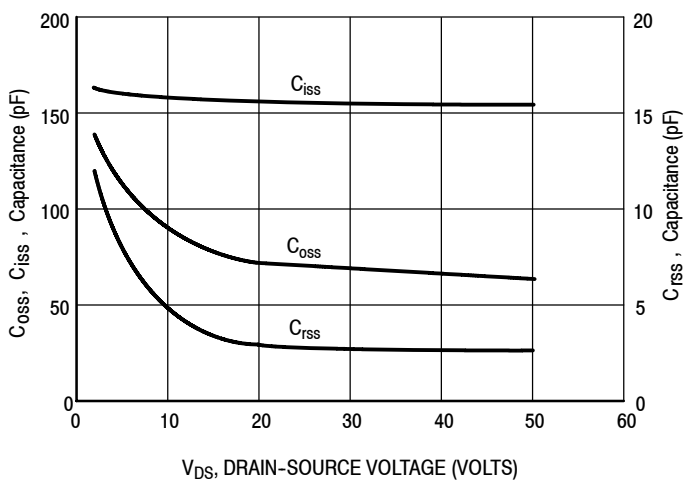

Note:  $C_{iss}$  does not include input matching capacitance.

**Figure 1. Capacitance versus Voltage**

ARCHIVE INFORMATION

ARCHIVE INFORMATION

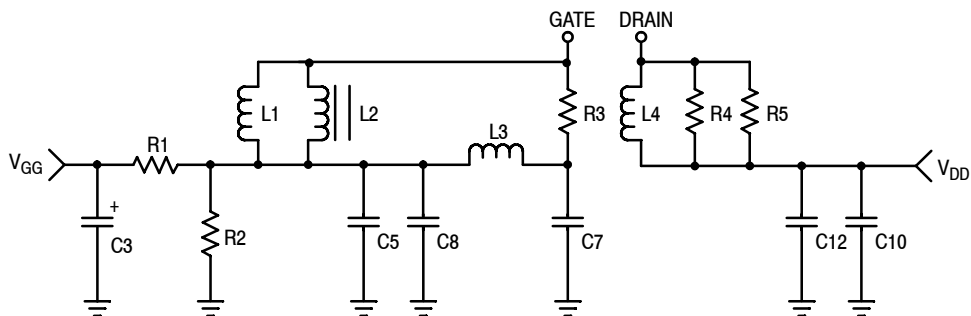

Figure 2. 860 MHz Narrowband DC Bias Networks

Table 5. 860 MHz Narrowband DC Bias Networks Component Designations and Values

Designation	Description
C1	2.2 pF Chip Capacitor, ATC
C2	0.5 — 5.0 pF Variable Capacitor, Johansen Gigatrim
C3A, B	22 $\mu$ F, 22 V Tantalum Chip Capacitors, Kemet #T491D226K22AS
C4A, B, C14A, B	47.0 pF Chip Capacitors, ATC
C5A, B	100 pF Chip Capacitors, ATC
C6	10.0 pF Chip Capacitor, ATC
C7A, B	2.7 pF Chip Capacitors, ATC
C8A, B	1.0 $\mu$ F, 100 V Chip Capacitors, Vitramon #VJ3640Y105KXBAT
C9	10.0 pF Chip Capacitor, ATC
C10A, B	2.2 $\mu$ F, 100 V Chip Capacitors, Vitramon #VJ3640Y225KXBAT
C11	5.1 pF Chip Capacitor, ATC
C12A, B	0.01 $\mu$ F, 100 V Chip Capacitors, Kemet #VJ1210Y103KXBAT
C13	3.9 pF Chip Capacitor, ATC
C15	1.2 pF Chip Capacitor, ATC
L1A, B	130 nH, Coilcraft #132-11SM
L2A, B	#24 AWG, 3 Turns Loose, Fair Rite #2643706001
L3A, B	3.85 nH, Coilcraft #0906-4
L4A, B	5.0 nH, Coilcraft #A02T
R1A, B, R2A, B R4A, B, R5A, B	180 $\Omega$ , 1/4 W Chip Resistors, Vishay Dale (1210)
R3A, B	12 $\Omega$ , 1/8 W Chip Resistors, Vishay Dale (1206)
PCB	MRF372 Printed Circuit Board Rev 1a, Rogers RO4350, Height 30 mils, $\epsilon_r = 3.48$
Balun A, B	Vertical 860 MHz Broadband Balun, Printed Circuit Board Rev 01, Rogers RO3010, Height 50 mils, $\epsilon_r = 10.2$

ARCHIVE INFORMATION

ARCHIVE INFORMATION

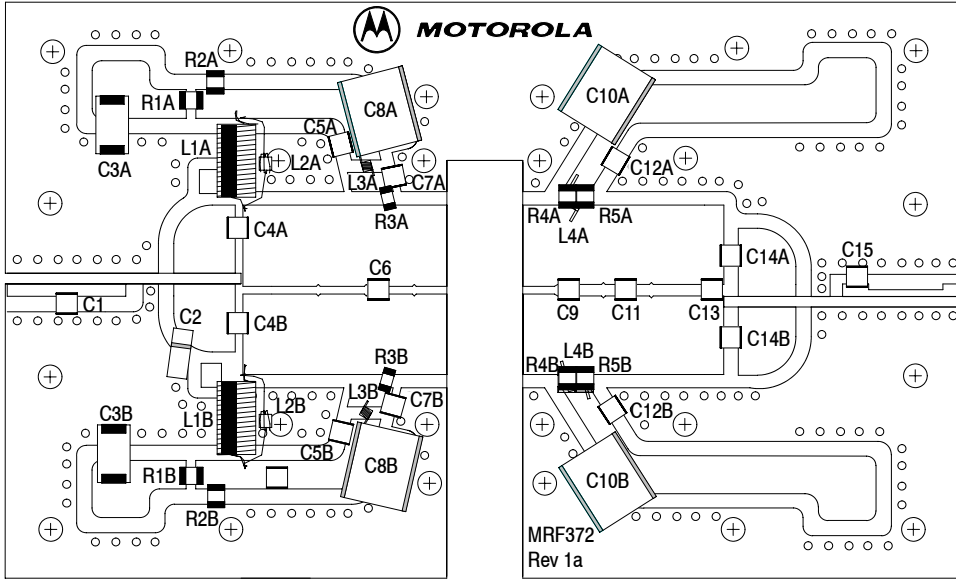

**Vertical Balun Mounting Detail**

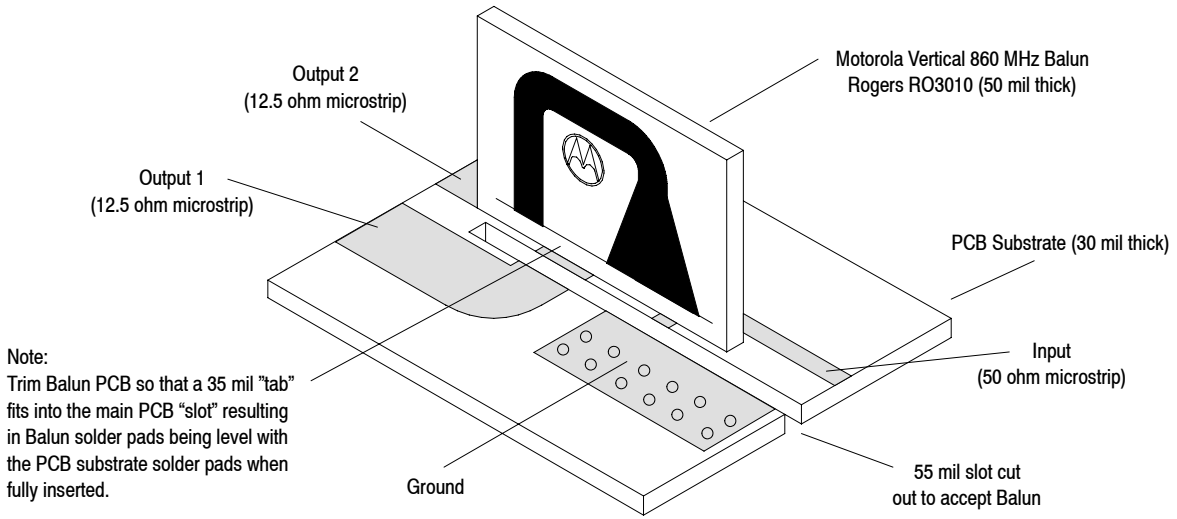

Freescale has begun the transition of marking Printed Circuit Boards (PCBs) with the Freescale Semiconductor signature/logo. PCBs may have either Motorola or Freescale markings during the transition period. These changes will have no impact on form, fit or function of the current product.

**Figure 3. 860 MHz Narrowband Component Layout**

## TYPICAL TWO-TONE NARROWBAND CHARACTERISTICS

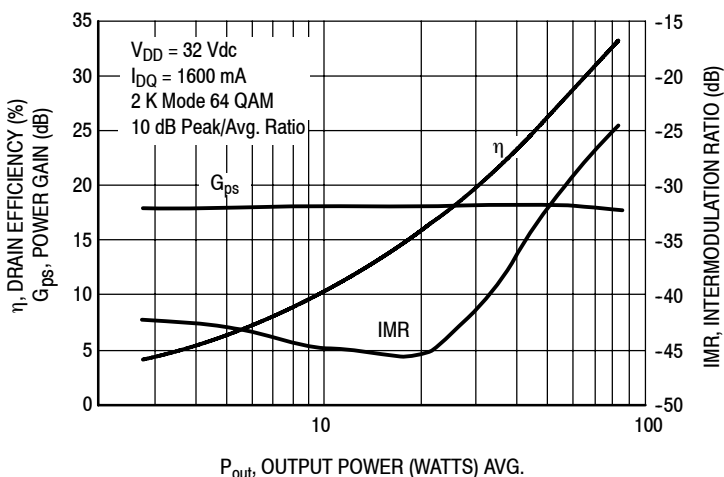

Note: IMR measured using Delta Marker Method.

Figure 4. COFDM Performance (860 MHz)

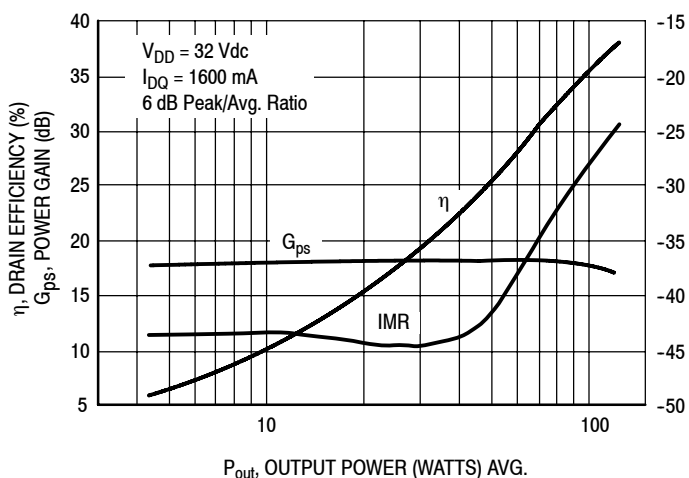

Note: IMR measured using Delta Marker Method.

Figure 5. 8-VSB Performance (860 MHz)

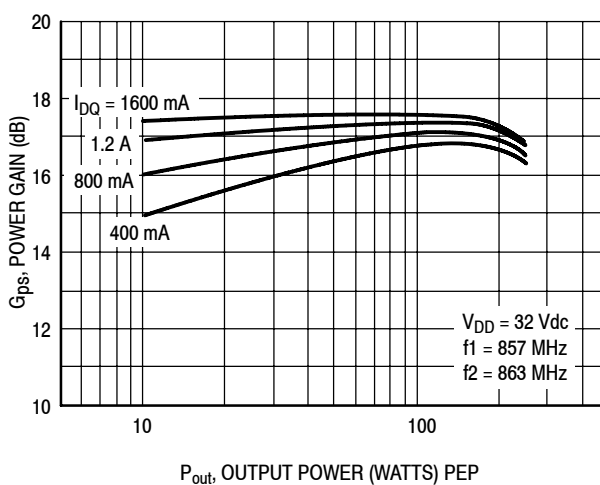

Figure 6. Power Gain versus Output Power

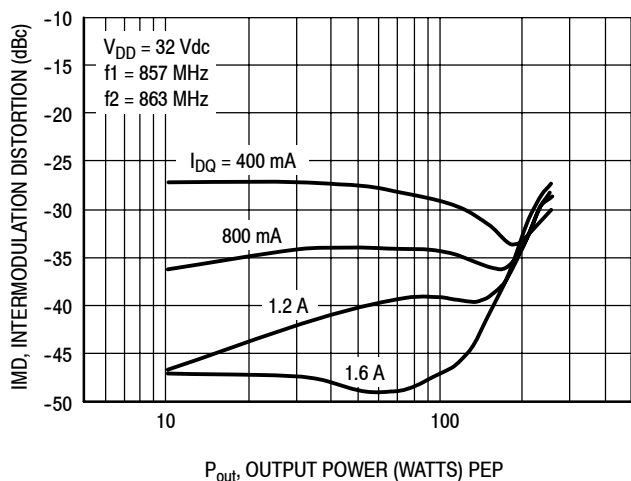

Figure 7. Intermodulation Distortion versus Output Power

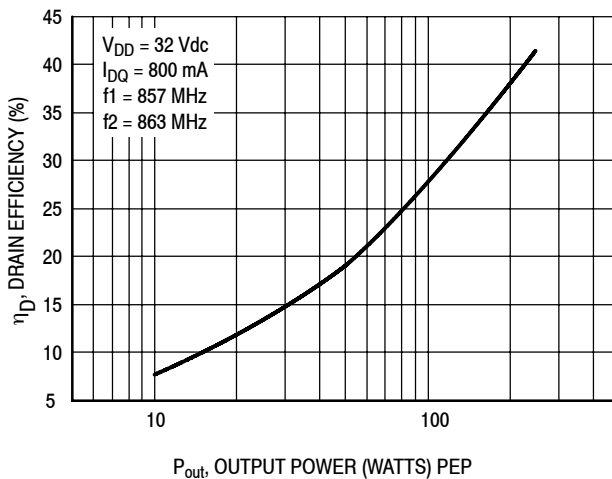
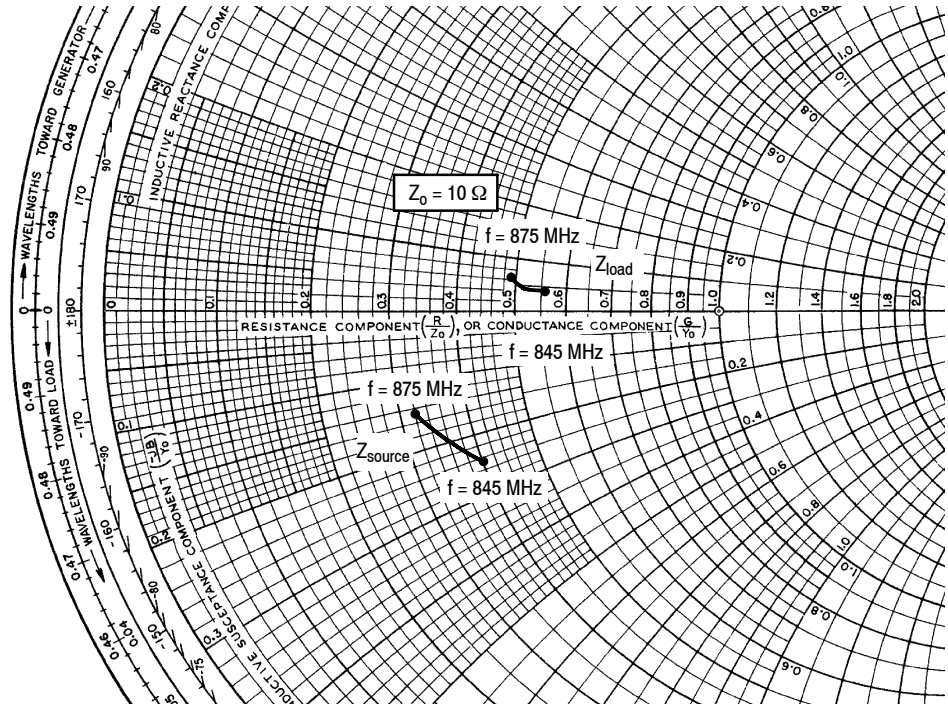

Figure 8. Drain Efficiency versus Output Power



$V_{DD} = 32\text{ V}$ ,  $I_{DQ} = 800\text{ mA}$ ,  $P_{out} = 180\text{ W PEP}$

f MHz	$Z_{source}$ $\Omega$	$Z_{load}$ $\Omega$
845	$3.99 - j2.50$	$5.63 + j0.38$
860	$3.56 - j1.98$	$5.28 + j0.43$
875	$3.18 - j1.46$	$4.94 + j0.56$
Harmonics		
f GHz	$Z_{source}$ $\Omega$	$Z_{load}$ $\Omega$
1.69	$2.85 + j14.30$	$1.23 + j9.37$
1.72	$3.27 + j14.32$	$1.54 + j9.60$
1.75	$3.35 + j14.36$	$1.73 + j9.62$

$Z_{source}$  = Test circuit impedance as measured from gate to gate, balanced configuration.

$Z_{load}$  = Test circuit impedance as measured from drain to drain, balanced configuration.

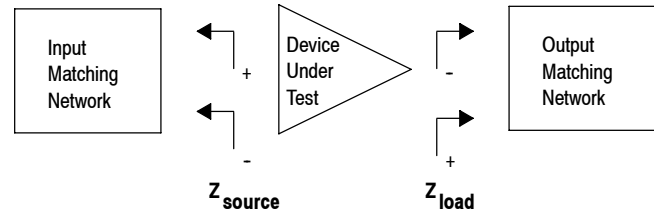

Figure 9. Narrowband Series Equivalent Source and Load Impedance

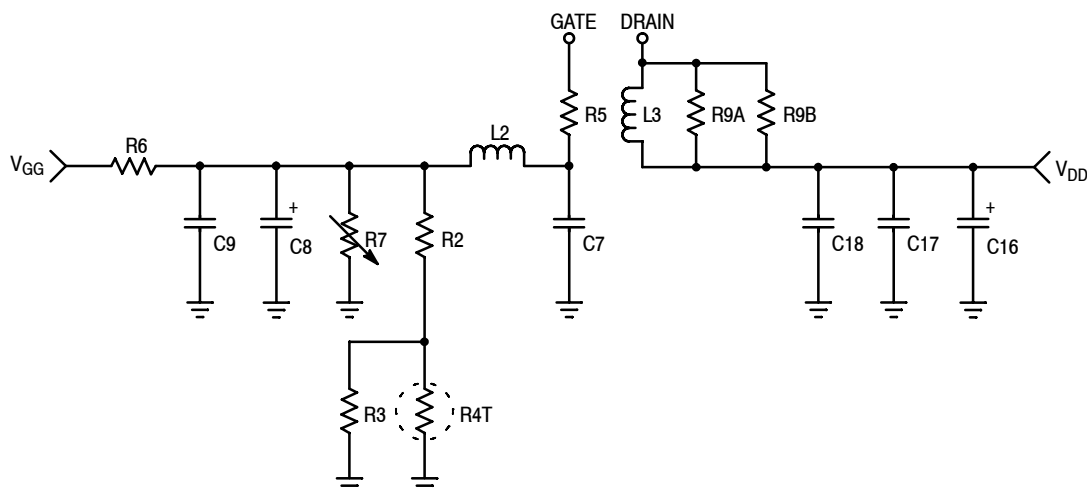
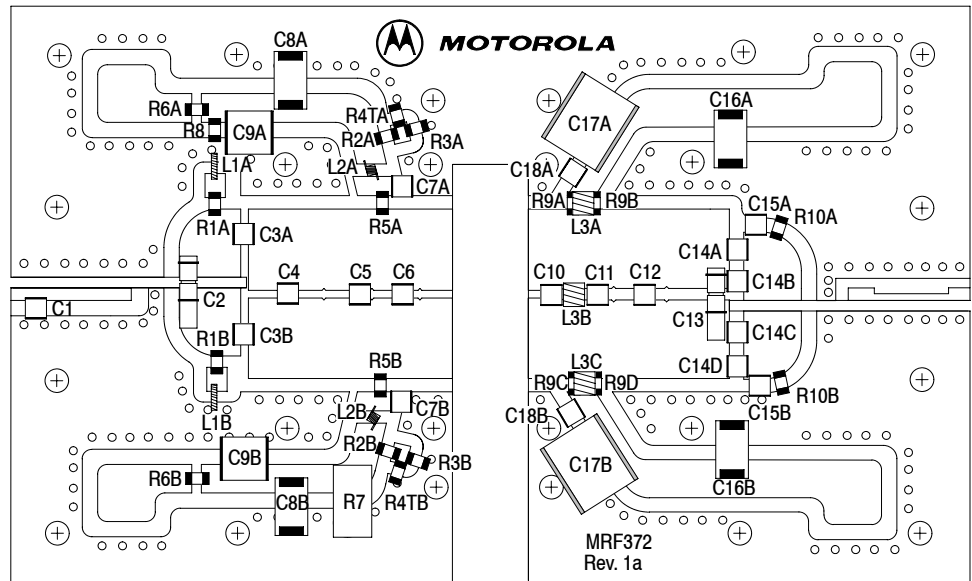

Figure 10. 470-860 MHz Broadband DC Bias Networks

Table 6. 470-860 MHz Broadband DC Bias Networks Component Designations and Values

Designation	Description
C1	0.7 pF Chip Capacitor, ATC
C2, C13	0.8 — 8.0 pF Variable Capacitors, Johansen Gigatrim
C3A, B, C14A, B, C, D	100 pF Chip Capacitors, ATC
C4	4.7 pF, Chip Capacitor, ATC
C5	7.5 pF Chip Capacitor, ATC
C6	10.0 pF Chip Capacitor, ATC
C7A, B	6.2 pF Chip Capacitors, ATC
C8A, B	22 $\mu$ F, 22 V Tantalum Chip Capacitors, Kemet #T491D226K22AS
C9A, B	0.1 $\mu$ F, 100 V Chip Capacitors, Vitramon #VJ3640Y104KXBAT
C10	13 pF Chip Capacitor, ATC
C11	6.8 pF Chip Capacitor, ATC
C12	3.9 pF Chip Capacitor, ATC
C15A, B	3.3 pF Chip Capacitors, ATC
C16A, B	10 $\mu$ F, 35 V Tantalum Chip Capacitors, Kemet #T491D106K35AS
C17A, B	3.3 $\mu$ F, 100 V Chip Capacitors, Vitramon #VJ3640Y335KXBAT
C18A, B	0.01 $\mu$ F Chip Capacitors, ATC
L1A, B	12.55 nH, Coilcraft #1606-10
L2A, B	5.45 nH, Coilcraft #0906-5
L3A, B, C	12.5 nH, Coilcraft #A04T
R1A, B	10 $\Omega$ , 1/4 W Chip Resistors, Vishay Dale (1210)
R2A, B	2.2 k $\Omega$ , 1/4 W Chip Resistors, Vishay Dale (1210)
R3A, B, R10A, B	390 $\Omega$ , 1/8 W Chip Resistors, Vishay Dale (1206)
R4TA, B	520 $\Omega$ , Thermistor, Vishay #NTHS—1206J14520R5%
R5A, B	6.2 $\Omega$ , 1/4 W Chip Resistors, Vishay Dale (1210)
R6A, B	6.8 k $\Omega$ , 1/4 W Chip Resistors, Vishay Dale (1210)
R7	100 k $\Omega$ Potentiometer, Bourns
R8	47.3 k $\Omega$ , 1/8 W Chip Resistor, Vishay Dale (1206)
R9A, B, C, D	180 $\Omega$ , 1/4 W Chip Resistors, Vishay Dale (1210)
PCB	MRF372 Printed Circuit Board Rev 1a, Rogers RO4350, Height 30 mils, $\epsilon_r = 3.48$
Balun A, B	Vertical 660 MHz Broadband Balun, Printed Circuit Board Rev 01, Rogers RO3010, Height 50 mils, $\epsilon_r = 10.2$



### Vertical Balun Mounting Detail

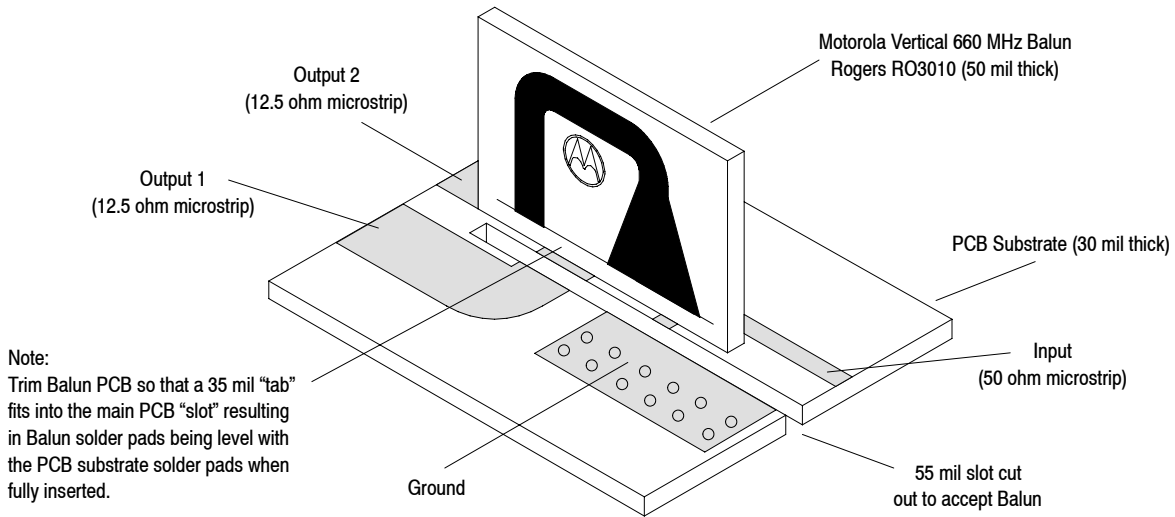

Freeseale has begun the transition of marking Printed Circuit Boards (PCBs) with the Freeseale Semiconductor signature/logo. PCBs may have either Motorola or Freeseale markings during the transition period. These changes will have no impact on form, fit or function of the current product.

**Figure 11. 470–860 MHz Broadband Component Layout**

## TYPICAL TWO-TONE BROADBAND CHARACTERISTICS

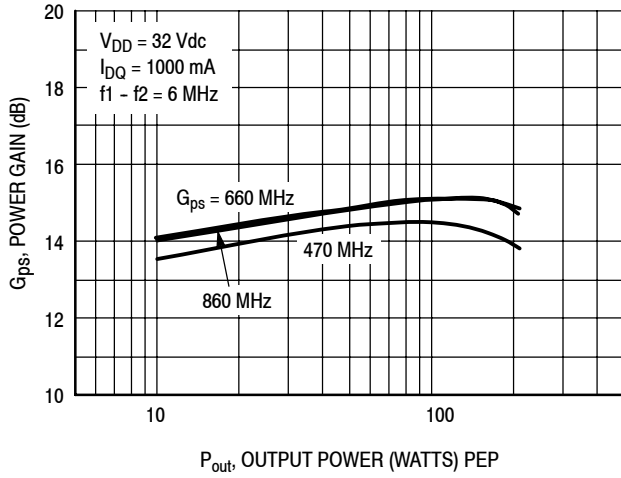

Figure 12. Power Gain versus Output Power

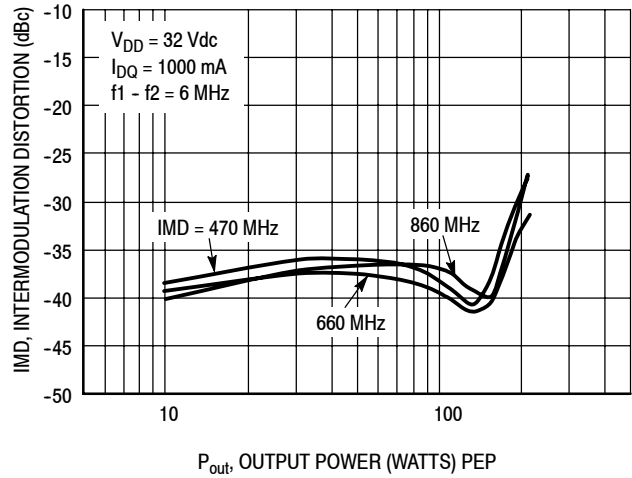

Figure 13. Intermodulation Distortion versus Output Power

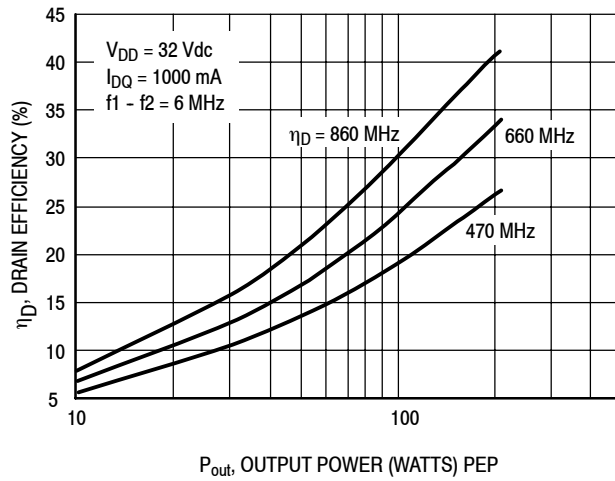
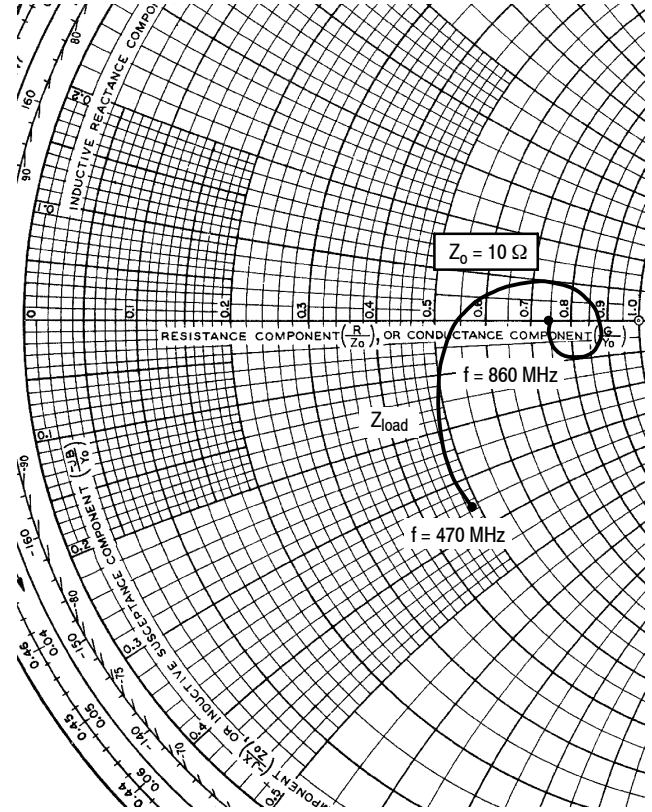
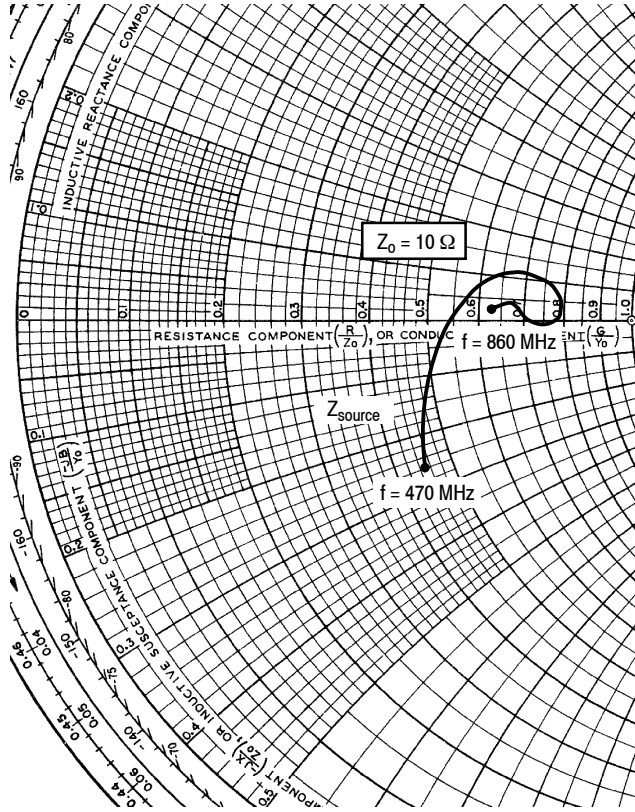

Figure 14. Drain Efficiency versus Output Power



$V_{DD} = 32\text{ V}$ ,  $I_{DQ} = 1000\text{ mA}$ ,  $P_{out} = 180\text{ W PEP}$

f MHz	$Z_{source}$ $\Omega$	$Z_{load}$ $\Omega$
470	$4.46 - j2.57$	$4.88 - j3.50$
560	$6.40 + j1.06$	$5.45 - j0.07$
660	$7.84 + j0.14$	$8.13 + j0.73$
760	$6.67 + j0.46$	$8.27 - j1.00$
860	$6.25 + j0.31$	$7.52 + j0.02$

$Z_{source}$  = Test circuit impedance as measured from gate to gate, balanced configuration.

$Z_{load}$  = Test circuit impedance as measured from drain to drain, balanced configuration.

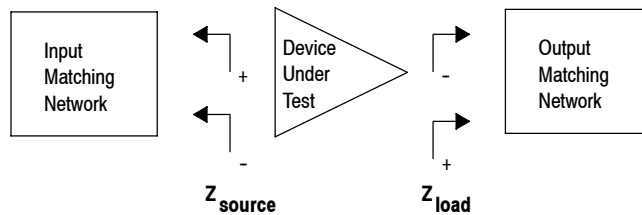

Figure 15. Broadband Series Equivalent Source and Load Impedance

ARCHIVE INFORMATION

ARCHIVE INFORMATION

ARCHIVE INFORMATION

ARCHIVE INFORMATION

# NOTES

ARCHIVE INFORMATION

ARCHIVE INFORMATION

### PACKAGE DIMENSIONS

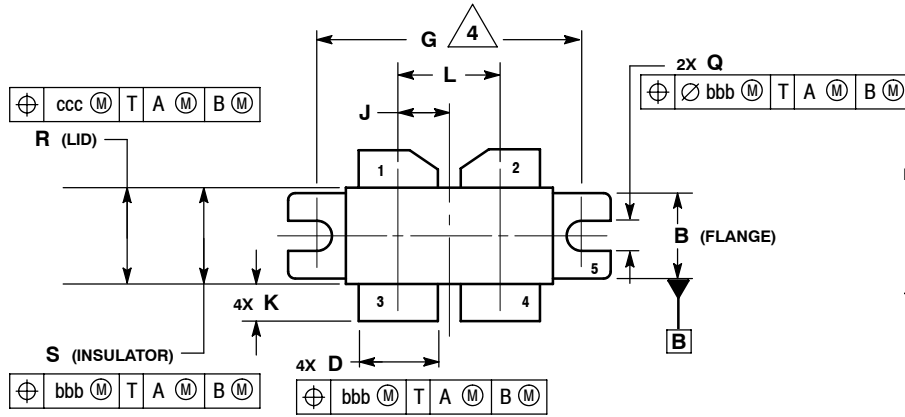

- NOTES:
1. CONTROLLING DIMENSION: INCH.
  2. INTERPRET DIMENSIONS AND TOLERANCES PER ASME Y14.5M-1994.
  3. DIMENSION H TO BE MEASURED 0.030 (0.762) AWAY FROM PACKAGE BODY.
  4. RECOMMENDED BOLT CENTER DIMENSION OF 1.140 (28.96) BASED ON 3M SCREW.

DIM	INCHES		MILLIMETERS	
	MIN	MAX	MIN	MAX
A	1.335	1.345	33.91	34.16
B	0.380	0.390	9.65	9.91
C	0.180	0.224	4.57	5.69
D	0.325	0.335	8.26	8.51
E	0.060	0.070	1.52	1.78
F	0.004	0.006	0.10	0.15
G	1.100 BSC		27.94 BSC	
H	0.097	0.107	2.46	2.72
J	0.2125 BSC		5.397 BSC	
K	0.135	0.165	3.43	4.19
L	0.425 BSC		10.8 BSC	
M	0.852	0.868	21.64	22.05
N	0.851	0.869	21.62	22.07
Q	0.118	0.138	3.00	3.30
R	0.395	0.405	10.03	10.29
S	0.394	0.406	10.01	10.31
bbb	0.010 REF		0.25 REF	
ccc	0.015 REF		0.38 REF	

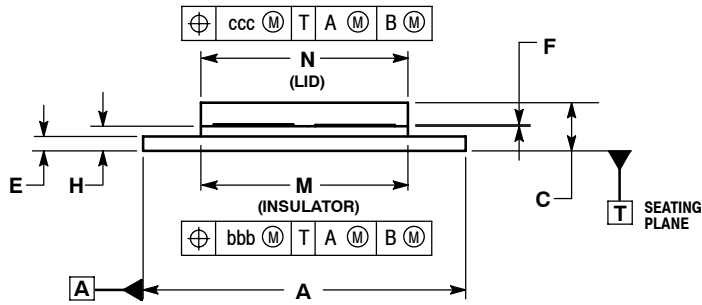

- STYLE 1:
- PIN 1. DRAIN
  - DRAIN
  - GATE
  - GATE
  - SOURCE

**CASE 375G-04  
ISSUE G  
NI-860C3**

ARCHIVE INFORMATION

ARCHIVE INFORMATION

**How to Reach Us:**

**Home Page:**  
www.freescale.com

**E-mail:**  
support@freescale.com

**USA/Europe or Locations Not Listed:**  
Freescale Semiconductor  
Technical Information Center, CH370  
1300 N. Alma School Road  
Chandler, Arizona 85224  
+1-800-521-6274 or +1-480-768-2130  
support@freescale.com

**Europe, Middle East, and Africa:**  
Freescale Halbleiter Deutschland GmbH  
Technical Information Center  
Schatzbogen 7  
81829 Muenchen, Germany  
+44 1296 380 456 (English)  
+46 8 52200080 (English)  
+49 89 92103 559 (German)  
+33 1 69 35 48 48 (French)  
support@freescale.com

**Japan:**  
Freescale Semiconductor Japan Ltd.  
Headquarters  
ARCO Tower 15F  
1-8-1, Shimo-Meguro, Meguro-ku,  
Tokyo 153-0064  
Japan  
0120 191014 or +81 3 5437 9125  
support.japan@freescale.com

**Asia/Pacific:**  
Freescale Semiconductor Hong Kong Ltd.  
Technical Information Center  
2 Dai King Street  
Tai Po Industrial Estate  
Tai Po, N.T., Hong Kong  
+800 2666 8080  
support.asia@freescale.com

**For Literature Requests Only:**  
Freescale Semiconductor Literature Distribution Center  
P.O. Box 5405  
Denver, Colorado 80217  
1-800-441-2447 or 303-675-2140  
Fax: 303-675-2150  
LDCForFreescaleSemiconductor@hibbertgroup.com

Information in this document is provided solely to enable system and software implementers to use Freescale Semiconductor products. There are no express or implied copyright licenses granted hereunder to design or fabricate any integrated circuits or integrated circuits based on the information in this document.

Freescale Semiconductor reserves the right to make changes without further notice to any products herein. Freescale Semiconductor makes no warranty, representation or guarantee regarding the suitability of its products for any particular purpose, nor does Freescale Semiconductor assume any liability arising out of the application or use of any product or circuit, and specifically disclaims any and all liability, including without limitation consequential or incidental damages. "Typical" parameters that may be provided in Freescale Semiconductor data sheets and/or specifications can and do vary in different applications and actual performance may vary over time. All operating parameters, including "Typicals", must be validated for each customer application by customer's technical experts. Freescale Semiconductor does not convey any license under its patent rights nor the rights of others. Freescale Semiconductor products are not designed, intended, or authorized for use as components in systems intended for surgical implant into the body, or other applications intended to support or sustain life, or for any other application in which the failure of the Freescale Semiconductor product could create a situation where personal injury or death may occur. Should Buyer purchase or use Freescale Semiconductor products for any such unintended or unauthorized application, Buyer shall indemnify and hold Freescale Semiconductor and its officers, employees, subsidiaries, affiliates, and distributors harmless against all claims, costs, damages, and expenses, and reasonable attorney fees arising out of, directly or indirectly, any claim of personal injury or death associated with such unintended or unauthorized use, even if such claim alleges that Freescale Semiconductor was negligent regarding the design or manufacture of the part.

Freescale™ and the Freescale logo are trademarks of Freescale Semiconductor, Inc. All other product or service names are the property of their respective owners.  
© Freescale Semiconductor, Inc. 2006, 2010. All rights reserved.

## Looking for pricing, stock, or lifecycle information?

Click below to explore more details on WIN SOURCE:

 [View MRF372R5 on WIN SOURCE](#)

 [NXP / Nexperia Information](#)

## Optimize Your Supply Chain with WIN SOURCE Solutions

-  Global Sourcing Solution
-  Obsolete Management
-  Cost Control Management
-  Shortage Management
-  Alternative Solution
-  Excess Inventory Management