



THE DATASHEET OF MRF553G



MRF553
MRF553G

* G Denotes RoHS Compliant, Pb Free Terminal Finish

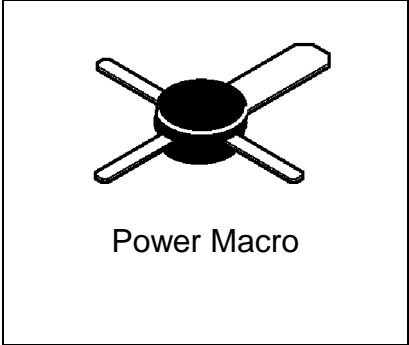

**RF & MICROWAVE DISCRETE
LOW POWER TRANSISTORS**

Features

- Specified @ 12.5 V, 175 MHz Characteristics
 - Output Power = 1.5 W
 - Minimum Gain = 11.5 dB
 - Efficiency 60% (Typ)
 - Cost Effective PowerMacro Package
 - Electroless Tin Plated Leads for Improved Solderability
-

DESCRIPTION: Designed primarily for wideband large signal stages in the VHF frequency range.

ABSOLUTE MAXIMUM RATINGS (T_{case} = 25°C)

Symbol	Parameter	Value	Unit
V _{CEO}	Collector-Emitter Voltage	16	Vdc
V _{CBO}	Collector-Base Voltage	36	Vdc
V _{EBO}	Emitter-Base Voltage	4.0	Vdc
I _C	Collector Current	500	mA

Thermal Data

P _D	Total Device Dissipation @ TC = 75°C	3.0	Watts mW/ °C
	Derate above 75°C	40	

**MRF553
MRF553G**

ELECTRICAL SPECIFICATIONS (T_{case} = 25°C)
**STATIC
(off)**

Symbol	Test Conditions	Value			Unit
		Min.	Typ.	Max.	
BVCEO	Collector-Emitter Breakdown Voltage (I _C =10 mAdc, I _B =0)	16	-	-	Vdc
BVCES	Collector-Emitter Sustaining Voltage (I _C = 5.0 mAdc, I _B = 0)	36	-	-	Vdc
BVCBO	Collector-Base Breakdown Voltage (I _E = 0, I _C = 5 mAdc)	36	-	-	Vdc
BVEBO	Emitter-Base Breakdown Voltage (I _E = 1 mAdc, I _C = 0)	4.0	-	-	Vdc
ICES	Collector Cutoff Current (V _{CE} = 15 Vdc, V _{BE} = 0 Vdc)	-	-	5	mA

(on)

HFE	DC Current Gain (I _C = 250 mAdc, V _{CE} = 5.0 Vdc) Both	30	-	200	-
-----	--------------------------------------------------------------------------------	----	---	-----	---

DYNAMIC

Symbol	Test Conditions	Value			Unit
		Min.	Typ.	Max.	
COB	Output Capacitance (V _{CB} = 10 Vdc, I _E = 0, f = 1.0 MHz)	-	12	20	pF

MRF553

MRF553G

FUNCTIONAL

Symbol	Test Conditions		Value			Unit
			Min.	Typ.	Max.	
G_{PE}	Power Gain	Test Circuit-Figure 1 Pout = 1.5 W, VCE =12.5Vdc f = 175 MHz	11.5	13	-	dB
η	Collector Efficiency	Test Circuit-Figure 1 Pout = 1.5 W, VCE =12.5Vdc f = 175 MHz	50	60	-	%
Ψ	Load Mismatch VSWR \geq 10:1 All Phase Angles	Test Circuit-Figure 1 Pout = 1.5 W, VCE =12.5Vdc f = 175 MHz	No Degradation in Output Power			-

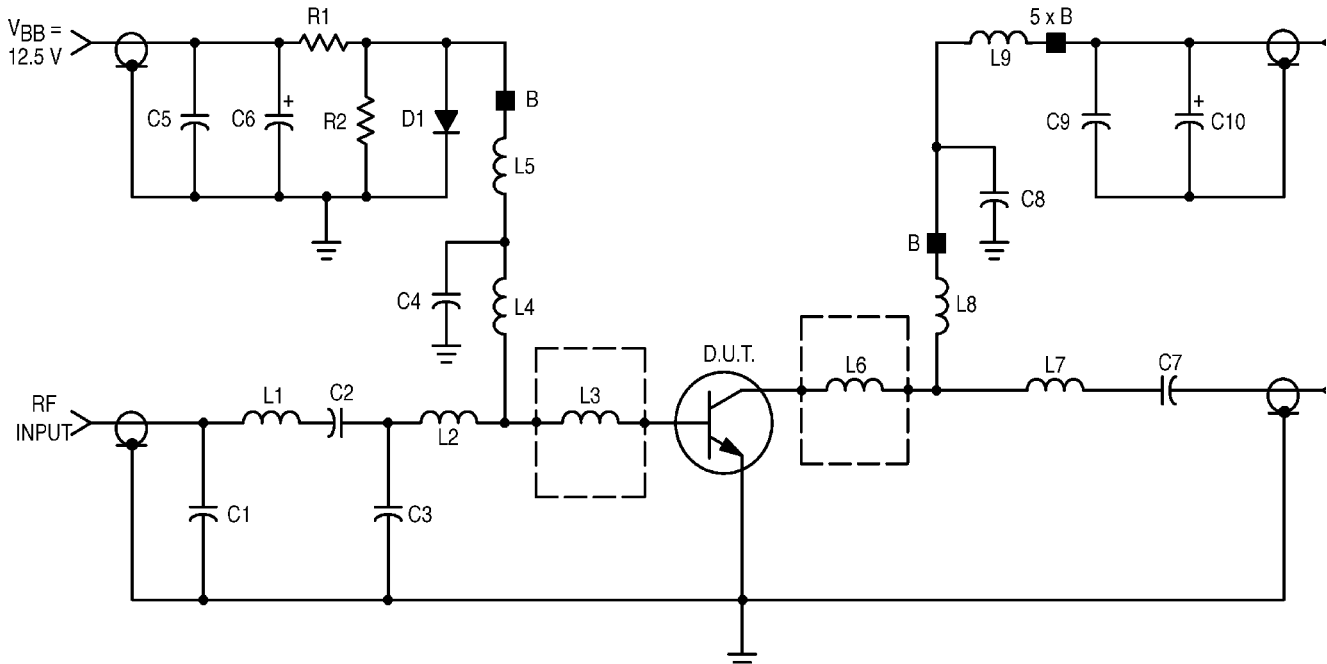
Figure 1. 140–175 MHz Broadband Circuit Schematic.

- | | |
|---------------------------------------------------------------------|---------------------------------------------------|
| C1 — 36 pF Mini Underwood | C2 — 47 pF Mini Underwood |
| C3 — 91 pF Mini Underwood | C4 — 68 pF Mini Underwood |
| C5, C9 — 1.0 μ F Erie Red Cap Capacitor | C6, C10 — 0.1 μ F, 35 V Tantalum |
| C7 — 470 pF Chip Capacitor | C8 — 2200 pF Chip Capacitor |
| R1 — 4.7 k Ω , 1/4 W | R2 — 100 Ω , 1/4 W |
| D1 — 1N4148 Diode | L1 — 3 Turns, #18 AWG, 0.210, ID, 3/16, Length |
| L2, L4, L7 — 0.62., #18 AWG Wire Bent into "V" | L3, L6 — 60 x 125 x 250 Mils Copper Pad on 27Mils |
| L5 — 12 μ H Molded Choke | L8 — 7 Turns, #18 AWG, 0.170, ID, 7/16, Length |
| L9 — 1.0., #18 AWG Wire with 5 Ferrite Beads | B — Ferrite Bead |
| Thick Alumina Substrate | |
| Board Material — Glass Teflon, $\epsilon_r = 2.56$, $t = 0.0625$, | |

MRF553

MRF553G

RF Low Power PA, LNA, and General Purpose Discrete Selector Guide

Package	Device	Type	GPE Freq (MHz)	Pout (watts)	GPE (dB)	Efficiency (%)	GPE VCC	BVCEO	IC max (mA)
SO-8	MRF4427, R2	NPN	175	0.15	18	60	12	20	400
TO-39	2N4427	NPN	175	1	10	50	12	20	400
POWER MACRO	MRF553	NPN	175	1.5	11.5	60	12.5	16	500
POWER MACRO	MRF553T	NPN	175	1.5	11.5	50	12.5	16	500
TO-39	MRF607	NPN	175	1.75	11.5	50	12.5	16	330
TO-39	2N6255	NPN	175	3	7.8	50	12.5	18	1000
TO-72	2N5179	NPN	200		20		6	12	50
MACRO X	MRF559	NPN	512	0.5	10	65	7.5	16	150
MACRO X	MRF559	NPN	512	0.5	13	60	12.5	16	150
TO-39	2N3866A	NPN	400	1	10	45	28	30	400
SO-8	MRF3866, R1, R2	NPN	400	1	10	45	28	30	400
POWER MACRO	MRF555	NPN	470	1.5	11	50	12.5	16	400
POWER MACRO	MRF555T	NPN	470	1.5	11	50	12.5	16	400
MACRO X	MRF559	NPN	870	0.5	6.5	70	7.5	16	150
MACRO X	MRF559	NPN	870	0.5	9.5	65	12.5	16	150
SO-8	MRF8372,R1,R2	NPN	870	0.75	8	55	12.5	16	200
POWER MACRO	MRF557	NPN	870	1.5	8	55	12.5	16	400
POWER MACRO	MRF557T	NPN	870	1.5	8	55	12.5	16	400

Package	Device	Type	Freq (MHz)	NF (dB)	NF IC (mA)	NF VCE	GN (dB)	Gu Max (dB)	Ftau (MHz)	Ccb(pF)	BVCEO	IC max (mA)
TO-39	2N5109	NPN	200	3	10	15		12	1200	3.5	20	400
TO-39	MRF5943C	NPN	200	3.4	30	15		11.4	1000		30	400
SO-8	MRF5943, R1, R2	NPN	200	3.4	30	15		15	1300		30	400
TO-72	2N5179	NPN	200	4.5	1.5	6		17	900	1	12	50
TO-72	2N2857	NPN	300	5.5	50	6		13	1600	1	15	40
TO-39	MRF517	NPN	300	7.5	50	15		5.5	4600	3	25	150
TO-72	MRF904	NPN	450	1.5	5	6		11	4000	1	15	30
TO-72	2N6304	NPN	450	5	2	5		14	1400	1	15	50
MACRO T	BFR91	NPN	500	1.9	2	5	11	16.5	5000	1	12	35
MACRO T	BFR96	NPN	500	2	10	10		14.5	500	2.6	15	100
SO-8	MRF5812, R1, R2	NPN	500	2	50	10	15.5	17.8	5000		15	200
MACRO X	MRF581A	NPN	500	2	50	10	14	15	5000		15	200
Macro	BFR90	NPN	500	2.4	2	10	15	18	5000	1	15	30
TO-72	BFY90	NPN	500	2.5	2	5		20	1300		15	50
TO-72	MRF914	NPN	500	2.5	5	10		15	4500		12	40
MACRO X	MRF581	NPN	500	2.5	50	10	15	17.8	5000		16	200
TO-39	MRF586	NPN	500	3	90	15	11	14.5	4500	2.2	17	200
MACRO X	MRF951	NPN	1000	1.3	5	6	14	17	8000	0.45	10	100
MACRO X	MRF571	NPN	1000	1.5	10	6	10		8000	1	10	70
MACRO T	BFR91	NPN	1000	2.5	2	5	8	11	5000	1	12	35
MACRO T	BFR90	NPN	1000	3	2	10	10	12.5	5000	1	15	30
TO-39	MRF545	PNP						14	1400	2	70	400
TO-39	MRF544	NPN						13.5	1500		70	400

RF (Low Power PA / General Purpose) Selection Guide

RF (LNA / General Purpose) Selection Guide

Low Cost RF Plastic Package Options

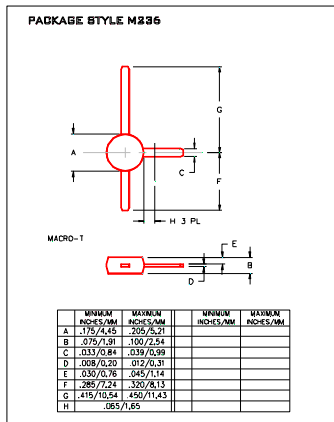

Macro T

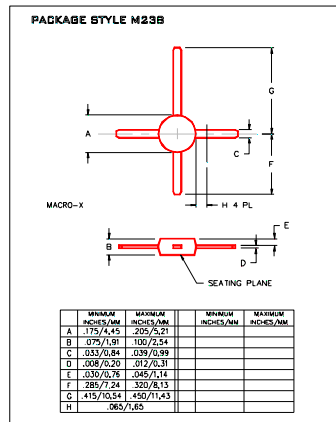

Macro X

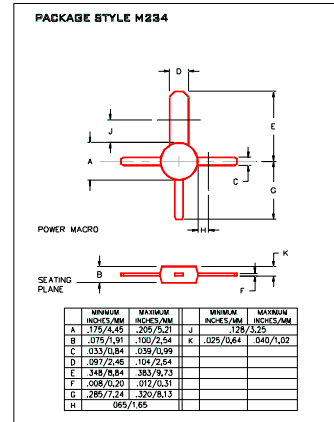

Power Macro

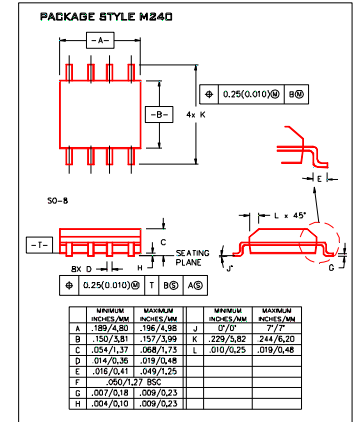

SO-8

**MRF553
MRF553G**

PACKAGE STYLE M234

- PIN 1. COLLECTOR
- 2. EMITTER
- 3. BASE
- 4. EMITTER

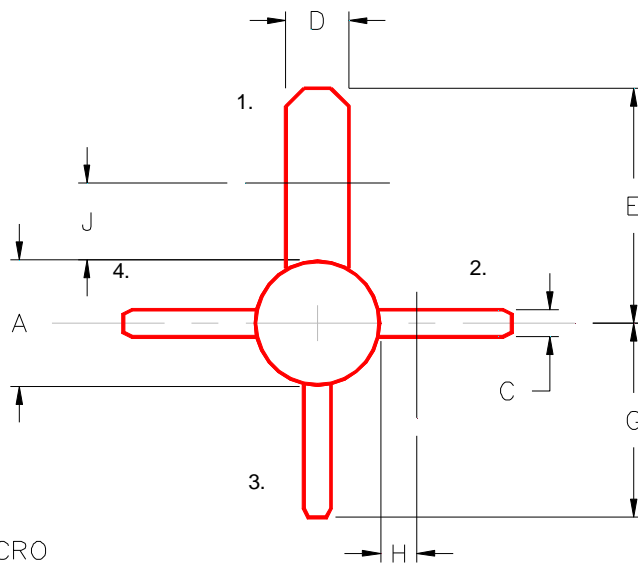

POWER MACRO

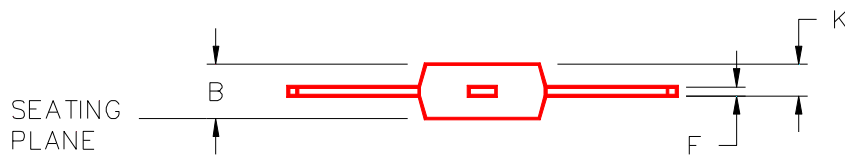

	MINIMUM INCHES/MM	MAXIMUM INCHES/MM		MINIMUM INCHES/MM	MAXIMUM INCHES/MM
A	.175/4,45	.205/5,21	J	.128/3,25	
B	.075/1,91	.100/2,54	K	.025/0,64	.040/1,02
C	.033/0,84	.039/0,99			
D	.097/2,46	.104/2,64			
E	.348/8,84	.383/9,73			
F	.008/0,20	.012/0,31			
G	.285/7,24	.320/8,13			
H	.065/1,65				

Looking for pricing, stock, or lifecycle information?

Click below to explore more details on WIN SOURCE:

 [View MRF553G on WIN SOURCE](#)

 [Microsemi Corporation](#) Information

Optimize Your Supply Chain with WIN SOURCE Solutions

-  Global Sourcing Solution
-  Obsolete Management
-  Cost Control Management
-  Shortage Management
-  Alternative Solution
-  Excess Inventory Management