



**THE DATASHEET OF  
MRF6S20010G NR1**



# RF Power Field Effect Transistors

## N-Channel Enhancement-Mode Lateral MOSFETs

Designed for Class A or Class AB general purpose applications with frequencies from 1600 to 2200 MHz. Suitable for analog and digital modulation and multipurpose amplifier applications.

- Typical Two-Tone Performance @ 2170 MHz:  $V_{DD} = 28$  Volts,  $I_{DQ} = 130$  mA,  $P_{out} = 10$  Watts PEP  
Power Gain — 15.5 dB  
Drain Efficiency — 36%  
IMD — -34 dBc
- Typical 2-Carrier W-CDMA Performance:  $V_{DD} = 28$  Volts,  $I_{DQ} = 130$  mA,  $P_{out} = 1$  Watt Avg., Full Frequency Band (2130-2170 MHz), Channel Bandwidth = 3.84 MHz. PAR = 8.5 dB @ 0.01% Probability  
Power Gain — 15.5 dB  
Drain Efficiency — 15%  
IM3 @ 10 MHz Offset — -47 dBc in 3.84 MHz Channel Bandwidth  
ACPR @ 5 MHz Offset — -49 dBc in 3.84 MHz Channel Bandwidth
- Typical Single-Carrier N-CDMA Performance:  $V_{DD} = 28$  Volts,  $I_{DQ} = 130$  mA,  $P_{out} = 1$  Watt Avg., Full Frequency Band (1930-1990 MHz), IS-95 (Pilot, Sync, Paging, Traffic Codes 8 through 13), Channel Bandwidth = 1.2288 MHz. PAR = 9.8 dB @ 0.01% Probability on CCDF.  
Power Gain — 15.5 dB  
Drain Efficiency — 16%  
ACPR @ 885 kHz Offset = -60 dBc in 30 kHz Bandwidth
- Typical GSM EDGE Performance:  $V_{DD} = 28$  Volts,  $I_{DQ} = 130$  mA,  $P_{out} = 4$  Watts Avg., Full Frequency Band (1805-1880 MHz)  
Power Gain — 16 dB  
Drain Efficiency — 33%  
EVM — 1.3% rms
- Capable of Handling 5:1 VSWR, @ 28 Vdc, 2000 MHz, 10 Watts CW Output Power

### Features

- Characterized with Series Equivalent Large-Signal Impedance Parameters
- Internally Matched for Ease of Use
- Qualified Up to a Maximum of 32  $V_{DD}$  Operation
- Integrated ESD Protection
- 225°C Capable Plastic Package
- In Tape and Reel. R1 Suffix = 500 Units, 24 mm Tape Width, 13-inch Reel.

**Table 1. Maximum Ratings**

Rating	Symbol	Value	Unit
Drain-Source Voltage	$V_{DSS}$	-0.5, +68	Vdc
Gate-Source Voltage	$V_{GS}$	-0.5, +12	Vdc
Storage Temperature Range	$T_{stg}$	-65 to +150	°C
Case Operating Temperature	$T_C$	150	°C
Operating Junction Temperature (1,2)	$T_J$	225	°C

1. Continuous use at maximum temperature will affect MTTF.
2. MTTF calculator available at <http://www.freescale.com/rtf>. Select Software & Tools/Development Tools/Calculators to access MTTF calculators by product.

**MRF6S20010NR1**  
**MRF6S20010GNR1**

**1600-2200 MHz, 10 W, 28 V**  
**GSM, GSM EDGE**  
**SINGLE N-CDMA**  
**2 x W-CDMA**  
**LATERAL N-CHANNEL**  
**RF POWER MOSFETs**

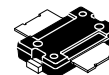

**TO-270-2**  
**PLASTIC**  
**MRF6S20010NR1**

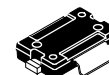

**TO-270G-2**  
**PLASTIC**  
**MRF6S20010GNR1**

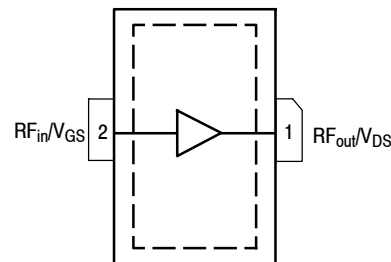

(Top View)

Note: The backside of the package is the source terminal for the transistor.

**Figure 1. Pin Connections**

**Table 2. Thermal Characteristics**

Characteristic	Symbol	Value (1,2)	Unit
Thermal Resistance, Junction to Case Case Temperature 78°C, 1 W CW Case Temperature 79°C, 10 W PEP, Two-Tone Test	$R_{\theta JC}$	2.3 2.9	°C/W

**Table 3. ESD Protection Characteristics**

Test Methodology	Class
Human Body Model (per JESD22-A114)	1A
Machine Model (per EIA/JESD22-A115)	A
Charge Device Model (per JESD22-C101)	IV

**Table 4. Moisture Sensitivity Level**

Test Methodology	Rating	Package Peak Temperature	Unit
Per JESD22-A113, IPC/JEDEC J-STD-020	3	260	°C

**Table 5. Electrical Characteristics** ( $T_A = 25^\circ\text{C}$  unless otherwise noted)

Characteristic	Symbol	Min	Typ	Max	Unit
----------------	--------	-----	-----	-----	------

**Off Characteristics**

Zero Gate Voltage Drain Leakage Current ( $V_{DS} = 68\text{ Vdc}$ , $V_{GS} = 0\text{ Vdc}$ )	$I_{DSS}$	—	—	10	$\mu\text{Adc}$
Zero Gate Voltage Drain Leakage Current ( $V_{DS} = 28\text{ Vdc}$ , $V_{GS} = 0\text{ Vdc}$ )	$I_{DSS}$	—	—	1	$\mu\text{Adc}$
Gate-Source Leakage Current ( $V_{GS} = 5\text{ Vdc}$ , $V_{DS} = 0\text{ Vdc}$ )	$I_{GSS}$	—	—	500	$\mu\text{Adc}$

**On Characteristics**

Gate Threshold Voltage ( $V_{DS} = 10\text{ Vdc}$ , $I_D = 40\ \mu\text{Adc}$ )	$V_{GS(th)}$	1.5	2.2	3.5	Vdc
Gate Quiescent Voltage ( $V_{DD} = 28\text{ Vdc}$ , $I_D = 130\text{ mAdc}$ , Measured in Functional Test)	$V_{GS(Q)}$	2	2.8	4	Vdc
Drain-Source On-Voltage ( $V_{GS} = 10\text{ Vdc}$ , $I_D = 0.4\text{ Adc}$ )	$V_{DS(on)}$	—	0.33	0.4	Vdc

**Dynamic Characteristics (3)**

Output Capacitance ( $V_{DS} = 28\text{ Vdc} \pm 30\text{ mV(rms)ac}$ @ 1 MHz, $V_{GS} = 0\text{ Vdc}$ )	$C_{OSS}$	—	20	—	pF
Reverse Transfer Capacitance ( $V_{DS} = 28\text{ Vdc} \pm 30\text{ mV(rms)ac}$ @ 1 MHz, $V_{GS} = 0\text{ Vdc}$ )	$C_{RSS}$	—	11.6	—	pF
Input Capacitance ( $V_{DS} = 28\text{ Vdc}$ , $V_{GS} = 0\text{ Vdc} \pm 30\text{ mV(rms)ac}$ @ 1 MHz)	$C_{ISS}$	—	120	—	pF

**Functional Tests (4)** (In Freescale Test Fixture, 50 ohm system)  $V_{DD} = 28\text{ Vdc}$ ,  $I_{DQ} = 130\text{ mA}$ ,  $P_{out} = 10\text{ W PEP}$ ,  $f_1 = 2170\text{ MHz}$ ,  $f_2 = 2170.1\text{ MHz}$ , Two-Tone Test

Power Gain	$G_{ps}$	14	15.5	17	dB
Drain Efficiency	$\eta_D$	33	36	—	%
Intermodulation Distortion	IMD	—	-34	-28	dBc
Input Return Loss	IRL	—	-15	-9	dB

1. MTTF calculator available at <http://www.freescale.com/rf>. Select Software & Tools/Development Tools/Calculators to access MTTF calculators by product.
2. Refer to AN1955, *Thermal Measurement Methodology of RF Power Amplifiers*. Go to <http://www.freescale.com/rf>. Select Documentation/Application Notes - AN1955.
3. Part internally matched on input.
4. Measurements made with device in straight lead configuration before any lead forming operation is applied. Lead forming is used for gull wing (GN) parts.

(continued)

**Table 5. Electrical Characteristics** ( $T_A = 25^\circ\text{C}$  unless otherwise noted) (continued)

Characteristic	Symbol	Min	Typ	Max	Unit
----------------	--------	-----	-----	-----	------

**Typical 2-Carrier W-CDMA Performances** (In Freescale CDMA Test Fixture, 50 ohm system)  $V_{DD} = 28\text{ Vdc}$ ,  $I_{DQ} = 130\text{ mA}$ ,  $P_{out} = 1\text{ W Avg.}$ ,  $f_1 = 2112.5\text{ MHz}$ ,  $f_2 = 2122.5\text{ MHz}$  and  $f_1 = 2157.5\text{ MHz}$ ,  $f_2 = 2167.5\text{ MHz}$ , 2-Carrier W-CDMA, 3.84 MHz Channel Bandwidth Carriers. ACPR measured in 3.84 MHz Channel Bandwidth @  $\pm 5\text{ MHz}$  Offset. IM3 measured in 3.84 MHz Bandwidth @  $\pm 10\text{ MHz}$  Offset. PAR = 8.5 dB @ 0.01% Probability on CCDF.

Power Gain	$G_{ps}$	—	15.5	—	dB
Drain Efficiency	$\eta_D$	—	15	—	%
Gain Flatness in 30 MHz Bandwidth @ $P_{out} = 1\text{ W CW}$	$G_F$	—	0.3	—	dB
Intermodulation Distortion	IM3	—	-47	—	dBc
Adjacent Channel Power Ratio	ACPR	—	-49	—	dBc

**Typical N-CDMA Performances** (In Freescale Test Fixture, 50 ohm system)  $V_{DD} = 28\text{ Vdc}$ ,  $I_{DQ} = 130\text{ mA}$ ,  $P_{out} = 1\text{ W Avg.}$ , 1930 MHz < Frequency < 1990 MHz, Single-Carrier N-CDMA, 1.2288 MHz Channel Bandwidth Carrier. ACPR measured in 30 kHz Channel Bandwidth @  $\pm 885\text{ kHz}$  Offset. PAR = 9.8 dB @ 0.01% Probability on CCDF

Power Gain	$G_{ps}$	—	15.5	—	dB
Drain Efficiency	$\eta_D$	—	16	—	%
Gain Flatness in 30 MHz Bandwidth @ $P_{out} = 1\text{ W CW}$	$G_F$	—	0.3	—	dB
Adjacent Channel Power Ratio	ACPR	—	-60	—	dBc

**Typical GSM EDGE Performances** (In Freescale GSM EDGE Test Fixture, 50 ohm system)  $V_{DD} = 28\text{ Vdc}$ ,  $I_{DQ} = 130\text{ mA}$ ,  $P_{out} = 4\text{ W Avg.}$ , 1805-1880 MHz, EDGE Modulation

Power Gain	$G_{ps}$	—	16	—	dB
Drain Efficiency	$\eta_D$	—	33	—	%
Gain Flatness in 30 MHz Bandwidth @ $P_{out} = 4\text{ W CW}$	$G_F$	—	0.3	—	dB
Error Vector Magnitude	EVM	—	1.3	—	% rms
Spectral Regrowth at 400 kHz Offset	SR1	—	-60	—	dBc
Spectral Regrowth at 600 kHz Offset	SR2	—	-70	—	dBc

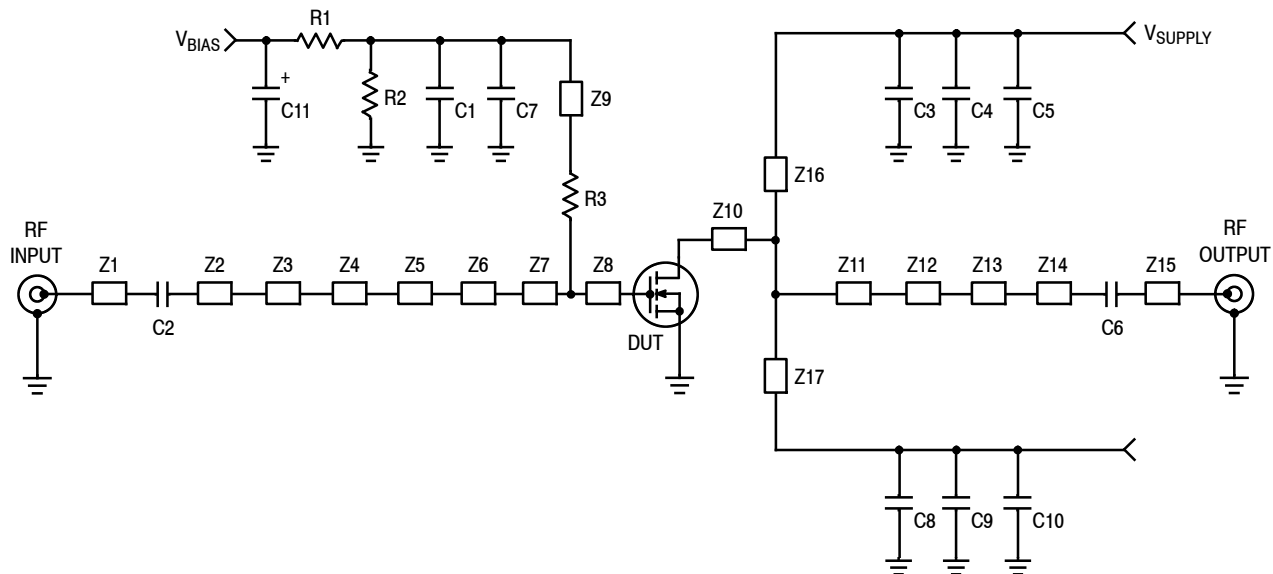

Z1, Z15	0.066" x 0.480" Microstrip	Z10	0.930" x 0.350" Microstrip
Z2	0.066" x 0.765" Microstrip	Z11	0.930" x 0.400" Microstrip
Z3, Z5	0.066" x 0.340" x 0.050" Taper	Z12	0.050" x 0.105" Microstrip
Z4	0.340" x 0.295" Microstrip	Z13	0.405" x 0.242" Microstrip
Z6	0.020" x 0.060" Microstrip	Z14	0.066" x 0.740" Microstrip
Z7	0.0905" x 0.280" Microstrip	Z16, Z17	0.050" x 1.250" Microstrip
Z8	0.0905" x 0.330" Microstrip	PCB	Taconic RF-35, 0.030", $\epsilon_r = 3.5$
Z9	0.050" x 0.980" Microstrip		

Figure 2. MRF6S20010NR1 Test Circuit Schematic — 2110-2170 MHz

Table 6. MRF6S20010NR1 Test Circuit Component Designations and Values — 2110-2170 MHz

Part	Description	Part Number	Manufacturer
C1	100 nF Chip Capacitor	CDR33BX104AKYS	Kemet
C2, C6	4.7 pF Chip Capacitors	ATC100B4R7CT500XT	ATC
C3, C7, C8	9.1 pF Chip Capacitors	ATC100B9R1CT500XT	ATC
C4, C5, C9, C10	10 $\mu$ F, 50 V Chip Capacitors	GRM55DR61H106KA88B	Murata
C11	10 $\mu$ F, 35 V Tantalum Chip Capacitor	T490D106K035AT	Kemet
R1	1 k $\Omega$ , 1/4 W Chip Resistor	CRCW12061001FKEA	Vishay
R2	10 k $\Omega$ , 1/4 W Chip Resistor	CRCW12061002FKEA	Vishay
R3	10 $\Omega$ , 1/4 W Chip Resistor	CRCW120610R0FKEA	Vishay

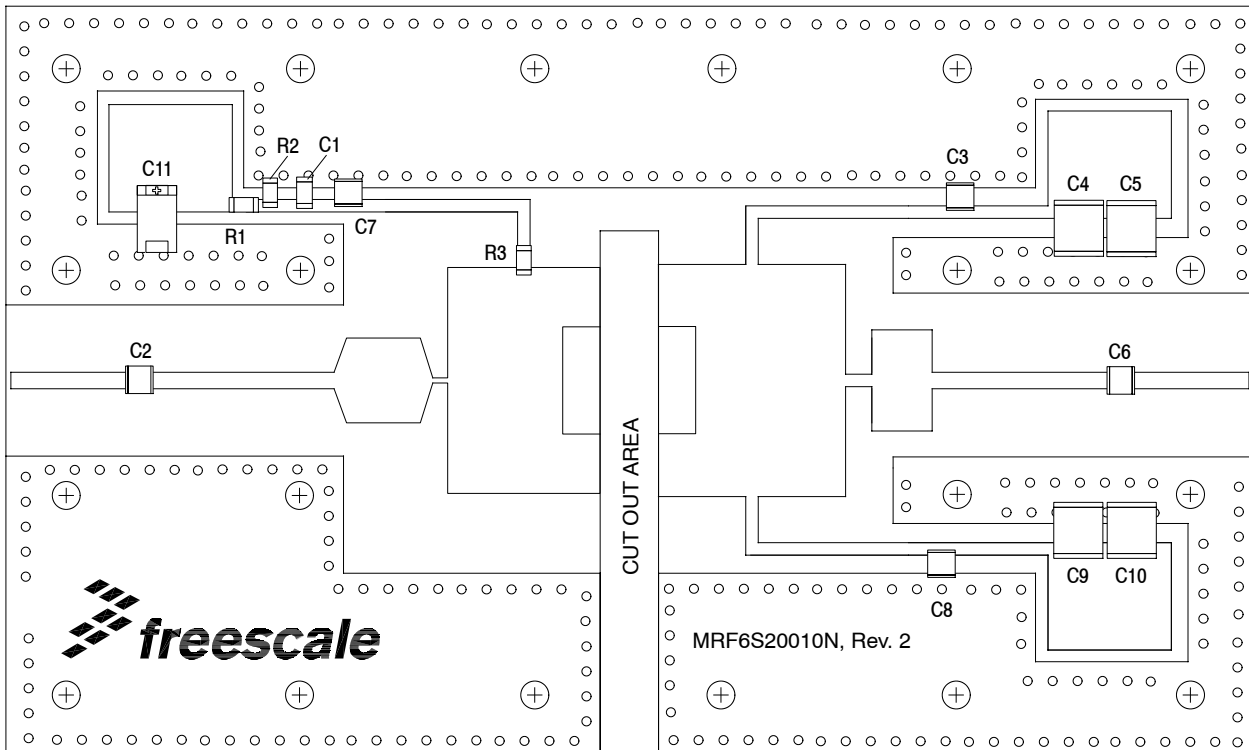
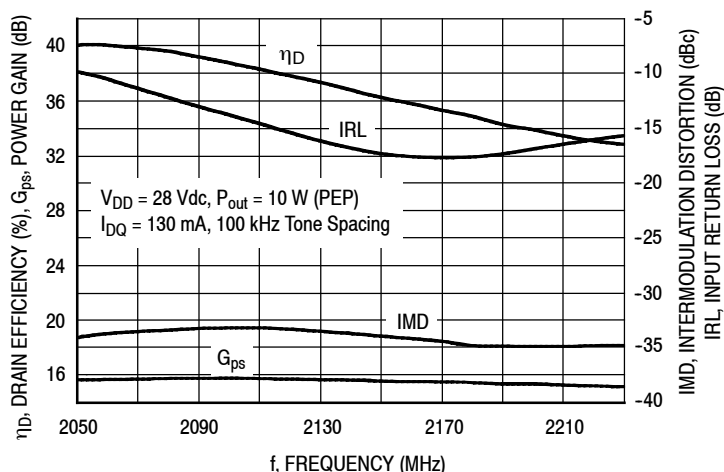
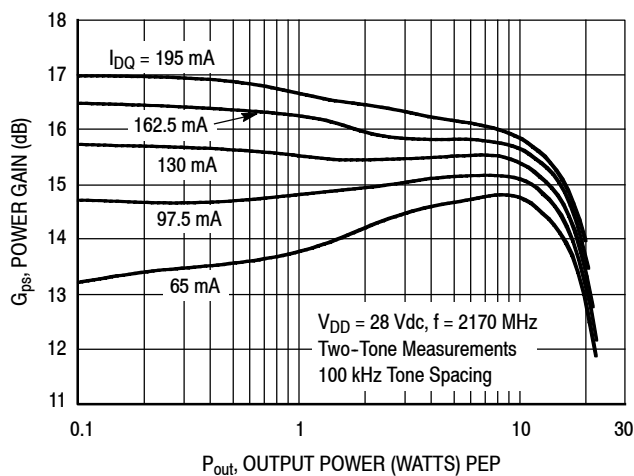

Figure 3. MRF6S20010NR1 Test Circuit Component Layout — 2110-2170 MHz

### TYPICAL CHARACTERISTICS — 2110-2170 MHz



**Figure 4. Two-Tone Wideband Performance @ P<sub>out</sub> = 10 Watts (PEP)**



**Figure 5. Two-Tone Power Gain versus Output Power**

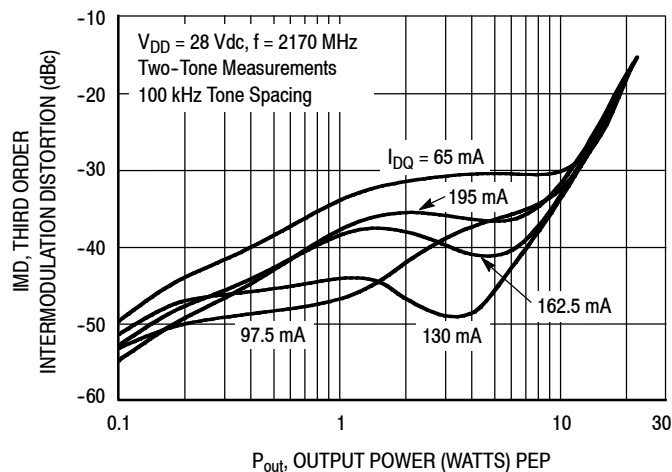

**Figure 6. Third Order Intermodulation Distortion versus Output Power**

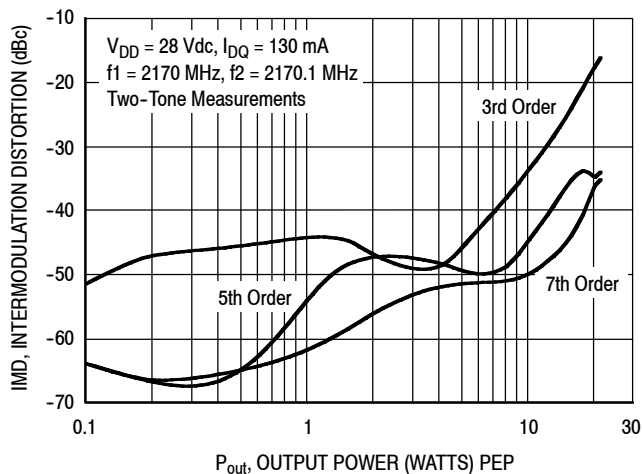

**Figure 7. Intermodulation Distortion Products versus Output Power**

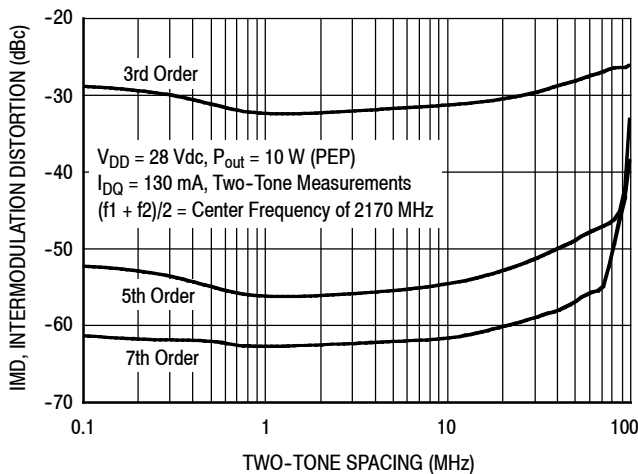

**Figure 8. Intermodulation Distortion Products versus Tone Spacing**

TYPICAL CHARACTERISTICS — 2110-2170 MHz

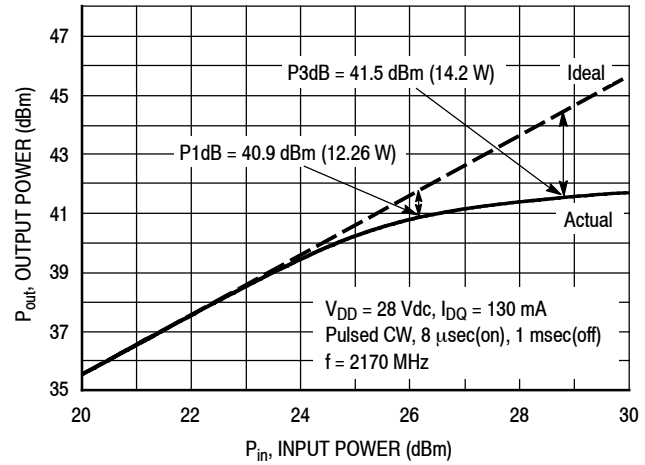

Figure 9. Pulsed CW Output Power versus Input Power

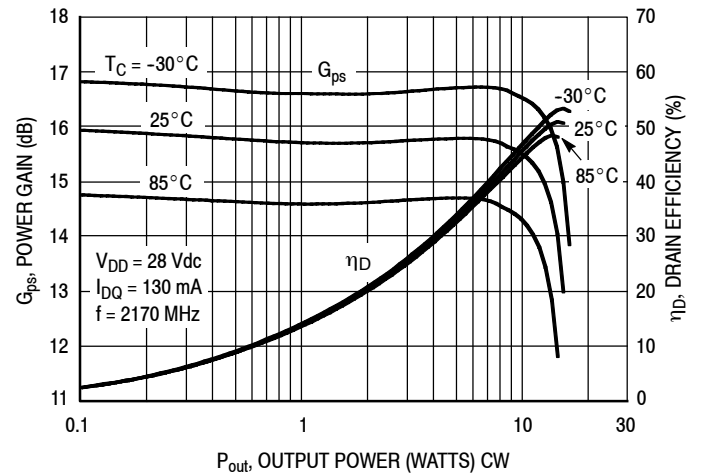

Figure 10. Power Gain and Drain Efficiency versus CW Output Power

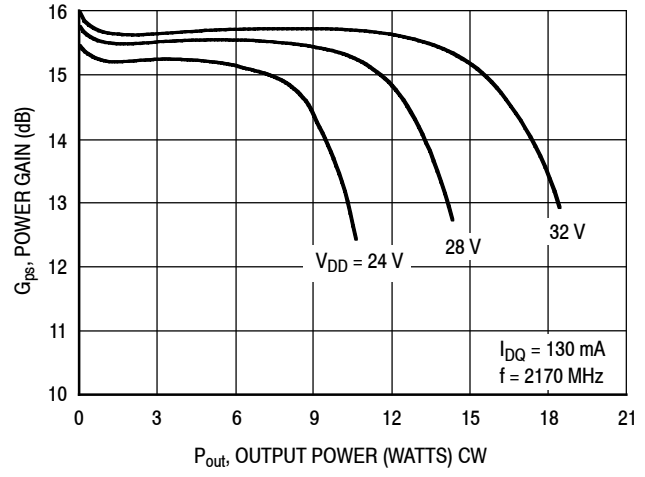

Figure 11. Power Gain versus Output Power

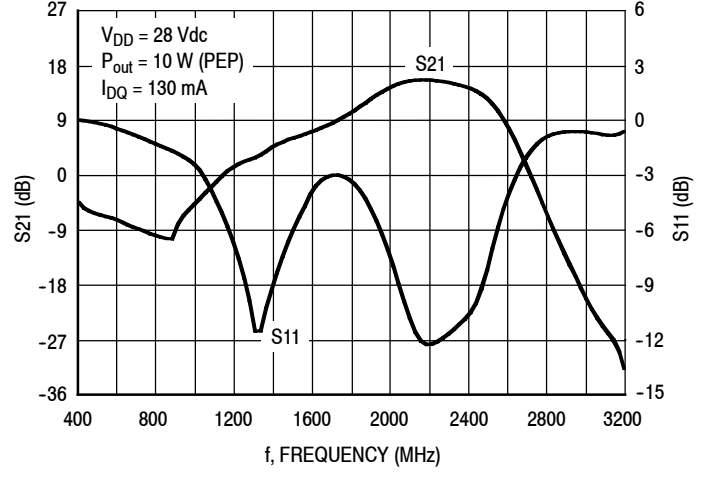
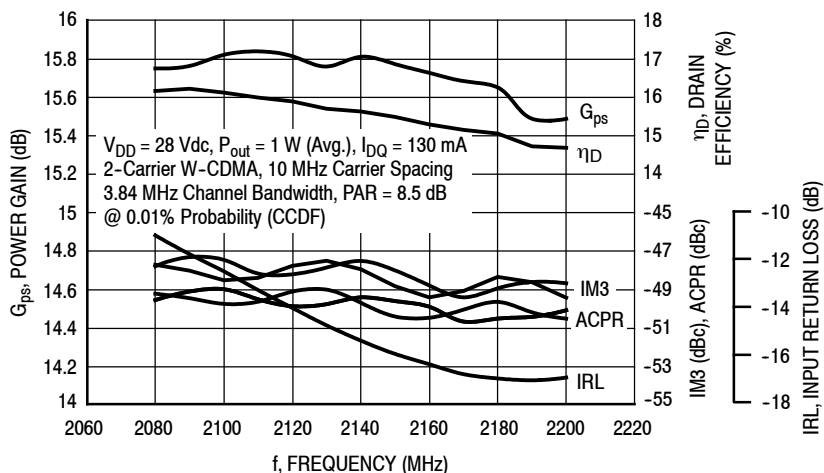
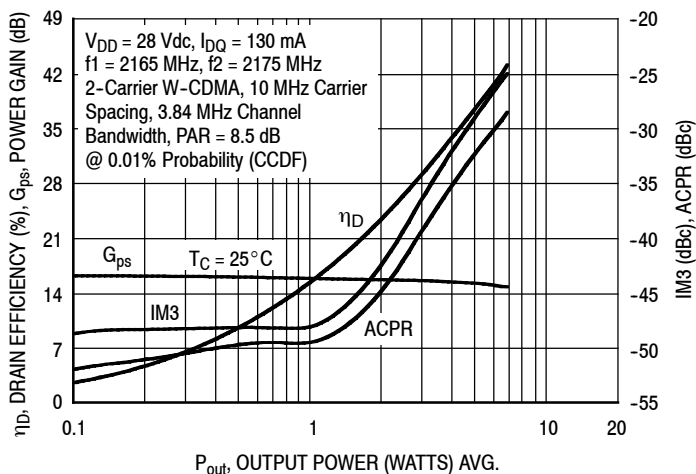

Figure 12. Broadband Frequency Response

### W-CDMA TYPICAL CHARACTERISTICS — 2110-2170 MHz

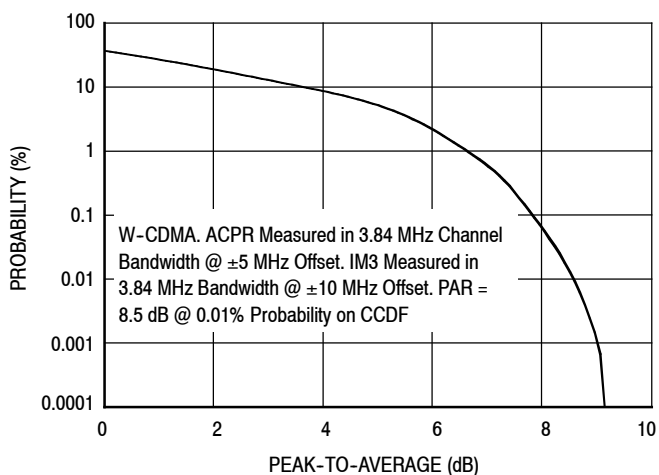

**Figure 13. 2-Carrier W-CDMA Broadband Performance @ P<sub>out</sub> = 1 Watt Avg.**

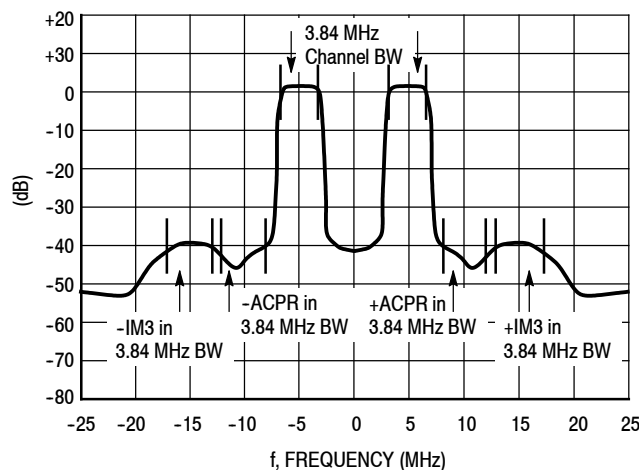

**Figure 14. 2-Carrier W-CDMA ACPR, IM3, Power Gain and Drain Efficiency versus Output Power**

### W-CDMA TEST SIGNAL

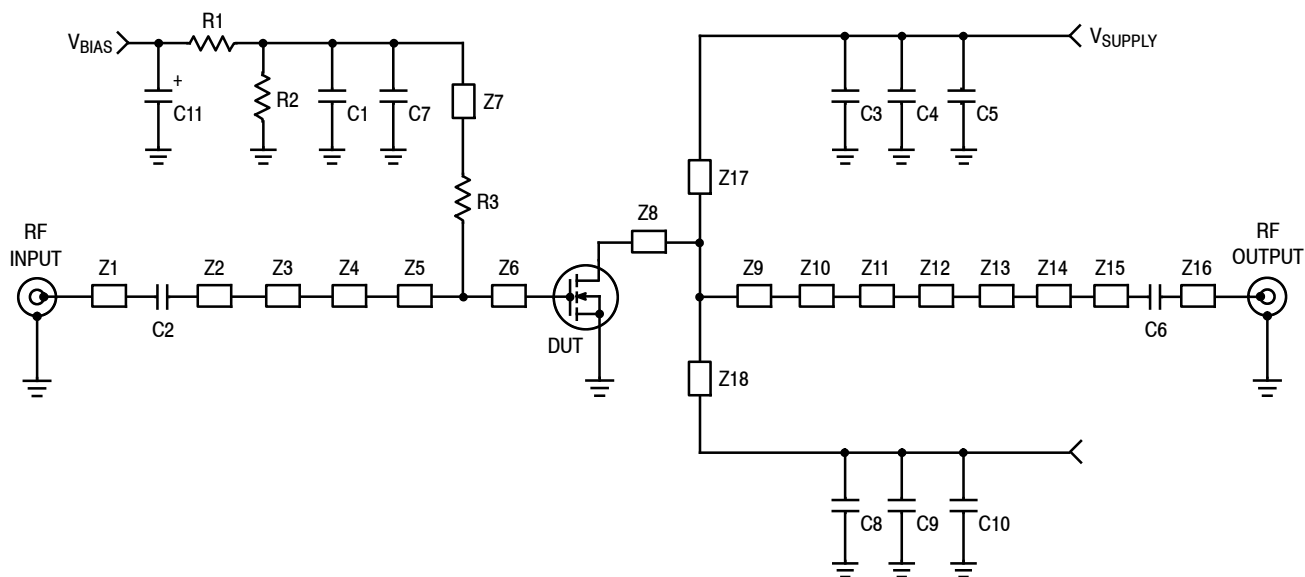

**Figure 15. CCDF W-CDMA 3GPP, Test Model 1, 64 DPCH, 67% Clipping, Single-Carrier Test Signal**



**Figure 16. 2-Carrier W-CDMA Spectrum**

## N-CDMA TYPICAL CHARACTERISTICS — 1930-1990 MHz



Z1	0.066" x 0.480" Microstrip	Z11	0.244" x 0.423" Microstrip
Z2	0.066" x 0.728" Microstrip	Z12	0.244" x 0.066" x 0.089" Taper
Z3	0.354" x 0.512" Microstrip	Z13	0.066" x 0.182" Microstrip
Z4	0.066" x 0.079" Microstrip	Z14	0.066" x 0.263" Microstrip
Z5, Z6	0.591" x 0.335" Microstrip	Z15	0.236" x 0.118" Microstrip
Z7	0.050" x 0.980" Microstrip	Z16	0.066" x 0.099" Microstrip
Z8	1.142" x 0.350" Microstrip	Z17, Z18	0.050" x 1.250" Microstrip
Z9	1.142" x 0.516" Microstrip	PCB	Taconic RF-35, 0.030", $\epsilon_r = 3.5$
Z10	0.433" x 0.276" Microstrip		

**Figure 17. MRF6S20010NR1 Test Circuit Schematic — 1930-1990 MHz**

**Table 7. MRF6S20010NR1 Test Circuit Component Designations and Values — 1930-1990 MHz**

Part	Description	Part Number	Manufacturer
C1	100 nF Chip Capacitor	12065C104KAT	AVX
C2, C6	4.7 pF Chip Capacitors	ATC100B4R7BT500XT	ATC
C3, C7, C8	9.1 pF Chip Capacitors	ATC100B9R1BT500XT	ATC
C4, C5, C9, C10	10 $\mu$ F Chip Capacitors	C5750X5R1H106MT	TDK
C11	10 $\mu$ F, 35 V Tantalum Chip Capacitor	TAJD106K035R	AVX
R1, R2	10 k $\Omega$ , 1/4 W Chip Resistors	CRCW12061002FKEA	Vishay
R3	10 $\Omega$ , 1/4 W Chip Resistor	CRCW120610R0FKEA	Vishay

N-CDMA TYPICAL CHARACTERISTICS — 1930-1990 MHz

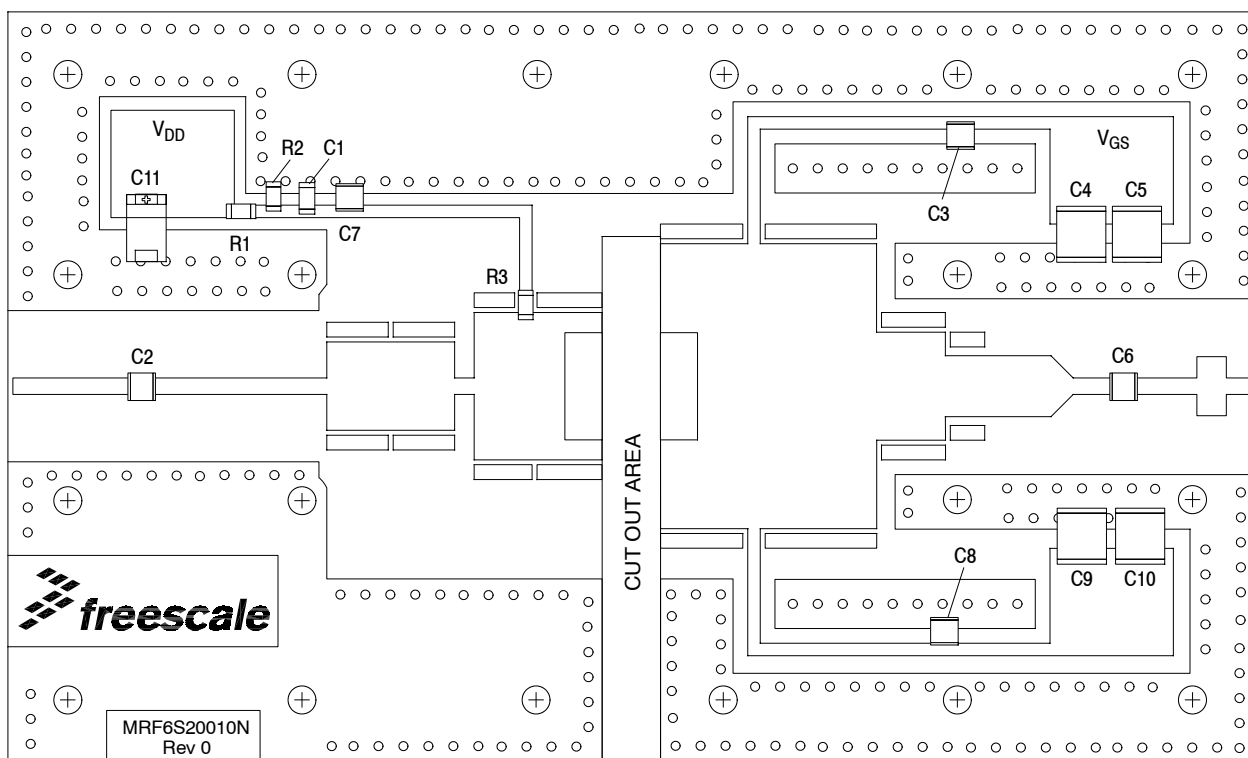
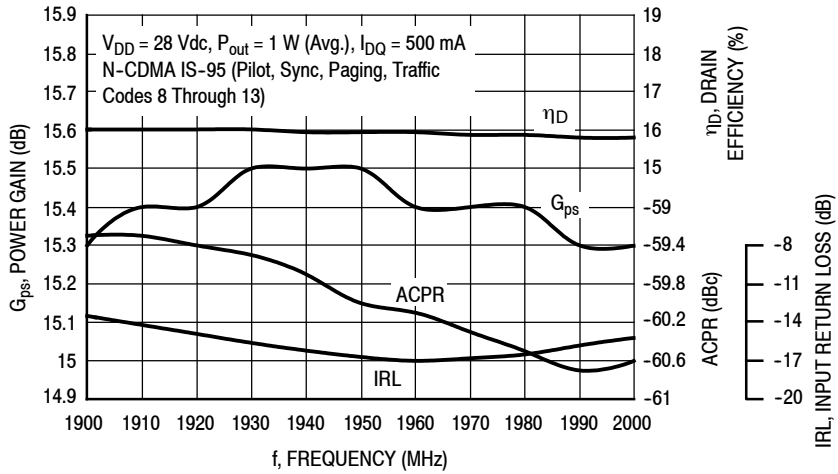
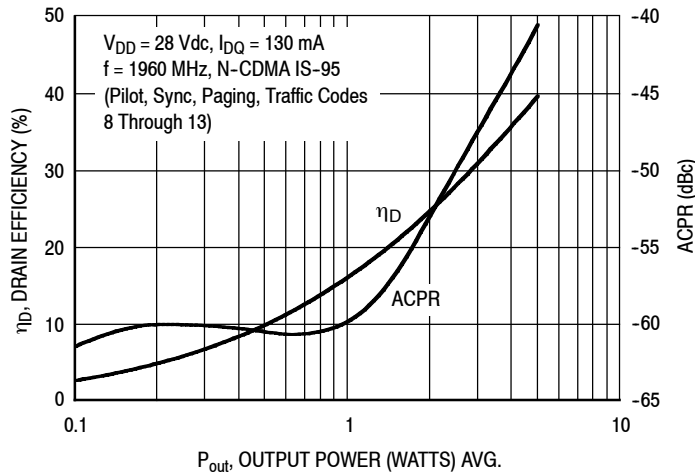

Figure 18. MRF6S20010NR1 Test Circuit Component Layout — 1930-1990 MHz

### N-CDMA TYPICAL CHARACTERISTICS — 1930-1990 MHz

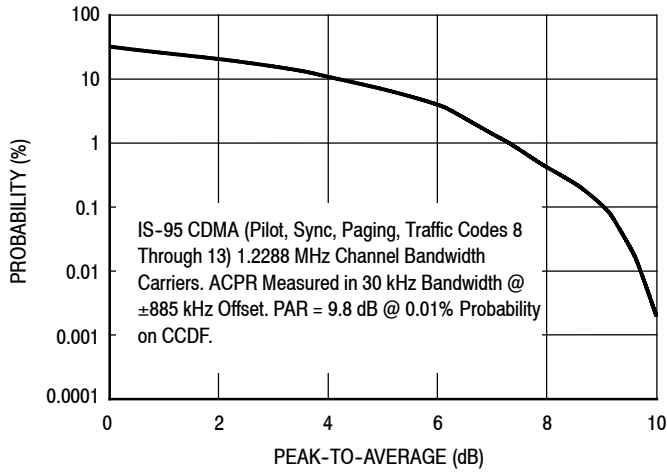

**Figure 19. Single-Carrier N-CDMA Broadband Performance @  $P_{out} = 1 \text{ Watt Avg.}$**

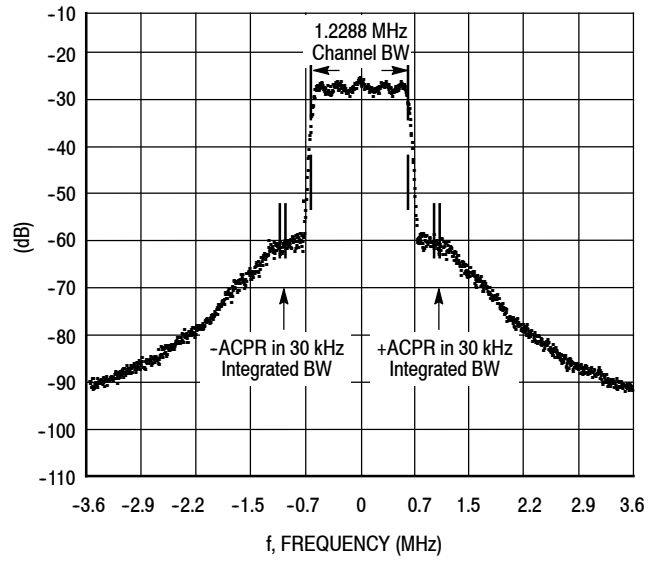

**Figure 20. Single-Carrier N-CDMA ACPR and Drain Efficiency versus Output Power**

## N-CDMA TEST SIGNAL

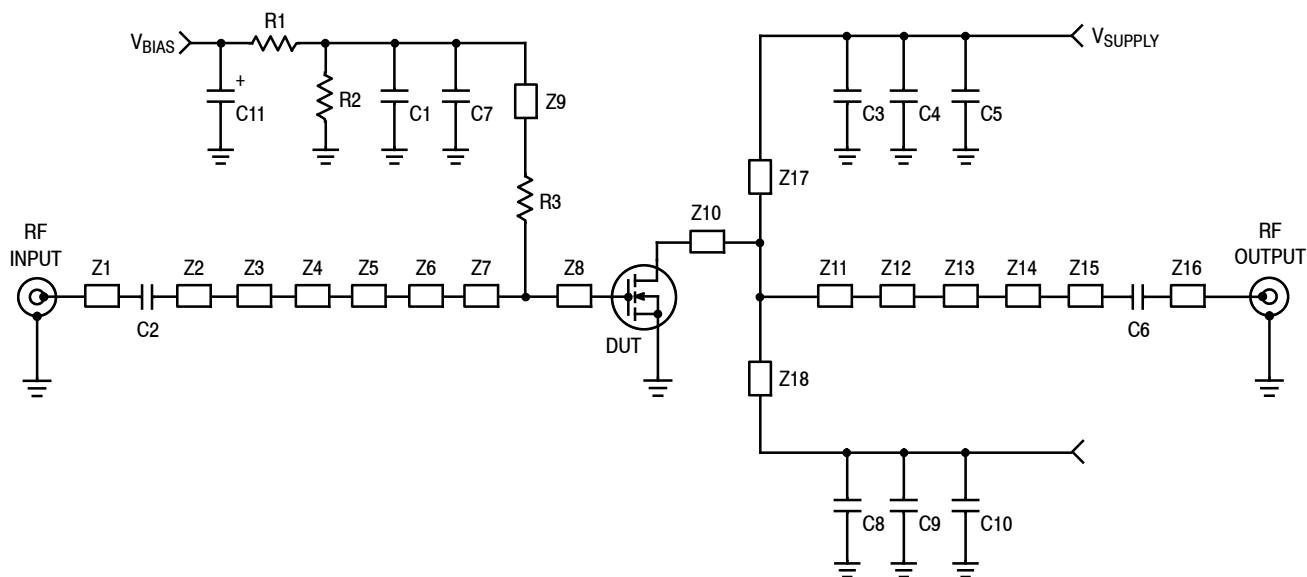

**Figure 21. Single-Carrier CCDF N-CDMA**



**Figure 22. Single-Carrier N-CDMA Spectrum**

## GSM EDGE TYPICAL CHARACTERISTICS — 1805-1880 MHz



Z1, Z16	0.066" x 0.480" Microstrip	Z10	1.142" x 0.350" Microstrip
Z2	0.066" x 0.137" Microstrip	Z11	1.142" x 0.516" Microstrip
Z3	0.236" x 0.236" Microstrip	Z12	0.433" x 0.276" Microstrip
Z4	0.066" x 0.354" Microstrip	Z13	0.276" x 0.157" Microstrip
Z5	0.551" x 0.512" Microstrip	Z14	0.236" x 0.433" Microstrip
Z6	0.066" x 0.079" Microstrip	Z15	0.066" x 0.104" Microstrip
Z7	0.591" x 0.189" Microstrip	Z17, Z18	0.050" x 1.250" Microstrip
Z8	0.591" x 0.334" Microstrip	PCB	Taconic RF-35, 0.030", $\epsilon_r = 3.5$
Z9	0.050" x 0.980" Microstrip		

**Figure 23. MRF6S20010NR1 Test Circuit Schematic — 1805-1880 MHz**

**Table 8. MRF6S20010NR1 Test Circuit Component Designations and Values — 1805-1880 MHz**

Part	Description	Part Number	Manufacturer
C1	100 nF Chip Capacitor	12065C104KAT	AVX
C2, C6	4.7 pF Chip Capacitors	ATC100B4R7BT500XT	ATC
C3, C7, C8	9.1 pF Chip Capacitors	ATC100B9R1BT500XT	ATC
C4, C5, C9, C10	10 $\mu$ F Chip Capacitors	C5750X5R1H106MT	TDK
C11	10 $\mu$ F, 35 V Tantalum Chip Capacitor	TAJD106K035R	AVX
R1, R2	10 k $\Omega$ , 1/4 W Chip Resistors	CRCW12061001FKEA	Vishay
R3	10 $\Omega$ , 1/4 W Chip Resistor	CRCW120610R0FKEA	Vishay

GSM EDGE TYPICAL CHARACTERISTICS — 1805-1880 MHz

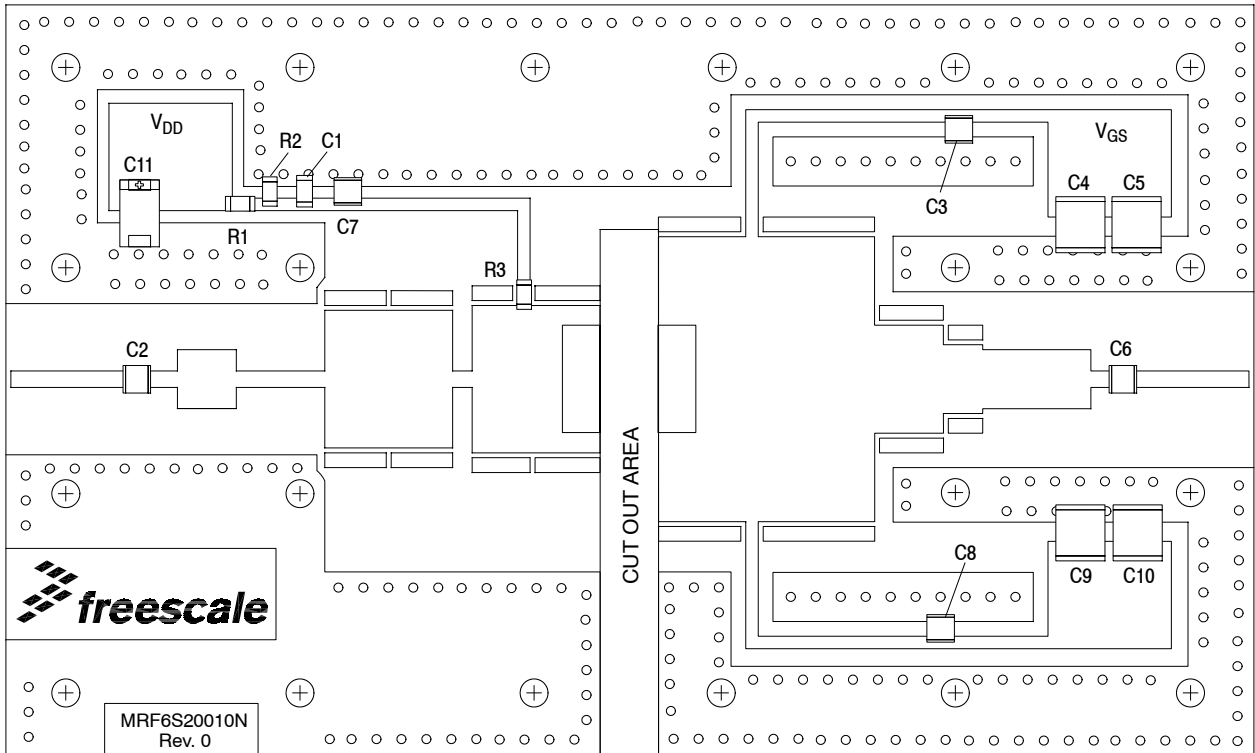
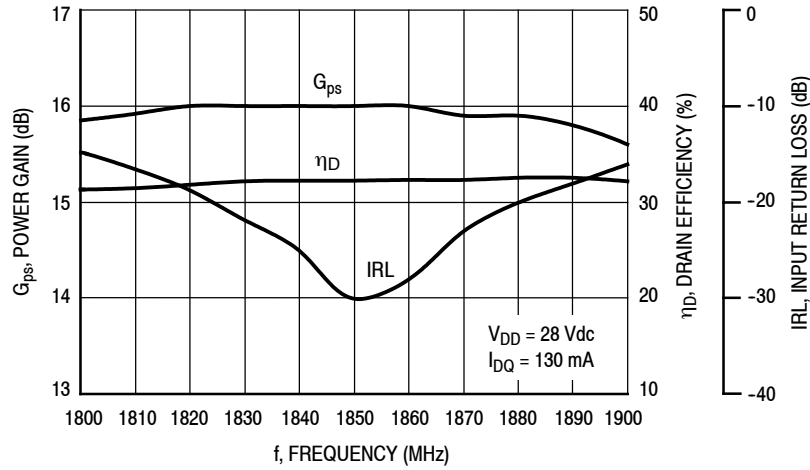
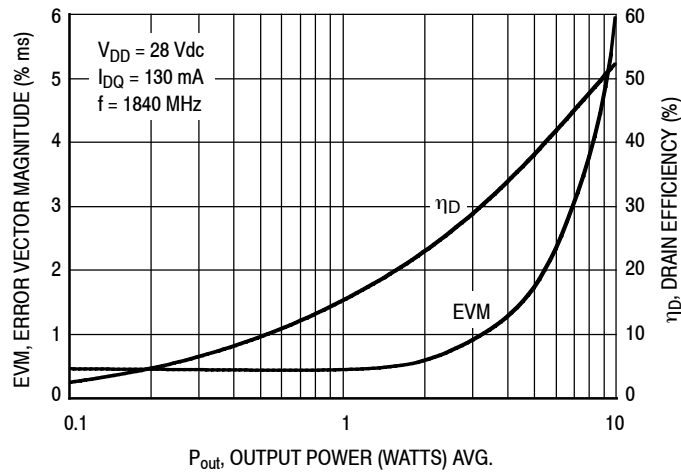

Figure 24. MRF6S20010NR1 Test Circuit Component Layout — 1805-1880 MHz

### GSM EDGE TYPICAL CHARACTERISTICS — 1805-1880 MHz

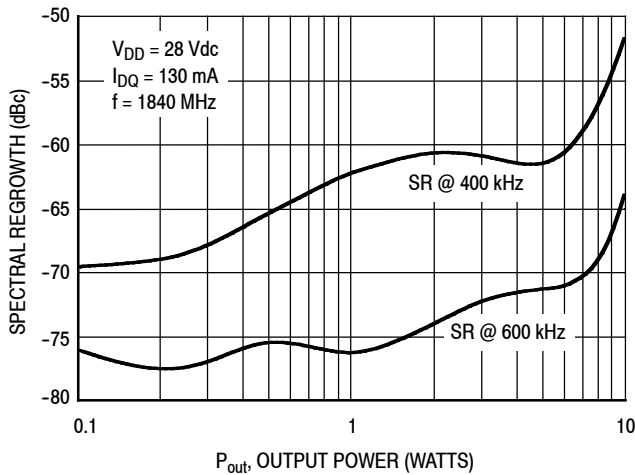

**Figure 25. Power Gain, Input Return Loss and Drain Efficiency versus Frequency @  $P_{out} = 4$  Watts**

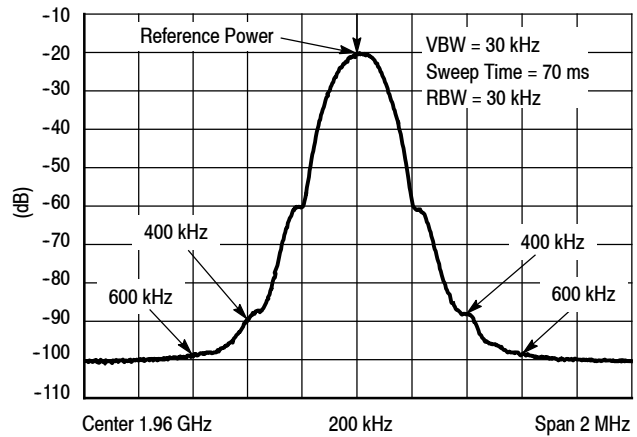

**Figure 26. Error Vector Magnitude and Drain Efficiency versus Output Power**

### GSM EDGE TEST SIGNAL



**Figure 27. Spectral Regrowth at 400 kHz and 600 kHz versus Output Power**



**Figure 28. EDGE Spectrum**

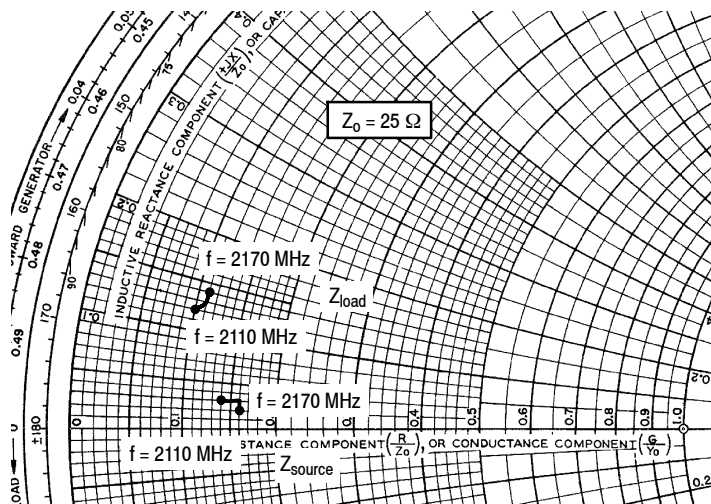

### 2170 MHz

$V_{DD} = 28 \text{ Vdc}$ ,  $I_{DQ} = 130 \text{ mA}$ ,  $P_{out} = 10 \text{ W PEP}$

f MHz	$Z_{source}$ $\Omega$	$Z_{load}$ $\Omega$
2110	$3.619 + j0.792$	$2.544 + j3.068$
2140	$3.918 + j0.797$	$2.673 + j3.291$
2170	$4.087 + j0.558$	$2.818 + j3.406$

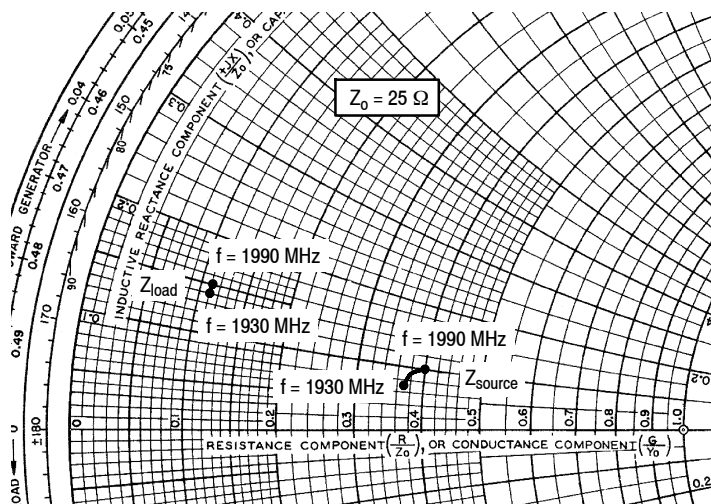

### 1900 MHz

$V_{DD} = 28 \text{ Vdc}$ ,  $I_{DQ} = 130 \text{ mA}$ ,  $P_{out} = 1 \text{ W Avg.}$

f MHz	$Z_{source}$ $\Omega$	$Z_{load}$ $\Omega$
1930	$9.237 + j1.849$	$2.770 + j3.497$
1960	$9.521 + j2.144$	$2.754 + j3.668$
1990	$9.889 + j2.434$	$2.772 + j3.833$

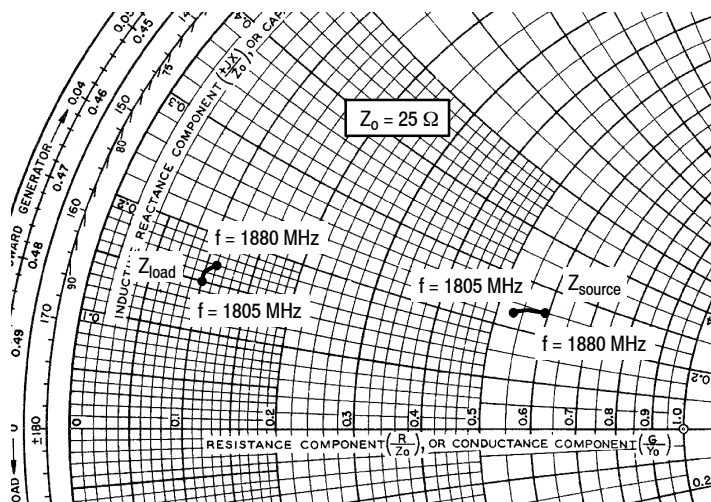

### 1800 MHz

$V_{DD} = 28 \text{ Vdc}$ ,  $I_{DQ} = 130 \text{ mA}$ ,  $P_{out} = 4 \text{ W Avg.}$

f MHz	$Z_{source}$ $\Omega$	$Z_{load}$ $\Omega$
1805	$13.237 + j5.810$	$2.445 + j3.698$
1840	$13.953 + j6.084$	$2.542 + j3.942$
1880	$14.858 + j6.279$	$2.695 + j4.170$

$Z_{source}$  = Test circuit impedance as measured from gate to ground.

$Z_{load}$  = Test circuit impedance as measured from drain to ground.

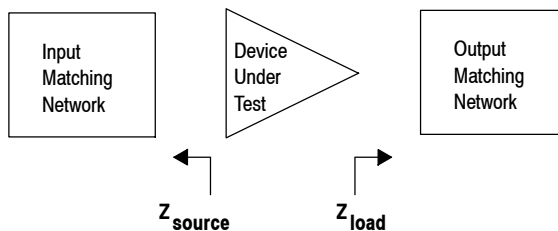

Figure 29. Series Equivalent Source and Load Impedance

**Table 9. Common Source Scattering Parameters** ( $V_{DD} = 28\text{ V}$ ,  $I_{DQ} = 126\text{ mA}$ ,  $T_A = 25^\circ\text{C}$ , 50 ohm system)

f MHz	S <sub>11</sub>		S <sub>21</sub>		S <sub>12</sub>		S <sub>22</sub>	
	S <sub>11</sub>	∠ φ	S <sub>21</sub>	∠ φ	S <sub>12</sub>	∠ φ	S <sub>22</sub>	∠ φ
500	0.984	-178.1	1.195	42.42	0.001	-129.1	0.875	-116.3
550	0.986	-179.0	0.947	40.48	0.001	-159.2	0.892	-121.6
600	0.985	179.9	0.747	39.66	0.001	147.4	0.905	-125.9
650	0.986	178.9	0.581	39.89	0.001	119.1	0.913	-129.9
700	0.982	177.9	0.446	41.80	0.001	108.1	0.927	-133.4
750	0.983	177.2	0.336	46.70	0.002	102.9	0.935	-136.4
800	0.983	176.5	0.248	56.02	0.002	96.99	0.941	-139.5
850	0.979	175.5	0.188	72.74	0.003	97.40	0.947	-141.9
900	0.980	174.8	0.168	96.69	0.003	94.63	0.951	-144.4
950	0.977	174.0	0.183	119.3	0.004	91.92	0.955	-146.6
1000	0.978	173.2	0.223	134.3	0.004	92.80	0.960	-148.6
1050	0.972	172.4	0.276	142.2	0.004	89.92	0.962	-150.5
1100	0.972	171.4	0.335	146.4	0.005	89.90	0.966	-152.2
1150	0.963	170.8	0.396	148.5	0.005	87.51	0.977	-153.7
1200	0.964	169.9	0.461	148.8	0.006	89.25	0.971	-155.2
1250	0.956	169.0	0.531	148.2	0.007	86.98	0.977	-156.8
1300	0.948	167.8	0.604	146.9	0.007	85.08	0.982	-157.9
1350	0.939	167.0	0.685	144.8	0.008	82.40	0.986	-159.5
1400	0.927	165.7	0.772	142.2	0.008	79.69	0.988	-160.7
1450	0.910	164.5	0.869	138.7	0.009	77.79	0.994	-162.1
1500	0.889	163.2	0.975	134.7	0.010	75.79	0.991	-163.4
1550	0.861	161.9	1.093	129.7	0.010	72.86	0.993	-164.7
1600	0.821	160.9	1.221	123.8	0.011	69.89	0.996	-166.0
1650	0.780	160.1	1.356	116.7	0.012	63.71	0.984	-167.4
1700	0.722	160.6	1.491	108.3	0.013	57.70	0.985	-168.5
1750	0.666	162.5	1.606	98.77	0.014	49.85	0.977	-169.6
1800	0.618	167.0	1.687	88.09	0.014	41.19	0.970	-170.8
1850	0.603	173.3	1.706	76.98	0.013	32.65	0.958	-171.3
1900	0.614	179.7	1.673	66.08	0.012	25.40	0.954	-171.9
1950	0.654	-175.6	1.591	55.96	0.011	20.73	0.945	-172.3
2000	0.701	-173.5	1.484	47.04	0.010	15.11	0.947	-172.6
2050	0.747	-172.7	1.364	39.29	0.008	10.13	0.947	-173.0
2100	0.783	-172.6	1.242	32.87	0.006	6.333	0.945	-173.6
2150	0.816	-172.9	1.136	27.69	0.004	15.63	0.944	-173.9
2200	0.842	-173.6	1.042	23.26	0.004	42.20	0.944	-174.2
2250	0.864	-174.2	0.961	19.26	0.005	57.76	0.948	-174.6
2300	0.882	-175.0	0.888	15.75	0.006	62.56	0.948	-175.2
2350	0.894	-175.7	0.822	12.69	0.008	59.72	0.949	-175.7
2400	0.906	-176.4	0.764	9.857	0.009	49.09	0.951	-176.1
2450	0.910	-176.9	0.712	7.587	0.008	39.24	0.955	-176.5

(continued)

**Table 9. Common Source Scattering Parameters** ( $V_{DD} = 28\text{ V}$ ,  $I_{DQ} = 126\text{ mA}$ ,  $T_A = 25^\circ\text{C}$ , 50 ohm system) (continued)

f MHz	S <sub>11</sub>		S <sub>21</sub>		S <sub>12</sub>		S <sub>22</sub>	
	S <sub>11</sub>	∠ φ	S <sub>21</sub>	∠ φ	S <sub>12</sub>	∠ φ	S <sub>22</sub>	∠ φ
2500	0.923	-177.5	0.666	5.462	0.006	42.56	0.957	-177.2
2550	0.927	-178.0	0.625	3.680	0.006	52.25	0.962	-177.8
2600	0.937	-178.8	0.591	1.864	0.006	60.26	0.961	-178.4
2650	0.937	-179.0	0.559	0.237	0.007	64.14	0.964	-179.1
2700	0.942	-179.8	0.529	-1.378	0.007	65.62	0.964	-179.6
2750	0.945	-179.9	0.504	-2.768	0.007	64.71	0.964	179.7
2800	0.946	179.5	0.479	-4.088	0.007	67.58	0.966	179.4
2850	0.950	179.3	0.456	-5.412	0.007	75.44	0.966	178.8
2900	0.949	178.8	0.436	-6.305	0.008	82.04	0.964	178.3
2950	0.952	178.5	0.419	-7.279	0.009	83.60	0.967	177.9
3000	0.950	178.4	0.402	-8.087	0.011	83.41	0.968	177.4
3050	0.958	177.9	0.387	-9.138	0.012	81.35	0.964	176.8
3100	0.953	177.7	0.373	-9.904	0.013	77.45	0.969	176.4
3150	0.957	177.2	0.362	-10.86	0.014	70.98	0.970	176.2
3200	0.960	177.4	0.350	-11.79	0.013	67.00	0.970	175.5

**PACKAGE DIMENSIONS**

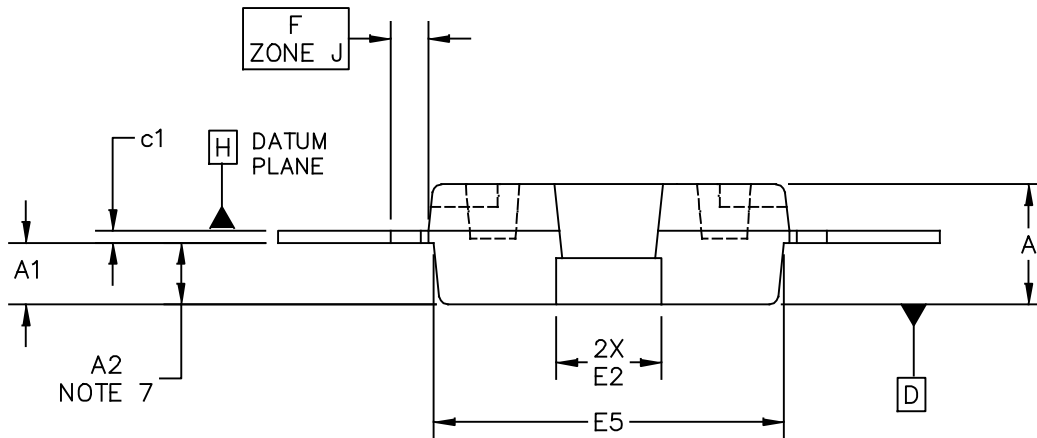
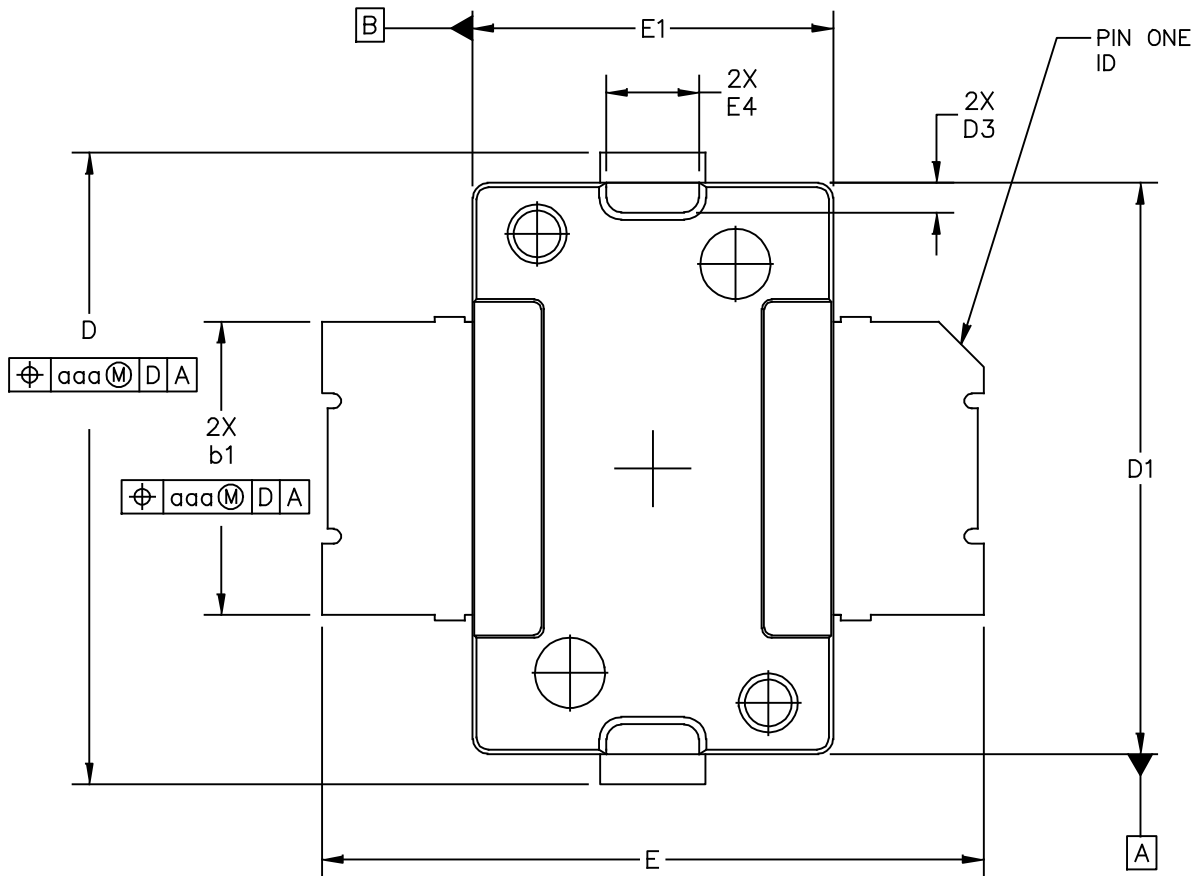

© FREESCALE SEMICONDUCTOR, INC. ALL RIGHTS RESERVED.		MECHANICAL OUTLINE		PRINT VERSION NOT TO SCALE	
TITLE: <b>TO-270 SURFACE MOUNT</b>		DOCUMENT NO: 98ASH98117A		REV: K	
		CASE NUMBER: 1265-09		29 JUN 2007	
		STANDARD: JEDEC TO-270 AA			

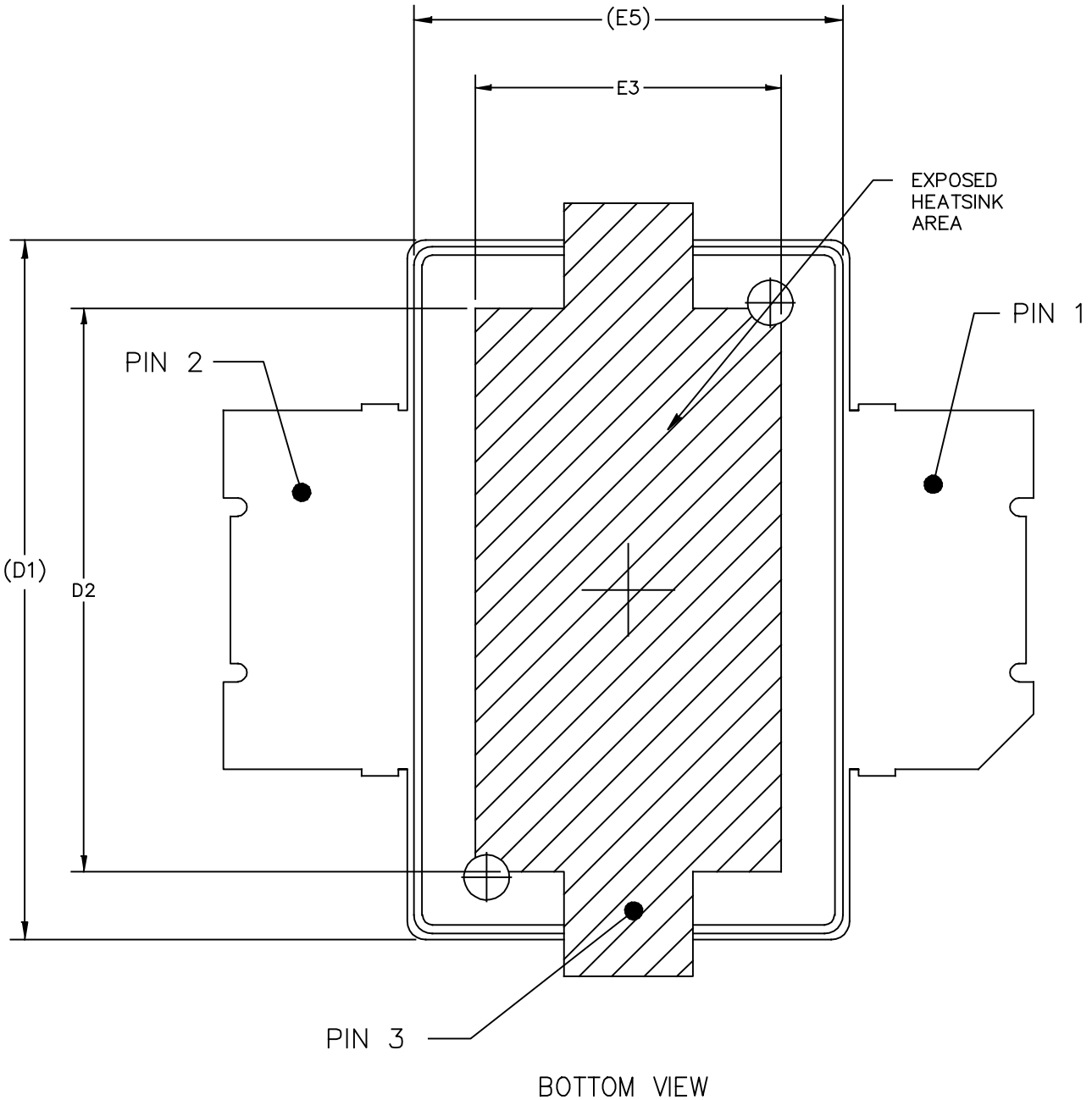

© FREESCALE SEMICONDUCTOR, INC. ALL RIGHTS RESERVED.	MECHANICAL OUTLINE	PRINT VERSION NOT TO SCALE	
TITLE: <div style="text-align: center; padding: 5px;"> <b>TO-270 SURFACE MOUNT</b> </div>	DOCUMENT NO: 98ASH98117A	REV: K	
	CASE NUMBER: 1265-09	29 JUN 2007	
	STANDARD: JEDEC TO-270 AA		

NOTES:

1. CONTROLLING DIMENSION: INCH
2. INTERPRET DIMENSIONS AND TOLERANCES PER ASME Y14.5M-1994.
3. DATUM PLANE -H- IS LOCATED AT TOP OF LEAD AND IS COINCIDENT WITH THE LEAD WHERE THE LEAD EXITS THE PLASTIC BODY AT THE TOP OF THE PARTING LINE.
4. DIMENSIONS "D1" AND "E1" DO NOT INCLUDE MOLD PROTRUSION. ALLOWABLE PROTRUSION IS .006 PER SIDE. DIMENSIONS "D1 AND "E1" DO INCLUDE MOLD MISMATCH AND ARE DETERMINED AT DATUM PLANE -H-.
5. DIMENSION "b1" DOES NOT INCLUDE DAMBAR PROTRUSION. ALLOWABLE DAMBAR PROTRUSION SHALL BE .005 TOTAL IN EXCESS OF THE "b1" DIMENSION AT MAXIMUM MATERIAL CONDITION.
6. DATUMS -A- AND -B- TO BE DETERMINED AT DATUM PLANE -H-.
7. DIMENSION "A2" APPLIES WITHIN ZONE "J" ONLY.
8. DIMENSIONS "D" AND "E2" DO NOT INCLUDE MOLD PROTRUSION. OVERALL LENGTH INCLUDING MOLD PROTRUSION SHOULD NOT EXCEED 0.430 INCH FOR DIMENSION "D" AND 0.080 INCH FOR DIMENSION "E2". DIMENSIONS "D" AND "E2" DO INCLUDE MOLD MISMATCH AND ARE DETERMINED AT DATUM PLANE -D-.

STYLE 1:

- PIN 1 - DRAIN
- PIN 2 - GATE
- PIN 3 - SOURCE

DIM	INCH		MILLIMETER		DIM	INCH		MILLIMETER	
	MIN	MAX	MIN	MAX		MIN	MAX	MIN	MAX
A	.078	.082	1.98	2.08	F	.025 BSC		0.64 BSC	
A1	.039	.043	0.99	1.09	b1	.193	.199	4.90	5.06
A2	.040	.042	1.02	1.07	c1	.007	.011	0.18	0.28
D	.416	.424	10.57	10.77	aaa	.004		0.10	
D1	.378	.382	9.60	9.70					
D2	.290	----	7.37	----					
D3	.016	.024	0.41	0.61					
E	.436	.444	11.07	11.28					
E1	.238	.242	6.04	6.15					
E2	.066	.074	1.68	1.88					
E3	.150	----	3.81	----					
E4	.058	.066	1.47	1.68					
E5	.231	.235	5.87	5.97					

© FREESCALE SEMICONDUCTOR, INC. ALL RIGHTS RESERVED.		MECHANICAL OUTLINE		PRINT VERSION NOT TO SCALE	
TITLE:  TO-270 SURFACE MOUNT			DOCUMENT NO: 98ASH98117A		REV: K
			CASE NUMBER: 1265-09		29 JUN 2007
			STANDARD: JEDEC TO-270 AA		

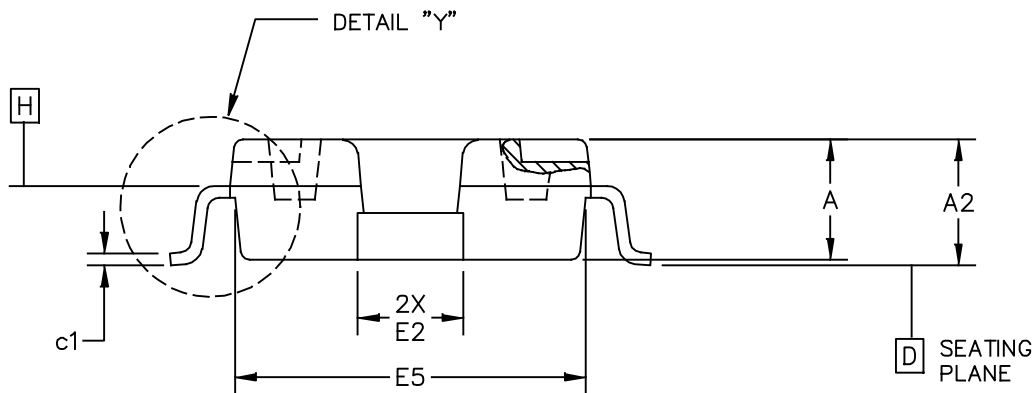
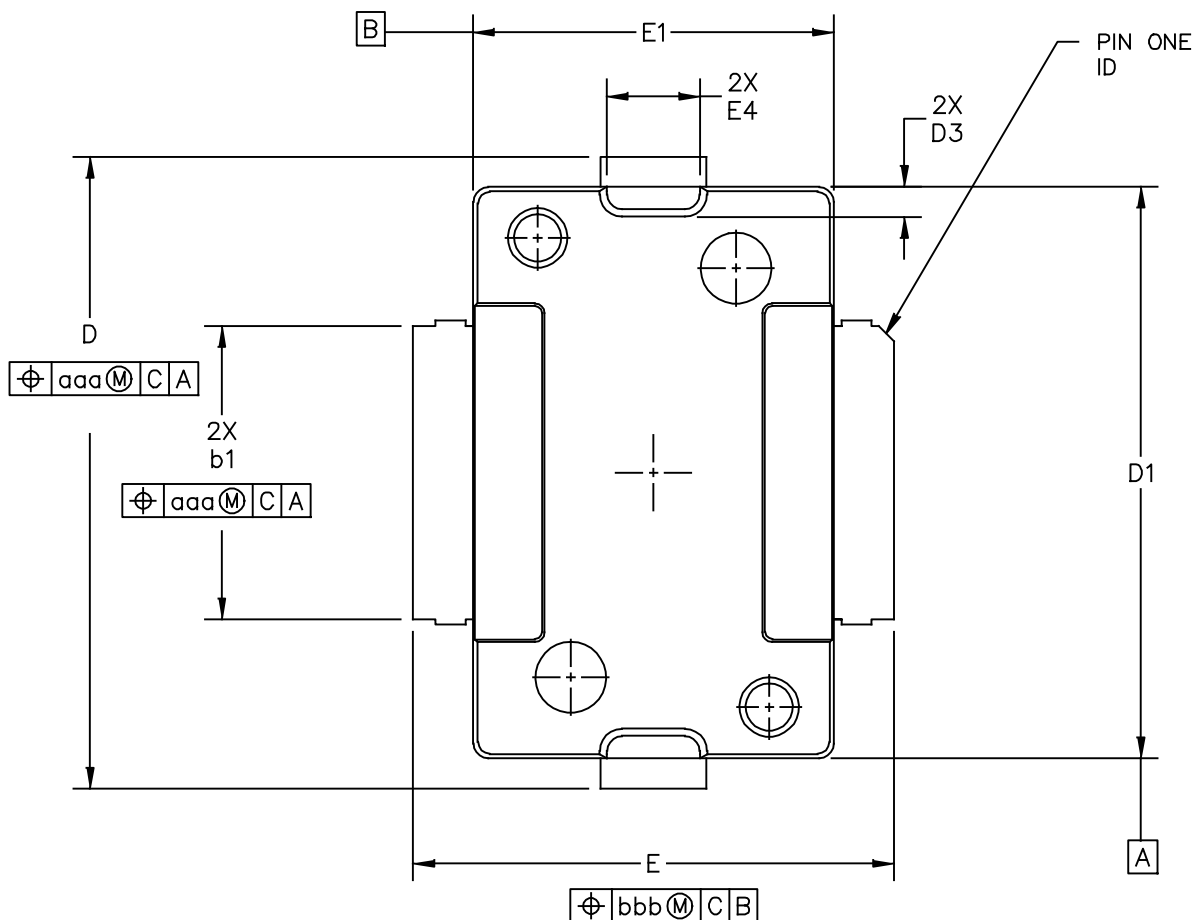

© FREESCALE SEMICONDUCTOR, INC. ALL RIGHTS RESERVED.		MECHANICAL OUTLINE	PRINT VERSION NOT TO SCALE
TITLE: TO-270 GULL WING		DOCUMENT NO: 98ASA99301D	REV: C
		CASE NUMBER: 1265A-03	02 JUL 2007
		STANDARD: JEDEC TO-270 BA	

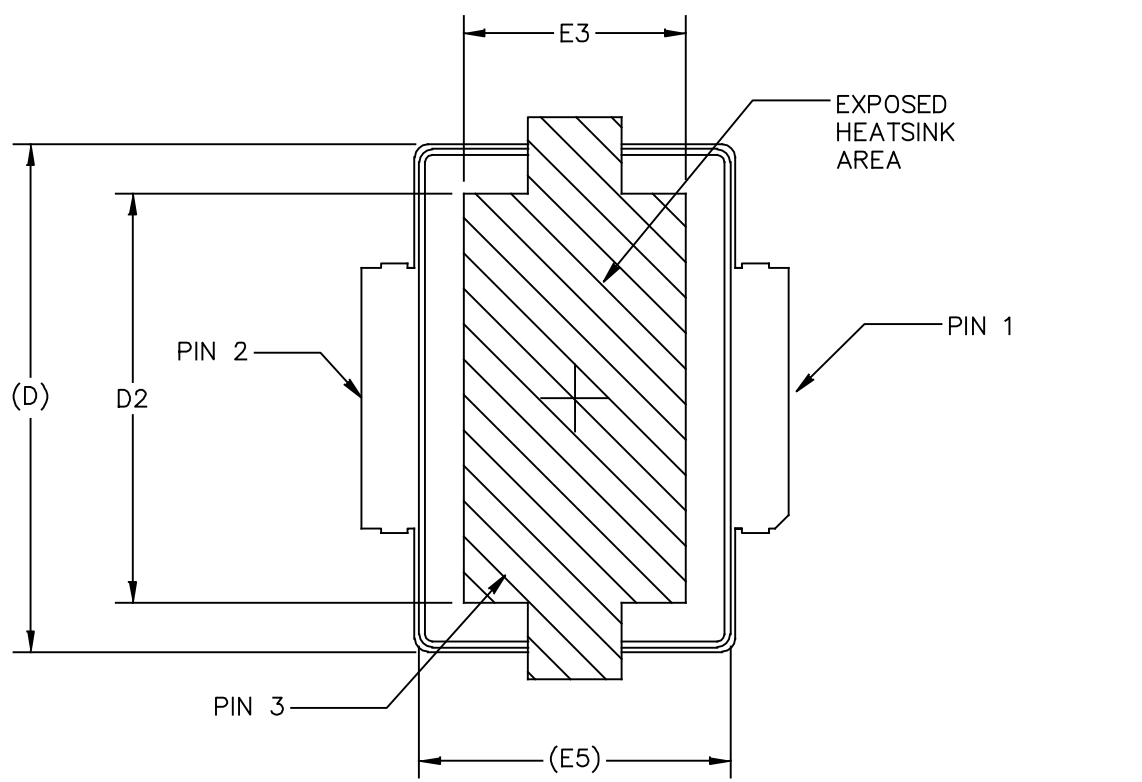

BOTTOM VIEW

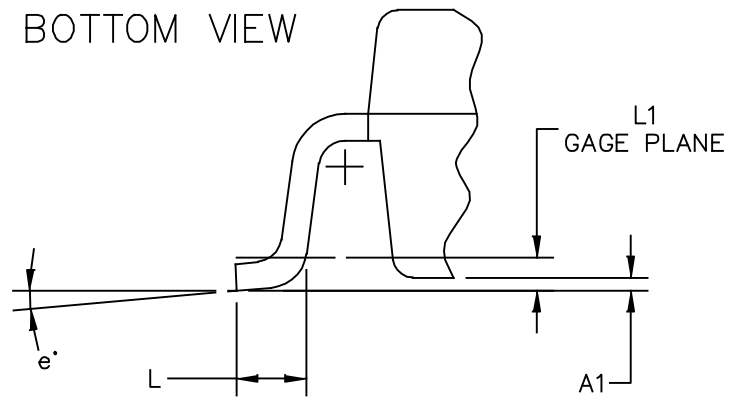

DETAIL "Y"

© FREESCALE SEMICONDUCTOR, INC. ALL RIGHTS RESERVED.	MECHANICAL OUTLINE	PRINT VERSION NOT TO SCALE	
TITLE:  TO-270 GULL WING	DOCUMENT NO: 98ASA99301D		REV: C
	CASE NUMBER: 1265A-03		02 JUL 2007
	STANDARD: JEDEC TO-270 BA		

NOTES:

1. CONTROLLING DIMENSION: INCH
2. INTERPRET DIMENSIONS AND TOLERANCES PER ASME Y14.5M-1994.
3. DATUM PLANE -H- IS LOCATED AT TOP OF LEAD AND IS COINCIDENT WITH THE LEAD WHERE THE LEAD EXITS THE PLASTIC BODY AT THE TOP OF THE PARTING LINE.
4. DIMENSIONS "D1" AND "E1" DO NOT INCLUDE MOLD PROTRUSION. ALLOWABLE PROTRUSION IS .006 PER SIDE. DIMENSIONS "D1 AND "E1" DO INCLUDE MOLD MISMATCH AND ARE DETERMINED AT DATUM PLANE -H-.
5. DIMENSION b1 DOES NOT INCLUDE DAMBAR PROTRUSION. ALLOWABLE DAMBAR PROTRUSION SHALL BE .005 TOTAL IN EXCESS OF THE b1 DIMENSION AT MAXIMUM MATERIAL CONDITION.
6. DATUMS -A- AND -B- TO BE DETERMINED AT DATUM PLANE -H-.
7. DIMENSIONS "D" AND "E2" DO NOT INCLUDE MOLD PROTRUSION. ALLOWABLE PROTRUSION IS .003 PER SIDE. DIMENSIONS "D AND "E2" DO INCLUDE MOLD MISMATCH AND ARE DETERMINED AT DATUM PLANE -D-.

STYLE 1:

- PIN 1 - DRAIN
- PIN 2 - GATE
- PIN 3 - SOURCE

DIM	INCH		MILLIMETER		DIM	INCH		MILLIMETER	
	MIN	MAX	MIN	MAX		MIN	MAX	MIN	MAX
A	.078	.082	1.98	2.08	L	.018	.024	0.46	0.61
A1	.001	.004	0.02	0.10	L1	.01 BSC		0.25 BSC	
A2	.077	.088	1.96	2.24	b1	.193	.199	4.90	5.06
D	.416	.424	10.57	10.77	c1	.007	.011	0.18	0.28
D1	.378	.382	9.60	9.70	e	2'	8'	2'	8'
D2	.290	-	7.37	-	aaa	.004		0.10	
D3	.016	.024	0.41	0.61					
E	.316	.324	8.03	8.23					
E1	.238	.242	6.04	6.15					
E2	.066	.074	1.68	1.88					
E3	.150	-	3.81	-					
E4	.058	.066	1.47	1.68					
E5	.231	.235	5.87	5.97					
© FREESCALE SEMICONDUCTOR, INC. ALL RIGHTS RESERVED.			MECHANICAL OUTLINE			PRINT VERSION NOT TO SCALE			
TITLE:  TO-270 GULL WING					DOCUMENT NO: 98ASA99301D			REV: C	
					CASE NUMBER: 1265A-03			02 JUL 2007	
					STANDARD: JEDEC TO-270 BA				

Refer to the following documents to aid your design process.

**Application Notes**

- AN1907: Solder Reflow Attach Method for High Power RF Devices in Plastic Packages
- AN1955: Thermal Measurement Methodology of RF Power Amplifiers
- AN3789: Clamping of High Power RF Transistors and RFICs in Over-Molded Plastic Packages

**Engineering Bulletins**

- EB212: Using Data Sheet Impedances for RF LDMOS Devices

**Software**

- Electromigration MTTF Calculator
- RF High Power Model

For Software and Tools, do a Part Number search at <http://www.freescale.com>, and select the “Part Number” link. Go to the Software & Tools tab on the part’s Product Summary page to download the respective tool.

**REVISION HISTORY**

The following table summarizes revisions to this document.

Revision	Date	Description
2	Dec. 2008	<ul style="list-style-type: none"> <li>• Changed Storage Temperature Range in Max Ratings table from -65 to +175 to -65 to +150 for standardization across products, p. 1</li> <li>• Added Case Operating Temperature limit to the Maximum Ratings table and set limit to 150°C, p. 1</li> <li>• Operating Junction Temperature increased from 200°C to 225°C in Maximum Ratings table, related “Continuous use at maximum temperature will affect MTTF” footnote added and changed 200°C to 225°C in Capable Plastic Package bullet, p. 1</li> <li>• Corrected <math>V_{DS}</math> to <math>V_{DD}</math> in the RF test condition voltage callout for <math>V_{GS(Q)}</math>, On Characteristics table, p. 2</li> <li>• Corrected <math>C_{iss}</math> test condition to indicate AC stimulus on the <math>V_{GS}</math> connection versus the <math>V_{DS}</math> connection, Dynamic Characteristics table, p. 2</li> <li>• Updated Part Numbers in Tables 6, 7, 8, Component Designations and Values, to RoHS compliant part numbers, p. 4, 10, 14</li> <li>• Adjusted scale for Fig. 7, Intermodulation Distortion Products versus Tone Spacing, to better match the device’s capabilities, p. 6</li> <li>• Removed lower voltage tests from Fig. 10, Power Gain versus Output Power, due to fixed tuned fixture limitations, p. 7</li> <li>• Replaced Fig. 12, MTTF versus Junction Temperature with updated graph. Removed Amps<sup>2</sup> and listed operating characteristics and location of MTTF calculator for device, p. 7</li> <li>• Removed ALT1 definition from Fig. 21, Single-Carrier CCDF N-CDMA, given no supporting performance information provided, p. 13</li> <li>• Replaced Case Outline 1265-08 with 1265-09, Issue K, p. 1, 20-22. Corrected cross hatch pattern in bottom view and changed its dimensions (D2 and E3) to minimum value on source contact (D2 changed from Min-Max .290-.320 to .290 Min; E3 changed from Min-Max .150-.180 to .150 Min). Added JEDEC Standard Package Number.</li> <li>• Replaced Case Outline 1265A-02 with 1265A-03, Issue C, p. 1, 23-25. Corrected cross hatch pattern and its dimensions (D2 and E2) on source contact (D2 changed from Min-Max .290-.320 to .290 Min; E3 changed from Min-Max .150-.180 to .150 Min). Added pin numbers. Corrected mm dimension L for gull-wing foot from 4.90-5.06 Min-Max to 0.46-0.61 Min-Max. Added JEDEC Standard Package Number.</li> <li>• Added Product Documentation and Revision History, p. 26</li> </ul>
3	June 2009	<ul style="list-style-type: none"> <li>• Corrected decimal placement for <math>C_{iss}</math> (changed 0.12 pF to 120 pF) and <math>C_{oss}</math> (changed 0.02 pF to 20 pF), Dynamic Characteristics table, p. 2</li> <li>• Added footnote, Measurement made with device in straight lead configuration before any lead forming operation is applied, to Functional Tests table, p. 2.</li> <li>• Added AN3789, Clamping of High Power RF Transistors and RFICs in Over-Molded Plastic Packages to Product Documentation, Application Notes, p. 26</li> <li>• Added Electromigration MTTF Calculator and RF High Power Model availability to Product Software, p. 26</li> </ul>

(continued)

## REVISION HISTORY (cont.)

Revision	Date	Description
4	Jan. 2014	<ul style="list-style-type: none"> <li>• Table 2. Thermal Characteristics: CW thermal value changed from 2.5 to 2.3°C/W to reflect recent thermal test results; two-tone test W PEP thermal value changed from 5.9 to 2.9°C/W to reflect recent thermal test results. Thermal value changes are based on an improvement in the RF feedback resistor design, p. 2</li> <li>• Table 3, ESD Protection Characteristics, removed the word “Minimum” after the ESD class rating. ESD ratings are characterized during new product development but are not 100% tested during production. ESD ratings provided in the data sheet are intended to be used as a guideline when handling ESD sensitive devices, p. 2</li> <li>• Fig. 12, MTTF versus Junction Temperature removed, p. 7. Refer to the device’s MTTF Calculator available at <a href="http://freescale.com/RFpower">freescale.com/RFpower</a>. Go to Design Resources &gt; Software and Tools.</li> </ul>

### ***How to Reach Us:***

**Home Page:**  
[freescale.com](http://freescale.com)

**Web Support:**  
[freescale.com/support](http://freescale.com/support)

Information in this document is provided solely to enable system and software implementers to use Freescale products. There are no express or implied copyright licenses granted hereunder to design or fabricate any integrated circuits based on the information in this document.

Freescale reserves the right to make changes without further notice to any products herein. Freescale makes no warranty, representation, or guarantee regarding the suitability of its products for any particular purpose, nor does Freescale assume any liability arising out of the application or use of any product or circuit, and specifically disclaims any and all liability, including without limitation consequential or incidental damages. "Typical" parameters that may be provided in Freescale data sheets and/or specifications can and do vary in different applications, and actual performance may vary over time. All operating parameters, including "typicals," must be validated for each customer application by customer's technical experts. Freescale does not convey any license under its patent rights nor the rights of others. Freescale sells products pursuant to standard terms and conditions of sale, which can be found at the following address: [freescale.com/SalesTermsandConditions](http://freescale.com/SalesTermsandConditions).

Freescale and the Freescale logo are trademarks of Freescale Semiconductor, Inc., Reg. U.S. Pat. & Tm. Off. All other product or service names are the property of their respective owners.

© 2005–2006, 2008–2009, 2014 Freescale Semiconductor, Inc.

## Looking for pricing, stock, or lifecycle information?

Click below to explore more details on WIN SOURCE:

 [View MRF6S20010GNR1 on WIN SOURCE](#)

 [NXP / Nexperia Information](#)

## Optimize Your Supply Chain with WIN SOURCE Solutions

-  Global Sourcing Solution
-  Obsolete Management
-  Cost Control Management
-  Shortage Management
-  Alternative Solution
-  Excess Inventory Management