



**THE DATASHEET OF
NB2308AI1HDT**



NB2308A

3.3 V Zero Delay Clock Buffer

The NB2308A is a versatile, 3.3 V zero delay buffer designed to distribute high-speed clocks. It is available in a 16 pin package. The part has an on-chip PLL which locks to an input clock presented on the REF pin. The PLL feedback is required to be driven to FBK pin, and can be obtained from one of the outputs. The input-to-output propagation delay is guaranteed to be less than 250 ps, and the output-to-output skew is guaranteed to be less than 200 ps.

The NB2308A has two banks of four outputs each, which can be controlled by the select inputs as shown in the Select Input Decoding Table. If all the output clocks are not required, Bank B can be three-stated. The select input also allows the input clock to be directly applied to the outputs for chip and system testing purposes.

Multiple NB2308A devices can accept the same input clock and distribute it. In this case the skew between the outputs of the two devices is guaranteed to be less than 700 ps.

The NB2308A is available in five different configurations (Refer to NB2308A Configurations Table). The NB2308Ax1* is the base part, where the output frequencies equal the reference if there is no counter in the feedback path. The NB2308Ax1H is the high-drive version of the -1 and the rise and fall times on this device are much faster.

The NB2308Ax2 allows the user to obtain 2X and 1X frequencies on each output bank. The exact configuration and output frequencies depends on which output drives the feedback pin. The NB2308Ax3 allows the user to obtain 4X and 2X frequencies on the outputs.

The NB2308Ax4 enables the user to obtain 2X clocks on all outputs. Thus, the part is extremely versatile, and can be used in a variety of applications.

The NB2308Ax5H is a high-drive version with REF/2 on both banks.

Features

- Zero Input – Output Propagation Delay, Adjustable by Capacitive Load on FBK Input
- Multiple Configurations – Refer to NB2308A Configurations Table
- Input Frequency Range: 15 MHz to 133 MHz
- Multiple Low-Skew Outputs
- Output-Output Skew Less than 200 ps
- Device-Device Skew Less than 700 ps
- Two banks of four outputs, three-stateable by two select inputs
- Less than 200 ps Cycle-to-Cycle Jitter
- Available in 16-pin SOIC and TSSOP Packages
- 3.3V operation
- Advanced 0.35 μ CMOS Technology
- Pb-Free Packages are Available**

*x = C for Commercial; I for Industrial.

**For additional information on our Pb-Free strategy and soldering details, please download the ON Semiconductor Soldering and Mounting Techniques Reference Manual, SOLDERRM/D.



ON Semiconductor®

<http://onsemi.com>

MARKING DIAGRAMS*

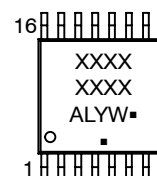

XXXX = Device Code
A = Assembly Location
WL, L = Wafer Lot
Y = Year
WW, W = Work Week
G or • = Pb-Free Package
(Note: Microdot may be in either location)

*For additional marking information, refer to Application Note AND8002/D.

ORDERING INFORMATION

See detailed ordering and shipping information in the package dimensions section on page 9 of this data sheet.

NB2308A

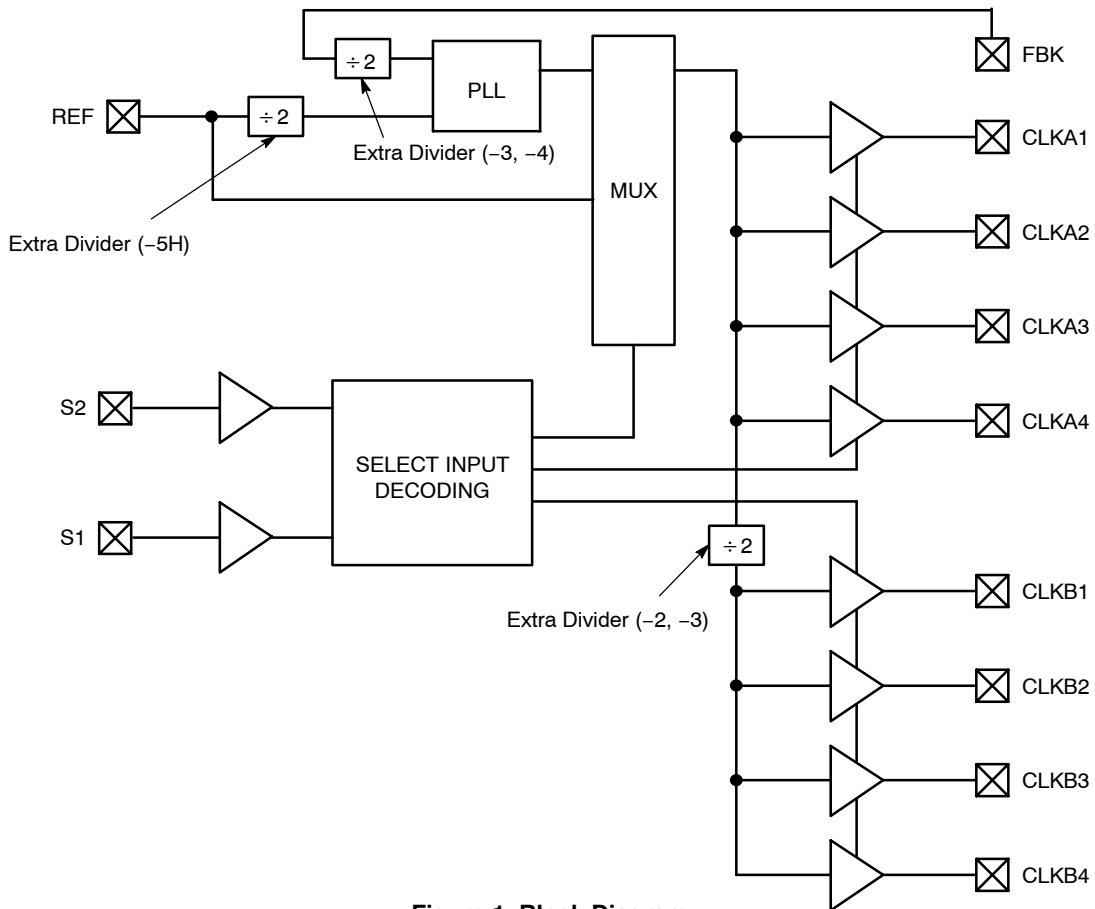

Figure 1. Block Diagram
(see Figures 11, 12, 13, 14 and 15 for device specific Block Diagrams)

Table 1. CONFIGURATIONS (x = C for Commercial; I for Industrial)

Device	Feedback From	Bank A Frequency	Bank B Frequency
NB2308Ax1	Bank A or Bank B	Reference	Reference
NB2308Ax1H	Bank A or Bank B	Reference	Reference
NB2308Ax2	Bank A	Reference	Reference $\div 2$
NB2308Ax2	Bank B	2 X Reference	Reference
NB2308Ax3	Bank A	2 X Reference	Reference or Reference (Note 1)
NB2308Ax3	Bank B	4 X Reference	2 X Reference
NB2308Ax4	Bank A or Bank B	2 X Reference	2 X Reference
NB2308Ax5H	Bank A or Bank B	Reference $\div 2$	Reference $\div 2$

1. Output phase is indeterminant (0° or 180° from input clock). If phase integrity is required, use the NB2308Ax2.

Table 2. SELECT INPUT DECODING

S2	S1	Clock A1 – A4	Clock B1 – B4	Output Source	PLL ShutDown
0	0	Three-state	Three-state	PLL	Y
0	1	Driven	Three-state	PLL	N
1	0	Driven (Note 2)	Driven	Reference	Y
1	1	Driven	Driven	PLL	N

2. Outputs inverted on 2308-2 and 2308-3 in bypass mode, S2 = 1 and S1 = 0.

NB2308A

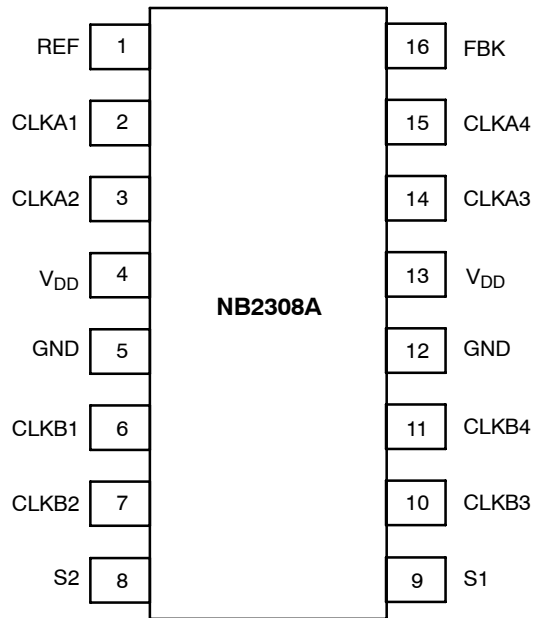

Figure 2. Pin Configuration

Table 3. PIN DESCRIPTION

Pin #	Pin Name	Description
1	REF (Note 3)	Input reference frequency, 5 V tolerant input.
2	CLKA1 (Note 4)	Buffered clock output, Bank A.
3	CLKA2 (Note 4)	Buffered clock output, Bank A.
4	V _{DD}	3.3 V supply.
5	GND	Ground.
6	CLKB1 (Note 4)	Buffered clock output, Bank B.
7	CLKB2 (Note 4)	Buffered clock output, Bank B.
8	S2 (Note 5)	Select input, bit 2.
9	S1 (Note 5)	Select input, bit 1.
10	CLKB3 (Note 4)	Buffered clock output, Bank B.
11	CLKB4 (Note 4)	Buffered clock output, Bank B.
12	GND	Ground.
13	V _{DD}	3.3 V supply.
14	CLKA3 (Note 4)	Buffered clock output, Bank A.
15	CLKA4 (Note 4)	Buffered clock output, Bank A.
16	FBK	PLL feedback input.

- 3. Weak pulldown.
- 4. Weak pulldown on all outputs.
- 5. Weak pullup on these inputs.

NB2308A

Table 4. MAXIMUM RATINGS

Parameter	Min	Max	Unit
Supply Voltage to Ground Potential	-0.5	+7.0	V
DC Input Voltage (Except REF)	-0.5	$V_{DD} + 0.5$	V
DC Input Voltage (REF)	-0.5	7	V
Storage Temperature	-65	+150	°C
Maximum Soldering Temperature (10 sec)		260	°C
Junction Temperature		150	°C
Static Discharge Voltage (per MIL-STD-883, Method 3015)		>2000	V

Maximum ratings are those values beyond which device damage can occur. Maximum ratings applied to the device are individual stress limit values (not normal operating conditions) and are not valid simultaneously. If these limits are exceeded, device functional operation is not implied, damage may occur and reliability may be affected.

Table 5. OPERATING CONDITIONS FOR COMMERCIAL AND INDUSTRIAL TEMPERATURE DEVICES

Parameter	Description		Min	Max	Unit
V_{DD}	Supply Voltage		3.0	3.6	V
T_A	Operating Temperature (Ambient Temperature)	Commercial Industrial	0 -40	70 85	°C
C_L	Load Capacitance, below 100 MHz			30	pF
C_L	Load Capacitance, from 100 MHz to 133 MHz			15	pF
C_{IN}	Input Capacitance (Note 6)			7	pF

6. Applies to both REF Clock and FBK.

Table 6. ELECTRICAL CHARACTERISTICS FOR COMMERCIAL AND INDUSTRIAL TEMPERATURE DEVICES

Parameter	Description	Test Conditions	Min	Max	Unit	
V_{IL}	Input LOW Voltage			0.8	V	
V_{IH}	Input HIGH Voltage		2.0		V	
I_{IL}	Input LOW Current	$V_{IN} = 0\text{ V}$		50.0	μA	
I_{IH}	Input HIGH Current	$V_{IN} = V_{DD}$		100.0	μA	
V_{OL}	Output LOW Voltage	$I_{OL} = 8\text{ mA}$ (-1, -2, -3, -4) $I_{OL} = 12\text{ mA}$ (-1H, -5H)		0.4	V	
V_{OH}	Output HIGH Voltage	$I_{OH} = -8\text{ mA}$ (-1, -2, -3, -4) $I_{OH} = -12\text{ mA}$ (-1H, -5H)	2.4		V	
I_{DD}	Supply Current (Note 7)	Unloaded outputs 100 MHz REF	-2, -3, -4		49	mA
		Select inputs at V_{DD} or GND	-1H, -5H		60	mA
		Unloaded outputs, 66 MHz REF (-1, -2, -3, -4)			34	mA
		Unloaded outputs, 33 MHz REF (-1, -2, -3, -4)			18	mA

7. Supply currents are measured for PLL-Bypass Mode ($S2 = 1$, $S1 = 0$).

NB2308A

Table 7. SWITCHING CHARACTERISTICS FOR COMMERCIAL AND INDUSTRIAL TEMPERATURE DEVICES

Parameter	Description	Test Conditions	Min	Typ	Max	Unit
t ₁	Output Frequency	30 pF load (all devices)	15		100	MHz
		15 pF load (-1H, -5H)	15		133.3	
		15 pF load (-1, -2, -3, -4)	15		133.3	
t ₁	Duty Cycle = (t ₂ / t ₁) * 100 (all devices)	Measured at 1.4 V, F _{OUT} = < 66.66 MHz 30 pF load	40.0	50.0	60.0	%
		Measured at 1.4 V, F _{OUT} = < 50 MHz 15 pF load	45.0	50.0	55.0	
t ₃	Output Rise Time (-1, -2, -3, -4)	Measured between 0.8 V and 2.0 V 30 pF load			2.20	ns
		Measured between 0.8 V and 2.0 V 15 pF load			1.50	
	Output Rise Time (-1H, -5H)	Measured between 0.8 V and 2.0 V 30 pF load			1.50	
t ₄	Output Fall Time (-1, -2, -3, -4)	Measured between 2.0 V and 0.8 V 30 pF load			2.20	ns
		Measured between 0.8 V and 2.0 V 15 pF load			1.50	
	Output Fall Time (-1H, -5H)	Measured between 2.0 V and 0.8 V 30 pF load			1.25	
t ₅	Output-to-Output Skew on same Bank (-1, -2, -3, -4)	All outputs equally loaded			200	ps
	Output-to-Output Skew (-1H, -5H)	All outputs equally loaded			200	
	Output Bank A-to-Output Bank B Skew (-1, -4, -5H)	All outputs equally loaded			200	
	Output Bank A-to-Output Bank B Skew (-2, -3)	All outputs equally loaded			400	
t ₆	Delay, REF Rising Edge to FBK Rising Edge	Measured at V _{DD} /2		0	±250	ps
t ₇	Device-to-Device Skew	Measured at V _{DD} /2 on the FBK pins of the device		0	700	ps
t _J	Cycle-to-Cycle Jitter (-1, -1H, -4, -5H)	Measured at 66.67 MHz, loaded outputs, 15 pF load			200	ps
		Measured at 66.67 MHz, loaded outputs, 30 pF load			200	
		Measured at 133.3 MHz, loaded outputs 15 pF load			100	
	Cycle-to-Cycle Jitter (-2, -3)	Measured at 66.67 MHz, loaded outputs, 30 pF load			400	
		Measured at 66.67 MHz, loaded outputs, 15 pF load			400	
t _{LOCK}	PLL Lock Time	Stable power supply, valid clock presented on REF and FBK pins			1.0	ms

Zero Delay and Skew Control

All outputs should be uniformly loaded to achieve Zero Delay between input and output.

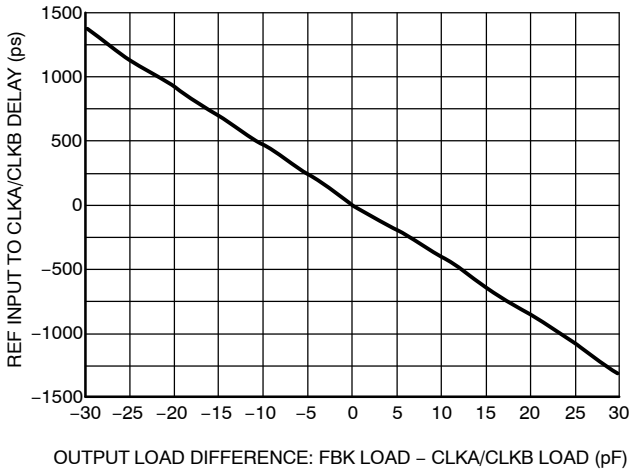

Figure 3. REF Input to CLKA/CLKB Delay vs. Difference in Loading between FBK Pin and CLKA/CLKB Pins

To close the feedback loop of the NB2308A, the FBK pin can be driven from any of the eight available output pins. The output driving the FBK pin will be driving a total load of 7 pF plus any additional load that it drives. The relative loading of this output (with respect to the remaining outputs) can adjust the input-output delay. This is shown in Figure 3.

For applications requiring zero input-output delay, all outputs including the one providing feedback should be equally loaded. If input-output delay adjustments are required, use the above graph to calculate loading differences between the feedback output and remaining outputs. For zero output-output skew, be sure to load outputs equally.

SWITCHING WAVEFORMS

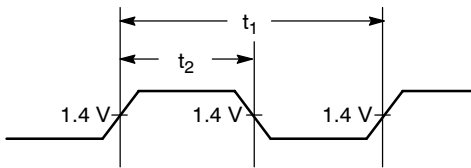

Figure 4. Duty Cycle Timing

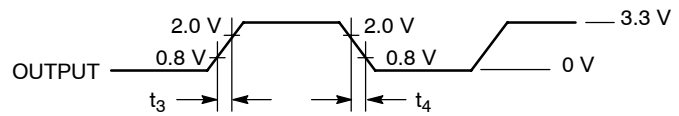

Figure 5. All Outputs Rise/Fall Time

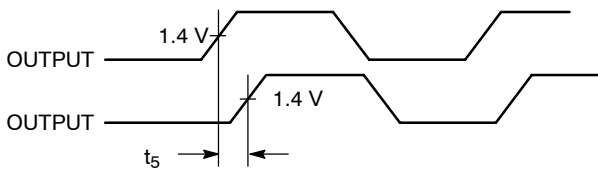

Figure 6. Output - Output Skew

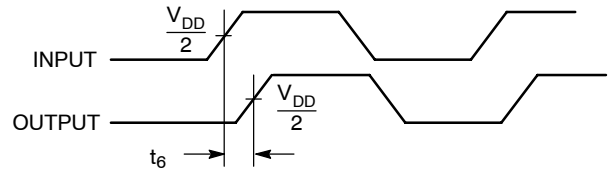

Figure 7. Input - Output Propagation Delay

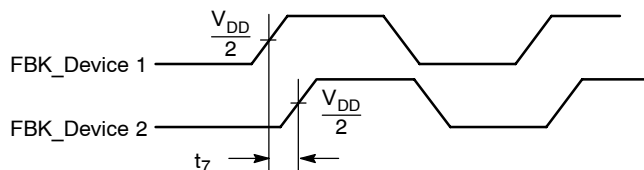

Figure 8. Device - Device Skew

NB2308A

TEST CIRCUITS

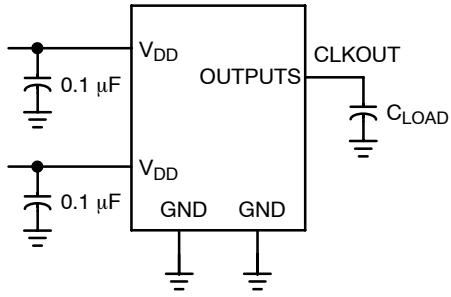

Figure 9. Test Circuit #1

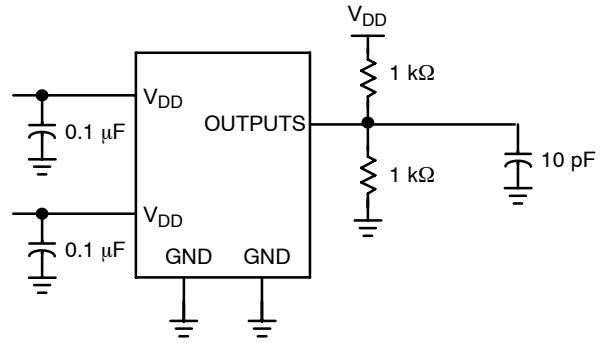

Figure 10. Test Circuit #2
For parameter t_b (output slew rate) on -1H devices

BLOCK DIAGRAMS

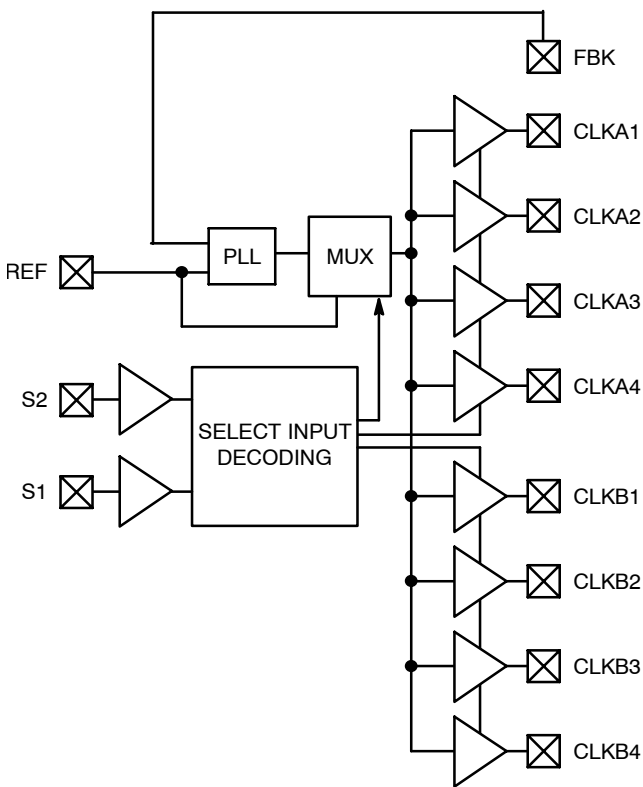

Figure 11. NB2308Ax1 and NB2308Ax1H

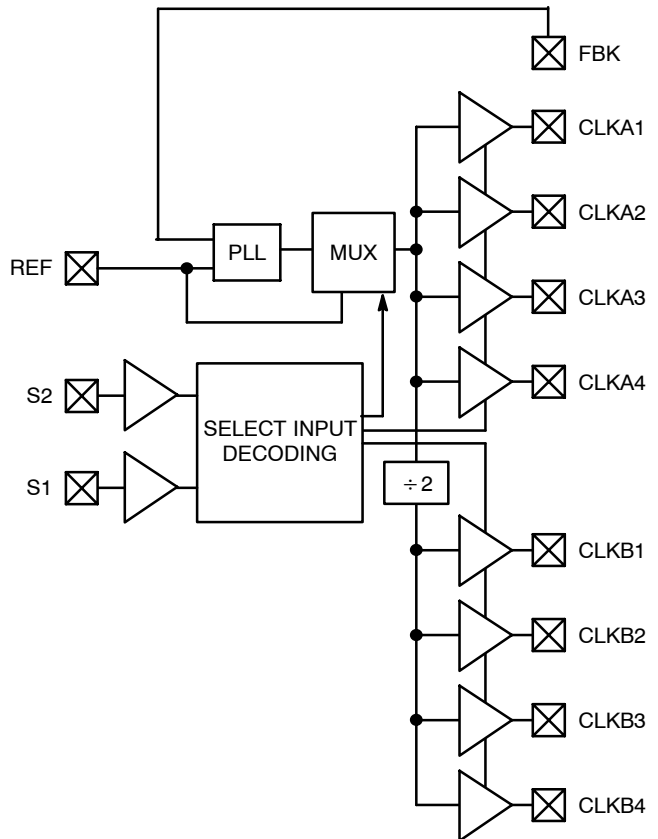

Figure 12. NB2308Ax2

NB2308A

BLOCK DIAGRAMS

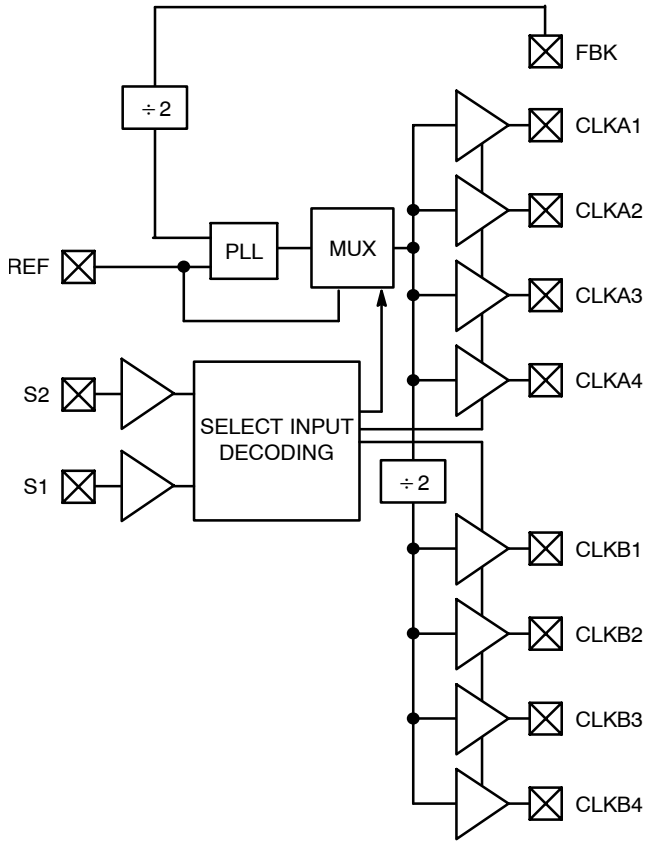

Figure 13. NB2308Ax3

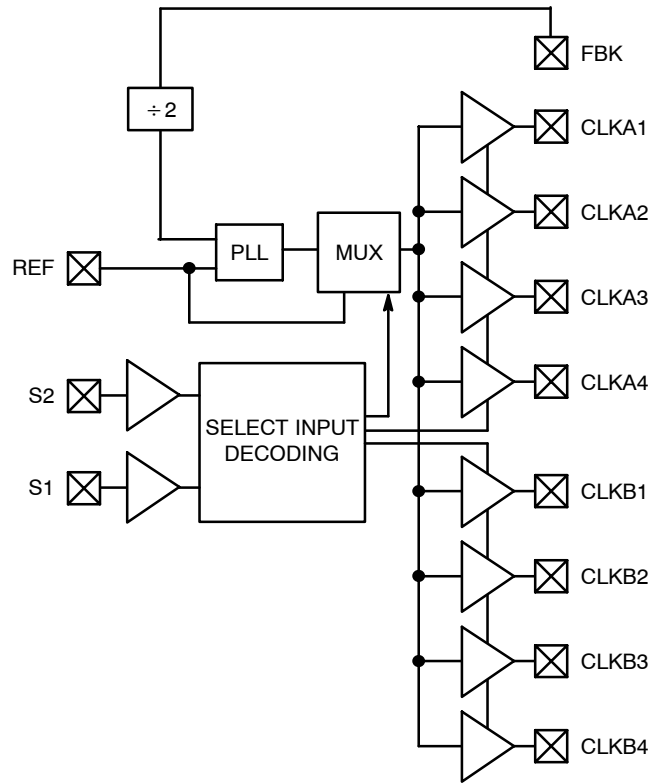

Figure 14. NB2308Ax4

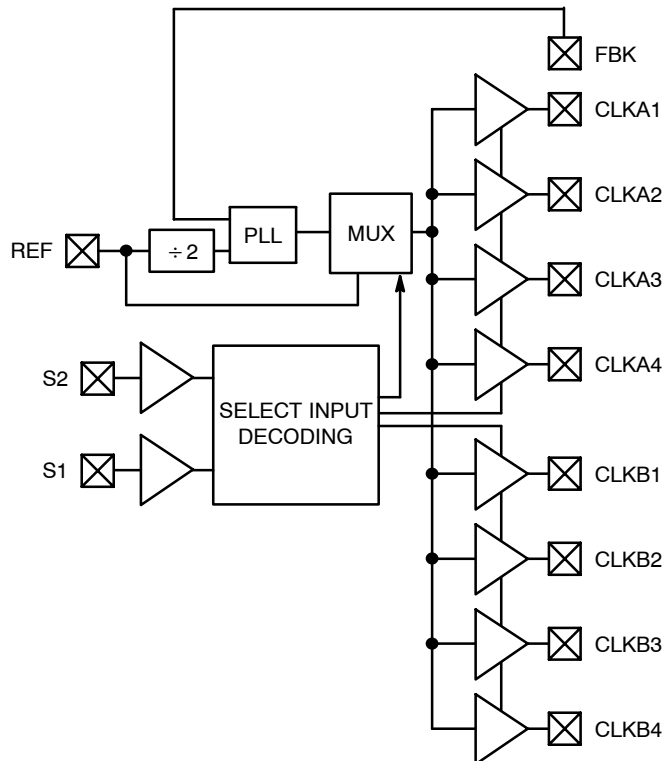

Figure 15. NB2308Ax5H

NB2308A

ORDERING INFORMATION

Device	Marking	Operating Range	Package	Shipping [†]	Availability
NB2308AC1D	2308AC1	Commercial	SOIC-16	48 Units / Rail	Now
NB2308AC1DG	2308AC1G	Commercial	SOIC-16 (Pb-Free)	48 Units / Rail	Now
NB2308AC1DR2	2308AC1	Commercial	SOIC-16	2500 Tape & Reel	Now
NB2308AC1DR2G	2308AC1G	Commercial	SOIC-16 (Pb-Free)	2500 Tape & Reel	Now
NB2308AI1D	2308AI1	Industrial	SOIC-16	48 Units / Rail	Now
NB2308AI1DG	2308AI1G	Industrial	SOIC-16 (Pb-Free)	48 Units / Rail	Now
NB2308AI1DR2	2308AI1	Industrial	SOIC-16	2500 Tape & Reel	Now
NB2308AI1DR2G	2308AI1G	Industrial	SOIC-16 (Pb-Free)	2500 Tape & Reel	Now
NB2308AC1HD	2308AC1H	Commercial	SOIC-16	48 Units / Rail	Now
NB2308AC1HDG	2308AC1HG	Commercial	SOIC-16 (Pb-Free)	48 Units / Rail	Now
NB2308AC1HDR2	2308AC1H	Commercial	SOIC-16	2500 Tape & Reel	Now
NB2308AC1HDR2G	2308AC1HG	Commercial	SOIC-16 (Pb-Free)	2500 Tape & Reel	Now
NB2308AI1HD	2308AI1H	Industrial	SOIC-16	48 Units / Rail	Now
NB2308AI1HDG	2308AI1HG	Industrial	SOIC-16 (Pb-Free)	48 Units / Rail	Now
NB2308AI1HDR2	2308AI1H	Industrial	SOIC-16	2500 Tape & Reel	Now
NB2308AI1HDR2G	2308AI1HG	Industrial	SOIC-16 (Pb-Free)	2500 Tape & Reel	Now
NB2308AC1DT	2308AC1	Commercial	TSSOP-16	96 Units / Rail	Now
NB2308AC1DTG	2308AC1	Commercial	TSSOP-16 (Pb-Free)	96 Units / Rail	Now
NB2308AC1DTR2	2308AC1	Commercial	TSSOP-16	2500 Tape & Reel	Now
NB2308AC1DTR2G	2308AC1	Commercial	TSSOP-16 (Pb-Free)	2500 Tape & Reel	Now
NB2308AI1DT	2308AI1	Industrial	TSSOP-16	96 Units / Rail	Now
NB2308AI1DTG	2308AI1	Industrial	TSSOP-16 (Pb-Free)	96 Units / Rail	Now
NB2308AI1DTR2	2308AI1	Industrial	TSSOP-16	2500 Tape & Reel	Now
NB2308AI1DTR2G	2308AI1	Industrial	TSSOP-16 (Pb-Free)	2500 Tape & Reel	Now
NB2308AC1HDT	2308AI1H	Commercial	TSSOP-16	96 Units / Rail	Now
NB2308AC1HDTG	2308AI1H	Commercial	TSSOP-16 (Pb-Free)	96 Units / Rail	Now
NB2308AC1HDTR2	2308AI1H	Commercial	TSSOP-16	2500 Tape & Reel	Now
NB2308AC1HDTR2G	2308AI1H	Commercial	TSSOP-16 (Pb-Free)	2500 Tape & Reel	Now
NB2308AI1HDT	2308AI1H	Industrial	TSSOP-16	96 Units / Rail	Now
NB2308AI1HDTG	2308AI1H	Industrial	TSSOP-16 (Pb-Free)	96 Units / Rail	Now
NB2308AI1HDTR2	2308AI1H	Industrial	TSSOP-16	2500 Tape & Reel	Now
NB2308AI1HDTR2G	2308AI1H	Industrial	TSSOP-16 (Pb-Free)	2500 Tape & Reel	Now

[†]For information on tape and reel specifications, including part orientation and tape sizes, please refer to our Tape and Reel Packaging Specifications Brochure, BRD8011/D.

NB2308A

ORDERING INFORMATION

Device	Marking	Operating Range	Package	Shipping [†]	Availability
NB2308AC2D	2308AC2	Commercial	SOIC-16	48 Units / Rail	Now
NB2308AC2DG	2308AC2G	Commercial	SOIC-16 (Pb-Free)	48 Units / Rail	Now
NB2308AC2DR2	2308AC2	Commercial	SOIC-16	2500 Tape & Reel	Now
NB2308AC2DR2G	2308AC2G	Commercial	SOIC-16 (Pb-Free)	2500 Tape & Reel	Now
NB2308AI2D	2308AI2	Industrial	SOIC-16	48 Units / Rail	Now
NB2308AI2DG	2308AI2G	Industrial	SOIC-16 (Pb-Free)	48 Units / Rail	Now
NB2308AI2DR2	2308AI2	Industrial	SOIC-16	2500 Tape & Reel	Now
NB2308AI2DR2G	2308AI2G	Industrial	SOIC-16 (Pb-Free)	2500 Tape & Reel	Now
NB2308AC2DT	2308AC2	Commercial	TSSOP-16	96 Units / Rail	Now
NB2308AC2DTG	2308AC2	Commercial	TSSOP-16 (Pb-Free)	96 Units / Rail	Now
NB2308AC2DTR2	2308AC2	Commercial	TSSOP-16	2500 Tape & Reel	Now
NB2308AC2DTR2G	2308AC2	Commercial	TSSOP-16 (Pb-Free)	2500 Tape & Reel	Now
NB2308AI2DT	2308AI2	Industrial	TSSOP-16	96 Units / Rail	Now
NB2308AI2DTG	2308AI2	Industrial	TSSOP-16 (Pb-Free)	96 Units / Rail	Now
NB2308AI2DTR2	2308AI2	Industrial	TSSOP-16	2500 Tape & Reel	Now
NB2308AI2DTR2G	2308AI2	Industrial	TSSOP-16 (Pb-Free)	2500 Tape & Reel	Now
NB2308AC3D	2308AC3	Commercial	SOIC-16	48 Units / Rail	Now
NB2308AC3DG	2308AC3G	Commercial	SOIC-16 (Pb-Free)	48 Units / Rail	Now
NB2308AC3DR2	2308AC3	Commercial	SOIC-16	2500 Tape & Reel	Now
NB2308AC3DR2G	2308AC3G	Commercial	SOIC-16 (Pb-Free)	2500 Tape & Reel	Now
NB2308AI3D	2308AI3	Industrial	SOIC-16	48 Units / Rail	Now
NB2308AI3DG	2308AI3G	Industrial	SOIC-16 (Pb-Free)	48 Units / Rail	Now
NB2308AI3DR2	2308AI3	Industrial	SOIC-16	2500 Tape & Reel	Now
NB2308AI3DR2G	2308AI3G	Industrial	SOIC-16 (Pb-Free)	2500 Tape & Reel	Now
NB2308AC3DT	2308AC3	Commercial	TSSOP-16	96 Units / Rail	Now
NB2308AC3DTG	2308AC3	Commercial	TSSOP-16 (Pb-Free)	96 Units / Rail	Now
NB2308AC3DTR2	2308AC3	Commercial	TSSOP-16	2500 Tape & Reel	Now
NB2308AC3DTR2G	2308AC3	Commercial	TSSOP-16 (Pb-Free)	2500 Tape & Reel	Now
NB2308AI3DT	2308AI3	Industrial	TSSOP-16	96 Units / Rail	Now
NB2308AI3DTG	2308AI3	Industrial	TSSOP-16 (Pb-Free)	96 Units / Rail	Now
NB2308AI3DTR2	2308AI3	Industrial	TSSOP-16	2500 Tape & Reel	Now
NB2308AI3DTR2G	2308AI3	Industrial	TSSOP-16 (Pb-Free)	2500 Tape & Reel	Now

[†]For information on tape and reel specifications, including part orientation and tape sizes, please refer to our Tape and Reel Packaging Specifications Brochure, BRD8011/D.

NB2308A

ORDERING INFORMATION

Device	Marking	Operating Range	Package	Shipping [†]	Availability
NB2308AC4D	2308AC4	Commercial	SOIC-16	48 Units / Rail	Now
NB2308AC4DG	2308AC4G	Commercial	SOIC-16 (Pb-Free)	48 Units / Rail	Now
NB2308AC4DR2	2308AC4	Commercial	SOIC-16	2500 Tape & Reel	Now
NB2308AC4DR2G	2308AC4G	Commercial	SOIC-16 (Pb-Free)	2500 Tape & Reel	Now
NB2308AI4D	2308AI4	Industrial	SOIC-16	48 Units / Rail	Now
NB2308AI4DG	2308AI4G	Industrial	SOIC-16 (Pb-Free)	48 Units / Rail	Now
NB2308AI4DR2	2308AI4	Industrial	SOIC-16	2500 Tape & Reel	Now
NB2308AI4DR2G	2308AI4G	Industrial	SOIC-16 (Pb-Free)	2500 Tape & Reel	Now
NB2308AC4DT	2308AC4	Commercial	TSSOP-16	96 Units / Rail	Now
NB2308AC4DTG	2308AC4	Commercial	TSSOP-16 (Pb-Free)	96 Units / Rail	Now
NB2308AC4DTR2	2308AC4	Commercial	TSSOP-16	2500 Tape & Reel	Now
NB2308AC4DTR2G	2308AC4	Commercial	TSSOP-16 (Pb-Free)	2500 Tape & Reel	Now
NB2308AI4DT	2308AI4	Industrial	TSSOP-16	96 Units / Rail	Now
NB2308AI4DTG	2308AI4	Industrial	TSSOP-16 (Pb-Free)	96 Units / Rail	Now
NB2308AI4DTR2	2308AI4	Industrial	TSSOP-16	2500 Tape & Reel	Now
NB2308AI4DTR2G	2308AI4	Industrial	TSSOP-16 (Pb-Free)	2500 Tape & Reel	Now
NB2308AC5HD	2308AC5H	Commercial	SOIC-16	48 Units / Rail	Now
NB2308AC5HDG	2308AC5HG	Commercial	SOIC-16 (Pb-Free)	48 Units / Rail	Now
NB2308AC5HDR2	2308AC5H	Commercial	SOIC-16	2500 Tape & Reel	Now
NB2308AC5HDR2G	2308AC5HG	Commercial	SOIC-16 (Pb-Free)	2500 Tape & Reel	Now
NB2308AI5HD	2308AI5H	Industrial	SOIC-16	48 Units / Rail	Now
NB2308AI5HDG	2308AI5HG	Industrial	SOIC-16 (Pb-Free)	48 Units / Rail	Now
NB2308AI5HDR2	2308AI5H	Industrial	SOIC-16	2500 Tape & Reel	Now
NB2308AI5HDR2G	2308AI5HG	Industrial	SOIC-16 (Pb-Free)	2500 Tape & Reel	Now
NB2308AC5HDT	2308AC5H	Commercial	TSSOP-16	96 Units / Rail	Now
NB2308AC5HDTG	2308AC5H	Commercial	TSSOP-16 (Pb-Free)	96 Units / Rail	Now
NB2308AC5HDTR2	2308AC5H	Commercial	TSSOP-16	2500 Tape & Reel	Now
NB2308AC5HDTR2G	2308AC5H	Commercial	TSSOP-16 (Pb-Free)	2500 Tape & Reel	Now
NB2308AI5HDT	2308AI5H	Industrial	TSSOP-16	96 Units / Rail	Now
NB2308AI5HDTG	2308AI5H	Industrial	TSSOP-16 (Pb-Free)	96 Units / Rail	Now
NB2308AI5HDTR2	2308AI5H	Industrial	TSSOP-16	2500 Tape & Reel	Now
NB2308AI5HDTR2G	2308AI5H	Industrial	TSSOP-16 (Pb-Free)	2500 Tape & Reel	Now

[†]For information on tape and reel specifications, including part orientation and tape sizes, please refer to our Tape and Reel Packaging Specifications Brochure, BRD8011/D.

NB2308A

PACKAGE DIMENSIONS

TSSOP-16
CASE 948F-01
ISSUE A

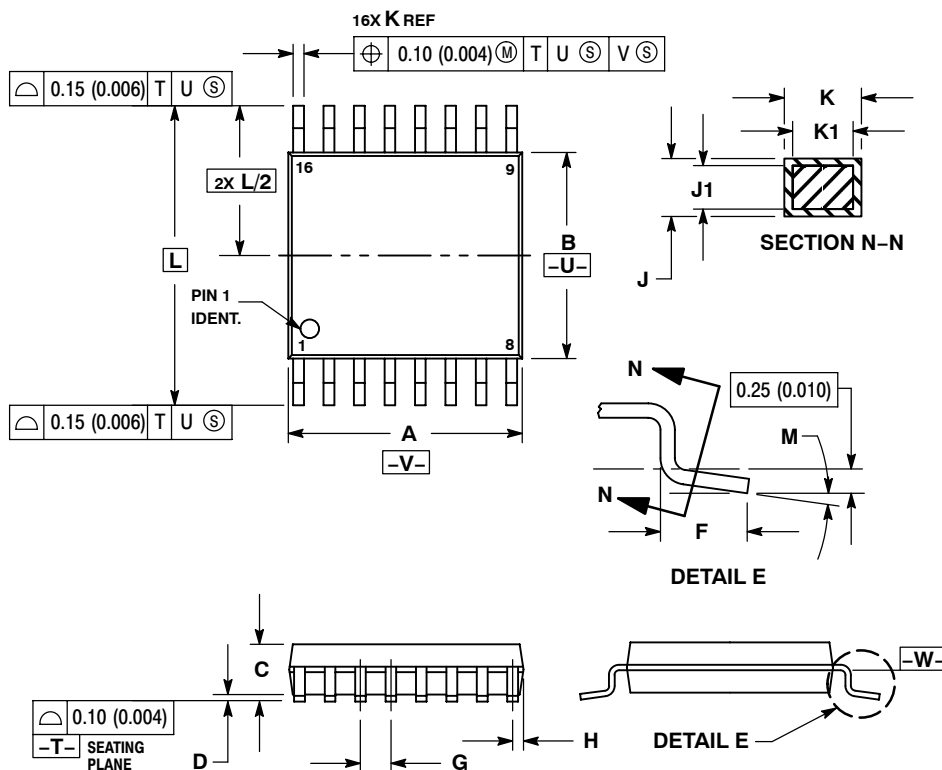

NOTES:

1. DIMENSIONING AND TOLERANCING PER ANSI Y14.5M, 1982.
2. CONTROLLING DIMENSION: MILLIMETER.
3. DIMENSION A DOES NOT INCLUDE MOLD FLASH, PROTRUSIONS OR GATE BURRS. MOLD FLASH OR GATE BURRS SHALL NOT EXCEED 0.15 (0.006) PER SIDE.
4. DIMENSION B DOES NOT INCLUDE INTERLEAD FLASH OR PROTRUSION. INTERLEAD FLASH OR PROTRUSION SHALL NOT EXCEED 0.25 (0.010) PER SIDE.
5. DIMENSION K DOES NOT INCLUDE DAMBAR PROTRUSION. ALLOWABLE DAMBAR PROTRUSION SHALL BE 0.08 (0.003) TOTAL IN EXCESS OF THE K DIMENSION AT MAXIMUM MATERIAL CONDITION.
6. TERMINAL NUMBERS ARE SHOWN FOR REFERENCE ONLY.
7. DIMENSION A AND B ARE TO BE DETERMINED AT DATUM PLANE *-W-*.

DIM	MILLIMETERS		INCHES	
	MIN	MAX	MIN	MAX
A	4.90	5.10	0.193	0.200
B	4.30	4.50	0.169	0.177
C	---	1.20	---	0.047
D	0.05	0.15	0.002	0.006
F	0.50	0.75	0.020	0.030
G	0.65 BSC		0.026 BSC	
H	0.18	0.28	0.007	0.011
J	0.09	0.20	0.004	0.008
J1	0.09	0.16	0.004	0.006
K	0.19	0.30	0.007	0.012
K1	0.19	0.25	0.007	0.010
L	6.40 BSC		0.252 BSC	
M	0°	8°	0°	8°

NB2308A

PACKAGE DIMENSIONS

SOIC-16
CASE 751B-05
ISSUE J

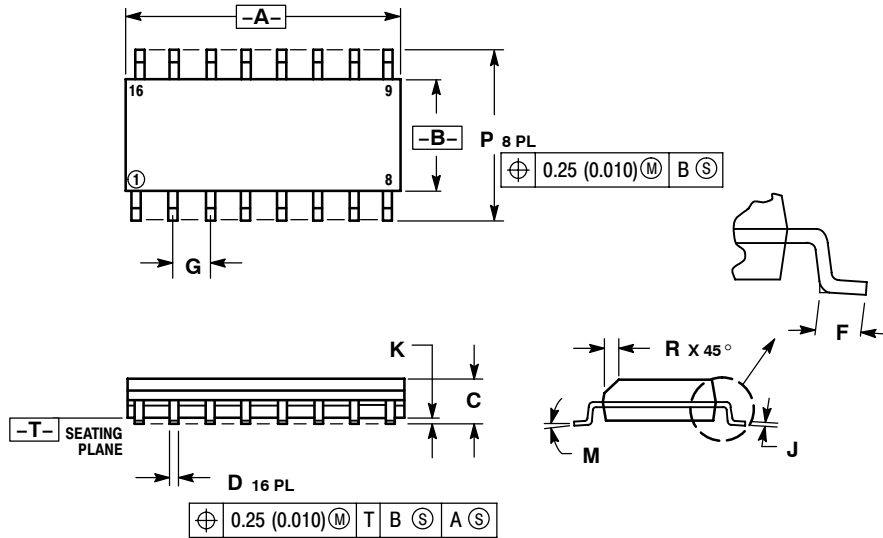

NOTES:

1. DIMENSIONING AND TOLERANCING PER ANSI Y14.5M, 1982.
2. CONTROLLING DIMENSION: MILLIMETER.
3. DIMENSIONS A AND B DO NOT INCLUDE MOLD PROTRUSION.
4. MAXIMUM MOLD PROTRUSION 0.15 (0.006) PER SIDE.
5. DIMENSION D DOES NOT INCLUDE DAMBAR PROTRUSION. ALLOWABLE DAMBAR PROTRUSION SHALL BE 0.127 (0.005) TOTAL IN EXCESS OF THE D DIMENSION AT MAXIMUM MATERIAL CONDITION.

DIM	MILLIMETERS		INCHES	
	MIN	MAX	MIN	MAX
A	9.80	10.00	0.386	0.393
B	3.80	4.00	0.150	0.157
C	1.35	1.75	0.054	0.068
D	0.35	0.49	0.014	0.019
F	0.40	1.25	0.016	0.049
G	1.27 BSC		0.050 BSC	
J	0.19	0.25	0.008	0.009
K	0.10	0.25	0.004	0.009
M	0° - 7°		0° - 7°	
P	5.80	6.20	0.229	0.244
R	0.25	0.50	0.010	0.019

Licensed under US patent Nos 5,488,627, 6,646,463 and 5,631,920.

ON Semiconductor and are registered trademarks of Semiconductor Components Industries, LLC (SCILLC). SCILLC reserves the right to make changes without further notice to any products herein. SCILLC makes no warranty, representation or guarantee regarding the suitability of its products for any particular purpose, nor does SCILLC assume any liability arising out of the application or use of any product or circuit, and specifically disclaims any and all liability, including without limitation special, consequential or incidental damages. "Typical" parameters which may be provided in SCILLC data sheets and/or specifications can and do vary in different applications and actual performance may vary over time. All operating parameters, including "Typicals" must be validated for each customer application by customer's technical experts. SCILLC does not convey any license under its patent rights nor the rights of others. SCILLC products are not designed, intended, or authorized for use as components in systems intended for surgical implant into the body, or other applications intended to support or sustain life, or for any other application in which the failure of the SCILLC product could create a situation where personal injury or death may occur. Should Buyer purchase or use SCILLC products for any such unintended or unauthorized application, Buyer shall indemnify and hold SCILLC and its officers, employees, subsidiaries, affiliates, and distributors harmless against all claims, costs, damages, and expenses, and reasonable attorney fees arising out of, directly or indirectly, any claim of personal injury or death associated with such unintended or unauthorized use, even if such claim alleges that SCILLC was negligent regarding the design or manufacture of the part. SCILLC is an Equal Opportunity/Affirmative Action Employer. This literature is subject to all applicable copyright laws and is not for resale in any manner.

PUBLICATION ORDERING INFORMATION

LITERATURE FULFILLMENT:
 Literature Distribution Center for ON Semiconductor
 P.O. Box 61312, Phoenix, Arizona 85082-1312 USA
Phone: 480-829-7710 or 800-344-3860 Toll Free USA/Canada
Fax: 480-829-7709 or 800-344-3867 Toll Free USA/Canada
Email: orderlit@onsemi.com

N. American Technical Support: 800-282-9855 Toll Free
 USA/Canada

Japan: ON Semiconductor, Japan Customer Focus Center
 2-9-1 Kamimeguro, Meguro-ku, Tokyo, Japan 153-0051
Phone: 81-3-5773-3850

ON Semiconductor Website: <http://onsemi.com>

Order Literature: <http://www.onsemi.com/litorder>

For additional information, please contact your local Sales Representative.

Looking for pricing, stock, or lifecycle information?

Click below to explore more details on WIN SOURCE:

 [View NB2308AI1HDT on WIN SOURCE](#)

 [ON Semiconductor](#) Information

Optimize Your Supply Chain with WIN SOURCE Solutions

-  Global Sourcing Solution
-  Obsolete Management
-  Cost Control Management
-  Shortage Management
-  Alternative Solution
-  Excess Inventory Management