



**THE DATASHEET OF
NCP5212AGEVB**



NCP5212A, NCP5212T

Single Synchronous Step-Down Controller

The NCP5212A/NCP5212T is a synchronous stepdown controller for high performance systems battery-power systems. The NCP5212A/NCP5212T includes a high efficiency PWM controller. A pin is provided to allow two devices in interleaved operation. An internal power good voltage monitor tracks the SMPS output. NCP5212A/NCP5212T also features soft-start sequence, UVLO for V_{CC} and switcher, overvoltage protection, overcurrent protection, undervoltage protection and thermal shutdown. The IC is packaged in QFN16

Features

- 0.8% accuracy 0.8 V Reference
- 4.5 V to 27 V Battery/Adaptor Voltage Range
- Adjustable Output Voltage Range: 0.8 V to 3.3 V
- Synchronization Interleaving between Two NCP5212A/NCP5212Ts
- Skip Mode for Power Saving Operation at Light Load
- Lossless Inductor Current Sensing
- Programmable Transient-Response-Enhancement (TRE) Control
- Programmable Adaptive Voltage Positioning (AVP)
- Input Supply Feedforward Control
- Internal Soft-Start
- Integrated Output Discharge (Soft-Stop)
- Build-in Adaptive Gate Drivers
- PGOOD Indication
- Overvoltage, Undervoltage and Overcurrent Protections
- Thermal Shutdown
- QFN16 Package
- These Devices are Pb-Free and are RoHS Compliant

Typical Applications

- Notebook Application
- System Power



ON Semiconductor®

<http://onsemi.com>

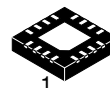

QFN16
CASE 485AP

MARKING DIAGRAMS

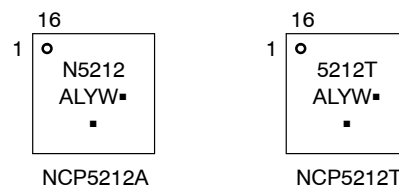

N5212/5212T Device Code
A = Assembly Location
L = Wafer Lot
Y = Year
W = Work Week
▪ = Pb-Free Package

(Note: Microdot may be in either location)

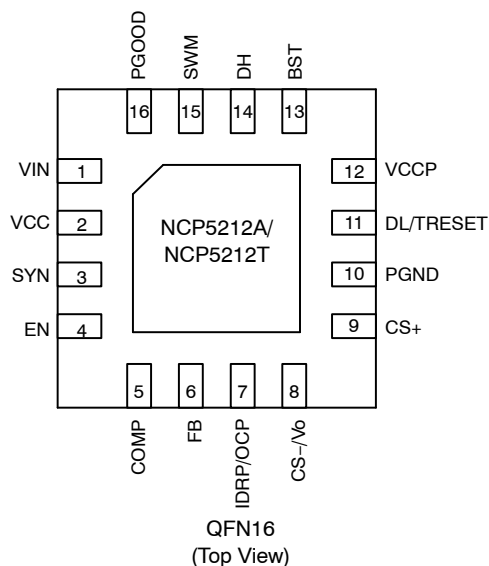

ORDERING INFORMATION

See detailed ordering and shipping information in the package dimensions section on page 18 of this data sheet.

NCP5212A, NCP5212T

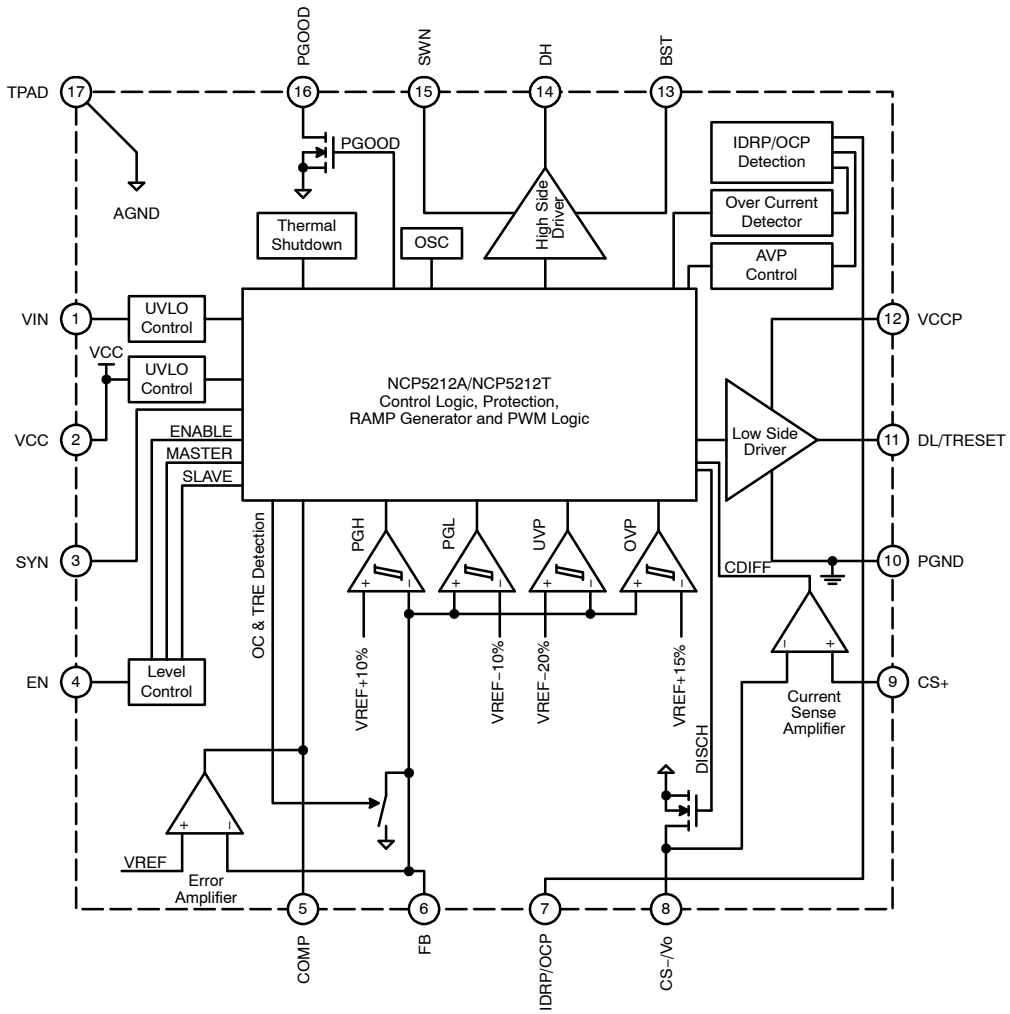

Figure 1. Detail Block Diagram

NCP5212A, NCP5212T

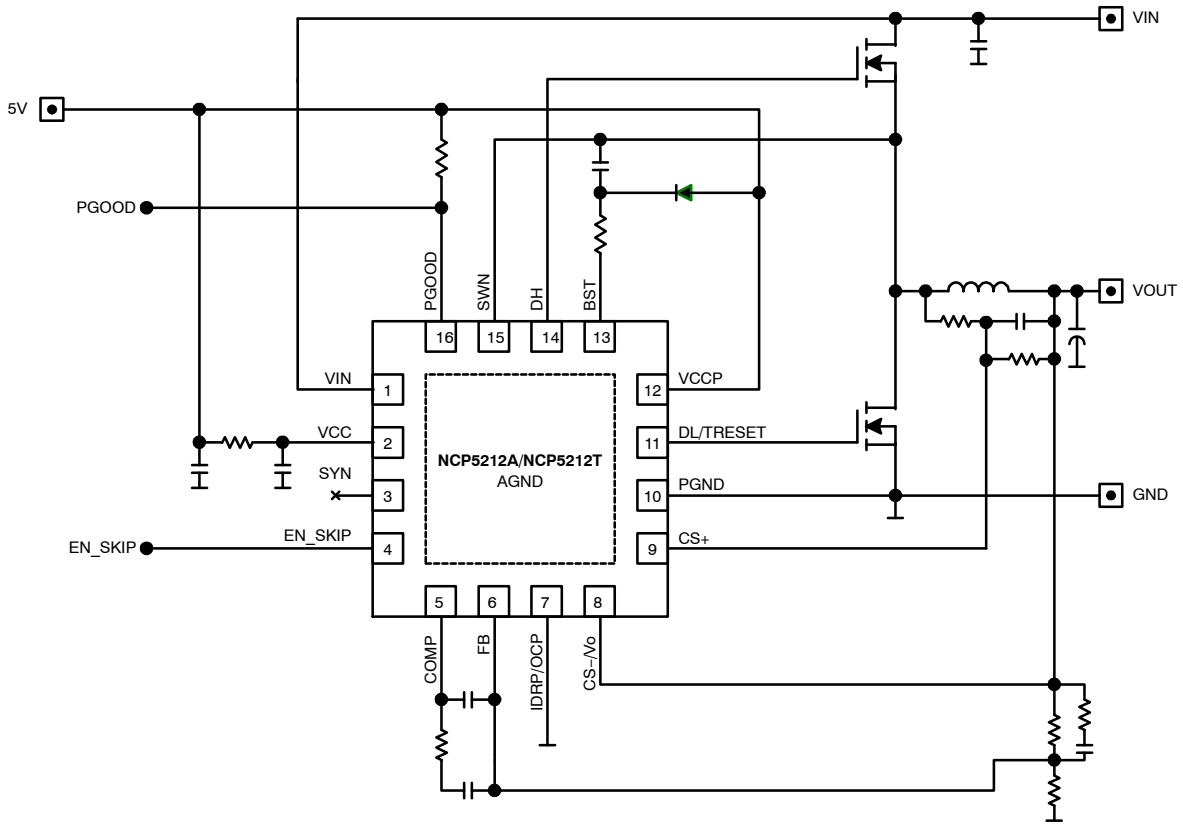

Figure 2. Typical Application Circuit (Single Device Operation)

NCP5212A, NCP5212T

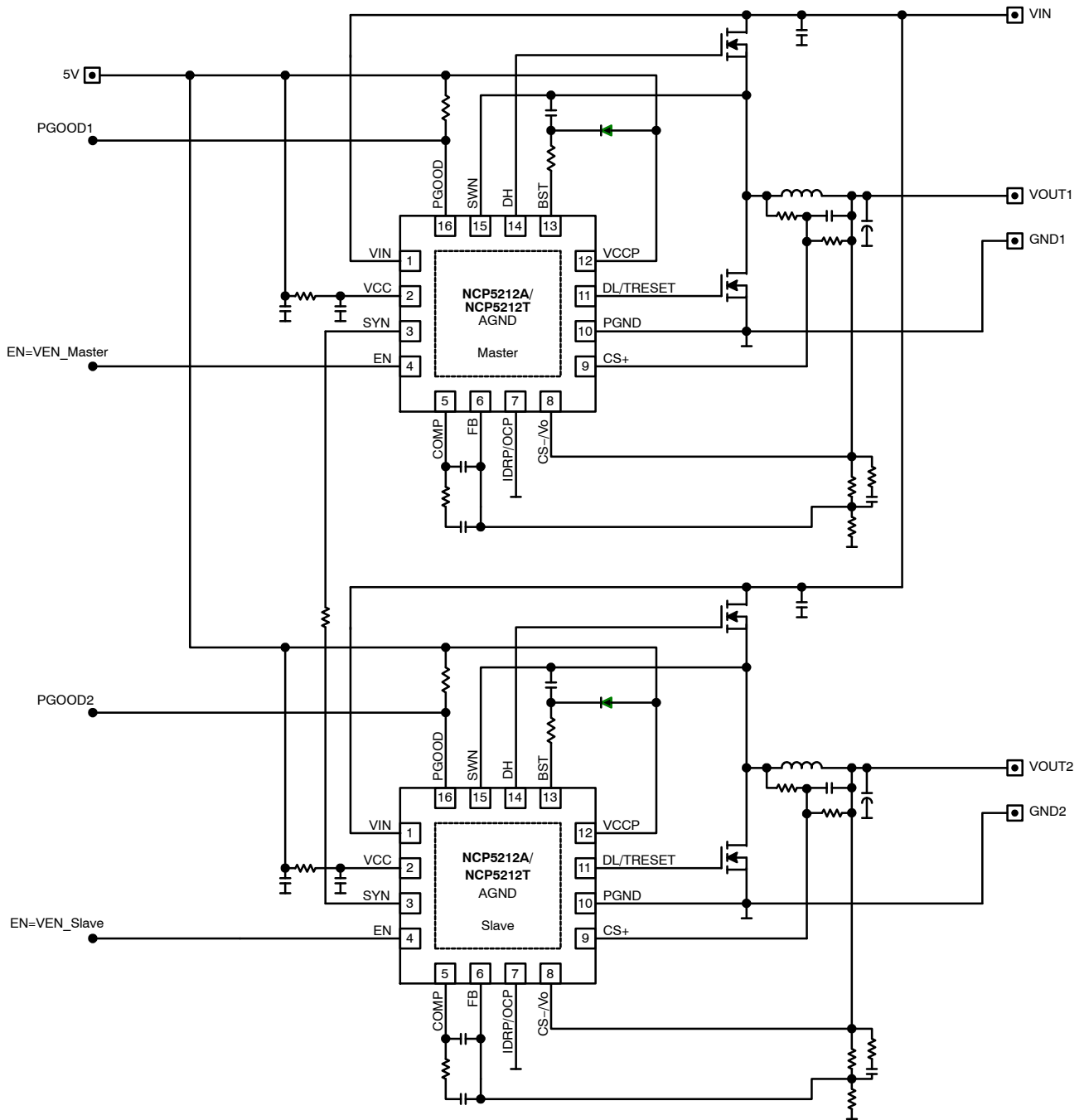

Figure 3. Typical Application Circuit (Dual Device Operation)

NCP5212A, NCP5212T

PIN FUNCTION DESCRIPTION

Pin No.	Symbol	Description
1	VIN	Input voltage used for feed forward in switcher operation.
2	VCC	Supply for analog circuit
3	SYN	Synchronization interleaving use.
4	EN	This pin serves as two functions. Enable: Logic control for enabling the switcher. MASTER/SLAVE: To program the device as MASTER or SLAVE mode at dual device operation.
5	COMP	Output of the error amplifier.
6	FB	Output voltage feed back.
7	IDRP/OCP	Current limit programmable and setting for AVP.
8	CS-/Vo	Inductor current differential sense inverting input.
9	CS+	Inductor current differential sense non-inverting input.
10	PGND	Ground reference and high-current return path for the bottom gate driver.
11	DL/TRESET	Gate driver output of bottom N-channel MOSFET. It also has the function for TRE threshold setting.
12	VCCP	Supply for bottom gate driver.
13	BST	Top gate driver input supply, a bootstrap capacitor connection between SWN and this pin.
14	DH	Gate driver output of top N-channel MOSFET.
15	SWN	Switch node between top MOSFET and bottom MOSFET.
16	PGOOD	Power good indicator of the output voltage. High impedance if power good (in regulation). Low impedance if power not good.
17	TPAD	Copper pad on bottom of IC used for heat sinking. This pin should be connected to the analog ground plane under the IC.

ABSOLUTE MAXIMUM RATINGS

Rating	Symbol	Value	Unit
VCC Power Supply Voltage to AGND	V_{CC}	-0.3, 6.0	V
VIN Supply to AGND	V_{IN}	-0.3, 30	V
High-side Gate Drive Supply: BST to SWN High-side Gate Drive Voltage: DH to SWN Low-side Gate Drive Supply: VCCP to PGND Low-side Gate Drive Voltage: DL to PGND	$V_{BST-V_{SWN}}$, $V_{DH-V_{SWN}}$, $V_{CCP-V_{PGND}}$, $V_{DL-V_{PGND}}$	-0.3, 6.0	V
Input / Output Pins to AGND	V_{IO}	-0.3, 6.0	V
Switch Node SWN-PGND	V_{SWN}	-5 V (< 100 ns) 30 V	V
High-Side Gate Drive/Low-Side Gate Drive Outputs	DH, DL	-3(DC)	V
PGND	V_{PGND}	-0.3, 0.3	V
Thermal Characteristics Thermal Resistance Junction-to-Ambient (QFN16 Package)	$R_{\theta JA}$	48	°C/W
Operating Junction Temperature Range (Note 1)	T_J	-40 to +150	°C
Operating Ambient Temperature Range	T_A	-40 to +85	°C
Storage Temperature Range	T_{stg}	-55 to +150	°C
Moisture Sensitivity Level	MSL	1	-

Stresses exceeding Maximum Ratings may damage the device. Maximum Ratings are stress ratings only. Functional operation above the Recommended Operating Conditions is not implied. Extended exposure to stresses above the Recommended Operating Conditions may affect device reliability.

NOTE: This device is ESD sensitive. Use standard ESD precautions when handling.

1. Internally limited by thermal shutdown, 150°C min.

NCP5212A, NCP5212T

ELECTRICAL CHARACTERISTICS ($V_{IN} = 12\text{ V}$, $V_{CC} = V_{CCP} = 5\text{ V}$, $T_A = -40^\circ\text{C}$ to 85°C , unless other noted)

Characteristics	Symbol	Test Conditions	Min	Typ	Max	Unit
-----------------	--------	-----------------	-----	-----	-----	------

SUPPLY VOLTAGE

Input Voltage	V_{IN}		4.5	–	27	V
V_{CC} Operating Voltage	V_{CC}		4.5	5.0	5.5	V

SUPPLY CURRENT

V_{CC} Quiescent Supply Current in Master operation	IVCC_Master	EN = VEN_Master, V_{FB} forced above regulation point. DH, DL are open		1.5	2.5	mA
V_{CC} Quiescent Supply Current in Slave Operation	IVCC_Slave	EN = VEN_Slave, V_{FB} forced above regulation point, DH, DL are open		1.5	2.5	mA
V_{CC} Shutdown Current	IVCC_SD	EN = VEN_Disable, $V_{CC} = 5\text{ V}$, True Shutdown			1	μA
BST Quiescent Supply Current in Master Operation	IBST_Master	EN = VEN_Master, V_{FB} forced above regulation point, DH and DL are open, No boost trap diode			0.3	mA
BST Quiescent Supply Current in Slave Operation	IBST_Slave	EN = VEN_Slave, V_{FB} forced above regulation point, DH and DL are open, No boost trap diode			0.3	mA
BST Shutdown Current	IBST_SD	EN = 0 V			1	μA
VCCP Shutdown Current	IVCCP_SD	EN = 0 V, $V_{CCP} = 5\text{ V}$			1	μA
V_{IN} Supply Current	IVIN	EN = 5V, $V_{IN} = 27\text{ V}$			35	μA
V_{IN} Shutdown Current	IVIN_SD	EN = 0 V, $V_{IN} = 27\text{ V}$			1	μA

VOLTAGE-MONITOR

Rising VCC Threshold	VCcTh+	Wake Up		4.05	4.25	4.48	V
VCC UVLO Hysteresis	VCcHYS			200	275	400	mV
Rising VIN Threshold	VINth+	Wake Up, Design Spec. (Note 2)		3.4	3.8	4.2	V
VIN UVLO Hysteresis	VINHYS	(Note 2)		200	500	800	mV
Power Good High Threshold	VPGH	PGOOD in from higher V_o (PGOOD goes high)	NCP5212A	105	110	115	%
			NCP5212T	120	125	130	
Power Good High Hysteresis	VPGH_HYS	PGOOD high hysteresis (PGOOD goes low)			5		%
Power Good Low Threshold	VPGL	PGOOD in from lower V_o (PGOOD goes high)		80	85	90	%
Power Good Low Hysteresis	VPGL_HYS	PGOOD low hysteresis (PGOOD goes low)			–5		%
Power Good High Delay	Td_PGH	After Tss, (Note 2)			1.25		ms
Power Good Low Delay	Td_PGL	(Note 2)			1.5		μs
Output Overvoltage Rising Threshold	OVpTh+	With respect to Error Comparator Threshold of 0.8 V	NCP5212A	110	115	120	%
			NCP5212T	125	130	135	
Overvoltage Fault Propagation Delay	OVPTblk	FB forced 2% above trip threshold (Note 2)			1.5		μs
Output Undervoltage Trip Threshold	UVpTh	With respect to Error Comparator Threshold of 0.8 V		75	80	85	%
Output Undervoltage Protection Blanking Time	UVPTblk	(Note 2)		–	8/fsw	–	s

REFERENCE OUTPUT

Internal Reference Voltage	V_{ref}		0.7936	0.8	0.8064	V
----------------------------	-----------	--	--------	-----	--------	---

2. Guaranteed by design, not tested in production.

NCP5212A, NCP5212T

ELECTRICAL CHARACTERISTICS ($V_{IN} = 12\text{ V}$, $V_{CC} = V_{CCP} = 5\text{ V}$, $T_A = -40^\circ\text{C}$ to 85°C , unless other noted)

Characteristics	Symbol	Test Conditions	Min	Typ	Max	Unit
-----------------	--------	-----------------	-----	-----	-----	------

OSCILLATOR

Operation Frequency	F_{SW}		270	300	330	kHz
---------------------	----------	--	-----	-----	-----	-----

OVERCURRENT THRESHOLD

Total Detection Time	T_{DETECT}	Period of FB shorts to ground before SS	1.26	1.92	2.21	ms
OCSET Detection Time	T_{OCDET}	(Note 2)	1.09		1.47	ms

INTERNAL SOFT-START

Soft-Start Time	TSS		0.9	1.1	1.3	ms
-----------------	-----	--	-----	-----	-----	----

VOLTAGE ERROR AMPLIFIER

DC Gain	GAIN_VEA	(Note 2)		88		dB
Unity Gain Bandwidth	BW_VEA	(Note 2)		15		MHz
Slew Rate	SR_VEA	COMP PIN TO GND = 100 pF (Note 2)		2.5		V/ μ s
FB Bias Current	Ibias_FB				0.1	μ A
Output Voltage Swing	Vmax_EA	Isource_EA = 2 mA	3.3	3.5		V
	Vmin_EA	Isink_EA = 2 mA		0.15	0.3	V

DIFFERENTIAL CURRENT SENSE AMPLIFIER

CS+ and CS- Common-mode Input Signal Range	VCSCOM_MAX	Refer to AGND			3.5	V	
Input Bias Current	CS_IIB		-100		100	nA	
Input Signal Range	CS_range		-70		70	mV	
Offset Current at IDRP	IDRP_offset	(CS+) - (CS-) = 0 V	-1.0		1.0	μ A	
[(CS+) - (CS-)] to IDRP Gain	IDRP_GAIN (IDRP/((CS+) - (CS-)))	(CS+) - (CS-) = 10 mV, V(IDRP) = 0.8 V	$T_A = 25^\circ\text{C}$	0.475	0.525	0.575	μ A/mV
			$T_A = -40^\circ\text{C}$ to 85°C	0.425		0.625	μ A/mV
Current-Sense Bandwidth	BW_CS	At -3dB to DC Gain (Note 2)		20		MHz	
Maximum IDRP Output Voltage	IDRP_Max	(CS+) - (CS-) = 70 mV, Isource drops to 95% of the value when V(IDRP) = 0.8 V	2.5			V	
Minimum IDRP Output Voltage	IDRP_Min			0		V	
IDRP Output current	I_IDRP		-1.0		35	μ A	

OVERCURRENT PROTECTION SETTING

Overcurrent Threshold (OCTH) Detection Current	I_OCSET	Sourced from OCP before soft-start, Rocset = 16.7 k Ω is connected from OCP to AGND or FB	21.6	24	26.4	μ A
Ratio of OC Threshold over OCSET Voltage	K_OCSET	$V((CS+) - (CS-)) / V_{OCSET}$ (Note 2)		0.1		-
OCSET Voltage for Default Fixed OC Threshold	VOCSET_DFT	Rocset \leq 2 k Ω is connected from OCP to AGND or FB			100	mV
OCSET Voltage for Adjustable OC Threshold	VOCSET_ADJ	Rocset = 8.3 ~ 25 k Ω is connected from OCP to AGND or FB	200		600	mV
OCSET Voltage for OC Disable	VOCSET_DIS	Rocset \geq 35 k Ω is connected from OCP to AGND or FB	720			mV
Default Fixed OC Threshold	V_OCTH_DFT	(CS+) - (CS-), Pin OCP is shorted to AGND or FB	35	40	45	mV

2. Guaranteed by design, not tested in production.

NCP5212A, NCP5212T

ELECTRICAL CHARACTERISTICS ($V_{IN} = 12\text{ V}$, $V_{CC} = V_{CCP} = 5\text{ V}$, $T_A = -40^\circ\text{C}$ to 85°C , unless other noted)

Characteristics	Symbol	Test Conditions	Min	Typ	Max	Unit
-----------------	--------	-----------------	-----	-----	-----	------

OVERCURRENT PROTECTION SETTING

Adjustable OC Threshold	V_{OCTH} ((CS+)-(CS-))	(CS+) – (CS-), During OC threshold, set a voltage at pin OCP	VOCSET = 200 mV	15	20	25	mV
			VOCSET = 600 mV	52	60	68	

GATE DRIVERS

DH Pull-HIGH Resistance	RH_DH	200 mA Source current		1		Ω
DH Pull-LOW Resistance	RL_DH	200 mA Sink current		1		Ω
DL Pull-HIGH Resistance	RH_DL	200 mA Source current		1		Ω
DL Pull-LOW Resistance	RL_DL	200 mA Sink current		0.5		Ω
DH Source Current	Isource_DH	(Note 2)		2.5		A
DH Sink Current	Isink_DH	(Note 2)		2.5		A
DL Source Current	Isource_DL	(Note 2)		2.5		A
DL Sink Current	Isink_DL	(Note 2)		5		A
Dead Time	TD_LH	DL-off to DH-on (Note 2)		20		ns
	TD_HL	DH-off to DL-on (Note 2)		20		ns
Negative Current Detection Threshold	NCD_TH	SWN – PGND, at EN = 5 V		-1		mV
SWN source leakage	ISWN_SD	EN = 0 V, SWN = 0 V			1	μA
Internal Resistor from DH to SWN	R_DH_SWN	(Note 2)		100		k Ω

CONTROL SECTION

EN Logic Input Voltage for Disable	VEN_Disable	Set as Disable	0.7	1.0	1.3	V
		Hysteresis	150	200	250	mV
EN Logic Input Voltage for MASTER Mode	VEN_Master	Set as Master Mode	1.7	1.95	2.25	V
EN Logic Input Voltage for SLAVE Mode	VEN_Slave	Set as Slave Mode	2.4	2.65	2.9	V
		Hysteresis	100	175	250	mV
EN Source Current	IEN_SOURCE	VEN = 0 V			0.1	μA
EN Sink Current	IEN_SINK	VEN = 5 V			0.1	μA
PGOOD Pin ON Resistance	PGOOD_R	I_PGOOD = 5 mA		100		Ω
PGOOD Pin OFF Current	PGOOD_LK				1	μA

SYNC CONTROL

SYNC pin leakage	ISYNC_LK	Set as Slave Mode, SYNC = 5 V			1	μA
SYNC frequency	F_SYNC	(Note 2)		1.2		MHz
Pulse Width	PW_SYNC	(Note 2)		416		ns
Clock Level Low	V_CLKL	(Note 2)		0		V
Clock Level High	V_CLKH	(Note 2)		5		V
SYNC Driving Capability	SYNC_CL	Set as Master Mode, load capacitor between SYNC and GND (Note 2)			20	pF
SYNC Source Current	ISYNC	SYNC shorts to ground			20	mApp

OUTPUT DISCHARGE MODE

Output Discharge On-Resistance	Rdischarge	EN = 0 V		20	35	Ω
Threshold for Discharge Off	Vth_DisOff		0.2	0.3	0.4	V

2. Guaranteed by design, not tested in production.

NCP5212A, NCP5212T

ELECTRICAL CHARACTERISTICS ($V_{IN} = 12\text{ V}$, $V_{CC} = V_{CCP} = 5\text{ V}$, $T_A = -40^\circ\text{C}$ to 85°C , unless other noted)

Characteristics	Symbol	Test Conditions	Min	Typ	Max	Unit	
TRE SETTING							
TRE Threshold Detection Current	I_TRESET	Sourced from DL in the short period before soft-start. (Rtre = 47 kΩ is connected from DL to GND)	7.2	8	8.8	μA	
Detection Voltage for TRE Threshold Selection	VDL_TRE_1 (Default)	Internal TRE_TH is set to 300 mV	Rtre ≥ 75 kΩ (Note 2)	500	600	700	mV
	VDL_TRE_2	Internal TRE_TH is set to 500 mV	Rtre = 44 – 50 kΩ (Note 2)	300		450	
	VDL_TRE_3	TRE is Disabled	Rtre ≤ 25 kΩ (Note 2)	0		250	
TRE Comparator Offset	TRE_OS	(Note 2)		10		mV	
Propagation Delay of TRE Comparator	TD_PWM	(Note 2)		20		ns	

THERMAL SHUTDOWN

Thermal Shutdown	Tsd	(Note 2)		150		°C
Thermal Shutdown Hysteresis	Tsdhys	(Note 2)		25		°C

2. Guaranteed by design, not tested in production.

NCP5212A, NCP5212T

TYPICAL OPERATING CHARACTERISTICS

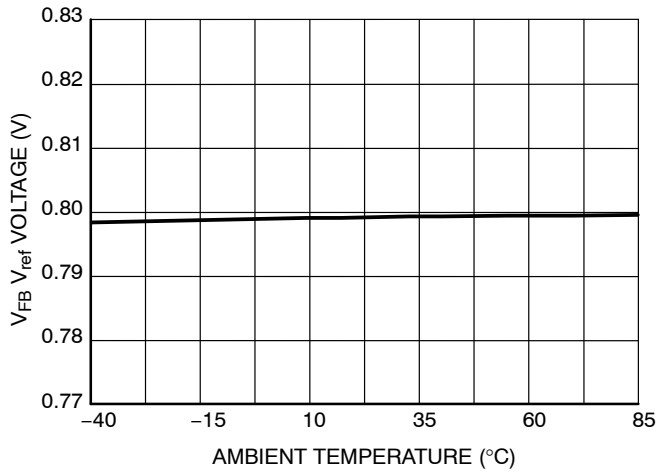

Figure 4. V_{ref} Voltage vs Ambient Temperature

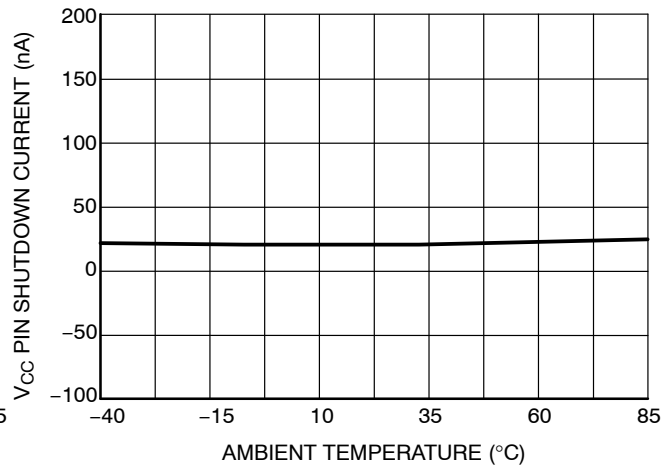

Figure 5. V_{CC} Shutdown Current vs Ambient Temperature

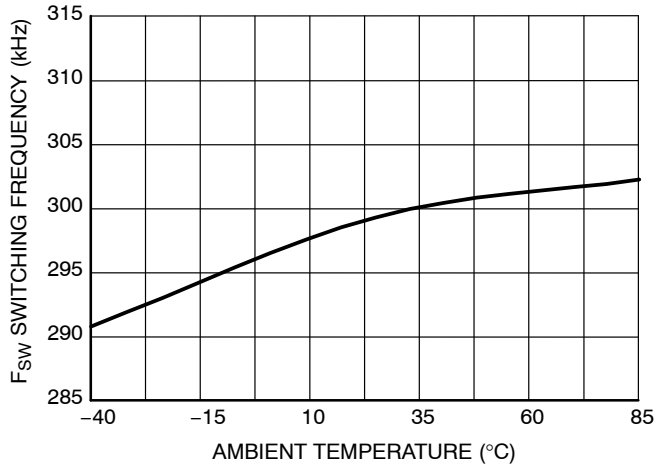

Figure 6. Switching Frequency vs Ambient Temperature

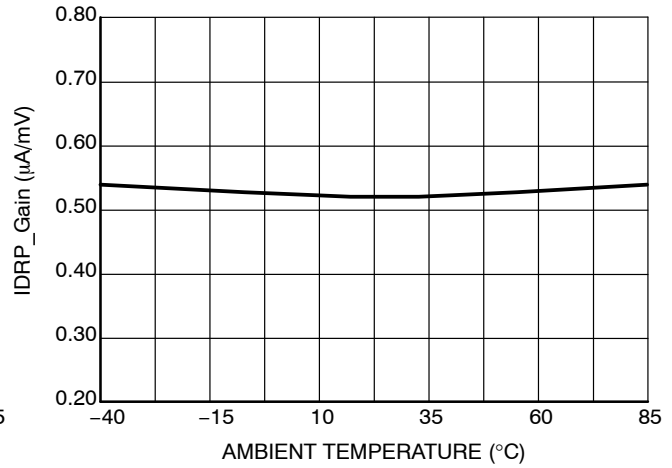

Figure 7. IDR Gain vs Ambient Temperature

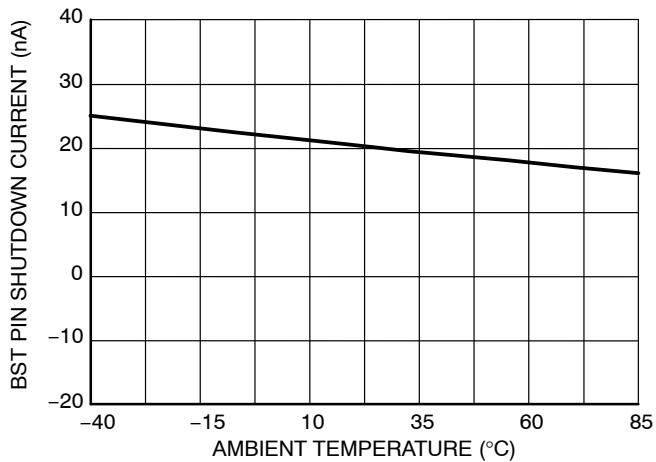

Figure 8. BST Shutdown Current vs Ambient Temperature

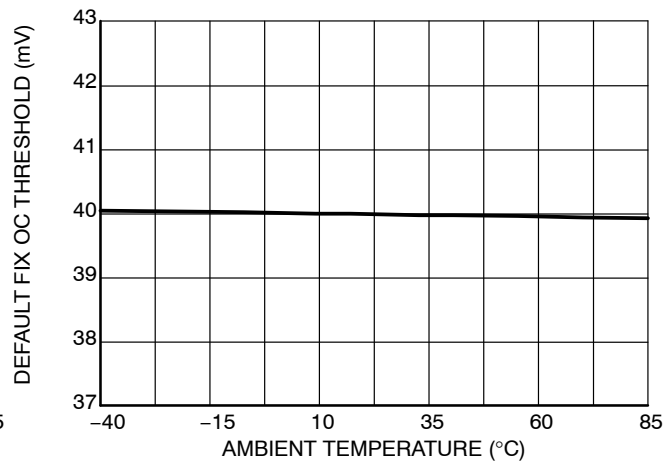
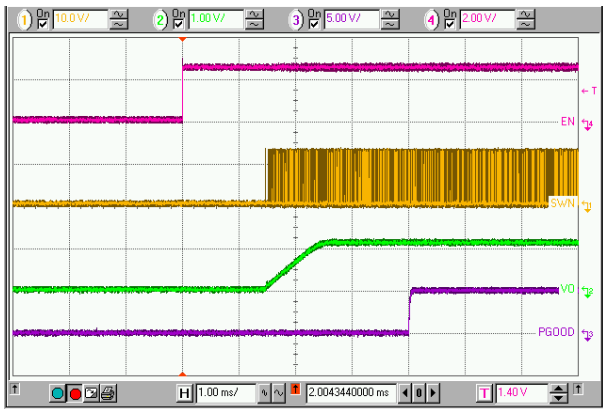

Figure 9. Default Fix OC Threshold vs Ambient Temperature

NCP5212A, NCP5212T

TYPICAL OPERATING CHARACTERISTICS



Top to Bottom: EN, SWN, Vo, PGOOD

Figure 10. Powerup Sequence

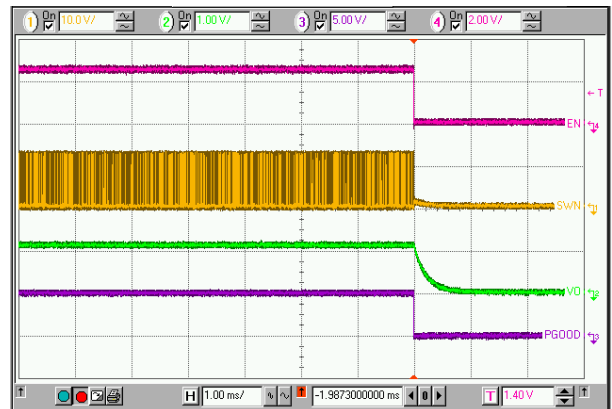

Top to Bottom: EN, SWN, Vo, PGOOD

Figure 11. Powerdown Sequence



Top to Bottom: SWN_Slave, Vo_Slave, SWN_Master, Sync_clk

Figure 12. From Unsync to Sync



Top to Bottom: SWN_Slave, Vo_Slave, SWN_Master, Sync_clk

Figure 13. From Sync to Unsync

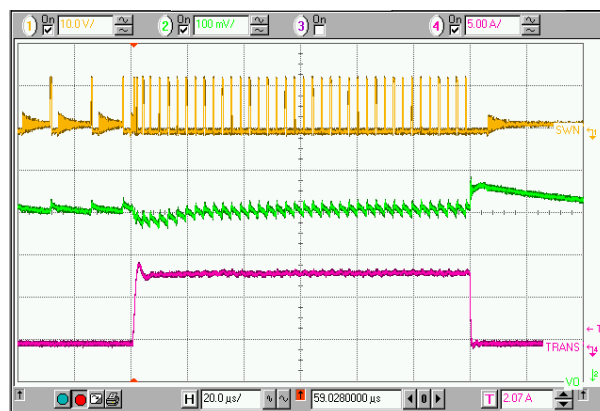

Top to Bottom: SWN, Vo, Io

Figure 14. Typical Transient

DETAILED OPERATING DESCRIPTION

General

The NCP5212A/NCP5212T synchronous stepdown power controller contains a PWM controller for wide battery/adaptor voltage range applications

The NCP5212A/NCP5212T includes power good voltage monitor, soft-start, overcurrent protection, undervoltage protection, overvoltage protection and thermal shutdown. The NCP5212A/NCP5212T features power saving function which can increase the efficiency at light load. It is ideal for battery operated systems. The IC is packaged in QFN16.

Control Logic

The internal control logic is powered by V_{CC} . The device is controlled by an EN pin. The EN pin serves two functions. When voltage of EN is below $V_{EN_Disable}$, it shuts down the device. When the voltage of EN is at the level of V_{EN_Master} , the device is operating as Master mode. When voltage level of EN is at V_{EN_Slave} , the device is operating as Slave mode. It should be noted that no matter the device is operating either at Master or Slave mode, the device is operating in the manner of auto power saving condition such that it operates as skip mode automatically at light load. When EN is above $V_{EN_Disable}$, the internal V_{ref} is activated and power-on reset occurs which resets all the protection faults. Once V_{ref} reaches its regulation voltage, an internal signal will wake up the supply undervoltage monitor which will assert a “GOOD” condition. In addition, the NCP5212A/NCP5212T continuously monitors V_{CC} and V_{IN} levels with undervoltage lockout (UVLO) function.

Single Device Operation

The device is operating as single device operation when the SYNC pin is pull to ground. Under this configuration, the device will use the internal clock for normal PWM operation.

Dual Device Operation (Master/Slave Mode)

The device is operating as Master/Slave mode if two devices are tied up together. (Detail configuration please see the application schematic) One device is served as Master and another one is served as Slave. Once they already, they are synchronized to each other and they are operating as “interleaved” mode such that the phase shift of their switching clocks is 180° . It has the benefit that the amount of ripple current at the V_{IN} will be lower and hence lesser bulk capacitors at V_{IN} to save the confined PCB space and material cost. Figure 15 and Figure 16 show the difference when the devices are operating independently (unsynchronized) and operating at interleaved mode (Synchronized). It can be seen that at the unsynchronized condition, the system is obviously noisy because of high ripple voltage at V_{IN} (ripple voltage directly reflects the amount of ripple current at V_{IN}). Once the devices are operating at interleaving mode, the overall V_{IN} ripple current is significantly reduced.

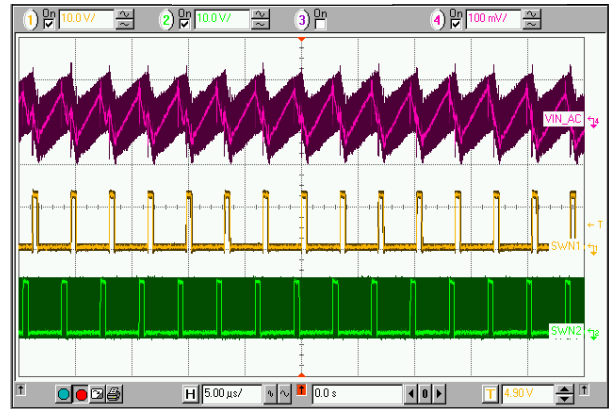

Top to Bottom: VIN AC Voltage, SWN_Slave, SWN_Master

Figure 15. Two Devices are Unsynchronized

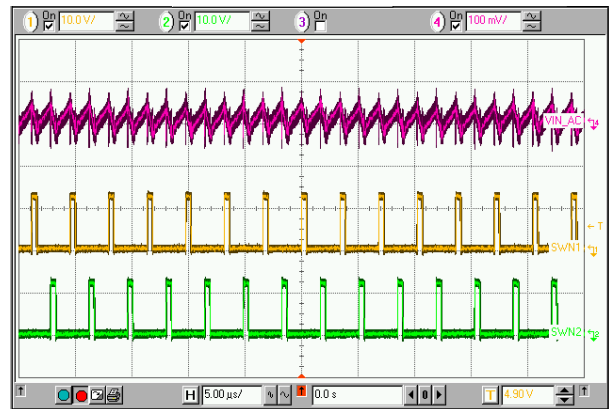

Top to Bottom: VIN AC Voltage, SWN_Slave, SWN_Master

Figure 16. Two Devices are in Interleaved Operation

Transient Response Enhancement (TRE)

For the conventional PWM controller in CCM, the fastest response time is one switching cycle in the worst case. To further improve transient response in CCM, a transient response enhancement circuitry is implemented inside the NCP5212A/NCP5212T. In CCM operation, the controller is continuously monitoring the COMP pin output voltage of the error amplifier to detect the load transient events. The functional block diagram of TRE is shown below.

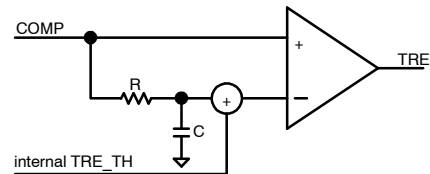
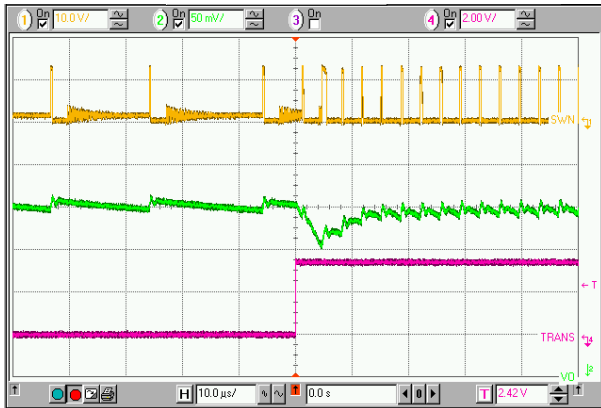

Figure 17. Block Diagram of TRE Circuit

Once the large transient occurs, the COMP signal may be large enough to exceed the threshold and then TRE “flag” signal will be asserted in a short period which is typically around one normal switching cycle. In this short period, the controller will be running at high frequency and hence has faster response. After that the controller comes back to normal switching frequency operation. We can program the internal TRE threshold (TRE_TH). For detail please see the electrical table of “TRE Setting” section. Basically, the recommend internal TRE threshold value is around 1.5 times of peak-to-peak value of the COMP signal at CCM operation. The higher the internal TRE_TH, the lower sensitivity to load transient. The TRE function can be disable by setting the Rtre which is connecting to DL/TRE pin to less than 25 kΩ. For system component saving, it is usually set as default value, that is, Rtre is open (≥ 75 kΩ) and internal TRE_TH is 300 mV typical.



Top to Bottom SWN, Vo, Transient Signal

Figure 18. Transient Response with TRE Disable

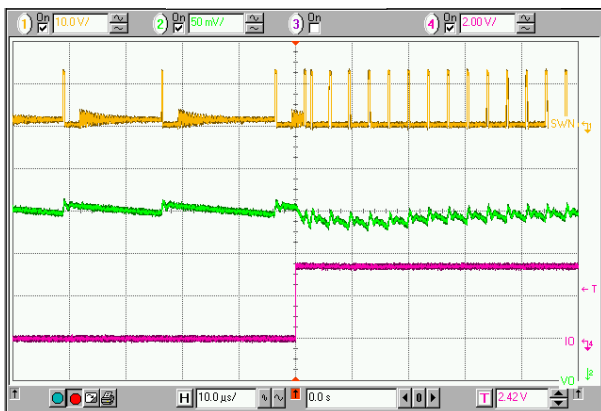

Top to Bottom SWN, Vo, Transient Signal

Figure 19. Transient Response with TRE Enable

Adaptive Voltage Positioning (AVP)

For applications with fast transient currents, adaptive voltage positioning can reduce peak-to-peak output voltage deviations due to load transients. With the use of AVP, the output voltage allows to have some controlled sag when load current is applied. Upon removal of the load, the output voltage returns no higher than the original level, just allowing one output transient peak to be cancelled over a load step up and release cycle. The amount of AVP is adjustable.

The behaviors of the V_o waveforms with or without AVP are depicted at Figure 20.

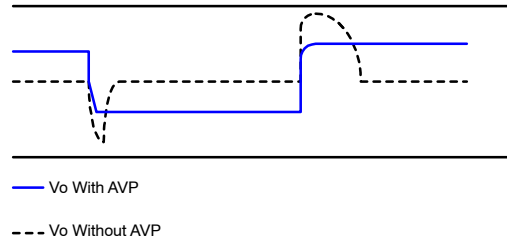

Figure 20. Adaptive Voltage Positioning

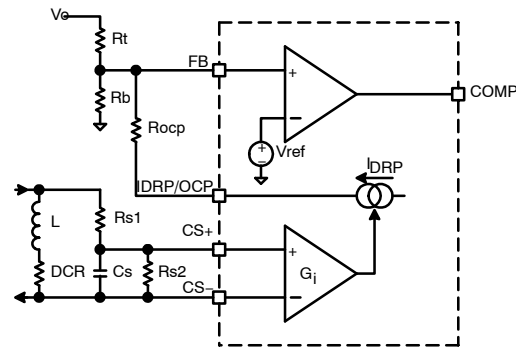

Figure 21. Configuration for AVP Function

The Figure 21 shows how to realize the AVP function. A current path is connecting to the FB pin via Rocp resistor. Rocp is not actually for AVP function, indeed, Rocp is used for OCP threshold value programming. The IDRPs/OCP pin has dual functions: OCP programming and AVP. At the IDRPs/OCP pin, conceptually there is a current source which is modulated by current sensing amplifier.

The output voltage V_o with AVP is:

$$V_o = V_{o0} - I_o * R_{LL} \tag{eq. 1}$$

Where I_o is the load current, no load output voltage V_{o0} is set by the external divider that is:

$$V_{o0} = \left(1 + \frac{R_t}{R_b} \right) * V_{ref} \tag{eq. 2}$$

NCP5212A, NCP5212T

The load line impedance R_{LL} is given by:

$$R_{LL} = DCR * Gain_CS * Rt * \frac{Rs2}{Rs1 + Rs2} \quad (\text{eq. 3})$$

Where DCR is inductor DC resistance. Gain_CS is a gain from [(CS+)-(CS-)] to IDRPs Gain (At electrical table, the symbol is IDRPs_GAIN), the typical value is 0.525 $\mu\text{A}/\text{mV}$.

The AVP function can be easily disabled by shorting the Rocp resistor into ground.

From the equation we can see that the value of “top” resistor R_t can affect the amount of R_{LL} , so it is recommended to define the amount of R_{LL} FIRST before defining the compensation component value. And if the user wants to fine tune the compensation network for optimizing the transient performance, it is NOT recommend to adjust the value of R_t . Otherwise, both transient performance and AVP amount will be affected. The following diagram shows the typical waveform of AVP. Note that the R_t typical value should be above 1 k Ω .

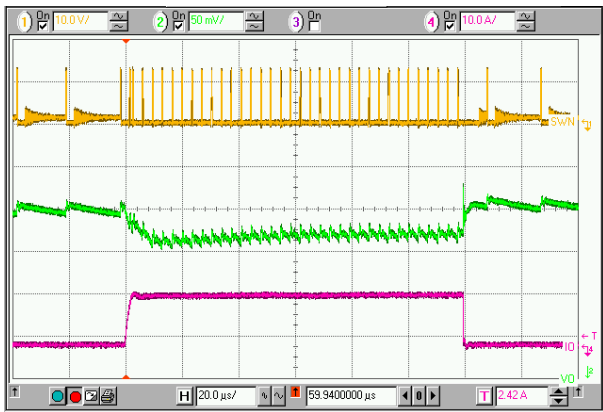

Top to Bottom: SWN, Vo, Transient Signal

Figure 22. Typical waveform of AVP

Over Current Protection (OCP)

The NCP5212A/NCP5212T protects power system if over current event occurs. The current is continuously monitored by the differential current sensing circuit. The current limit threshold voltage V_{OCSET} can be programmed by resistor R_{OCSET} connecting at the IDRPs/OCP pin. However, fixed default V_{OCSET} can be achieved if R_{OCSET} is less than 2 k Ω .

If the inductor current exceeds the current threshold continuously, the top gate driver will be turned off cycle by cycle. If it happens over consecutive 16 clock cycles time ($16 \times 1/f_{SW}$), the device is latched off such that top and bottom gate drivers are off. EN resets or power recycle the device can exit the fault. The following diagram shows the typical behavior of OCP.

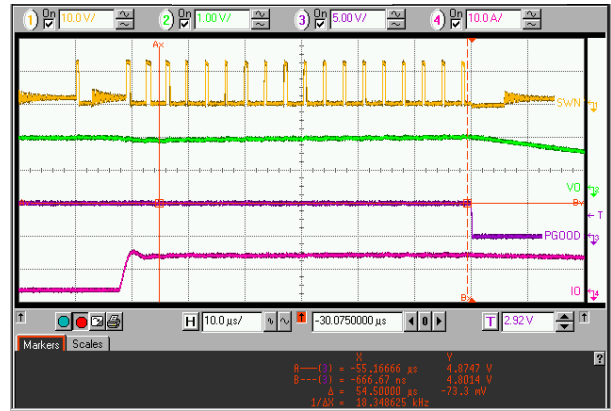

Top to Bottom : SWN, Vo, PGOOD, Io

Figure 23. Overcurrent Protection

The NCP5212A/NCP5212T uses lossless inductor current sensing for acquiring current information. In addition, the threshold OCP voltage can be programmed to some desired value by setting the programming resistor R_{ocp} .

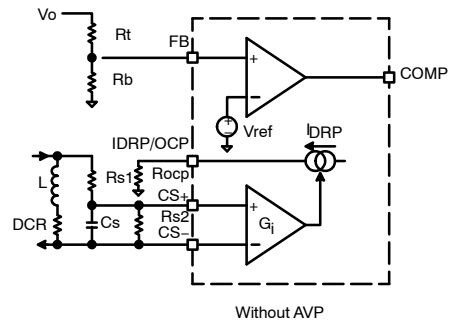

Without AVP

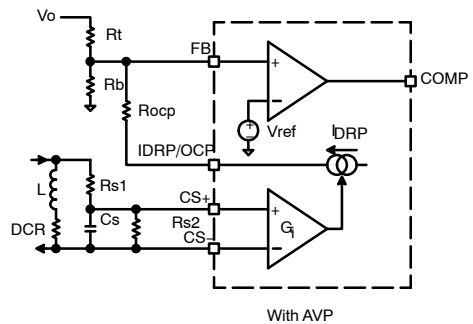

With AVP

Figure 24. OCP Configuration

It should be noted that there are two configurations for R_{ocp} resistor. If Adaptor Voltage Position (AVP) is used, the R_{ocp} should be connected to FB pin. If AVP is not used, the R_{ocp} should be connected to ground. At the IDRPs/OCP pin, there is a constant current (24 μA typ.) flowing out during the

programming stage at system start up. This is used to sense the voltage level which is developed by a resistor R_{ocp} so as to program the overcurrent detection threshold voltage. For typical application, the V_{octh} is set as default value(40 mV typ) by setting $R_{ocp} = 0 \Omega$, or directly short the IDR/P/OC pin to ground. It has the benefit of saving one component at application board. For other programming values of V_{octh} , please refer to the electrical table of “Overcurrent Protection Setting” section.

Guidelines for selecting OCP Trip Component

1. Choose the value of R_{ocp} for V_{octh} selection.
2. Define the DC value of OCP trip point(I_{OCP_DC}) that you want. The typical value is 1.5 to 1.8 times of maximum loading current. For example, if maximum loading is 10 A, then set OCP trip point at 15 A to 18 A.
3. Calculate the inductor peak current (I_{pk})which is estimated by the equation:

$$I_{pk} = I_{OCP_DC} + \frac{V_o * (V_{IN} - V_o)}{2 * V_{IN} * f_{SW} * L_o} \quad (eq. 4)$$

4. Check with inductor datasheet to find out the value of inductor DC resistance DCR, then calculate the RS1, RS2 dividing factor k based on the equation:

$$k = \frac{V_{octh}}{I_{pk} * DCR} \quad (eq. 5)$$

5. Select C_S value between 100 nF to 200 nF. Typically, 100 nF will be used.
6. Calculate Rs1 value by the equation:

$$Rs1 = \frac{L}{k * DCR * C_s} \quad (eq. 6)$$

7. Calculate Rs2 value by the equation:

$$Rs2 = \frac{k * Rs1}{1 - k} \quad (eq. 7)$$

8. Hence, all the current sense components Rs1, Rs2, Cs had been found for target I_{OCP_DC} .
9. If Rs2 is not used (open), set $k = 1$, at that moment, the I_{pk} will be restricted by:

$$I_{pk} = \frac{V_{octh}}{DCR} \quad (eq. 8)$$

Overvoltage Protection (OVP)

When V_{FB} voltage is above OVP_{th+} of the nominal V_{FB} voltage for over 1.5 μs blanking time, an OV fault is set. At that moment, the top gate drive is turned off and the bottom gate drive is turned on until the V_{FB} below lower under voltage (UV) threshold and bottom gate drive is turned on again whenever V_{FB} goes above upper UV threshold. EN

resets or power recycle the device can exit the fault. The following diagram shows the typical waveform when OVP event occurs.

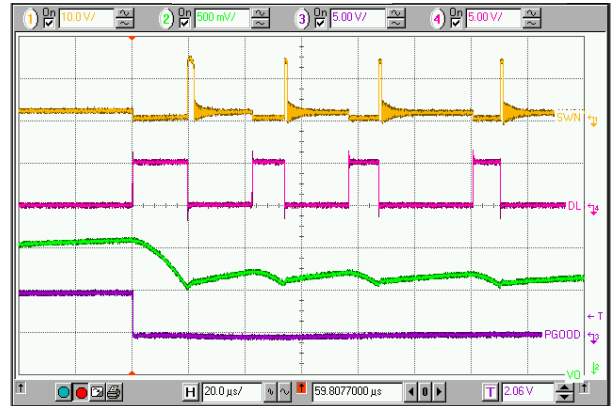

Top to Bottom : SWN, DL, Vo, PGOOD

Figure 25. Overvoltage Protection

Undervoltage Protection (UVP)

An UVP circuit monitors the V_{FB} voltage to detect under voltage event. The under voltage limit is 80% (typical) of the nominal V_{FB} voltage. If the V_{FB} voltage is below this threshold over consecutive 8 clock cycles, an UV fault is set and the device is latched off such that both top and bottom gate drives are off. EN resets or power recycle the device can exit the fault.

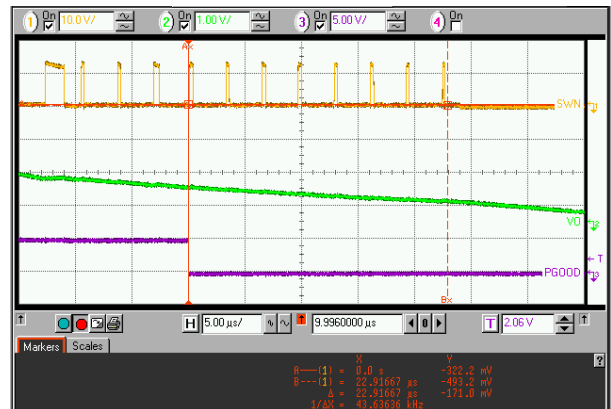

Top to Bottom : SWN, Vo, PGOOD

Figure 26. Undervoltage Protection

Thermal Shutdown

The IC will shutdown if the die temperature exceeds 150°C. The IC restarts operation only after the junction temperature drops below 125°C.

NCP5212A, NCP5212T

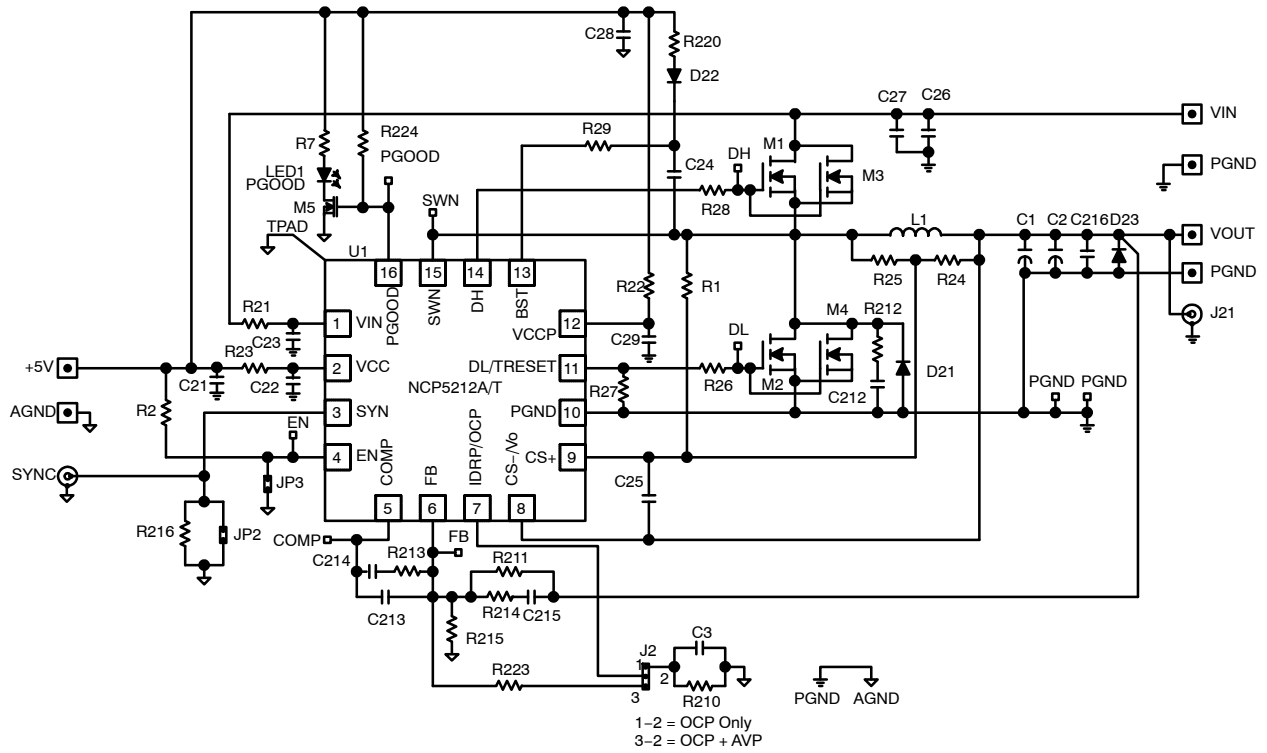

Figure 27. Demo Board Schematic

NCP5212A, NCP5212T

DEMO BOARD BILL OF MATERIAL BOM (See next tables for compensation network and power stage)

Designator	Qty	Description	Value	Footprint	Manufacturer	Manufacturer P/N
U1	1	Single Synchronous Stepdown Controller	-	QFN 16PIN	ON Semiconductor	NCP5212MNR2G
R1	1	Chip Resistor, $\pm 5\%$	DNP	-	-	-
R2	1	Chip Resistor, $\pm 5\%$	10k	0603	Panasonic	ERJ3GEYJ103V
R7	1	Chip Resistor, $\pm 5\%$	1k	0603	Panasonic	ERJ3GEYJ102V
R21	1	Chip Resistor, $\pm 5\%$	20	0603	Panasonic	ERJ3GEYJR200V
R22	1	Chip Resistor, $\pm 5\%$	0	0603	Panasonic	ERJ3GEYJR00V
R23	1	Chip Resistor, $\pm 5\%$	5.6	0603	Panasonic	ERJ3GEYJR5R6V
R26	1	Chip Resistor, $\pm 5\%$	0	0603	Panasonic	ERJ3GEYJR00V
R27	1	Chip Resistor, $\pm 5\%$	DNP	-	-	-
R28	1	Chip Resistor, $\pm 5\%$	0	0603	Panasonic	ERJ3GEYJR00V
R29	1	Chip Resistor, $\pm 5\%$	5.6	0603	Panasonic	ERJ3GEYJR5R6V
R210	1	Chip Resistor, $\pm 1\%$	1k	0603	Panasonic	ERJ3EKF1001V
R212	1	Chip Resistor	DNP	0603	Panasonic	ERJ3EKF2403V
R216	1	Chip Resistor, $\pm 5\%$	10k	0603	Panasonic	ERJ3GEYJ103V
R220	1	Chip Resistor, $\pm 5\%$	0	0603	Panasonic	ERJ3GEYJR00V
R223	1	Chip Resistor, $\pm 1\%$	1k	0603	Panasonic	ERJ3EKF1001V
R224	1	Chip Resistor, $\pm 5\%$	100k	0603	Panasonic	ERJ3GEYJ104V
C3	1	-	DNP	-	-	-
C21	1	MLCC Chip Capacitor, $\pm 20\%$ Temp Char: X5R, Rate V = 25 V,	1 μ F	0805	Panasonic	ECJ2FB1E105M
C22	1	MLCC Chip Capacitor, $\pm 20\%$ Temp Char: X5R, Rate V = 25 V	1 μ F	0805	Panasonic	ECJ2FB1E105M
C23	1	MLCC Chip Capacitor, $\pm 10\%$ Temp Char: X7R, Rate V = 50 V	15 nF	0805	Panasonic	ECJ1VB1E153K
C24	1	MLCC Chip Capacitor, $\pm 10\%$ Temp Char: X7R, Rate V = 50 V	100 nF	0603	Panasonic	ECJ1VB1E104K
C25	1	MLCC Chip Capacitor Temp Char: X7R, $\pm 10\%$ Rate V = 50 V	100 nF	0603	Panasonic	ECJ1VB1E104K
C26	1	MLCC Chip Capacitor Temp Char: X5R, $\pm 20\%$ Rate V = 25 V	10 μ F	1206	Panasonic	ECJ3YB1E106M
C27	1	MLCC Chip Capacitor Temp Char: X5R, $\pm 20\%$ Rate V = 25 V	10 μ F	1206	Panasonic	ECJ3YB1E106M
C28	1	MLCC Chip Capacitor Temp Char: X5R, $\pm 20\%$ Rate V = 25 V	10 μ F	1206	Panasonic	ECJ3YB1E106M
C29	1	MLCC Chip Capacitor Temp Char: X5R, $\pm 20\%$ Rate V = 25 V	1 μ F	1206	Panasonic	ECJ3YB1E105M
C212	1	-	DNP	-	-	-
C216	1	MLCC Chip Capacitor Temp Char: X5R, $\pm 20\%$ Rate V = 25 V	1 μ F	0805	Panasonic	ECJ2FB1E105M
M5	1	Power MOSFET 50 V, 200 mA Single N-Ch	-	SOT-23	ON Semiconductor	BSS138L
D21	1	-	DNP	-	-	-
D22	1	30 V Schottky Diode Vf = 0.35 V @ 10 mA	-	SOT-23	ON Semiconductor	BAT54LT1
D23	1	-	DNP	-	-	-
SYNC, J21	2	SMB SMT Straight Socket	-	5.1 x 5.1 mm	Tyco Electronics	RS Stock# 420-5401
JP2, JP3, J2, EN, FB, COMP, DH, DL, SWN, PGOOD, PGND, PGND	12	Pin Header Single Row	-	Pitch = 2.54 mm	Betamax	2211S-40G-F1
LED1	1	Surface Mount LED Color = Green	-	0805	LUMEX	SML-LX0805GC-TR
+5V, AGND, GND, VOUT, VIN, PGND	1	Terminal Pin	-	f = 1.74 mm	HARWIN	H2121-01

NCP5212A, NCP5212T

DEMO BOARD BILL OF MATERIAL ($V_o = 1.1\text{ V}$, $I_o = 18\text{ A}$)

Item	Component	Value	Tol	Footprint	Manufacturer	Manufacturer P/N
Compensation Network	R211	3k	1%	0603	Panasonic	ERJ3EKF3001V
	R213	68k	1%	0603	Panasonic	ERJ3EKF6802V
	R214	300	1%	0603	Panasonic	ERJ3EKF3000V
	R215	8k	1%	0603	Panasonic	ERJ3EKF8001V
	C213	24 pF	10%	0603	Panasonic	ECJ1VC1H241K
	C214	470 pF	10%	0603	Panasonic	ECJ1VB1H471K
	C215	820 pF	10%	0603	Panasonic	ECJ1VB1H821K
Power Stage & Current Sense	M1, M3	-	-	SOIC8-FL	ON Semiconductor	NTMFS4821N
	M2, M4	-	-	SOIC8-FL	ON Semiconductor	NTMFS4847N
	L1	0.56 μH	20%	10x11.5 mm	Cyntec	PCMC104T-R56MN
	R24	DNP	-	-	-	-
	R25	4k	1%	0603	Panasonic	ERJ3EKF4301V
	C1, C2, C2A*	330 μF 6 m Ω	20%	7343	Panasonic	EEFSX0D331XR
					Sanyo	2TPLF330M6

*C2A is the capacitor soldered right beside of C2.

DEMO BOARD BILL OF MATERIAL ($V_o = 1.5\text{ V}$, $I_o = 8\text{ A}$)

Item	Component	Value	Tol	Footprint	Manufacturer	Manufacturer P/N
Compensation Network	R211	5k	1%	0603	Panasonic	ERJ3EKF5001V
	R213	75k	1%	0603	Panasonic	ERJ3EKF7502V
	R214	1k	1%	0603	Panasonic	ERJ3EKF1001V
	R215	5.6k	1%	0603	Panasonic	ERJ3EKF5601V
	C213	9 pF	10%	0603	Panasonic	ECJ1VC1H900K
	C214	270 pF	10%	0603	Panasonic	ECJ1VB1H271K
	C215	330 pF	10%	0603	Panasonic	ECJ1VB1H331K
Power Stage & Current Sense	M1, M2	-	-	SO8	ON Semiconductor	NTMS4705N
	M3, M4	DNP	-	-	-	-
	L1	1 μH	20%	10x11.5 mm	Cyntec	PCMC104T-1R0MN
				13x14x4.9mm	WE	744315120
	R24	DNP	-	-	-	-
	R25	4.3k	1%	0603	Panasonic	ERJ3EKF4301V
	C1, C2	220 μF 12 m Ω	20%	7343	Panasonic	EEFUD0D221XR
Sanyo					2R5TPL220MC	

ORDERING INFORMATION

Device	Package	Shipping [†]
NCP5212AMNTXG	QFN16 (Pb-Free)	3000 / Tape & Reel
NCP5212TMNTXG	QFN16 (Pb-Free)	3000 / Tape & Reel

[†]For information on tape and reel specifications, including part orientation and tape sizes, please refer to our Tape and Reel Packaging Specifications Brochure, BRD8011/D.

NCP5212A, NCP5212T

PACKAGE DIMENSIONS

QFN16 4x4, 0.65P
CASE 485AP-01
ISSUE A

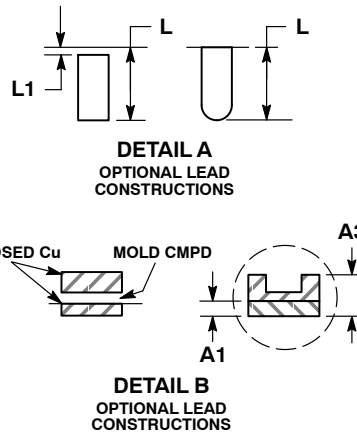
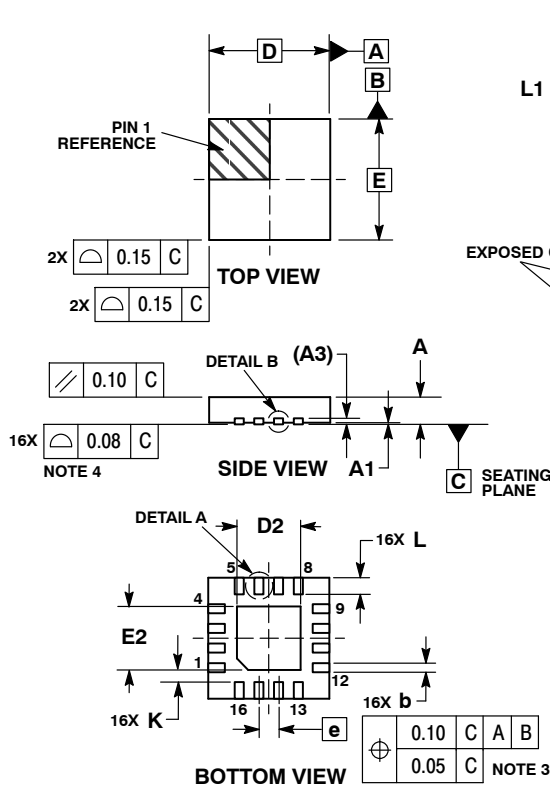

NOTES:

1. DIMENSIONING AND TOLERANCING PER ASME Y14.5M, 1994.
2. CONTROLLING DIMENSION: MILLIMETERS.
3. DIMENSION b APPLIES TO PLATED TERMINAL AND IS MEASURED BETWEEN 0.15 AND 0.30 MM FROM TERMINAL TIP.
4. COPLANARITY APPLIES TO THE EXPOSED PAD AS WELL AS THE TERMINALS.

DIM	MILLIMETERS	
	MIN	MAX
A	0.80	1.00
A1	0.00	0.05
A3	0.20	REF
b	0.25	0.35
D	4.00	BSC
D2	2.00	2.20
E	4.00	BSC
E2	2.00	2.20
e	0.65	BSC
K	0.20	---
L	0.45	0.65
L1	---	0.15

MOUNTING FOOTPRINT*

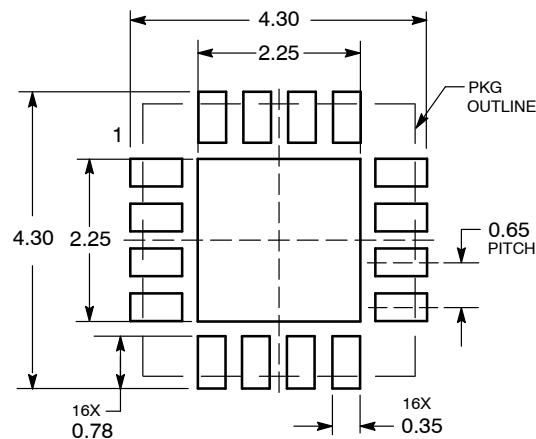

DIMENSIONS: MILLIMETERS

*For additional information on our Pb-Free strategy and soldering details, please download the ON Semiconductor Soldering and Mounting Techniques Reference Manual, SOLDERRM/D.

ON Semiconductor and are registered trademarks of Semiconductor Components Industries, LLC (SCILLC). SCILLC reserves the right to make changes without further notice to any products herein. SCILLC makes no warranty, representation or guarantee regarding the suitability of its products for any particular purpose, nor does SCILLC assume any liability arising out of the application or use of any product or circuit, and specifically disclaims any and all liability, including without limitation special, consequential or incidental damages. "Typical" parameters which may be provided in SCILLC data sheets and/or specifications can and do vary in different applications and actual performance may vary over time. All operating parameters, including "Typicals" must be validated for each customer application by customer's technical experts. SCILLC does not convey any license under its patent rights nor the rights of others. SCILLC products are not designed, intended, or authorized for use as components in systems intended for surgical implant into the body, or other applications intended to support or sustain life, or for any other application in which the failure of the SCILLC product could create a situation where personal injury or death may occur. Should Buyer purchase or use SCILLC products for any such unintended or unauthorized application, Buyer shall indemnify and hold SCILLC and its officers, employees, subsidiaries, affiliates, and distributors harmless against all claims, costs, damages, and expenses, and reasonable attorney fees arising out of, directly or indirectly, any claim of personal injury or death associated with such unintended or unauthorized use, even if such claim alleges that SCILLC was negligent regarding the design or manufacture of the part. SCILLC is an Equal Opportunity/Affirmative Action Employer. This literature is subject to all applicable copyright laws and is not for resale in any manner.

PUBLICATION ORDERING INFORMATION

LITERATURE FULFILLMENT:
Literature Distribution Center for ON Semiconductor
P.O. Box 5163, Denver, Colorado 80217 USA
Phone: 303-675-2175 or 800-344-3860 Toll Free USA/Canada
Fax: 303-675-2176 or 800-344-3867 Toll Free USA/Canada
Email: orderlit@onsemi.com



N. American Technical Support: 800-282-9855 Toll Free USA/Canada
Europe, Middle East and Africa Technical Support: Phone: 421 33 790 2910
Japan Customer Focus Center Phone: 81-3-5773-3850

ON Semiconductor Website: www.onsemi.com
Order Literature: <http://www.onsemi.com/orderlit>

For additional information, please contact your local Sales Representative

Looking for pricing, stock, or lifecycle information?

Click below to explore more details on WIN SOURCE:

-  [View NCP5212AGEVB on WIN SOURCE](#)
-  [ON Semiconductor Information](#)

Optimize Your Supply Chain with WIN SOURCE Solutions

-  Global Sourcing Solution
-  Obsolete Management
-  Cost Control Management
-  Shortage Management
-  Alternative Solution
-  Excess Inventory Management