

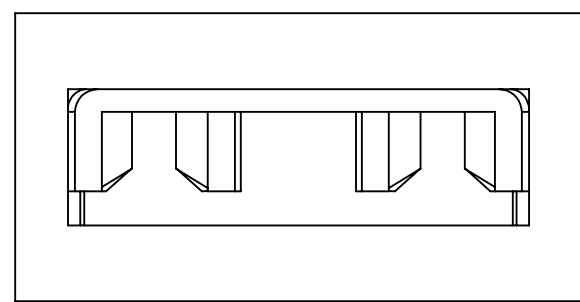

**THE DATASHEET OF
NPB02SVAN-RC**

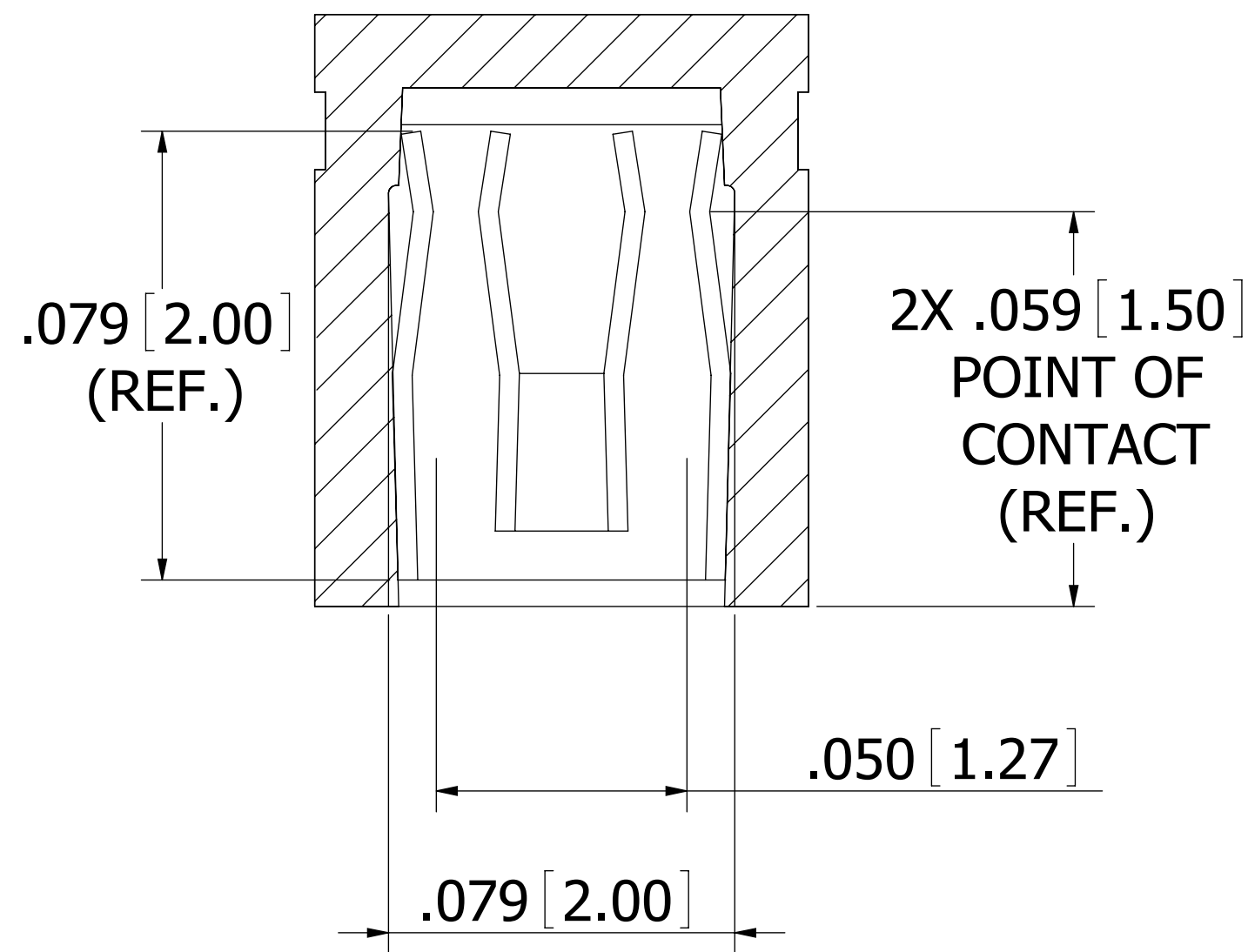

REVISIONS				
REV.	ECO. NO	DESCRIPTION	DATE	BY
A	2144	INITIAL RELEASE	07/16/2010	LH

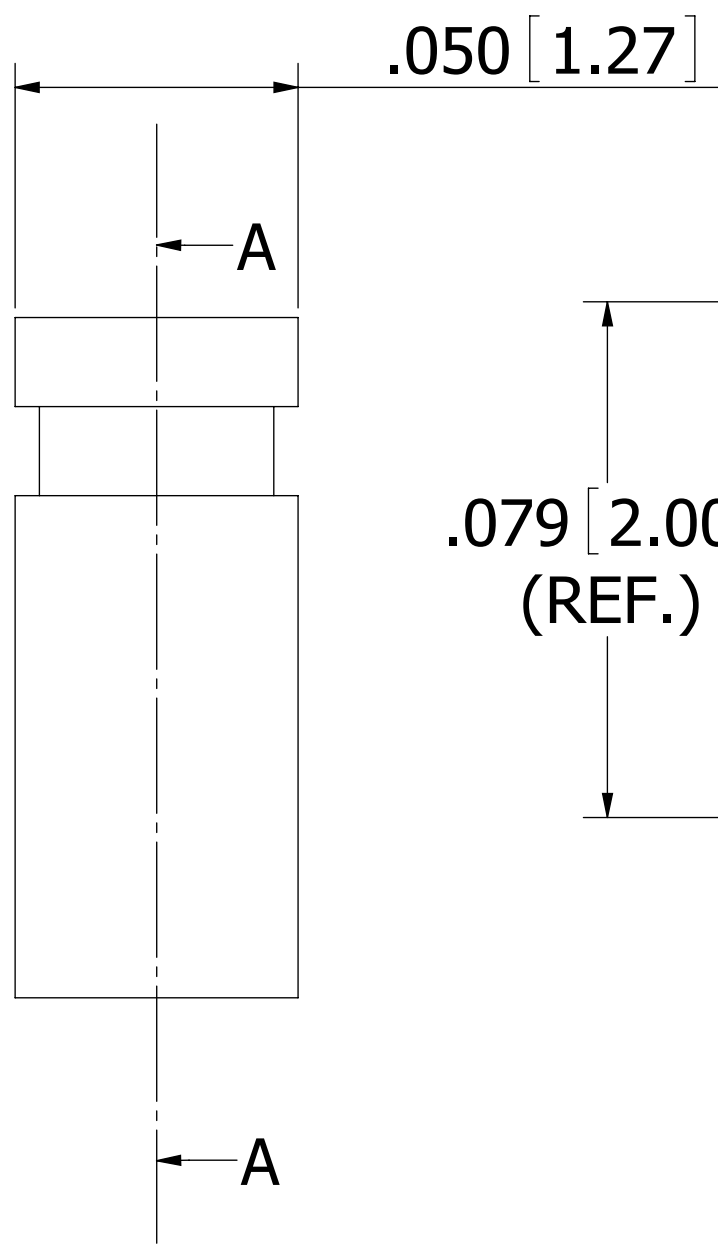
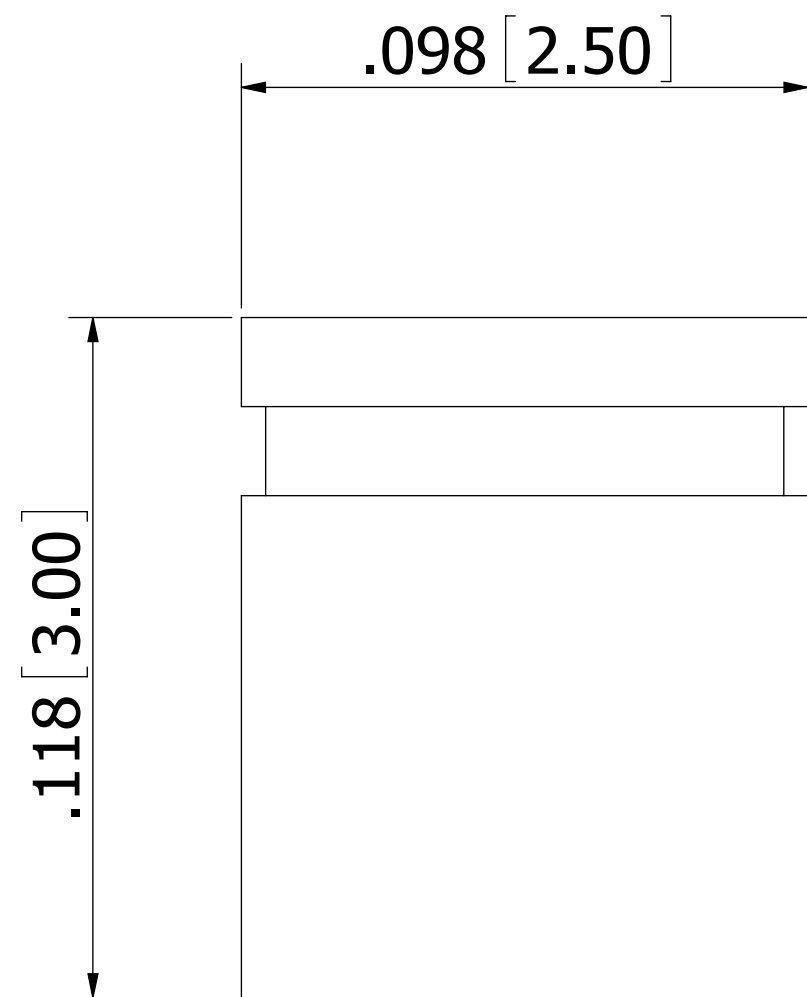
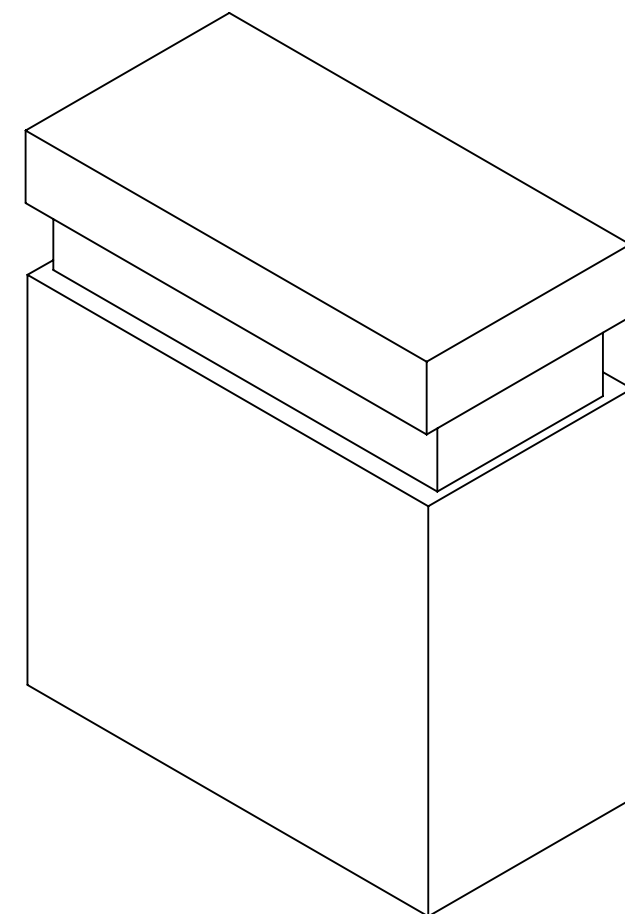

SECTION A - A

NOTES:

1. INSULATOR MATERIAL: NYLON 66.
2. CONTACT MATERIAL: PHOSPHOR BRONZE.
3. PLATING: GOLD FLASH OVERALL.
4. UL FLAMMABILITY RATING: 94V-2.
5. DIELECTRIC WITHSTANDING VOLTAGE: 650V AC.
6. CURRENT RATING: 1 AMP PER CONTACT.
7. CONTACT RESISTANCE: 30 MILLI OHMS MAX.
8. INSULATION RESISTANCE: 1000 MEGA OHMS.
9. OPERATING TEMPERATURE: -40 °C TO +85 °C.
10. DOUBLE TUNING FORK TYPE CONTACT, ACCOMMODATES .016"[0.40mm] SQ PINS, .050"[1.27mm] PITCH LOW PROFILE MINI TYPE.

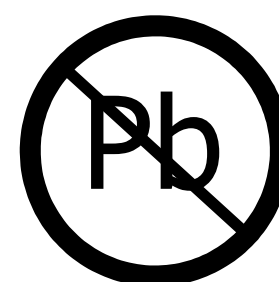



RoHS COMPLIANT

UNLESS OTHERWISE SPECIFIED:
 DIMENSIONS ARE IN INCHES[MM]
 TOLERANCES:
 ANGULAR: ± 30°
 .XX=± .012 [.30]
 .XXX=± .008 [.20]
 .XXXX=± .004 [.10]
 INTERPRET DIMENSIONS AND GEOMETRIC TOLERANCING PER: ASME Y14.5M-2009

DRAWN	7/16/2010	LH		
<small>THE INFORMATION HEREIN CONTAINS PROPRIETARY INFORMATION OF SULLINS ELECTRONICS AND IS NOT TO BE REPRODUCED, USED OR DISCLOSED TO OTHERS FOR ANY PURPOSE EXCEPT AS SPECIFICALLY AUTHORIZED IN WRITING BY AN OFFICER OF SULLINS ELECTRONICS.</small>				
<small>DESCRIPTION</small> MINI SHUNT, .050" CC, CLOSED TOP			<small>PART NUMBER</small> NPB02SVAN-RC	
SIZE	DWG. NO.	REV	<small>SCALE: 16:1</small>	
C	11499	A	<small>SHEET 1 OF 1</small>	

Looking for pricing, stock, or lifecycle information?

Click below to explore more details on WIN SOURCE:

-  [View NPB02SVAN-RC on WIN SOURCE](#)
-  [Sullins Connector Solutions](#) Information

Optimize Your Supply Chain with WIN SOURCE Solutions

-  Global Sourcing Solution
-  Obsolete Management
-  Cost Control Management
-  Shortage Management
-  Alternative Solution
-  Excess Inventory Management