



**THE DATASHEET OF
OPA2889IDGSTG4**





Dual, Low-Power, Wideband, Voltage-Feedback OPERATIONAL AMPLIFIER with Disable

FEATURES

- **FLEXIBLE SUPPLY RANGE:**
+2.6V to +12V Single Supply
±1.3V to ±6V Dual Supplies
- **UNITY-GAIN STABLE**
- **WIDEBAND ±5V OPERATION: 60MHz**
(G = +2V/V)
- **OUTPUT VOLTAGE SWING: ±4V**
- **HIGH SLEW RATE: 250V/μs**
- **LOW QUIESCENT CURRENT: 460μA/ch**
- **LOW DISABLE CURRENT: 18μA/ch**

APPLICATIONS

- **VIDEO LINE DRIVING**
- **xDSL LINE RECEIVERS**
- **HIGH-SPEED IMAGING CHANNELS**
- **ADC BUFFERS**
- **PORTABLE INSTRUMENTS**
- **TRANSIMPEDANCE AMPLIFIERS**
- **ACTIVE FILTERS**

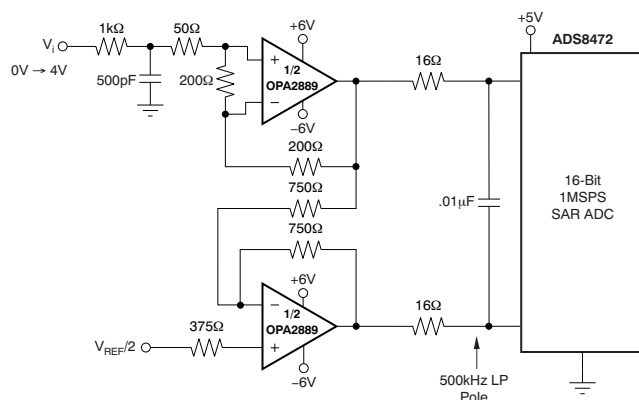

**Low Power, DC-Coupled, Single-to-Differential
Driver for ≤100kHz Inputs**

DESCRIPTION

The OPA2889 represents a major step forward in unity-gain stable, voltage-feedback op amps. A new internal architecture provides slew rate and full-power bandwidth previously found only in wideband, current-feedback op amps. These capabilities give exceptional full-power bandwidth. Using a dual ±5V supply, the OPA2889 can deliver a ±4V output swing with over 40mA drive current and 60MHz bandwidth. This combination of features makes the OPA2889 an ideal RGB line driver or single-supply analog-to-digital converter (ADC) input driver or low power twisted pair line receiver.

The low 460μA/ch supply current of the OPA2889 is precisely trimmed at +25°C. System power may be reduced further using the optional disable control pin. Leaving this disable pin open, or holding it HIGH, operates the OPA2889 normally. If pulled LOW, the OPA2889 supply current drops to less than 20μA/ch while the output goes into a high-impedance state.

RELATED OPERATIONAL AMPLIFIER PRODUCTS

	SINGLES	DUALS	TRIPLES
Low-Power Voltage-Feedback with Disable	OPA890	OPA2890	
Voltage-Feedback Amplifier with Disable (1800V/μs)	OPA690	OPA2690	OPA3690
Current-Feedback Amplifier with Disable (2100V/μs)	OPA691	OPA2691	OPA3691
Fixed Gain	OPA692		OPA3692



Please be aware that an important notice concerning availability, standard warranty, and use in critical applications of Texas Instruments semiconductor products and disclaimers thereto appears at the end of this data sheet.

All trademarks are the property of their respective owners.



This integrated circuit can be damaged by ESD. Texas Instruments recommends that all integrated circuits be handled with appropriate precautions. Failure to observe proper handling and installation procedures can cause damage.

ESD damage can range from subtle performance degradation to complete device failure. Precision integrated circuits may be more susceptible to damage because very small parametric changes could cause the device not to meet its published specifications.

ORDERING INFORMATION⁽¹⁾

PRODUCT	PACKAGE-LEAD	PACKAGE DESIGNATOR	SPECIFIED TEMPERATURE RANGE	PACKAGE MARKING	ORDERING NUMBER	TRANSPORT MEDIA, QUANTITY
OPA2889	SO-8	D	–40°C to +85°C	OP2889	OPA2889ID	Rail, 75
					OPA2889IDR	Tape and Reel, 2500
OPA2889	MSOP-10	DGS	–40°C to +85°C	BZY	OPA2889IDGST	Tape and Reel, 250
					OPA2889IDGSR	Tape and Reel, 2500

(1) For the most current package and ordering information see the Package Option Addendum at the end of this document, or see the TI web site at www.ti.com.

ABSOLUTE MAXIMUM RATINGS⁽¹⁾

Over operating free-air temperature range, unless otherwise noted.

	OPA2889	UNIT
Power supply	±6.5	V
Internal power dissipation	See Thermal Characteristics	
Input voltage range	±V _S	V
Storage temperature range	–65 to +125	°C
Lead temperature (soldering, 10s)	+260	°C
Maximum junction temperature (T _J)	+150	°C
Maximum junction temperature (T _J), continuous operation	+140	°C
ESD Rating:		
Human body model (HBM)	2000	V
Charge device model (CDM)	1000	V
Machine model (MM)	150	V

(1) Stresses above these ratings may cause permanent damage. Exposure to absolute maximum conditions for extended periods may degrade device reliability. These are stress ratings only, and functional operation of the device at these or any other conditions beyond those specified is not implied.

PIN ASSIGNMENTS

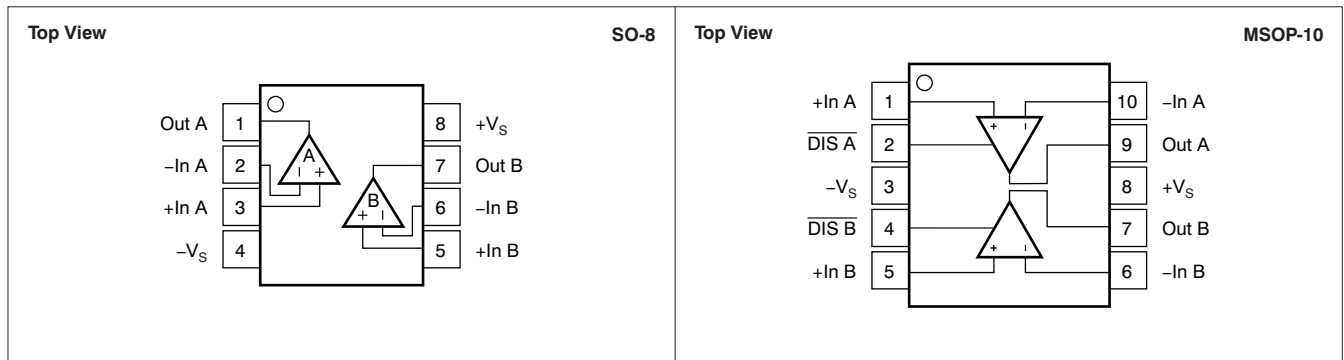

ELECTRICAL CHARACTERISTICS: $V_S = \pm 5V$

 At $T_A = +25^\circ\text{C}$, $R_F = 750\Omega$, $G = +2V/V$, and $R_L = 100\Omega$, unless otherwise noted.

PARAMETER	CONDITIONS	OPA2889ID, IDGS				UNITS	MIN/ MAX	TEST LEVEL ⁽¹⁾
		TYP	MIN/MAX OVER TEMPERATURE					
		+25°C	+25°C ⁽²⁾	0°C to +70°C ⁽³⁾	–40°C to +85°C ⁽³⁾			
AC PERFORMANCE								
Small-Signal Bandwidth	$G = +1V/V$, $V_O = 100mV_{PP}$, $R_F = 0\Omega$	115				MHz	typ	C
	$G = +2V/V$, $V_O = 100mV_{PP}$	60	40	36	32	MHz	min	B
	$G = +10V/V$, $V_O = 100mV_{PP}$	8	6	5	4.5	MHz	min	B
Gain Bandwidth Product	$G > +20V/V$	75	60	50	45	MHz	min	B
Bandwidth for 0.1dB Flatness	$G = +2V/V$, $V_O = 100mV_{PP}$	14				MHz	typ	C
Peaking at a Gain of +1V/V	$V_O < 100mV_{PP}$, $R_F = 0\Omega$	1				dB	typ	C
Large-Signal Bandwidth	$G = +2V/V$, $V_O = 2V_{PP}$	70				MHz	typ	C
Slew Rate	$G = +2V/V$, $V_O = 2V$ Step	250	175	160	150	V/ μs	min	B
Rise-and-Fall Time	0.2V Step	6				ns	typ	C
Settling Time to 0.02%	$G = +1V/V$, $V_O = 2V$ Step	36				ns	typ	C
Settling Time to 0.1%		25				ns	typ	C
Harmonic Distortion	$G = +2V/V$, $f = 1\text{MHz}$, $V_O = 2V_{PP}$							
2nd-Harmonic	$R_L = 200\Omega$	–75	–65	–62	–60	dBc	max	B
	$R_L \geq 500\Omega$	–80	–73	–68	–65	dBc	max	B
3rd-Harmonic	$R_L = 200\Omega$	–80	–74	–70	–68	dBc	max	B
	$R_L \geq 500\Omega$	–82	–80	–75	–72	dBc	max	B
Input Voltage Noise	$f > 100\text{kHz}$	8.4	10	11.5	12	nV/ $\sqrt{\text{Hz}}$	max	B
Input Current Noise	$f > 100\text{kHz}$	0.7	1	1.2	1.4	pA/ $\sqrt{\text{Hz}}$	max	B
Differential Gain	$G = +2V/V$, $V_O = 1.4V_{PP}$, $R_L = 150\Omega$	0.06				%	typ	C
Differential Phase	$G = +2V/V$, $V_O = 1.4V_{PP}$, $R_L = 150\Omega$	0.04				°	typ	C
Channel-to-Channel Crosstalk	$f = 5\text{MHz}$, Input-referred	–85				dB	typ	C
DC PERFORMANCE ⁽⁴⁾								
Open-Loop Voltage Gain (A_{OL})	$V_O = 0V$, $R_L = 100\Omega$	66	60	58	57	dB	min	A
Input Offset Voltage	$V_{CM} = 0V$	± 1.5	± 5	± 5.9	± 6.3	mV	max	A
Average Offset Voltage Drift	$V_{CM} = 0V$			± 20	± 20	$\mu\text{V}/^\circ\text{C}$	max	B
Input Bias Current	$V_{CM} = 0V$	± 150	± 750	± 840	± 880	nA	max	A
Average Input Bias Current Drift	$V_{CM} = 0V$			± 2	± 2	nA/ $^\circ\text{C}$	max	B
Input Offset Current	$V_{CM} = 0V$	± 50	± 200	± 225	± 235	nA	max	A
Average Input Offset Current Drift	$V_{CM} = 0V$			± 0.5	± 0.5	nA/ $^\circ\text{C}$	max	B
INPUT								
Common-Mode Input Range (CMIR) ⁽⁵⁾		± 3.9	± 3.8	± 3.7	± 3.6	V	min	A
Common-Mode Rejection Ratio (CMRR)	$V_{CM} = 0V$, Input-referred	70	60	59	58	dB	min	A
Input Impedance								
Differential	$V_{CM} = 0V$	3.5 0.5				M Ω pF	typ	C
Common-Mode	$V_{CM} = 0V$	170 0.8				M Ω pF	typ	C

- (1) Test levels: **(A)** 100% tested at +25°C. Over temperature limits set by characterization and simulation. **(B)** Limits set by characterization and simulation. **(C)** Typical value only for information.
- (2) Junction temperature = ambient for +25°C tested specifications.
- (3) Junction temperature = ambient at low temperature limit; junction temperature = ambient +4°C at high temperature limit for over temperature specifications.
- (4) Current is considered positive out-of-node. V_{CM} is the input common-mode voltage.
- (5) Tested < 3dB below minimum specified CMRR at $\pm\text{CMIR}$ limits

ELECTRICAL CHARACTERISTICS: $V_S = \pm 5V$ (continued)At $T_A = +25^\circ\text{C}$, $R_F = 750\Omega$, $G = +2V/V$, and $R_L = 100\Omega$, unless otherwise noted.

PARAMETER	CONDITIONS	OPA2889ID, IDGS				UNITS	MIN/ MAX	TEST LEVEL ⁽¹⁾
		TYP	MIN/MAX OVER TEMPERATURE					
		+25°C	+25°C ⁽²⁾	0°C to +70°C ⁽³⁾	–40°C to +85°C ⁽³⁾			
OUTPUT								
Output Voltage Swing	No load	±4.0	±3.9	±3.8	±3.7	V	min	A
	$R_L = 100\Omega$	±3.3	±3.0	±2.95	±2.85	V	min	A
Output Current, Sourcing, Sinking	$V_O = 0V$	±40	±28	±25	±22	mA	min	A
Peak Output Current	Output shorted to ground	±60				mA	typ	C
Closed-Loop Output Impedance	$G = +2V/V$, $f = 100\text{kHz}$	0.04				Ω	typ	C
DISABLE (MSOP-10 ONLY)								
Power-Down Supply Current ($+V_S$)	Disable LOW $V_{DIS} = 0$, Both channels	36	50	53	55	μA	max	A
Disable Time	$V_{IN} = 1V_{DC}$	70				μs	typ	C
Enable Time	$V_{IN} = 1V_{DC}$	200				ns	typ	C
Off Isolation	$G = +2V/V$, $f = 5\text{MHz}$	70				dB	typ	C
Output Capacitance in Disable		4				pF	typ	C
Enable Voltage		3.3	3.4	3.5	3.55	V	min	A
Disable Voltage		1.2	1.0	0.9	0.85	V	max	A
Control Pin Input Bias Current (V_{DIS})	$V_{DIS} = 0V$, Each channel	15	25	30	35	μA	max	A
POWER SUPPLY								
Specified Operating Voltage		±5				V	typ	C
Minimum Operating Voltage			1.3			V	typ	C
Maximum Operating Voltage			±6.0	±6.0	±6.0	V	max	A
Maximum Quiescent Current	$V_S = \pm 5V$, Both channels	0.92	1	1.05	1.1	mA	max	A
Minimum Quiescent Current	$V_S = \pm 5V$, Both channels	0.92	0.8	0.75	0.7	mA	min	A
Power-Supply Rejection (+PSRR) Ratio	$+V_S = 4.5V$ to $5.5V$	64	62	61	60	dB	min	A
	$-V_S = -4.5V$ to $-5.5V$	74	72	71	70	dB	min	A
THERMAL CHARACTERISTICS								
Specified Operating Range D and DGS Packages		–40 to +85				$^\circ\text{C}$	typ	C
Thermal Resistance, θ_{JA}	Junction-to-ambient							
D	SO-8	100				$^\circ\text{C/W}$	typ	C
DGS	MSOP-10	135				$^\circ\text{C/W}$	typ	C

ELECTRICAL CHARACTERISTICS: $V_S = +5V$

 At $T_A = +25^\circ\text{C}$, $R_F = 750\Omega$, $G = +2V/V$, and $R_L = 100\Omega$, unless otherwise noted.

PARAMETER	CONDITIONS	OPA2889ID, IDGS				UNITS	MIN/ MAX	TEST LEVEL ⁽¹⁾
		TYP	MIN/MAX OVER TEMPERATURE					
			+25°C	+25°C ⁽²⁾	0°C to +70°C ⁽³⁾			
AC PERFORMANCE								
Small-Signal Bandwidth	$G = +1V/V$, $V_O = 100mV_{PP}$, $R_F = 0\Omega$	100				MHz	typ	C
	$G = +2V/V$, $V_O = 100mV_{PP}$	50	30	26	22	MHz	min	B
	$G = +10V/V$, $V_O = 100mV_{PP}$	7	5.5	4.5	4	MHz	min	B
Gain Bandwidth Product	$G > +20V/V$	70	55	45	40	MHz	min	B
Bandwidth for 0.1dB Flatness	$G = +2V/V$, $V_O = 100mV_{PP}$	14				MHz	typ	C
Peaking at a Gain of +1V/V	$V_O < 100mV_{PP}$, $R_F = 0\Omega$	1				dB	typ	C
Large-Signal Bandwidth	$G = +2V/V$, $V_O = 2V_{PP}$	60				MHz	typ	C
Slew Rate	$G = +2V/V$, $V_O = 2V$ Step	200	125	110	100	V/ μs	min	B
Rise-and-Fall Time	0.2V Step	6.5				ns	typ	C
Settling Time to 0.02%	$G = +1V/V$, $V_O = 2V$ Step	38				ns	typ	C
Settling Time to 0.1%		27				ns	typ	C
Harmonic Distortion	$G = +2V/V$, $f = 1\text{MHz}$, $V_O = 2V_{PP}$							
2nd-Harmonic	$R_L = 200\Omega$	–71	–61	–58	–56	dBc	max	B
	$R_L \geq 500\Omega$	–76	–69	–64	–61	dBc	max	B
3rd-Harmonic	$R_L = 200\Omega$	–76	–70	–66	–64	dBc	max	B
	$R_L \geq 500\Omega$	–76	–74	–69	–66	dBc	max	B
Input Voltage Noise	$f > 100\text{kHz}$	8.5	10.5	12	12.5	nV/ $\sqrt{\text{Hz}}$	max	B
Input Current Noise	$f > 100\text{kHz}$	0.7	1	1.1	1.2	pA/ $\sqrt{\text{Hz}}$	max	B
Differential Gain	$G = +2V/V$, $V_O = 1.4V_{PP}$, $R_L = 150\Omega$	0.06				%	typ	C
Differential Phase	$G = +2V/V$, $V_O = 1.4V_{PP}$, $R_L = 150\Omega$	0.04				°	typ	C
Channel-to-Channel Crosstalk	$f = 5\text{MHz}$, Input-referred	–85				dB	typ	C
DC PERFORMANCE ⁽⁴⁾								
Open-Loop Voltage Gain (A_{OL})	$V_O = 0V$, $R_L = 100\Omega$	64	58	56	55	dB	min	A
Input Offset Voltage	$V_{CM} = 0V$	± 1.5	± 5	± 5.9	± 6.3	mV	max	A
Average Offset Voltage Drift	$V_{CM} = 0V$			± 20	± 20	$\mu\text{V}/^\circ\text{C}$	max	B
Input Bias Current	$V_{CM} = 0V$	± 150	± 800	± 890	± 930	nA	max	A
Average Input Bias Current Drift	$V_{CM} = 0V$			± 2	± 2	nA/ $^\circ\text{C}$	max	B
Input Offset Current	$V_{CM} = 0V$	± 50	± 250	± 275	± 285	nA	max	A
Average Input Offset Current Drift	$V_{CM} = 0V$			± 0.5	± 0.5	nA/ $^\circ\text{C}$	max	B
INPUT								
Most Positive Input Voltage		4	3.9	3.8	3.75	V	min	A
Least Positive Input Voltage		1	1.1	1.2	1.25	V	max	A
Common-Mode Rejection Ratio (CMRR)	$V_{CM} = 0V$, Input-referred	68	58	57	56	dB	min	A
Input Impedance								
Differential	$V_{CM} = 0V$	3.5 0.5				M Ω pF	typ	C
Common-Mode	$V_{CM} = 0V$	170 0.8				M Ω pF	typ	C

- (1) Test levels: **(A)** 100% tested at +25°C. Over temperature limits set by characterization and simulation. **(B)** Limits set by characterization and simulation. **(C)** Typical value only for information.
- (2) Junction temperature = ambient for +25°C tested specifications.
- (3) Junction temperature = ambient at low temperature limit; junction temperature = ambient +4°C at high temperature limit for over temperature specifications.
- (4) Current is considered positive out-of-node. V_{CM} is the input common-mode voltage.

ELECTRICAL CHARACTERISTICS: $V_S = +5V$ (continued)At $T_A = +25^\circ\text{C}$, $R_F = 750\Omega$, $G = +2V/V$, and $R_L = 100\Omega$, unless otherwise noted.

PARAMETER	CONDITIONS	OPA2889ID, IDGS				UNITS	MIN/ MAX	TEST LEVEL ⁽¹⁾
		TYP	MIN/MAX OVER TEMPERATURE					
			+25°C	+25°C ⁽²⁾	0°C to +70°C ⁽³⁾			
OUTPUT								
Most Positive Output Voltage	No load	4	3.9	3.8	3.7	V	min	A
	$R_L = 100\Omega$	3.85	3.7	3.6	3.55	V	min	A
Least Positive Output Voltage	No Load	1	1.1	1.2	1.3	V	max	A
	$R_L = 100\Omega$	1.15	1.3	1.4	1.45	V	max	A
Output Current, Sourcing, Sinking	$V_O = 0V$	± 35	± 24	± 21	± 18	mA	min	A
Peak Output Current	Output shorted to ground	± 50				mA	typ	C
Closed-Loop Output Impedance	$G = +2V/V$, $f = 100\text{kHz}$	0.04				Ω	typ	C
DISABLE (MSOP-10 ONLY)								
Power-Down Supply Current ($+V_S$)	Disable LOW $V_{DIS} = 0$, both channels	36	50	53	55	μA	max	A
Disable Time	$V_{IN} = 1V_{DC}$	70				μs	typ	C
Enable Time	$V_{IN} = 1V_{DC}$	200				ns	typ	C
Off Isolation	$G = +2V/V$, $f = 5\text{MHz}$	70				dB	typ	C
Output Capacitance in Disable		4				pF	typ	C
Enable Voltage		3.3	3.4	3.5	3.55	V	min	A
Disable Voltage		1.2	1.0	0.9	0.85	V	max	A
Control Pin Input Bias Current (V_{DIS})	$V_{DIS} = 0V$, Each channel	15	25	30	35	μA	max	A
POWER SUPPLY								
Specified Operating Voltage		+5				V	typ	C
Minimum Operating Voltage			+2.6			V	typ	C
Maximum Operating Voltage			+12	+12	+12	V	max	A
Maximum Quiescent Current	$V_S = +5V$, Both channels	0.85	0.95	1.0	1.05	mA	max	A
Minimum Quiescent Current	$V_S = +5V$, Both channels	0.85	0.75	0.7	0.65	mA	min	A
Power-Supply Rejection (+PSRR) Ratio	$+V_S = 4.5V$ to $5.5V$	60				dB	typ	C
THERMAL CHARACTERISTICS								
Specified Operating Range D and DGS Packages		–40 to +85				$^\circ\text{C}$	typ	C
Thermal Resistance, θ_{JA}	Junction-to-ambient							
D	SO-8	100				$^\circ\text{C/W}$	typ	C
DGS	MSOP-10	135				$^\circ\text{C/W}$	typ	C

TYPICAL CHARACTERISTICS: $V_S = \pm 5V$

At $T_A = +25^\circ C$, $G = +2V/V$, $R_F = 750\Omega$, and $R_L = 100\Omega$, unless otherwise noted. See Figure 50.

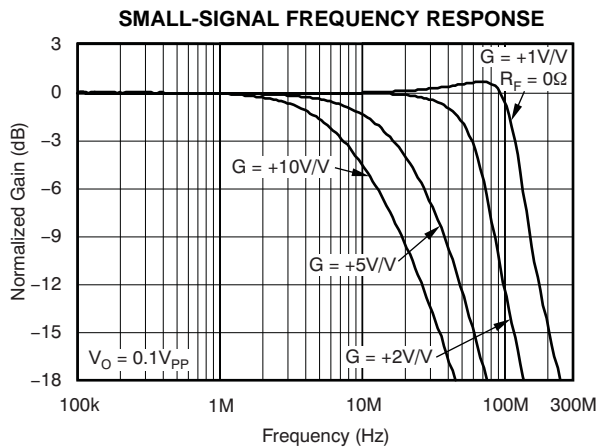

Figure 1.

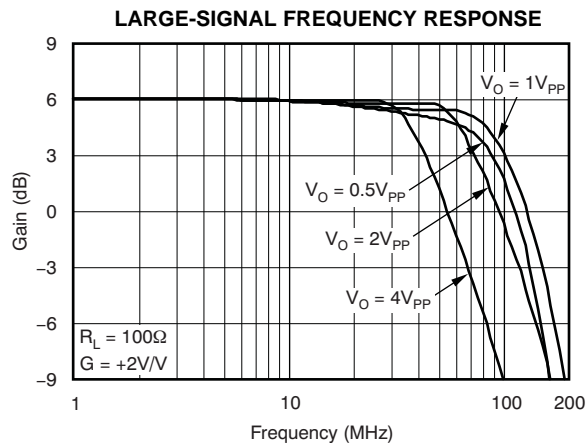

Figure 2.

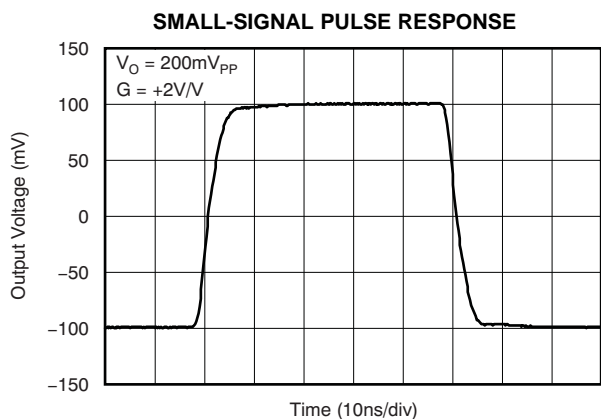

Figure 3.

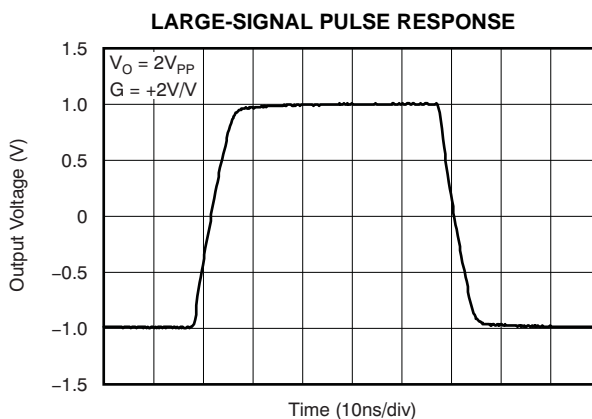

Figure 4.

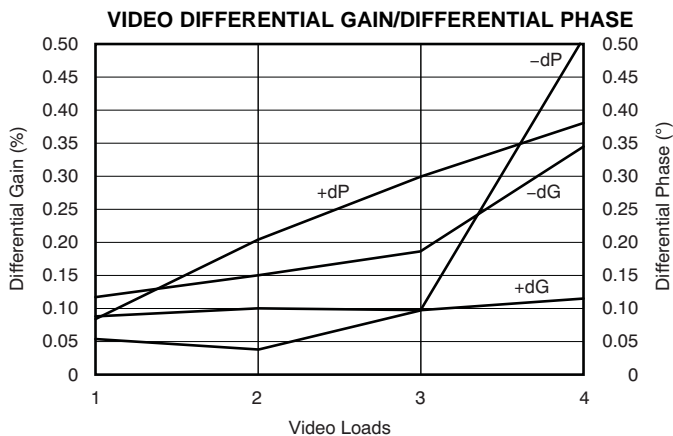

Figure 5.

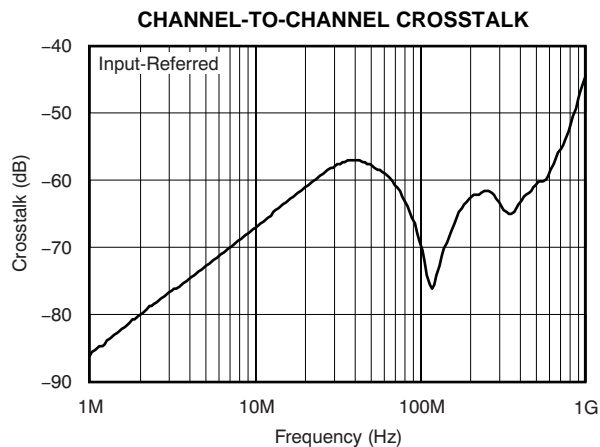

Figure 6.

TYPICAL CHARACTERISTICS: $V_S = \pm 5V$ (continued)

At $T_A = +25^\circ C$, $G = +2V/V$, $R_F = 750\Omega$, and $R_L = 100\Omega$, unless otherwise noted. See Figure 50.

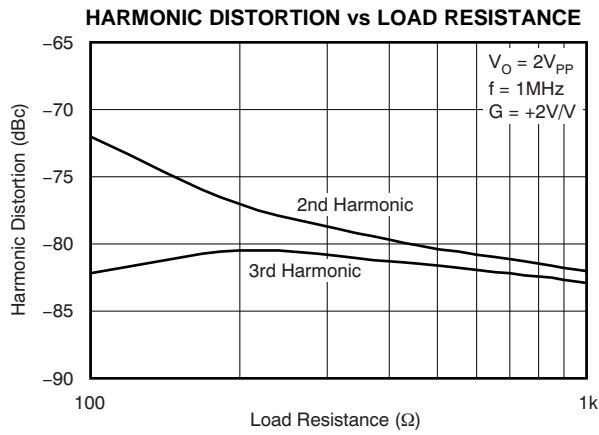

Figure 7.

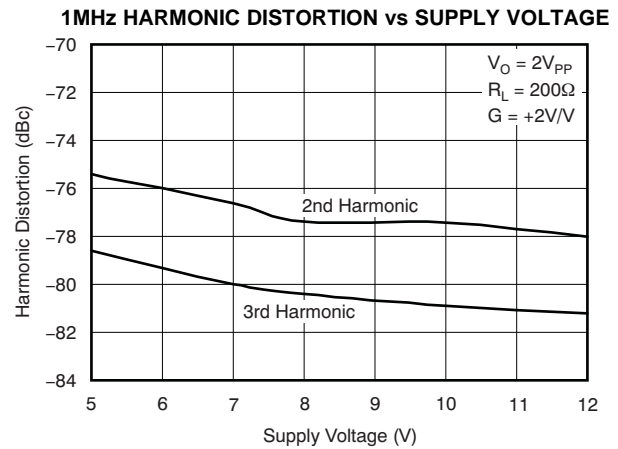

Figure 8.

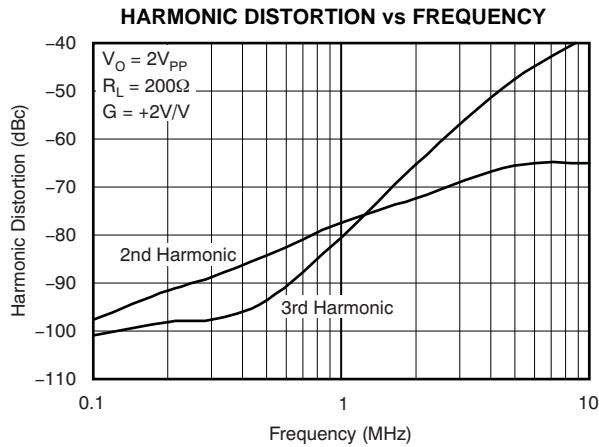

Figure 9.

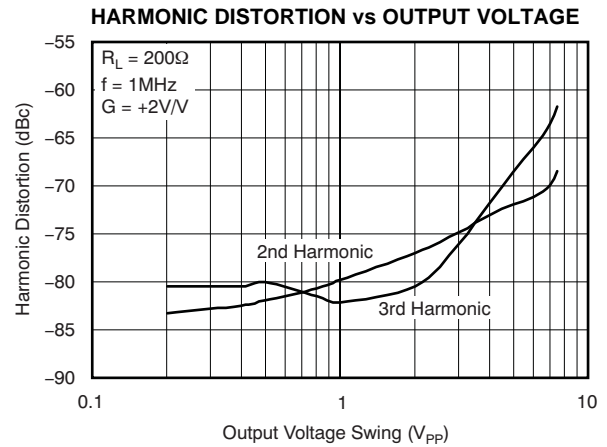

Figure 10.

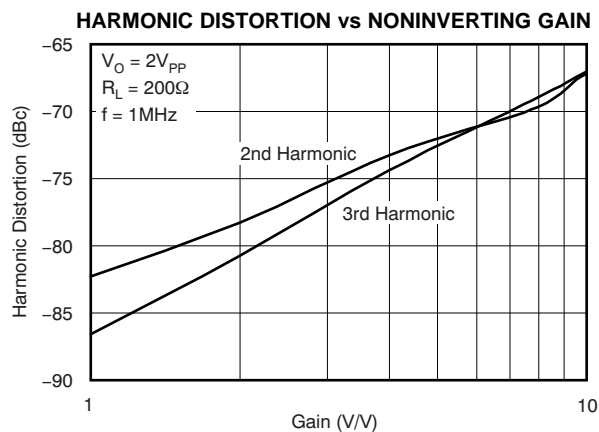

Figure 11.

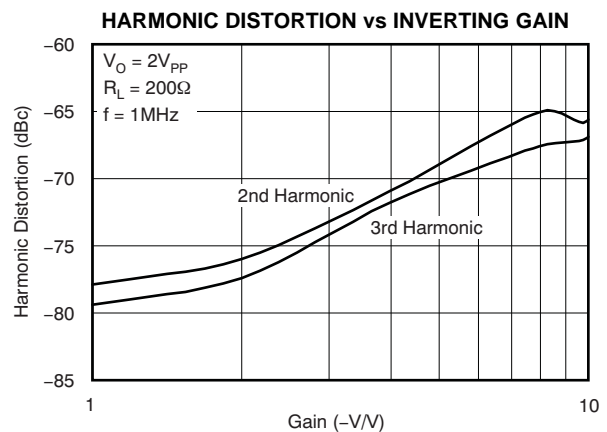

Figure 12.

TYPICAL CHARACTERISTICS: $V_S = \pm 5V$ (continued)

At $T_A = +25^\circ C$, $G = +2V/V$, $R_F = 750\Omega$, and $R_L = 100\Omega$, unless otherwise noted. See Figure 50.

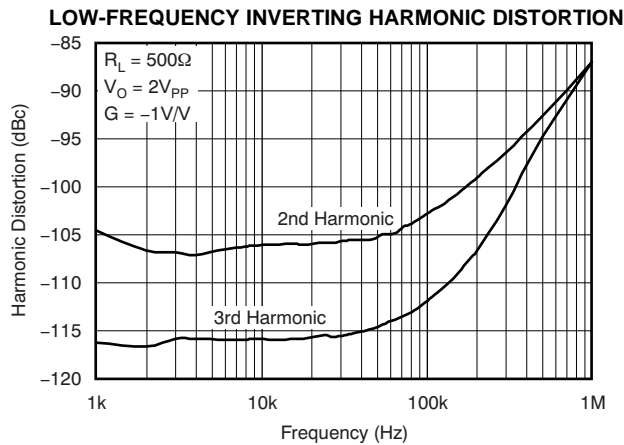

Figure 13.

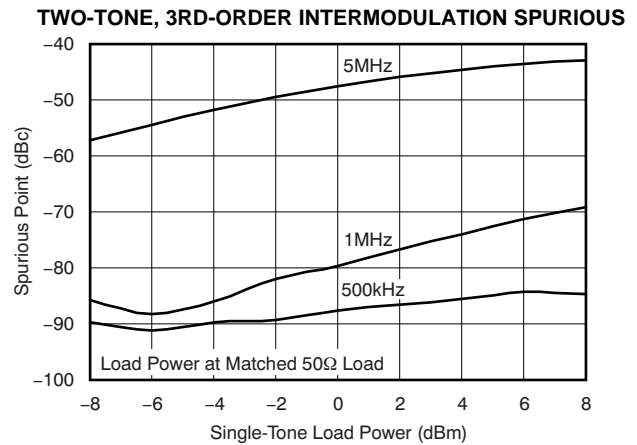

Figure 14.

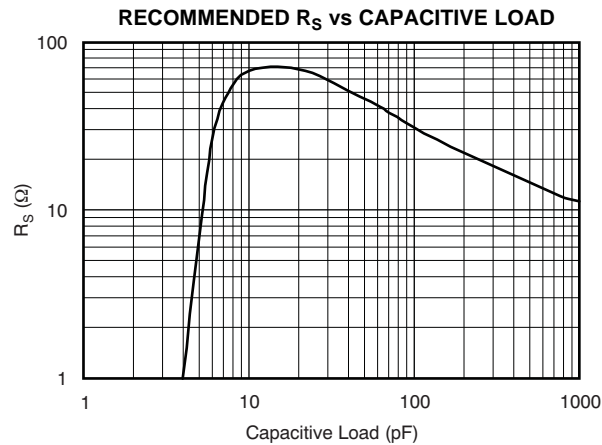

Figure 15.

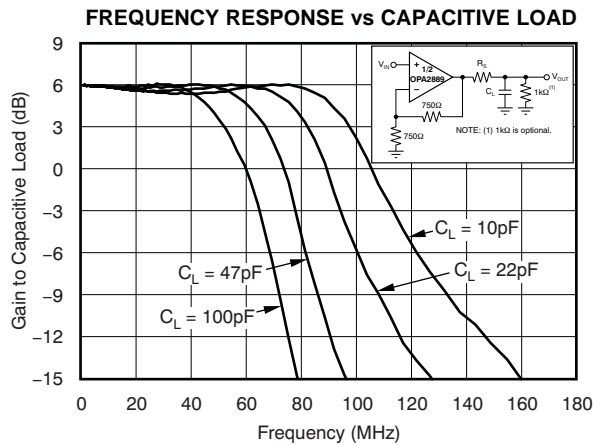

Figure 16.

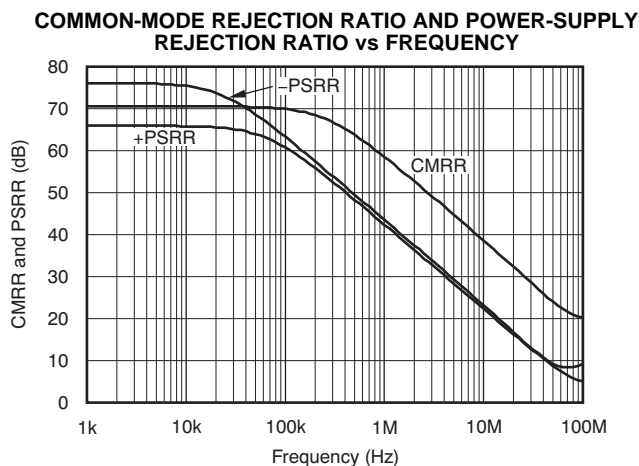

Figure 17.

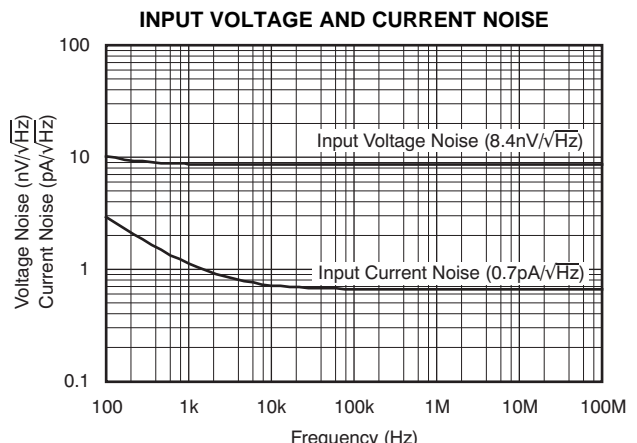

Figure 18.

TYPICAL CHARACTERISTICS: $V_S = \pm 5V$ (continued)

At $T_A = +25^\circ C$, $G = +2V/V$, $R_F = 750\Omega$, and $R_L = 100\Omega$, unless otherwise noted. See Figure 50.

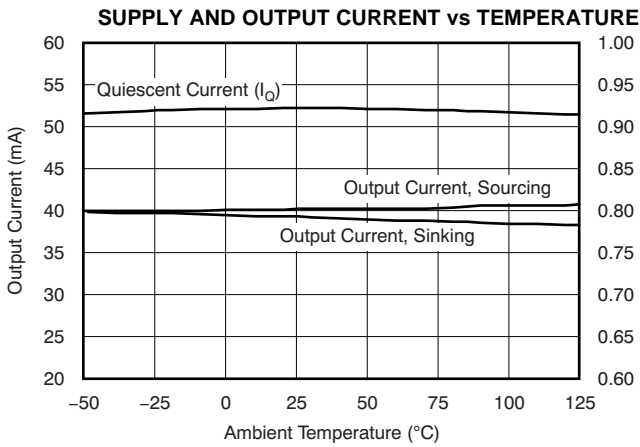

Figure 19.

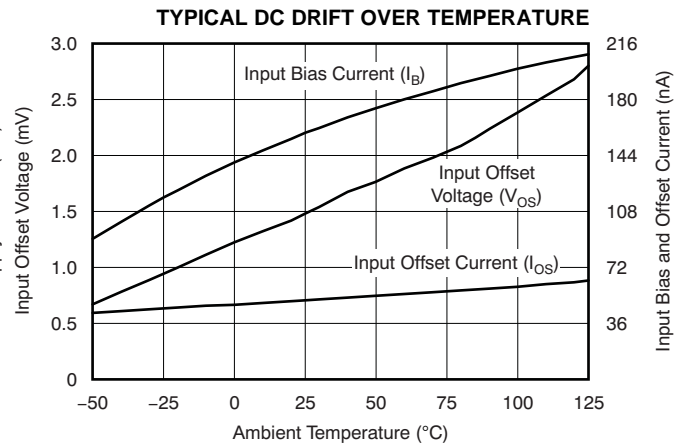

Figure 20.

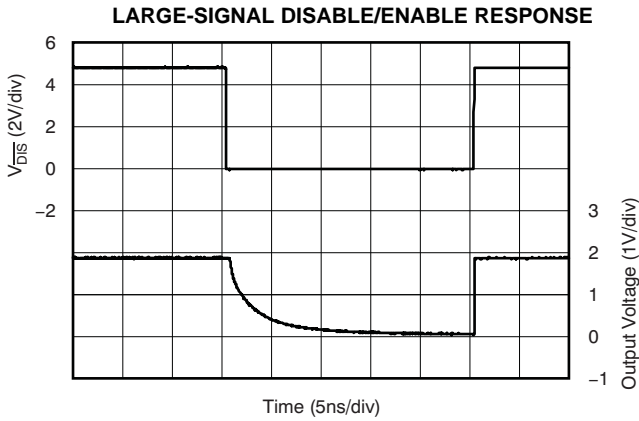

Figure 21.

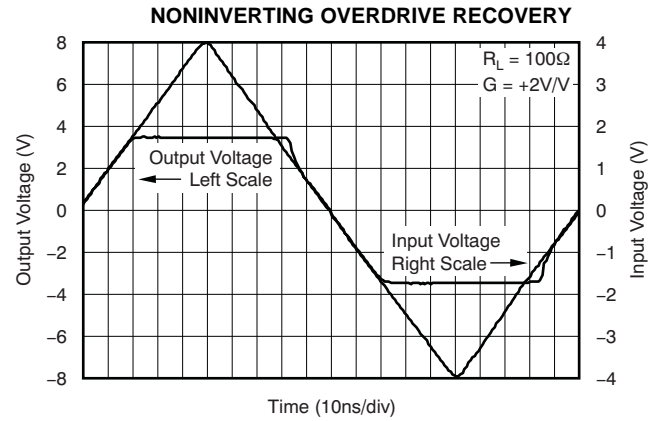

Figure 22.

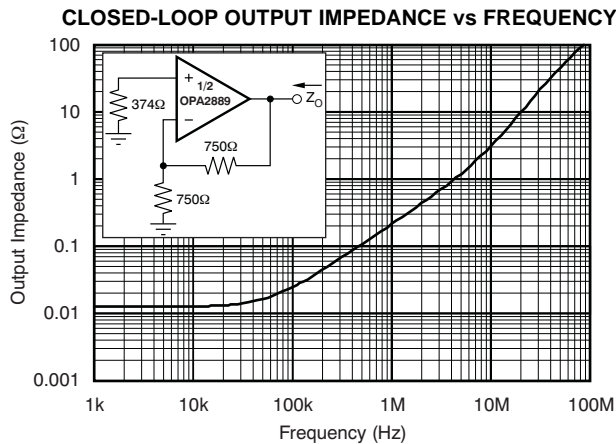

Figure 23.

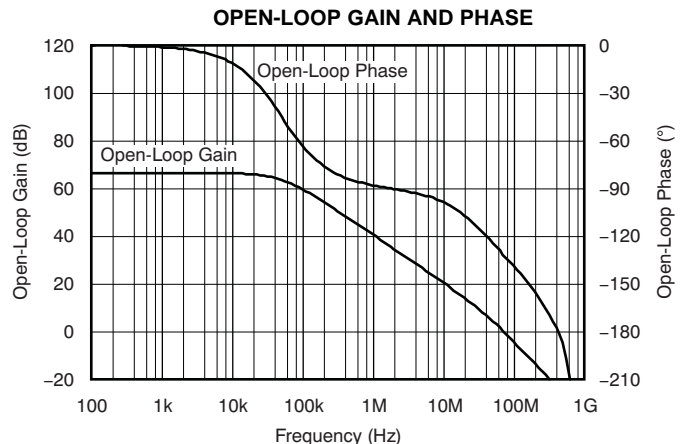

Figure 24.

TYPICAL CHARACTERISTICS: $V_S = \pm 5V$ (continued)

At $T_A = +25^\circ C$, $G = +2V/V$, $R_F = 750\Omega$, and $R_L = 100\Omega$, unless otherwise noted. See [Figure 50](#).

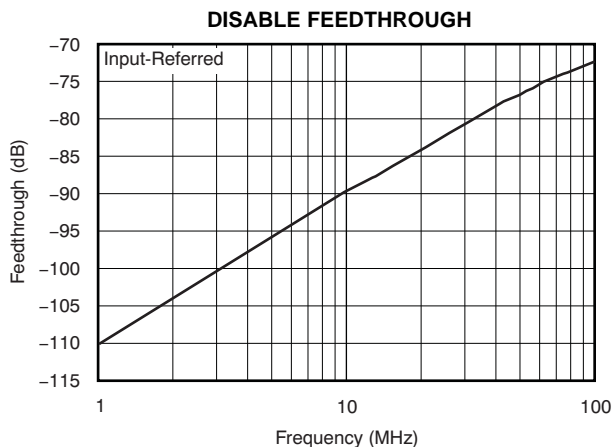

Figure 25.

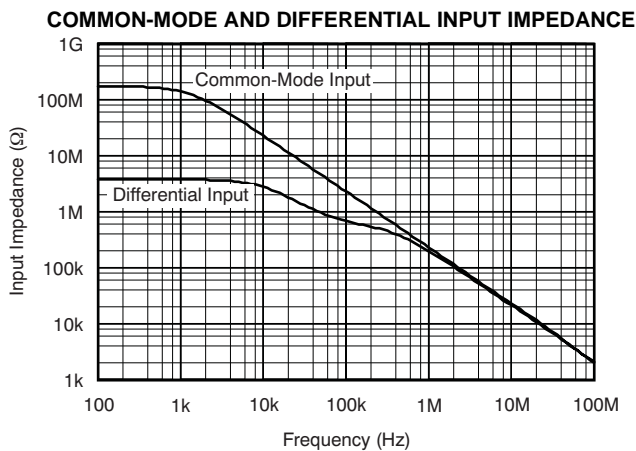

Figure 26.

TYPICAL CHARACTERISTICS: $V_S = \pm 5V$, Differential

At $T_A = +25^\circ C$, Differential Gain = $+2V/V$, and $R_L = 200\Omega$, unless otherwise noted. See Figure 52 and Figure 53.

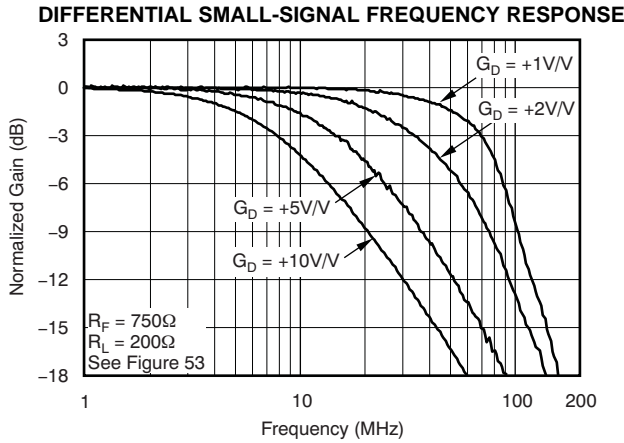

Figure 27.

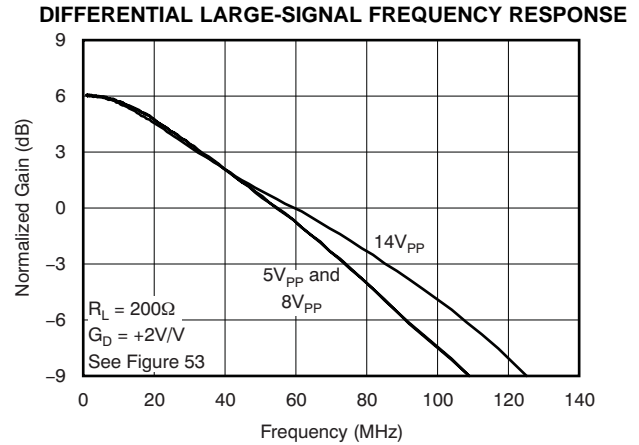

Figure 28.

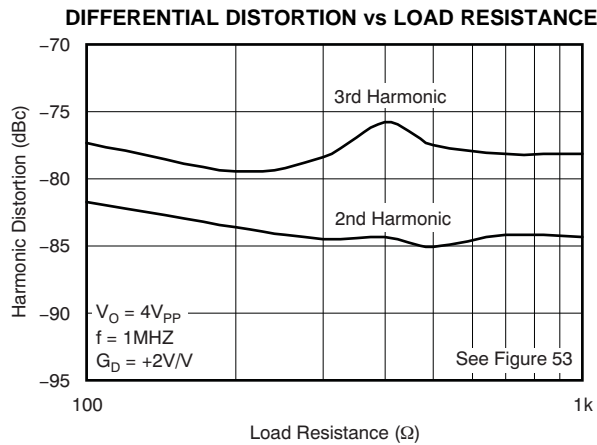

Figure 29.

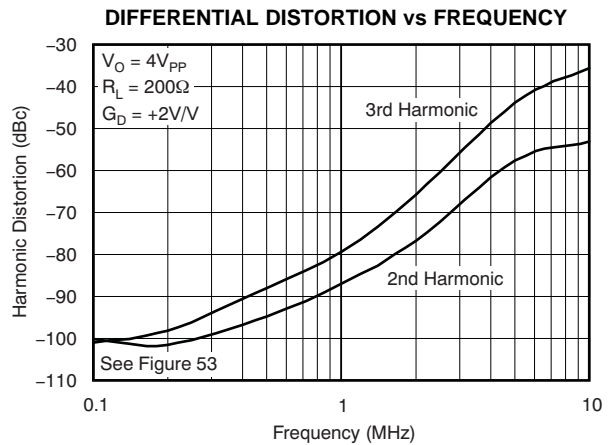

Figure 30.

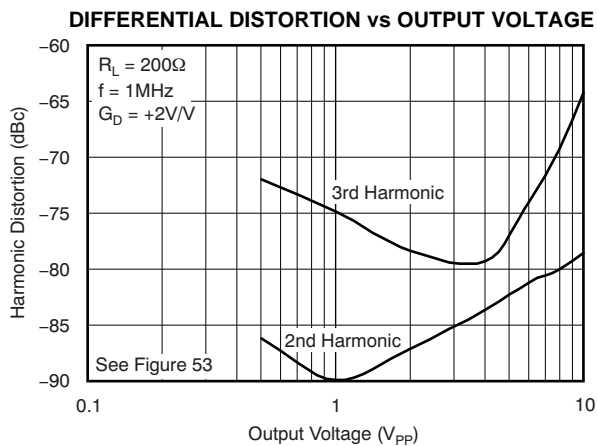

Figure 31.

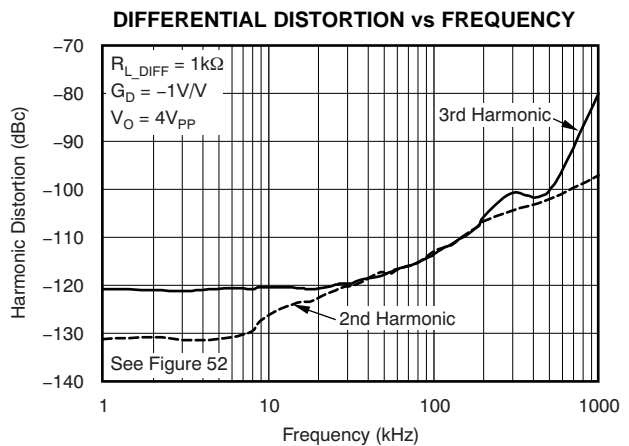

Figure 32.

TYPICAL CHARACTERISTICS: $V_S = +5V$

At $T_A = +25^\circ C$, $G = +2V/V$, $R_F = 750\Omega$, and $R_L = 100\Omega$, unless otherwise noted. See Figure 51.

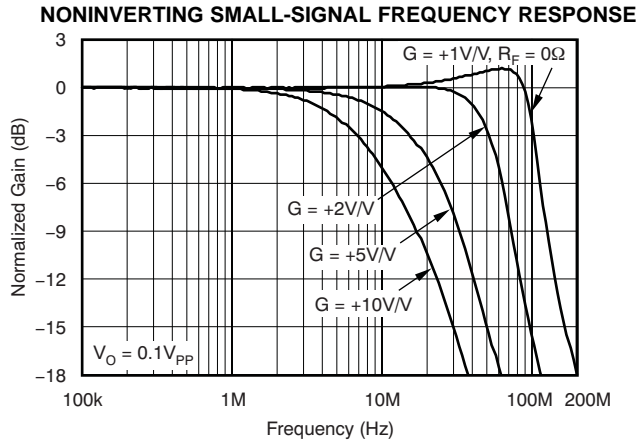

Figure 33.

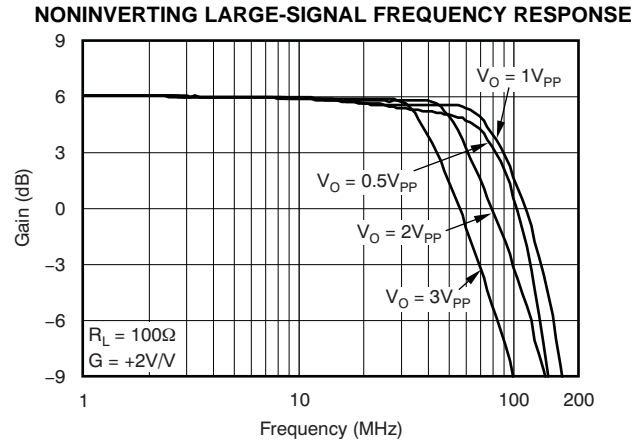

Figure 34.

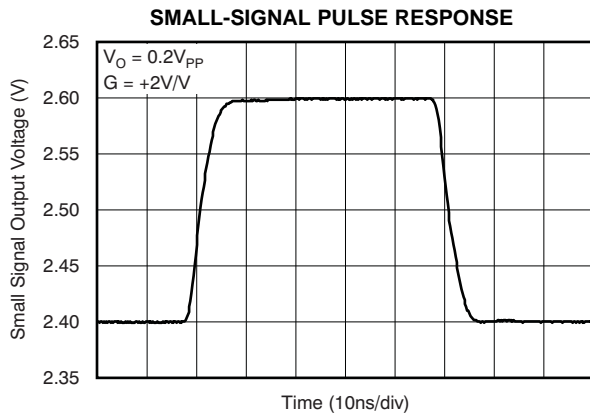

Figure 35.

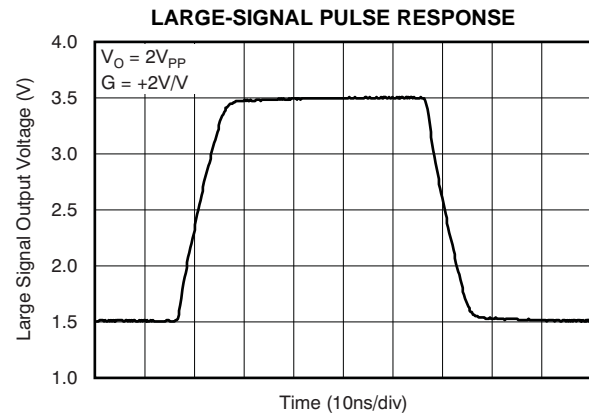

Figure 36.

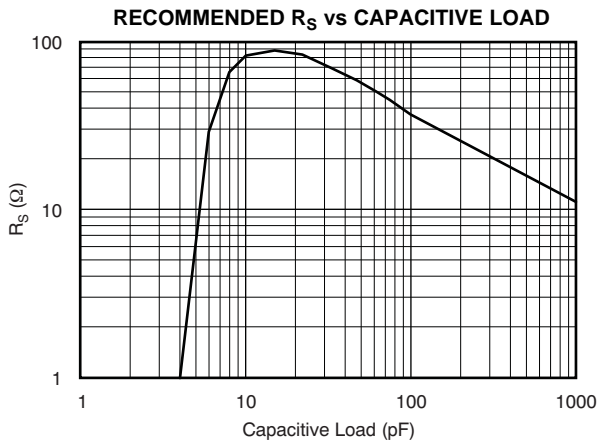

Figure 37.

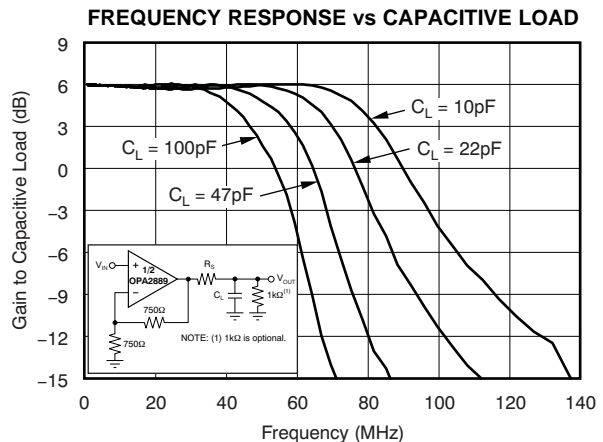

Figure 38.

TYPICAL CHARACTERISTICS: $V_S = +5V$ (continued)

At $T_A = +25^\circ C$, $G = +2V/V$, $R_F = 750\Omega$, and $R_L = 100\Omega$, unless otherwise noted. See Figure 51.

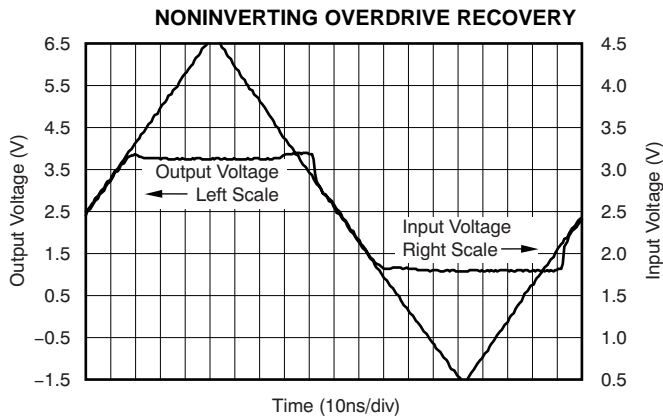

Figure 39.

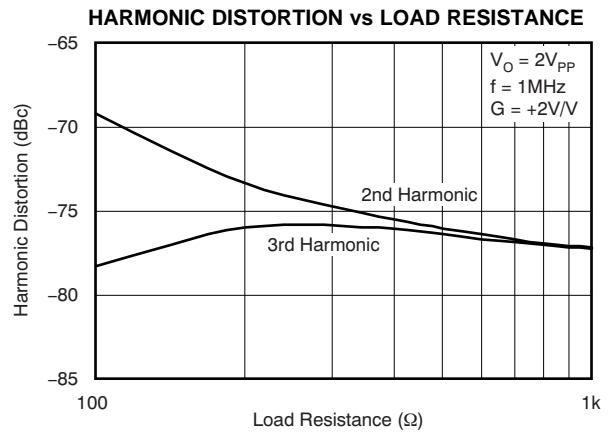

Figure 40.

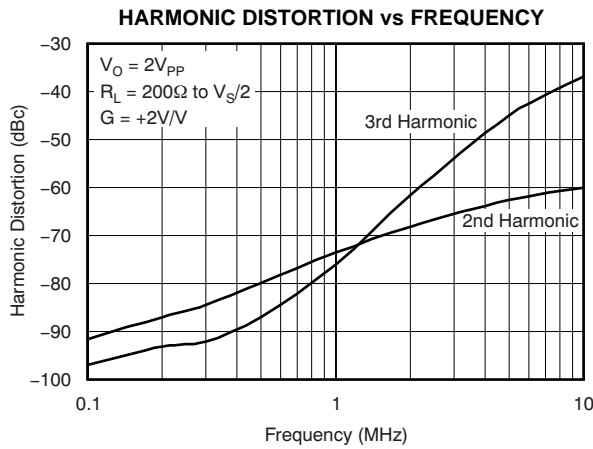

Figure 41.

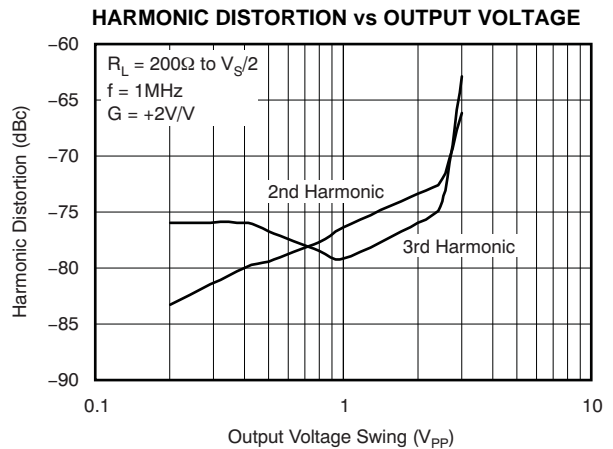

Figure 42.

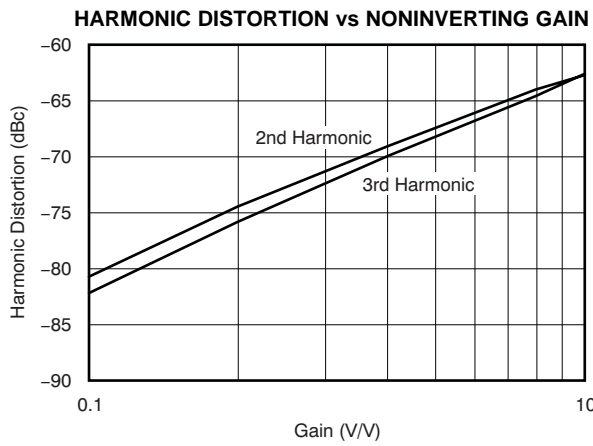

Figure 43.

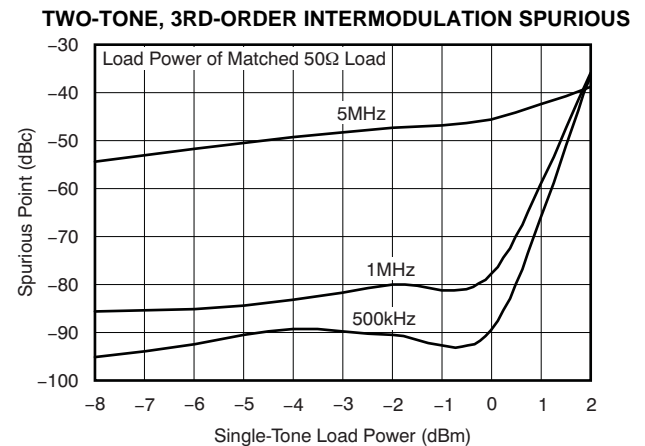

Figure 44.

TYPICAL CHARACTERISTICS: $V_S = +5V$, Differential

At $T_A = +25^\circ C$, Differential Gain = $+2V/V$, and $R_L = 200\Omega$, unless otherwise noted. See Figure 52.

DIFFERENTIAL SMALL-SIGNAL FREQUENCY RESPONSE

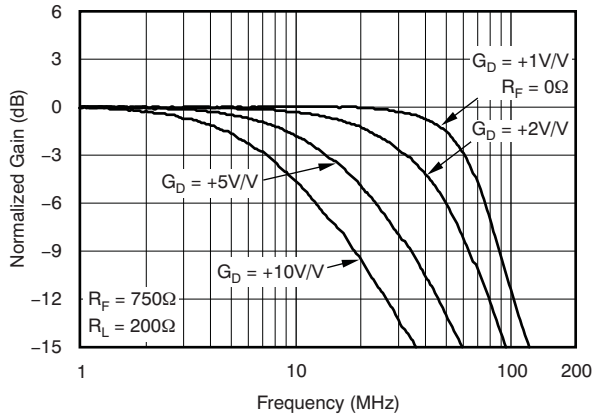

Figure 45.

DIFFERENTIAL LARGE-SIGNAL FREQUENCY RESPONSE

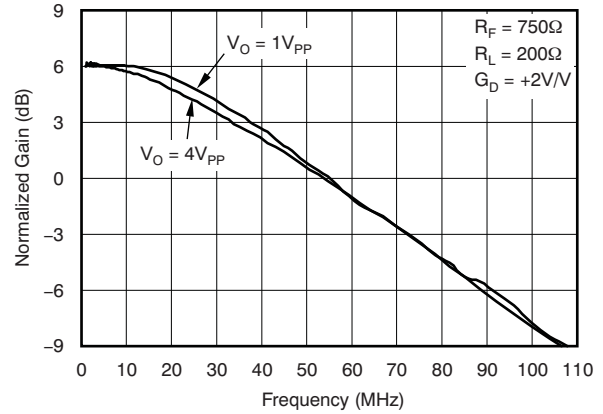

Figure 46.

DIFFERENTIAL DISTORTION vs LOAD RESISTANCE

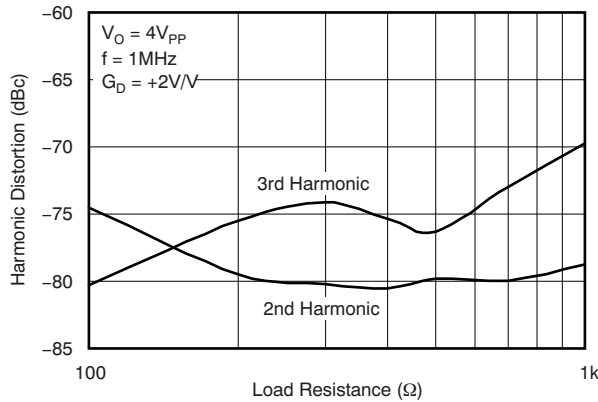

Figure 47.

DIFFERENTIAL DISTORTION vs FREQUENCY

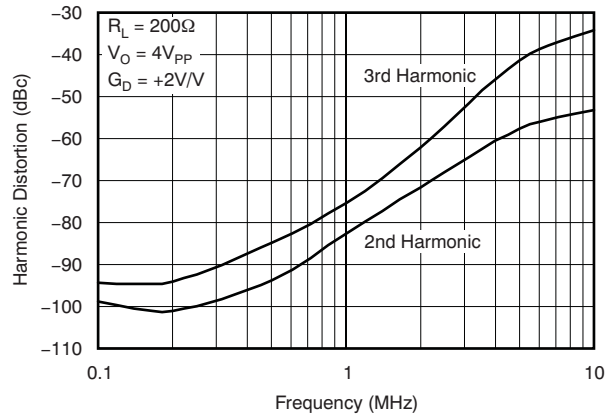

Figure 48.

DIFFERENTIAL DISTORTION vs OUTPUT VOLTAGE

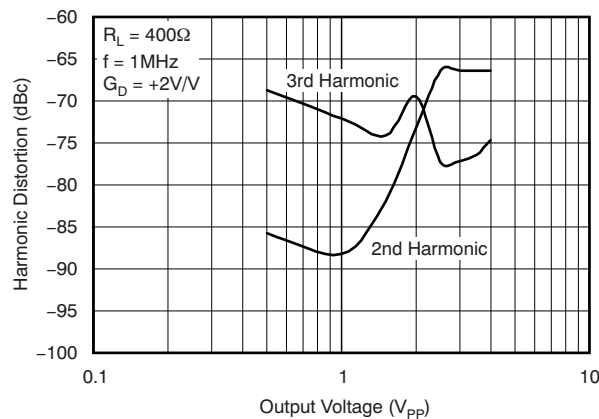

Figure 49.

APPLICATIONS INFORMATION

WIDEBAND VOLTAGE-FEEDBACK OPERATION

The OPA2889 provides an exceptional combination of high output power capability in a dual, wideband, unity-gain stable, voltage-feedback op amp using a new high slew rate input stage. Typical differential input stages used for voltage-feedback op amps are designed to steer a fixed-bias current to the compensation capacitor, setting a limit to the achievable slew rate. The OPA2889 uses a new input stage that places the transconductance element between two input buffers, using the output currents as the forward signal. As the error voltage increases across the two inputs, an increasing current is delivered to the compensation capacitor. This configuration provides high slew rate (250V/μs) while consuming very low quiescent current (460μA/ch). This exceptional full-power performance comes at the price of a slightly higher input noise voltage than alternative architectures. The 8.4nV/√Hz input voltage noise for the OPA2889 is exceptionally low for this type of input stage.

Figure 50 shows the dc-coupled, gain of +2V/V, dual power-supply circuit configuration used as the basis of the ±5V [Electrical Characteristics](#) and ±5V [Typical Characteristics](#). This illustration is for one channel; the other channel is connected similarly. For test purposes, the input impedance is set to 50Ω with a resistor to ground and the output impedance is set to 100Ω. Voltage swings reported in the [Electrical Characteristics](#) are taken directly at the input and output pins, while output powers (dBm) are at the matched 50Ω load. For the circuit of Figure 50, the total effective load will be 100Ω || 1.5kΩ. The disable control line (MSOP-10 package only) is typically left open for normal amplifier operation. Two optional components are included in Figure 50. An additional resistor (350Ω) is included in series with the noninverting input. Combined with the 25Ω dc source resistance looking back towards the signal generator, this resistor gives an input bias current cancelling resistance that matches the 375Ω source resistance seen at the inverting input (see the [DC Accuracy and Offset Control](#) section). In addition to the usual power-supply decoupling capacitors to ground, a 0.1μF capacitor is included between the two power-supply pins. In practical printed circuit board (PCB) layouts, this optional-added capacitor typically improves the 2nd-harmonic distortion performance by 3dB to 6dB.

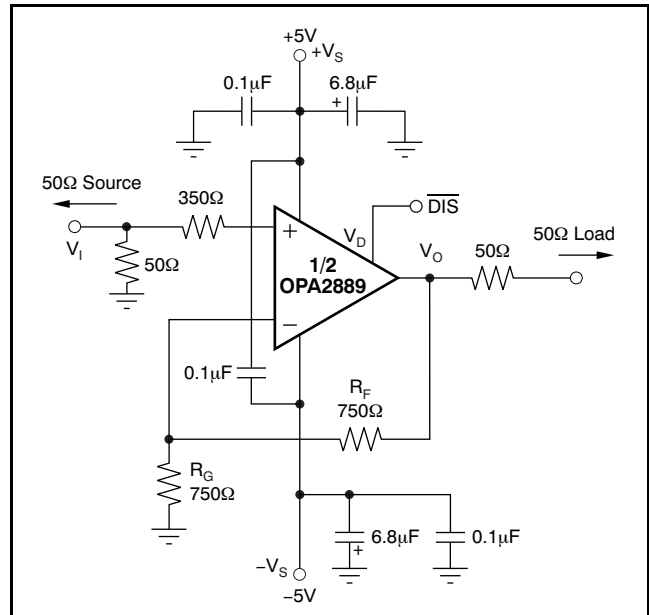

Figure 50. DC-Coupled, G = +2, Bipolar Supply, Specification and Test Circuit

Figure 51 illustrates the ac-coupled, gain of +2V/V, single-supply circuit configuration used as the basis of the +5V [Electrical Characteristics](#) and +5V [Typical Characteristics](#). Though not a rail-to-rail design, the OPA2889 requires minimal input and output voltage headroom compared to other very wideband voltage-feedback op amps. It delivers a 2.8V_{PP} output swing on a single +5V supply with > 50MHz bandwidth. The key requirement of broadband single-supply operation is to maintain input and output signal swings within the usable voltage ranges at both the input and the output. The circuit of Figure 51 establishes an input midpoint bias using a simple resistive divider from the +5V supply (two 698Ω resistors). Separate bias networks would be required at each input. The input signal is then ac-coupled into the midpoint voltage bias. The input voltage can swing to within 1.1V of either supply pin, giving a 2V_{PP} input signal range centered between the supply pins. The input impedance matching resistor (59Ω) used for testing is adjusted to give a 50Ω input load when the parallel combination of the biasing divider network is included.

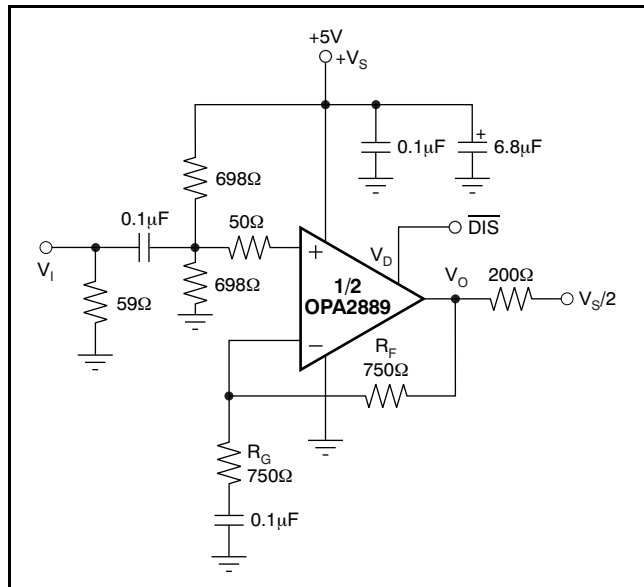

Figure 51. DC-Coupled, $G = +2$, Single-Supply, Specification and Test Circuit

Again, an additional resistor (50Ω in this case) is included directly in series with the noninverting input. This minimum recommended value provides part of the dc source resistance matching for the noninverting input bias current. It is also used to form a simple parasitic pole to roll off the frequency response at very high frequencies ($> 500\text{MHz}$) using the input parasitic capacitance. The gain resistor (R_G) is ac-coupled, giving the circuit a dc gain of +1, which puts the input dc bias voltage (2.5V) on the output as well. The output voltage can swing to within 1V of either supply pin while delivering $> 40\text{mA}$ output current.

DIFFERENTIAL OPERATION

Figure 52 shows the inverting input differential configuration used as the basis for the $\pm 5\text{V}$ and $+5\text{V}$ Typical Characteristics. This circuit offers a combination of excellent distortion with low quiescent current.

The other possibility is using the OPA2889 in a differential configuration as shown in Figure 53. This figure illustrates the differential noninverting input configuration which has the advantage of showing a high input impedance to any prior stage.

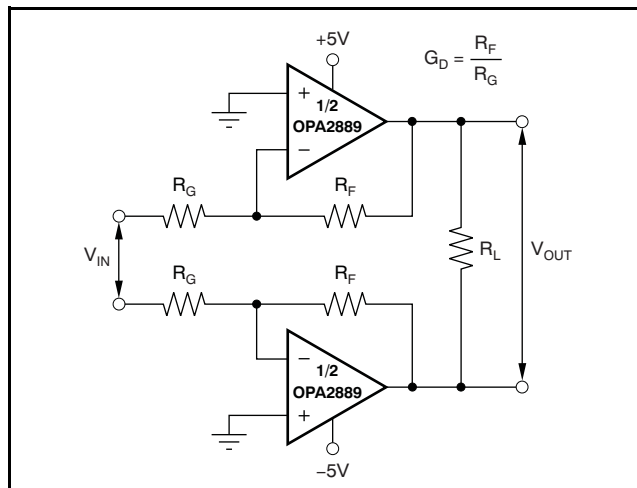

Figure 52. Differential Inverting Specification and Test Circuit

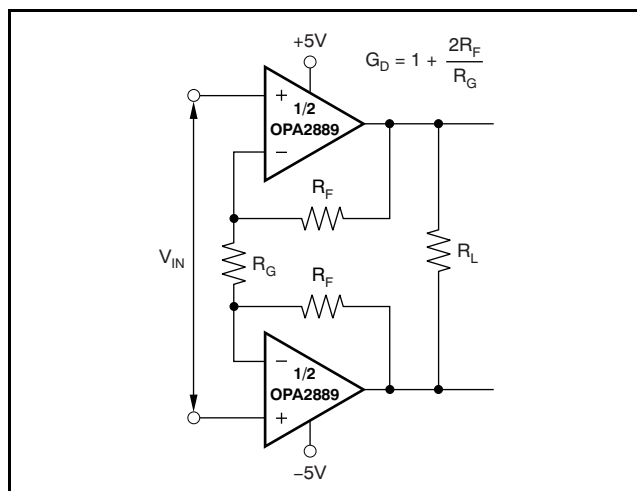

Figure 53. Differential Noninverting Specification and Test Circuit

HIGH-PERFORMANCE DAC TRANSIMPEDANCE AMPLIFIER

High-frequency DDS Digital-to-Analog Converters (DACs) require a low distortion output amplifier to retain their SFDR performance into real-world loads. Figure 54 shows a single-ended output drive implementation. The diagram shows the signal output current(s) connected into the virtual ground summing junction(s) of the OPA2889, which is set up as a transimpedance stage or I-V converter. If the DAC requires that its outputs terminate to a compliance voltage other than ground for operation, the appropriate voltage level may be applied to the noninverting input of the OPA2889. The dc gain for this circuit is equal to R_F . At high frequencies, the DAC output capacitance (C_D in Figure 54) produces a zero in the noise gain for the OPA2889 that may cause peaking in the closed-loop frequency response. C_F is added across R_F to compensate for this noise gain peaking. To achieve a flat transimpedance frequency response, the pole in each feedback network should be set to:

$$\frac{1}{2\pi R_F C_F} = \sqrt{\frac{GBP}{4\pi R_F C_D}} \tag{1}$$

which gives a cutoff frequency f_{-3dB} of approximately:

$$f_{-3dB} = \sqrt{\frac{GBP}{2\pi R_F C_D}} \tag{2}$$

WIDEBAND VIDEO MULTIPLEXING

One common application for video speed amplifiers that include a disable pin is to wire multiple amplifier outputs together, then select one of several possible video inputs to source onto a single line. This simple wired-OR video multiplexer can be easily implemented using the OP2889IDGS (MSOP-10 package only), as shown in Figure 55.

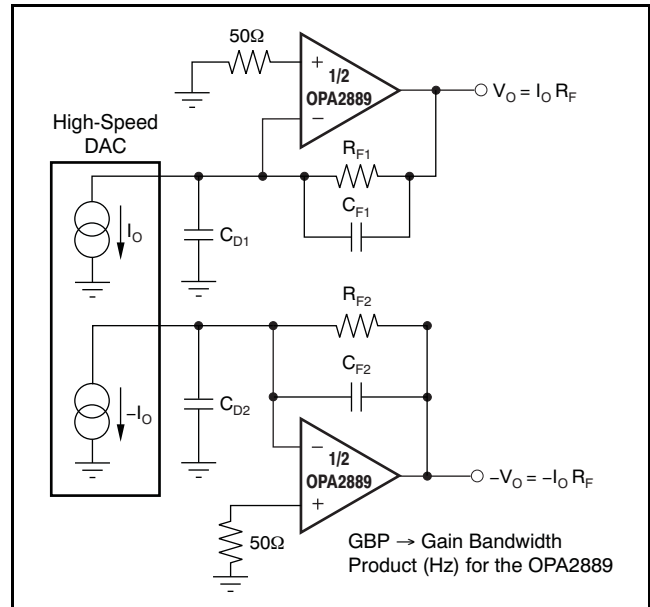

Figure 54. DAC Transimpedance Amplifier

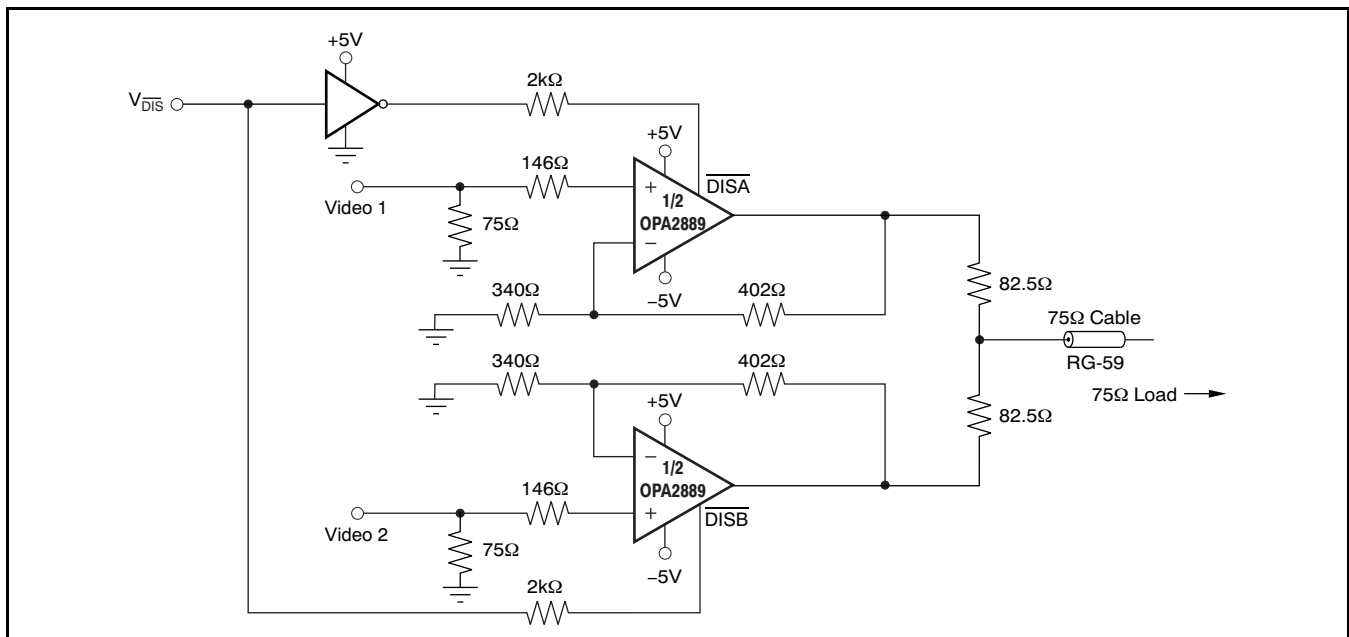

Figure 55. 2-Channel Video Multiplexer (SO-14 package only)

Typically, channel switching is performed either on sync or retrace time in the video signal. The two inputs are approximately equal at this point. The make-before-break disable characteristic of the OPA2889 ensures that there is always one amplifier controlling the line when using a wired-OR circuit like that shown in Figure 55. Because both inputs may be on for a short period during the transition between channels, the outputs are combined through the output impedance matching resistors (82.5Ω in this case). When one channel is disabled, its feedback network forms part of the output impedance and slightly attenuates the signal in getting out onto the cable. The gain and output matching resistor are slightly increased to get a signal gain of +1V/V at the matched load and provide a 75Ω output impedance to the cable. The video multiplexer connection (see Figure 55) also ensures that the maximum differential voltage across the inputs of the unselected channel does not exceed the rated ±1.2V maximum for standard video signal levels.

See the *Disable Operation* section for the turn-on and turn-off switching glitches using a 0V input for a single channel is typically less than ±50mV. Where two outputs are switched (see Figure 55), the output line is always under the control of one amplifier or the other as a result of the make-before-break disable timing. In this case, the switching glitches for two 0V inputs drops to < 20mV.

HIGH-SPEED DELAY CIRCUIT

The OPA2889 makes an ideal amplifier for a variety of active filter designs. Figure 56 illustrates a circuit that uses the two amplifiers within the dual OPA2889 to design a 2-stage analog delay circuit. For simplicity, the circuit uses a dual-supply (±5V) operation, but it can also be modified to operate on a signal supply. The input to the first filter stage is driven by the OPA890 as a gain of +2V/V to isolate the signal input from the filter network.

Each of the two filter stages is a 1st-order filter with a voltage gain of +1V/V. The delay time through one filter is given by Equation 3.

$$t_{GR0} = 2RC \quad (3)$$

For a more accurate analysis of the circuit, consider the group delay for the amplifiers. For example, in the case of the OPA2889, the group delay in the bandwidth from 1MHz to 100MHz is approximately 1.0ns. To account for this delay, modify the transfer function, which now comes out to be:

$$t_{GR} = 2(2RC + T_D) \quad (4)$$

with $T_D = (1/360) \times (d\phi/df) =$ delay of the op amp itself. The values of resistors R_F and R_G should be equal and low to avoid parasitic effects. If the all-pass filter is designed for very low delay times, include parasitic board capacitances to calculate the correct delay time. Simulating this application using the PSPICE model of the OPA2889 allows this design to be tuned to the desired performance.

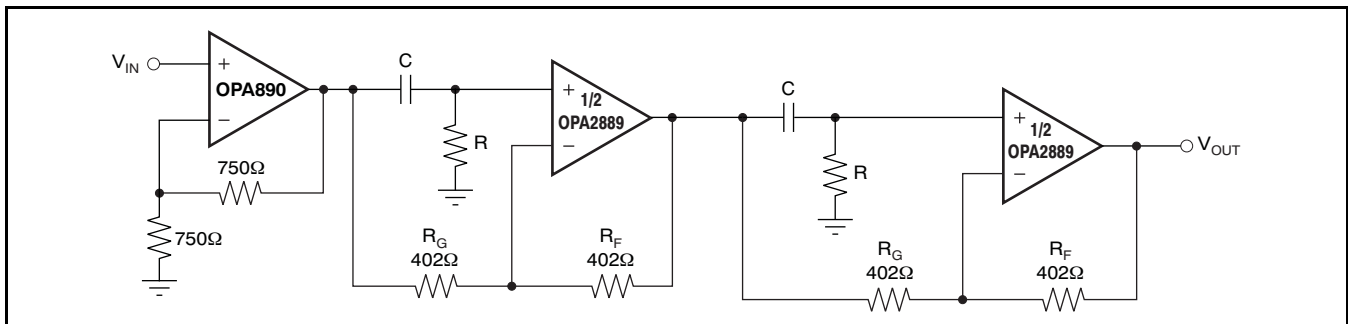

Figure 56. 2-Stage, All-Pass Network

DIFFERENTIAL RECEIVER/DRIVER

A very versatile application for a dual operational amplifier is the differential amplifier configuration shown in Figure 57. With both amplifiers of the OPA2889 connected for noninverting operation, the circuit provides a high input impedance whereas the gain can easily be set by just one resistor, R_G . When operated in low gains, the output swing may be limited as a result of the common-mode input swing limits of the amplifier itself. An interesting modification of this circuit is to place a capacitor in series with R_G . Now the dc gain for each side is reduced to $+1V/V$, whereas the ac gain still follows the standard transfer function of $G = 1 + 2R_F/R_G$. This might be advantageous for applications processing only a frequency band that excludes dc or very low frequencies. An input dc voltage resulting from input bias currents is not amplified by the ac gain and can be kept low. This circuit can be used as a differential line receiver, driver, or as an interface to a differential input ADC.

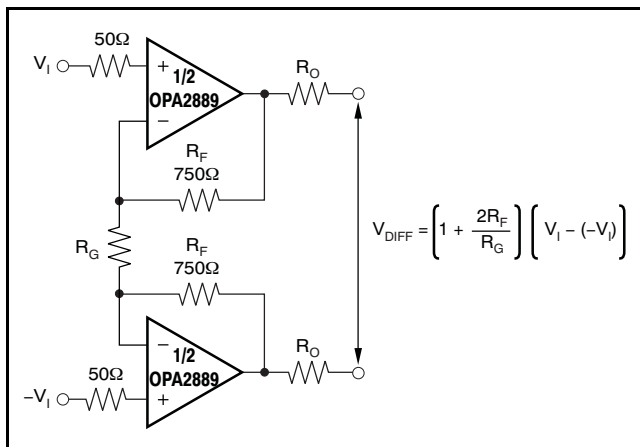

Figure 57. High-Speed Differential Receiver

SINGLE-SUPPLY MFB DIFFERENTIAL ACTIVE FILTER: 2MHz BUTTERWORTH CONFIGURATION

The active filter circuit illustrated in Figure 59 can be easily implemented using the OPA2889. In this configuration, each amplifier of the OPA2889 operates as an integrator. For this reason, this type of application is also called an *infinite gain filter* implementation. A Butterworth filter can be implemented using the following component ratios:

$$f_0 = \frac{1}{2 \times \pi \times R \times C}$$

$$R_1 = R_2 = 0.65 \times R$$

$$R_3 = 0.375 \times R$$

$$C_1 = C$$

$$C_2 = 2 \times C$$

The frequency response for a 2MHz Butterworth filter is shown in Figure 58. One advantage for using this type of filter is the independent setting of ω_0 and Q. Q can be easily adjusted by changing the $R_{3A, B}$ resistors without affecting ω_0 .

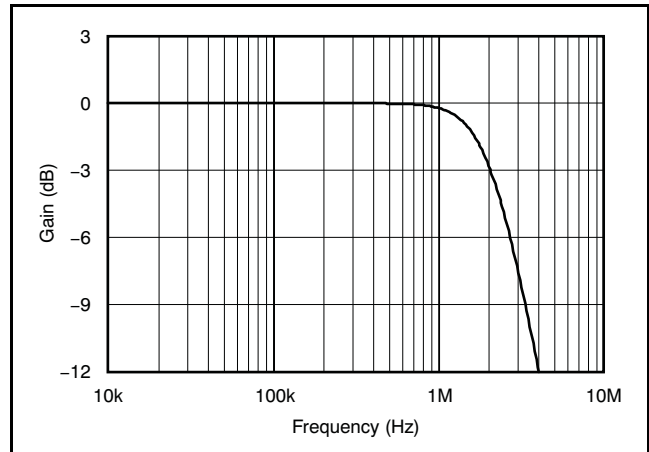

Figure 58. Multiple Feedback Filter Frequency Response

**LOW POWER, DC-COUPLED,
SINGLE-TO-DIFFERENTIAL DRIVER FOR
≤100kHz INPUT**

In systems where the input is differential (see front-page figure), the OPA2889 can be used in the inverting configuration with an additional dc bias applied to its positive input so as to keep the input to the ADS8472 within its rated operating voltage range. The dc bias can be derived from the REF3220 or the REF3240 reference voltage ICs. The input configuration shown on the front page of the data sheet is capable of delivering better than 100dB SNR and –100dBc THD at an input frequency of 200kHz. In case band-pass filters are used to filter the input, care should be taken to ensure that the signal swing at the input of the band-pass filter is small, so as to

minimize the distortion introduced by the filter. In such cases, the gain of the circuit shown on the front page of the data sheet can be increased to keep the input to the ADS8472 large in order to keep the SNR of the system high. Note that the gain of the system from the positive input to the output of the OPA2889 in such a configuration is a function of the ac signal gain. A resistor divider can be used to scale the output of the REF3220 or REF3240 to reduce the voltage at the dc input to OPA2889 to keep the voltage at the input of the converter within its rated operating range.

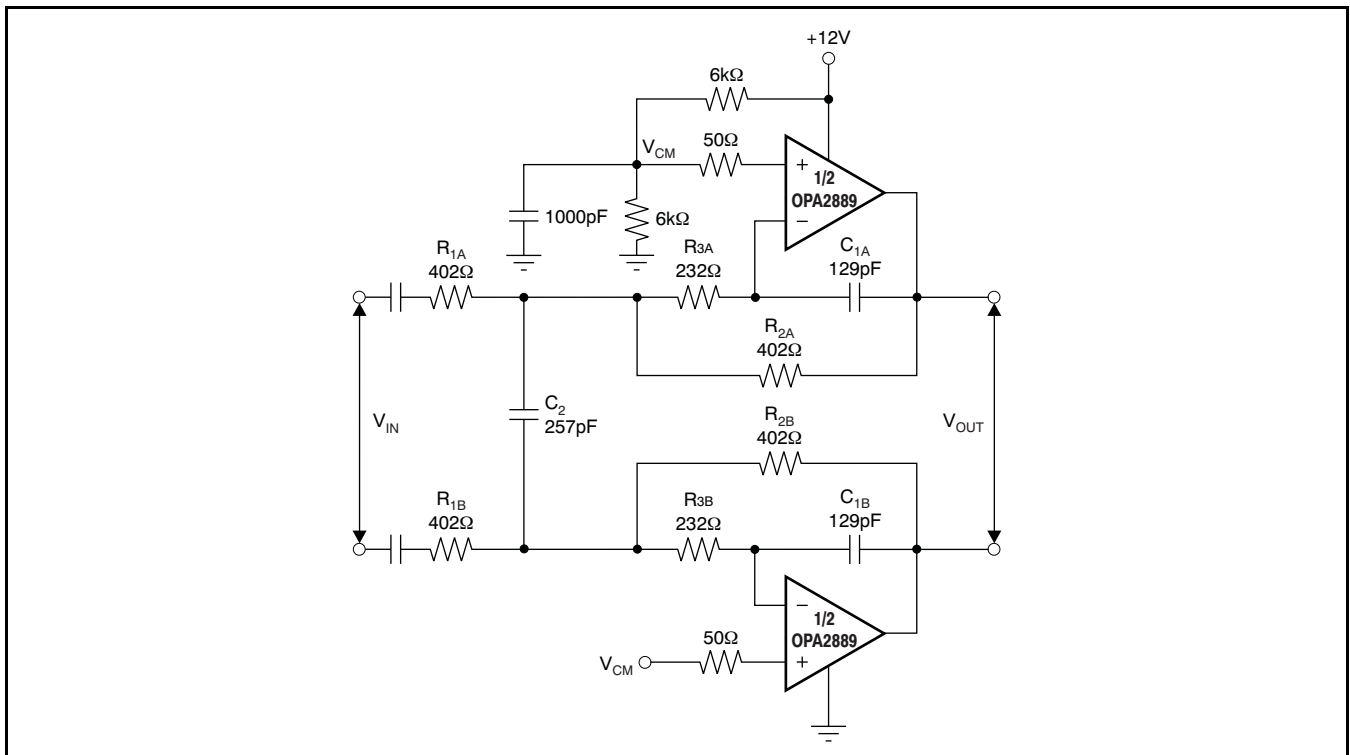

Figure 59. Single-Supply, MFB Active Filter, 2MHz LP Butterworth

DESIGN-IN TOOLS

DEMONSTRATION FIXTURES

Two printed circuit boards (PCBs) are available to assist in the initial evaluation of circuit performance using the OPA2889 in its two package options. Both of these are offered free of charge as unpopulated PCBs, delivered with a user's guide. The summary information for these fixtures is shown in [Table 1](#).

Table 1. Demonstration Fixtures by Package

PRODUCT	PACKAGE	ORDERING NUMBER	LITERATURE NUMBER
OPA2889ID	SO-8	DEM-OPA-SO-2A	SBOU003A
OPA2889IDGS	MSOP-10	DEM-OPA-MSOP-2B	SBOU040

The demonstration fixtures can be requested at the Texas Instruments web site (www.ti.com) through the OPA2889 product folder.

OPTIMIZING RESISTOR VALUES

Because the OPA2889 is a unity-gain stable, voltage-feedback op amp, a wide range of resistor values may be used for the feedback and gain setting resistors. The primary limits on these values are set by dynamic range (noise and distortion) and parasitic capacitance considerations. For a noninverting unity-gain follower application, the feedback connection should be made with a direct short. Usually, the feedback resistor value should be between 200 Ω and 1.5k Ω . Below 200 Ω , the feedback network presents additional output loading which can degrade the harmonic distortion performance of the OPA2889. Above 1.5k Ω , the typical parasitic capacitance (approximately 0.2pF) across the feedback resistor can cause unintentional band-limiting in the amplifier response.

A good rule of thumb is to target the parallel combination of R_F and R_G (see [Figure 50](#)) to be less than approximately 400 Ω . The combined impedance $R_F \parallel R_G$ interacts with the inverting input capacitance, placing an additional pole in the feedback network and thus, a zero in the forward response. Assuming a 2pF total parasitic on the inverting node, holding $R_F \parallel R_G < 400\Omega$ keeps this pole above 160MHz. By itself, this constraint implies that the feedback resistor R_F can increase to several k Ω at high gains. This increase in resistor size is acceptable as long as the pole formed by R_F and any parasitic capacitance appearing in parallel is kept out of the frequency range of interest.

MACROMODELS

Computer simulation of circuit performance using SPICE is often useful when analyzing the performance of analog circuits and systems. This principle is particularly true for video and RF amplifier circuits where parasitic capacitance and inductance can have a major effect on circuit performance. A SPICE model for the OPA2889 is available through the Texas Instruments web page (www.ti.com). This model does a good job of predicting small-signal ac and transient performance under a wide variety of operating conditions. It does not do as well in predicting the harmonic distortion or dG/dP characteristics. This model does not attempt to distinguish between the package types in their small-signal ac performance.

OPERATING RECOMMENDATIONS

BANDWIDTH vs GAIN: NONINVERTING OPERATION

Voltage-feedback op amps exhibit decreasing closed-loop bandwidth as the signal gain increases. In theory, this relationship is described by the Gain Bandwidth Product (GBP) shown in the [Electrical Characteristics](#). Ideally, dividing GBP by the noninverting signal gain (also called the Noise Gain, or NG) predicts the closed-loop bandwidth. In practice, this principle only holds true when the phase margin approaches 90°, as it does in high gain configurations. At low gains (increased feedback factors), most amplifiers exhibit a more complex response with lower phase margin. The OPA2889 is compensated to give a slightly peaked response in a noninverting gain of 2V/V (see [Figure 50](#)). This compensation results in a typical gain of +2V/V bandwidth of 60MHz, far exceeding that predicted by dividing the 75MHz GBP by 2. Increasing the gain causes the phase margin to approach 90° and the bandwidth to more closely approach the predicted value of (GBP/NG). At a gain of +10, the 8MHz bandwidth shown in the [Electrical Characteristics](#) agrees closely with that predicted using the simple formula and the typical GBP of 75MHz.

The frequency response in a gain of +2V/V may be modified to achieve exceptional flatness simply by increasing the noise gain to 2.5V/V. One way to modify the response without affecting the +2V/V signal gain, is to add a 750 Ω resistor across the two inputs, as shown in the circuit of [Figure 50](#). A similar technique may be used to reduce peaking in unity-gain (voltage follower) applications. For example, by using a 750 Ω feedback resistor along

with a 750Ω resistor across the two op amp inputs, the voltage follower response is similar to the gain of +2V/V response of Figure 51. Reducing the value of the resistor across the op amp inputs further limits the frequency response due to increased noise gain.

The OPA2889 exhibits minimal bandwidth reduction going to single-supply (+5V) operation as compared with ±5V. This behavior occurs because the internal bias control circuitry retains nearly constant quiescent current as the total supply voltage between the supply pins is changed.

INVERTING AMPLIFIER OPERATION

The OPA2889 is a general-purpose, wideband, voltage-feedback op amp; therefore, all of the familiar op amp application circuits are available to the designer. Inverting operation is one of the more common requirements and offers several performance benefits. See Figure 60 for a typical inverting configuration where the I/O impedances and signal gain from Figure 50 are retained in an inverting circuit configuration.

In the inverting configuration, three key design considerations must be noted. The first is that the gain resistor (R_G) becomes part of the signal channel input impedance. If input impedance matching is desired (which is beneficial whenever the signal is coupled through a cable, twisted-pair, long PCB trace, or other transmission line conductor), R_G may be set equal to the required termination value and R_F adjusted to give the desired gain. This consideration is the simplest approach and results in optimum bandwidth and noise performance. However, at low inverting gains, the resultant feedback resistor value can present a significant load to the amplifier output. For an inverting gain of $-2V/V$, setting R_G to 50Ω for input matching eliminates the need for R_M but requires a 100Ω feedback resistor. This approach has the interesting advantage that the noise gain becomes equal to $2V/V$ for a 50Ω source impedance—the same as the noninverting circuits considered in Figure 60. The amplifier output, however, now sees the 100Ω feedback resistor in parallel with the external load. In general, the feedback resistor should be limited to the 200Ω to 1.5kΩ range. In this case, it is preferable to increase both the R_F and R_G values (see Figure 60), and then achieve the input matching impedance with a third resistor (R_M) to ground. The total input impedance becomes the parallel combination of R_G and R_M .

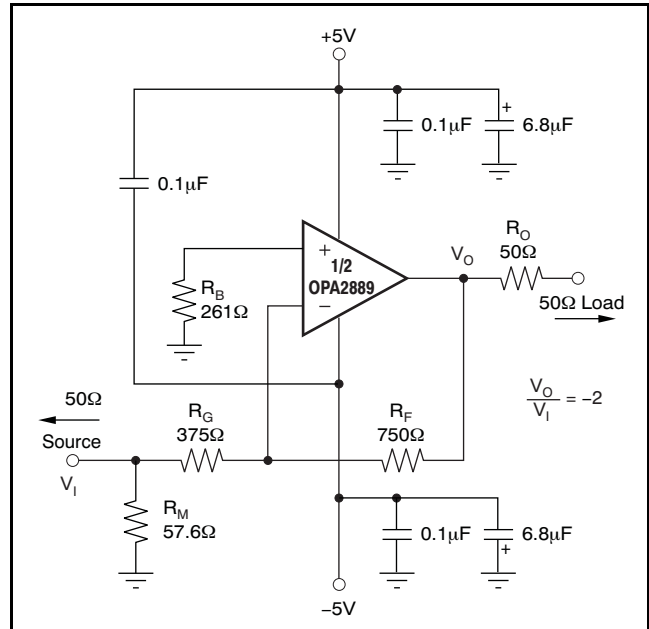

Figure 60. Gain of $-2V/V$ Example Circuit

The second major consideration, touched on in the previous paragraph, is that the signal source impedance becomes part of the noise gain equation and influences the bandwidth. For the example in Figure 60, the R_M value combined in parallel with the external 50Ω source impedance yields an effective source driving impedance of $50\Omega \parallel 57.6\Omega = 26.7\Omega$. This impedance is added in series with R_G for calculating the noise gain (NG). The resulting NG is $2.86V/V$ for Figure 60, as opposed to only $2V/V$ if R_M could be eliminated as discussed above. Therefore, the bandwidth is slightly lower for the gain of $-2V/V$ circuit of Figure 60 than for the gain of $+2V/V$ circuit of Figure 50.

The third important consideration in inverting amplifier design is setting the bias current cancellation resistor on the noninverting input (R_B). If this resistor is set equal to the total dc resistance looking out of the inverting node, the output dc error, as a result of the input bias currents, is reduced to $(\text{Input Offset Current}) \times R_F$. If the 50Ω source impedance is dc-coupled in Figure 60, the total resistance to ground on the inverting input is 402Ω.

Combining this resistance in parallel with the feedback resistor gives the $R_B = 261\Omega$ used in this example. To reduce the additional high-frequency noise introduced by this resistor, it is sometimes bypassed with a capacitor. As long as $R_B < 350\Omega$, the capacitor is not required because the total noise contribution of all other terms will be less than that of

the op amp input noise voltage. As a minimum, the OPA2889 requires an R_B value of 50Ω to damp out parasitic-induced peaking—a direct short to ground on the noninverting input runs the risk of a very high-frequency instability in the input stage.

DRIVING CAPACITIVE LOADS

One of the most demanding and yet very common load conditions for an op amp is capacitive loading. Often, the capacitive load is the input of an ADC—including additional external capacitance that may be recommended to improve ADC linearity. A high-speed, high open-loop gain amplifier such as the OPA2889 can be very susceptible to decreased stability and closed-loop response peaking when a capacitive load is placed directly on the output pin. When the open-loop output resistance of the amplifier is considered, this capacitive load introduces an additional pole in the signal path that can decrease the phase margin. Several external solutions to this problem have been suggested. When the primary considerations are frequency response flatness, pulse response fidelity, and/or distortion, the simplest and most effective solution is to isolate the capacitive load from the feedback loop by inserting a series-isolation resistor between the amplifier output and the capacitive load. This solution does not eliminate the pole from the loop response, but rather shifts it and adds a zero at a higher frequency. The additional zero acts to cancel the phase lag from the capacitive load pole, thus increasing the phase margin and improving stability.

The ± 5 [Typical Characteristics](#) show the recommended R_S versus capacitive load (see [Figure 15](#) and [Figure 16](#)) and the resulting frequency response at the load. Parasitic capacitive loads greater than 2pF can begin to degrade the performance of the OPA2889. Long PCB traces, unmatched cables, and connections to multiple devices can easily exceed this value. Always consider this effect carefully, and add the recommended series resistor as close as possible to the OPA2889 output pin (see the [Board Layout Guidelines](#) section).

DISTORTION PERFORMANCE

The OPA2889 provides good distortion performance into a 200Ω load on $\pm 5V$ supplies. Relative to alternative solutions, it provides exceptional performance into lighter loads and/or operating on a single +5V supply. Generally, until the fundamental signal reaches very high frequency or power levels, the 2nd-harmonic dominates the distortion with a negligible 3rd-harmonic component. Focusing then on the 2nd-harmonic, increasing the load impedance improves distortion directly. Remember that the total load includes the feedback network; in the noninverting configuration (see [Figure 50](#)), this total is the sum of $R_F + R_G$, while in the inverting configuration it is just R_F . Also, providing an additional supply-decoupling capacitor ($0.1\mu F$) between the supply pins (for bipolar operation) improves the 2nd-order distortion slightly (3dB to 6dB). Operating differentially also lowers 2nd-harmonic distortion terms (see the plot on the front page).

In most op amps, increasing the output voltage swing increases harmonic distortion directly. The output stage used in the OPA2889 actually holds the difference between fundamental power and the 2nd- and 3rd-harmonic powers relatively constant with increasing output power until very large output swings are required ($> 4V_{PP}$). This result also shows up in the 2-tone, 3rd-order intermodulation spurious (IM3) response curves. The 3rd-order spurious levels are extremely low at low output power levels. The output stage continues to hold them low even as the fundamental power reaches very high levels. As the [Typical Characteristics](#) show, the spurious intermodulation powers do not increase as predicted by a traditional intercept model. As the fundamental power level increases, the dynamic range does not decrease significantly. For two tones centered at 1MHz, with 4dBm/tone into a matched 50Ω load (that is, $1V_{PP}$ for each tone at the load, which requires $4V_{PP}$ for the overall 2-tone envelope at the output pin), the [Typical Characteristics](#) show $-73dBc$ difference between the test tone powers and the 3rd-order intermodulation spurious powers. This performance is exceptional for an amplifier with only 4.6mW of internal power dissipation.

NOISE PERFORMANCE

High slew rate, unity-gain stable, voltage-feedback op amps usually achieve the slew rate at the expense of a higher input noise voltage. However, the 8.4nV/√Hz input voltage noise for the OPA2889 is much lower than that of comparable amplifiers. The input-referred voltage noise, and the two input-referred current noise terms, combine to give low output noise under a wide variety of operating conditions. Figure 61 shows the op amp noise analysis model with all the noise terms included. In this model, all noise terms are taken to be noise voltage or current density terms in either nV/√Hz or pA/√Hz.

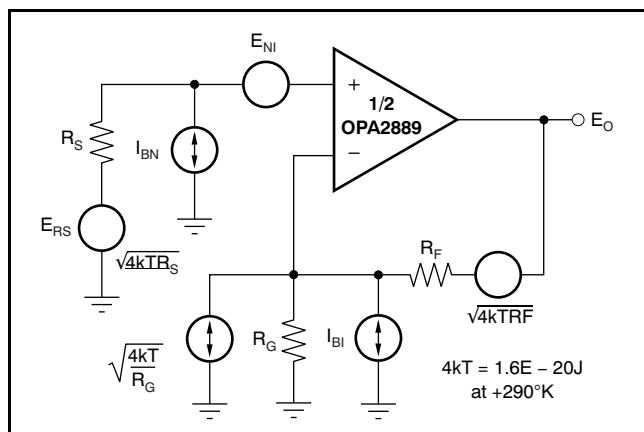

Figure 61. Op Amp Noise Analysis Model

The total output spot noise voltage can be computed as the square root of the sum of all squared output noise voltage contributors. Equation 5 shows the general form for the output noise voltage using the terms shown in Figure 61.

$$E_O = \sqrt{[E_{NI}^2 + (I_{BN}R_S)^2 + 4kTR_S]NG^2 + (I_{BI}R_F)^2 + 4kTR_FNG} \quad (5)$$

Dividing this expression by the noise gain ($NG = (1 + R_F/R_G)$) gives the equivalent input-referred spot noise voltage at the noninverting input, as shown in Equation 6.

$$E_N = \sqrt{E_{NI}^2 + (I_{BN}R_S)^2 + 4kTR_S + \left(\frac{I_{BI}R_F}{NG}\right)^2 + \frac{4kTR_F}{NG}} \quad (6)$$

Evaluating these two equations for the OPA2889 circuit and component values (see Figure 50) gives a total output spot noise voltage of 18.2nV/√Hz and a total equivalent input spot noise voltage of 9.1nV/√Hz. This total includes the noise added by the bias current cancellation resistor (350Ω) on the noninverting input. This total input-referred spot noise voltage is slightly higher than the 8nV/√Hz specification for the op amp voltage noise alone. This result is the case as long as the impedances appearing at each op amp input are limited to the

previously recommend maximum value of 400Ω. Keeping both ($R_F \parallel R_G$) and the noninverting input source impedance less than 400Ω satisfies both noise and frequency response flatness considerations. Because the resistor-induced noise is relatively negligible, additional capacitive decoupling across the bias current cancellation resistor (R_B) for the inverting op amp configuration of Figure 60 is not required.

DC ACCURACY AND OFFSET CONTROL

The balanced input stage of a wideband voltage-feedback op amp allows good output dc accuracy in a wide variety of applications. The power-supply current trim for the OPA2889 gives even tighter control than comparable amplifiers. Although the high-speed input stage does require relatively low $\pm 0.75\mu\text{A}$ input bias current, the close matching between them may be used to reduce the output dc error caused by this current. The total output offset voltage may be reduced by matching the dc source resistances appearing at the two inputs. This matching reduces the output dc error resulting from the input bias currents to the offset current times the feedback resistor. Evaluating the configuration of Figure 50, and using worst-case +25°C input offset voltage and current specifications, gives a worst-case output offset voltage equal to:

$$\begin{aligned} &\pm(NG \times V_{OS(\text{MAX})}) \pm (R_F \times I_{OS(\text{MAX})}) \\ &= \pm(2 \times 5\text{mV}) \pm (750\Omega \times 0.75\mu\text{A}) \\ &= \pm 10.6\text{mV with } -(NG = \text{noninverting signal gain}) \end{aligned}$$

A fine-scale output offset null, or dc operating point adjustment, is often required. Numerous techniques are available for introducing dc offset control into an op amp circuit. Most of these techniques eventually reduce to adding a dc current through the feedback resistor. In selecting an offset trim method, one key consideration is the impact on the desired signal path frequency response. If the signal path is intended to be noninverting, the offset control is best applied as an inverting summing signal to avoid interaction with the signal source. If the signal path is intended to be inverting, applying the offset control to the noninverting input may be considered. However, the dc offset voltage on the summing junction sets up a dc current back into the source that must be considered. Applying an offset adjustment to the inverting op amp input can change the noise gain and frequency response flatness. For a dc-coupled inverting amplifier, Figure 62 shows one example of an offset adjustment technique that has minimal impact on the signal frequency response. In this case, the dc offsetting current is brought into the

inverting input node through resistor values that are much larger than the signal path resistors. This technique ensures that the adjustment circuit has minimal effect on the loop gain and thus, the frequency response.

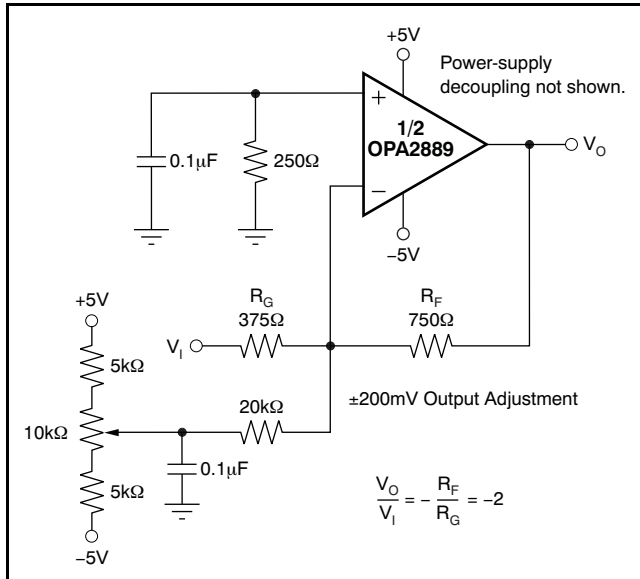

Figure 62. DC-Coupled, Inverting Gain of $-2V/V$, with Offset Adjustment

DISABLE OPERATION (MSOP-10 Package Only)

The OPA2889IDGS provides an optional disable feature that can be used either to reduce system power or to implement a simple channel multiplexing operation. If the \overline{DIS} control pin is left unconnected, the OPA2889IDGS operates normally. To disable, the control pin must be asserted LOW. Figure 63 shows a simplified internal circuit for the disable control feature.

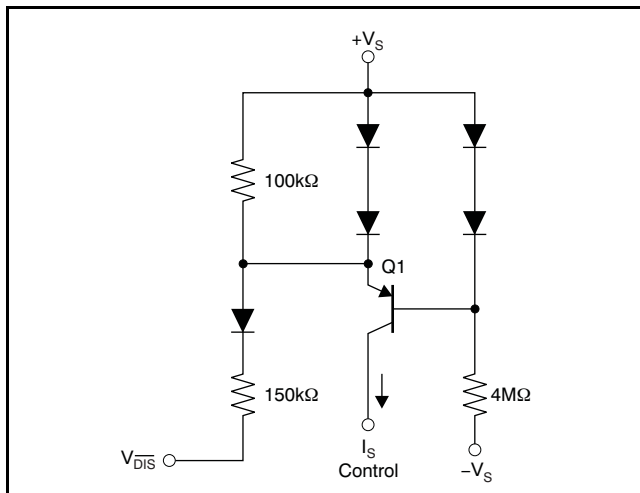

Figure 63. Simplified Disable Control Circuit

In normal operation, base current to Q1 is provided through the $4M\Omega$ resistor, while the emitter current through the $100k\Omega$ resistor sets up a voltage drop that is inadequate to turn on the two diodes in the Q1 emitter. As $\overline{V_{DIS}}$ is pulled LOW, additional current is pulled through the $100k\Omega$ resistor, eventually turning on those two diodes ($\approx 18\mu A$). At this point, any further current pulled out of $\overline{V_{DIS}}$ goes through those diodes holding the emitter-base voltage of Q1 at approximately 0V. This current shuts off the collector current out of Q1, turning the amplifier off. The supply currents in the disable mode are only those required to operate the circuit of Figure 63. Additional circuitry ensures that turn-on time occurs faster than turn-off time (make-before-break).

When disabled, the output and input nodes go to a high-impedance state. If the OPA2889 is operating at a gain of $+1V/V$, the device shows a very high impedance at the output and exceptional signal isolation. If operating at a gain greater than $+1V/V$, the total feedback network resistance ($R_F + R_G$) appears as the impedance looking back into the output, but the circuit still shows very high forward and reverse isolation. If configured as an inverting amplifier, the input and output are connected through the feedback network resistance ($R_F + R_G$) and the isolation will be very poor as a result.

THERMAL ANALYSIS

Maximum desired junction temperature sets the maximum allowed internal power dissipation as described below. In no case should the maximum junction temperature be allowed to exceed $+150^\circ C$.

Operating junction temperature (T_J) is given by $T_A + P_D \times \theta_{JA}$. The total internal power dissipation (P_D) is the sum of quiescent power (P_{DQ}) and additional power dissipated in the output stage (P_{DL}) to deliver load power. Quiescent power is simply the specified no-load supply current times the total supply voltage across the part. P_{DL} depends on the required output signal and load; for a grounded resistive load, P_{DL} is at a maximum when the output is fixed at a voltage equal to $1/2$ of either supply voltage (for equal bipolar supplies). Under this condition, $P_{DL} = V_S^2 / (4 \times R_L)$, where R_L includes feedback network loading.

Note that it is the power in the output stage and not into the load that determines internal power dissipation.

As a worst-case example, compute the maximum T_J using an OPA2889ID (SO-8 package) in the circuit of [Figure 50](#) operating at the maximum specified ambient temperature of +85°C and with both outputs driving a grounded 75Ω load to +2.5V.

$$P_D = 10V \times 2.5mA + 2[5^2 / (4 \times (75\Omega \parallel 1.5k\Omega))] = 200mW$$

$$\text{Maximum } T_J = +85^\circ\text{C} + (200mW \times 125^\circ\text{C/W}) = +110^\circ\text{C}$$

This absolute worst-case condition does not exceed the specified maximum junction temperature. Actual P_{DL} is normally less than that considered here. Carefully consider maximum T_J in your application.

BOARD LAYOUT GUIDELINES

Achieving optimum performance with a high-frequency amplifier like the OPA2889 requires careful attention to board layout parasitics and external component types. Recommendations that optimize performance include:

a) Minimize parasitic capacitance to any ac ground for all of the signal I/O pins. Parasitic capacitance on the output and inverting input pins can cause instability: on the noninverting input, it can react with the source impedance to cause unintentional bandlimiting. To reduce unwanted capacitance, a window around the signal I/O pins should be opened in all of the ground and power planes around those pins. Otherwise, ground and power planes should be unbroken elsewhere on the board.

b) Minimize the distance (< 0.25") from the power-supply pins to high-frequency 0.1μF decoupling capacitors. At the device pins, the ground and power-plane layout should not be in close proximity to the signal I/O pins. Avoid narrow power and ground traces to minimize inductance between the pins and the decoupling capacitors. The power-supply connections should always be decoupled with these capacitors. An optional supply decoupling capacitor (0.1μF) across the two power supplies (for bipolar operation) improves 2nd-harmonic distortion performance. Larger (2.2μF to 6.8μF) decoupling capacitors, effective at lower frequencies, should also be used on the main supply pins. These capacitors may be placed somewhat farther from the device and may be shared among several devices in the same area of the printed circuit board (PCB).

c) Careful selection and placement of external components preserves the high-frequency performance of the OPA2889. Resistors should be a very low reactance type. Surface-mount resistors work best and allow a tighter overall layout. Metal film or carbon composition axially-leaded resistors can also provide good high-frequency performance.

Again, keep the leads and PCB traces as short as possible. Never use wirewound type resistors in a high-frequency application. Since the output pin and inverting input pin are the most sensitive to parasitic capacitance, always position the feedback and series output resistor, if any, as close as possible to the output pin. Other network components, such as noninverting input termination resistors, should also be placed close to the package. Even with a low parasitic capacitance shunting the external resistors, excessively high resistor values can create significant time constants that can degrade performance. Good axial metal film or surface-mount resistors have approximately 0.2pF in shunt with the resistor. For resistor values > 1.5kΩ, this parasitic capacitance can add a pole and/or zero below 500MHz that can effect circuit operation. Keep resistor values as low as possible consistent with load driving considerations. The 75Ω feedback used in the [Electrical Characteristics](#) is a good starting point for design. Note that a 0Ω feedback resistor is suggested for the unity-gain follower application.

d) Connections to other wideband devices on the board may be made with short, direct traces or through onboard transmission lines. For short connections, consider the trace and the input to the next device as a lumped capacitive load. Relatively wide traces (50mils to 100mils) should be used, preferably with ground and power planes opened up around them. Estimate the total capacitive load and set R_S from the plots of [Figure 15](#) and [Figure 16](#). Low parasitic capacitive loads (< 3pF) may not need an R_S because the OPA2889 is nominally compensated to operate with a 2pF parasitic load. Higher parasitic capacitive loads without an R_S are allowed as the signal gain increases (increasing the unloaded phase margin; see [Figure 24](#)). If a long trace is required, and the 6dB signal loss intrinsic to a doubly-terminated transmission line is acceptable, implement a matched impedance transmission line using microstrip or stripline techniques (consult an ECL design handbook for microstrip and stripline layout techniques). A 50Ω environment is normally not necessary on board, and in fact, a higher impedance environment improves distortion as shown in the distortion versus load plots. With a characteristic board trace impedance defined (based on board material and trace dimensions), a matching series resistor into the trace from the output of the OPA2889 is used as well as a terminating shunt resistor at the input of the destination device. Remember also that the terminating impedance is the parallel combination of the shunt resistor and the input impedance of the destination device; this total effective impedance should be set to match the trace impedance.

e) Socketing a high-speed part like the OPA2889 is not recommended. The additional lead length and pin-to-pin capacitance introduced by the socket can create an extremely troublesome parasitic network that can make it almost impossible to achieve a smooth, stable frequency response. Best results are obtained by soldering the OPA2889 onto the board.

INPUT AND ESD PROTECTION

The OPA2889 is built using a very high-speed complementary bipolar process. The internal junction breakdown voltages are relatively low for these very small geometry devices. These breakdowns are reflected in the [Absolute Maximum Ratings](#) table. All device pins are protected with internal ESD protection diodes to the power supplies, as shown in [Figure 64](#).

These diodes provide moderate protection to input overdrive voltages above the supplies as well. The

protection diodes can typically support 30mA continuous current. Where higher currents are possible (for example, in systems with $\pm 15\text{V}$ supply parts driving into the OPA2889), current-limiting series resistors should be added into the two inputs. Keep these resistor values as low as possible since high values degrade both noise performance and frequency response.

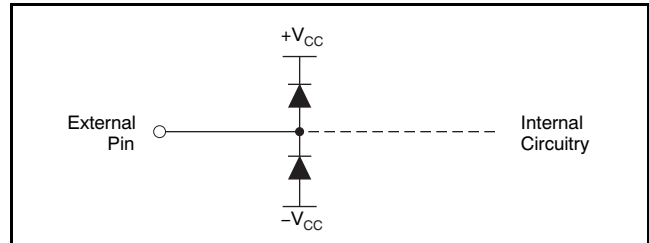

Figure 64. Internal ESD Protection

Revision History

Changes from Revision A (September 2007) to Revision B	Page
<ul style="list-style-type: none">Changed storage temperature range rating in <i>Absolute Maximum Ratings</i> table from -40°C to $+125^{\circ}\text{C}$ to -65°C to $+125^{\circ}\text{C}$	2

PACKAGING INFORMATION

Orderable Device	Status (1)	Package Type	Package Drawing	Pins	Package Qty	Eco Plan (2)	Lead/Ball Finish (6)	MSL Peak Temp (3)	Op Temp (°C)	Device Marking (4/5)	Samples
OPA2889ID	ACTIVE	SOIC	D	8	75	Green (RoHS & no Sb/Br)	CU NIPDAU	Level-2-260C-1 YEAR		OP2889	Samples
OPA2889IDGSR	ACTIVE	VSSOP	DGS	10	2500	Green (RoHS & no Sb/Br)	CU NIPDAUAG	Level-2-260C-1 YEAR	-40 to 85	BZY	Samples
OPA2889IDGST	ACTIVE	VSSOP	DGS	10	250	Green (RoHS & no Sb/Br)	CU NIPDAUAG	Level-2-260C-1 YEAR		BZY	Samples
OPA2889IDGSTG4	ACTIVE	VSSOP	DGS	10	250	Green (RoHS & no Sb/Br)	CU NIPDAUAG	Level-2-260C-1 YEAR	-40 to 85	BZY	Samples
OPA2889IDR	ACTIVE	SOIC	D	8	2500	Green (RoHS & no Sb/Br)	CU NIPDAU	Level-2-260C-1 YEAR	-40 to 85	OP2889	Samples

(1) The marketing status values are defined as follows:

ACTIVE: Product device recommended for new designs.

LIFEBUY: TI has announced that the device will be discontinued, and a lifetime-buy period is in effect.

NRND: Not recommended for new designs. Device is in production to support existing customers, but TI does not recommend using this part in a new design.

PREVIEW: Device has been announced but is not in production. Samples may or may not be available.

OBSOLETE: TI has discontinued the production of the device.

(2) **RoHS:** TI defines "RoHS" to mean semiconductor products that are compliant with the current EU RoHS requirements for all 10 RoHS substances, including the requirement that RoHS substance do not exceed 0.1% by weight in homogeneous materials. Where designed to be soldered at high temperatures, "RoHS" products are suitable for use in specified lead-free processes. TI may reference these types of products as "Pb-Free".

RoHS Exempt: TI defines "RoHS Exempt" to mean products that contain lead but are compliant with EU RoHS pursuant to a specific EU RoHS exemption.

Green: TI defines "Green" to mean the content of Chlorine (Cl) and Bromine (Br) based flame retardants meet JS709B low halogen requirements of <=1000ppm threshold. Antimony trioxide based flame retardants must also meet the <=1000ppm threshold requirement.

(3) MSL, Peak Temp. - The Moisture Sensitivity Level rating according to the JEDEC industry standard classifications, and peak solder temperature.

(4) There may be additional marking, which relates to the logo, the lot trace code information, or the environmental category on the device.

(5) Multiple Device Markings will be inside parentheses. Only one Device Marking contained in parentheses and separated by a "-" will appear on a device. If a line is indented then it is a continuation of the previous line and the two combined represent the entire Device Marking for that device.

(6) Lead/Ball Finish - Orderable Devices may have multiple material finish options. Finish options are separated by a vertical ruled line. Lead/Ball Finish values may wrap to two lines if the finish value exceeds the maximum column width.

Important Information and Disclaimer: The information provided on this page represents TI's knowledge and belief as of the date that it is provided. TI bases its knowledge and belief on information provided by third parties, and makes no representation or warranty as to the accuracy of such information. Efforts are underway to better integrate information from third parties. TI has taken and continues to take reasonable steps to provide representative and accurate information but may not have conducted destructive testing or chemical analysis on incoming materials and chemicals. TI and TI suppliers consider certain information to be proprietary, and thus CAS numbers and other limited information may not be available for release.

In no event shall TI's liability arising out of such information exceed the total purchase price of the TI part(s) at issue in this document sold by TI to Customer on an annual basis.

TAPE AND REEL INFORMATION



QUADRANT ASSIGNMENTS FOR PIN 1 ORIENTATION IN TAPE



*All dimensions are nominal

Device	Package Type	Package Drawing	Pins	SPQ	Reel Diameter (mm)	Reel Width W1 (mm)	A0 (mm)	B0 (mm)	K0 (mm)	P1 (mm)	W (mm)	Pin1 Quadrant
OPA2889IDGSR	VSSOP	DGS	10	2500	330.0	12.4	5.3	3.4	1.4	8.0	12.0	Q1
OPA2889IDGST	VSSOP	DGS	10	250	180.0	12.4	5.3	3.4	1.4	8.0	12.0	Q1
OPA2889IDR	SOIC	D	8	2500	330.0	12.4	6.4	5.2	2.1	8.0	12.0	Q1

TAPE AND REEL BOX DIMENSIONS

*All dimensions are nominal

Device	Package Type	Package Drawing	Pins	SPQ	Length (mm)	Width (mm)	Height (mm)
OPA2889IDGSR	VSSOP	DGS	10	2500	367.0	367.0	35.0
OPA2889IDGST	VSSOP	DGS	10	250	210.0	185.0	35.0
OPA2889IDR	SOIC	D	8	2500	367.0	367.0	35.0

DGS0010A

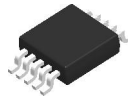

PACKAGE OUTLINE

VSSOP - 1.1 mm max height

SMALL OUTLINE PACKAGE

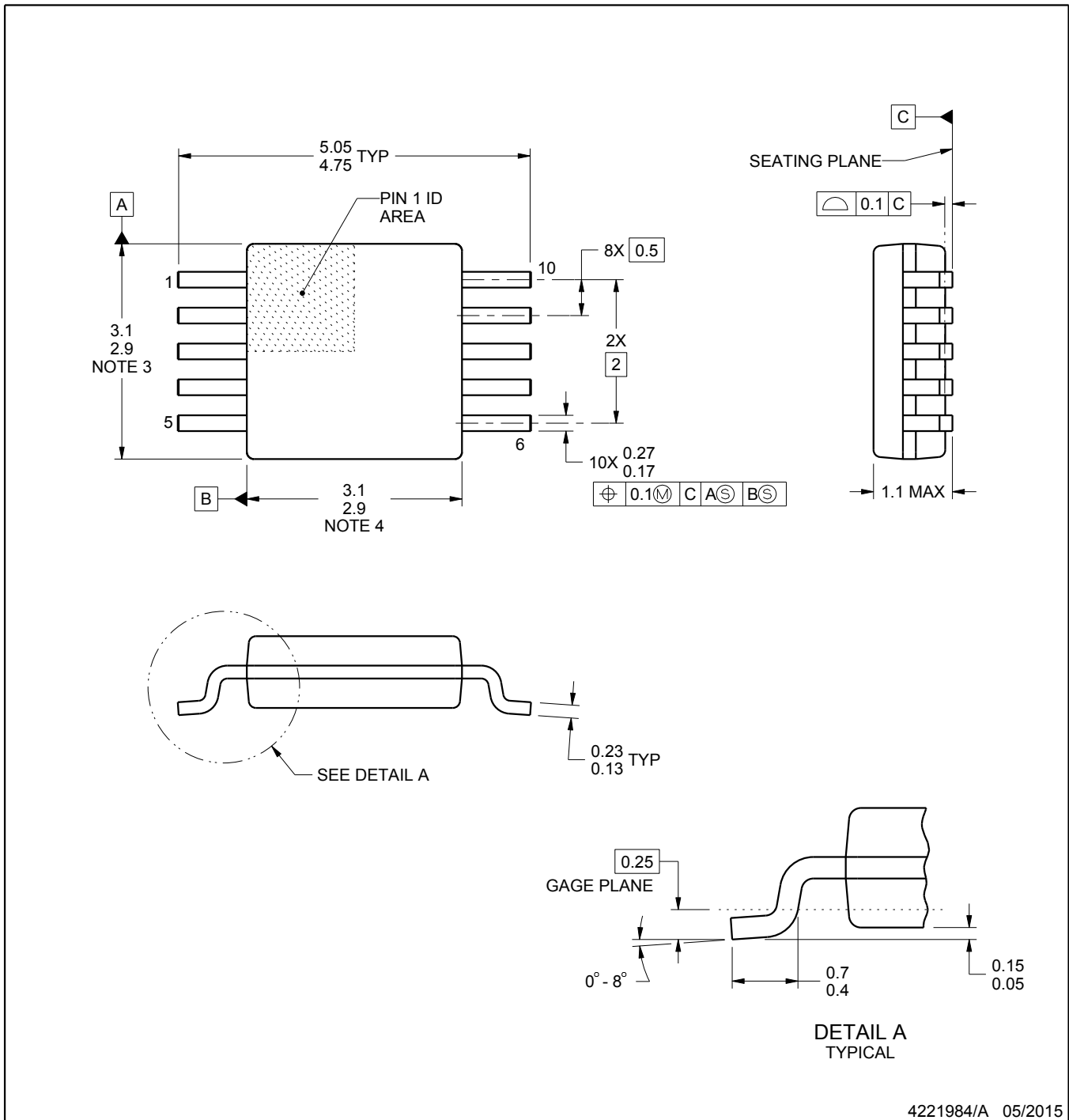

4221984/A 05/2015

NOTES:

1. All linear dimensions are in millimeters. Any dimensions in parenthesis are for reference only. Dimensioning and tolerancing per ASME Y14.5M.
2. This drawing is subject to change without notice.
3. This dimension does not include mold flash, protrusions, or gate burrs. Mold flash, protrusions, or gate burrs shall not exceed 0.15 mm per side.
4. This dimension does not include interlead flash. Interlead flash shall not exceed 0.25 mm per side.
5. Reference JEDEC registration MO-187, variation BA.

EXAMPLE BOARD LAYOUT

DGS0010A

VSSOP - 1.1 mm max height

SMALL OUTLINE PACKAGE



LAND PATTERN EXAMPLE
SCALE:10X

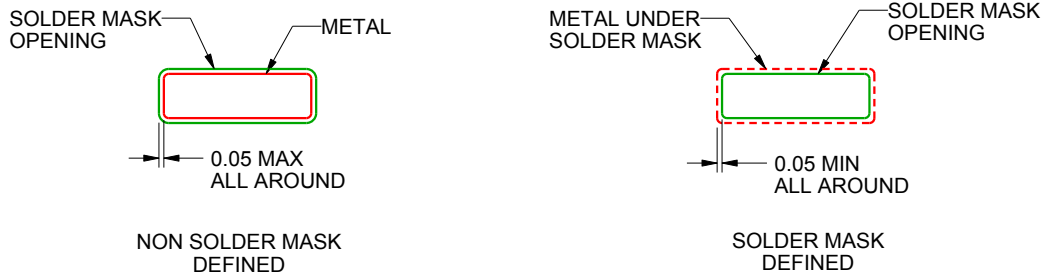

SOLDER MASK DETAILS
NOT TO SCALE

4221984/A 05/2015

NOTES: (continued)

6. Publication IPC-7351 may have alternate designs.
7. Solder mask tolerances between and around signal pads can vary based on board fabrication site.

EXAMPLE STENCIL DESIGN

DGS0010A

VSSOP - 1.1 mm max height

SMALL OUTLINE PACKAGE



SOLDER PASTE EXAMPLE
BASED ON 0.125 mm THICK STENCIL
SCALE:10X

4221984/A 05/2015

NOTES: (continued)

8. Laser cutting apertures with trapezoidal walls and rounded corners may offer better paste release. IPC-7525 may have alternate design recommendations.
9. Board assembly site may have different recommendations for stencil design.



D0008A

PACKAGE OUTLINE

SOIC - 1.75 mm max height

SMALL OUTLINE INTEGRATED CIRCUIT

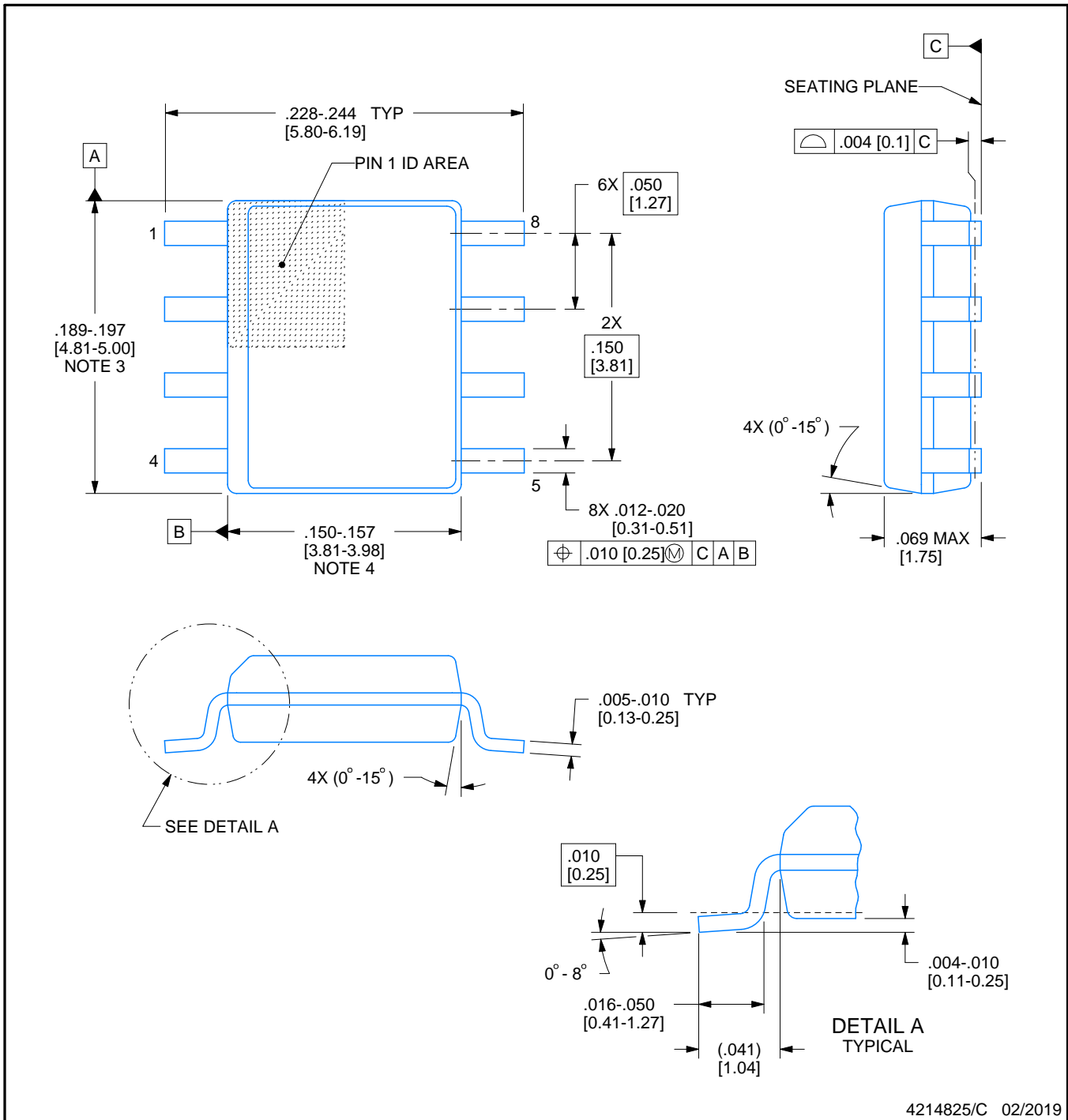

4214825/C 02/2019

NOTES:

- Linear dimensions are in inches [millimeters]. Dimensions in parenthesis are for reference only. Controlling dimensions are in inches. Dimensioning and tolerancing per ASME Y14.5M.
- This drawing is subject to change without notice.
- This dimension does not include mold flash, protrusions, or gate burrs. Mold flash, protrusions, or gate burrs shall not exceed $.006$ [0.15] per side.
- This dimension does not include interlead flash.
- Reference JEDEC registration MS-012, variation AA.

EXAMPLE BOARD LAYOUT

D0008A

SOIC - 1.75 mm max height

SMALL OUTLINE INTEGRATED CIRCUIT



LAND PATTERN EXAMPLE
 EXPOSED METAL SHOWN
 SCALE:8X



SOLDER MASK DETAILS

4214825/C 02/2019

NOTES: (continued)

- 6. Publication IPC-7351 may have alternate designs.
- 7. Solder mask tolerances between and around signal pads can vary based on board fabrication site.

EXAMPLE STENCIL DESIGN

D0008A

SOIC - 1.75 mm max height

SMALL OUTLINE INTEGRATED CIRCUIT



SOLDER PASTE EXAMPLE
BASED ON .005 INCH [0.125 MM] THICK STENCIL
SCALE:8X

4214825/C 02/2019

NOTES: (continued)

8. Laser cutting apertures with trapezoidal walls and rounded corners may offer better paste release. IPC-7525 may have alternate design recommendations.
9. Board assembly site may have different recommendations for stencil design.

IMPORTANT NOTICE AND DISCLAIMER

TI PROVIDES TECHNICAL AND RELIABILITY DATA (INCLUDING DATASHEETS), DESIGN RESOURCES (INCLUDING REFERENCE DESIGNS), APPLICATION OR OTHER DESIGN ADVICE, WEB TOOLS, SAFETY INFORMATION, AND OTHER RESOURCES "AS IS" AND WITH ALL FAULTS, AND DISCLAIMS ALL WARRANTIES, EXPRESS AND IMPLIED, INCLUDING WITHOUT LIMITATION ANY IMPLIED WARRANTIES OF MERCHANTABILITY, FITNESS FOR A PARTICULAR PURPOSE OR NON-INFRINGEMENT OF THIRD PARTY INTELLECTUAL PROPERTY RIGHTS.

These resources are intended for skilled developers designing with TI products. You are solely responsible for (1) selecting the appropriate TI products for your application, (2) designing, validating and testing your application, and (3) ensuring your application meets applicable standards, and any other safety, security, or other requirements. These resources are subject to change without notice. TI grants you permission to use these resources only for development of an application that uses the TI products described in the resource. Other reproduction and display of these resources is prohibited. No license is granted to any other TI intellectual property right or to any third party intellectual property right. TI disclaims responsibility for, and you will fully indemnify TI and its representatives against, any claims, damages, costs, losses, and liabilities arising out of your use of these resources.

TI's products are provided subject to TI's Terms of Sale (www.ti.com/legal/termsofsale.html) or other applicable terms available either on ti.com or provided in conjunction with such TI products. TI's provision of these resources does not expand or otherwise alter TI's applicable warranties or warranty disclaimers for TI products.

Mailing Address: Texas Instruments, Post Office Box 655303, Dallas, Texas 75265
Copyright © 2019, Texas Instruments Incorporated

Looking for pricing, stock, or lifecycle information?

Click below to explore more details on WIN SOURCE:

 [View OPA2889IDGSTG4 on WIN SOURCE](#)

 [Texas Instruments](#) Information

Optimize Your Supply Chain with WIN SOURCE Solutions

-  Global Sourcing Solution
-  Obsolete Management
-  Cost Control Management
-  Shortage Management
-  Alternative Solution
-  Excess Inventory Management