

# OV5658 5-megapixel product brief



## Full Resolution 5-Megapixel HD Video with High Dynamic Range for High-End Security and Surveillance Systems



available in  
a lead-free  
package

The OV5658 is a 5-megapixel CameraChip™ sensor designed specifically for high-end security and surveillance applications. The high performance OV5658 leverages a 1.75-micron OmniBSI+™ pixel to deliver industry-leading sensitivity and high dynamic range (HDR) while maintaining the standard form factor for security applications.

The sensor's industry-leading image and video quality ensure crisp and clear scene reproduction, even when recording in difficult lighting conditions. Additionally, the OV5658's resolution (up to 2592 x 1944 pixels) enables

advanced features such as video analytics, biometrics and facial recognition.

The OV5658 is the world's first security targeted, 1/3.2-inch sensor capable of capturing full-resolution 5-megapixel video at 30 frames per second (fps). The sensor is also capable of recording both 1080p or 720p HD video at 60 fps, or at 30 fps with extra pixels for electronic image stabilization (EIS).

Find out more at [www.ovt.com](http://www.ovt.com).



## Applications

- Security and Surveillance
- Digital Video Camcorders (DVC)
- Digital Still Cameras (DSC)
- PC Multimedia
- 3D Cameras

## Product Features

- 1.75  $\mu\text{m}$  x 1.75  $\mu\text{m}$  pixel with OmniBSI+™ technology for high performance (high sensitivity, low crosstalk, low noise)
- support for image sizes:
  - SMP (2592x1944)
  - EIS 1080p (2112x1188)
  - 1080p (1920x1080)
  - EIS 720p (1536x864)
  - 720p (1280x720)
  - VGA (640x480)
- programmable controls for:
  - frame rate
  - mirror and flip
  - cropping
  - windowing
  - scaling
- image quality controls:
  - defect pixel correction
  - lens shading correction
  - black level calibration
- support for output formats:
  - 10-bit RAW RGB
- supports horizontal and vertical subsampling
- fast mode switching
- supports 2x2 binning, re-sampling filter
- supports 3D applications
- EIS 1080p scalar (allows scale down to EIS 1080p or any size below)
- standard serial SCCB interface
- up to 4-lane MIPI/LVDS serial output interface
- embedded 64 bytes of one-time programmable (OTP) memory for part identification, etc.
- two on-chip phase lock loop (PLL)
- programmable I/O drive capability
- built-in 1.5V regulator for core
- supports alternate row HDR timing

# OV5658

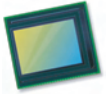

## Ordering Information

- OV05658-G04A (color, chip probing, 200  $\mu\text{m}$  backgrinding, reconstructed wafer with good die)
- OV05658-A66A (color, lead-free, 66-pin CSP)

## Product Specifications

- active array size: 2592 x 1944
- power supply:
  - core: 1.5V
  - analog: 2.6 - 3.0V
  - I/O: 1.7 - 3.0V
- power requirements:
  - active: 150 mA (325 mW)
  - standby: 300  $\mu\text{A}$
  - XSHUTDOWN: 2  $\mu\text{A}$
- temperature range:
  - operating: -30°C to +70°C junction temperature
  - stable image: 0°C to +50°C junction temperature
- output interfaces:
  - 4-lane MIPI/LVDS serial
- output formats: RAW RGB data
- lens size: 1/3.2"
- lens chief ray angle: 11° non-linear
- input clock frequency: 6 - 27 MHz
- scan mode: progressive
- maximum image transfer rate:
  - SMP (2592x1944): 30 fps
  - EIS 1080p (2112x1188): 30 fps
  - 1080p (1920x1080): 30 fps
  - EIS 720p (1536x864): 30 fps
  - 720p (1280x720): 60 fps
  - VGA (640x480): 90 fps
- sensitivity: 1200 mV/lux-sec
- max S/N ratio: 37 dB
- dynamic range: 73.7 dB @ 8x gain
- pixel size: 1.75  $\mu\text{m}$  x 1.75  $\mu\text{m}$
- image area: 4592  $\mu\text{m}$  x 3423  $\mu\text{m}$
- package/die dimensions:
  - CSP: 6360  $\mu\text{m}$  x 5670  $\mu\text{m}$
  - COB: 6350  $\mu\text{m}$  x 5660  $\mu\text{m}$

## Functional Block Diagram

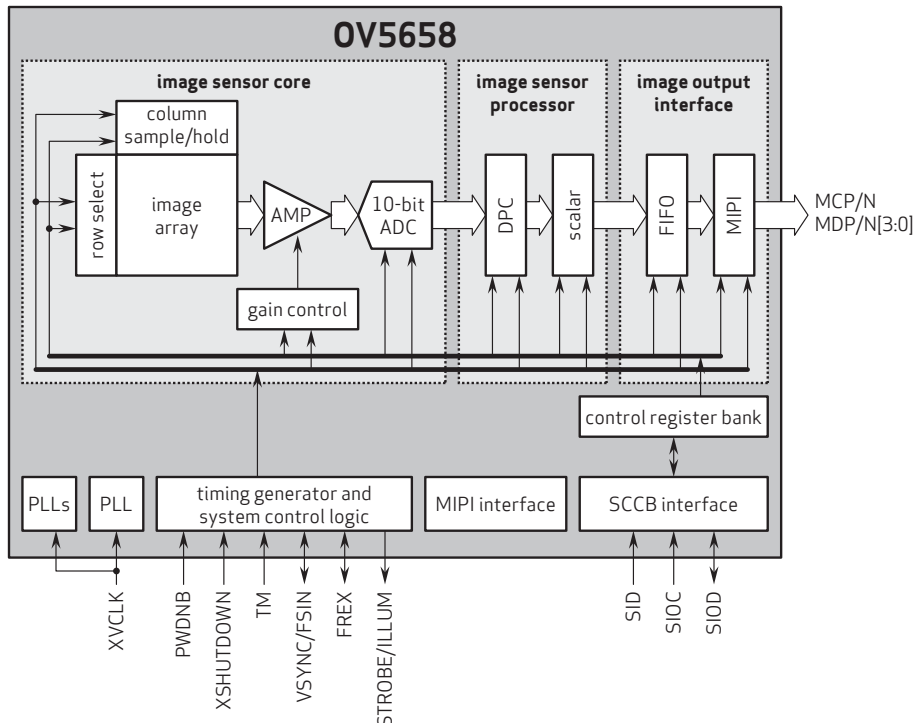

4275 Burton Drive  
Santa Clara, CA 95054  
USA

Tel: + 1 408 567 3000  
Fax: + 1 408 567 3001  
www.ovt.com

OmniVision reserves the right to make changes to their products or to discontinue any product or service without further notice. OmniVision and the OmniVision logo are registered trademarks of OmniVision Technologies, Inc. CameraChip and OmniBSI+ are trademarks of OmniVision Technologies, Inc. All other trademarks are the property of their respective owners.



OmniVision

## Looking for pricing, stock, or lifecycle information?

Click below to explore more details on WIN SOURCE:

- ⊖ [View OV05658-A66A on WIN SOURCE](#)
- ⊖ [OmniVision Technologies Inc Information](#)

## Optimize Your Supply Chain with WIN SOURCE Solutions

- ✓ Global Sourcing Solution
- ✓ Obsolete Management
- ✓ Cost Control Management
- ✓ Shortage Management
- ✓ Alternative Solution
- ✓ Excess Inventory Management