



**THE DATASHEET OF
SP-3205**





soberton inc.

SP DYNAMIC SPEAKER UNIT

Acoustic Product Specification

Product Number: SP-3205



Release | Revision: B/2017

CONTENTS

This document contains the technical specifications for the dynamic speaker unit.

Page 1

Speaker Electroacoustic Characteristics

General Specifications

Page 2

Reliability Tests

Page 3

Measuring Method (Speaker Mode)

Standard Test Condition of Speakers

Page 4

Frequency Response Curve

Page 5

Dimensions

Page 6

Packing

Dynamic Speaker Electroacoustic Characteristics

Sound Pressure Level

92±3dB SPL @0.5, 0.8, 1.0 and 2.0KHz in average (0dB SPL=20μPa)
Measuring Condition: 0.1W (Sine wave) 10cm measured with baffler shown in Fig.1

AC Impedance

8±15%Ω (@ 2 KHz 1V) without baffler

Frequency Response Curve

As shown in Figure 2

Response Frequency

550 ± 20%Hz @ 1V. (Without Baffler)

Input Power (Nominal and Maximum)

Rated Noise Power: 0.8W

Short Term Max Power: 1.2W must be normal at a white noise (1W, F0 ~ 20KHz) for one minute

Operation Test

Must be free audible noise (buzzes and rattles)

300 ~ 8KHz frequency range, input level up to 2.53Vrms

Distortion

Less than 10% @1KHz , 0.1M , 0.8W frequency range, input level up to 0.8W

General Specifications

Operating Temperature Range

-20°C~+55°C

Standard Test Conditions

Temperature 17°C~25°C

Relative Humidity 45%~80%(RH)

Dimension

Ø32 x 5.2mm

IP Level

No rating



soberton inc.

SP DYNAMIC SPEAKER UNIT

Acoustic Product Specification

Product Number: SP-3205



Release | Revision: B/2017

CONTENTS

This document contains the technical specifications for the dynamic speaker unit.

Page 1

Speaker Electroacoustic Characteristics

General Specifications

Page 2

Reliability Tests

Page 3

Measuring Method (Speaker Mode)

Standard Test Condition of Speakers

Page 4

Frequency Response Curve

Page 5

Dimensions

Page 6

Packing

Reliability Tests

The sound pressure as specified will neither deviate more than $\pm 3\text{dB}$ from the initial value, nor have any significant damage after any of following testing.

High Temperature Test

High Temperature $+60\pm 2^\circ\text{C}$

Duration 96 hours

Low Temperature Test

Low Temperature $-20\pm 2^\circ\text{C}$

Duration 96 hours

Heat Shock Test

High Temperature $+60\pm 2^\circ\text{C}$

Low Temperature $-20\pm 2^\circ\text{C}$

Changeover Time < 30 seconds

Duration 1 hour

Cycle 100

Humidity Test

Temperature $+40\pm 2^\circ\text{C}$

Relative Humidity 90%~95%

Duration 96 hours

Temperature Cycle Test

Temperature -20°C $+60^\circ\text{C}$

Duration 45 minutes 45 minutes

Temperature gradient $1\sim 3^\circ\text{C}/\text{min}$

Cycle 25

Drop Test

Mounted with dummy set mass 100 g

Height 1.5 m

Cycle 6 (1 each plain) onto the concrete board

Load Test

Speaker mode: White noise (EIA filter) for 96 hours @ 0.8W input power.



soberton inc.

SP DYNAMIC SPEAKER UNIT

Acoustic Product Specification

Product Number: SP-3205



Release | Revision: B/2017

CONTENTS

This document contains the technical specifications for the dynamic speaker unit.

Page 1
Speaker Electroacoustic Characteristics

General Specifications

Page 2
Reliability Tests

Page 3
Measuring Method (Speaker Mode)

Standard Test Condition of Speakers

Page 4
Frequency Response Curve

Page 5
Dimensions

Page 6
Packing

Measuring Method (Speaker Mode)

Standard Test Condition

Temperature 15 ~ 35°C

Relative humidity 45% ~ 85%

Atmospheric pressure 860mbar to 1060mbar

Standard Test Fixture

Input Power 0.1W (0.89V)

Zero Level -dB

Mode TSR

Potentiometer Range 50dB

Sweep Time 0.5sec

Standard Test Condition of Speaker (Fig, 1)

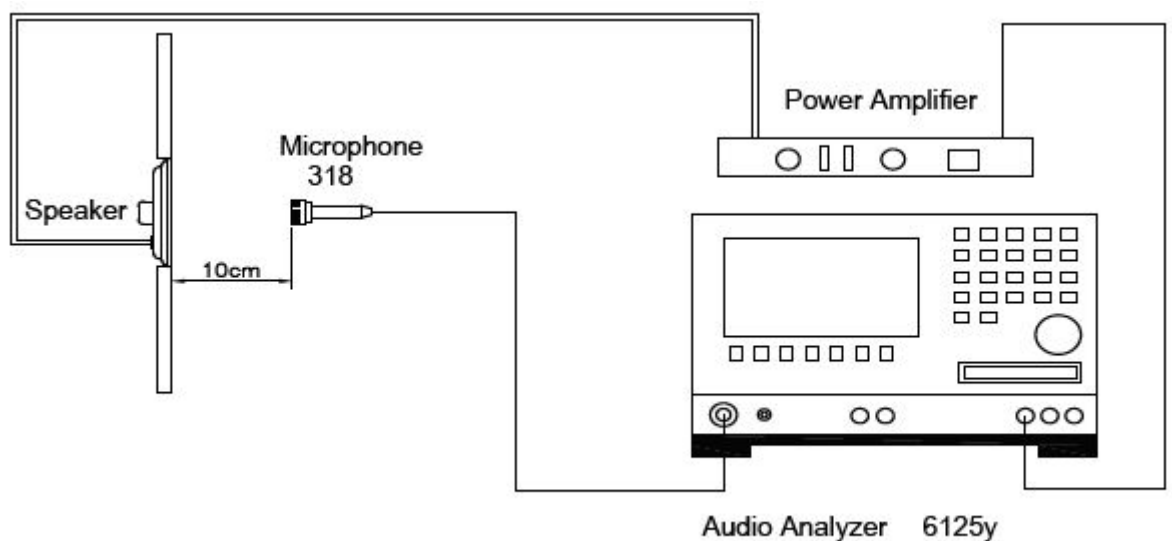



soberton inc.

SP DYNAMIC SPEAKER UNIT

Acoustic Product Specification

Product Number: SP-3205



Release | Revision: B/2017

CONTENTS

This document contains the technical specifications for the dynamic speaker unit.

Page 1
Speaker Electroacoustic Characteristics

General Specifications

Page 2
Reliability Tests

Page 3
Measuring Method (Speaker Mode)

Standard Test Condition of Speakers

Page 4
Frequency Response Curve

Page 5
Dimensions

Page 6
Packing

Frequency Response Curve (Fig. 2)

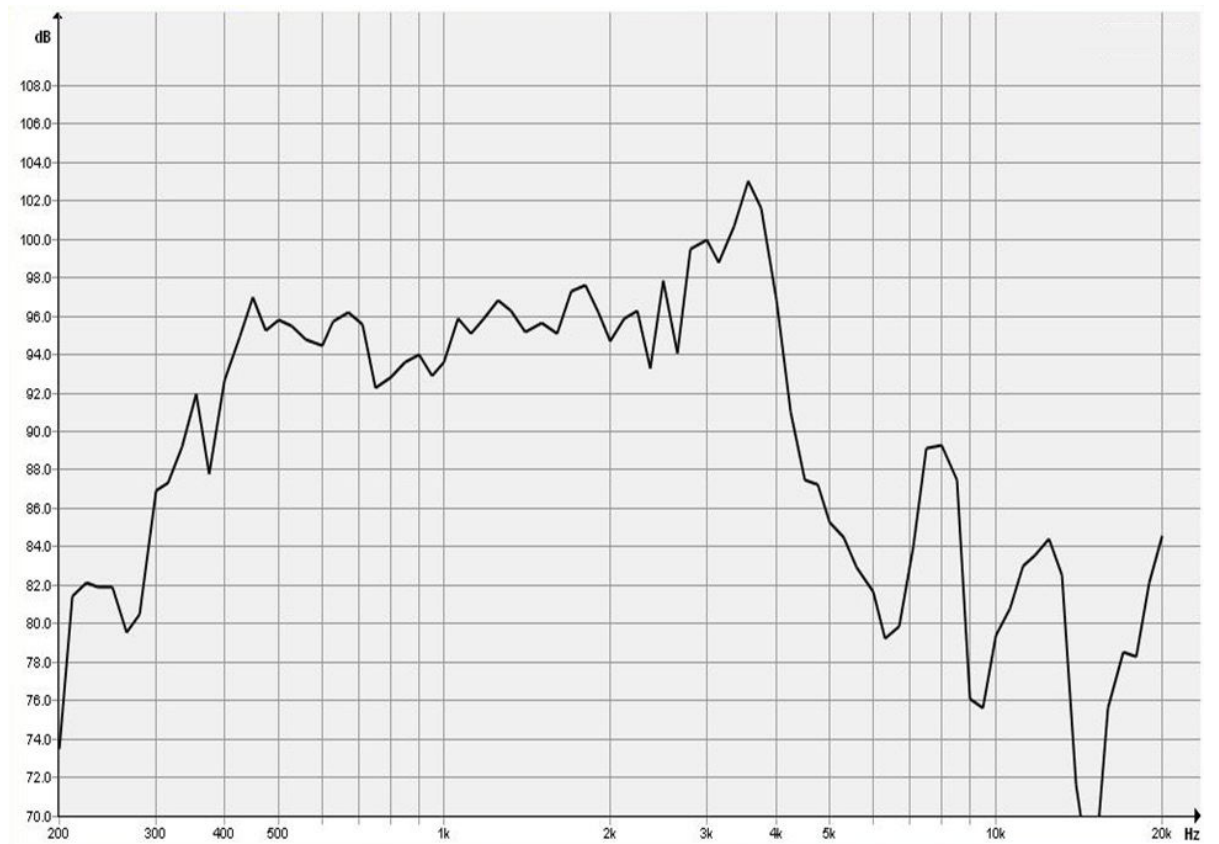



soberton inc.

SP DYNAMIC SPEAKER UNIT

Acoustic Product Specification

Product Number: SP-3205



Release | Revision: B/2017

CONTENTS

This document contains the technical specifications for the dynamic speaker unit.

Page 1

Speaker Electroacoustic Characteristics

General Specifications

Page 2

Reliability Tests

Page 3

Measuring Method (Speaker Mode)

Standard Test Condition of Speakers

Page 4

Frequency Response Curve

Page 5

Dimensions

Page 6

Packing

Dimensions

Tolerance: ± 0.5 (unit: mm)

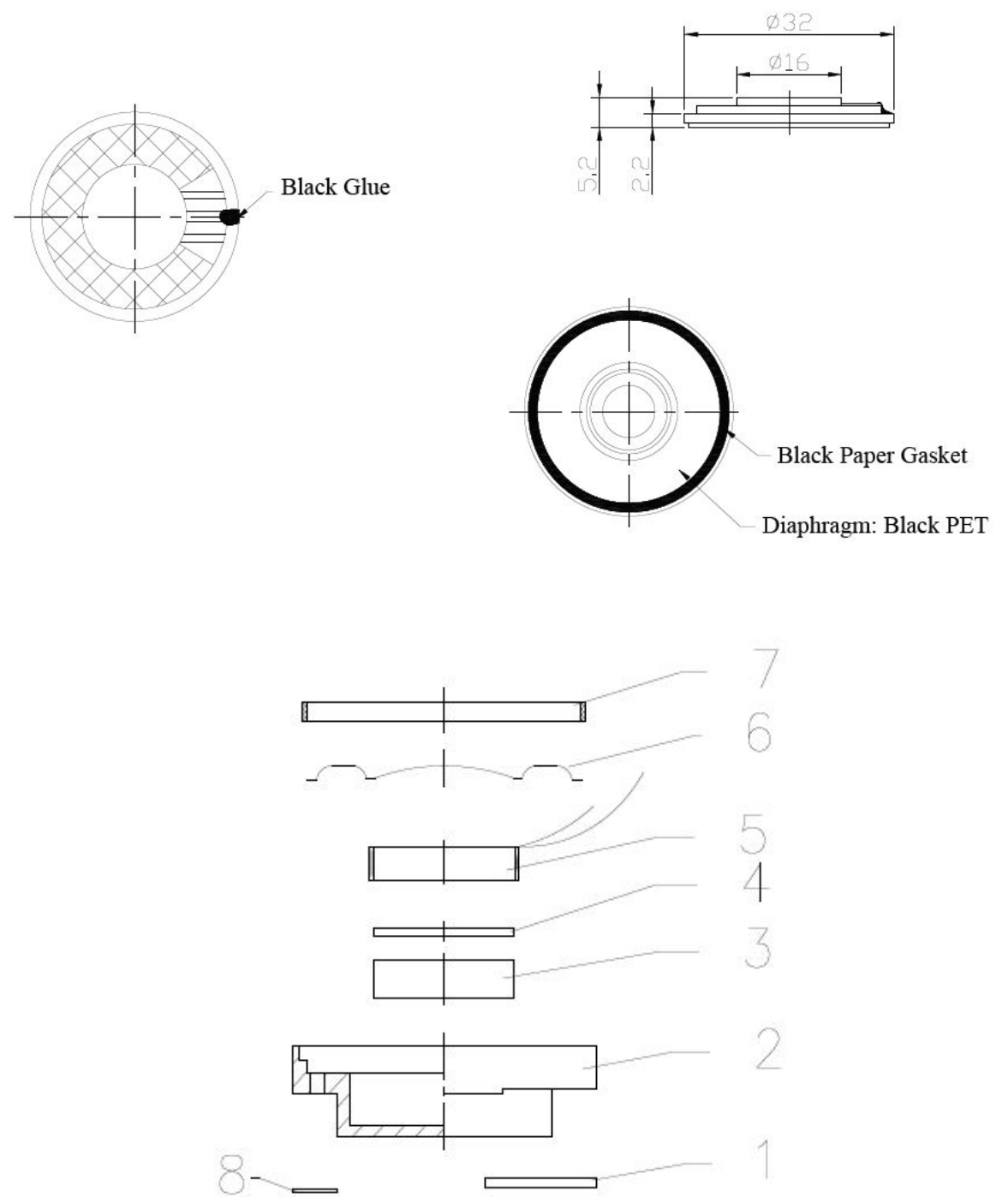

No.	Part Name	Material	Quantity
1	PCB	FR-4	1
2	Frame	SPCC	1
3	Magnet	$\phi 12.5 \times 1.5$ -N38	1
4	Plate	$\phi 12.7 \times 0.8$ SPCC	1
5	Voice Coil	13.3-2.0-7.4	1
6	Diaphragm	PET	1
7	Gasket	Black paper	1
8	Silk Screen	Black cloth	1



soberton inc.

SP DYNAMIC SPEAKER UNIT

Acoustic Product Specification

Product Number: SP-3205



Release | Revision: B/2017

CONTENTS

This document contains the technical specifications for the dynamic speaker unit.

Page 1

Speaker Electroacoustic Characteristics

General Specifications

Page 2

Reliability Tests

Page 3

Measuring Method (Speaker Mode)

Standard Test Condition of Speakers

Page 4

Frequency Response Curve

Page 5

Dimensions

Page 6

Packing

Packing

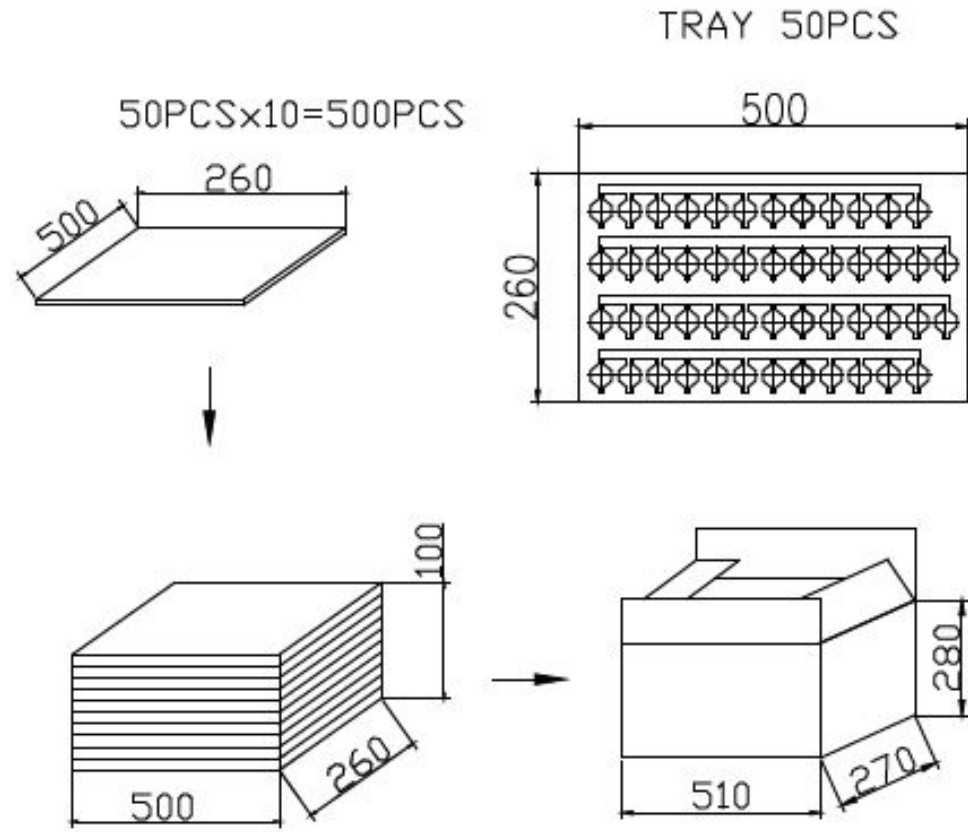

TRAY	500X260X10mm	1X50PCS=50PCS
CARTON BOX	510X270X280mm	20X50PCS=1000PCS

Looking for pricing, stock, or lifecycle information?

Click below to explore more details on WIN SOURCE:

[View SP-3205 on WIN SOURCE](#)

[Soberton Inc. Information](#)

Optimize Your Supply Chain with WIN SOURCE Solutions

- ✓ Global Sourcing Solution
- ✓ Obsolete Management
- ✓ Cost Control Management
- ✓ Shortage Management
- ✓ Alternative Solution
- ✓ Excess Inventory Management