



PCA9691

8-bit A/D and D/A converter

Rev. 02 — 27 January 2010

Product data sheet

1. General description

The PCA9691 is a single chip, single supply, low power, 8-bit CMOS¹ data acquisition device with four analog inputs, one analog output and a serial I²C-bus interface. Three address pins (A0, A1, and A2) are used for programming the hardware address, allowing the use of up to 64 PCA9691 devices connected to the I²C-bus without additional hardware. Address, control and data to and from the PCA9691 are transferred via the serial two-line bidirectional I²C-bus.

The functions of the PCA9691 include:

- Analog input multiplexing
- On-chip sample and hold
- 8-bit Analog-to-Digital (A/D) conversion
- 8-bit Digital-to-Analog (D/A) conversion

The maximum conversion rate is given by the maximum frequency of the I²C-bus.

2. Features

- 8-bit successive approximation A/D conversion
- Four analog inputs programmable as single-ended or differential inputs
- 64 different addresses by three hardware address pins
- 1 MHz Fast-mode Plus (Fm+) I²C-bus via serial input/output
- Sampling rate given by I²C-bus frequency
- Single supply voltage; operating from 2.5 V to 5.5 V
- Low standby current
- Analog voltage from V_{SS} to V_{DD}
- Multiplying Digital-to-Analog Converter (DAC) with one analog output
- On-chip sample and hold circuit
- Auto-incremented channel selection

1. The definition of the abbreviations and acronyms used in this data sheet can be found in [Section 14](#).

3. Ordering information

Table 1. Ordering information

Type number	Package		Version
	Name	Description	
PCA9691BS	HVQFN16	plastic thermal enhanced very thin quad flat package; no leads; 16 terminals; body 4 × 4 × 0.85 mm	SOT629-1
PCA9691TS	TSSOP16	plastic thin shrink small outline package; 16 leads; body width 4.4 mm	SOT403-1
PCA9691T	SO16	plastic small outline package; 16 leads; body width 7.5 mm	SOT162-1

4. Marking

Table 2. Marking codes

Type number	Marking code
PCA9691BS	9691
PCA9691TS	PCA9691
PCA9691T	PCA9691T

5. Block diagram

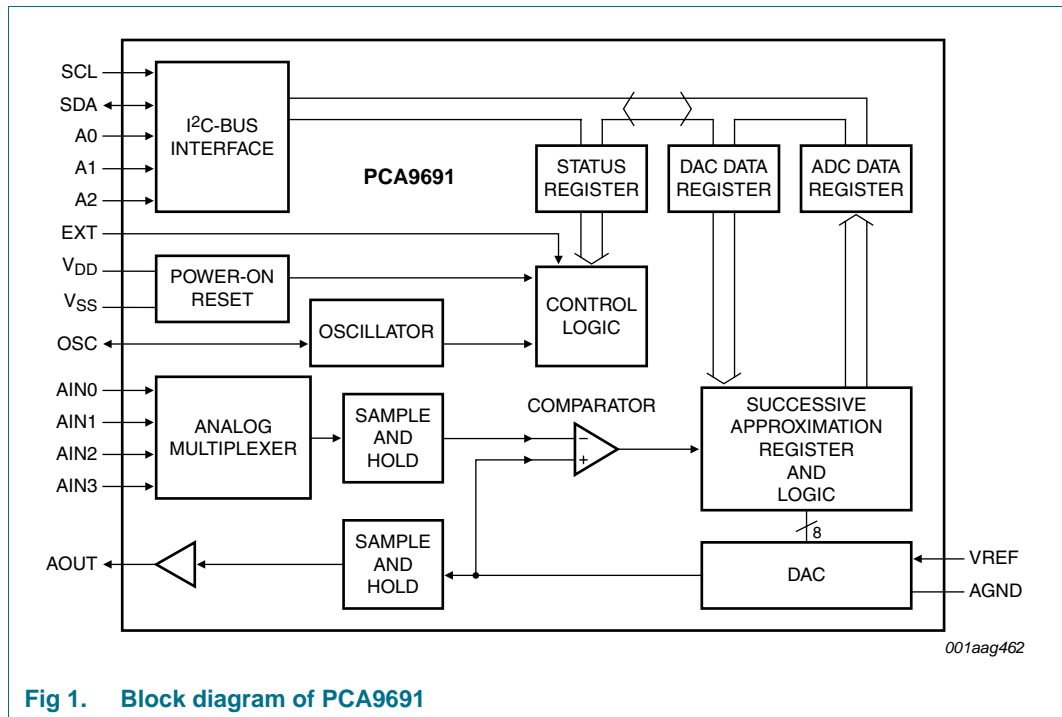
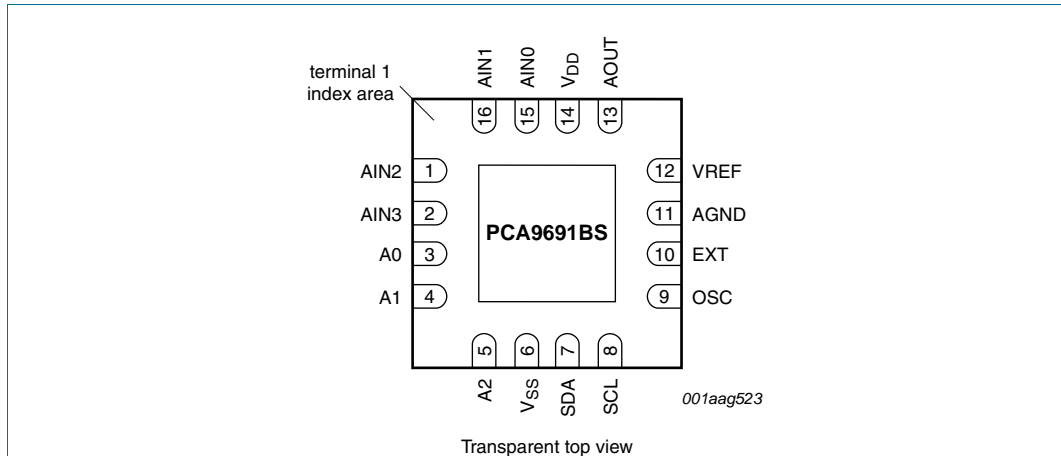

Fig 1. Block diagram of PCA9691

6. Pinning information

6.1 Pinning



For mechanical details, see [Figure 25](#).

Fig 2. Pin configuration for HVQFN16 (PCA9691BS)

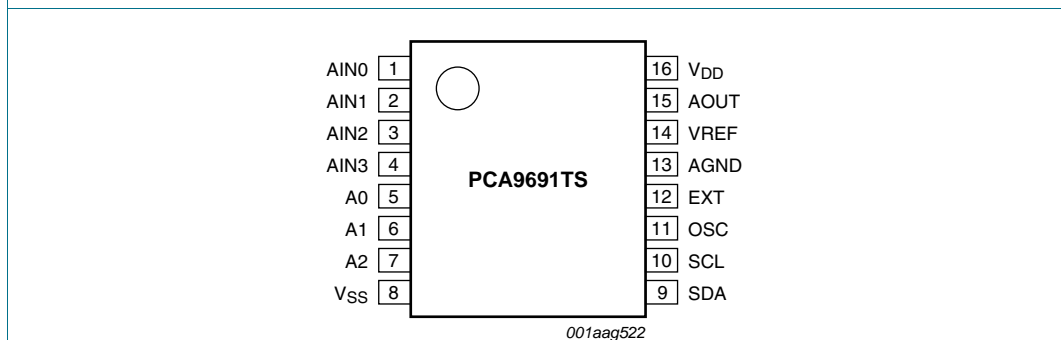

Top view. For mechanical details, see [Figure 26](#).

Fig 3. Pin configuration for TSSOP16 (PCA9691TS)

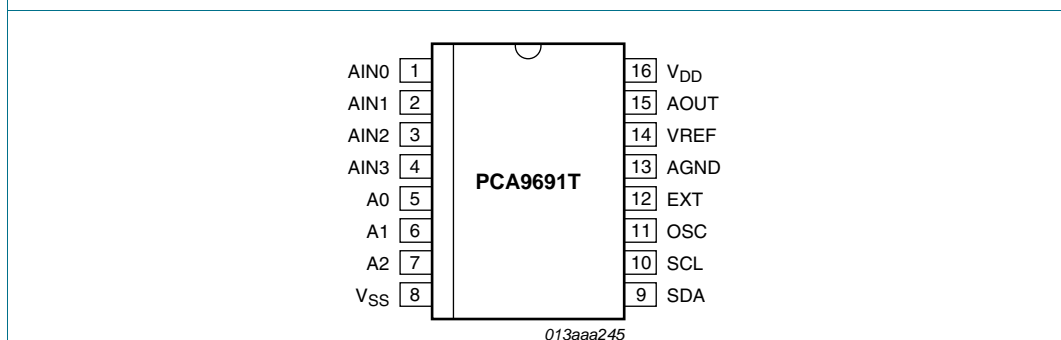

Top view. For mechanical details, see [Figure 27](#).

Fig 4. Pin configuration for SO16 (PCA9691T)

6.2 Pin description

Table 3. Pin description

Symbol	Pin			Type	Description
	HVQFN16 (PCA9691BS)	TSSOP16 (PCA9691TS)	SO16 (PCA9691T)		
AIN0	15	1	1	input	analog input 0
AIN1	16	2	2	input	analog input 1
AIN2	1	3	3	input	analog input 2
AIN3	2	4	4	input	analog input 3
A0	3	5	5	input	address input 0
A1	4	6	6	input	address input 1
A2	5	7	7	input	address input 2
V _{SS}	6 ^[1]	8	8	ground	ground supply (analog and digital)
SDA	7	9	9	input/output	I ² C-bus data input and output
SCL	8	10	10	input	I ² C-bus clock input
OSC	9	11	11	input/output	oscillator signal selection: input, if pin EXT is HIGH output, if pin EXT is LOW
EXT	10	12	12	input	oscillator selection input: HIGH: external oscillator LOW: internal oscillator
AGND	11	13	13	ground	DAC analog ground
VREF	12	14	14	input	DAC reference voltage input
AOUT	13	15	15	output	analog output
V _{DD}	14	16	16	supply	supply voltage

[1] The die paddle (exposed pad) is connected to V_{SS} and should be electrically isolated.

7. Functional description

7.1 Addressing

Each PCA9691 device in an I²C-bus system is activated by sending a valid address to the device. The address consists of seven programmable bits and one read/write bit. The address must be set according to Table 4. The three input pins (A2, A1, and A0) are used to encode the seven address bits (A[6:0]), where each of the pins can be connected to V_{DD}, V_{SS}, SCL, or SDA. The address is always sent as the first byte after the start condition in the I²C-bus protocol. The last bit of the address byte is the read/write bit which sets the direction of the following data transfer (see Figure 5, Figure 18, and Figure 19).

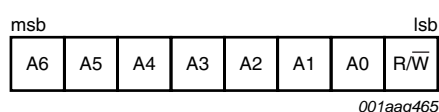

Fig 5. Address byte

7.1.1 Address map

Table 4. PCA9691 address map

Pin			Bit								Address	Number
A2	A1	A0	A6	A5	A4	A3	A2	A1	A0	R/W		
V _{SS}	V _{SS}	SDA	0	1	0	0	0	0	0	0	40h	1
V _{SS}	V _{DD}	SDA	0	1	0	0	0	0	1	0	42h	2
V _{DD}	V _{SS}	SDA	0	1	0	0	0	1	0	0	44h	3
V _{DD}	V _{DD}	SDA	0	1	0	0	0	1	1	0	46h	4
V _{SS}	SDA	V _{SS}	0	1	0	0	1	0	0	0	48h	5
V _{SS}	SDA	V _{DD}	0	1	0	0	1	0	1	0	4Ah	6
V _{DD}	SDA	V _{SS}	0	1	0	0	1	1	0	0	4Ch	7
V _{DD}	SDA	V _{DD}	0	1	0	0	1	1	1	0	4Eh	8
SDA	V _{SS}	V _{SS}	0	1	0	1	0	0	0	0	50h	9
SDA	V _{SS}	V _{DD}	0	1	0	1	0	0	1	0	52h	10
SDA	V _{DD}	V _{SS}	0	1	0	1	0	1	0	0	54h	11
SDA	V _{DD}	V _{DD}	0	1	0	1	0	1	1	0	56h	12
V _{SS}	SDA	SDA	0	1	0	1	1	0	0	0	58h	13
V _{DD}	SDA	SDA	0	1	0	1	1	0	1	0	5Ah	14
SDA	V _{SS}	SDA	0	1	0	1	1	1	0	0	5Ch	15
SDA	V _{DD}	SDA	0	1	0	1	1	1	1	0	5Eh	16
SDA	SDA	V _{SS}	0	1	1	0	0	0	0	0	60h	17
SDA	SDA	V _{DD}	0	1	1	0	0	0	1	0	62h	18
SDA	SDA	SDA	0	1	1	0	0	1	0	0	64h	19
SCL	SCL	SCL	0	1	1	0	0	1	1	0	66h	20
V _{SS}	V _{SS}	SCL	0	1	1	0	1	0	0	0	68h	21
V _{SS}	V _{DD}	SCL	0	1	1	0	1	0	1	0	6Ah	22
V _{DD}	V _{SS}	SCL	0	1	1	0	1	1	0	0	6Ch	23
V _{DD}	V _{DD}	SCL	0	1	1	0	1	1	1	0	6Eh	24
V _{SS}	SCL	V _{SS}	0	1	1	1	0	0	0	0	70h	25
V _{SS}	SCL	V _{DD}	0	1	1	1	0	0	1	0	72h	26
V _{DD}	SCL	V _{SS}	0	1	1	1	0	1	0	0	74h	27
V _{DD}	SCL	V _{DD}	0	1	1	1	0	1	1	0	76h	28
SCL	V _{SS}	V _{SS}	0	1	1	1	1	0	0	0	78h	29
SCL	V _{SS}	V _{DD}	0	1	1	1	1	0	1	0	7Ah	30
SCL	V _{DD}	V _{SS}	0	1	1	1	1	1	0	0	7Ch	31
SCL	V _{DD}	V _{DD}	0	1	1	1	1	1	1	0	7Eh	32
V _{SS}	SCL	SCL	1	0	0	0	0	0	0	0	80h	33
V _{DD}	SCL	SCL	1	0	0	0	0	0	1	0	82h	34
SCL	V _{SS}	SCL	1	0	0	0	0	1	0	0	84h	35
SCL	V _{DD}	SCL	1	0	0	0	0	1	1	0	86h	36
SCL	SCL	V _{SS}	1	0	0	0	1	0	0	0	88h	37
SCL	SCL	V _{DD}	1	0	0	0	1	0	1	0	8Ah	38

Table 4. PCA9691 address map ...continued

Pin			Bit								Address	Number
A2	A1	A0	A6	A5	A4	A3	A2	A1	A0	R/W		
V _{SS}	SCL	SDA	1	0	0	0	1	1	0	0	8Ch	39
V _{DD}	SCL	SDA	1	0	0	0	1	1	1	0	8Eh	40
V _{SS}	V _{SS}	V _{SS}	1	0	0	1	0	0	0	0	90h	41
V _{SS}	V _{SS}	V _{DD}	1	0	0	1	0	0	1	0	92h	42
V _{SS}	V _{DD}	V _{SS}	1	0	0	1	0	1	0	0	94h	43
V _{SS}	V _{DD}	V _{DD}	1	0	0	1	0	1	1	0	96h	44
V _{DD}	V _{SS}	V _{SS}	1	0	0	1	1	0	0	0	98h	45
V _{DD}	V _{SS}	V _{DD}	1	0	0	1	1	0	1	0	9Ah	46
V _{DD}	V _{DD}	V _{SS}	1	0	0	1	1	1	0	0	9Ch	47
V _{DD}	V _{DD}	V _{DD}	1	0	0	1	1	1	1	0	9Eh	48
V _{SS}	SDA	SCL	1	0	1	0	0	0	0	0	A0h	49
V _{DD}	SDA	SCL	1	0	1	0	0	0	1	0	A2h	50
SCL	SDA	V _{SS}	1	0	1	0	0	1	0	0	A4h	51
SCL	SDA	V _{DD}	1	0	1	0	0	1	1	0	A6h	52
SDA	SCL	V _{SS}	1	0	1	0	1	0	0	0	A8h	53
SDA	SCL	V _{DD}	1	0	1	0	1	0	1	0	AAh	54
SDA	V _{SS}	SCL	1	0	1	0	1	1	0	0	ACh	55
SDA	V _{DD}	SCL	1	0	1	0	1	1	1	0	A Eh	56
SCL	V _{SS}	SDA	1	0	1	1	0	0	0	0	B0h	57
SCL	V _{DD}	SDA	1	0	1	1	0	0	1	0	B2h	58
SDA	SCL	SCL	1	0	1	1	0	1	0	0	B4h	59
SCL	SDA	SCL	1	0	1	1	0	1	1	0	B6h	60
SCL	SCL	SDA	1	0	1	1	1	0	0	0	B8h	61
SCL	SDA	SDA	1	0	1	1	1	0	1	0	BAh	62
SDA	SCL	SDA	1	0	1	1	1	1	0	0	BCh	63
SDA	SDA	SCL	1	0	1	1	1	1	1	0	BEh	64

7.2 Control byte

The second byte sent to a PCA9691 is stored in its control register and is required to control the PCA9691 function.

The upper nibble of the control register is used for enabling the analog output, and for programming the analog inputs as single-ended or differential inputs. The lower nibble selects one of the analog input channels defined by the upper nibble (see [Figure 6](#)).

If the auto-increment flag is set, the channel number is incremented automatically after each A/D conversion.

If the auto-increment mode is selected and the internal oscillator is used, the analog output enable flag in the control byte (bit 6) must be set. This allows the internal oscillator to run continuously, thereby preventing conversion errors resulting from oscillator start-up delay. The analog output enable flag can be reset at other times to reduce quiescent power consumption.

The selection of a non-existing input channel results in the highest available channel number being allocated. Therefore, if the auto-increment flag is set, the next selected channel is always channel 0.

After power-on all bits of the control register are reset to logic 0. The DAC and the oscillator are disabled for power saving. The analog output is switched to a high-impedance state.

The most significant bits of both nibbles are reserved for oscillator control. Bit 7 and bit 3 can be set when the interface frequency is $f_{SCL} \leq 400$ kHz (see [Figure 6](#)). Setting these two bits to logic 1 sets the internal frequency to half and the accuracy of the A/D and D/A conversion is 1 LSB as indicated in [Table 8](#) and [Table 9](#).

The oscillator output is disabled in normal operation (pin OSC is LOW). Setting bit 7 to logic 0 and bit 3 to logic 1 will enable this output in order to observe the oscillator frequency (divided by 4).

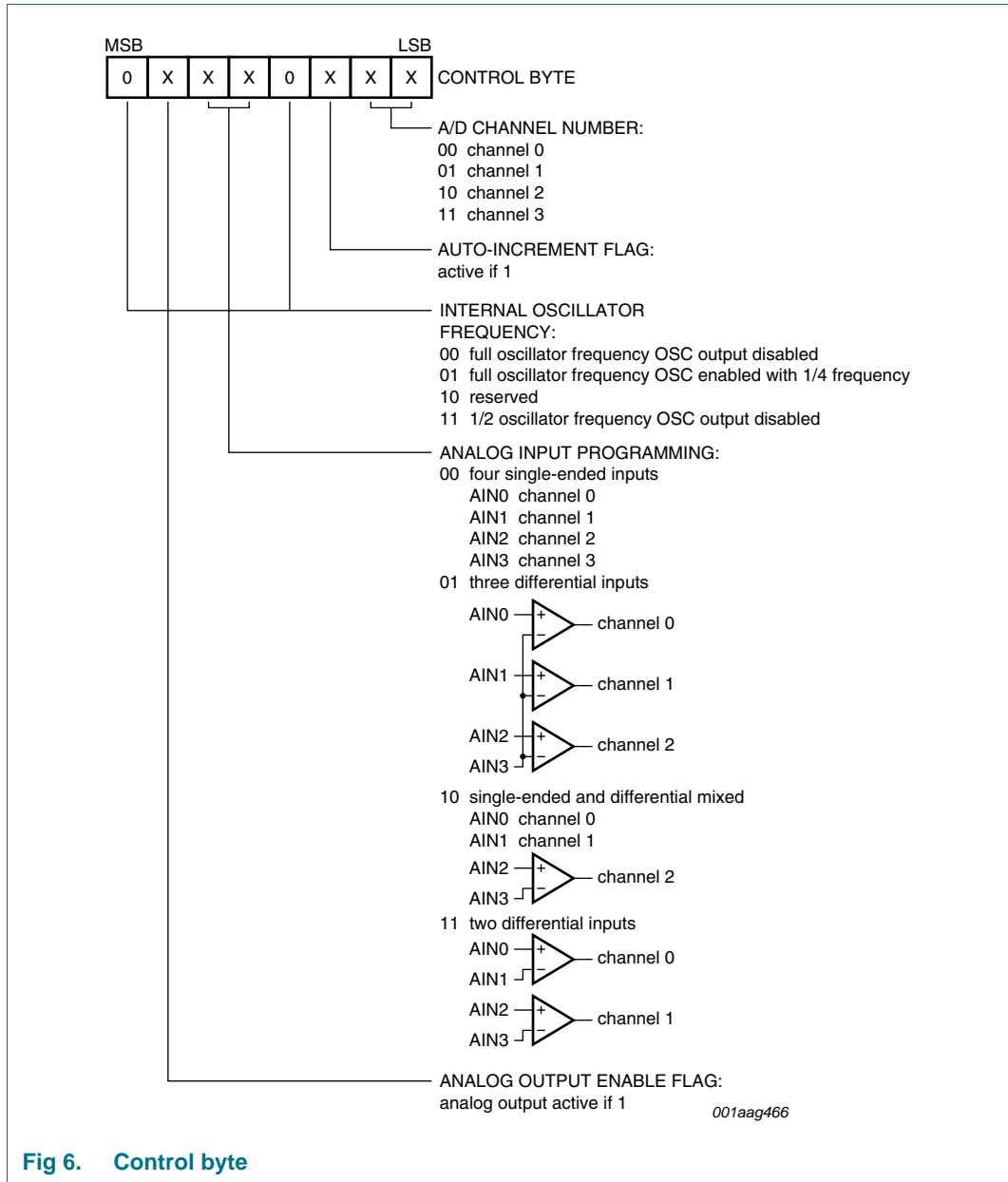

Fig 6. Control byte

7.3 D/A conversion

The third byte sent to a PCA9691 is stored in the DAC data register and is converted to the corresponding analog voltage using the on-chip DAC. This DAC consists of a resistor divider chain connected to the external reference voltage (pin VREF) with 256 taps and selection switches. The tap-decoder switches one of these taps to the DAC output line (see [Figure 7](#)).

The analog output voltage is buffered by an auto-zeroed unity gain amplifier. Setting the analog output enable flag of the control register switches this buffer amplifier on or off. In the active state the output voltage is held until a further data byte is sent.

In order to release the DAC for a successive approximation A/D conversion cycle, the unity gain amplifier is equipped with a sample and hold circuit. This circuit holds the output voltage while executing the A/D conversion.

The formula for the output voltage supplied to the analog output pin AOUT is shown in [Figure 8](#).

The waveforms of a D/A conversion sequence are shown in [Figure 9](#).

With the rising edge of the 8th clock bit the DAC register is filled with a new value D7 to D0. After some delay the voltage at the analog output starts to change from the previous value to the new value.

This delay is random but stays within the following limits:

- Minimum $8T_{osc}$ from the rising edge of the 8th bit
- Maximum $18T_{osc}$ from the rising edge of the acknowledge bit (9th bit)

Where T_{osc} is the oscillator period (oscillator frequency is given in [Table 6](#)).

Remark: When AOUT starts changing, the DAC settling time $t_{s(DAC)}$ (specified in [Table 8](#)), is required for AOUT to reach a new accurate value.

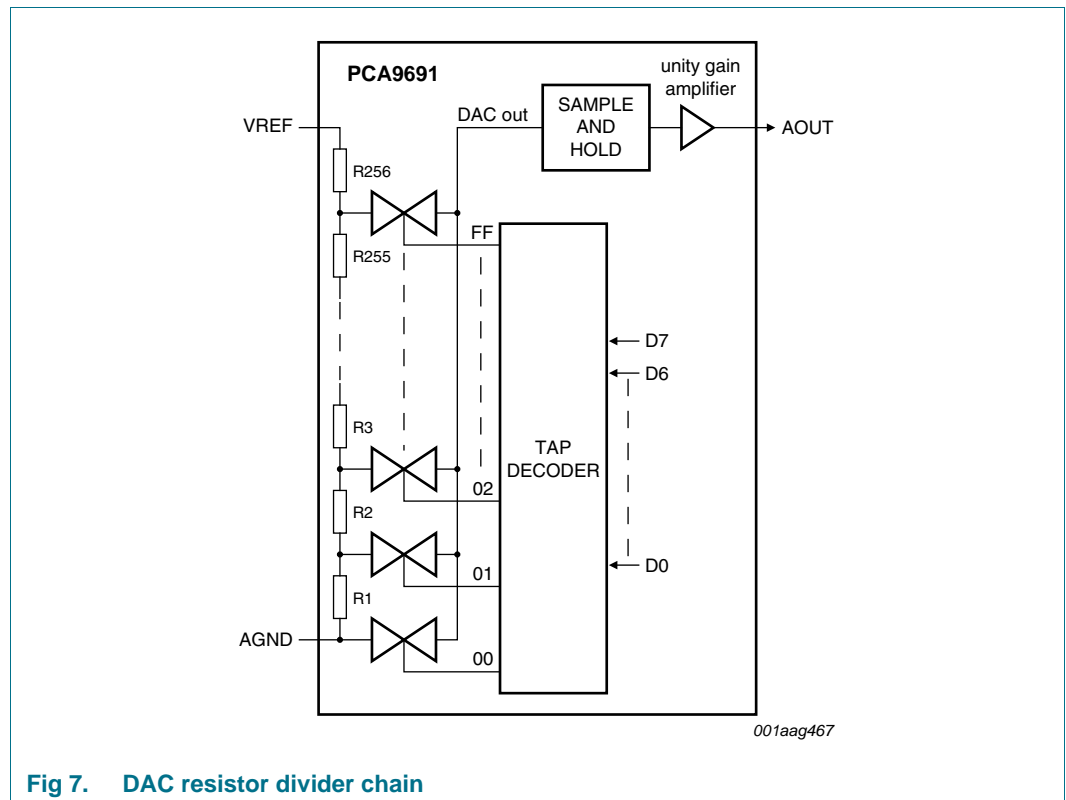

Fig 7. DAC resistor divider chain

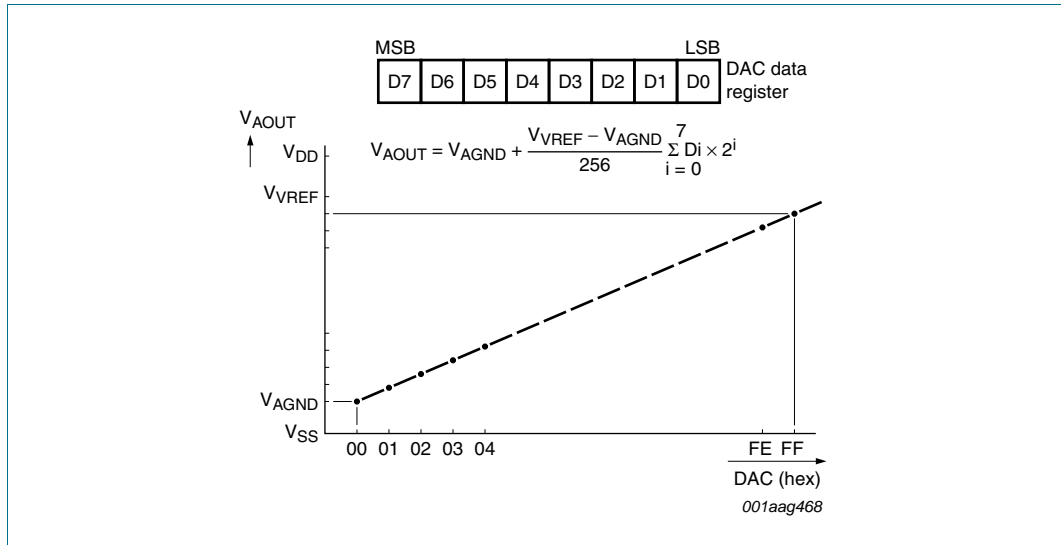

Fig 8. DAC data and DC conversion characteristics

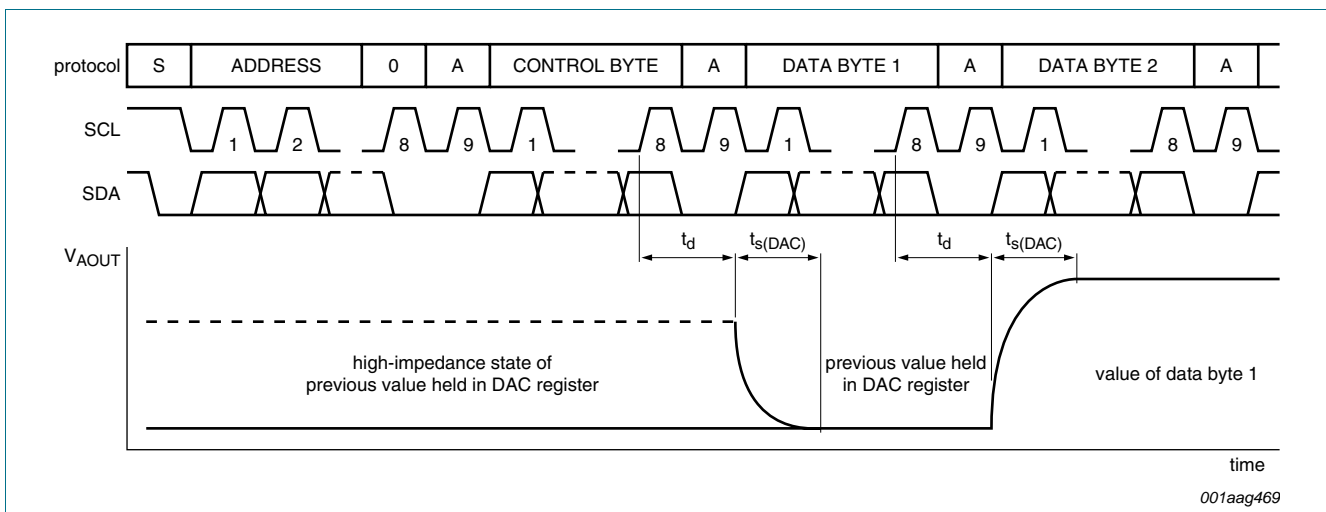

Fig 9. D/A conversion sequence

7.3.1 Worst case example

An example of the worst case is shown in [Figure 10](#). The delay time can have a value between $8T_{osc}$ and $18T_{osc}$.

When the I²C-bus is driven at 1 MHz (full speed) then the DAC is operating at a rate of 9 μs.

The previous AOUT value is valid at least until the rising edge of the acknowledge bit ($8T_{osc} \geq 1.23 \mu s$).

The latest start time of the new value is 5.6 μs from the rising edge of the acknowledge bit: ($18T_{osc} \leq 5.6 \mu s$) so AOUT is stable after $t_{s(DAC)} \leq 2.4 \mu s$.

The new AOOUT value is valid, at the latest, after 8.0 μs so before the rising edge of the 8th bit of the next transferred byte. Therefore, at the full speed of the I²C-bus, the analog output is valid under all circumstances between the rising edges of the 8th bit and the acknowledge bit.

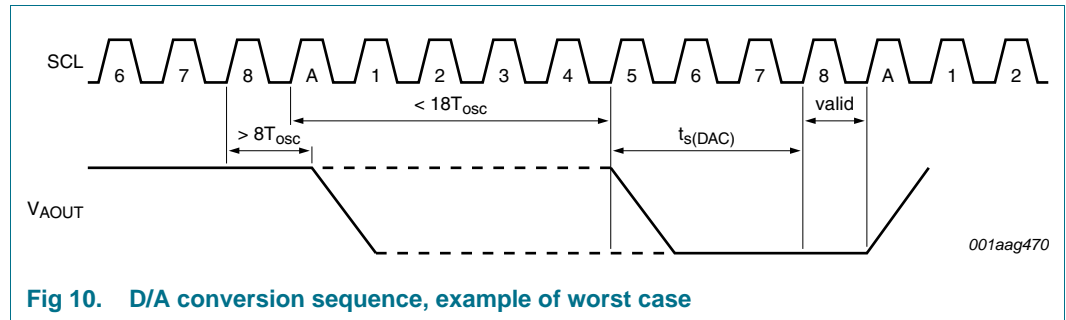

Fig 10. D/A conversion sequence, example of worst case

7.4 A/D conversion

The A/D Converter (ADC) makes use of the successive approximation conversion technique. The on-chip DAC and a high-gain comparator are used temporarily during an A/D conversion cycle.

An A/D conversion cycle is always started after sending a valid read mode address to a PCA9691. The A/D conversion cycle is triggered at the trailing edge of the acknowledge clock pulse and is executed while transmitting the result of the previous conversion (see [Figure 11](#)).

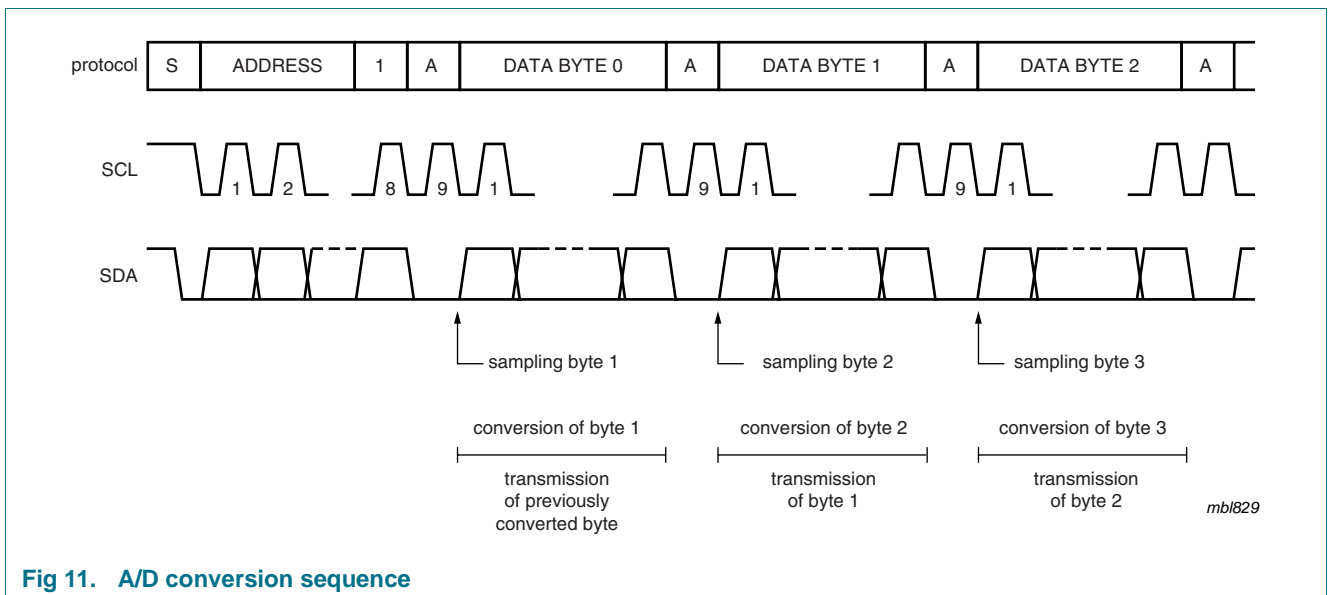

Fig 11. A/D conversion sequence

Once a conversion cycle is triggered, an input voltage sample of the selected channel is stored on the chip and is converted to the corresponding 8-bit binary code. Samples picked up from differential inputs are converted to an 8-bit two's complement code (see [Figure 12](#) and [Figure 13](#)).

The conversion result is stored in the ADC data register and awaits transmission. If the auto-increment flag is set the next channel is selected.

The first byte transmitted in a read cycle contains the conversion result code of the previous read cycle. After a Power-On Reset (POR) condition the first byte read is 80h. The protocol of an I²C-bus read cycle is shown in [Figure 19](#).

The actual speed of the I²C-bus provides the maximum A/D conversion rate.

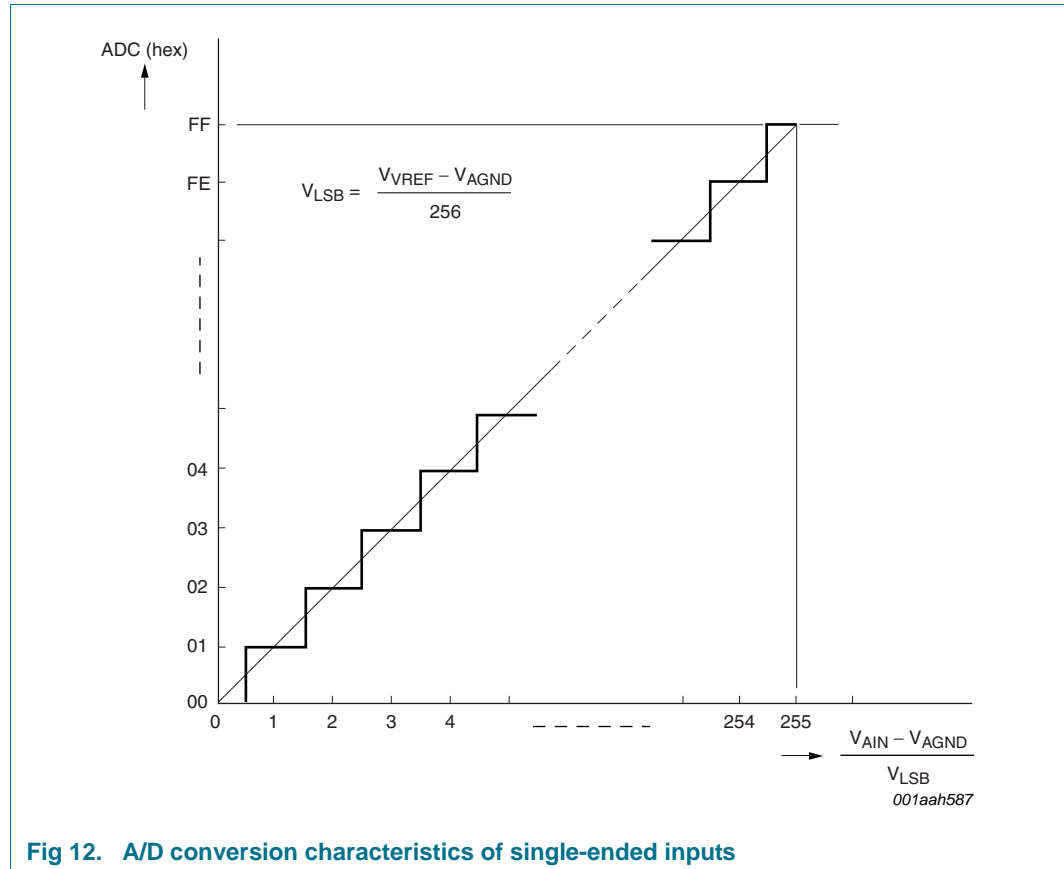

Fig 12. A/D conversion characteristics of single-ended inputs

It is recommended that if the I²C-bus speed $f_{SCL} \leq 400$ kHz, you must reduce the oscillator frequency by half (see the definition of the control byte in [Figure 6](#)).

If pin EXT is connected to V_{DD} the oscillator output OSC is switched to a high-impedance state allowing to feed an external clock signal to the OSC input. The frequency of the external clock must be in the specified range.

7.7 Characteristics of the I²C-bus

The I²C-bus is for bidirectional, two-line communication between different IC or modules. The two lines are a Serial DATA Line (SDA) and a Serial Clock Line (SCL). Both lines are connected to a positive supply via a pull-up resistor. Data transfer is initiated only when the bus is not busy.

7.7.1 Bit transfer

One data bit is transferred during each clock pulse. The data on the SDA line remains stable during the HIGH period of the clock pulse as changes in the data line at this time are interpreted as control signals (see [Figure 14](#)).

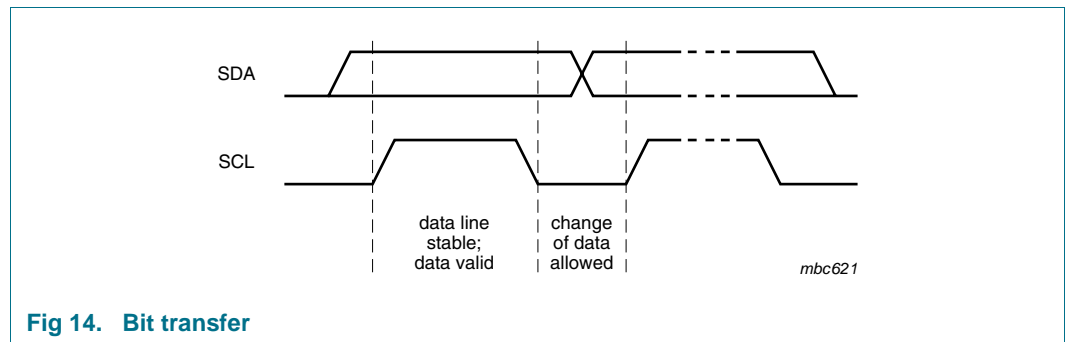

Fig 14. Bit transfer

7.7.2 START and STOP conditions

Both data and clock lines remain HIGH when the bus is not busy.

A HIGH-to-LOW transition of the data line while the clock is HIGH is defined as the START condition (S).

A LOW-to-HIGH transition of the data line while the clock is HIGH is defined as the STOP condition (P) (see [Figure 15](#)).

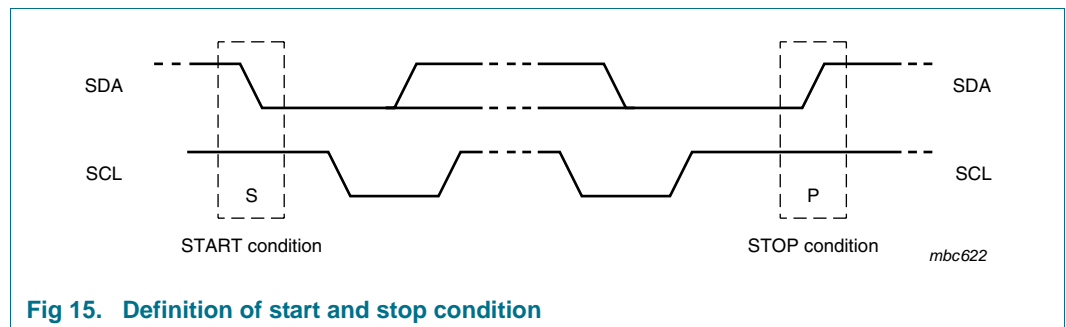

Fig 15. Definition of start and stop condition

7.7.3 System configuration

A device which sends data to the bus is a transmitter, a device which receives data from the bus is a receiver. The device which initiates and terminates a transfer is the master; and the devices which are addressed by the master are the slaves (see Figure 16).

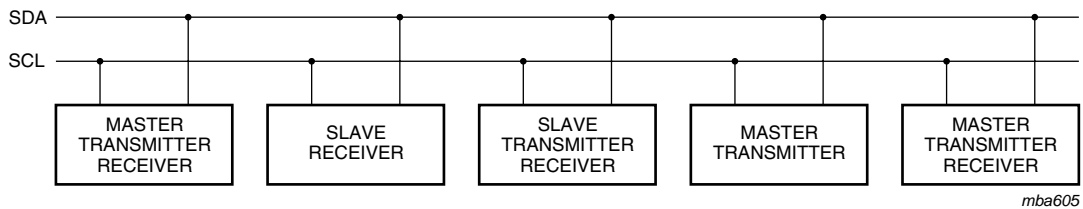

Fig 16. System configuration

7.7.4 Acknowledge

The number of data bytes transferred between the START and STOP conditions from transmitter to receiver is unlimited. Each byte of eight bits is followed by an acknowledge cycle.

- A slave receiver, which is addressed, must generate an acknowledge after the reception of each byte.
- A master receiver must generate an acknowledge after the reception of each byte that has been clocked out of the slave transmitter.
- The device that acknowledges must pull-down the SDA line during the acknowledge clock pulse, so that the SDA line is stable LOW during the HIGH period of the acknowledge related clock pulse (set-up and hold times must be taken into consideration).
- A master receiver must signal an end of data to the transmitter by not generating an acknowledge on the last byte that has been clocked out of the slave. In this event, the transmitter must leave the data line HIGH to enable the master to generate a STOP condition.

Acknowledgement on the I²C-bus is illustrated in Figure 17.

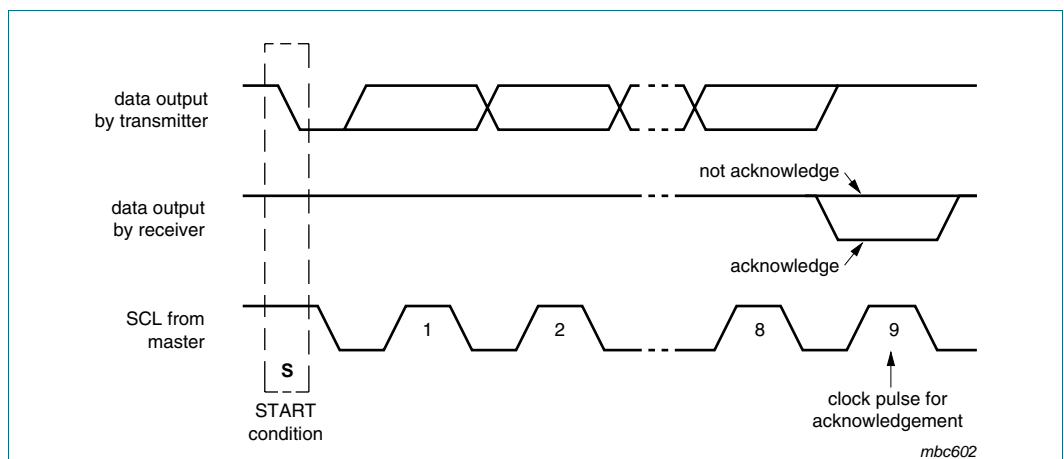

Fig 17. Acknowledgement on the I²C-bus

7.7.5 I²C-bus protocol

After a start condition a valid hardware address has to be sent to a PCA9691 device. The read/write bit defines the direction of the following single or multiple byte data transfer. For the format and the timing of the start condition (S), the stop condition (P) and the acknowledge bit (A) refer to the I²C-bus characteristics. In the write mode a data transfer is terminated by sending either a stop condition or the start condition of the next data transfer.

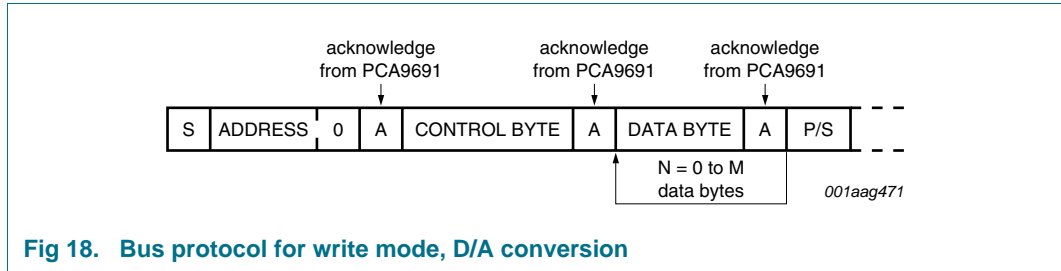

Fig 18. Bus protocol for write mode, D/A conversion

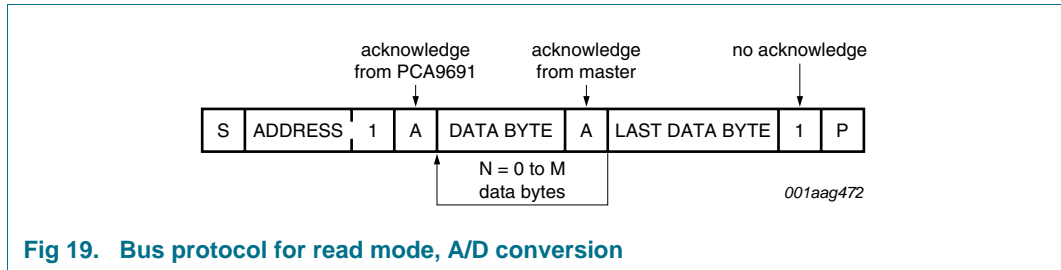

Fig 19. Bus protocol for read mode, A/D conversion

8. Internal circuitry

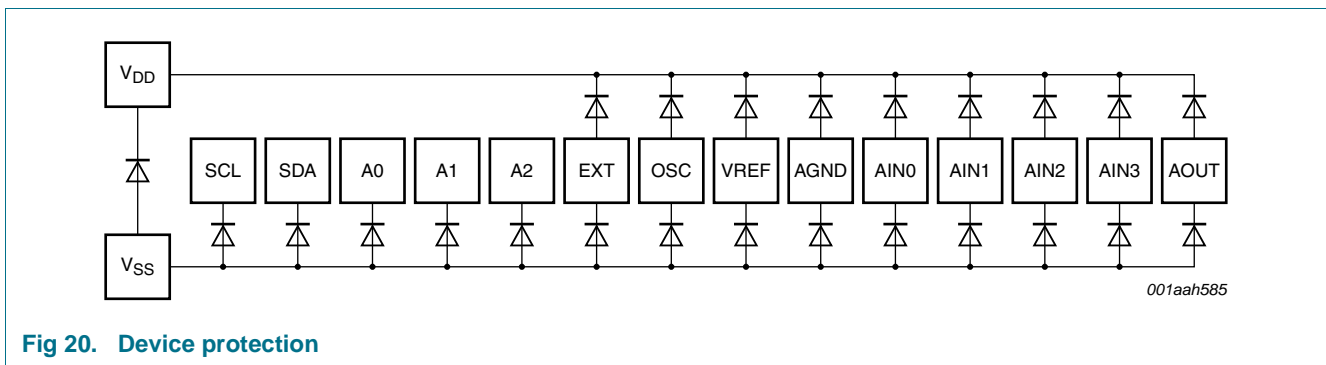

Fig 20. Device protection

9. Limiting values

Table 5. Limiting values

In accordance with the Absolute Maximum Rating System (IEC 60134).

Symbol	Parameter	Conditions	Min	Max	Unit
V _{DD}	supply voltage		-0.5	+6.5	V
V _I	input voltage		-0.5	V _{DD} + 0.5	V
I _I	input current		-	±10	mA

Table 5. Limiting values ...continued

In accordance with the Absolute Maximum Rating System (IEC 60134).

Symbol	Parameter	Conditions	Min	Max	Unit	
I_O	output current		-	±20	mA	
I_{DD}	supply current		-	+50	mA	
I_{SS}	ground supply current		-	-50	mA	
P_{tot}	total power dissipation		-	300	mW	
P_o	output power		-	100	mW	
V_{ESD}	electrostatic discharge voltage	HBM	[1]	-	±1500	V
		MM	[2]	-	±200	V
I_{lu}	latch-up current		[3]	-	100	mA
T_{stg}	storage temperature		[4]	-65	+150	°C
T_{amb}	ambient temperature			-40	+85	°C

[1] Pass level; Human Body Model (HBM), according to [Ref. 5 "JESD22-A114"](#).[2] Pass level; Machine Model (MM), according to [Ref. 6 "JESD22-A115"](#).[3] Pass level; latch-up testing according to [Ref. 7 "JESD78"](#) at maximum ambient temperature ($T_{amb(max)}$).[4] According to the NXP store and transport requirements (see [Ref. 9 "NX3-00092"](#)) the devices have to be stored at a temperature of +8 °C to +45 °C and a humidity of 25 % to 75 %. For long term storage products deviant conditions are described in that document.

10. Characteristics

10.1 Static characteristics

Table 6. Static characteristic $V_{DD} = 2.5\text{ V to }5.5\text{ V}$; $V_{SS} = 0\text{ V}$; $T_{amb} = -40\text{ °C to }+85\text{ °C}$; unless otherwise specified.

Symbol	Parameter	Conditions	Min	Typ	Max	Unit	
Supply							
V_{DD}	supply voltage		2.5	5.0	5.5	V	
I_{DD}	supply current	$V_I = V_{SS}$ or V_{DD} ; no load standby					
		no bus activity	-	1.5	10	µA	
		bus activity	-	10	100	µA	
		operating; $f_{SCL} = 1\text{ MHz}$					
		pin AOUT off	-	500	1400	µA	
pin AOUT active	-	1400	2500	µA			
V_{POR}	power-on reset voltage		[1]	0.8	-	2.0	V
Digital inputs: pins SCL, SDA, A0, A1, A2, OSC and EXT							
V_{IL}	LOW-level input voltage		0	-	$0.3V_{DD}$	V	
V_{IH}	HIGH-level input voltage		$0.7V_{DD}$	-	-	V	
I_L	leakage current	$V_I = V_{SS}$ to V_{DD}	-100	-	+100	nA	
C_i	input capacitance		-	-	550	pF	
Digital output: pin SDA							
I_{OL}	LOW-level output current	$V_{OL} = 0.4\text{ V}$; $V_{DD} = 5\text{ V}$; $C_L = 550\text{ pF}$; $f_{SCL} = 1\text{ MHz}$	24	-	-	mA	

Table 6. Static characteristic ...continued
 $V_{DD} = 2.5\text{ V to }5.5\text{ V}$; $V_{SS} = 0\text{ V}$; $T_{amb} = -40\text{ }^{\circ}\text{C to }+85\text{ }^{\circ}\text{C}$; unless otherwise specified.

Symbol	Parameter	Conditions	Min	Typ	Max	Unit
Reference inputs: pins VREF and AGND						
V_{VREF}	voltage on pin VREF	$V_{VREF} - V_{AGND} \geq 1.6\text{ V}$	1.6	-	V_{DD}	V
V_{AGND}	voltage on pin AGND	$V_{VREF} - V_{AGND} \geq 1.6\text{ V}$	V_{SS}	-	$V_{DD} - 1.6$	V
I_{LI}	input leakage current		-100	-	+100	nA
R_{ref}	reference resistance	resistance between pin VREF and pin AGND	-	40	-	k Ω
Oscillator: pin OSC						
$f_{osc(int)}$	internal oscillator frequency	pin EXT is LOW	3.2	-	8.0	MHz
$f_{osc(ext)}$	external oscillator frequency	pin EXT is HIGH	3.5	-	5.5	MHz

[1] The power-on reset circuit resets the I²C-bus logic when $V_{DD} < V_{POR}$.

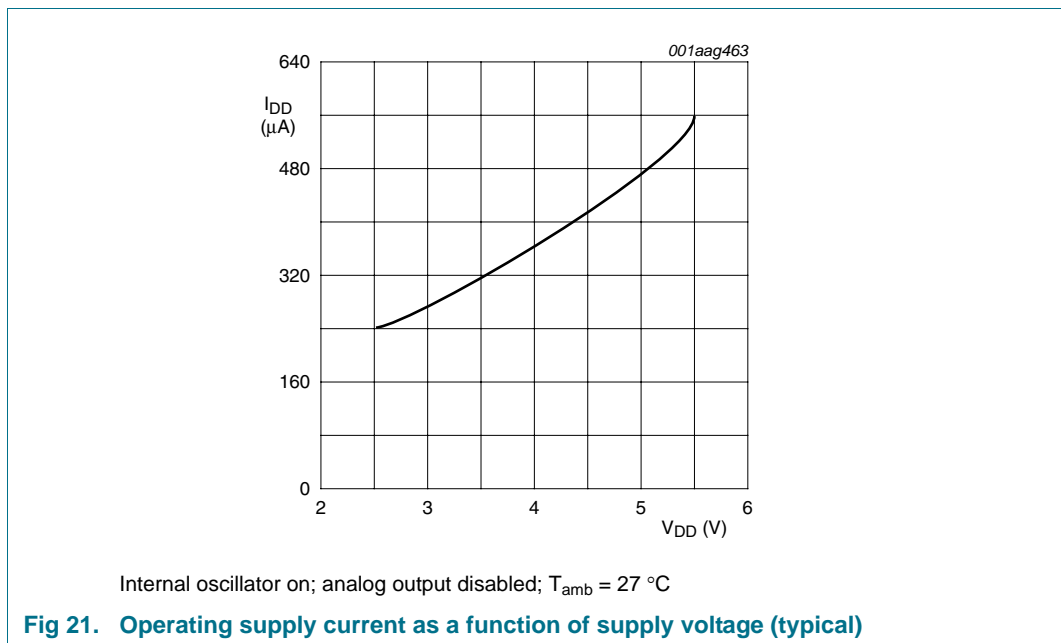

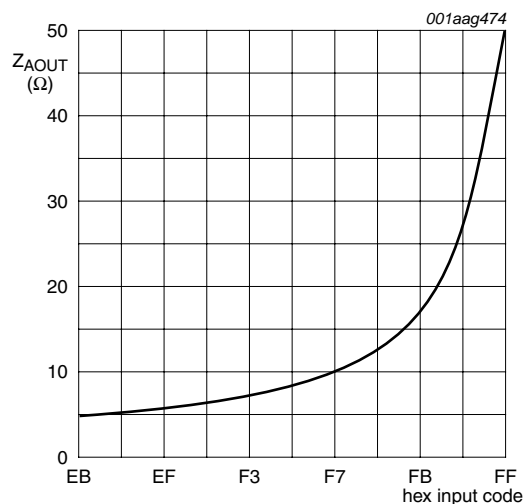
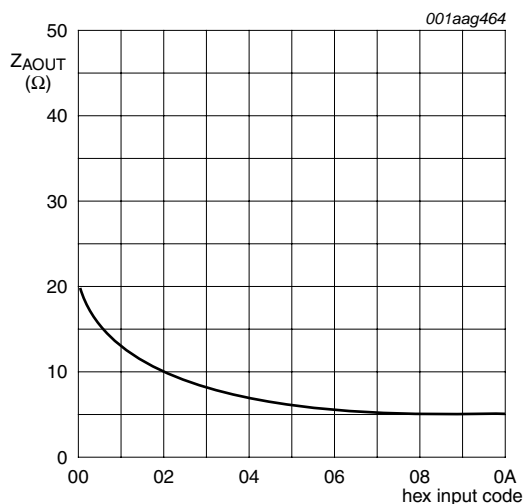

a. Output impedance near negative power rail (V_{SS}) b. Output impedance near positive power rail (V_{DD})
 $T_{amb} = 27\text{ °C}$; $V_{DD} = 5\text{ V}$; $V_{VREF} = 5\text{ V}$; $V_{AGND} = 0\text{ V}$, (typical values)

Fig 22. Output impedance of analog output buffer (near power rails)

10.2 Dynamic characteristics

Table 7. I²C-bus characteristics

$V_{DD} = 2.5\text{ V to }5.5\text{ V}$; $V_{SS} = 0\text{ V}$; $T_{amb} = -40\text{ °C to }+85\text{ °C}$; reference to 30 % and 70 % with an input voltage swing of V_{SS} to V_{DD} (see [Figure 23](#)).

Symbol	Parameter	Conditions	Standard mode		Fast mode		Fast-mode Plus		Unit
			Min	Max	Min	Max	Min	Max	
f _{SCL}	SCL clock frequency	[1]	0	100	0	400	0	1000	kHz
t _{BUF}	bus free time between a STOP and START condition		4.7	-	1.3	-	0.5	-	μs
t _{HD;STA}	hold time (repeated) START condition		4.0	-	0.6	-	0.26	-	μs
t _{SU;STA}	set-up time for a repeated START condition		4.7	-	0.6	-	0.26	-	μs
t _{SU;STO}	set-up time for STOP condition		4.0	-	0.6	-	0.26	-	μs
t _{HD;DAT}	data hold time		0	-	0	-	0	-	ns
t _{VD;ACK}	data valid acknowledge time	[2]	0.1	3.45	0.1	0.9	0.05	0.45	μs
t _{VD;DAT}	data valid time	[3]	300	-	75	-	75	450	ns
t _{SU;DAT}	data set-up time		250	-	100	-	50	-	ns
t _{LOW}	LOW period of the SCL clock		4.7	-	1.3	-	0.5	-	μs
t _{HIGH}	HIGH period of the SCL clock		4.0	-	0.6	-	0.26	-	μs

Table 7. I²C-bus characteristics ...continued

$V_{DD} = 2.5\text{ V to }5.5\text{ V}$; $V_{SS} = 0\text{ V}$; $T_{amb} = -40\text{ }^{\circ}\text{C to }+85\text{ }^{\circ}\text{C}$; reference to 30 % and 70 % with an input voltage swing of V_{SS} to V_{DD} (see [Figure 23](#)).

Symbol	Parameter	Conditions	Standard mode		Fast mode		Fast-mode Plus		Unit
			Min	Max	Min	Max	Min	Max	
t_f	fall time of both SDA and SCL signals	[4][5][6]	-	300	$20 + 0.1C_b$	300	-	120	ns
t_r	rise time of both SDA and SCL signals	[4][5][6]	-	1000	$20 + 0.1C_b$	300	-	120	ns
$t_{w(\text{spike})}$	spike pulse width	[7]	-	50	-	50	-	50	ns

- [1] The minimum SCL clock frequency is limited by the bus time-out feature which resets the serial bus interface if either the SDA or SCL is held LOW for a minimum of 25 ms. You must disable the bus time-out feature for DC operation.
- [2] $t_{VD,ACK}$ = time for acknowledgement signal from SCL LOW to SDA (out) LOW.
- [3] $t_{VD,DAT}$ = minimum time for valid SDA (out) data following SCL LOW.
- [4] A master device must internally provide a hold time of at least 300 ns for the SDA signal (refer to the V_{IL} of the SCL signal) in order to bridge the undefined region of the SCL's falling edge.
- [5] C_b = total capacitance of one bus line in pF.
- [6] The maximum t_f for the SDA and SCL bus lines is 300 ns. The maximum fall time for the SDA output stage, t_f is 250 ns. This allows series protection resistors to be connected between the SDA pin and the SDA bus line and between the SCL pin and the SCL bus line without exceeding the maximum t_f .
- [7] Input filters on the SDA and SCL inputs suppress noise spikes of less than 50 ns.

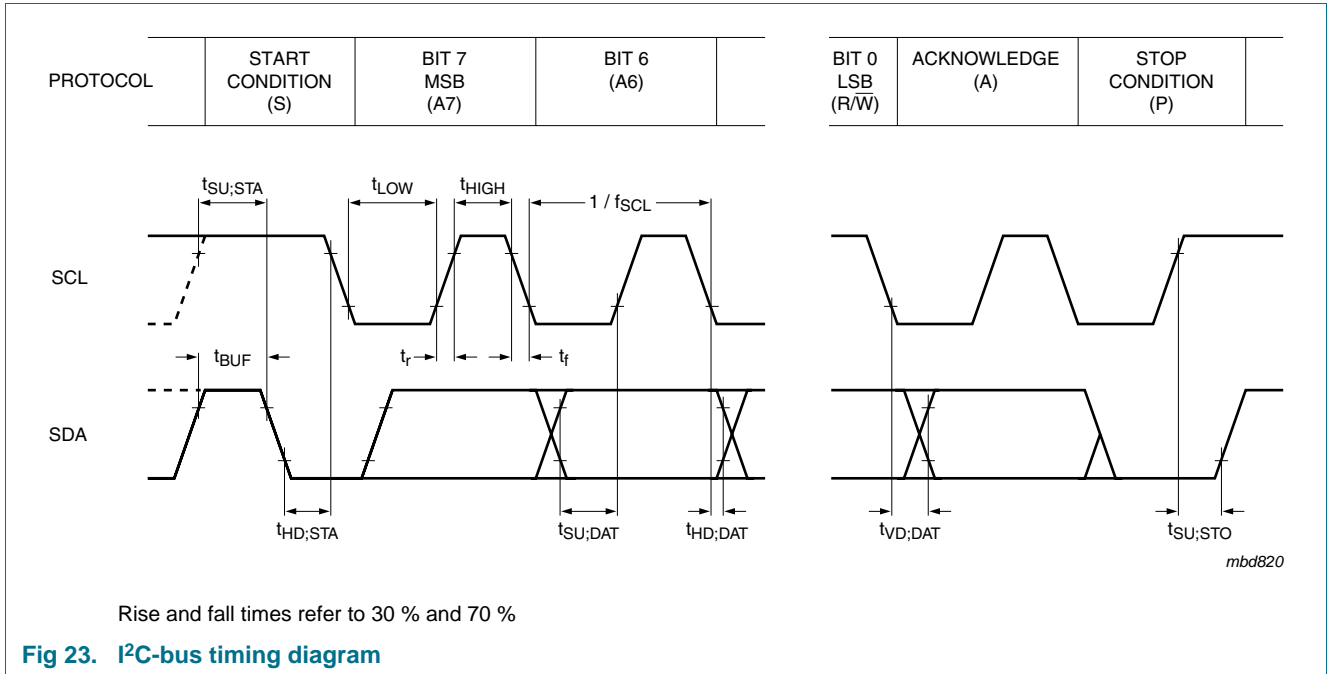

Table 8. D/A characteristics

$V_{DD} = 5.0\text{ V}$; $V_{SS} = 0\text{ V}$; $V_{VREF} = 5.0\text{ V}$; $V_{AGND} = 0\text{ V}$; $T_{amb} = -40\text{ °C to }+85\text{ °C}$; $R_L = 10\text{ k}\Omega$; $C_L = 50\text{ pF}$; unless otherwise specified.

Symbol	Parameter	Conditions	Min	Typ	Max	Unit
Analog output						
V_{AOUT}	voltage on pin AOUT	no resistive load	V_{SS}	-	V_{DD}	V
		$R_L = 10\text{ k}\Omega$	V_{SS}	-	$0.9V_{DD}$	V
I_{LO}	output leakage current	pin AOUT disabled	-100	-	+100	nA
Accuracy						
E_G	gain error	no resistive load	-	-	1	%
E_O	offset error		-	-	± 20	mV
E_L	linearity error	$f_{SCL} \leq 400\text{ kHz}$	[1]	-	± 1.0	LSB
		$f_{SCL} > 400\text{ kHz}$	[1]	-	± 1.5	LSB
$t_{s(DAC)}$	DAC settling time		[2]	-	2.4	μs
$f_{c(DAC)}$	DAC conversion frequency		-	-	44	kHz
$\alpha_{sup(n)}$	noise suppression	$f = 100\text{ Hz}$; $V_{n(VDD)(p-p)} = 100\text{ mV}$	-	40	-	dB

[1] The linearity error is assured if the internal frequency is changed by setting bit 7 and bit 3 of the control byte to logic 1 (see [Figure 6](#)).

[2] The time from the start of AOUT to a change of $\frac{1}{2}$ LSB full scale (see [Section 7.3](#)).

Table 9. A/D characteristics

$V_{DD} = 5.0\text{ V}$; $V_{SS} = 0\text{ V}$; $V_{VREF} = 5.0\text{ V}$; $V_{AGND} = 0\text{ V}$; $T_{amb} = -40\text{ °C to }+85\text{ °C}$; $R_L = 10\text{ k}\Omega$; $C_L = 50\text{ pF}$; unless otherwise specified.

Symbol	Parameter	Conditions	Min	Typ	Max	Unit
Analog inputs						
V_{AIN}	voltage on pin AIN	pins AIN0 to AIN3	V_{SS}	-	V_{DD}	V
I_{LI}	input leakage current		-100	-	+100	nA
$C_{i(a)}$	analog input capacitance		-	10	-	pF
$C_{i(dif)}$	differential input capacitance		-	10	-	pF
$V_{i(se)}$	single-ended input voltage	measuring range	V_{AGND}	-	V_{VREF}	V
$V_{i(dif)}$	differential input voltage	measuring range: $V_{FSR} = V_{VREF} - V_{AGND}$	$-0.5V_{FSR}$	-	$+0.5V_{FSR}$	V
Accuracy						
E_G	gain error	$f_{SCL} \leq 400\text{ kHz}$	-	-	1	%
		$f_{SCL} > 400\text{ kHz}$	-	-	3	%
E_O	offset error		-	-	± 20	mV
E_L	linearity error	$f_{SCL} \leq 400\text{ kHz}$	[1]	-	± 1.0	LSB
		$f_{SCL} > 400\text{ kHz}$	[1]	-	± 2.0	LSB
CMRR	common-mode rejection ratio		-	40	-	dB
$\alpha_{sup(n)}$	noise suppression	$f = 100\text{ Hz}$; $V_{n(VDD)(p-p)} = 100\text{ mV}$	-	40	-	dB
$t_{c(ADC)}$	ADC conversion time		-	-	8.5	μs
$f_{c(ADC)}$	ADC conversion frequency	$f_{SCL} = 1\text{ MHz}$	-	-	111	kHz

[1] The linearity error is assured if the internal frequency is changed by setting bit 7 and bit 3 of the control byte to logic 1 (see [Figure 6](#)).

11. Application information

Inputs must be connected to V_{SS} or V_{DD} when not in use. Analog inputs may also be connected to pins AGND or VREF.

In order to prevent excessive ground and supply noise and to minimize crosstalk of the digital-to-analog signal paths the printed-circuit board layout must be designed very carefully. Noisy digital circuits and ground loops must be avoided on the supply lines common to the PCA9691 device. Decoupling capacitors ($> 10 \mu\text{F}$) are recommended for power supply and reference voltage inputs.

During data transfer the first bit written out is the MSB and the last bit is the LSB.

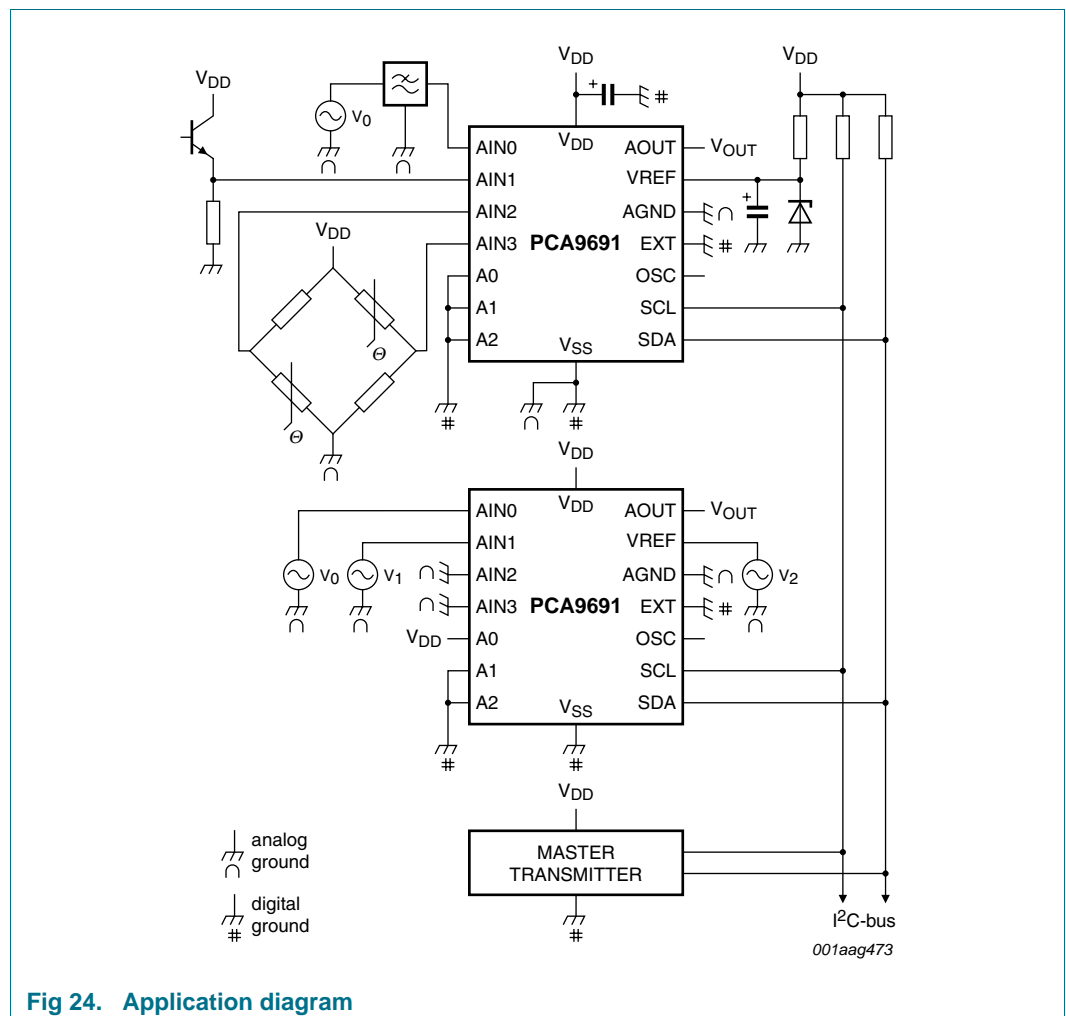
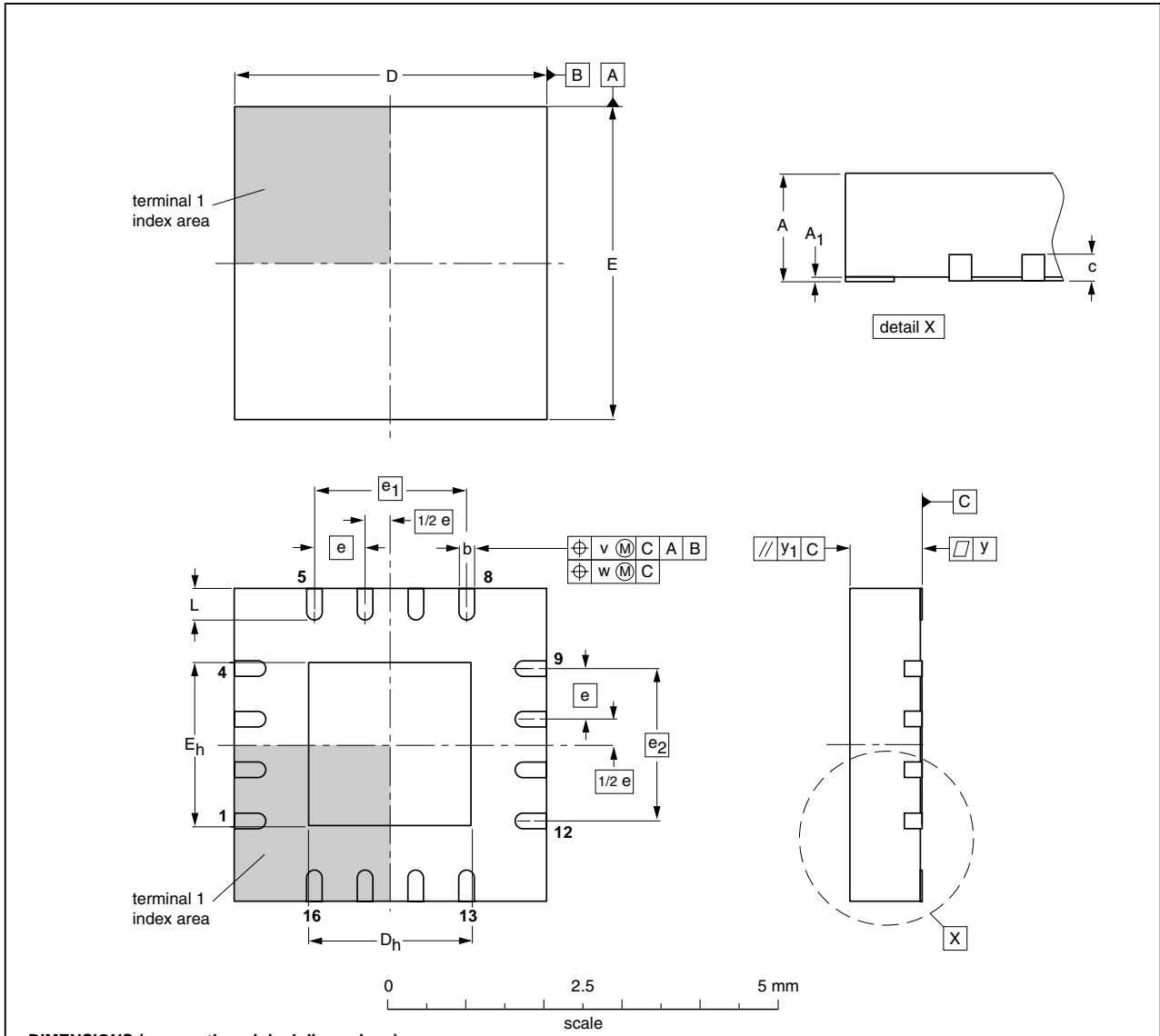

Fig 24. Application diagram

12. Package outline

HVQFN16: plastic thermal enhanced very thin quad flat package; no leads; 16 terminals; body 4 x 4 x 0.85 mm

SOT629-1



DIMENSIONS (mm are the original dimensions)

UNIT	A ⁽¹⁾ max.	A ₁	b	c	D ⁽¹⁾	D _h	E ⁽¹⁾	E _h	e	e ₁	e ₂	L	v	w	y	y ₁
mm	1	0.05 0.00	0.38 0.23	0.2	4.1 3.9	2.25 1.95	4.1 3.9	2.25 1.95	0.65	1.95	1.95	0.75 0.50	0.1	0.05	0.05	0.1

Note

1. Plastic or metal protrusions of 0.075 mm maximum per side are not included.

OUTLINE VERSION	REFERENCES				EUROPEAN PROJECTION	ISSUE DATE
	IEC	JEDEC	JEITA			
SOT629-1	---	MO-220	---			01-08-08- 02-10-22

Fig 25. Package outline SOT629-1 (HVQFN16) of PCA9691BS

TSSOP16: plastic thin shrink small outline package; 16 leads; body width 4.4 mm

SOT403-1

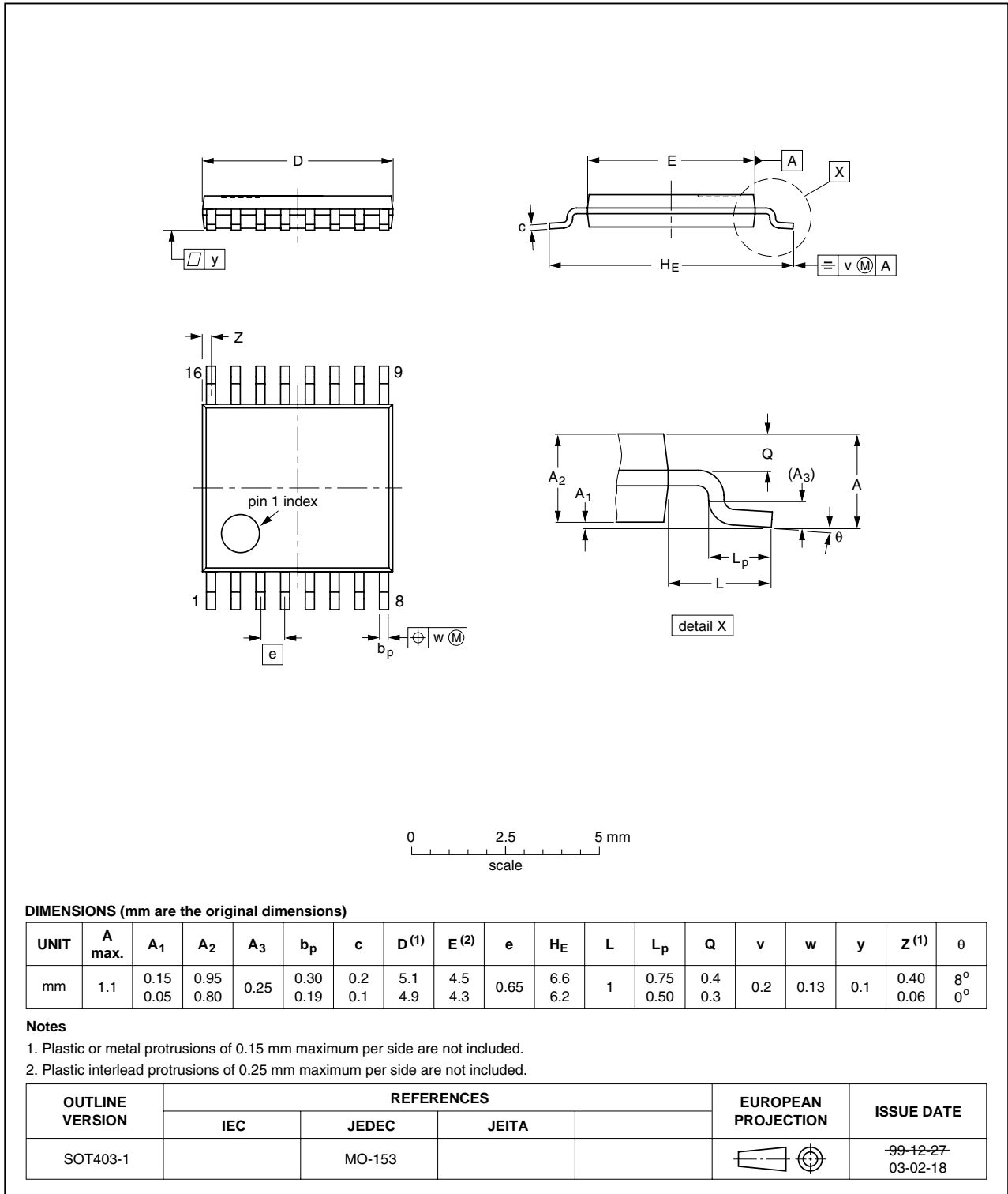

Fig 26. Package outline SOT403-1 (TSSOP16) of PCA9691TS

SO16: plastic small outline package; 16 leads; body width 7.5 mm

SOT162-1

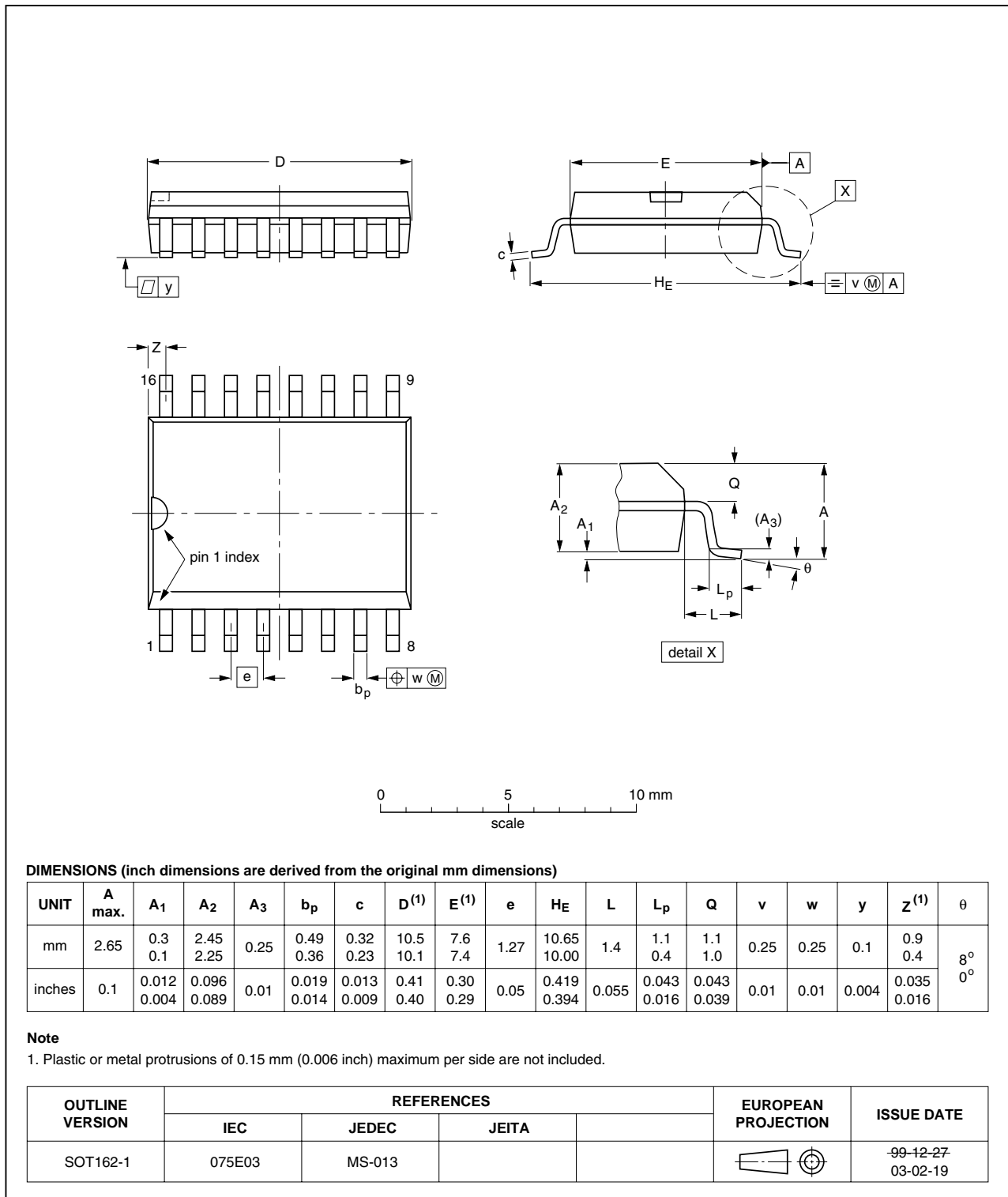

Fig 27. Package outline SOT162-1 (SO16) of PCA9691T

13. Soldering of SMD packages

This text provides a very brief insight into a complex technology. A more in-depth account of soldering ICs can be found in Application Note *AN10365 "Surface mount reflow soldering description"*.

13.1 Introduction to soldering

Soldering is one of the most common methods through which packages are attached to Printed Circuit Boards (PCBs), to form electrical circuits. The soldered joint provides both the mechanical and the electrical connection. There is no single soldering method that is ideal for all IC packages. Wave soldering is often preferred when through-hole and Surface Mount Devices (SMDs) are mixed on one printed wiring board; however, it is not suitable for fine pitch SMDs. Reflow soldering is ideal for the small pitches and high densities that come with increased miniaturization.

13.2 Wave and reflow soldering

Wave soldering is a joining technology in which the joints are made by solder coming from a standing wave of liquid solder. The wave soldering process is suitable for the following:

- Through-hole components
- Leaded or leadless SMDs, which are glued to the surface of the printed circuit board

Not all SMDs can be wave soldered. Packages with solder balls, and some leadless packages which have solder lands underneath the body, cannot be wave soldered. Also, leaded SMDs with leads having a pitch smaller than ~0.6 mm cannot be wave soldered, due to an increased probability of bridging.

The reflow soldering process involves applying solder paste to a board, followed by component placement and exposure to a temperature profile. Leaded packages, packages with solder balls, and leadless packages are all reflow solderable.

Key characteristics in both wave and reflow soldering are:

- Board specifications, including the board finish, solder masks and vias
- Package footprints, including solder thieves and orientation
- The moisture sensitivity level of the packages
- Package placement
- Inspection and repair
- Lead-free soldering versus SnPb soldering

13.3 Wave soldering

Key characteristics in wave soldering are:

- Process issues, such as application of adhesive and flux, clinching of leads, board transport, the solder wave parameters, and the time during which components are exposed to the wave
- Solder bath specifications, including temperature and impurities

13.4 Reflow soldering

Key characteristics in reflow soldering are:

- Lead-free versus SnPb soldering; note that a lead-free reflow process usually leads to higher minimum peak temperatures (see [Figure 28](#)) than a SnPb process, thus reducing the process window
- Solder paste printing issues including smearing, release, and adjusting the process window for a mix of large and small components on one board
- Reflow temperature profile; this profile includes preheat, reflow (in which the board is heated to the peak temperature) and cooling down. It is imperative that the peak temperature is high enough for the solder to make reliable solder joints (a solder paste characteristic). In addition, the peak temperature must be low enough that the packages and/or boards are not damaged. The peak temperature of the package depends on package thickness and volume and is classified in accordance with [Table 10](#) and [11](#)

Table 10. SnPb eutectic process (from J-STD-020C)

Package thickness (mm)	Package reflow temperature (°C)	
	Volume (mm ³)	
	< 350	≥ 350
< 2.5	235	220
≥ 2.5	220	220

Table 11. Lead-free process (from J-STD-020C)

Package thickness (mm)	Package reflow temperature (°C)		
	Volume (mm ³)		
	< 350	350 to 2000	> 2000
< 1.6	260	260	260
1.6 to 2.5	260	250	245
> 2.5	250	245	245

Moisture sensitivity precautions, as indicated on the packing, must be respected at all times.

Studies have shown that small packages reach higher temperatures during reflow soldering, see [Figure 28](#).

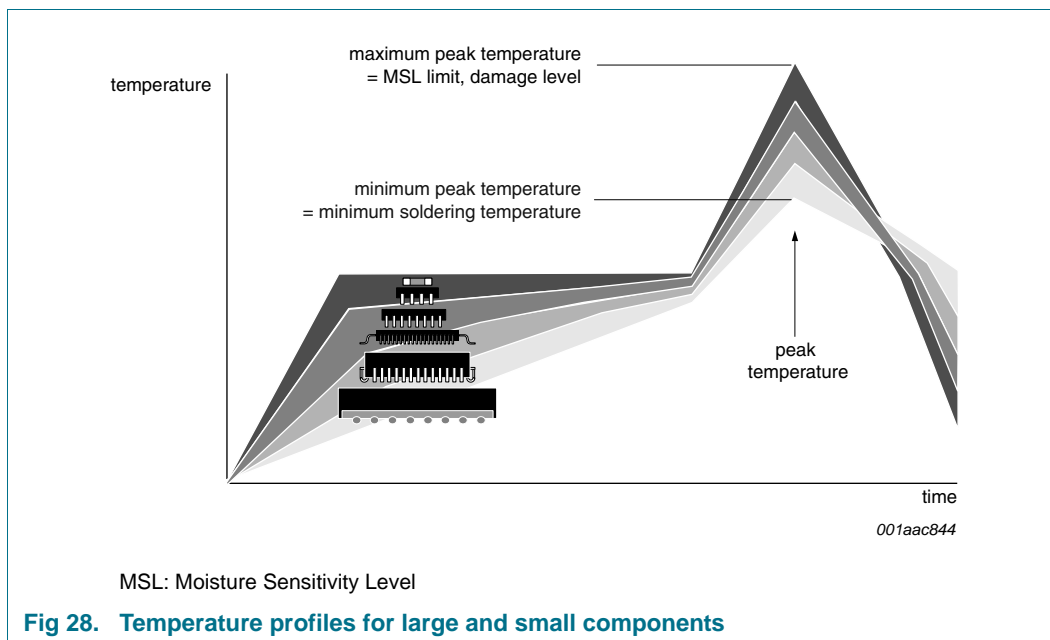

For further information on temperature profiles, refer to Application Note AN10365 “Surface mount reflow soldering description”.

14. Abbreviations

Table 12. Abbreviations

Acronym	Description
CMOS	Complementary Metal Oxide Semiconductor
DAC	Digital-to-Analog Converter
DC	Direct Current
HBM	Human Body Model
I ² C	Inter-Integrated Circuit bus
IC	Integrated Circuit
LSB	Least Significant Bit
MM	Machine Model
MSB	Most Significant Bit
MSL	Moisture Sensitivity Level
PCB	Printed-Circuit Board
POR	Power-On Reset
SCL	Serial Clock Line
SDA	Serial DATA line
SMD	Surface Mount Device

15. References

- [1] AN10365 — Surface mount reflow soldering description

- [2] **IEC 60134** — Rating systems for electronic tubes and valves and analogous semiconductor devices
- [3] **IEC 61340-5** — Protection of electronic devices from electrostatic phenomena
- [4] **IPC/JEDEC J-STD-020D** — Moisture/Reflow Sensitivity Classification for Nonhermetic Solid State Surface Mount Devices
- [5] **JESD22-A114** — Electrostatic Discharge (ESD) Sensitivity Testing Human Body Model (HBM)
- [6] **JESD22-A115** — Electrostatic Discharge (ESD) Sensitivity Testing Machine Model (MM)
- [7] **JESD78** — IC Latch-Up Test
- [8] **JESD625-A** — Requirements for Handling Electrostatic-Discharge-Sensitive (ESDS) Devices
- [9] **NX3-00092** — NXP store and transport requirements
- [10] **SNV-FA-01-02** — Marking Formats Integrated Circuits
- [11] **UM10204** — I²C-bus specification and user manual

16. Revision history

Table 13. Revision history

Document ID	Release date	Data sheet status	Change notice	Supersedes
PCA9691_2	20100127	Product data sheet		PCA9691_1
Modifications:	<ul style="list-style-type: none"> • Added new package and product type PCA9691T 			
PCA9691_1	20080408	Product data sheet	-	-

17. Legal information

17.1 Data sheet status

Document status ^{[1][2]}	Product status ^[3]	Definition
Objective [short] data sheet	Development	This document contains data from the objective specification for product development.
Preliminary [short] data sheet	Qualification	This document contains data from the preliminary specification.
Product [short] data sheet	Production	This document contains the product specification.

[1] Please consult the most recently issued document before initiating or completing a design.

[2] The term 'short data sheet' is explained in section "Definitions".

[3] The product status of device(s) described in this document may have changed since this document was published and may differ in case of multiple devices. The latest product status information is available on the Internet at URL <http://www.nxp.com>.

17.2 Definitions

Draft — The document is a draft version only. The content is still under internal review and subject to formal approval, which may result in modifications or additions. NXP Semiconductors does not give any representations or warranties as to the accuracy or completeness of information included herein and shall have no liability for the consequences of use of such information.

Short data sheet — A short data sheet is an extract from a full data sheet with the same product type number(s) and title. A short data sheet is intended for quick reference only and should not be relied upon to contain detailed and full information. For detailed and full information see the relevant full data sheet, which is available on request via the local NXP Semiconductors sales office. In case of any inconsistency or conflict with the short data sheet, the full data sheet shall prevail.

17.3 Disclaimers

General — Information in this document is believed to be accurate and reliable. However, NXP Semiconductors does not give any representations or warranties, expressed or implied, as to the accuracy or completeness of such information and shall have no liability for the consequences of use of such information.

Right to make changes — NXP Semiconductors reserves the right to make changes to information published in this document, including without limitation specifications and product descriptions, at any time and without notice. This document supersedes and replaces all information supplied prior to the publication hereof.

Suitability for use — NXP Semiconductors products are not designed, authorized or warranted to be suitable for use in medical, military, aircraft, space or life support equipment, nor in applications where failure or malfunction of an NXP Semiconductors product can reasonably be expected to result in personal injury, death or severe property or environmental

damage. NXP Semiconductors accepts no liability for inclusion and/or use of NXP Semiconductors products in such equipment or applications and therefore such inclusion and/or use is at the customer's own risk.

Applications — Applications that are described herein for any of these products are for illustrative purposes only. NXP Semiconductors makes no representation or warranty that such applications will be suitable for the specified use without further testing or modification.

Limiting values — Stress above one or more limiting values (as defined in the Absolute Maximum Ratings System of IEC 60134) may cause permanent damage to the device. Limiting values are stress ratings only and operation of the device at these or any other conditions above those given in the Characteristics sections of this document is not implied. Exposure to limiting values for extended periods may affect device reliability.

Terms and conditions of sale — NXP Semiconductors products are sold subject to the general terms and conditions of commercial sale, as published at <http://www.nxp.com/profile/terms>, including those pertaining to warranty, intellectual property rights infringement and limitation of liability, unless explicitly otherwise agreed to in writing by NXP Semiconductors. In case of any inconsistency or conflict between information in this document and such terms and conditions, the latter will prevail.

No offer to sell or license — Nothing in this document may be interpreted or construed as an offer to sell products that is open for acceptance or the grant, conveyance or implication of any license under any copyrights, patents or other industrial or intellectual property rights.

Export control — This document as well as the item(s) described herein may be subject to export control regulations. Export might require a prior authorization from national authorities.

17.4 Trademarks

Notice: All referenced brands, product names, service names and trademarks are the property of their respective owners.

I²C-bus — logo is a trademark of NXP B.V.

18. Contact information

For more information, please visit: <http://www.nxp.com>

For sales office addresses, please send an email to: salesaddresses@nxp.com

19. Contents

1	General description	1	19	Contents	31
2	Features	1			
3	Ordering information	2			
4	Marking	2			
5	Block diagram	2			
6	Pinning information	3			
6.1	Pinning	3			
6.2	Pin description	4			
7	Functional description	4			
7.1	Addressing	4			
7.1.1	Address map	5			
7.2	Control byte	6			
7.3	D/A conversion	8			
7.3.1	Worst case example	10			
7.4	A/D conversion	11			
7.5	Reference voltage	13			
7.6	Oscillator	13			
7.7	Characteristics of the I ² C-bus	14			
7.7.1	Bit transfer	14			
7.7.2	START and STOP conditions	14			
7.7.3	System configuration	15			
7.7.4	Acknowledge	15			
7.7.5	I ² C-bus protocol	16			
8	Internal circuitry	16			
9	Limiting values	16			
10	Characteristics	17			
10.1	Static characteristics	17			
10.2	Dynamic characteristics	19			
11	Application information	22			
12	Package outline	23			
13	Soldering of SMD packages	26			
13.1	Introduction to soldering	26			
13.2	Wave and reflow soldering	26			
13.3	Wave soldering	26			
13.4	Reflow soldering	27			
14	Abbreviations	28			
15	References	28			
16	Revision history	29			
17	Legal information	30			
17.1	Data sheet status	30			
17.2	Definitions	30			
17.3	Disclaimers	30			
17.4	Trademarks	30			
18	Contact information	30			

Please be aware that important notices concerning this document and the product(s) described herein, have been included in section 'Legal information'.

founded by

PHILIPS

© NXP B.V. 2010.

All rights reserved.

For more information, please visit: <http://www.nxp.com>

For sales office addresses, please send an email to: salesaddresses@nxp.com

Date of release: 27 January 2010

Document identifier: PCA9691_2

Looking for pricing, stock, or lifecycle information?

Click below to explore more details on WIN SOURCE:

- ⊖ [View PCA9691TS/1,118 on WIN SOURCE](#)
- ⊖ [NXP / Nexperia Information](#)

Optimize Your Supply Chain with WIN SOURCE Solutions

- ✓ Global Sourcing Solution
- ✓ Obsolete Management
- ✓ Cost Control Management
- ✓ Shortage Management
- ✓ Alternative Solution
- ✓ Excess Inventory Management