

SIEMENS



ICs for Communications

Extended PCM Interface Controller

EPIC®-1

PEB 2055 / PEF 2055 Versions A3

EPIC®-S

PEB 2054 / PEF 2054 Versions 1.0

User's Manual 02.97

| | | |
|----------------------------|-------------------------|--|
| PEB 2055 | | |
| PEF 2055 | | |
| Revision History: | | User's Manual 02.97 |
| Previous Release: | | Technical Manual 02.92 (Editorial Update) |
| Page (in Previous Release) | Page (in User's Manual) | Subjects (major changes since last revision) |

Edition 02.97

This edition was realized using the software system FrameMaker®.

**Published by Siemens AG,
Bereich Halbleiter, Marketing-
Kommunikation, Balanstraße 73,
81541 München**

© Siemens AG 7/23/97.

All Rights Reserved.

Attention please!

As far as patents or other rights of third parties are concerned, liability is only assumed for components, not for applications, processes and circuits implemented within components or assemblies.

The information describes the type of component and shall not be considered as assured characteristics.

Terms of delivery and rights to change design reserved.

For questions on technology, delivery and prices please contact the Semiconductor Group Offices in Germany or the Siemens Companies and Representatives worldwide (see address list).

Due to technical requirements components may contain dangerous substances. For information on the types in question please contact your nearest Siemens Office, Semiconductor Group.

Siemens AG is an approved CECC manufacturer.

Packing

Please use the recycling operators known to you. We can also help you – get in touch with your nearest sales office. By agreement we will take packing material back, if it is sorted. You must bear the costs of transport.

For packing material that is returned to us unsorted or which we are not obliged to accept, we shall have to invoice you for any costs incurred.

Components used in life-support devices or systems must be expressly authorized for such purpose!

Critical components¹ of the Semiconductor Group of Siemens AG, may only be used in life-support devices or systems² with the express written approval of the Semiconductor Group of Siemens AG.

- 1 A critical component is a component used in a life-support device or system whose failure can reasonably be expected to cause the failure of that life-support device or system, or to affect its safety or effectiveness of that device or system.
- 2 Life support devices or systems are intended (a) to be implanted in the human body, or (b) to support and/or maintain and sustain human life. If they fail, it is reasonable to assume that the health of the user may be endangered.

| Table of Contents | | Page |
|--------------------------|---|-------------|
| 1 | Overview | 7 |
| 1.1 | Features | 8 |
| 1.2 | Pin Configuration | 9 |
| 1.3 | Pin Definitions and Functions | 11 |
| 1.4 | Logic Symbols | 14 |
| 1.5 | Functional Block Diagram | 16 |
| 1.6 | Using the EPIC-S | 17 |
| 1.7 | System Integration and Application | 18 |
| 1.7.1 | Digital Line Card | 18 |
| 1.7.1.1 | Switching, Layer-1 Control | 18 |
| 1.7.1.2 | Decentralized D-Channel Handling | 18 |
| 1.7.1.3 | Central D-Channel Processing | 20 |
| 1.7.1.4 | Mixed D-Channel Processing, Signaling Decentralized, Packet Data Centralized | 21 |
| 1.7.2 | Analog Line Card | 23 |
| 1.7.3 | Packet Handlers | 24 |
| 2 | Functional Description | 27 |
| 2.1 | Bus Interface | 27 |
| 2.2 | PCM Interface | 28 |
| 2.3 | Configurable Interface | 29 |
| 2.4 | Memory Structure and Switching | 29 |
| 2.5 | Pre-processed Channels, Layer-1 Support | 31 |
| 2.6 | Special Functions | 31 |
| 3 | Operational Description | 32 |
| 3.1 | Microprocessor Interface Operation | 32 |
| 3.2 | Clocking | 33 |
| 3.3 | Reset | 33 |
| 3.4 | EPIC® Operation | 34 |
| 3.4.1 | PCM-Interface | 35 |
| 3.4.2 | Configurable Interface | 36 |
| 3.4.3 | Switching Functions | 38 |
| 3.4.4 | Special Functions | 41 |
| 3.5 | Initialization Procedure | 42 |
| 3.5.1 | Hardware Reset | 42 |
| 3.5.2 | EPIC® Initialization | 42 |
| 3.5.2.1 | Register Initialization | 42 |
| 3.5.2.2 | Control Memory Reset | 42 |
| 3.5.2.3 | Initialization of Pre-processed Channels | 43 |
| 3.5.2.4 | Initialization of the Upstream Data Memory (DM) Tristate Field | 45 |
| 3.5.3 | Activation of the PCM and CFI Interfaces | 45 |

| Table of Contents | | Page |
|--------------------------|---|-------------|
| 4 | Detailed Register Description | 46 |
| 4.1 | Register Address Arrangement | 46 |
| 4.2 | Detailed Register Description | 48 |
| 4.2.1 | PCM Interface Registers | 48 |
| 4.2.1.1 | PCM-Mode Register (PMOD) | 48 |
| 4.2.1.2 | Bit Number per PCM-Frame (PBNR) | 50 |
| 4.2.1.3 | PCM-Offset Downstream Register (POFD) | 50 |
| 4.2.1.4 | PCM-Offset Upstream Register (POFU) | 51 |
| 4.2.1.5 | PCM-Clock Shift Register (PCSR) | 51 |
| 4.2.1.6 | PCM-Input Comparison Mismatch (PICM) | 52 |
| 4.2.2 | Configurable Interface Registers | 53 |
| 4.2.2.1 | Configurable Interface Mode Register 1 (CMD1) | 53 |
| 4.2.2.2 | Configurable Interface Mode Register 2 (CMD2) | 55 |
| 4.2.2.3 | Configurable Interface Bit Number Register (CBNR) | 58 |
| 4.2.2.4 | Configurable Interface Time Slot Adjustment Register (CTAR) | 58 |
| 4.2.2.5 | Configurable Interface Bit Shift Register (CBSR) | 59 |
| 4.2.2.6 | Configurable Interface Subchannel Register (CSCR) | 60 |
| 4.2.3 | Memory Access Registers | 61 |
| 4.2.3.1 | Memory Access Control Register (MACR) | 61 |
| 4.2.3.2 | Memory Access Address Register (MAAR) | 65 |
| 4.2.3.3 | Memory Access Data Register (MADR) | 66 |
| 4.2.4 | Synchronous Transfer Registers | 67 |
| 4.2.4.1 | Synchronous Transfer Data Register (STDA) | 67 |
| 4.2.4.2 | Synchronous Transfer Data Register B (STDB) | 67 |
| 4.2.4.3 | Synchronous Transfer Receive Address Register A (SARA) | 68 |
| 4.2.4.4 | Synchronous Transfer Receive Address Register B (SARB) | 69 |
| 4.2.4.5 | Synchronous Transfer Transmit Address Register A (SAXA) | 69 |
| 4.2.4.6 | Synchronous Transfer Transmit Address Register B (SAXB) | 70 |
| 4.2.4.7 | Synchronous Transfer Control Register (STCR) | 70 |
| 4.2.5 | Monitor/Feature Control Registers | 71 |
| 4.2.5.1 | MF-Channel Active Indication Register (MFAIR) | 71 |
| 4.2.5.2 | MF-Channel Subscriber Address Register (MFSAR) | 72 |
| 4.2.5.3 | Monitor/Feature Control Channel FIFO (MFFIFO) | 73 |
| 4.2.6 | Status/Control Registers | 73 |
| 4.2.6.1 | Signaling FIFO (CIFIFO) | 73 |
| 4.2.6.2 | Timer Register (TIMR) | 74 |
| 4.2.6.3 | Status Register (STAR) | 75 |
| 4.2.6.4 | Command Register (CMDR) | 76 |
| 4.2.6.5 | Interrupt Status Register (ISTA) | 78 |
| 4.2.6.6 | Mask Register (MASK) | 79 |
| 4.2.6.7 | Operation Mode Register (OMDR) | 80 |

| Table of Contents | | Page |
|--------------------------|--|-------------|
| 4.2.6.8 | Version Number Status Register (VNSR) | 82 |
| 5 | Application Hints | 83 |
| 5.1 | Introduction | 83 |
| 5.1.1 | IOM® and SLD Functions | 83 |
| 5.2 | Configuration of Interfaces | 89 |
| 5.2.1 | PCM Interface Configuration | 89 |
| 5.2.1.1 | PCM Interface Signals | 89 |
| 5.2.1.2 | PCM Interface Registers | 89 |
| 5.2.1.3 | PCM Interface Characteristics | 91 |
| 5.2.2 | Configurable Interface Configuration | 102 |
| 5.2.2.1 | CFI Interface Signals | 102 |
| 5.2.2.2 | CFI Registers | 102 |
| 5.2.2.3 | CFI Characteristics | 104 |
| 5.3 | Data and Control Memories | 130 |
| 5.3.1 | Memory Structure | 130 |
| 5.3.2 | Indirect Register Access | 131 |
| 5.3.3 | Memory Access Commands | 135 |
| 5.3.3.1 | Access to the Data Memory Data Field | 135 |
| 5.3.3.2 | Access to the Data Memory Code (Tristate) Field | 139 |
| 5.3.3.3 | Access to the Control Memory Data Field | 142 |
| 5.3.3.4 | Access to the Control Memory Code Field | 144 |
| 5.4 | Switched Channels | 151 |
| 5.4.1 | CFI - PCM Time Slot Assignment | 152 |
| 5.4.2 | Subchannel Switching | 156 |
| 5.4.3 | Loops | 161 |
| 5.4.3.1 | CFI - CFI Loops | 161 |
| 5.4.3.2 | PCM - PCM Loops | 164 |
| 5.4.4 | Switching Delays | 166 |
| 5.4.4.1 | Internal Procedures at the Serial Interfaces | 167 |
| 5.4.4.2 | How to Determine the Delay | 170 |
| 5.4.4.3 | Example: Switching of Wide Band ISDN Channels with the EPIC® | 172 |
| 5.5 | Preprocessed Channels | 175 |
| 5.5.1 | Initialization of Preprocessed Channels | 176 |
| 5.5.2 | Control/Signaling (CS) Handler | 187 |
| 5.5.2.1 | Registers used in Conjunction with the CS Handler | 188 |
| 5.5.2.2 | Access to Downstream C/I and SIG Channels | 190 |
| 5.5.2.3 | Access to the Upstream C/I and SIG Channels | 191 |
| 5.5.3 | Monitor/Feature Control (MF) Handler | 193 |
| 5.5.3.1 | Registers used in Conjunction with the MF Handler | 195 |
| 5.5.3.2 | Description of the MF Channel Commands | 200 |
| 5.6 | µP Channels | 208 |

| Table of Contents | Page |
|---|-------------|
| 5.7 Synchronous Transfer Utility | .212 |
| 5.7.1 Registers Used in Conjunction with the Synchronous Transfer Utility | .215 |
| 5.8 Supervision Functions | .221 |
| 5.8.1 Hardware Timer | .221 |
| 5.8.2 PCM Input Comparison | .223 |
| 5.8.3 PCM Framing Supervision | .226 |
| 5.8.4 Power and Clock Supply Supervision/Chip Version | .227 |
| 5.9 Applications | .228 |
| 5.9.1 Analog IOM [®] -2 Line Card with SICOFI [®] -4 as Codec/Filter Device | .228 |
| 5.9.2 IOM [®] -2 Trunk Line Applications | .232 |
| 5.9.2.1 PBX With Multiple ISDN Trunk Lines | .233 |
| 5.9.2.2 Small PBX | .238 |
| 5.9.3 Miscellaneous | .240 |
| 5.9.3.1 Interfacing the EPIC [®] to a MUSAC [™] | .240 |
| 5.9.3.2 Space and Time Switch for 16 kbit/s Channels | .242 |
| 5.9.3.3 Interfacing an IOM [®] -2 Terminal Mode Interface to a 2.048 Mbit/s PCM Backplane | .244 |
| 6 Electrical Characteristics | .246 |
| 7 Package Outlines | .257 |
| 8 Appendix | .258 |
| 8.1 Working Sheets | .258 |
| 8.1.1 Register Summary for EPIC [®] Initialization | .258 |
| 8.1.2 Switching of PCM Time Slots to the CFI Interface (data downstream) | .262 |
| 8.1.3 Switching of CFI Time Slots to the PCM Interface (data upstream) | .263 |
| 8.1.4 Preparing EPIC [®] s C/I Channels | .264 |
| 8.1.5 Receiving and Transmitting IOM [®] -2 C/I-Codes | .265 |
| 8.2 Development Tools | .266 |
| 8.2.1 SIPB 5000 Mainboard | .266 |
| 8.2.2 SIPB 5121 IOM [®] -2 Line Card (EPIC [®] /IDEC [®]) | .267 |
| 8.2.3 EPIC [®] Configurator | .268 |
| 9 Lists | .269 |
| 9.1 Glossary | .269 |

IOM[®], IOM[®]-1, IOM[®]-2, SICOFI[®], SICOFI[®]-2, SICOFI[®]-4, SICOFI[®]-4 μ C, SLICOFI[®], ARCOFI[®], ARCOFI[®]-BA, ARCOFI[®]-SP, EPIC[®]-1, EPIC[®]-S, ELIC[®], IPAT[®]-2, ITAC[®], ISAC[®]-S, ISAC[®]-S TE, ISAC[®]-P, ISAC[®]-P TE, IDEC[®], SICAT[®], OCTAT[®]-P, QUAT[®]-S are registered trademarks of Siemens AG.

MUSAC[™]-A, FALC[™]54, IWE[™], SARE[™], UTPT[™], ASM[™], ASP[™] are trademarks of Siemens AG.

Purchase of Siemens I²C components conveys a license under the Philips' I²C patent to use the components in the I²C-system provided the system conforms to the I²C specifications defined by Philips. Copyright Philips 1983.

1 Overview

The PEB 2055 (Extended PCM Interface Controller) is a highly integrated controller circuit optimized for analog and ISDN line card and central switches applications. The EPIC-1 provides the circuitry necessary to manage up to 32 digital (ISDN or proprietary) or 64 analog subscribers.

The EPIC-1 is dedicated to switch PCM data between two serial interfaces, the system interface (PCM interface) and the configurable interface (CFI). The EPIC-1 performs non-blocking time and space switching for up to 128 channels.

Since the system cost of the EPIC-1 is divided by the number of lines it controls, an highly economical implementation of digital or analog subscriber lines can be performed.

The EPIC-S (PEB 2054) is a pin compatible device offering half the switching capacity of the EPIC-1. Therefore the EPIC-S is capable of handling up to 16 ISDN or 32 analog subscribers. It is programmable according to the EPIC-1 with respect of the pins not available.

The EPIC is implemented in a Siemens advanced CMOS-technology and manufactured in a P-LCC-44-1 package.

The EPIC is member of a chip family supporting a highly economical implementation of line cards and subscriber terminals.

Chip Family

Line Cards:

| | | |
|-----------|------------------------------------|------------|
| PEB 2055 | Extended PCM Interface Controller | (EPIC) |
| PEB 20550 | Extended Line Card Controller | (ELIC) |
| PEB 2096 | Octal U_{PN} Transceiver | (OCTAT-P) |
| PEB 2095 | ISDN Burst Transceiver Circuit | (IBC) |
| PEB 2084 | Quadruple S_0 Transceiver | (QUAT-S) |
| PEB 2465 | Quadruple DSP based Codec Filter | (SICOFI-4) |
| PEB 2075 | ISDN D-Channel Exchange Controller | (IDEC) |

Terminals:

| | | |
|-----------------|--|-------------|
| PSB 2196 | Digital Subscriber Access Controller for U_{PN} Interface | (ISAC-P TE) |
| PEB 2081 (V3.2) | S/T-Bus Interface Circuit Extended | (SBCX) |

Extended PCM Interface Controller EPIC®-1, EPIC®-S

PEB 2055
PEF 2055
PEB 2054
PEF 2054

Versions A3 (PEB 2055), V1.0 (PEB 2054)

CMOS

1.1 Features

Switching

- Board Controller for up to
 - 32 ISDN or 64 analog subscribers (PEB 2055)
 - 16 ISDN or 32 analog subscribers (PEB 2054)
- Non-blocking switch for
 - 128 channels (PEB 2055)
 - 64 channels (PEB 2054)
- Switching of 16-, 32-, or 64-kbit/s channels
- Two consecutive 64-kbit/s channels can be switched as a single 128-kbit/s channel
- Freely programmable time slot assignment for all subscribers
- Two serial interfaces (PCM and CFI) programmable over a wide data range (128 - 8192 kbit/s)
- Data rates of PCM and configurable interface independent from each other (data rate adaptation)
- PCM-interface
 - Tristate control signals for external drivers
 - Programmable clock shift
 - Single or double data clock
- Configurable interface
 - Configurable for IOM-, SLD- and PCM-applications
 - High degree of flexibility for datastream adaptation
 - Programmable clockshift
 - Single or double data clock
- Synchronous μ P-access to two selected channels

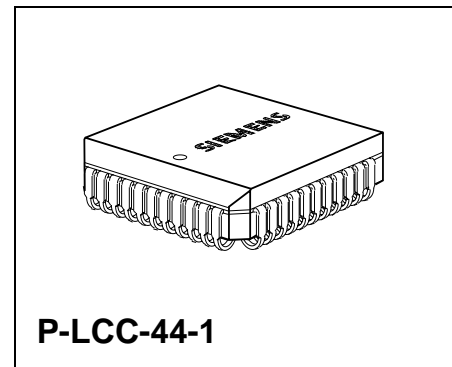

| Type | Ordering Code | Package |
|----------|-------------------|------------|
| PEB 2055 | Q67100-H6035 | P-LCC-44-1 |
| PEF 2055 | Q67100-H6216 | P-LCC-44-1 |
| PEB 2054 | Q67100-H6420 | P-LCC-44-1 |
| PEF 2054 | Q67100-H6534-B701 | P-LCC-44-1 |

Handling of Layer-1 Functions

- Change detection for C/I-channel (IOM-configuration) or feature control (SLD-configuration)
- Double last-look logic for C/I-channel (IOM-2 analog configuration)
- Additional last-look logic for feature control (SLD-configuration)
- Buffered monitor (IOM-configuration) or signaling channel (SLD-configuration)

Bus Interface

- Siemens/Intel or Motorola type μ P-interface
- 8-bit demultiplexed bus interface
- FIFO-access interrupt or DMA controlled

1.2 Pin Configuration (top view)

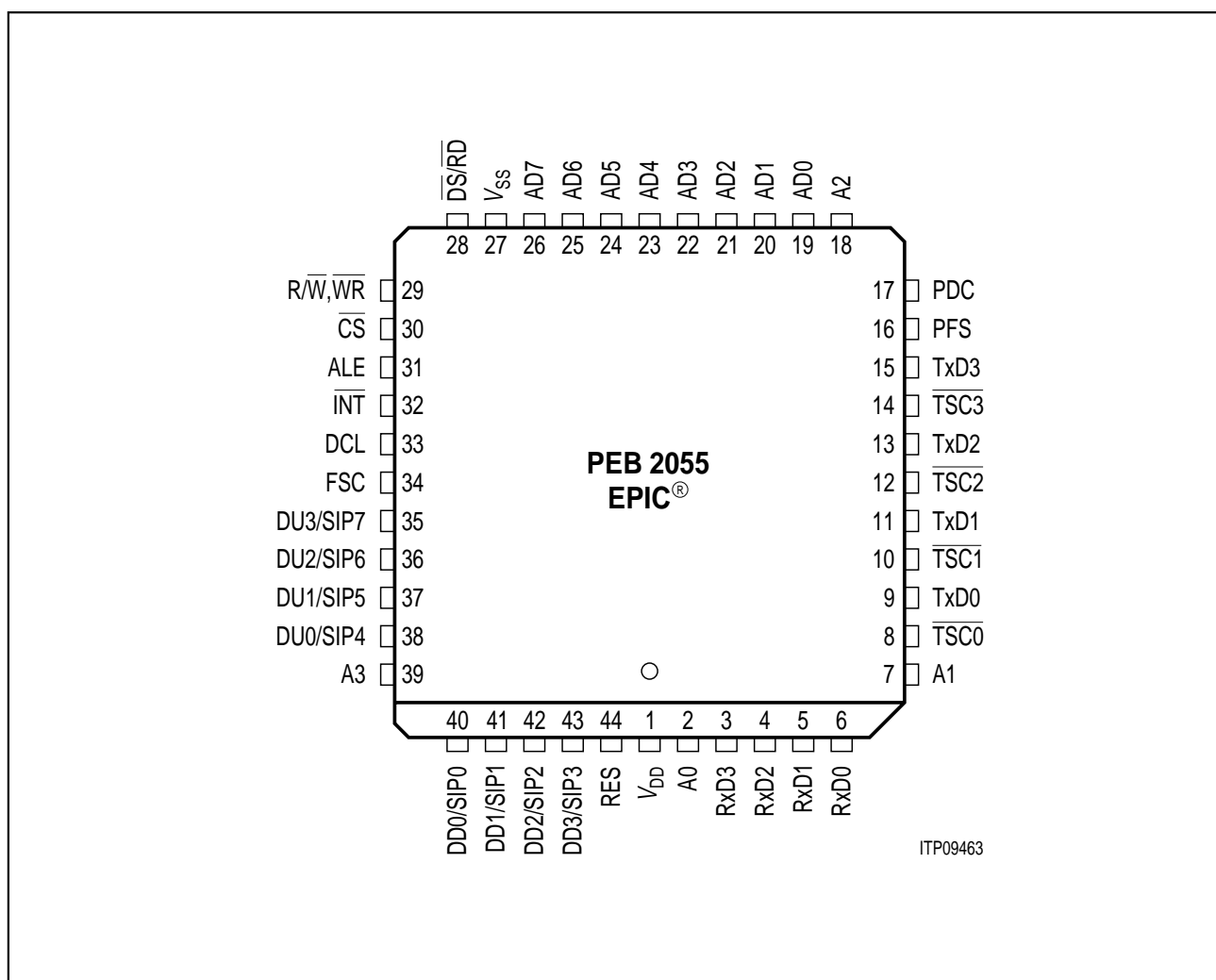
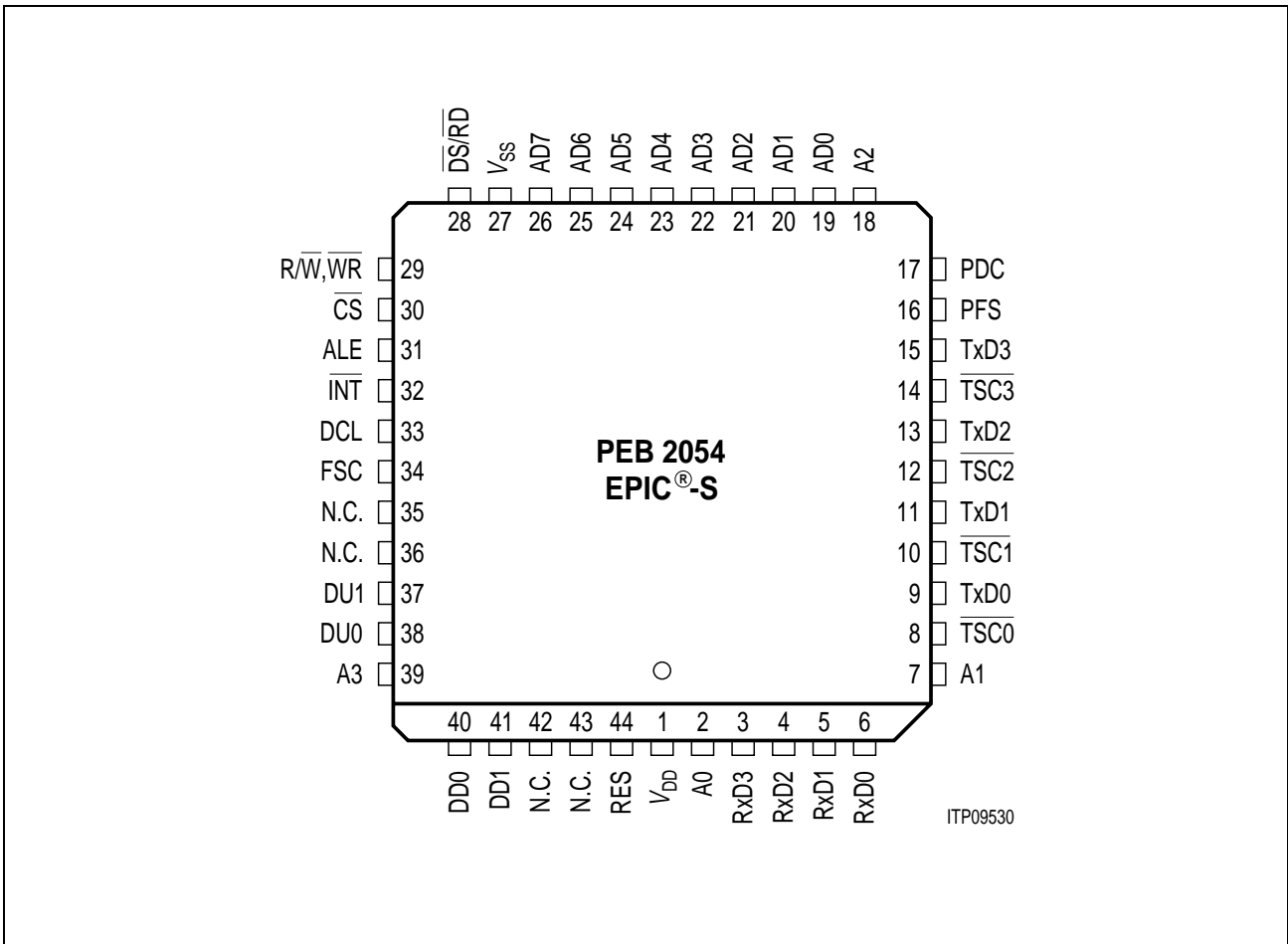

Figure 1
Pin Configuration EPIC®-1



**Figure 2
Pin Configuration EPIC[®]-S**

1.3 Pin Definitions and Functions

| Pin No. | | Symbol | Input (I) Output (O) | Function |
|---------|------|---------------------------------------|-------------------------|--|
| EPIC-S | EPIC | | | |
| 30 | 30 | \overline{CS} | I | Chip Select ; active low. A “low” on this line selects the EPIC for read/write operations. |
| 29 | 29 | \overline{WR} , R/\overline{W} | I | Write , active low, Siemens/Intel bus mode. When “low”, a write operation is indicated. Read/Write , Motorola bus mode. When “high” a valid μ P-access identifies a read operation, when “low” it identifies a write access. |
| 28 | 28 | \overline{RD} , \overline{DS} | I | Read , active low, Siemens/Intel bus mode. When “low” a read operation is indicated. Data Strobe , Motorola bus mode. A rising edge marks the end of a read or write operation. |
| 19 | 19 | AD0, D0 | I/O | Address/Data Bus ; multiplexed bus mode. Transfers addresses from the μ P-system to the EPIC and data between the μ P and the EPIC. Data Bus ; demultiplexed bus mode. Transfers data between the μ P and the EPIC. When driving data the pins have push pull characteristic, otherwise they are in high impedance state. |
| 20 | 20 | AD1, D1 | I/O | |
| 21 | 21 | AD2, D2 | I/O | |
| 22 | 22 | AD3, D3 | I/O | |
| 23 | 23 | AD4, D4 | I/O | |
| 24 | 24 | AD5, D5 | I/O | |
| 25 | 25 | AD6, D6 | I/O | |
| 26 | 26 | AD7, D7 | I/O | |
| 31 | 31 | ALE | I | Address Latch Enable ALE controls the on chip address latch in multiplexed bus mode. While ALE is “high”, the latch is transparent. The falling edge latches the current address. During the first read/write access following reset ALE is evaluated to select the bus mode. |
| 32 | 32 | \overline{INT} | O (OD) | Interrupt Request , active low. This signal is activated when the EPIC requests an interrupt. Due to the open drain (OD) characteristic of \overline{INT} multiple interrupt sources can be connected together. |
| 44 | 44 | RES | I | Reset A “high” forces the EPIC into reset state. |
| 16 | 16 | PFS | I | PCM Interface Frames Synchronization |

1.3 Pin Definitions and Functions (cont'd)

| Pin No. | | Symbol | Input (I) Output (O) | Function |
|---------|------|--------------------------|-------------------------|--|
| EPIC-S | EPIC | | | |
| 17 | 17 | PDC | I | PCM Interface Data Clock Single or double data rate. |
| 6 | 6 | RxD0 | I | Receive PCM Interface Data Time-slot oriented data is received on this pins and forwarded into the downstream data memory of the EPIC. |
| 5 | 5 | RxD1 | I | |
| 4 | 4 | RxD2 | I | |
| 3 | 3 | RxD3 | I | |
| 9 | 9 | TxD0 | O | Transmit PCM Interface Data Time slot oriented data is shifted out of the EPIC's upstream data memory on this lines. For time-slots which are flagged in the tristate data memory or when bit OMDR:PSB is reset the pins are set to high impedance state. |
| 11 | 11 | TxD1 | O | |
| 13 | 13 | TxD2 | O | |
| 15 | 15 | TxD3 | O | |
| 8 | 8 | $\overline{\text{TSC0}}$ | O | Tristate Control Supplies a control signal for an external driver. These lines are "low" when the corresponding TxD outputs are valid. During reset these lines are "high". |
| 10 | 10 | $\overline{\text{TSC1}}$ | O | |
| 12 | 12 | $\overline{\text{TSC2}}$ | O | |
| 14 | 14 | $\overline{\text{TSC3}}$ | O | |
| 34 | 34 | FSC | I/O | Frame Synchronization Input or output in IOM configuration. Direction indication signal in SLD mode. |
| 33 | 33 | DCL | I/O | Data Clock Input or output in IOM, slave clock in SLD configuration. In IOM configuration single or double data rate, single data rate in SLD mode. |
| 38 | 38 | DU0/SIP4 | I/O (OD) | Data Upstream Input; IOM or PCM configuration. Serial Interface Port, SLD configuration. Depending on the bit OMDR:COS these lines have push pull or open drain characteristic. For unassigned channels or when bit OMDR:CSB is reset the pins are in the state high impedance. * Note: EPIC-1 only |
| 37 | 37 | DU1/SIP5 | I/O (OD) | |
| - | 36 * | DU2/SIP6 | I/O (OD) | |
| - | 35 * | DU3/SIP7 | I/O (OD) | |

1.3 Pin Definitions and Functions (cont'd)

| Pin No. | | Symbol | Input (I) Output (O) | Function |
|---------|------|----------|-------------------------|---|
| EPIC-S | EPIC | | | |
| 40 | 40 | DD0/SIP0 | O/IO (OD) | Data Downstream Output, IOM or PCM configuration. Serial Interface Port, SLD configuration. Depending on the bit OMDR:COS these lines have push pull or open drain characteristic. For unassigned channels or when bit OMDR:CSB is reset the pins are in the high impedance state. * Note: EPIC-1 only |
| 41 | 41 | DD1/SIP1 | O/IO (OD) | |
| - | 42 * | DD2/SIP2 | O/IO (OD) | |
| - | 43 * | DD3/SIP3 | O/IO (OD) | |
| 2 | 2 | A0 | I/O | Address bus in the demultiplexed μP interface mode. |
| 7 | 7 | A1 | | |
| 18 | 18 | A2 | | |
| 39 | 39 | A3 | | |
| 1 | 1 | V_{DD} | I | Supply voltage: 5 V \pm 5% |
| 27 | 27 | V_{SS} | I | Ground: 0 V |

1.4 Logic Symbols

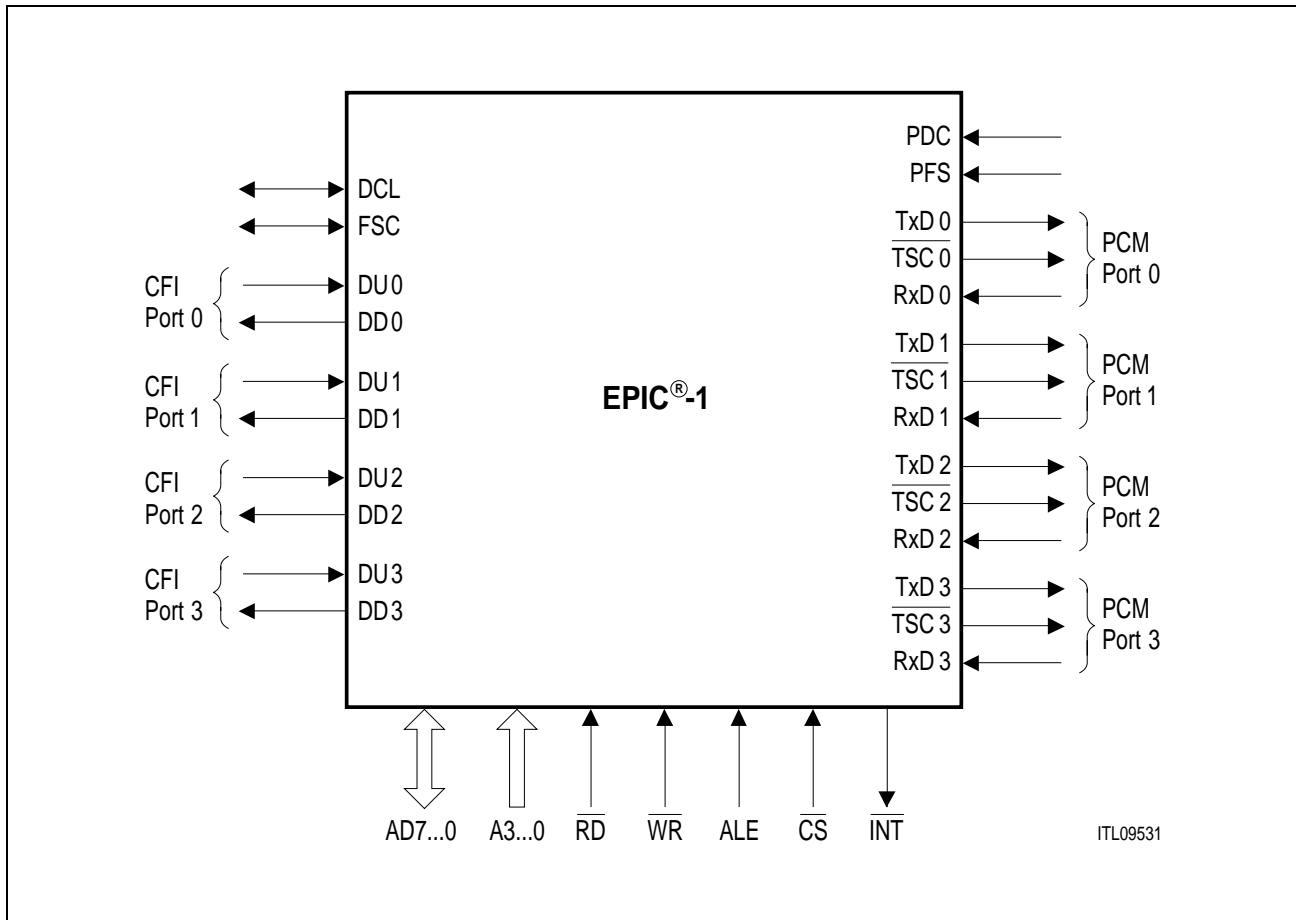

Figure 3
Logic Symbol of the EPIC[®]-1

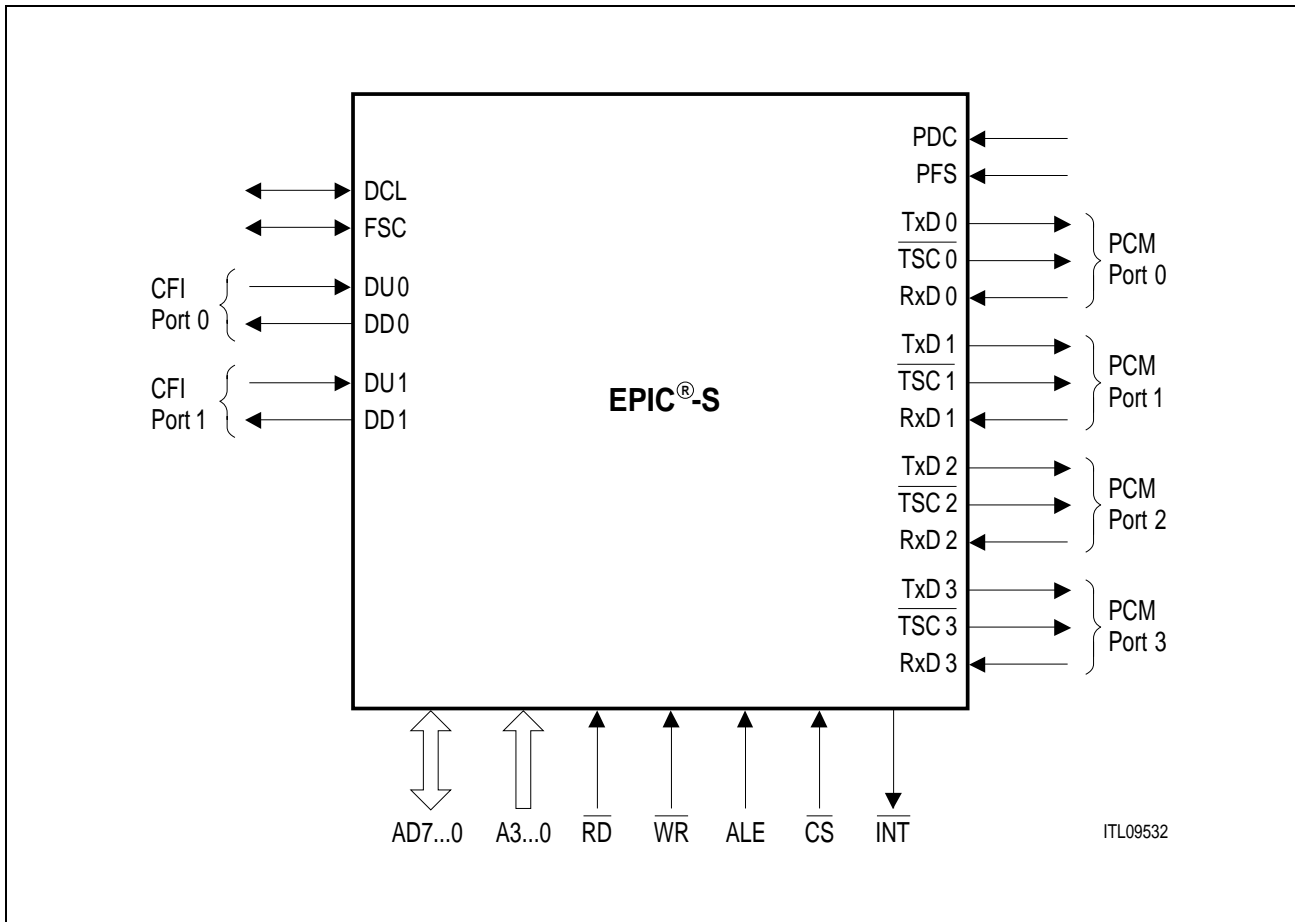
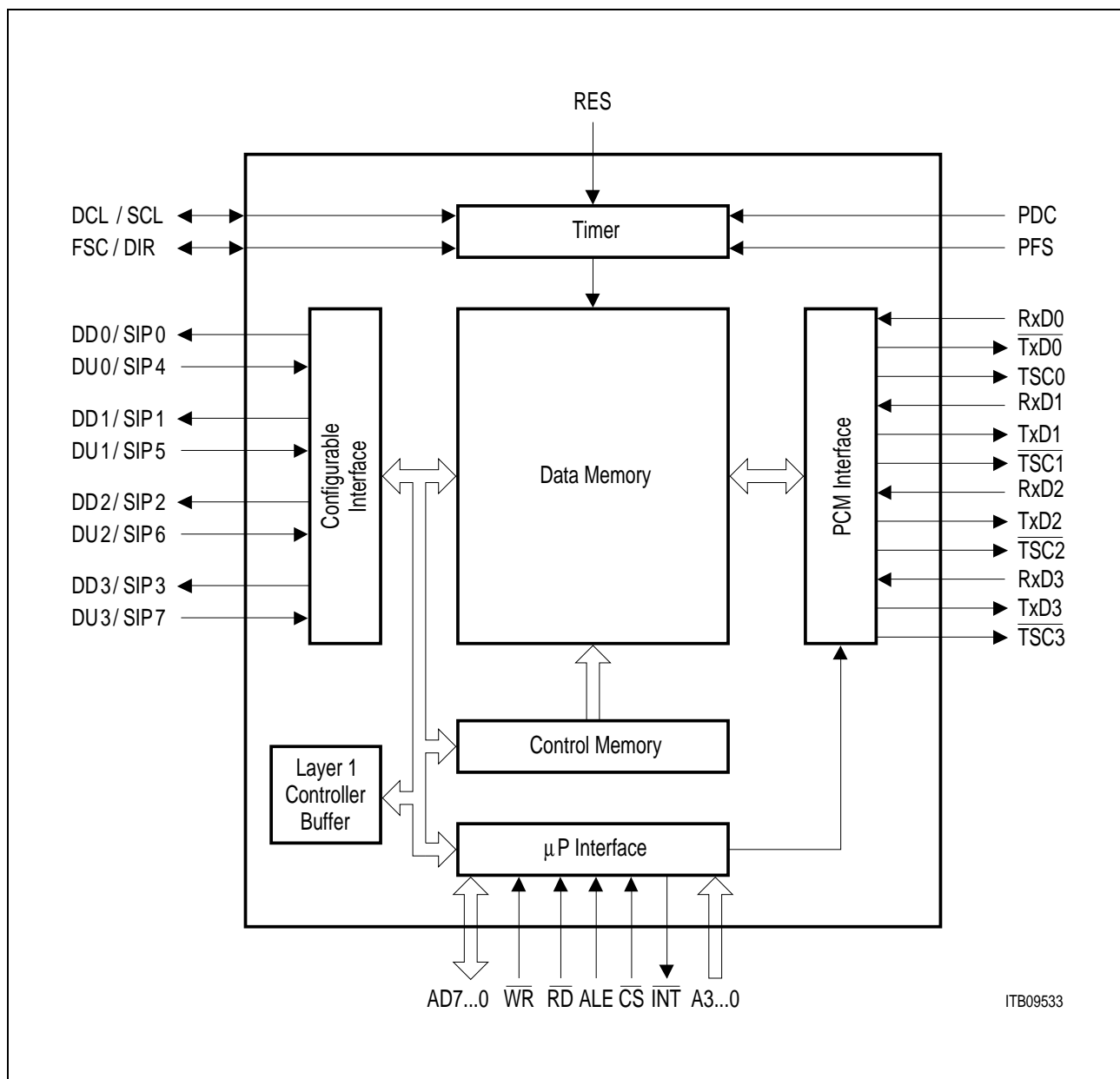

Figure 4
Logic Symbol of the EPIC[®]-S

1.5 Functional Block Diagram



ITB09533

Figure 5
Functional Block Diagram EPIC®

1.6 Using the EPIC-S

The EPIC-S is based on the same technology as the EPIC-1 aside from only providing CFI port 0 and CFI port 1. Therefore this User's Manual applies to both, the EPIC-S and the EPIC-1.

When using the EPIC-S the user has to be aware not to program connections that would imply the not supported CFI ports.

The following points require specific attention:

1. During power up the EPIC-S must be supplied with an external Hardware Reset.
2. Register bit OMDR:CSB may be programmed to high (switch off standby of CFI interface) only after a Control Memory reset procedure with MACR:CMC3..0 = 0_H.
3. The pins not available with respect to the EPIC-1 (PEB 2055) must not be programmed as outputs.

1.7 System Integration and Application

The main application fields of the EPIC are:

- Digital line cards with different architectures,
- Central control units of key systems,
- Analog line cards,
- Concentrators.

1.7.1 Digital Line Card

1.7.1.1 Switching, Layer-1 Control

The EPIC provides a switching capability for up to 32 digital subscribers between the PCM system highway and the IOM-2 interface (64 B-channels). Typically it switches 64-kbit/s channels between the PCM and the IOM-interfaces. Moreover it is able to handle also 16-, 32- and 128-kbit/s channels.

The signaling handler supports the command/indication (C/I) channel which is used to exchange predefined layer-1 information with the transceiver device.

A monitor handler supports the handshake protocol defined on the IOM-monitor channel. It allows programming of layer-1 devices which do not have a dedicated μ P interface.

The EPIC can be operated in tandem, i.e. one device is active, another one is a backup device. The backup device can instantaneously take over from the active device when the active device fails. Due to this tandem operation capability and the high number of ISDN subscribers which can be connected to one EPIC, the use of single line cards is feasible.

Several line card architectures are possible.

1.7.1.2 Decentralized D-Channel Handling

In completely decentral D-channel processing architectures (see **figure 6**), the processing capacity of the line card is usually designed to avoid blocking situations even under maximum conceivable D-channel traffic conditions. In such an architecture the EPIC switches the B-channels and performs C/I and monitor channel control.

The IDECs handle the layer 2 functions for signaling and data packets in the D-channel. They transfer the extracted data via the μ P and an HDLC controller, e.g. the HSCX (High Level Serial Controller Extended SAB 82525) to the system. One of the channels of the HSCX may access either a time slot of programmable bandwidth on one of the system highways or a separate signalling highway.

In both cases the highway capacity used for packet traffic can be shared among several line cards due to the statistical multiplexing capabilities of the HSCX.

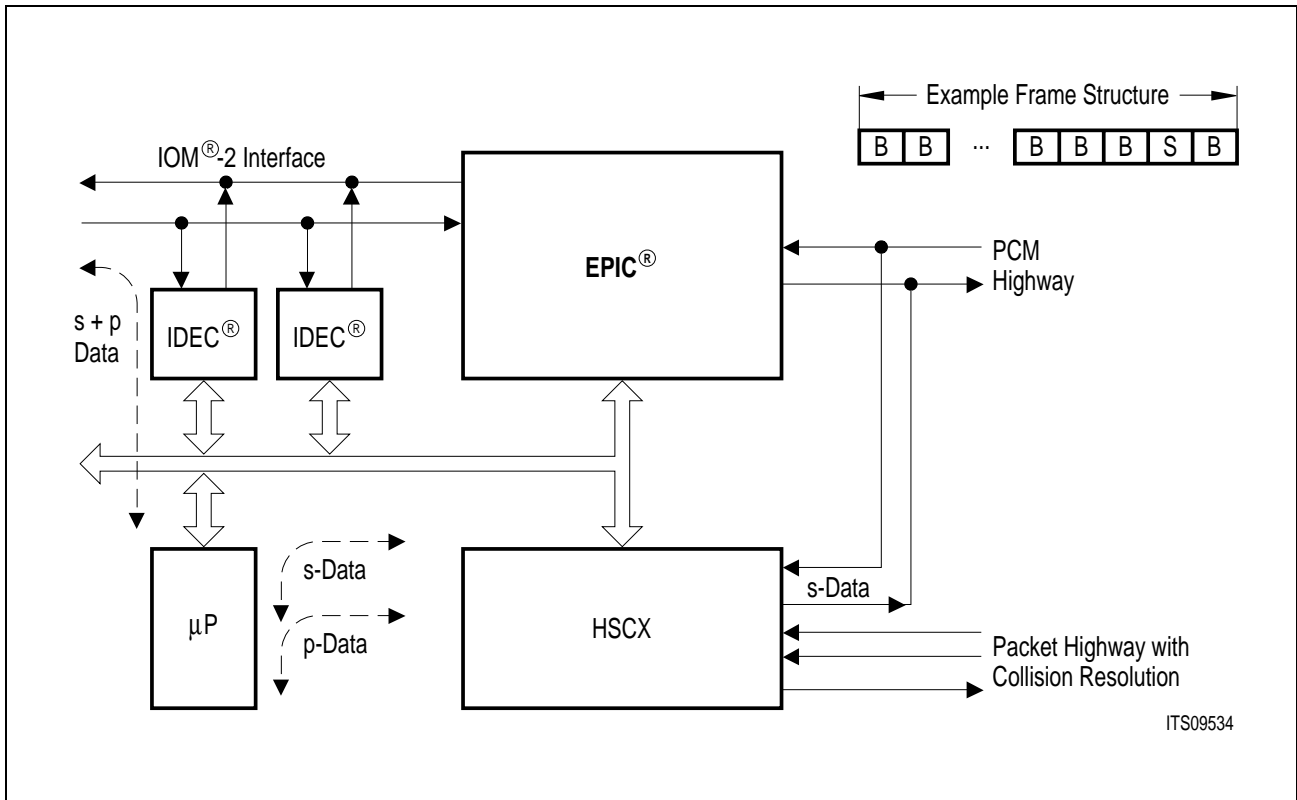

Figure 6
Line Card Architecture for Completely Decentral D-Channel Processing

1.7.1.3 Central D-Channel Processing

In this application the EPIC not only switches the B-channels and performs the C/I- and monitor channel control function, but switches also the D-channel data onto the system highway. In upstream direction the EPIC can combine up to four 16-kbit/s D-channels into one 64-kbit/s channel. In downstream direction it provides the capability to distribute one 64-kbit/s channel to four 16-kbit/s channels.

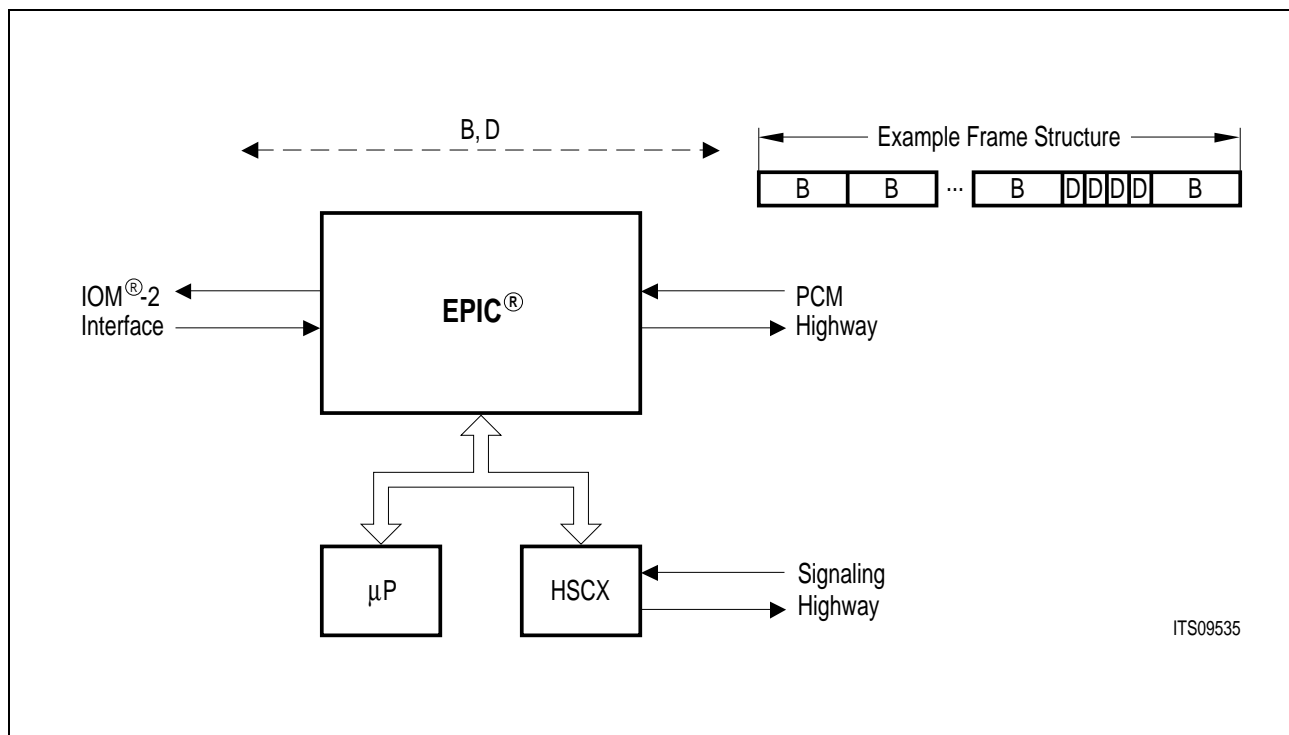

Figure 7
Digital Line Card Architecture with a Completely Central D-Channel Handling

1.7.1.4 Mixed D-Channel Processing, Signaling Decentralized, Packet Data Centralized

Another possibility is a mixed architecture with centralized packet data and decentralized signaling handling. This is a very flexible architecture which reduces the dynamic load of central processing units by evaluating the signaling information on the line card, but does not require resources for packet data handling. Any increase of packet data traffic does not necessitate a change in the line card architecture, the central packet handling unit can be expanded.

In this application IDECs are employed to handle the data on the D-channel. The IDECs separate signaling information from data packets. The signaling messages are transferred to the μP , which in turn hands them over to the group controller using the HSCX.

The packet data is processed differently. Together with the collision resolution information it is transferred to one IOM-2 port of the EPIC. The EPIC switches the channels to the PCM-highway, optionally combining four D-channels to one 64-kbit/s channel. In this configuration one IOM-2 interface is occupied by IDECs, reducing the total switching capability of the EPIC-1 to 24 ISDN-subscribers.

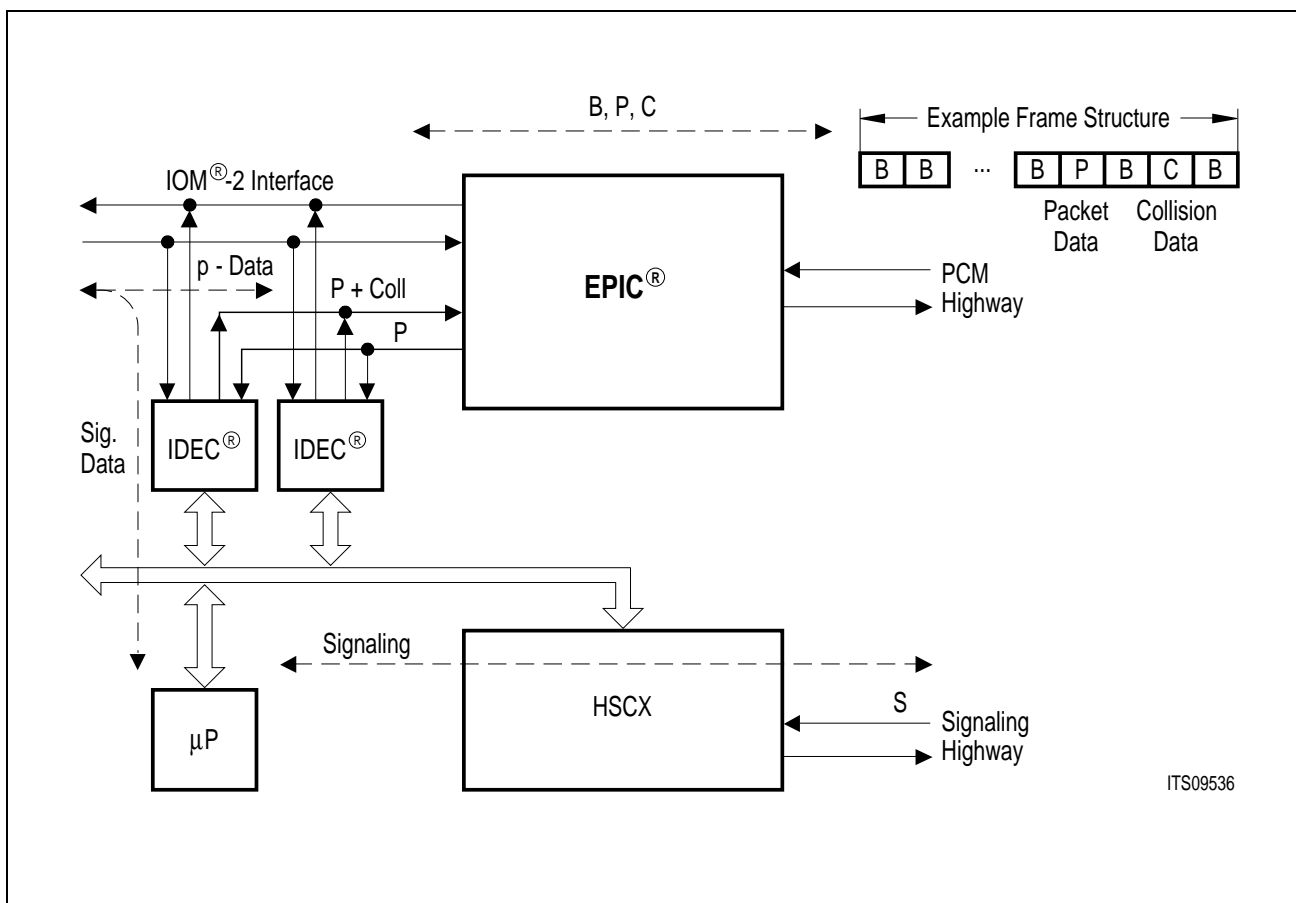

Figure 8
Line Card Architecture for Mixed D-Channel Processing

Alternatively, the packet and collision data can be directly exchanged between the IDECs and the PCM-highway. Thus, the full 32 subscriber switching capability of the EPIC is retained.

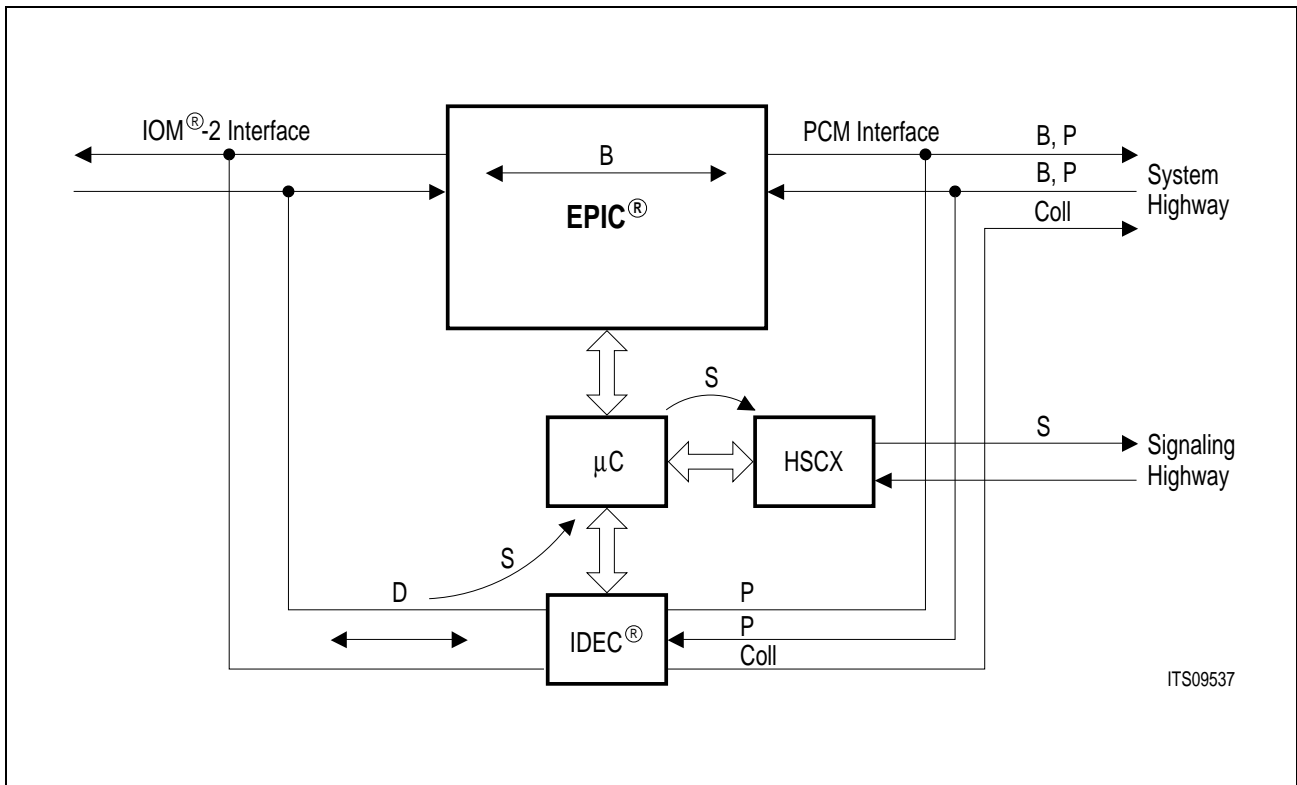

Figure 9
Line Card Architecture for Mixed D-Channel Processing

1.7.2 Analog Line Card

Together with the highly flexible Siemens codec filter circuits SLICOFI, SICOFI, SICOFI-2 or SICOFI-4 the EPIC constitutes an optimized analog subscriber board architecture.

The EPIC-1 handles the signalling and voice data for up to 64 subscriber channels with 64 kbit/s. The HSCX establishes the link to the group controller board.

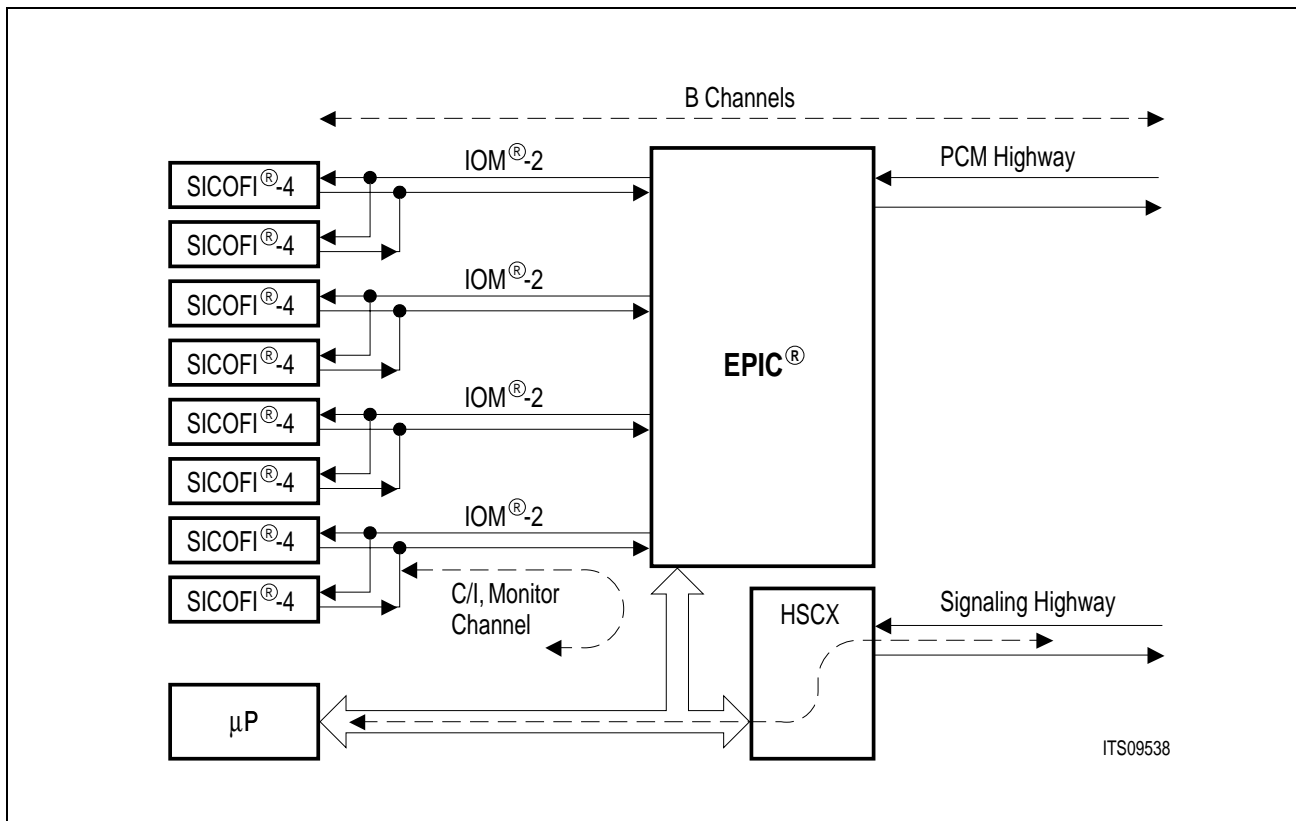

Figure 10
Line Card Architecture for Analog Subscribers

1.7.3 Packet Handlers

The EPIC is an important building block for networks based on either central, decentral or mixed signaling and packet data handling architectures. Its flexibility allows for the modification of the packet handling architecture according to the changing needs.

Thus it may be useful to add central packet handling groups to a network originally based on decentral signaling and packet handling. This may be the case if growing data packet traffic exceeds the initial capacity of the network. The result is a mixed architecture.

On the other hand, increasing packet handling demand on a few dedicated subscriber lines calls for solutions which back up the capacity at these few decentral line cards.

In both of these cases and several other applications, the EPIC is a powerful device for solving the problem of packet handling. In most applications it is used together with the IDEC (ISDN D channel Exchange Controller).

Decentralized and mixed packet handling has already been covered in the line card chapter. In the following, the centralized signaling/packet handlers built up with the EPIC will be described.

Central packet handling is used if many subscribers with a generally low demand for packet switching are to be connected to a system. Concentrating the packet servers for multiple users eliminates the need to provide a packet server channel for every user. The overall number of packet server channels can thus be reduced.

In such a central packet handling group, the EPIC performs the switching and concentrator function. It connects a variable number of PCM highways to the packet handler internal highway. HDLC controllers are also connected to this internal highway as illustrated in **figure 11**.

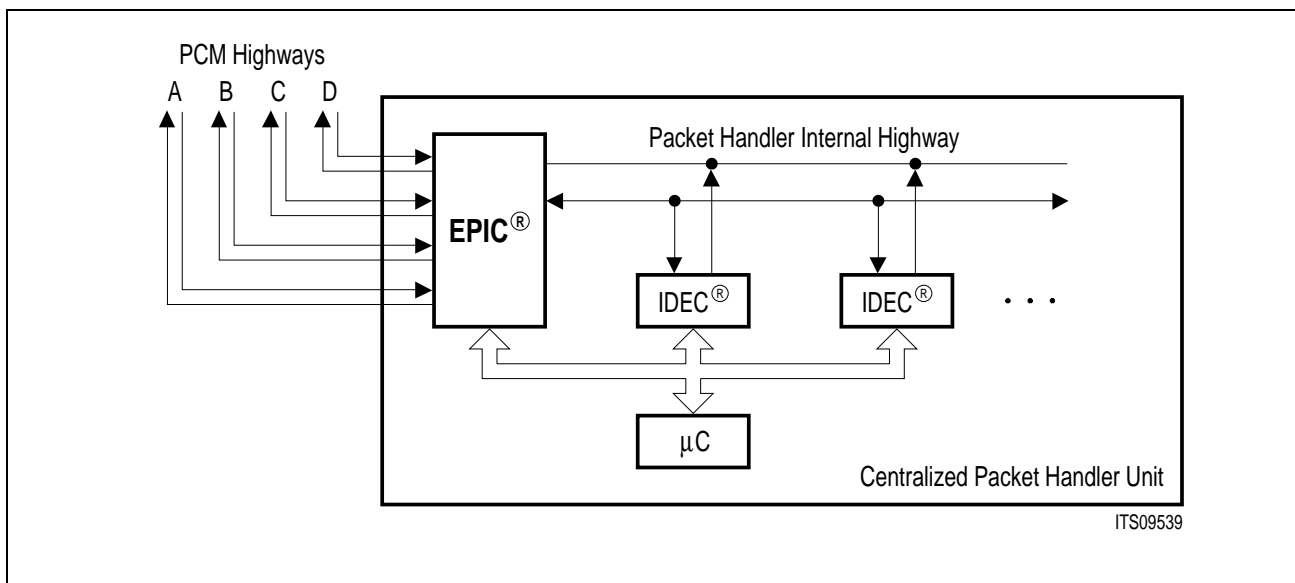

Figure 11
Centralized Packet Handler with a Single Internal Highway Connected to 4 PCM Highways

This figure shows one EPIC connecting four PCM highways to one packet handler internal highway. These highways are accessed by the IDECs, which are 4 channel HDLC controller and handle the packets. If more than four PCM highways shall be connected to the centralized packet handler, further EPICs are necessary. Such a configuration is shown in **figure 12**, where 8 highways are switched to one packet handler internal highway. In this case the two EPICs are connected in parallel at the packet handlers internal side.

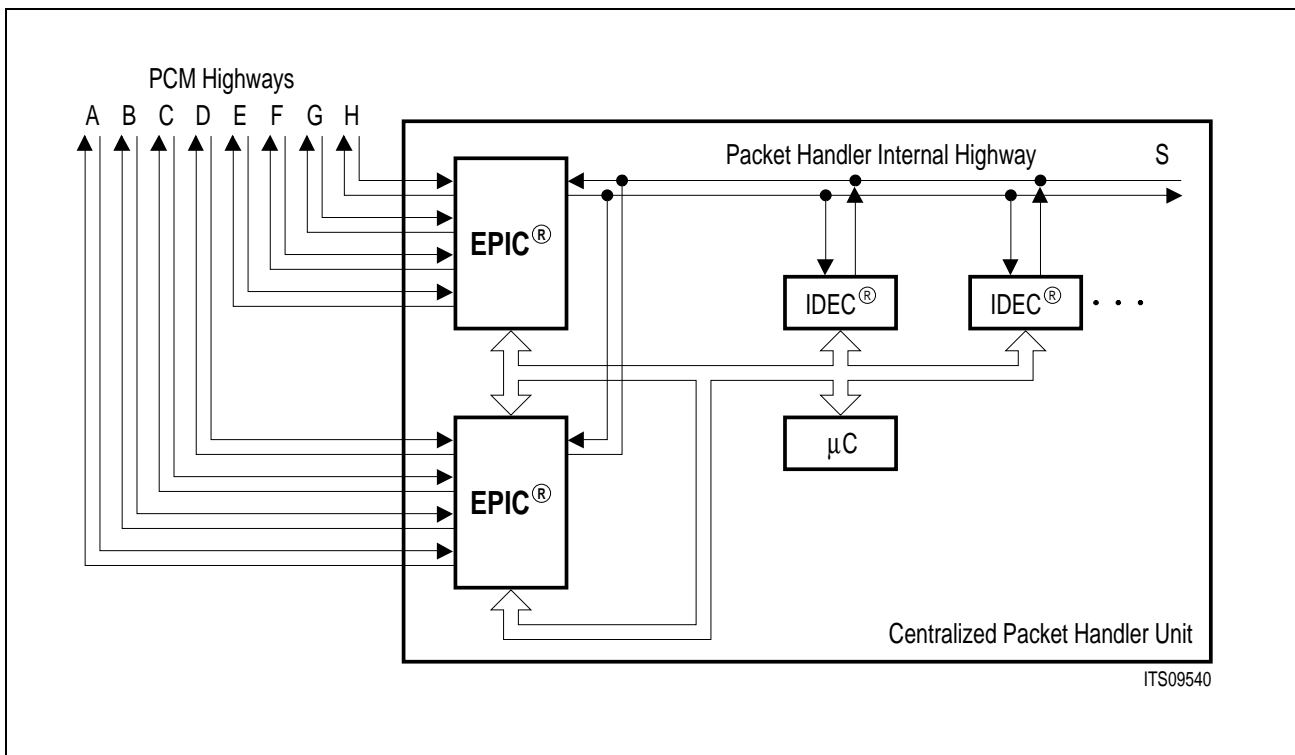

Figure 12
Centralized Packet Handler with One Internal Highway Connected to 8 PCM Highways

The data rate of the packet handler internal highway can be up to 4.096 Mbit/s. If this capacity is not sufficient, other packet handler internal highways may be added as depicted in **figure 13**.

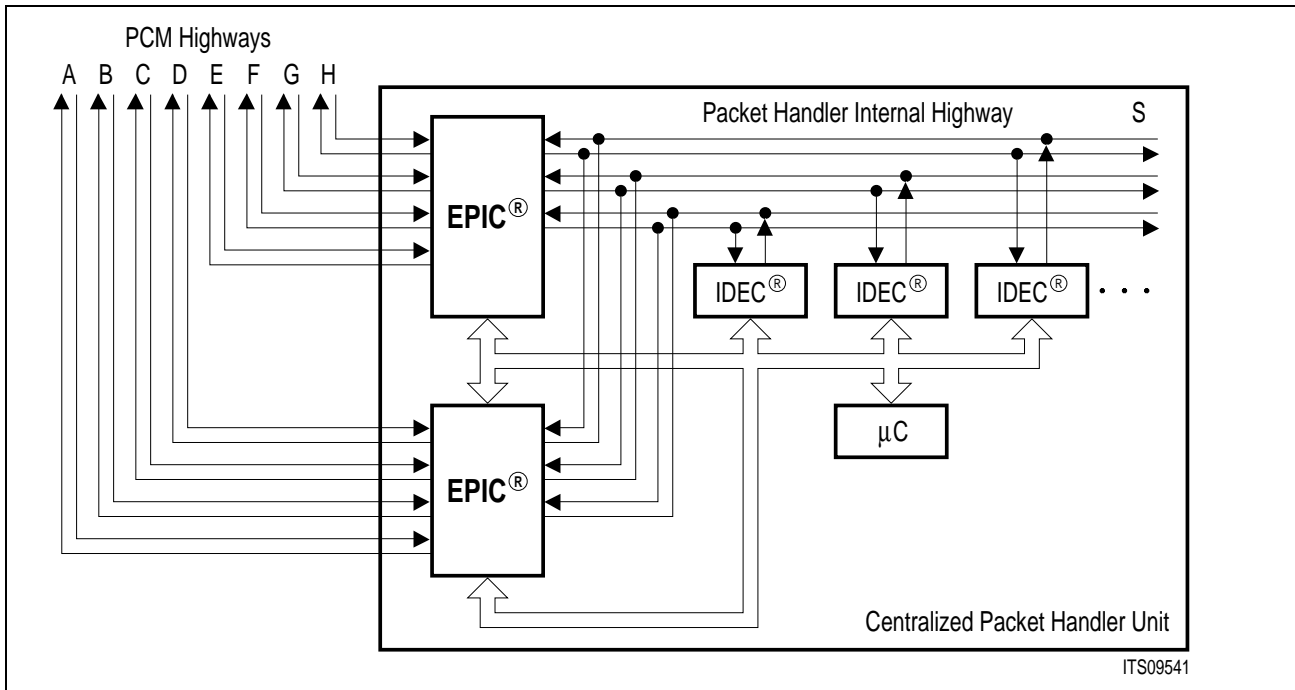

Figure 13
Centralized Packet Handler with 3 Internal Highways

In some applications an additional collision resolution signal is required for the HDLC controllers. This information can be demultiplexed from the PCM highways to a third line for each packet handler internal highway (refer to **figure 14**).

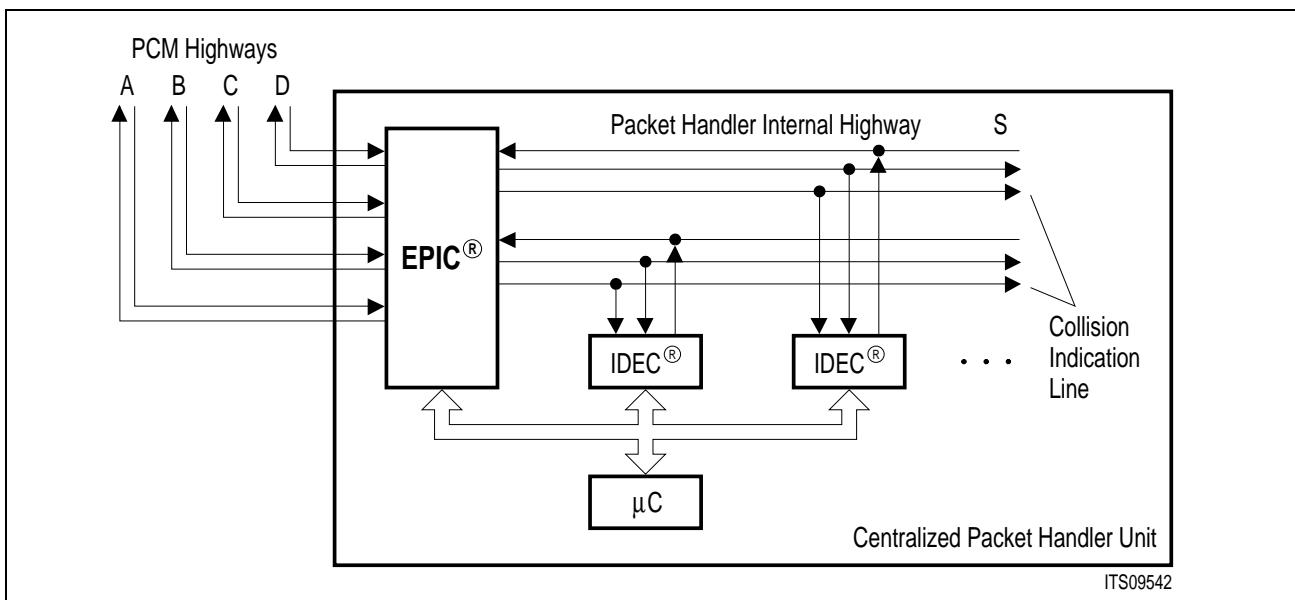

Figure 14
Centralized Packet Handler with Internal Collision Line

The applications apply equally to centralized signaling as well as to data packet handlers.

2 Functional Description

In the following chapters the functions of the PEB 2055 will be covered in more detail.

2.1 Bus Interface

All registers and the FIFOs of the EPIC are accessible via the flexible bus interface supporting Siemens / Intel and Motorola type microprocessors. Depending on the register functionality a read, write or read/write access is possible.

The bus interface consists of the following elements

- Data bus, 8-bit wide, D7 .. 0
- Address bus, 4-bit wide, A3 .. 0
- Chip select, \overline{CS}
- Address latch enable, ALE
- Two read/write control lines: \overline{RD} and \overline{WR} (Intel mode) or \overline{DS} and R/\overline{W} (Motorola mode)
- Interrupt, \overline{INT}
- Reset, RES

The ALE line is used to control the bus structure and interface type.

**Table 1
Selectable Bus Configurations**

| ALE | Interface | Bus Structure | Pin 28 | Pin 29 |
|-------------------|------------------|----------------------|-----------------|------------------|
| Fixed to V_{DD} | Motorola | demultiplexed | \overline{DS} | R/\overline{W} |
| Fixed to ground | Siemens / Intel | demultiplexed | \overline{RD} | \overline{WR} |
| Switching | Siemens / Intel | multiplexed | \overline{RD} | \overline{WR} |

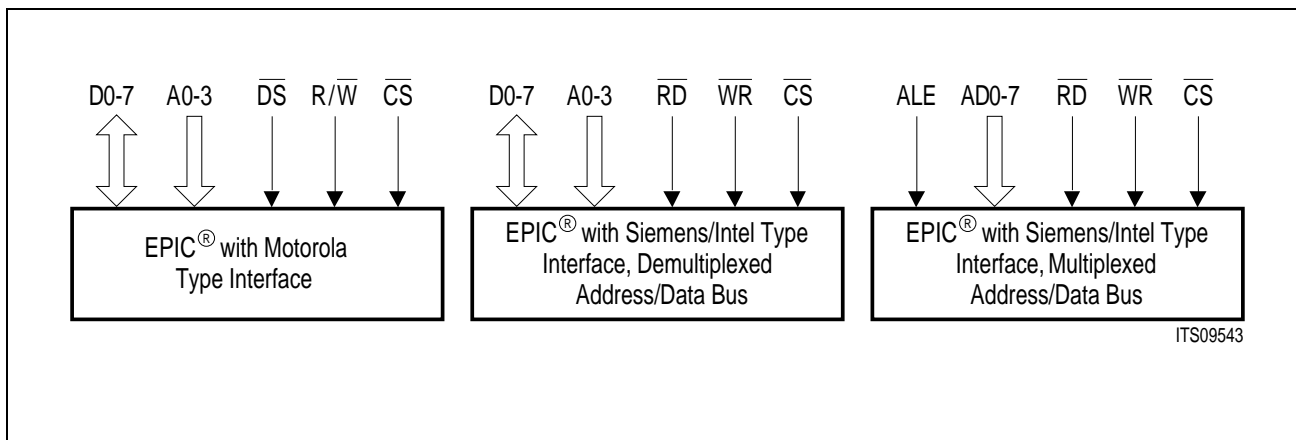

**Figure 15
Selectable Bus Interface Structures**

Functional Description

In order to simplify the use of 8- and 16-bit Siemens / Intel type CPUs, different register addresses are defined in multiplexed and demultiplexed bus mode (see **chapter 4.1**). In the multiplexed mode even addresses are used (AD0 always 0).

For a demultiplexed μ P interface mode the OMDR:RBS bit is needed in addition to the address lines A3 .. A0. With OMDR:RBS (register bank selection) one of two register banks is selected.

RBS = "1" selects a set of registers used for device initialization (e.g. CFI and PCM interface initialization).

RBS = "0" switches to a group of registers necessary during operation (e.g. connection programming).

The OMDR register containing the RBS bit can be accessed with either value of RBS.

Interrupts

An interrupt of the EPIC is indicated by activating the $\overline{\text{INT}}$ line. The detailed cause of the request can be determined by reading the ISTA register.

The $\overline{\text{INT}}$ output is level active. It remains active until all interrupt sources have been serviced. If a new status bit is set while an interrupt is being serviced, the $\overline{\text{INT}}$ remains active. However, for the duration of a write access to the MASK-register the $\overline{\text{INT}}$ line is deactivated. When using an edge-triggered interrupt controller, it is thus recommended to rewrite the MASK register at the end of any interrupt service routine.

Every interrupt source can be selectively masked by setting the respective bit of the MASK register. Such masked interrupts will not be indicated in the ISTA register, nor will they activate the $\overline{\text{INT}}$ line.

2.2 PCM Interface

The PCM interface formats the data transmitted or received at the PCM highways. It can be configured to provide one (max. 8.192 Mbit/s), two (max. 4.096 Mbit/s) or four (max. 2.048 Mbit/s) PCM-ports, consisting each of a data receive ($\overline{\text{RxD}}$), a data transmit ($\overline{\text{TxD}}$) and an output tristate indication line ($\overline{\text{TSC}}$).

The PCM interface is supplied with a frame signal (PFS) and a PCM clock (PDC). To properly clock the PCM interface, a PDC signal with a frequency equal or twice the data rate has to be applied to the EPIC.

Port configuration, data rates, clock shift and sampling conditions are programmable.

2.3 Configurable Interface

In order to optimize the on-board interchip communication, a very flexible serial interface is available. It formats the data transmitted or received at the DDn-, DUn- or SIPn-lines. Although it is typically used in IOM-2 or SLD-configuration to connect layer-1 devices, application specific frame structures can be defined (e.g. to interface ADPCM-converters or maintenance blocks).

Figure 16 shows the IOM-2 Interface structure in Line Card Mode:

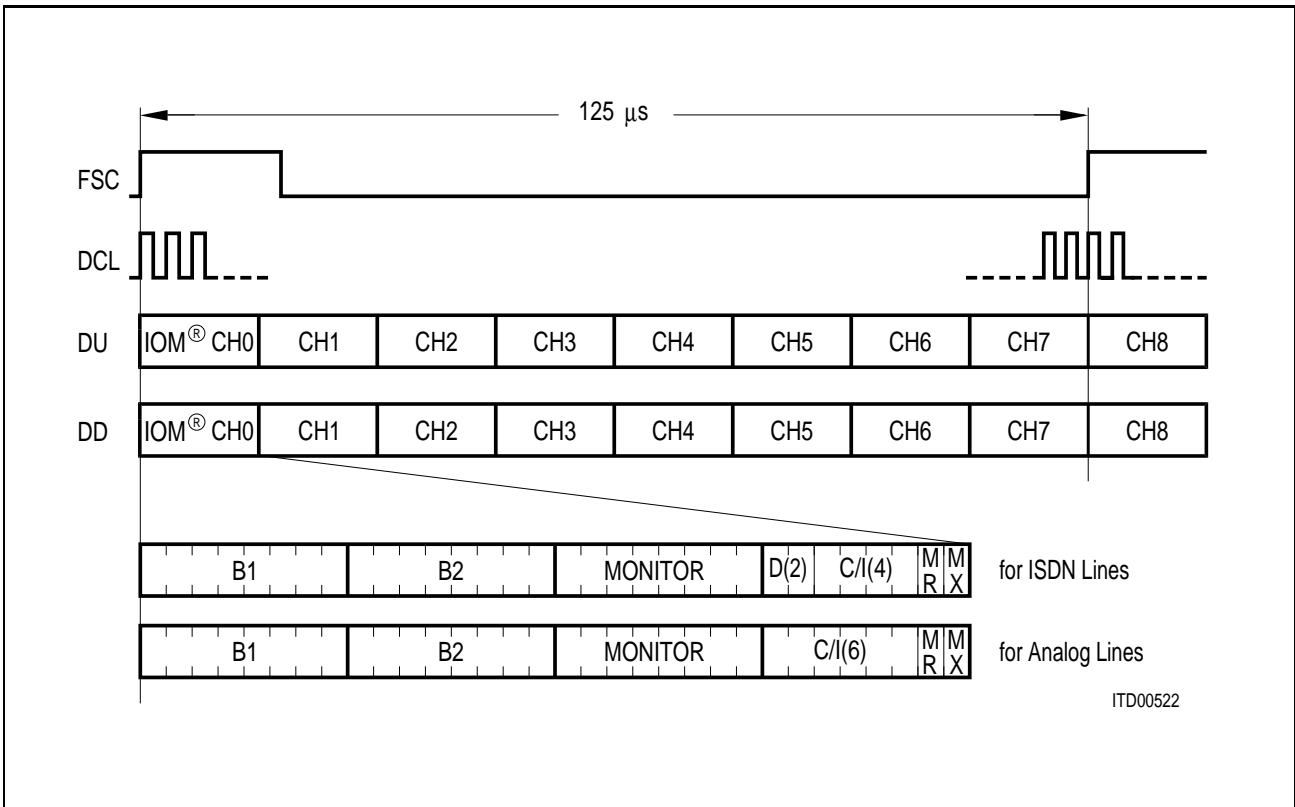

Figure 16
IOM[®]-2 Frame Structure with 2.048 Mbit/s Data Rate

2.4 Memory Structure and Switching

The memory block of the EPIC performs the switching functionality. It consists of four sub blocks:

- Upstream data memory
- Downstream data memory
- Upstream control memory
- Downstream control memory.

The PCM-interface reads periodically from the upstream (writes periodically to the downstream) data memory (cyclical access), see **figure 17**.

Functional Description

The CFI reads periodically the control memory and uses the extracted values as pointers to write to the upstream (read from the downstream) data memory (random access). In the case of C/I- or signaling channel applications the corresponding data is stored in the control memory. In order to select the application of choice, the control memory provides a code portion.

The control memory is accessible via the μ P-interface. In order to establish a connection between CFI time slot A and PCM-interface time slot B, the B-pointer has to be loaded into the control memory location A.

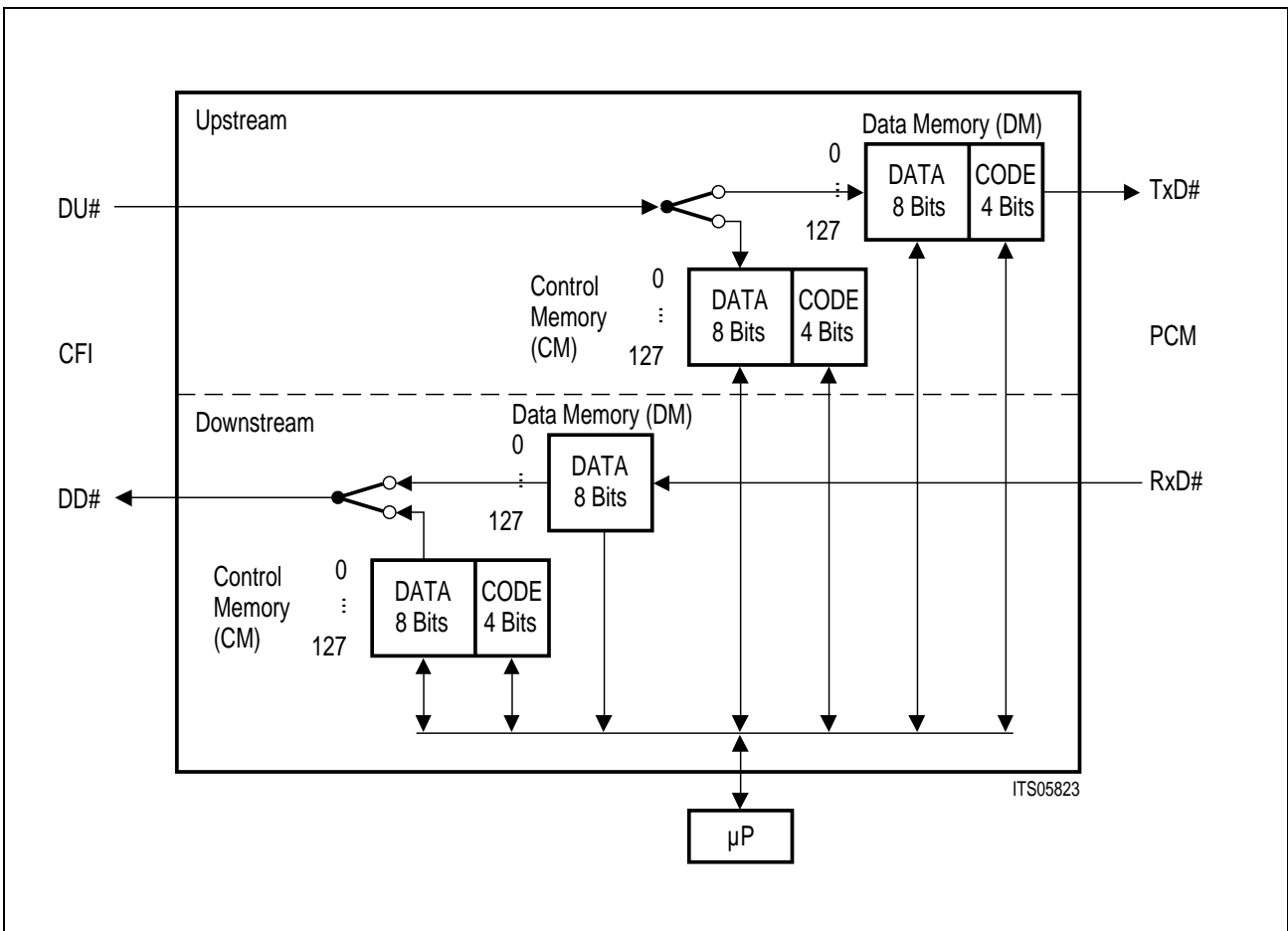

Figure 17
EPIC®-1 Memory Structure

2.5 Pre-processed Channels, Layer-1 Support

The EPIC supports the monitor/feature control and control/signalling channels according to SLD or IOM-2 interface protocol.

The monitor handler controls the data flow on the monitor/feature control channel either with or without an active handshake protocol. To reduce the dynamic load of the CPU a 16-byte transmit/receive FIFO is provided.

The signaling handler supports different schemes (D-channel + C/I-channel, 6-bit signaling, 8-bit signaling).

In downstream direction the relevant content of the control memory is transmitted in the appropriate CFI time slot. In the case of centralized ISDN D-channel handling, a 16-kbit/s D-channel received at the PCM-interface is included.

In upstream direction the signaling handler monitors the received data. Upon a change it generates an interrupt, the channel address is stored in the 9-byte deep C/I FIFO and the actual value is stored in the control memory. In 6-bit and 8-bit signaling schemes a double last look check is provided.

2.6 Special Functions

- Synchronous transfer.
This utility allows the synchronous μ P-access to two independent channels on the PCM or CFI interface. Interrupts are generated to indicate the appropriate access windows.
- 7-bit hardware timer.
The timer can be used to cyclically interrupt the CPU, to determine the double last look period, to generate a proper CFI-multiframe synchronization signal or to generate a defined RESIN pulse width.
- Frame length checking.
The PFS period is internally checked against the programmed frame length.
- Alternative input functions.
In PCM mode 1 and 2, the unused ports can be used for redundancy purposes. In these modes, for every active input port a second input port exists which can be connected to a redundant PCM line. Additionally the two lines are checked for mismatches.

3 Operational Description

The EPIC, designed as a flexible line-card controller, has the following main applications:

- Digital line cards, with the CFI typically configured as IOM-2, IOM-1 (MUX) or SLD.
- Analog line cards, with the CFI typically configured as IOM-2 or SLD.
- Key systems, where the EPIC's ability to mix CFI configurations is utilized.

To operate the EPIC the user must be familiar with the device's microprocessor interface, interrupt structure and reset logic.

3.1 Microprocessor Interface Operation

The EPIC is programmed via an 8-bit parallel interface that can be selected to be

- (1) Motorola type, with control signals \overline{DS} , R/\overline{W} and \overline{CS} .
- (2) Siemens / Intel non-multiplexed bus type, with control signals \overline{WR} , \overline{RD} and \overline{CS} .
- (3) Siemens / Intel multiplexed address/data bus type, with control signals ALE, \overline{WR} , \overline{RD} , and \overline{CS} .

The selection is performed via pin ALE as follows:

- ALE tied to V_{DD} \Rightarrow (1)
- ALE tied to V_{SS} \Rightarrow (2)
- Edge on ALE \Rightarrow (3)

The occurrence of an edge on ALE, either positive or negative, at any time during the operation immediately selects interface type (3). A return to one of the other interface types is only possible by issuing a hardware reset.

In order to simplify the use of 8- and 16-bit Siemens / Intel type CPUs, different register addresses are defined in multiplexed and demultiplexed bus mode (see **chapter 4.1**). In the multiplexed mode even addresses are used (AD0 always 0).

For a demultiplexed μP interface mode the OMDR:RBS bit is needed in addition to the address lines A3 .. A0. With OMDR:RBS (register bank selection) one of two register banks is selected.

RBS = "1" selects a set of registers used for device initialization (e.g. CFI and PCM interface initialization).

RBS = "0" switches to a group of registers necessary during operation (e.g. connection programming).

The OMDR register containing the RBS bit can be accessed with either value of RBS.

Interrupts

An interrupt of the EPIC is indicated by activating the $\overline{\text{INT}}$ line. The detailed cause of the request can be determined by reading the ISTA register.

The $\overline{\text{INT}}$ -output is level active. It remains active until all interrupt sources have been serviced. If a new status bit is set while an interrupt is being serviced, the $\overline{\text{INT}}$ remains active. However, for the duration of a write access to the MASK-register the $\overline{\text{INT}}$ line is deactivated. When using an edge-triggered interrupt controller, it is thus recommended to rewrite the MASK-register at the end of any interrupt service routine.

Every interrupt source can be selectively masked by setting the respective bit of the MASK register. Such masked interrupts will not be indicated in the ISTA register, nor will they activate the $\overline{\text{INT}}$ line.

3.2 Clocking

To operate properly, the EPIC always requires a PDC-clock.

To synchronize the PCM side, the EPIC should normally also be provided with a PFS strobe. In most applications, the DCL and FSC will be output signals of the EPIC, derived from the PDC via prescalers.

If the required CFI data rate cannot be derived from the PDC, DCL and FSC can also be programmed as input signals. This is achieved by setting the EPIC CMD1:CSS-bit. Frequency and phase of DCL and FSC may then be chosen almost independently of the frequency and phase of PDC and PFS. However, the CFI clock source **must** still be synchronous to the PCM-interface clock source; i.e. the clock source for the CFI interface and the clock source for the PCM-interface must be derived from the same master clock.

Chapter 5.2.2 provides further details on clocking.

3.3 Reset

A reset pulse of at least 4 PDC clock cycles has to be applied at the RES pin. The reset pulse sets all registers to their reset values described in **section 4**.

The EPIC is now in CM reset mode (refer to **4.2.6.7**). As the hardware reset does not affect the EPIC memories CM and DM, a “software reset” of the CM has to be performed.

Subsequently the EPIC can be programmed to CM initialization, normal operation or test mode.

During reset the address latch enable pin ALE is evaluated to determine the bus interface type.

3.4 EPIC® Operation

The EPIC is principally an intelligent switch of PCM data between two serial interfaces, the system interface (PCM interface) and the configurable interface (CFI). Up to 128 channels per direction can be switched dynamically between the CFI and the PCM-interfaces. The EPIC performs non-blocking space and time switching for these channels which may have a bandwidth of 16, 32, 64 or 128 kbit/s.

Both interfaces can be programmed to operate at different data rates of up to 8.192 Mbit/s. The PCM interface consists of up to four duplex ports with a tristate control signal for each output line. The configurable interface can be selected to provide either four duplex ports or 8 bi-directional (I/O) ports (EPIC-S: two duplex or 4 bi-directional ports).

The configurable interface incorporates a control block (layer-1 buffer) which allows the μ P to gain access to the control channels of an IOM (ISDN-Oriented Modular) or SLD (Subscriber Line Data) interface. The EPIC can handle the layer-1 functions buffering the C/I and monitor channels for IOM compatible devices and the feature control and signaling channels for SLD compatible devices. One major application of the EPIC is therefore as line card controller on digital and analog line cards. The layer-1 and codec devices are connected to the CFI, which is then configured to operate as IOM-2, SLD or multiplexed IOM-1 interface.

The configurable interface of the EPIC can also be configured as plain PCM-interface i.e. without IOM- or SLD-frame structure. Since it's possible to operate the two serial interfaces at different data rates, the EPIC can then be used to adapt two different PCM systems.

The EPIC-1 can handle up to 32 ISDN-subscribers with their 2B + D channel structure or up to 64 analog subscribers with their 1B channel structure in IOM-configuration. In SLD- configuration up to 16 analog subscribers can be accommodated.

The EPIC-S can handle up to 16 ISDN-subscribers with their 2B + D channel structure or up to 32 analog subscribers with their 1B channel structure in IOM-configuration. In SLD- configuration up to 8 analog subscribers can be accommodated.

The system interface is used for the connection to a PCM backplane. On a typical digital line card, the EPIC switches the ISDN B channels and, if required, also the D channels to the PCM backplane. Due to its capability to dynamically switch the 16-kbit/s D channel, the EPIC is one of the fundamental building blocks for networks with either central, decentral or mixed signaling and packet data handling architecture.

3.4.1 PCM-Interface

The serial PCM interface provides up to four duplex ports consisting each of a data transmit ($\overline{\text{TxD}}$), a data receive ($\overline{\text{RxD}}$) and a tristate control ($\overline{\text{TSC}}$) line. The transmit direction is also referred to as the upstream direction, whereas the receive direction is referred to as the downstream direction.

Data is transmitted and received at normal TTL / CMOS-levels, the output drivers being of the tristate type. Unassigned time slots may be either be tristated, or programmed to transmit a defined idle value. The selection of the states “high impedance” and “idle value” can be performed with a two bit resolution. This tristate capability allows several devices to be connected together for concentrator functions. If the output driver capability of the EPIC should prove to be insufficient for a specific application, an external driver controlled by the $\overline{\text{TSC}}$ can be connected.

The **PCM-standby function** makes it possible to switch all PCM-output lines to high impedance with a single command. Internally, the device still works normally. Only the output drivers are switched off.

The number of time slots per 8-kHz frame is programmable in a wide range (from 4 to 128). In other words, the **PCM-data rate can range between 256 kbit/s up to 8.192 Mbit/s**. Since the overall switching capacity is limited to 128 time slots per direction, the number of PCM-ports also depends on the required number of time slots: in case of 32 time slots per frame (2.048 Mbit/s) for example, four highways are available, in case of 128 time slots per frame (8.192 Mbit/s), only one highway is available.

The partitioning between number of ports and number of bits per frame is defined by the **PCM mode**. There are three PCM-modes.

The timing characteristics at the PCM interface (data rate, bit shift, etc.) can be varied in a wide range, but they are the same for each of the four PCM ports, i.e. if a data rate of 2.048 Mbit/s is selected, all four ports run at this data rate of 2.048 Mbit/s.

The PCM-interface has to be clocked with a **PCM Data Clock (PDC)** signal having a frequency equal to or twice the selected PCM-data rate. In **single clock rate** operation, a frame consisting of 32 time slots, for example, requires a PDC of 2.048 MHz. In **double clock rate** operation, however, the same frame structure would require a PDC of 4.096 MHz.

For the synchronization of the time slot structure to an external PCM system, a **PCM Framing Signal (PFS)** must be applied. The EPIC evaluates the rising PFS edge to reset the internal time slot counters. In order to adapt the PFS timing to different timing requirements, the EPIC can latch the PFS-signal with either the rising or the falling PDC edge. The PFS signal defines the position of the first bit of the internal PCM frame. The actual position of the external upstream and downstream PCM frames with respect to the framing signal PFS can still be adjusted using the **PCM offset function** of the EPIC.

Operational Description

The offset can then be programmed such that PFS marks any bit number of the external frame.

Furthermore it is possible to select either the rising or falling PDC-clock edge for transmitting and sampling the PCM-data.

Usually, the repetition rate of the applied framing pulse PFS is identical to the frame period (125 μ s). If this is the case, the **loss of synchronism indication function** can be used to supervise the clock and framing signals for missing or additional clock cycles. The EPIC checks the PFS-period internally against the duration expected from the programmed data rate. If, for example, double clock operation with 32 time slots per frame is programmed, the EPIC expects 512 clock periods within one PFS period. The synchronous state is reached after the EPIC has detected two consecutive correct frames. The synchronous state is lost if one bad clock cycle is found. The synchronization status (gained or lost) can be read from an internal register and each status change generates an interrupt.

3.4.2 Configurable Interface

The serial configurable interface (CFI) can be operated either in duplex modes or in a bi-directional mode.

In **duplex modes** the EPIC-1 provides up to four ports (EPIC-S: up to two ports) consisting each of a data output (\overline{DD}) and a data input (\overline{DU}) line. The output pins are called "Data Downstream" pins and the input pins are called "Data Upstream" pins. These modes are especially suited to realize a standard serial PCM interface (PCM highway) or to implement an IOM (ISDN-Oriented Modular) interface. The IOM interface generated by the EPIC offers all the functionality like C/I- and monitor channel handling required for operating all kinds of IOM compatible layer-1 and codec devices.

In **bi-directional mode** the EPIC-1 provides eight bi-directional ports (SIP), the EPIC-S four bi-directional ports, respectively. Each time slot at any of these ports can individually be programmed as input or output. This mode is mainly intended to realize an SLD interface (Serial Line Data). In case of an SLD interface the frame consists of eight time slots where the first four time slots serve as outputs (downstream direction) and the last four serve as inputs (upstream direction). The SLD interface generated by the EPIC offers signaling and feature control channel handling.

Data is transmitted and received at normal TTL/CMOS-levels at the CFI. **Tristate or open drain output drivers** can be selected. In case of open drain drivers, external pull-up resistors are required. Unassigned output time slots may be switched to high impedance or be programmed to transmit a defined idle value. The selection between the states "high impedance" or "idle value" can be performed on a per time slot basis.

The **CFI-standby function** switches all CFI-output lines to high impedance with a single command. Internally the device still works normally, only the output drivers are switched off.

Operational Description

The number of time slots per 8-kHz frame is programmable from 2 to 128. In other words, the **CFI-data rate can range between 128 kbit/s up to 8.192 Mbit/s**. Since the overall switching capacity is limited to 128 time slots per direction, the number of CFI- ports also depends on the required number of time slots: in case of 32 time slots per frame (2.048 Mbit/s) for example, four (EPIC-S: two) highways are available, in case of 128 time slots per frame (8.192 Mbit/s), only one highway is available. Usually, the number of bits per 8-kHz frame is an integer multiple of the number of time slots per frame (1 time slot = 8 bits).

The timing characteristics at the CFI (data rate, bit shift, etc.) can be varied in a wide range, but they are the same for each of the four (EPIC-S: two) CFI-ports, i.e. if a data rate of 2.048 Mbit/s is selected, all four (EPIC-S: two) ports run at this data rate of 2.048 Mbit/s. It is thus not possible to have one port used in IOM-2 line card mode (2.048 Mbit/s) while another port is used in IOM-2 terminal mode (768 kbit/s)!

The clock and framing signals necessary to operate the configurable interface may be derived either from the clock and framing signals of the PCM interface (PDC and PFS pins), or may be fed in directly via the DCL and FSC pins.

In the first case, the CFI data rate is obtained by internally dividing down the PCM clock signal PDC. Several prescaler factors are available to obtain the most commonly used data rates. A CFI reference clock (CRCL) is generated out of the PDC-clock. The PCM-framing signal PFS is used to synchronize the CFI-frame structure. Additionally, the EPIC generates clock and framing signals as outputs to operate the connected subscriber circuits such as layer-1 and codec filter devices. The generated data clock DCL has a frequency equal to or twice the CFI data rate. The generated framing signal FSC can be chosen from a great variety of types to suit the different applications: IOM-2, multiplexed IOM-1, SLD, etc.

Note that if PFS is selected as the framing signal source, the FSC signal is an output with a fixed timing relationship with respect to the CFI data lines. The relationship between FSC and the CFI frame depends only on the selected FSC-output wave form (CMD2 register). The CFI offset function shifts both the frame and the FSC output signal with respect to the PFS signal.

In the second case, the CFI data rate is derived from the DCL-clock, which is now used as an input signal. The DCL clock may also first be divided down by internal prescalers before it serves as the CFI reference clock CRCL and before defining the CFI data rate. The framing signal FSC is used to synchronize the CFI frame structure.

3.4.3 Switching Functions

The major tasks of the EPIC part is to dynamically switch PCM data between the serial PCM interface, the serial configurable interface (CFI) and the parallel μ P interface. All possible switching paths are shown in **figure 18**.

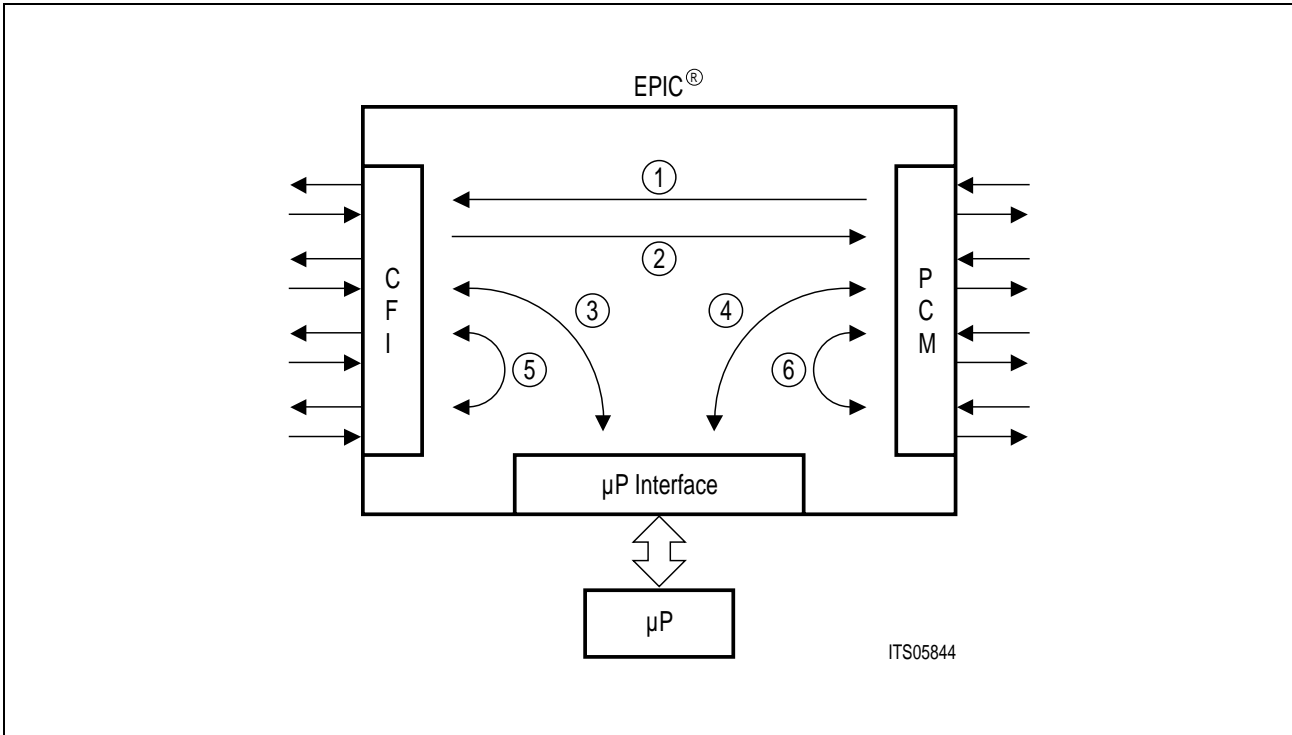

Figure 18
Switching Paths Inside the EPIC[®]-1

Note: The time slot selections in upstream direction are completely independent of the time slot selections in downstream direction.

Note: The same applies for the EPIC-S with the exception that only two CFI ports are provided.

CFI - PCM Time Slot Assignment

Switching paths 1 and 2 of **figure 18** can be realized for a total number of 128 channels (EPIC-S: 64) per path, i.e. 128 (EPIC-S: 64) time slots in upstream and 128 (EPIC-S: 64) time slots in downstream direction. To establish a connection, the μ P writes the addresses of the involved CFI and PCM time slots to the control memory. The actual transfer is then carried out frame by frame without further μ P intervention.

The switching paths 5 and 6 can be realized by programming time slot assignments in the control memory. The total number for such loops is limited to the number of available time slots at the respective opposite interface, i.e. looping back a time slot from CFI to CFI requires a spare upstream PCM time slot and looping back a time slot from PCM to PCM requires a spare downstream and upstream CFI time slot.

Time slot switching is always carried out on 8-bit time slots, the actual position and number of transferred bits can however be limited to 4-bit or 2-bit sub time slots within these 8-bit time slots. On the CFI side, only one sub time slot per 8-bit time slot can be switched, whereas on the PCM-interface up to 4 independent sub time slots can be switched.

Examples are given in **chapter 5.3**.

Sub Time Slot Switching

Sub time slot positions at the PCM-interface can be selected at random, i.e. each single PCM time slot may contain any mixture of 2- and 4-bit sub time slots. A PCM time slot may also contain more than one sub time slot. On the CFI however, two restrictions must be observed:

- Each CFI time slot may contain one and only one sub time slot.
- The sub-slot position for a given bandwidth within the time slot is fixed on a per port basis.

For more detailed information on sub-channel switching please refer to **chapter 5.4.2**.

μP Transfer

Switching paths 3 and 4 of **figure 18** can be realized for all available time slots. Path 3 can be implemented by defining the corresponding CFI time slots as “μP channels” or as “pre-processed channels”.

Each single time slot can individually be declared as “μP channel”. If this is the case, the μP can write a static 8-bit value to a downstream time slot which is then transmitted repeatedly in each frame until a new value is loaded. In upstream direction, the μP can read the received 8-bit value whenever required, no interrupts being generated.

The “**pre-processed channel**” option must always be applied to two consecutive time slots. The first of these time slots must have an even time slot number. If two time slots are declared as “pre-processed channels”, the first one can be accessed by the monitor/feature control handler, which gives access to the frame via a 16-byte FIFO. Although this function is mainly intended for IOM- or SLD-applications, it could also be used to transmit or receive a “burst” of data to or from a 64-kbit/s channel. The second pre-processed time slot, the odd one, is also accessed by the μP. In downstream direction a 4-, 6- or 8-bit static value can be transmitted. In upstream direction the received 8-bit value can be read. Additionally, a change detection mechanism will generate an interrupt upon a change in any of the selected 4, 6 or 8 bits.

Pre-processed channels are usually programmed after Control Memory (CM) reset during device initialization. Resetting the CM sets all CFI time slots to unassigned channels (CM code “0000”). Of course, pre-processed channels can also be initialized or re-initialized in the operational phase of the device.

Operational Description

To program a pair of pre-processed channels the correct code for the selected handling scheme must be written to the CM. **Figure 19** gives an overview of the available pre-processing codes and their application. For further detail, please refer to **chapter 5.5**.

| DD Application | Even Control Memory Address MAAR = 0.....0 Code Field MACR = 0111... Data Field MADR = | Odd Control Memory Address MAAR = 0.....1 Code Field MACR = 0111... Data Field MADR = | Output at the Configurable Interface Downstream Preprocessed Channels Even Time-Slot Odd Time-Slot |
|---|--|---|--|
| Decentral D Channel Handling | 1 0 0 0 1 1 C/I 1 1 | 1 0 1 1 X X X X X X X X | m m m m m m m m - - C/I m m Monitor Channel Control Channel |
| Central D Channel Handling | 1 0 1 0 1 1 C/I 1 1 | PCM Code for a 2 Bit Sub. Time-Slot Pointer to a PCM Time-Slot | m m m m m m m m D D C/I m m Monitor Channel Control Channel |
| 6 Bit Signaling (e.g. analog IOM [®]) | 1 0 1 0 SIG 1 1 | 1 0 1 1 X X X X X X X X | m m m m m m m m SIG m m Monitor Channel Control Channel |
| 8 Bit Signaling (e.g. SLD) | 1 0 1 0 SIG | 1 0 1 1 X X X X X X X X | m m m m m m m m SIG Feature Control Channel Signaling Channel |

| DD Application | Even Control Memory Address MAAR = 1.....0 Code Field MACR = 0111... Data Field MADR = | Odd Control Memory Address MAAR = 1.....1 Code Field MACR = 0111... Data Field MADR = | Input from the Configurable Interface Upstream Preprocessed Channels Even Time-Slot Odd Time-Slot |
|---|--|---|---|
| Decentral D Channel Handling | 1 0 0 0 1 1 C/I 1 1 | 0 0 0 0 X X X X X X X X | m m m m m m m m - - C/I m m Monitor Channel Control Channel |
| Central D Channel Handling | 1 0 0 0 1 1 C/I 1 1 | PCM Code for a 2 Bit Sub. Time-Slot Pointer to a PCM Time-Slot | m m m m m m m m D D C/I m m Monitor Channel Control Channel |
| 6 Bit Signaling (e.g. analog IOM [®]) | 1 0 1 0 SIG Actual Value X X | 1 0 1 0 SIG Stable Value X X | m m m m m m m m SIG m m Monitor Channel Control Channel |
| 8 Bit Signaling (e.g. SLD) | 1 0 1 1 SIG Actual Value | 1 0 1 1 SIG Stable Value | m m m m m m m m SIG Feature Control Channel Signaling Channel |

m : Monitor channel bits, these bits are treated by the monitor/feature control handler

- : Inactive sub. time-slot, in downstream direction these bits are tristated (OMDR : COS = 0) or set to logical 1 (OMDR : COS = 1)

C/I : Command/Indication channel, these bits are exchanged between the CFI in/output and the CM data field. A change of the C/I bits in upstream direction causes an interrupt (ISTA : SFI). The address of the change is stored in the CIFIFO

D : D channel, these D channel bits are transparently switched to and from the PCM interface.

SIG : Signaling Channel, these bits are exchanged between the CFI in/output and the CM data field. The SIG value which actual value was present in the last frame is stored as the actual value in the even address CM location. The stable value is updated stable value if a valid change in the actual value has been detected according to the last look algorithm. A change of the SIG stable value in upstream direction causes an interrupt (ISTA : CFI). The address of the change is stored in the CIFIFO.

ITD09544

Figure 19
Pre-processed Channel Codes

Synchronous Transfer

For two channels, all switching paths of **figure 18** can also be realized using Synchronous Transfer. The working principle is that the μP specifies an input time slot (source) and an output time slot (destination). Both source and destination time slots can be selected independently from each other at either the PCM or CFI interfaces. In each frame, the EPIC first transfers the serial data from the source time slot to an internal data register from where it can be read and if required overwritten or modified by the μP . This data is then fed forward to the destination time slot.

Chapter 5.7 provides examples of such transfers.

3.4.4 Special Functions

Hardware Timer

The EPIC-1 provides a hardware timer which continuously interrupts the μP after programmable time periods. The timer period can be selected in the range of 250 μs up to 32 ms in multiples of 250 μs . Beside the interrupt generation, the timer can also be used to determine the last look period for 6- and 8-bit signaling channels on IOM-2 and SLD interfaces and for the generation of an FSC multiframe signal (see **chapter 5.8.1**).

Power and Clock Supply Supervision

The Connection Memory CM is supervised to data falsification due to clock or power failure. If such an inappropriate clocking or power failure occurs, the μP is requested to reinitialize the device.

3.5 Initialization Procedure

For proper initialization of the EPIC the following procedure is recommended:

3.5.1 Hardware Reset

A reset pulse can be applied at the RES pin for at least 4 PDC clock cycles. The reset pulse sets all registers to their reset values (refer to **chapter 4.1**).

Note: In this state DCL and FSC do not provide any clock signals.

3.5.2 EPIC® Initialization

3.5.2.1 Register Initialization

The PCM and CFI configuration registers (PMOD, PBNR, ..., CMD1, CMD2, ...) have to be programmed to the values required for the application. The correct setting of the PCM and CFI registers is important in order to obtain a reference clock (RCL) which is consistent with the externally applied clock signals.

The state of the operation mode (OMDR:OMS1..0 bits) does not matter for this programming step.

| | | |
|------|---|--|
| PMOD | = | PCM-mode, timing characteristics, etc. |
| PBNR | = | Number of bits per PCM-frame |
| POFD | = | PCM-offset downstream |
| POFU | = | PCM-offset upstream |
| PCSR | = | PCM-timing |
| CMD1 | = | CFI-mode, timing characteristics, etc. |
| CMD2 | = | CFI-timing |
| CBNR | = | Number of bits per CFI-frame |
| CTAR | = | CFI-offset (time slots) |
| CBSR | = | CFI-offset (bits) |
| CSCR | = | CFI-sub channel positions |

3.5.2.2 Control Memory Reset

Since the hardware reset does not affect the EPIC memories (Control and Data Memories), it is mandatory to perform a “software reset” of the CM. The CM code “0000”_B (unassigned channel) should be written to each location of the CM. The data written to the CM data field is then don’t care, e.g. FF_H.

OMDR:OMS1..0 must be to “00”_B for this procedure (reset value).

| | | |
|-------------------------|---|-----------------|
| MADR | = | FF _H |
| MACR | = | 70 _H |
| Wait for STAR:MAC = “0” | | |

The resetting of the complete CM takes 256 RCL clock cycles. During this time, the STAR:MAC-bit is set to logical “1”.

3.5.2.3 Initialization of Pre-processed Channels

After the CM reset, all CFI time slots are unassigned. If the CFI is used as a plain PCM interface, i.e. containing only switched channels (B channels), the initialization steps below are not required. The initialization of pre-processed channels applies only to IOM or SLD applications.

An IOM or SLD “channel” consists of four consecutive time slots. The first two time slots, the B channels need not be initialized since they are already set to unassigned channels by the CM reset command. Later, in the application phase of the software, the B channels can be dynamically switched according to system requirements. The last two time slots of such an IOM or SLD channel, the pre-processed channels must be initialized for the desired functionality. There are four options that can be selected:

**Table 2
Pre-processed Channel Options at the CFI**

| Even CFI Time Slot | Odd CFI Time Slot | Main Application |
|---------------------------------|--|-----------------------------------|
| Monitor/feature control channel | 4-bit C/I channel, D channel not switched (decentral D channel handling) | IOM-1 or IOM-2 digital subscriber |
| Monitor/feature control channel | 4-bit C/I channel, D channel switched (central D ch. handling) | IOM-1 or IOM-2 digital subscriber |
| Monitor/feature control channel | 6-bit SIG channel | IOM-2, analog subscriber |
| Monitor/feature control channel | 8-bit SIG/channel | SLD, analog subscriber |

Also refer to **figure 19**.

Example

In CFI-mode 0 all four CFI-ports shall be initialized as IOM-2 ports with a 4-bit C/I-field and decentral D channel handling.

CFI time slots 0, 1, 4, 5, 8, 9 ... 28, 29 of each port are B channels and need not to be initialized.

CFI time slots 2, 3, 6, 7, 10, 11, ..., 30, 31 of each port are pre-processed channels and need to be initialized:

CFI-port 0, time slot 2 (even), downstream

MADR = FF_H ; the C/I-value "1111" will be transmitted upon CFI activation
MAAR = 08_H ; addresses ts 2 down
MACR = 78_H ; CM-code "1000"
Wait for STAR:MAC = 0

CFI-port 0, time slot 3 (odd), downstream

MADR = FF_H ; don't care
MAAR = 09_H ; addresses ts 3 down
MACR = 7B_H ; CM-code "1011"
Wait for STAR:MAC = 0

CFI-port 0, time slot 2 (even), upstream

MADR = FF_H ; the C/I-value "1111" is expected upon CFI activation
MAAR = 88_H ; address ts 2 up
MACR = 78_H ; CM-code "1000"
Wait for STAR:MAC = 0

CFI-port 0, time slot 3 (odd), upstream

MADR = FF_H ; don't care
MAAR = 89_H ; address ts 3 up
MACR = 70_H ; CM-code "0000"
Wait for STAR:MAC = 0

Repeat the above programming steps for the remaining CFI ports and time slots.

This procedure can be speeded up by selecting the CM initialization mode (OMDR:OMS1..0 = 10). If this selection is made, the access time to a single memory location is reduced to 2.5 RCL cycles. The complete initialization time for 32 IOM-2 channels is then reduced to $128 \times 0.61 \mu\text{s} = 78 \mu\text{s}$.

3.5.2.4 Initialization of the Upstream Data Memory (DM) Tristate Field

For each PCM time slot the tristate field defines whether the contents of the DM data field are to be transmitted (low impedance), or whether the PCM time slot shall be set to high impedance. The contents of the tristate field is not modified by a hardware reset. In order to have all PCM time slots set to high impedance upon the activation of the PCM-interface, each location of the tristate field must be loaded with the value '0000'. For this purpose, the 'tristate reset' command can be used:

```
OMDR = C0H ; OMS1..0 = 11, normal mode
MADR = 00H ; code field value "0000"B
MACR = 68H ; MOC-code to initialize all tristate locations (1101B)
Wait for STAR:MAC = 0
```

The initialization of the complete tristate field takes 1035 RCL cycles.

Note: It is also possible to program the value "0000" to the tristate field in order to have all time slots switched to low impedance upon the activation of the PCM interface.

Note: While OMDR:PSB = 0, all PCM-output drivers are set to high impedance, regardless of the values written to the tristate field.

3.5.3 Activation of the PCM and CFI Interfaces

With the EPIC configured to the system requirements, the PCM and CFI interface can be switched to the operational mode.

The OMDR:OMS1..0 bits must be set (if this has not already be done) to the normal operation mode (OMS1..0 = 11). When doing this, the PCM framing interrupt (ISTA:PFI) will be enabled. If the applied clock and framing signals are in accordance with the values programmed to the PCM-registers, the PFI interrupt will be generated (if not masked). When reading the status register, the STAR:PSS-bit will be set to logical 1.

To enable the PCM-output drivers set OMDR:PSB = 1. The CFI interface is activated by programming OMDR:CSB = 1. This enables the output clock and framing signals (DCL and FSC), if these have been programmed as outputs. It also enables the CFI output drivers. The output driver type can be selected between "open drain" and "tristate" with the OMDR:COS bit.

Example: Activation of the EPIC for a typical IOM-2 application:

```
OMDR = EEH;   Normal operation mode (OMS1..0 = 11)
              PCM interface active (PSB = 1)
              PCM test loop disabled (PTL = 0)
              CFI output drivers: open drain (COS = 1)
              Monitor handshake protocol selected (MFPS = 1)
              CFI active (CSB = 1)
              Access to EPIC registers via address pins A3..A0, used in
              demultiplexed mode only, normal operation (RBS = 0)
```

Detailed Register Description

4 Detailed Register Description

4.1 Register Address Arrangement

| Group | Reg. Name | Access | Address mux AD7..0 | Address demux OMDR:RBS/A3..0 | Reset Value | Comment | Refer to page |
|----------------------|-----------|--------|--------------------|------------------------------|-----------------|---|---------------|
| PCM interface | PMOD | RD/WR | 20 _H | 1/0 _H | 00 _H | PCM-mode reg. | 48 |
| | PBNR | RD/WR | 22 _H | 1/1 _H | FF _H | PCM-bit number reg. | 50 |
| | POFD | RD/WR | 24 _H | 1/2 _H | 00 _H | PCM-offset downstream reg. | 50 |
| | POFU | RD/WR | 26 _H | 1/3 _H | 00 _H | PCM-offset upstream reg. | 51 |
| | PCSR | RD/WR | 28 _H | 1/4 _H | 00 _H | PCM-clock shift reg. | 51 |
| | PICM | RD | 2A _H | 1/5 _H | xx _H | PCM-input comparison mismatch reg. | 52 |
| CFI interface | CMD1 | RD/WR | 2C _H | 1/6 _H | 00 _H | CFI-mode reg. 1 | 53 |
| | CMD2 | RD/WR | 2E _H | 1/7 _H | 00 _H | CFI-mode reg. 2 | 55 |
| | CBNR | RD/WR | 30 _H | 1/8 _H | FF _H | CFI-bit number reg. | 58 |
| | CTAR | RD/WR | 32 _H | 1/9 _H | 00 _H | CFI time slot adjustment reg. | 58 |
| | CBSR | RD/WR | 34 _H | 1/A _H | 00 _H | CFI-bit shift reg. | 59 |
| | CSCR | RD/WR | 36 _H | 1/B _H | 00 _H | CFI-subchannel reg. | 60 |
| Memory access | MACR | RD/WR | 00 _H | 0/0 _H | xx _H | Memory access control reg. | 61 |
| | MAAR | RD/WR | 02 _H | 0/1 _H | xx _H | Memory access address reg. | 65 |
| | MADR | RD/WR | 04 _H | 0/2 _H | xx _H | Memory access data reg. | 66 |
| Synchronous transfer | STDA | RD/WR | 06 _H | 0/3 _H | xx _H | Synchron transfer data reg. A | 67 |
| | STDB | RD/WR | 08 _H | 0/4 _H | xx _H | Synchron transfer data reg. B | 67 |
| | SARA | RD/WR | 0A _H | 0/5 _H | xx _H | Synchron transfer receive address reg. A | 68 |
| | SARB | RD/WR | 0C _H | 0/6 _H | xx _H | Synchron transfer receive address reg. B | 69 |
| | SAXA | RD/WR | 0E _H | 0/7 _H | xx _H | Synchron transfer transmit address reg. A | 69 |
| | SAXB | RD/WR | 10 _H | 0/8 _H | xx _H | Synchron transfer transmit address reg. B | 70 |
| | STCR | RD/WR | 12 _H | 0/9 _H | 00xxxxxx | Synchron transfer control reg. | 70 |

Detailed Register Description

4.1 Register Address Arrangement (cont'd)

| Group | Reg. Name | Access | Address mux AD7..0 | Address demux OMDR:RBS/A3..0 | Reset Value | Comment | Refer to page |
|--------------------------------|-----------|-----------------|------------------------------------|------------------------------|--------------------------------|------------------------------------|---------------|
| Monitor/ feature control | MFAIR | RD | 14 _H | 0/A _H | 00 _H | MF-channel active indication reg. | 71 |
| | MFSAR | WR | 14 _H | 0/A _H | 00 _H | MF-channel subscriber address reg. | 72 |
| | MFFIFO | RD/WR | 16 _H | 0/B _H | xx _H | MF-channel FIFO | 73 |
| Status/ control | CIFIFO | RD | 18 _H | 0/C _H | 0xxxxx xx | Signaling channel FIFO | 73 |
| | TIMR | WR | 18 _H | 0/C _H | 00 _H | Timer reg. | 74 |
| | STAR | RD | 1A _H | 0/D _H | 05 _H | Status register EPIC | 75 |
| | CMDR | WR | 1A _H | 0/D _H | 00 _H | Command reg. EPIC | 76 |
| | ISTA | RD | 1C _H | 0/E _H | 00 _H | Interrupt status EPIC-1 | 78 |
| | MASK | WR | 1C _H | 0/E _H | 00 _H | Mask register EPIC-1 | 79 |
| | OMDR | RD/WR | 1E _H 3E _H | x/F _H | 00 _H | Operation mode reg. | 80 |
| VNSR | RD/WR | 3A _H | 1/D _H | 00 _H | Version number status register | 82 | |

Detailed Register Description

4.2 Detailed Register Description

4.2.1 PCM Interface Registers

4.2.1.1 PCM-Mode Register (PMD)

Access in demultiplexed μ P-interface mode: read/write address: 0_H, OMDR:RBS = 1
 Access in multiplexed μ P-interface mode: read/write address: 20_H
 Reset value: 00_H

| | | | | | | | |
|-------|------|-----|-----|-------|------|------|------|
| bit 7 | | | | bit 0 | | | |
| PMD1 | PMD0 | PCR | PSM | AIS1 | AIS0 | AIC1 | AIC0 |

PMD1..0 PCM Mode. Defines the actual number of PCM ports, the data rate range and the data rate stepping.

| PMD1..0 | PCM Mode | Port Count | Data Rate [kbit/s] | | Data Rate Stepping [kbit/s] |
|---------|----------|------------|--------------------|------|-----------------------------|
| | | | min. | max. | |
| 00 | 0 | 4 | 256 | 2048 | 256 |
| 01 | 1 | 2 | 512 | 4096 | 512 |
| 10 | 2 | 1 | 1024 | 8192 | 1024 |

The actual selection of physical pins is described below (AIS1/0).

PCR PCM Clock Rate.
 0... single clock rate, data rate is identical with the clock frequency supplied on pin PDC.
 1... double clock rate, data rate is half the clock frequency supplied on pin PDC.

Note: Only single clock rate is allowed in PCM-mode 2!

PSM PCM Synchronization Mode.
 A rising edge on PFS synchronizes the PCM frame. PFS is not evaluated directly but is sampled with PDC.
 0... the external PFS is evaluated with the falling edge of PDC. The internal PFS (internal frame start) occurs with the next rising edge of PDC.
 1... the external PFS is evaluated with the rising edge of PDC. The internal PFS (internal frame start) occurs with this rising edge of PDC.

Detailed Register Description

AIS1..0 Alternative Input Selection.

These bits determine the relationship between the physical pins and the logical port numbers. The logical port numbers are used when programming the switching functions.

Note: In PCM-mode 0 these bits may not be set!

| PCM Mode | Port 0 | | | Port 1 | | | Port 2 | | | Port 3 | | |
|----------|-----------------|------|-------------------|-----------------|----------|-------------------|-----------------|--------|-------------------|-----------------|----------|-------------------|
| | RxD0 | TxD0 | $\overline{TSC0}$ | RxD1 | TxD1 | $\overline{TSC1}$ | RxD2 | TxD2 | $\overline{TSC2}$ | RxD3 | TxD3 | $\overline{TSC3}$ |
| 0 | IN0 | OUT0 | val0 | IN1 | OUT1 | val1 | IN2 | OUT2 | val2 | IN3 | OUT3 | val3 |
| 1 | IN0 (AIS0=1) | OUT0 | val0 | IN0 (AIS0=0) | tristate | AIS0 | IN1 (AIS1=1) | OUT1 | val1 | IN1 (AIS1=0) | tristate | AIS1 |
| 2 | not active | OUT | val | not active | tristate | AIS0 | IN (AIS1=1) | undef. | undef. | IN (AIS1=0) | tristate | AIS1 |

AIC1 Alternate Input Comparison 1.

0...input comparison of port 2 and 3 is disabled
1...the inputs of port 2 and 3 are compared

AIC0 Alternate Input Comparison 0.

0...input comparison of port 0 and 1 is disabled
1...the inputs of port 0 and 1 are compared

Note: The comparison function is operational in all PCM modes; however, a redundant PCM line which can be switched over to by means of the PMOD:AIS bits is only available in PCM modes 1 and 2.

Detailed Register Description

4.2.1.2 Bit Number per PCM-Frame (PBNR)

Access in demultiplexed μ P-interface mode: read/write address: 1_H
OMDR:RBS = 1
Access in multiplexed μ P-interface mode: read/write address: 22_H
Reset value: FF_H

| | | | | | | | |
|-------|------|------|------|-------|------|------|------|
| bit 7 | | | | bit 0 | | | |
| BNF7 | BNF6 | BNF5 | BNF4 | BNF3 | BNF2 | BNF1 | BNF0 |

BNF7..0 Bit Number per PCM Frame.

PCM-mode 0: BNF7..0 = number of bits – 1
PCM-mode 1: BNF7..0 = (number of bits – 2) / 2
PCM-mode 2: BNF7..0 = (number of bits – 4) / 4

The value programmed in PBNR is also used to check the PFS period.

4.2.1.3 PCM-Offset Downstream Register (POFD)

Access in demultiplexed μ P-interface mode: read/write address: 2_H
OMDR:RBS = 1
Access in multiplexed μ P-interface mode: read/write address: 24_H
Reset value: 00_H

| | | | | | | | |
|-------|------|------|------|-------|------|------|------|
| bit 7 | | | | bit 0 | | | |
| OFD9 | OFD8 | OFD7 | OFD6 | OFD5 | OFD4 | OFD3 | OFD2 |

OFD9..2 Offset Downstream bit 9...2.

These bits together with PCSR:OFD1..0 determine the offset of the PCM frame in downstream direction. The following formulas apply for calculating the required register value. BND is the bit number in downstream direction marked by the rising internal PFS edge. BPF denotes the actual number of bits constituting a frame.

PCM mode 0: OFD9..2 = mod_{BPF} (BND – 17 + BPF)
PCSR:OFD1..0 = 0
PCM mode 1: OFD9..1 = mod_{BPF} (BND – 33 + BPF)
PCSR: PFD0 = 0
PCM mode 2: OFD9..0 = mod_{BPF} (BND – 65 + BPF)

Detailed Register Description

4.2.1.4 PCM-Offset Upstream Register (POFU)

Access in demultiplexed μ P-interface mode: read/write address: 3_H
OMDR:RBS = 1
Access in multiplexed μ P-interface mode: read/write address: 26_H
Reset value: 00_H

| | | | | | | | |
|-------|------|------|------|------|------|-------|------|
| bit 7 | | | | | | bit 0 | |
| OFU9 | OFU8 | OFU7 | OFU6 | OFU5 | OFU4 | OFU3 | OFU2 |

OFU9..2 Offset Upstream bit 9...2.

These bits together with PCSR:OFU1..0 determine the offset of the PCM frame in upstream direction. The following formulas apply for calculating the required register value. BNU is the bit number in upstream direction marked by the rising internal PFS-edge.

PCM mode 0: OFU9..2 = mod_{BPF} (BNU + 23)
PCSR:OFU1..0 = 00

PCM mode 1: OFU9..1 = mod_{BPF} (BNU + 47)
PCSR:OFU0 = 0

PCM mode 2: OFU9..0 = mod_{BPF} (BNU + 95)

4.2.1.5 PCM-Clock Shift Register (PCSR)

Access in demultiplexed μ P-interface mode: read/write address: 4_H
OMDR:RBS = 1
Access in multiplexed μ P-interface mode: read/write address: 28_H
Reset value: 00_H

| | | | | | | | |
|-------|------|------|-----|---|-------|------|-----|
| bit 7 | | | | | bit 0 | | |
| 0 | OFD1 | OFD0 | DRE | 0 | OFU1 | OFU0 | URE |

OFD1..0 Offset Downstream bits 1...0, **see POFD register.**

DRE Downstream Rising Edge.
0...the PCM-data is sampled with the falling edge of PDC
1...the PCM-data is sampled with the rising edge of PDC

OFU1..0 Offset Upstream bits 1...0, **see POFU register.**

URE Upstream Rising Edge.
0...the PCM-data is transmitted with the falling edge of PDC
1...the PCM-data is transmitted with the rising edge of PDC

Detailed Register Description

4.2.1.6 PCM-Input Comparison Mismatch (PICM)

Access in demultiplexed μ P-interface mode: read address: 5_H
 OMDR:RBS = 1
 Access in multiplexed μ P-interface mode: read/write address: $2A_H$
 Reset value: xx_H

bit 7

bit 0

| | | | | | | | |
|-----|------|------|------|------|------|------|------|
| IPN | TSN6 | TSN5 | TSN4 | TSN3 | TSN2 | TSN1 | TSN0 |
|-----|------|------|------|------|------|------|------|

IPN Input Pair Number.
 This bit denotes the pair of ports, where a bit mismatch occurred.
 0...mismatch between ports 0 and 1
 1...mismatch between ports 2 and 3

TSN6..0 Time Slot Number.
 When a bit mismatch occurred these bits identify the affected bit position.

| PCM Mode | Time Slot Identification | Bit Identification |
|----------|--------------------------|--|
| 0 | TSN6...TSN2 + 2 | TSN1,0= 00: bits 6,7 01: bits 4,5 10: bits 2,3 11: bits 0,1 |
| 1 | TSN6...TSN1 + 4 | TSN0= 0: bits 4...7 1: bits 0...3 |
| 2 | TSN6...TSN0 + 8 | |

Detailed Register Description

4.2.2 Configurable Interface Registers

4.2.2.1 Configurable Interface Mode Register 1 (CMD1)

Access in demultiplexed μ P-interface mode: read/write address: 6_H
OMDR:RBS = 1
Access in multiplexed μ P-interface mode: read/write address: 2C_H
Reset value: 00_H

| | |
|-------|-------|
| bit 7 | bit 0 |
| CSS | CIS0 |

- CSS** Clock Source Selection.
0...PDC and PFS are used as clock and framing source for the CFI. Clock and framing signals derived from these sources are output on DCL and FSC.
1...DCL and FSC are selected as clock and framing source for the CFI.
- CSM** CFI-Synchronization Mode.
The rising FSC edge synchronizes the CFI-frame.
0...FSC is evaluated with every falling edge of DCL.
1...FSC is evaluated with every rising edge of DCL.
Note: If CSS = 0 is selected, CSM and PMOD:PSM must be programmed identical.
- CSP1..0** Clock Source Prescaler 1,0.
The clock source frequency is divided according to the following table to obtain the CFI reference clock CRCL.

| CSP1,0 | Prescaler Divisor |
|--------|-------------------|
| 00 | 2 |
| 01 | 1.5 |
| 10 | 1 |
| 11 | not allowed |

Detailed Register Description

CMD1..0 CFI Mode1,0.

Defines the actual number and configuration of the CFI ports.

| CMD1..0 | CFI Mode | Number of Logical Ports | CFI Data Rate [kbit/s] | | Min. Required CFI Data Rate [kbit/s] Relative to PCM-Data Rate | Necessary Reference Clock (RCL) | DCL-Output Frequencies CMD1:CSS0 = 0 |
|---------|----------|-------------------------|------------------------|------|--|---------------------------------|---|
| | | | min. | max. | | | |
| 00 | 0 | 4 DU (0..3) | 128 | 2048 | 32N/3 | 2xDR | DR, 2xDR ¹⁾ |
| 01 | 1 | 2 DU (0..1) | 128 | 4096 | 64N/3 | DR | DR |
| 10 | 2 | 1 DU | 128 | 8192 | 64N/3 | 0.5xDR | DR |
| 11 | 3 | 8 bi (0..7) | 128 | 1024 | 16N/3 | 4xDR | DR, 2xDR |

where N = number of time slots in a PCM frame

CIS1..0 CFI Alternative Input Selection.

In CFI mode 1 and 2 CIS1..0 controls the assignment between logical and physical receive pins. In CFI mode 0 and 3 CIS1,0 should be set to 0.

| CFI Mode | Port 0 | | Port 1 | | Port 2 | | Port 3 | |
|----------|-----------------|------|-----------------|----------|-----------------|----------|-----------------|----------|
| | DU0 | DD0 | DU1 | DD1 | DU2 | DD2 | DU3 | DD3 |
| 0 | IN0 | OUT0 | IN1 | OUT1 | IN2 | OUT2 | IN3 | OUT3 |
| 1 | IN0 CIS0 = 0 | OUT0 | IN1 CIS1 = 0 | OUT1 | IN0 CIS0 = 1 | tristate | IN1 CIS1 = 1 | tristate |
| 2 | IN CIS0 = 0 | OUT | not active | tristate | IN CIS0 = 1 | tristate | not active | tristate |
| 3 | I/O4 | I/O0 | I/O5 | I/O1 | I/O6 | I/O2 | I/O7 | I/O3 |

Detailed Register Description

4.2.2.2 Configurable Interface Mode Register 2 (CMD2)

Access in demultiplexed μ P-interface mode: read/write address: 7_H
 OMDR:RBS = 1
 Access in multiplexed μ P-interface mode: read/write address: 2E_H
 Reset value: 00_H

| | | | | | | | |
|-------|-----|-----|-----|-----|-----|------|-------|
| bit 7 | | | | | | | bit 0 |
| FC2 | FC1 | FC0 | COC | CXF | CRR | CBN9 | CBN8 |

FC2..0 Framing output Control.
 Given that CMD1:CSS = 0, these bits determine the position of the FSC pulse relative to the CFI frame, as well as the type of FSC pulse generated. The position and width of the FSC signal with respect to the CFI frame can be found in the following two **figures 20** and **21**.

Detailed Register Description

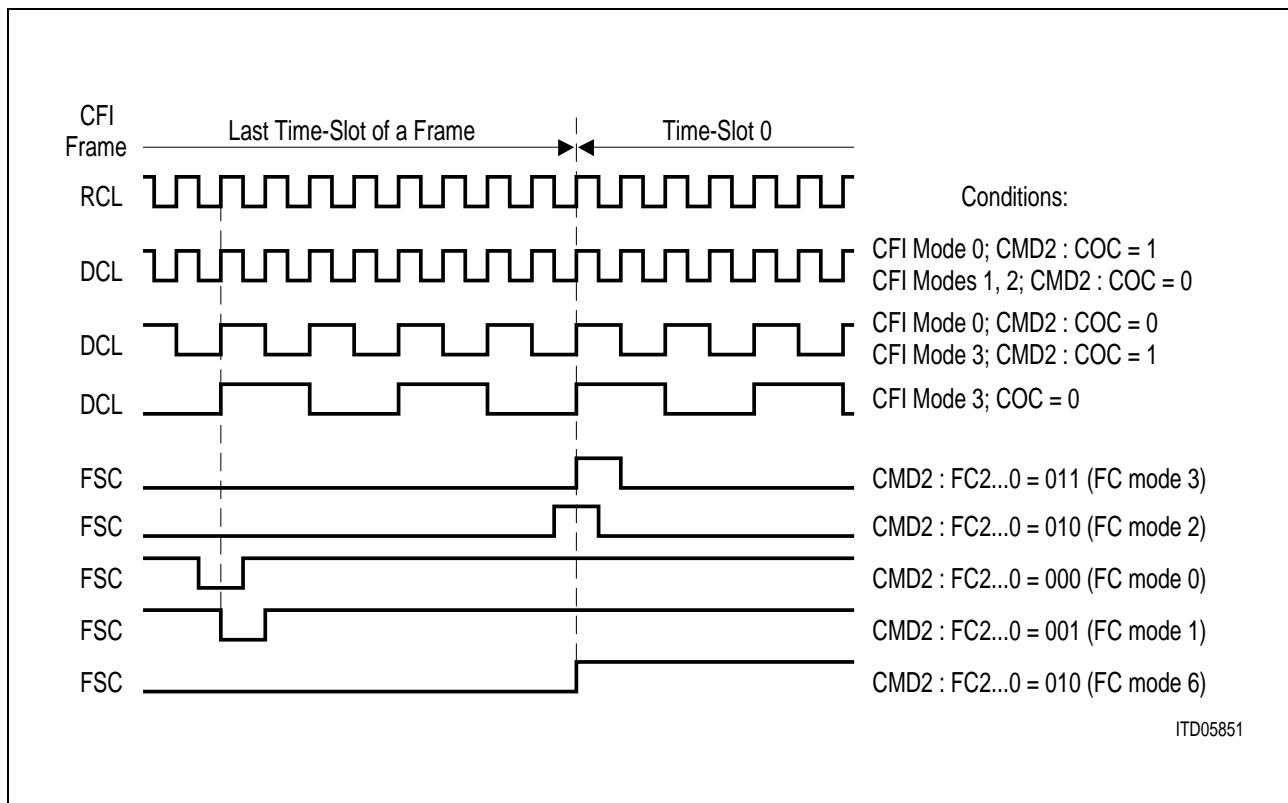

Figure 20
Position of the FSC Signal for FC Modes 0, 1, 2, 3 and 6

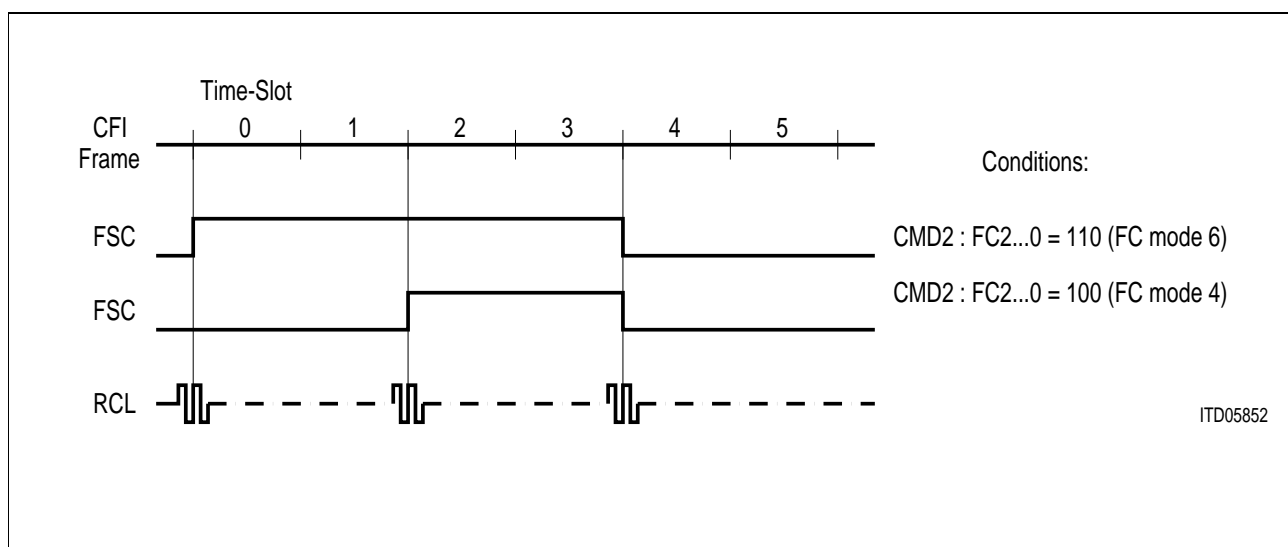

Figure 21
Position of the FSC Signal for FC Modes 4 and 6

Detailed Register Description

Application examples:

| FC2 | FC1 | FC0 | FC-Mode | Main Applications |
|-----|-----|-----|---------|---|
| 0 | 0 | 0 | 0 | IOM-1 multiplexed (burst) mode |
| 0 | 0 | 1 | 1 | general purpose |
| 0 | 1 | 0 | 2 | general purpose |
| 0 | 1 | 1 | 3 | general purpose |
| 1 | 0 | 0 | 4 | 2 ISAC-S per SLD-port |
| 1 | 0 | 1 | 5 | reserved |
| 1 | 1 | 0 | 6 | IOM-2 or SLD modes |
| 1 | 1 | 1 | 7 | software timed multiplexed applications |

For further details on the framing output control please refer to **chapter 5.2.2.3**.

- COC** CFI Output Clock rate.
 0...the frequency of DCL is identical to the CFI data rate (all CFI modes),
 1...the frequency of DCL is twice the CFI data rate (CFI modes 0 and 3 only!)
Note:Applies only if CMD1:CSS = 0.
- CXF** CFI Transmit on Falling edge.
 0...the data is transmitted with the rising CRCL edge,
 1...the data is transmitted with the falling CRCL edge.
- CRR** CFI Receive on Rising edge.
 0...the data is received with the falling CRCL edge,
 1...the data is received with the rising CRCL edge.
Note:CRR must be set to 0 in CFI-mode 3.
- CBN9..8** CFI Bit Number 9..8
 these bits, together with the CBNR:CBN7..0, hold the number of bits per CFI frame.

Detailed Register Description

4.2.2.3 Configurable Interface Bit Number Register (CBNR)

Access in demultiplexed μ P-interface mode: read/write address: 8_H
OMDR:RBS = 1
Access in multiplexed μ P-interface mode: read/write address: 30_H
Reset value: FF_H

| | | | | | | | |
|-------|------|------|------|------|------|------|-------|
| bit 7 | | | | | | | bit 0 |
| CBN7 | CBN6 | CBN5 | CBN4 | CBN3 | CBN2 | CBN1 | CBN0 |

CBN7..0 CFI Bit Number 7..0.
The number of bits that constitute a CFI frame must be programmed to CMD2, CBNR:CBN9..0 as indicated below.
CBN9..0 = number of bits – 1
For a 8-kHz frame structure, the number of bits per frame can be derived from the data rate by division with 8000.

4.2.2.4 Configurable Interface Time Slot Adjustment Register (CTAR)

Access in demultiplexed μ P-interface mode: read/write address: 9_H
OMDR:RBS = 1
Access in multiplexed μ P-interface mode: read/write address: 32_H
Reset value: 00_H

| | | | | | | | |
|-------|------|------|------|------|------|------|-------|
| bit 7 | | | | | | | bit 0 |
| 0 | TSN6 | TSN5 | TSN4 | TSN3 | TSN2 | TSN1 | TSN0 |

TSN6..0 Time Slot Number.
The CFI framing signal (PFS if CMD1:CSS = 0 or FSC if CMD1:CSS = 1) marks the CFI time slot called TSN according to the following formula:
TSN6..0 = TSN + 2
E.g.: If the framing signal is to mark time slot 0 (bit 7), CTAR must be set to 02_H (CBSR to 20_H).

*Note: If CMD1:CSS = 0, the CFI frame will be shifted - together with the FSC output signal - with respect to PFS. The position of the CFI frame relative to the FSC output signal is not affected by these settings, but is instead determined by CMD2:FC2..0.
If CMD1:CSS = 1, the CFI frame will be shifted with respect to the FSC-input signal.*

Detailed Register Description

4.2.2.5 Configurable Interface Bit Shift Register (CBSR)

Access in demultiplexed μ P-interface mode: read/write address: A_H
 OMDR:RBS = 1
 Access in multiplexed μ P-interface mode: read/write address: 34_H
 Reset value: 00_H

| | | | | | | | |
|-------|------|------|------|------|------|------|-------|
| bit 7 | | | | | | | bit 0 |
| 0 | CDS2 | CDS1 | CDS0 | CUS3 | CUS2 | CUS1 | CUS0 |

CDS2..0 CFI Downstream bit Shift 2..0.
 From the zero offset bit position ($CBSR = 20_H$) the CFI frame (downstream and upstream) can be shifted by up to 6 bits to the left (within the time slot number TSN programmed in CTAR) and by up to 2 bits to the right (within the previous time slot $TSN - 1$) by programming the $CBSR:CDS2..0$ bits:

| CBSR:CDS2..0 | Time Slot No. | Bit No. |
|---------------------|----------------------|----------------|
| 000 | $TSN - 1$ | 1 |
| 001 | $TSN - 1$ | 0 |
| 010 | TSN | 7 |
| 011 | TSN | 6 |
| 100 | TSN | 5 |
| 101 | TSN | 4 |
| 110 | TSN | 3 |
| 111 | TSN | 2 |

The bit shift programmed to $CBSR:CDS2..0$ affects both the upstream and downstream frame position in the same way.

CUS3..0 CFI Upstream bit Shift 3..0.
 These bits shift the upstream CFI frame relative to the downstream frame by up to 15 bits. For $CUS3..0 = 0000$, the upstream frame is aligned with the downstream frame (no bit shift).

Detailed Register Description

4.2.2.6 Configurable Interface Subchannel Register (CSCR)

Access in demultiplexed μ P-interface mode: read/write address: B_H
 OMDR:RBS = 1
 Access in multiplexed μ P-interface mode: read/write address: 36_H
 Reset value: 00_H

| | | | | | | | | | |
|-------|------|------|------|------|------|------|------|------|-------|
| bit 7 | SC31 | SC30 | SC21 | SC20 | SC11 | SC10 | SC01 | SC00 | bit 0 |
|-------|------|------|------|------|------|------|------|------|-------|

SC#1..#0 CFI Subchannel Control for logical port #.
 The subchannel control bits SC#1..SC#0 specify separately for each logical port the bit positions to be exchanged with the data memory (DM) when a connection with a channel bandwidth as defined by the CM-code has been established:

| SC#1 | SC#0 | Bit Positions for CFI Subchannels having a Bandwidth of | | |
|------|------|---|-----------|-----------|
| | | 64 kbit/s | 32 kbit/s | 16 kbit/s |
| 0 | 0 | 7..0 | 7..4 | 7..6 |
| 0 | 1 | 7..0 | 3..0 | 5..4 |
| 1 | 0 | 7..0 | 7..4 | 3..2 |
| 1 | 1 | 7..0 | 3..0 | 1..0 |

*Note: In CFI-mode 1: SC21 = SC01; SC20 = SC00; SC31 = SC11; SC30 = SC10
 In CFI-mode 2: SC31 = SC21 = SC11 = SC01; SC30 = SC20 = SC10 = SC00
 In CFI-mode 3: SC0x control ports 0 and 4; SC1x control ports 1 and 5;
 SC2x control ports 2 and 6; SC3x control ports 3 and 7*

Detailed Register Description

4.2.3 Memory Access Registers

4.2.3.1 Memory Access Control Register (MACR)

Access in demultiplexed μ P-interface mode: read/write address: 0_H
 OMDR:RBS = 0
 Access in multiplexed μ P-interface mode: read/write address: 00_H
 Reset value: xx_H

| | | | | | | | |
|-------|------|------|------|--------------|------|------|------|
| bit 7 | | | | bit 0 | | | |
| RWS | MOC3 | MOC2 | MOC1 | MOC0 CMC3 | CMC2 | CMC1 | CMC0 |

With the MACR the μ P selects the type of memory (CM or DM), the type of field (data or code) and the access mode (read or write) of the register access. When writing to the control memory code field, MACR also contains the 4 bit code (CMC3..0) defining the function of the addressed CFI time slot.

RWS Read/Write Select.
 0...write operation on control or data memories
 1...read operation on control or data memories

MOC3..0 Memory Operation Code.

CMC3..0 Control Memory Code.
 These bits determine the type and destination of the memory operation as shown below.

Note: Prior to a new access to any memory location (i.e. writing to MACR) the STAR:MAC bit must be polled for "0".

Detailed Register Description

- 1. Writing data to the upstream DM data field (e.g. PCM idle code).
Reading data from the upstream or downstream DM data field.**

MACR:

| | | | | | | | |
|-----|------|------|------|------|---|---|---|
| RWS | MOC3 | MOC2 | MOC1 | MOC0 | 0 | 0 | 0 |
|-----|------|------|------|------|---|---|---|

MOC3..0 defines the bandwidth and the position of the subchannel as shown below:

| MOC3..0 | Transferred Bits | Channel Bandwidth |
|---------|------------------|-------------------|
| 0000 | – | – |
| 0001 | bits 7..0 | 64 kbit/s |
| 0011 | bits 7..4 | 32 kbit/s |
| 0010 | bits 3..0 | 32 kbit/s |
| 0111 | bits 7..6 | 16 kbit/s |
| 0110 | bits 5..4 | 16 kbit/s |
| 0101 | bits 3..2 | 16 kbit/s |
| 0100 | bits 1..0 | 16 kbit/s |

Note: When reading a DM data field location, all 8 bits are read regardless of the bandwidth selected by the MOC bits.

- 2. Writing to the upstream DM code (tristate) field.
Control-reading the upstream DM code (tristate).**

MACR:

| | | | | | | | |
|-----|------|------|------|------|---|---|---|
| RWS | MOC3 | MOC2 | MOC1 | MOC0 | 0 | 0 | 0 |
|-----|------|------|------|------|---|---|---|

MOC = 1100 Read/write tristate info from/to single PCM time slot

MOC = 1101 Write tristate info to all PCM time slots

Note: The tristate field is exchanged with the 4 least significant bits (LSBs) of the MADR.

- 3. Writing data to the upstream or downstream CM data field (e.g. signaling code).
Reading data from the upstream or downstream CM data field.**

MACR:

| | | | | | | | |
|-----|---|---|---|---|---|---|---|
| RWS | 1 | 0 | 0 | 1 | 0 | 0 | 0 |
|-----|---|---|---|---|---|---|---|

Detailed Register Description

4. Writing data to the upstream or downstream CM data and code field (e.g. switching a CFI to/from PCM connection).

MACR:

| | | | | | | | |
|---|---|---|---|------|------|------|------|
| 0 | 1 | 1 | 1 | CMC3 | CMC2 | CMC1 | CMC0 |
|---|---|---|---|------|------|------|------|

The 4-bit code field of the control memory (CM) defines the functionality of a CFI time slot and thus the meaning of the corresponding data field. This 4-bit code, written to the MACR:CMC3..0 bit positions, will be transferred to the CM code field. The 8-bit MADR value is at the same time transferred to the CM data field. There are codes for switching applications, pre-processed applications and for direct μ P access applications, as shown below:

a) Switching Applications

| | |
|------------|---|
| CMC = 0000 | Unassigned channel (e.g. cancelling an assigned channel) |
| CMC = 0001 | Bandwidth 64 kbit/s PCM time slot bits transferred: 7..0 |
| CMC = 0010 | Bandwidth 32 kbit/s PCM time slot bits transferred: 3..0 |
| CMC = 0011 | Bandwidth 32 kbit/s PCM time slot bits transferred: 7..4 |
| CMC = 0100 | Bandwidth 16 kbit/s PCM time slot bits transferred: 1..0 |
| CMC = 0101 | Bandwidth 16 kbit/s PCM time slot bits transferred: 3..2 |
| CMC = 0110 | Bandwidth 16 kbit/s PCM time slot bits transferred: 5..4 |
| CMC = 0111 | Bandwidth 16 kbit/s PCM time slot bits transferred: 7..6 |

Note: The corresponding CFI time slot bits to be transferred are chosen in the CSCR-register.

Detailed Register Description

b) Pre-processed Applications

Downstream:

| Application | Even CM Address | Odd CM Address |
|-----------------------------------|-----------------|---|
| Decentral D channel handling | CMC = 1000 | CMC = 1011 |
| Central D channel handling | CMC = 1010 | CMC = PCM code for a 2-bit subtime slot |
| 6-bit Signaling (e.g. analog IOM) | CMC = 1010 | CMC = 1011 |
| 8-bit Signaling (e.g. SLD) | CMC = 1010 | CMC = 1011 |

Upstream:

| Application | Even CM Address | Odd CM Address |
|-----------------------------------|-----------------|---|
| Decentral D channel handling | CMC = 1000 | CMC = 0000 |
| Central D channel handling | CMC = 1000 | CMC = PCM code for a 2-bit subtime slot |
| 6-bit Signaling (e.g. analog IOM) | CMC = 1010 | CMC = 1010 |
| 8-bit Signaling (e.g. SLD) | CMC = 1011 | CMC = 1011 |

c) μ P-access Applications

MACR:

| | | | | | | | |
|---|---|---|---|---|---|---|---|
| 0 | 1 | 1 | 1 | 1 | 0 | 0 | 1 |
|---|---|---|---|---|---|---|---|

Setting CMC = 1001, initializes the corresponding CFI time slot to be accessed by the μ P. Concurrently, the datum in MADR is written (as 8-bit CFI-idle code) to the CM data field. The content of the CM data field is directly exchanged with the corresponding time slot.

Note that once the CM code field has been initialized, the CM data field can be written and read as described in **subsection 3**.

5. Control-reading the upstream or downstream CM code.

MACR:

| | | | | | | | |
|---|---|---|---|---|---|---|---|
| 1 | 1 | 1 | 1 | 0 | 0 | 0 | 0 |
|---|---|---|---|---|---|---|---|

The CM code can then be read out of the 4 LSBs of the MADR register.

Detailed Register Description

4.2.3.2 Memory Access Address Register (MAAR)

Access in demultiplexed μ P-interface mode: read/write address: 1_H
 OMDR:RBS = 0
 Access in multiplexed μ P-interface mode: read/write address: 02_H
 Reset value: xx_H

| | | | | | | | |
|-------------|-----|-----|-----|-----|-----|-----|-------|
| bit 7 | | | | | | | bit 0 |
| U/\bar{D} | MA6 | MA5 | MA4 | MA3 | MA2 | MA1 | MA0 |

The Memory Access Address Register MAAR specifies the address of the memory access. This address encodes a CFI time slot for control memory (CM) and a PCM time slot for data memory (DM) accesses. Bit 7 of MAAR (U/\bar{D} bit) selects between upstream and downstream memory blocks. Bits MA6..0 encode the CFI or PCM port and time slot number as in the following tables:

Table 3
Time Slot Encoding for Data Memory Accesses

| Data Memory Address | | |
|---------------------|--|---|
| PCM-mode 0 | bit U/\bar{D} bits MA6..MA3, MA0 bits MA2..MA1 | Direction selection Time slot selection Logical PCM port number |
| PCM-mode 1,3 | bit U/\bar{D} bits MA6..MA3, MA1, MA0 bit MA2 | Direction selection Time slot selection Logical PCM port number |
| PCM-mode 2 | bit U/\bar{D} bits MA6..MA0 | Direction selection Time slot selection |

Detailed Register Description**4.2.4 Synchronous Transfer Registers****4.2.4.1 Synchronous Transfer Data Register (STDA)**

Access in demultiplexed μ P-interface mode: read/write address: 3_H
 OMDR:RBS = 0
 Access in multiplexed μ P-interface mode: read/write address: 06_H
 Reset value: xx_H

| | | | | | | | |
|-------|-------|-------|-------|-------|-------|-------|-------|
| bit 7 | | | | | | | bit 0 |
| MTDA7 | MTDA6 | MTDA5 | MTDA4 | MTDA3 | MTDA2 | MTDA1 | MTDA0 |

The STDA register buffers the data transferred over the synchronous transfer channel A. MTDA7 to MTDA0 hold the bits 7 to 0 of the respective time slot. MTDA7 (MSB) is the bit transmitted/received first, MTDA0 (LSB) the bit transmitted/received last over the serial interface.

4.2.4.2 Synchronous Transfer Data Register B (STDB)

Access in demultiplexed μ P-interface mode: read/write address: 4_H
 OMDR:RBS = 0
 Access in multiplexed μ P-interface mode: read/write address: 08_H
 Reset value: xx_H

| | | | | | | | |
|-------|-------|-------|-------|-------|-------|-------|-------|
| bit 7 | | | | | | | bit 0 |
| MTDB7 | MTDB6 | MTDB5 | MTDB4 | MTDB3 | MTDB2 | MTDB1 | MTDB0 |

The STDB register buffers the data transferred over the synchronous transfer channel B. MTDB7 to MTDB0 hold the bits 7 to 0 of the respective time slot. MTDB7 (MSB) is the bit transmitted/received first, MTDB0 (LSB) the bit transmitted/received last over the serial interface.

Detailed Register Description

4.2.4.3 Synchronous Transfer Receive Address Register A (SARA)

Access in demultiplexed μ P-interface mode: read/write address: 5_H
 OMDR:RBS = 0
 Access in multiplexed μ P-interface mode: read/write address: $0A_H$
 Reset value: xx_H

| | | | | | | | |
|-------|-------|-------|-------|-------|-------|-------|-------|
| bit 7 | | | | | | | bit 0 |
| ISRA | MTRA6 | MTRA5 | MTRA4 | MTRA3 | MTRA2 | MTRA1 | MTRA0 |

The SARA register specifies for synchronous transfer channel A from which input interface, port and time slot the serial data is extracted. This data can then be read from the STDA register.

ISRA Interface Select Receive for channel A.

0... selects the PCM interface as the input interface for synchronous channel A.

1... selects the CFI interface as the input interface for synchronous channel A.

MTRA6..0 μ P Transfer Receive Address for channel A; selects the port and time slot number at the interface selected by ISRA according to **tables 3** and **4**:
 MTRA6..0 = MA6..0.

Detailed Register Description

4.2.4.4 Synchronous Transfer Receive Address Register B (SARB)

Access in demultiplexed μ P-interface mode: read/write address: 6_H
OMDR:RBS = 0
Access in multiplexed μ P-interface mode: read/write address: $0C_H$
Reset value: xx_H

| | | | | | | | |
|-------|-------|-------|-------|-------|-------|-------|-------|
| bit 7 | | | | | | | bit 0 |
| ISRB | MTRB6 | MTRB5 | MTRB4 | MTRB3 | MTRB2 | MTRB1 | MTRB0 |

The SARB register specifies for synchronous transfer channel B from which input interface, port and time slot the serial data is extracted. This data can then be read from the STDB register.

ISRB Interface Select Receive for channel B.
0... selects the PCM interface as the input interface for synchronous channel B.
1... selects the CFI-interface as the input interface for synchronous channel B.

MTRB6..0 μ P-Transfer Receive Address for channel B; selects the port and time slot number at the interface selected by ISRB according to **tables 3** and **4**:
MTRB6..0 = MA6..0.

4.2.4.5 Synchronous Transfer Transmit Address Register A (SAXA)

Access in demultiplexed μ P-interface mode: read/write address: 7_H
OMDR:RBS = 0
Access in multiplexed μ P-interface mode: read/write address: $0E_H$
Reset value: xx_H

| | | | | | | | |
|-------|-------|-------|-------|-------|-------|-------|-------|
| bit 7 | | | | | | | bit 0 |
| ISXA | MTXA6 | MTXA5 | MTXA4 | MTXA3 | MTXA2 | MTXA1 | MTXA0 |

The SAXA register specifies for synchronous transfer channel A to which output interface, port and time slot the serial data contained in the STDA register is sent.

ISXA Interface Select Transmit for channel A.
0... selects the PCM interface as the output interface for synchronous channel A.
1... selects the CFI interface as the output interface for synchronous channel A.

MTXA6..0 μ P-Transfer Transmit Address for channel A; selects the port and time slot number at the interface selected by ISXA according to **tables 3** and **4**:
MTXA6..0 = MA6..0.

Detailed Register Description

4.2.4.6 Synchronous Transfer Transmit Address Register B (SAXB)

Access in demultiplexed μ P-interface mode: read/write address: 8_H
OMDR:RBS = 0

Access in multiplexed μ P-interface mode: read/write address: 10_H

Reset value: xx_H

| | | | | | | | |
|-------|-------|-------|-------|-------|-------|-------|-------|
| bit 7 | | | | | | | bit 0 |
| ISXB | MTXB6 | MTXB5 | MTXB4 | MTXB3 | MTXB2 | MTXB1 | MTXB0 |

The SAXB register specifies for synchronous transfer channel B to which output interface, port and time slot the serial data contained in the STDB register is sent.

ISXB Interface Select Transmit for channel B.
0... selects the PCM interface as the output interface for synchronous channel B.
1... selects the CFI interface as the output interface for synchronous channel B.

MTXB6..0 μ P-Transfer Transmit Address for channel B; selects the port and time slot number at the interface selected by ISXB according to **tables 3** and **4**:
MTXB6..0 = MA6..0.

4.2.4.7 Synchronous Transfer Control Register (STCR)

Access in demultiplexed μ P-interface mode: read/write address: 09_H
OMDR:RBS = 0

Access in multiplexed μ P-interface mode: read/write address: 12_H

Reset value: $00xxxxxx_B$

| | | | | | | | |
|-------|-----|------|------|------|------|------|-------|
| bit 7 | | | | | | | bit 0 |
| TBE | TAE | CTB2 | CTB1 | CTB0 | CTA2 | CTA1 | CTA0 |

The STCR register bits are used to enable or disable the synchronous transfer utility and to determine the sub time slot bandwidth and position if a PCM interface time slot is involved.

TAE, TBE Transfer Channel A (B) Enable.
1... enables the μ P transfer of the corresponding channel.
0... disables the μ P transfer of the corresponding channel.

Detailed Register Description

CTA2..0 Channel Type A (B); these bits determine the bandwidth of the channel and
CTB2..0 the position of the relevant bits in the time slot according to the table below.
Note: Note that if a CFI time slot is selected as receive or transmit time slot of the synchronous transfer, the 64-kbit/s bandwidth must be selected (CT#2..CT#0 = 001).

| CT#2 | CT#1 | CT#0 | Bandwidth | Transferred Bits |
|------|------|------|-------------|------------------|
| 0 | 0 | 0 | not allowed | – |
| 0 | 0 | 1 | 64 kbit/s | bits 7..0 |
| 0 | 1 | 0 | 32 kbit/s | bits 3..0 |
| 0 | 1 | 1 | 32 kbit/s | bits 7..4 |
| 1 | 0 | 0 | 16 kbit/s | bits 1..0 |
| 1 | 0 | 1 | 16 kbit/s | bits 3..2 |
| 1 | 1 | 0 | 16 kbit/s | bits 5..4 |
| 1 | 1 | 1 | 16 kbit/s | bits 7..6 |

4.2.5 Monitor/Feature Control Registers

4.2.5.1 MF-Channel Active Indication Register (MFAIR)

Access in demultiplexed μ P-interface mode: read address: A_H
 OMDR:RBS = 0
 Access in multiplexed μ P-interface mode: read address: 14_H
 Reset value: 00_H

| | | | | | | | |
|-------|-------|------|------|------|------|------|------|
| bit 7 | bit 0 | | | | | | |
| 0 | SO | SAD5 | SAD4 | SAD3 | SAD2 | SAD1 | SAD0 |

This register is only used in IOM-2 applications (active handshake protocol) in order to identify active monitor channels when the “Search for active monitor channels” command (CMDR:MFSO) has been executed.

SO MF Channel Search On.
 0...the search is completed.
 1...the EPIC is still busy looking for an active channel.

SAD5..0 Subscriber Address 5..0; after an ISTA:MAC interrupt these bits point to the port and time slot where an active channel has been found. The coding is identical to MFSAR:SAD5..SAD0.

Detailed Register Description

4.2.5.2 MF-Channel Subscriber Address Register (MFSAR)

Access in demultiplexed μ P-interface mode: write address: A_H
 OMDR:RBS = 0
 Access in multiplexed μ P-interface mode: write address: 14_H
 Reset value: xx_H

| | | | | | | | | |
|-------|-------|------|------|------|------|------|------|-------|
| bit 7 | | | | | | | | bit 0 |
| MFTC1 | MFTC0 | SAD5 | SAD4 | SAD3 | SAD2 | SAD1 | SAD0 | |

The exchange of monitor data normally takes place with only one subscriber circuit at a time. This register serves to point the MF handler to that particular CFI time slot.

MFTC1..0 MF Channel Transfer Control 1..0; these bits, in addition to CMDR:MFT1,0 and OMDR:MFPS control the MF channel transfer as indicated in **table 5**.

SAD5..0 Subscriber address 5..0; these bits define the addressed subscriber. The CFI time slot encoding is similar to the one used for Control Memory accesses using the MAAR register (**tables 3 and 4**):

CFI time slot encoding of MFSAR derived from MAAR:

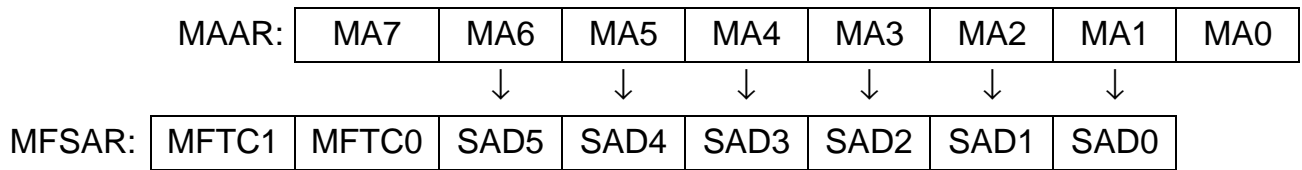

MAAR:MA7 selects between upstream and downstream CM blocks. This information is not required since the transfer direction is defined by CMDR (transmit or receive).

MAAR:MA0 selects between even and odd time slots. This information is also not required since MF channels are always located on even time slots.

Detailed Register Description

4.2.5.3 Monitor/Feature Control Channel FIFO (MFFIFO)

Access in demultiplexed μ P-interface mode: read/write address: B_H
OMDR:RBS = 0

Access in multiplexed μ P-interface mode: read/write address: 16_H

Reset value: empty

| | | | | | | | |
|-------|------|------|------|------|------|------|-------|
| bit 7 | | | | | | | bit 0 |
| MFD7 | MFD6 | MFD5 | MFD4 | MFD3 | MFD2 | MFD1 | MFD0 |

The 16-byte bi-directional MFFIFO provides intermediate storage for data bytes to be transmitted or received over the monitor or feature control channel.

MFD7..0 MF Data bits 7..0; MFD7 (MSB) is the first bit to be sent over the serial CFI, MFD0 (LSB) the last.

Note: The byte n + 1 of an n-byte transmit message in monitor channel is not defined.

4.2.6 Status/Control Registers

4.2.6.1 Signaling FIFO (CIFIFO)

Access in demultiplexed μ P-interface mode: read address: C_H
OMDR:RBS = 0

Access in multiplexed μ P-interface mode: read address: 18_H

Reset value: 0xxxxxxx_B

| | | | | | | | |
|-------|------|------|------|------|------|------|-------|
| bit 7 | | | | | | | bit 0 |
| SBV | SAD6 | SAD5 | SAD4 | SAD3 | SAD2 | SAD1 | SAD0 |

The 9 byte deep CIFIFO stores the addresses of CFI time slots in which a C/I and/or a SIG value change has taken place. This address information can then be used to read the actual C/I or SIG value from the control memory.

SBV Signaling Byte Valid.

0... the SAD6..0 bits are invalid.

1... the SAD6..0 bits indicate a valid subscriber address. The polarity of SBV is chosen such that the whole 8 bits of the CIFIFO can be copied to the MAAR register in order to read the upstream C/I or SIG value from the control memory.

SAD6..0 Subscriber Address bits 6..0; The CM address which corresponds to the CFI time slot where a C/I or SIG value change has taken place is encoded in these bits. For C/I channels SAD6..0 point to an even CM-address (C/I value), for SIG channels SAD6..0 point to an odd CM-address (stable SIG value).

Detailed Register Description

4.2.6.2 Timer Register (TIMR)

Access in demultiplexed μ P-interface mode: write address: C_H
OMDR:RBS = 0

Access in multiplexed μ P-interface mode: write address: 18_H

Reset value: 00_H

| | | | | | | | |
|-------|-------|-------|-------|-------|-------|-------|-------|
| bit 7 | | | | | | | bit 0 |
| SSR | TVAL6 | TVAL5 | TVAL4 | TVAL3 | TVAL2 | TVAL2 | TVAL0 |

The EPIC timer can be used for 3 different purposes: timer interrupt generation (ISTA:TIG), FSC multiframe generation (CMD2:FC2..0 = 111) and last look period generation.

SSR Signaling Sampling Rate.

0... the last look period is defined by TVAL6..0.

1... the last look period is fixed to 125 μ s.

TVAL6..0 Timer Value bits 6..0; the timer period, equal to $(1+TVAL6..0) \times 250 \mu$ s, is programmed here. It can thus be adjusted within the range of 250 μ s up to 32 ms.

The timer is started as soon as CMDR:ST is set to 1 and stopped by writing the TIMR register or by selecting OMDR:OMS0 = 0.

Detailed Register Description

4.2.6.3 Status Register (STAR)

Access in demultiplexed μ P-interface mode: read address: D_H
OMDR:RBS = 0

Access in multiplexed μ P-interface mode: read address: 1A_H

Reset value: 05_H

| | |
|-------|-------|
| bit 7 | bit 0 |
| MAC | TAC |
| PSS | MFTO |
| MFAB | MFAE |
| MFRW | MFFE |

The status register STAR displays the current state of certain events within the EPIC. The STAR register bits do not generate interrupts and are not modified by reading STAR.

- MAC** Memory Access
0...no memory access is in operation.
1...a memory access is in operation. Hence, the memory access registers may not be used.
Note:MAC is also set and reset during synchronous transfers.
- TAC** Timer Active
0...the timer is stopped.
1...the timer is running.
- PSS** PCM Synchronization Status.
1...the PCM interface is synchronized.
0...the PCM interface is not synchronized. There is a mismatch between the PBNR value and the applied clock and framing signals (PDC/PFS) or OMDR:OMS0 = 0.
- MFTO** MF Channel Transfer in Operation.
0...no MF channel transfer is in operation.
1...an MF channel transfer is in operation.
- MFAB** MF Channel Transfer Aborted.
0...the remote receiver did not abort a handshake message transfer.
1...the remote receiver aborted a handshake message transfer.
- MFAE** MFFIFO Access Enable.
0...the MFFIFO may not be accessed.
1...the MFFIFO may be either read or written to.
- MFRW** MFFIFO Read/Write.
0...the MFFIFO is ready to be written to.
1...the MFFIFO may be read.
- MFFE** MFFIFO Empty
0...the MFFIFO is not empty.
1...the MFFIFO is empty.

Detailed Register Description

4.2.6.4 Command Register (CMDR)

Access in demultiplexed μ P-interface mode: write address: D_H
 OMDR:RBS = 0
 Access in multiplexed μ P-interface mode: write address: $1A_H$
 Reset value: 00_H

| | | | | | | | |
|-------|----|-----|-----|------|------|------|-------|
| bit 7 | | | | | | | bit 0 |
| 0 | ST | TIG | CFR | MFT1 | MFT0 | MFSO | MFFR |

Writing a logical 1 to a CMDR register bit starts the respective operation.

- ST** Start Timer.
 0... no action. If the timer shall be stopped, the TIMR register must simply be written with a random value.
 1... starts the timer to run cyclically from 0 to the value programmed in TIMR:TVAL6..0.
- TIG** Timer Interrupt Generation.
 0... setting the TIG bit to logical 0 together with the CMDR:ST bit set to logical 1 disables the interrupt generation.
 1... setting the TIG bit to logical 1 together with CMDR:ST bit set to logical 1 causes the EPIC to generate a periodic interrupt (ISTA:TIN) each time the timer expires.
- CFR** CIFO Reset.
 0... no action.
 1... resets the signaling FIFO within 2 RCL periods, i.e. all entries and the ISTA:SFI bit are cleared.
- MFT1..0** MF channel Transfer Control Bits 1, 0; these bits start the monitor transfer enabling the contents of the MFFIFO to be exchanged with the subscriber circuits as specified in MFSAR. The function of some commands depends furthermore on the selected protocol (OMDR:MFPS). **Table 5** summarizes all available MF commands.
- MFSO** MF channel Search On.
 0... no action.
 1... the EPIC- starts to search for active MF channels. Active channels are characterized by an active MX bit (logical 0) sent by the remote transmitter. If such a channel is found, the corresponding address is stored in MFAIR and an ISTA:MAC-interrupt is generated. The search is stopped when an active MF channel has been found or when OMDR:OMS0 is set to 0.

Detailed Register Description

MFFR MFFIFO Reset.

0... no action

1... resets the MFFIFO and all operations associated with the MF handler (except for the search function) within 2 RCL periods. The MFFIFO is set into the state "MFFIFO empty", write access enabled and any monitor data transfer currently in process will be aborted.

Table 5
Summary of MF-Channel Commands

| Transfer Mode | CMDR: MFT1,MFT0 | MFSAR | Protocol Selection | Application |
|--------------------------------------|--------------------|------------|-----------------------|-------------------|
| Inactive | 00 | xxxxxxx | HS, no HS | Idle state |
| Transmit | 01 | 00 SAD5..0 | HS, no HS | IOM-2, IOM-1, SLD |
| Transmit broadcast | 01 | 01xxxxxx | HS, no HS | IOM-2, IOM-1, SLD |
| Test operation | 01 | 10----- | HS, no HS | IOM-2, IOM-1, SLD |
| Transmit continuous | 11 | 00 SAD5..0 | HS | IOM-2 |
| Transmit + receive same time slot | | | | |
| Any # of bytes | 10 | 00 SAD5..0 | HS | IOM-2 |
| 1 byte expected | 10 | 00 SAD5..0 | no HS | IOM-1 |
| 2 bytes expected | 10 | 01 SAD5..0 | no HS | (IOM-1) |
| 8 bytes expected | 10 | 10 SAD5..0 | no HS | (IOM-1) |
| 16 bytes expected | 10 | 11 SAD5..0 | no HS | (IOM-1) |
| Transmit + receive same line | | | | |
| 1 byte expected | 11 | 00 SAD5..0 | no HS | SLD |
| 2 bytes expected | 11 | 01 SAD5..0 | no HS | SLD |
| 8 bytes expected | 11 | 10 SAD5..0 | no HS | SLD |
| 16 bytes expected | 11 | 11 SAD5..0 | no HS | SLD |

HS: handshake facility enabled (OMDR:MFPS = 1)

no HS: handshake facility disable (OMDR:MFPS = 0)

Detailed Register Description

4.2.6.5 Interrupt Status Register (ISTA)

Access in demultiplexed μ P-interface mode: read address: E_H
 OMDR:RBS = 0
 Access in multiplexed μ P-interface mode: read address: $1C_H$
 Reset value: 00_H

| | | | | | | | |
|-------|-----|------|-----|-----|-----|-----|-------|
| bit 7 | | | | | | | bit 0 |
| TIN | SFI | MFFI | MAC | PFI | PIM | SIN | SOV |

The ISTA register should be read after an interrupt in order to determine the interrupt source.

- TIN** Timer interrupt; a timer interrupt previously requested with CMDR:ST,TIG = 1 has occurred. The TIN bit is reset by reading ISTA. It should be noted that the interrupt generation is periodic, i.e. unless stopped by writing to TIMR, the ISTA:TIN will be generated each time the timer expires.
- SFI** Signaling FIFO Interrupt; this interrupt is generated if there is at least one valid entry in the CIFIFO indicating a change in a C/I or SIG channel. Reading ISTA does not clear the SFI bit. Instead SFI is cleared if the CIFIFO is empty which can be accomplished by reading all valid entries of the CIFIFO or by resetting the CIFIFO by setting CMDR:CFR to 1.
- MFFI** MFFIFO Interrupt; the last MF-channel command (issued by CMDR:MFT1, MFT0) has been executed and the EPIC is ready to accept the next command. Additional information can be read from STAR:MFT0...MFFE. MFFI is reset by reading ISTA.
- MAC** Monitor channel Active interrupt; the EPIC has found an active monitor channel. A new search can be started by reissuing the CMDR:MFSO command. MAC is reset by reading ISTA.
- PFI** PCM Framing Interrupt; the STAR:PSS bit has changed its polarity. To determine whether the PCM-interface is synchronized or not, STAR must be read. The PFI bit is reset by reading ISTA.
- PIM** PCM Input Mismatch; this interrupt is generated immediately after the comparison logic has detected a mismatch between a pair of PCM input lines. The exact reason for the interrupt can be determined by reading the PICM register. Reading ISTA clears the PIM-bit. A new PIM interrupt can only be generated after the PICM register has been read.

Detailed Register Description

SIN Synchronous transfer Interrupt; The SIN interrupt is enabled if at least one synchronous transfer channel (A and/or B) is enabled via the STCR:TAE, TBE bits. The SIN interrupt is generated when the access window for the μ P opens. After the occurrence of the SIN interrupt the μ P can read and/or write the synchronous transfer data registers (STDA, STDB). The SIN bit is reset by reading ISTA.

SOV Synchronous transfer Overflow; The SOV interrupt is generated if the μ P fails to access the data registers (STDA, STDB) within the access window. The SOV bit is reset by reading ISTA.

4.2.6.6 Mask Register (MASK)

Access in demultiplexed μ P-interface mode: write address: E_H
OMDR:RBS = 0

Access in multiplexed μ P-interface mode: write address: 1C_H

Reset value: 00_H

| | | | | | | | |
|-------|-----|------|-----|-------|-----|-----|-----|
| bit 7 | | | | bit 0 | | | |
| TIN | SFI | MFFI | MAC | PFI | PIM | SIN | SOV |

A logical 1 disables the corresponding interrupt as described in the ISTA-register. A masked interrupt is stored internally and reported in ISTA immediately if the mask is released. However, an SFI interrupt is also reported in ISTA if masked. In this case no interrupt is generated. When writing register MASK while ISTA indicates a non masked interrupt \overline{INT} is temporarily set into the inactive state.

Detailed Register Description

4.2.6.7 Operation Mode Register (OMDR)

Access in demultiplexed μ P-interface mode: read/write address: F_H
OMDR:RBS = X

Access in multiplexed μ P-interface mode: read/write address: $1E_H/3E_H$

Reset value: 00_H

| | | | | | | | |
|-------|------|-----|-----|-------|------|-----|-----|
| bit 7 | | | | bit 0 | | | |
| OMS1 | OMS0 | PSB | PTL | COS | MFPS | CSB | RBS |

OMS1..01 Operational Mode Selection; these bits determine the operation mode of the EPIC according to the following table:

| OMS1..0 | Function |
|---------|---|
| 00 | The CM reset mode is used to reset all locations of the control memory code and data fields with a single command within only 256 RCL cycles. A typical application is resetting the CM with the command $MACR = 70_H$ which writes the contents of $MADR (xx_H)$ to all data field locations and the code '0000' (unassigned channel) to all code field locations. A CM reset should be made after each hardware reset. In the CM-reset mode the EPIC does not operate normally i.e. the CFI- and PCM-interfaces are not operational. |
| 10 | The CM initialization mode allows fast programming of the control memory since each memory access takes a maximum of only 2.5 RCL cycles compared to the 9.5 RCL cycles in the normal mode. Accesses are performed on individual addresses specified by MAAR. The initialization of control/signaling channels in IOM or SLD applications can for example be carried out in this mode. In the CM initialization mode the EPIC does also not work normally. |
| 11 | In the normal operation mode the CFI and PCM interfaces are operational. Memory accesses performed on single addresses (specified by MAAR) take 9.5 RCL cycles. An initialization of the complete data memory tristate field takes 1035 RCL cycles. |
| 01 | In test mode the EPIC sustains normal operation. However memory accesses are no longer performed on a specific address defined by MAAR, but on all locations of the selected memory, the contents of MAAR (including the U/\bar{D} bit!) being ignored. A test mode access takes 2057 RCL cycles. |

Detailed Register Description

- PSB** PCM Standby.
- 0...the PCM interface output pins TxD0..3 are set to high impedance and those \overline{TSC} pins that are actually used as tristate control signals are set to logical 1 (inactive).
- 1...the PCM output pins transmit the contents of the upstream data memory or may be set to high impedance via the data memory tristate field.
- PTL** PCM Test Loop.
- 0...the PCM test loop is disabled.
- 1...the PCM test loop is enabled, i.e. the physical transmit pins TxD# are internally connected to the corresponding physical receive pins RxD#, such that data transmitted over TxD# are internally looped back to RxD# and data externally received over RxD# are ignored. The TxD# pins still output the contents of the upstream data memory according to the setting of the tristate field (only modes 0 and 1; mode 1 with AIS bit set).
- COS** CFI Output driver Selection.
- 0...the CFI output drivers are tristate drivers.
- 1...the CFI output drivers are open drain drivers.
- MFPS** Monitor/Feature control channel Protocol Selection.
- 0...handshake facility disabled (SLD and IOM-1 applications)
- 1...handshake facility enabled (IOM-2 applications)
- CSB** CFI Standby.
- 0...the CFI interface output pins DD0..3, DU0..3, DCL and FSC are set to high impedance.
- 1...the CFI output pins are active.
- RBS** Register Bank Selection. Used in demultiplexed data/address modes only.
- 0...to access the registers used during device operation
- 1...to access the registers used during device initialization.

Detailed Register Description

4.2.6.8 Version Number Status Register (VNSR)

Access in demultiplexed μ P-interface mode: read address: D_H
 OMDR:RBS = 1
 Access in multiplexed μ P-interface mode: read address: $3A_H$
 Reset value: $0x_H$

| | | | | | | | |
|-------|---|---|---|-----|-----|-----|-------|
| bit 7 | | | | | | | bit 0 |
| IR | 0 | 0 | 0 | VN3 | VN2 | VN1 | VN0 |

The VNSR register bits do not generate interrupts and are not modified by reading VNSR. The IR and VN3..0 bits are read only bits, the SWRX bit is a write only bit.

IR Initialization Request; this bit is set to logical 1 after an inappropriate clocking or after a power failure. It is reset to logical 0 after a control memory reset command: OMDR:OMS1..0 = 00, MACR = 7X.

VN3..0 Version status Number; these bits display the EPIC-1 chip version as follows

| VN3..0 | Chip Versions |
|--------|---------------------|
| 0000 | A1, A2, A3 (EPIC-1) |
| 0000 | 1.0 (EPIC-S) |

5 Application Hints

5.1 Introduction

5.1.1 IOM[®] and SLD Functions

IOM[®] (ISDN Oriented Modular) Interface

The IOM-2 standard defines an industry standard serial bus for interconnecting telecommunications ICs. The standard covers line card, NT1, and terminal architectures for ISDN, DECT and analog loop applications. The IOM-2 standard is a derivative of the IOM-1 interface formerly designed by Siemens to interconnect layer-1 and layer-2 devices within ISDN terminals and on digital line cards.

The **IOM[®]-1 interface** provides a symmetrical full-duplex communication link, containing user data, control/programming, and status channels for 1 ISDN subscriber, i.e. it provides capacity for 2 B channels at 64 kbit/s and 1 D channel at 16 kbit/s. The IOM-1 channel consists of four 8 bit time slots which are serially transferred within an 8 kHz frame. The first 2 time slots carry the B1 and B2 channels, the third time slot carries an 8 bit monitor channel and the fourth time slot carries the 2 bit D channel, a 4 bit Command/Indication (C/I) channel plus 2 additional control bits (T and E bits). The monitor channel serves to exchange control and status information in a message oriented fashion of one byte per message. The C/I channel carries real-time status information between the line transceiver and the layer-2 device or the line card controller. Status information transmitted over the C/I channel is "static" in the sense that the 4 bit word is repeatedly transmitted, every frame, as long as the status condition that it indicates is valid. The T bit is used by some U layer-1 devices as a transparent channel. The E bit is used in conjunction with the monitor channel to indicate the transfer of a monitor byte to the slave device. The various channels are time-multiplexed over a four wire serial interface. The data transfer rate at the IOM-1 interface is 256 kbit/s, the data is clocked with a double rate clock of 512 kHz (DCL) and the frame is synchronized by an 8 kHz framing signal (FSC).

Because the IOM-1 interface structure can handle only 1 ISDN channel, which is too little for line card applications, the **multiplexed IOM[®]-1 bus** was developed. It multiplexes 8 individual IOM-1 channels into the 8 kHz frame. The data transfer rate is now increased to 2.048 Mbit/s, the data is clocked with a double rate clock of 4.096 MHz (DCL) and the frame is synchronized with an 8 kHz framing signal (FSC). The bit timing and FSC position differs slightly from the 256 kbit/s IOM-1 interface. The IOM channel structure however is identical to the non-multiplexed IOM-1 case.

The **IOM[®]-2 bus standard** is an enhancement of both the IOM-1 and multiplexed IOM-1 standards. Both the line card and terminal portions of the IOM-2 standard utilize the same basic frame and clocking structure, but differ in the number and usage of the individual channels. Data is clocked by a data clock (DCL) that operates at twice the data

Application Hints

rate. Frames are delimited by an 8 kHz frame synchronization signal (FSC). The bit timing and FSC position is identical to the non-multiplexed IOM-1 case.

The line card version of the IOM[®]-2 provides a connection path between line transceivers (ISDN) or codecs (analog), and the line card controller, the EPIC. The line card controller provides the connection to the switch backbone. The IOM-2 bus time-multiplexes data, control, and status information for up to 8 ISDN transceivers or up to 16 codec/filters over a single full-duplex interface.

Figure 22 shows the IOM-2 frame structure for the line card. It consists of 8 individual and independent IOM channels, each having a structure similar to the IOM-1 channel structure. The main difference compared to IOM-1 is the more powerful monitor channel performance. Monitor messages of unlimited length can now be transferred at a variable speed, controlled by a handshake procedure using the MR and MX bits. The C/I channel can have a width of 4 bits for ISDN applications or of 6 bits for analog signaling applications.

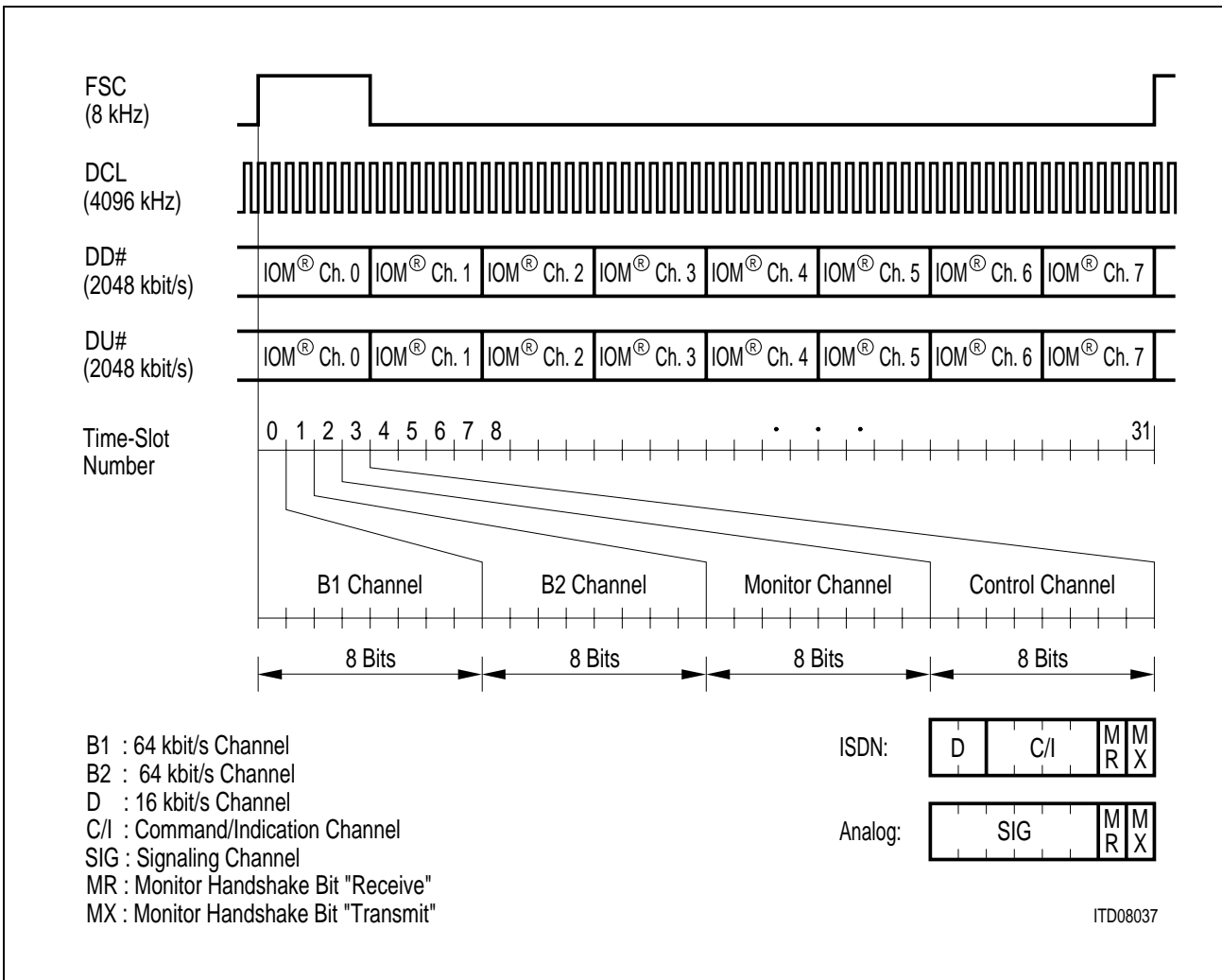

Figure 22
IOM[®]-2 Frame Structure for Line Card Applications

The **terminal version of the IOM[®]-2** is a variation of the line card bus, designed for ISDN terminal and NT1 applications. It consists of three IOM channels, each containing four 8 bit time slots. The resultant data transfer rate is therefore 768 kbit/s and the data is clocked with a 1536 kHz double rate clock (DCL). The IOM channel structure is similar to the line card case. The first channel is dedicated for controlling the layer-1 transceiver (monitor and C/I channels) and passing the user data (B and D channels) to the layer-1 transceiver. The second and third channels are used for communication between a controlling device and devices other than the layer-1 transceiver, or for transferring user data between data processing devices (IC channels). The C/I channel of the third IOM channel is used for TIC bus applications (D and C/I channel arbitration). The TIC bus allows multiple layer-2 devices to individually gain access to the D and C/I channels located in the first IOM channel.

Finally, for NT1 applications, it is also possible to operate the IOM-2 interface at a data rate of 256 kbit/s (1 IOM channel). This is sufficient for the simple back to back connection of layer-1 transceivers in Network Terminator (NT) and Repeater (RP) applications.

The following table summarizes the different operation modes and applications of the IOM-1 and IOM-2 standards (TE = Terminal Equipment, NT = Network Terminator, LT = Line Terminator):

Table 6

| Mode | Applications | Data Rate / Clock Rate |
|-------------------|--------------|--------------------------|
| IOM-1 | TE, NT, LT | 256 kbit/s / 512 kHz |
| Multiplexed IOM-1 | LT | 2.048 Mbit/s / 4.096 MHz |
| IOM-2 | LT | 2.048 Mbit/s / 4.096 MHz |
| IOM-2 | TE, NT | 768 kbit/s / 1.536 MHz |
| IOM-2 | NT | 256 kbit/s / 512 kHz |

The main application of the EPIC is on digital and analog line cards. The EPIC is therefore primarily designed to support the line card modes (2.048 Mbit/s) of the IOM-2 standard. It can however be programmed to support all the above mentioned IOM data rates and C/I and monitor processing schemes. However, it must be assured that the desired PCM to IOM data rate ratio is feasible (refer to **chapter 5.2.2.3**).

SLD (Subscriber Line Data) Interface

The SLD bus is used by the EPIC to interface with the subscriber line devices. A Serial Interface Port (SIP) is used for the transfer of all digital voice and data, feature control and signaling information between the individual subscriber line devices, the PCM highways and the control backplane. The SLD approach provides a common interface for one analog or digital component per line. The EPIC switches the PCM data transparently switched onto the PCM highways.

There are three wires connecting each subscriber line device and the EPIC: two common clock signals shared among all devices, and a unique bidirectional data wire for each of the eight SIP ports. The direction signal (FSC) is an 8 kHz clock output from the EPIC (master) that serves as a frame synch to the subscriber line devices (slave) as well as a transfer indicator. The data is transferred at a 512 kHz data rate, clocked by the subscriber clock (DCL). When FSC is high (first half of the 125 μs SLD frame), four bytes of digital data are transmitted on the SLD bus from the EPIC to the slave (downstream direction). During the second half of the frame when FSC is low, four bytes of data are transferred from the slave back to the EPIC (upstream direction).

Channel B1 and B2 are 64 kbit/s channels reserved for voice and data to be routed to and from the PCM highways. The third and seventh byte are used to transmit and receive control information for programming the slave devices (feature control channel). The last byte in each direction is reserved for signaling data.

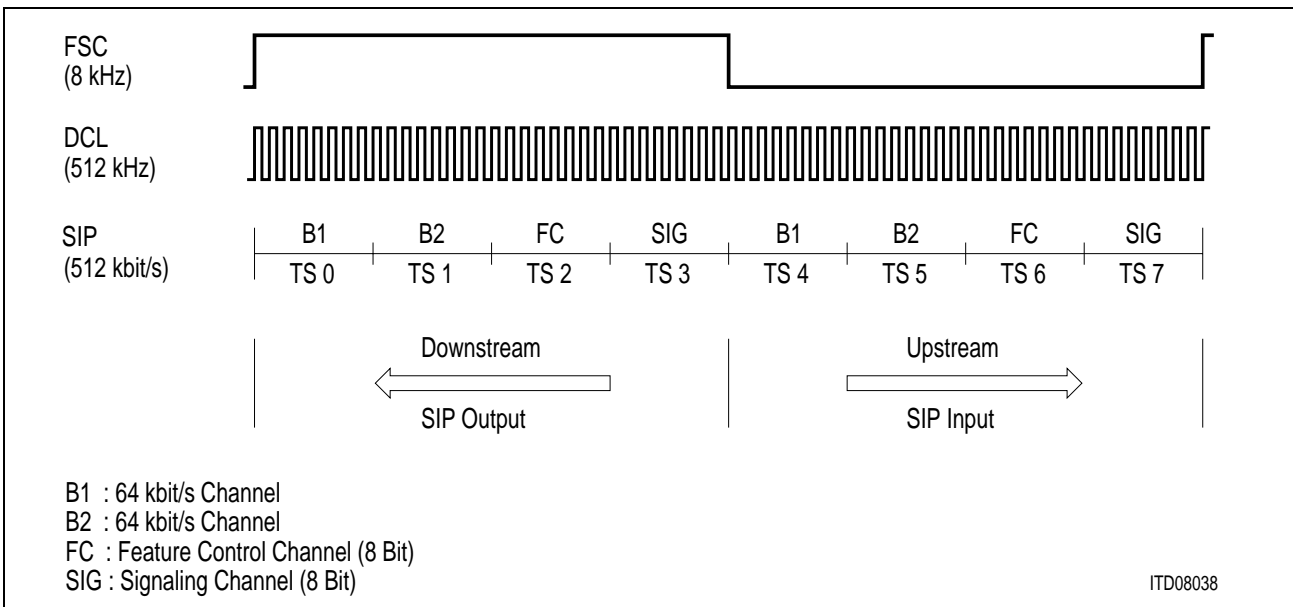

Figure 23
SLD Frame Structure

In contrast to other Siemens telecom devices, the EPIC does not provide an “IOM mode” or an “SLD mode” that can be selected by programming a single “mode bit”. Instead, the EPIC provides a configurable interface (CFI) that can be configured for a great variety of interfaces, including IOM-1, multiplexed IOM-1, IOM-2 and SLD interfaces.

The Characteristics of the Different IOM® and SLD Interfaces can be Divided into Two Groups

- Timing characteristics and
- Handling of special channels (C/I or signaling channel, monitor or feature control channel)

The timing characteristics (data rate, clock rate, bit timing, etc. ...) are programmed in the CFI registers (see **chapter 5.2.2.2**). The CFI data rate, for example, can be selected between 128 kbit/s and 8.192 Mbit/s. This covers the standard IOM and SLD data rates of 256, 512, 768 kbit/s and 2.048 Mbit/s.

The special channels are initialized on a per time slot basis in the control memory (CM). This programming on a per time slot basis allows a dedicated usage of each CFI port and time slot: an application that requires only two IOM-2 compatible layer-1 transceivers will also only occupy 8 CFI time slots (2 IOM channels) for that purpose. The remaining 24 time slots can then be used for general switching applications or for the connection of non IOM-2 compatible devices that require a special μ P handling.

The Special Channels can be Divided into Two Groups

- Monitor/Feature Control channels and
- Control/Signaling channels

The **Monitor/Feature Control handler** can be adjusted to operate according to the

- IOM-1 protocol (up to 1 byte, no handshake), the
- IOM-2 protocol (any number of bytes, handshake using the MR and MX bits) and to the
- SLD protocol (up to 16 bytes in subsequent frames without handshake)

The Monitor/Feature Control handler is a dedicated unit that communicates only with one IOM or SLD channel at a time. An address register selects one out of 64 possible MF channels. A 16 byte bidirectional FIFO (MFFIFO) provides intermediate storage for the data to be sent or received. The message transfer over the MF channel is always half-duplex, i.e. data can either be sent at a time or received at a time.

Note: If the IOM-2 protocol is selected, the actual message length i.e. the number of bytes to be sent or received is unlimited and is not restricted by the MFFIFO size!

If non handshake protocols (IOM-1 and SLD) are used, the EPIC must always be the master of the MF communication. Example: the EPIC programs and reads back the coefficients of a SICOFI (PEB 2060) device.

If the handshake protocol is used (IOM-2), a balanced MF communication is also possible: since the MF handler cannot be pointed to all IOM-2 channels at the same time, the EPIC has implemented a search function that looks for active monitor transmit handshake (MX) bits on all upstream IOM-2 channels. If an active channel is found, the address is stored and an interrupt is generated. The MF handler can then be pointed to

that particular channel and the message transfer can take place.

Example: the EPIC reads an EOC message out of an IEC-Q (PEB 2091) device.

The **Control/Signaling handler** can be adjusted to handle the following types of channels:

- 4 bit C/I channel (IOM-1 and digital IOM-2)
- 6 bit C/I or Signaling channel (analog IOM-2)
- 8 bit Signaling channel (SLD)

In **downstream direction**, the μ P can write the 4, 6 or 8 bit C/I or Signaling value to be transmitted directly to the CFI time slot i.e. to the control memory. This value will then be transmitted repeatedly in each frame until a new value is loaded.

If the 4 bit C/I channel option is selected, the two D channel bits can either be tristated by the EPIC (decentral D channel handling scheme) or they can be switched transparently from any 2 bit subtime slot position at the PCM interface (central D channel handling scheme).

In **upstream direction**, the μ P can read the received 4, 6, or 8 bit C/I or Signaling value directly from the CFI time slot i.e. from the control memory. In addition the Control/Signaling handler checks all received C/I and Signaling channels for changes. Upon a change:

- an interrupt is generated,
- the address of the involved CFI time slot is stored in a 9 byte FIFO (CIFIFO) and
- the new value is stored in the control memory.

The CIFIFO serves to buffer the address information in order to increase the μ P latency time.

The change detection mechanism is based on a single last look procedure for 4 bit C/I channels and on a double last look procedure for 6 and 8 bit C/I or Signaling channels. The single last look period is fixed to 125 μ s, whereas the double last look period is programmable from 125 μ s to 32 ms. The last look period is programmed using the EPIC timer.

With the single last look procedure, each C/I value change immediately leads to a valid change and thus to an interrupt.

With the double last look procedure, a C/I or Signaling value change must be detected two times at the sampling points of the last look interval before a valid change is recognized and an interrupt is generated.

If the 4 bit C/I channel option is selected, the two D channel bits can either be ignored by the EPIC (decentral D channel handling scheme) or they can be switched transparently to any 2 bit subtime slot position at the PCM interface (central D channel handling scheme).

5.2 Configuration of Interfaces

5.2.1 PCM Interface Configuration

5.2.1.1 PCM Interface Signals

The PCM interface signals are summarized in **table 7**.

Table 7

| Pin No. | Symbol | I: Input O: Output | Function |
|---------|-------------------|-----------------------|--|
| 9 | TxD0 | O | Transmit PCM interface data: serial data is sent at standard TTL or CMOS levels (tristate drivers). These pins can be set to high impedance with a 2 bit resolution. |
| 11 | TxD1 | O | |
| 13 | TxD2 | O | |
| 15 | TxD3 | O | |
| 8 | $\overline{TSC0}$ | O | Tristate control signals for the PCM transmit lines. These signals are low when the corresponding TxD# outputs are valid. |
| 10 | $\overline{TSC1}$ | O | |
| 12 | $\overline{TSC2}$ | O | |
| 14 | $\overline{TSC3}$ | O | |
| 6 | RxD0 | I | Receive PCM interface data: serial data is received at standard TTL or CMOS levels. |
| 5 | RxD1 | I | |
| 4 | RxD2 | I | |
| 3 | RxD3 | I | |
| 16 | PFS | I | PCM interface frame synchronization signal. |
| 17 | PDC | I | PCM interface data clock, single or double data rate. |

5.2.1.2 PCM Interface Registers

The characteristics at the PCM interface (timing, modes of operation, etc. ...) are programmed in the 4 PCM interface registers and in the Operation Mode Register OMDR. The function of each bit is described in **chapter 5.2.1.3**. For addresses, refer to **chapter 4.1**.

PCM Mode Register

read/write

reset value:

00_H

bit 7

bit 0

PMOD

| | | | | | | | |
|------|------|-----|-----|------|------|------|------|
| PMD1 | PMD0 | PCR | PSM | AIS1 | AIS0 | AIC1 | AIC0 |
|------|------|-----|-----|------|------|------|------|

Application Hints

PCM Bit Number Register read/write reset value: FF_H

| | | | | | | | | |
|------|-------|------|------|------|------|------|------|-------|
| | bit 7 | | | | | | | bit 0 |
| PBNR | BNF7 | BNF6 | BNF5 | BNF4 | BNF3 | BNF2 | BNF1 | BNF0 |

PCM Offset Downstream Register read/write reset value: 00_H

| | | | | | | | | |
|------|-------|------|------|------|------|------|------|-------|
| | bit 7 | | | | | | | bit 0 |
| POFD | OFD9 | OFD8 | OFD7 | OFD6 | OFD5 | OFD4 | OFD3 | OFD2 |

PCM Offset Upstream Register read/write reset value: 00_H

| | | | | | | | | |
|------|-------|------|------|------|------|------|------|-------|
| | bit 7 | | | | | | | bit 0 |
| POFU | OFU9 | OFU8 | OFU7 | OFU6 | OFU5 | OFU4 | OFU3 | OFU2 |

PCM Clock Shift Register read/write reset value: 00_H

| | | | | | | | | |
|------|-------|------|------|-----|---|------|------|-------|
| | bit 7 | | | | | | | bit 0 |
| PCSR | 0 | OFD1 | OFD0 | DRE | 0 | OFU1 | OFU0 | URE |

Operation Mode Register read/write reset value: 00_H

| | | | | | | | | |
|------|-------|------|------------|------------|-----|------|-----|-------|
| | bit 7 | | | | | | | bit 0 |
| OMDR | OMS1 | OMS0 | PSB | PTL | COS | MFPS | CSB | RBS |

5.2.1.3 PCM Interface Characteristics

In the following the PCM interface characteristics that can be programmed in the PCM interface registers are explained in more detail.

PCM Mode PMOD: PMD1, PMD0

The PCM mode primarily defines the actual number of PCM highways that can be used for switching purposes (logical ports). 1, 2, or 4 logical PCM ports can be selected. Since the channel capacity of the EPIC is constant (128 channels per direction), the PCM mode also influences the maximum possible data rate. In each PCM mode a minimum data rate as well as a minimum data rate stepping are specified.

It should also be noticed that there are some restrictions concerning the PCM to CFI data rate ratio which may affect some applications. These restrictions are described in **chapter 5.2.2.3**.

The table below summarizes the specific characteristics of each PCM mode (DR = PCM data rate):

Table 8

| PMD1 | PMD0 | PCM Mode | Number (Label) of Logical Ports | Data Rate [kbit/s] | | Data Rate Stepping [kbit/s] | PDC Frequency (Clock Rate) |
|------|------|----------|---------------------------------|--------------------|------|-----------------------------|----------------------------|
| | | | | min. | max. | | |
| 0 | 0 | 0 | 4 (0 ... 3) | 256 | 2048 | 256 | DR, 2 × DR |
| 0 | 1 | 1 | 2 (0 ... 1) | 512 | 4096 | 512 | DR, 2 × DR |
| 1 | 0 | 2 | 1 | 1024 | 8192 | 1024 | DR |

*Note: The label is used to specify a PCM port (logical port) when programming a switching function. It should not be confused with the physical port number which refers to actual hardware pins. The relationship between logical and physical port numbers is given in **table 13** and is illustrated in **figure 28**.*

PCM Clock Rate PMOD:PCR

The PCM interface is clocked via the PDC pin. If PCR is set to logical 0, the PDC frequency must be identical to the selected data rate (single clock operation). If PCR is set to logical 1, the PDC frequency must be twice the selected data rate (double clock operation).

Note: In PCM mode 2, only single clock rate operation is allowed.

In PCM mode 0 for example, PCR can be set to 1 to operate at up to four 2.048 MHz PCM highways with a PCM clock of 4.096 MHz.

PCM Bit Number PBNR:BNF7 ... BNF0

The PCM data rate is determined by the clock frequency applied to the PDC pin and the clock rate selected by PMOD:PCR. The number of bits which constitute a PCM frame can be derived from this data rate by dividing by 8000 (8 kHz frame structure).

If the PCM interface is for example operated at 2.048 Mbit/s, the frame would consist of 256 bits or 32 time slots.

Note: There is a mode dependent restriction on the possible number of bits per frame BPF:

Table 9

| PCM Mode | Possible Values for BNF |
|----------|-------------------------|
| 0 | BPF must be modulo 32 |
| 1 | BPF must be modulo 64 |
| 2 | BPF must be modulo 128 |

This number of bits must be programmed to PBNR:BNF7 ... 0 as indicated in **table 10**.

Table 10

| PCM Mode | PBNR:BNF7 ... 0(Hex) |
|----------|------------------------------|
| 0 | $BPF7 \dots 0 = BPF - 1$ |
| 1 | $BPF7 \dots 0 = (BPF - 2)/2$ |
| 2 | $BPF7 \dots 0 = (BPF - 4)/4$ |

The externally applied frame synchronization pulse PFS resets the internal PCM time slot and bit counters. The value programmed to PBNR is internally used to reset the PCM time slot and bit counters so that these counters always count modulo the actual number of bits per frame even in the absence of the external PFS pulse. Additionally, the PFS period is internally checked against the PBNR value. The result of this comparison is displayed in the PCM Synchronization Status bit (STAR:PSS). Also, refer to **chapter 5.8.3**.

Examples

In PCM mode 0 a PCM frame consisting of 32 time slots would require a setting of $PBNR = 32 \times 8 - 1 = 255_D = FF_H$.

In PCM mode 1 a PCM frame consisting of 24 time slots would require a setting of $PBNR = (24 \times 8 - 2)/2 = 95_D = 5F_H$.

In PCM mode 2 a PCM frame consisting of 64 time slots would require a setting of $PBNR = (64 \times 8 - 4)/4 = 127_D = 7F_H$.

PCM Synchronization Mode PMOD:PSM

The PCM interface is synchronized via the PFS signal. A transition from low to high of PFS synchronizes the PCM frame. It should be noted that the rising PFS edge does not directly synchronize the frame, it is instead first internally sampled with the PDC clock:

If PSM is set to logical 0, the PFS signal is sampled with the falling clock edge of PDC, if it is set to logical 1, the PFS signal is sampled with the rising clock edge of PDC.

PSM should be selected such that the PDC signal detects stable low and high levels of the PFS signal, meeting the set-up (T_{FS}) and hold (T_{FH}) times with respect to the programmed PDC clock edge.

In other words, if for example the rising PFS edge has some jitter with respect to the rising PDC edge, the falling PDC edge should be taken for the evaluation.

The high phase of the PFS pulse may be of arbitrary length, however it must be assured that it is sampled low at least once before the next framing pulse.

The relationship between the PFS signal and the beginning of the PCM frame is given in **figure 24** and **figure 25**.

PCM Bit Timing and Bit Shift POFD, POFU, PCSR

The position of the PCM frame can be shifted relative to the framing source PFS in increments of bits by programming the PCM offset bits OFD9 ... 0, OFU9 ... 0 in the POFD, POFU and PCSR. This shifting can be performed separately for up- and downstream directions and by up to a whole frame. Additionally, the polarity of the PDC clock edge used for transmitting and sampling the data can be selected with the URE and DRE bits in the PCSR register.

The time slot structure on the PCM interface is synchronized with the externally applied PFS pulse. The rising edge of PFS, after it has been sampled by the PDC signal, marks the first bit of the PCM frame. This first bit is referenced to as the BND (Bit Number Downstream) of the downstream and the BNU (Bit Number Upstream) of the upstream frame.

If PCSR:URE is set to 1, data is transmitted with the rising edge of PDC, if URE is set to 0, data is transmitted with the next following falling edge of PDC.

If PCSR:DRE is set to 0, data is sampled with the falling edge of PDC, if DRE is set to 1, data is sampled with the next following rising edge of PDC.

The relationship between the PFS, PDC signals and the PCM bit stream on RxD# and TxD# is illustrated in **figure 24** and **figure 25**.

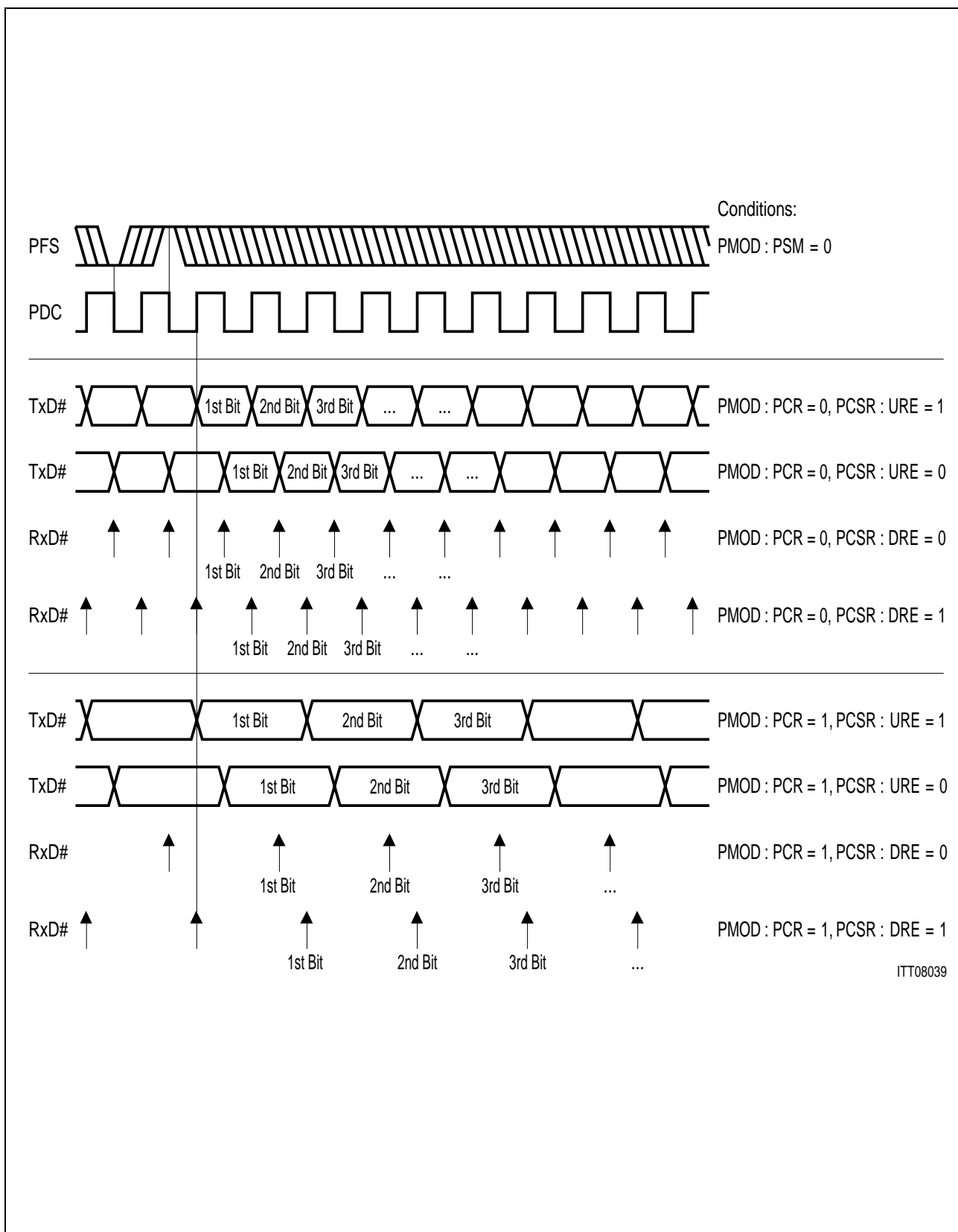

Figure 24
PCM Interface Framing Offset for $PMOD:PSM = 0$

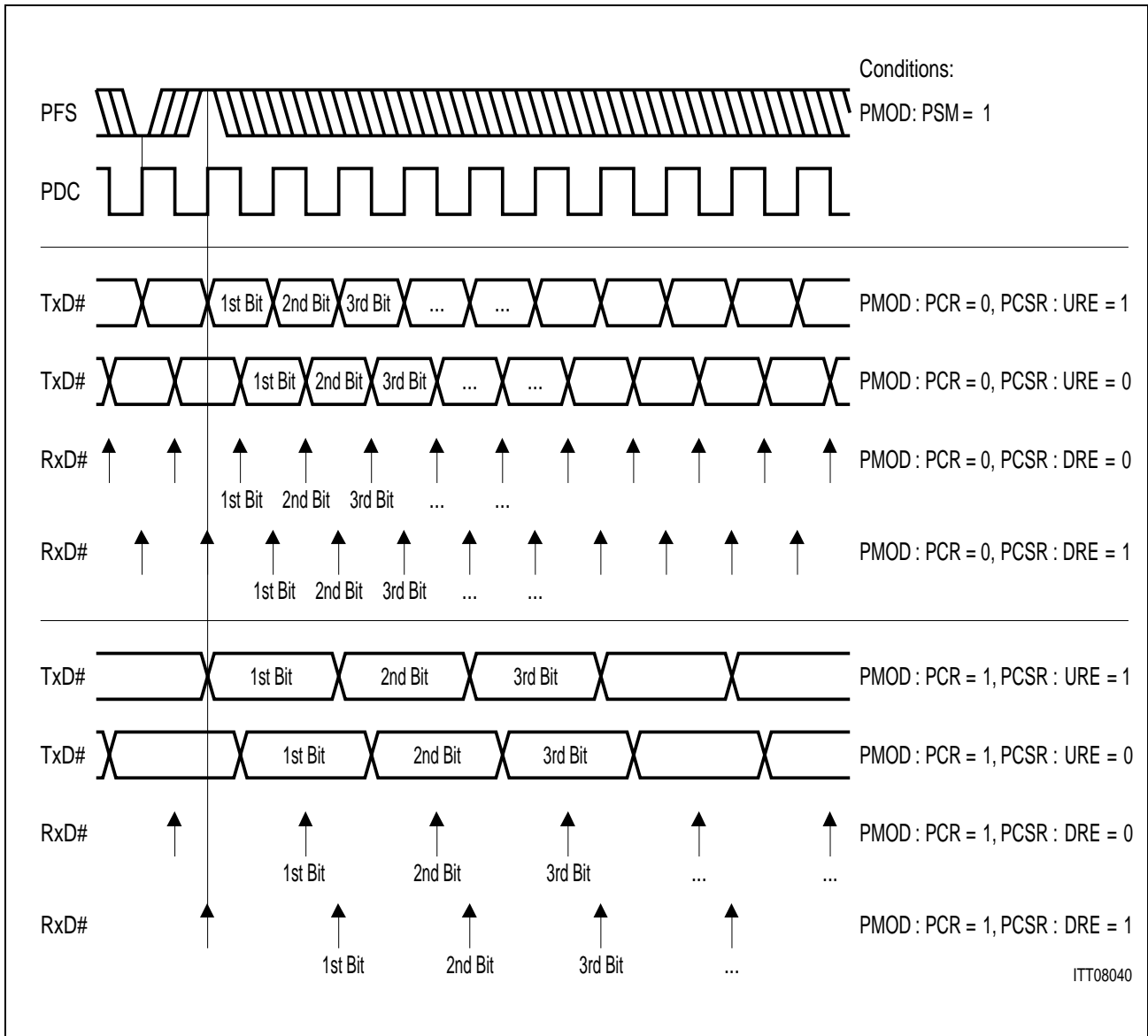

Figure 25
PCM Interface Framing for PMOD:PSM = 1

The formulas given in **table 11** and **table 12** apply for calculating the values to be programmed to the offset registers (OFD, OFU) given the desired bit number (BND, BNU) to be marked. BPF denotes the actual number of bits constituting a frame.

Table 11

| PCM Mode | Offset Downstream, POFD, PCSR | Remarks |
|----------|---|---------------------|
| 0 | $OFD9 \dots 2 = (BND - 17 + BPF)_{\text{mod } BPF}$ | PCSR:OFD1 ... 0 = 0 |
| 1 | $OFD9 \dots 1 = (BND - 33 + BPF)_{\text{mod } BPF}$ | PCSR:OFD0 = 0 |
| 2 | $OFD9 \dots 0 = (BND - 65 + BPF)_{\text{mod } BPF}$ | — |

Table 12

| PCM Mode | Offset Upstream, POFU, PCSR | Remarks |
|----------|--|---------------------|
| 0 | $OFU9 \dots 2 = (BNU + 23)_{\text{mod BPF}}$ | PCSR:OFU1 ... 0 = 0 |
| 1 | $OFU9 \dots 1 = (BNU + 47)_{\text{mod BPF}}$ | PCSR:OFU0 = 0 |
| 2 | $OFU9 \dots 0 = (BNU + 95)_{\text{mod BPF}}$ | – |

Examples

- 1) In PCM mode 0, with a frame consisting of 32 time slots, the following timing relationship between the framing signal and the data signals is required:

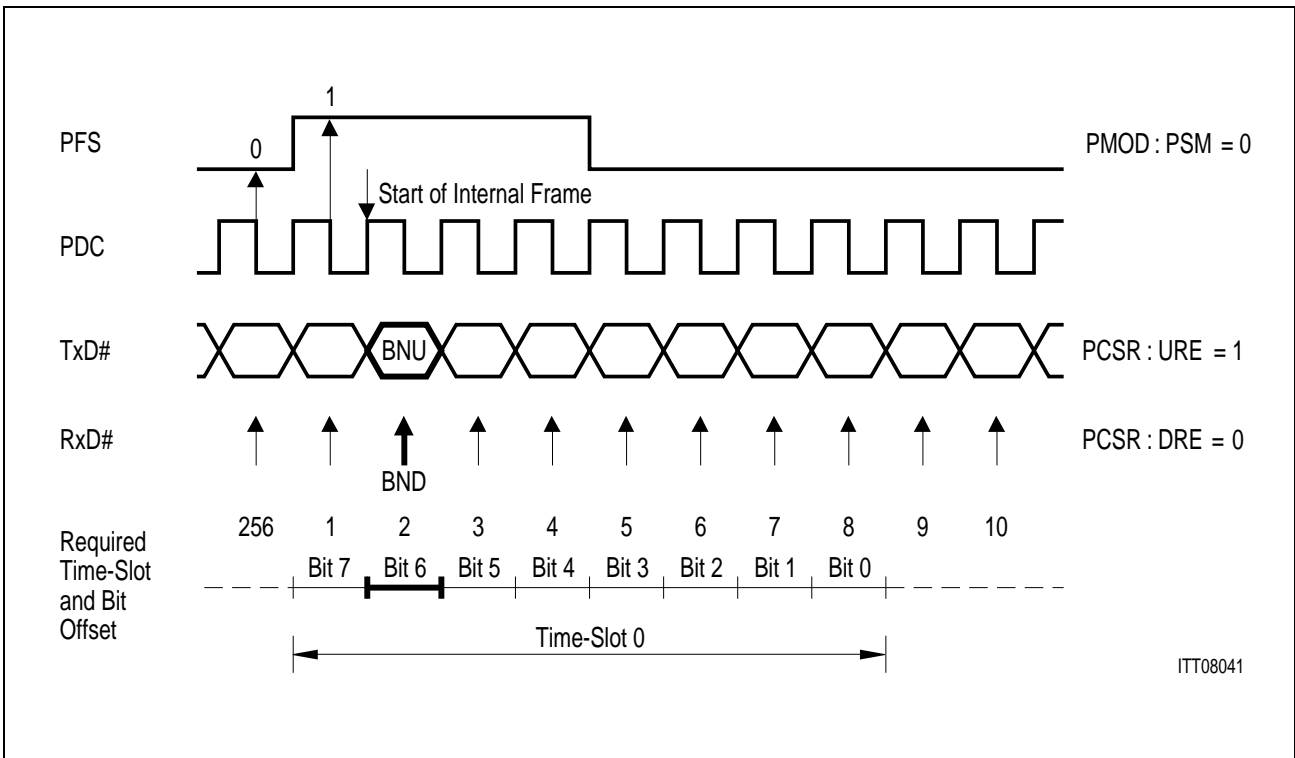

Figure 26
Timing PCM Frame Offset for Example 1

Application Hints

The PCM interface shall be clocked with a PDC having the same frequency as the data rate i.e. 2.048 MHz. Since the rising edge of PFS occurs at the same time as the rising edge of PDC, it is recommended to select the falling PDC edge for sampling the PFS signal (PMOD:PSM0 = 0). In this case the 1st bit of internal framing structure (according to **figure 26**) will represent time slot 0, bit 6 (2nd bit) of the external frame (according to **figure 24**). The values to be programmed to the POFD, POFD and PCSR can now be determined as follows:

With BND = BNU = 2 and BPF = 256:

$$POFD = OFD9 \dots 2 = (BND - 17 + BPF)_{\text{mod } BPF} = (2 - 17 + 256)_{\text{mod } 256} = 241_D = F1_H$$

$$POFU = OFU9 \dots 2 = (BNU + 23)_{\text{mod } BPF} = (2 + 23)_{\text{mod } 256} = 25_D = 19_H$$

With URE = 1 and DRE = 0:

$$PCSR = 01_H$$

- 2) In PCM mode 1, with a frame consisting of 48 time slots, the following timing relationship between the framing signal and the data signals is required:

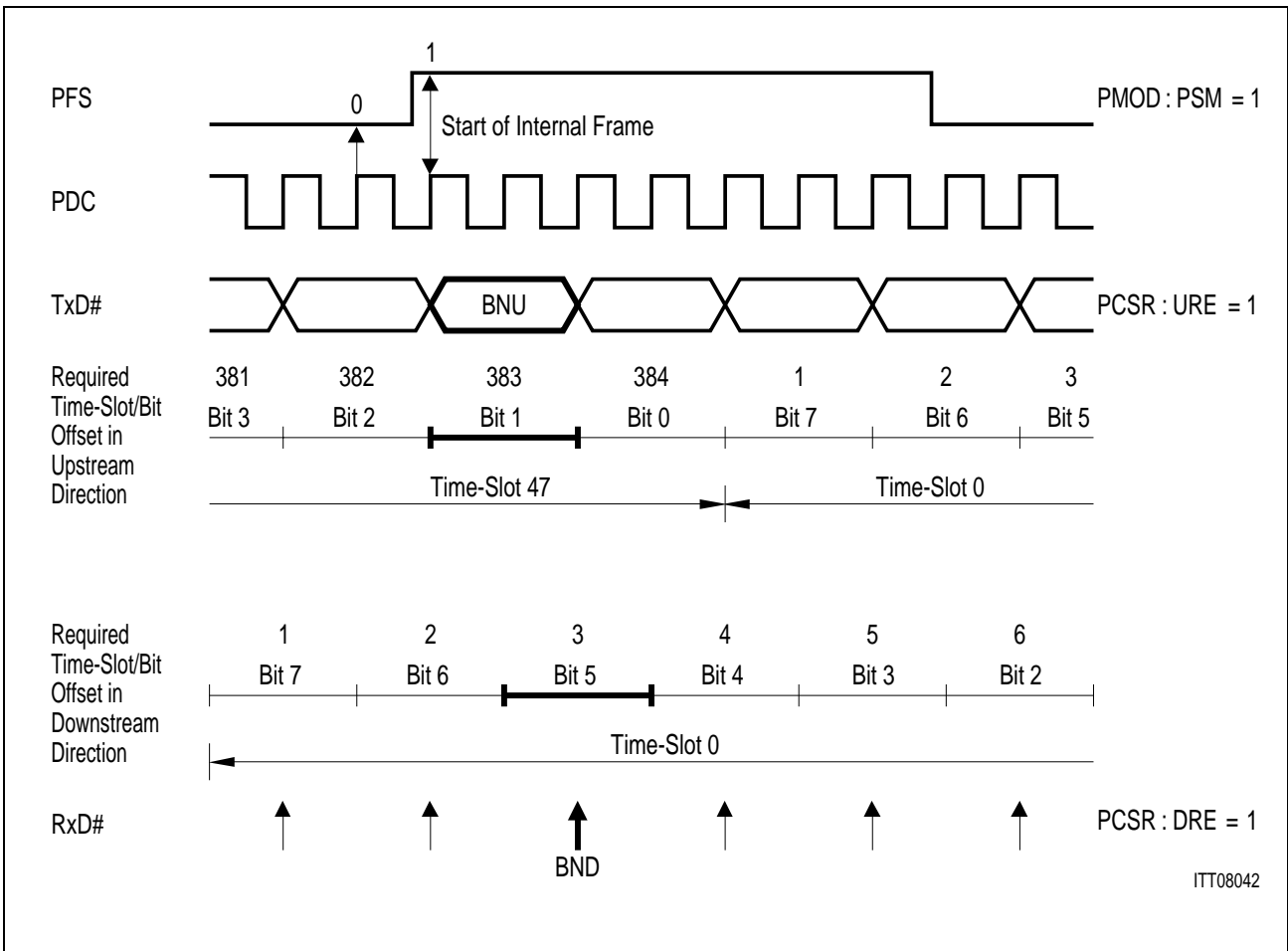

Figure 27
Timing for PCM Frame Offset of Example 2

The PCM interface shall be clocked with a PDC having twice the frequency of the data rate i.e. 6144 kHz. Since the rising edge of PFS occurs a little bit before the rising edge of PDC i.e. the set-up and hold times with respect to the rising PDC are met, it is possible to select the rising PDC edge for sampling the PFS signal (PMOD:PSM = 1). In this case the 1st bit of the internal framing structure (according to **figure 27**) will represent time slot 47, bit 1 (383rd bit) in upstream and time slot 0, bit 5 (3rd bit) in downstream direction of the external frame (according to **figure 25**). The values to be programmed to the POFD, POFD and PCSR can now be determined as follows:

With BND = 3, BNU = 383 and BPF = 384:

$$\text{OFD9} \dots 1 = (\text{BND} - 33 + \text{BPF})_{\text{mod BPF}} = (3 - 33 + 384)_{\text{mod } 384} = 354_{\text{D}} = 1\ 0110\ 0010_{\text{B}}$$

$$\text{OFU9} \dots 1 = (\text{BNU} + 47)_{\text{mod BPF}} = (383 + 47)_{\text{mod } 384} = 46_{\text{D}} = 0001\ 0111\ 0_{\text{B}}$$

$$\text{POFD} = 1011\ 0001_{\text{B}} = \text{B1}_{\text{H}},$$

$$\text{POFU} = 1000\ 1111_{\text{B}} = 17_{\text{H}}$$

With URE = 1 and DRE = 1:

$$\text{PCSR} = 0001\ 0001_{\text{B}} = 11_{\text{H}},$$

PCM Receive Line Selection PMOD:AIS1 ... AIS0

The PCM transmit line of a given logical port (as it is used for programming the switching function) is always assigned to a dedicated physical transmit pin, e.g. in PCM mode 1, pin TxD2 carries the PCM data of logical port 1.

In receive direction however, an assignment between logical and physical ports can be made in PCM modes 1 and 2. This selection is programmed via the Alternative Input Selection bits 1 and 0 (AIS1, AIS0) in the PMOD register.

In PCM mode 0, AIS1 and AIS0 should both be set to 0.

In PCM mode 1, AIS0 selects between receive lines RxD0 and RxD1 for logical port 0 and AIS1 between the receive lines RxD2 and RxD3 for logical port 1.

In PCM mode 2, AIS1 selects between the receive lines RxD2 and RxD3, the setting of AIS0 is don't care.

The state of the AIS# bits is furthermore put out via the $\overline{\text{TSC\#}}$ pins and can thus be used to control external circuits (drivers, relays ...).

Application Hints

Table 13 shows the function taken on by each of the PCM interface pins, depending on the PCM mode and the values programmed to AIS1 and AIS0.

Table 13

| PCM Mode | Port 0 | | | Port 1 | | | Port 2 | | | Port 3 | | |
|----------|----------------|------|------|----------------|--------|------|----------------|--------|--------|----------------|--------|------|
| | RxD0 | TxD0 | TSC0 | RxD1 | TxD1 | TSC1 | RxD2 | TxD2 | TSC2 | RxD3 | TxD3 | TSC3 |
| 0 | IN0 | OUT0 | TSC0 | IN1 | OUT1 | TSC1 | IN2 | OUT2 | TSC2 | IN3 | OUT3 | TSC3 |
| 1 | IN0 for AIS0=1 | OUT0 | TSC0 | IN0 for AIS0=0 | high Z | AIS0 | IN1 for AIS1=1 | OUT1 | TSC1 | IN1 for AIS1=0 | high Z | AIS1 |
| 2 | - | OUT | TSC | - | high Z | AIS0 | IN for AIS1=1 | undef. | undef. | IN for AIS1=0 | high Z | AIS1 |

Figure 28 shows the correlation between physical and logical PCM ports for PCM modes 0, 1, 2, 3:

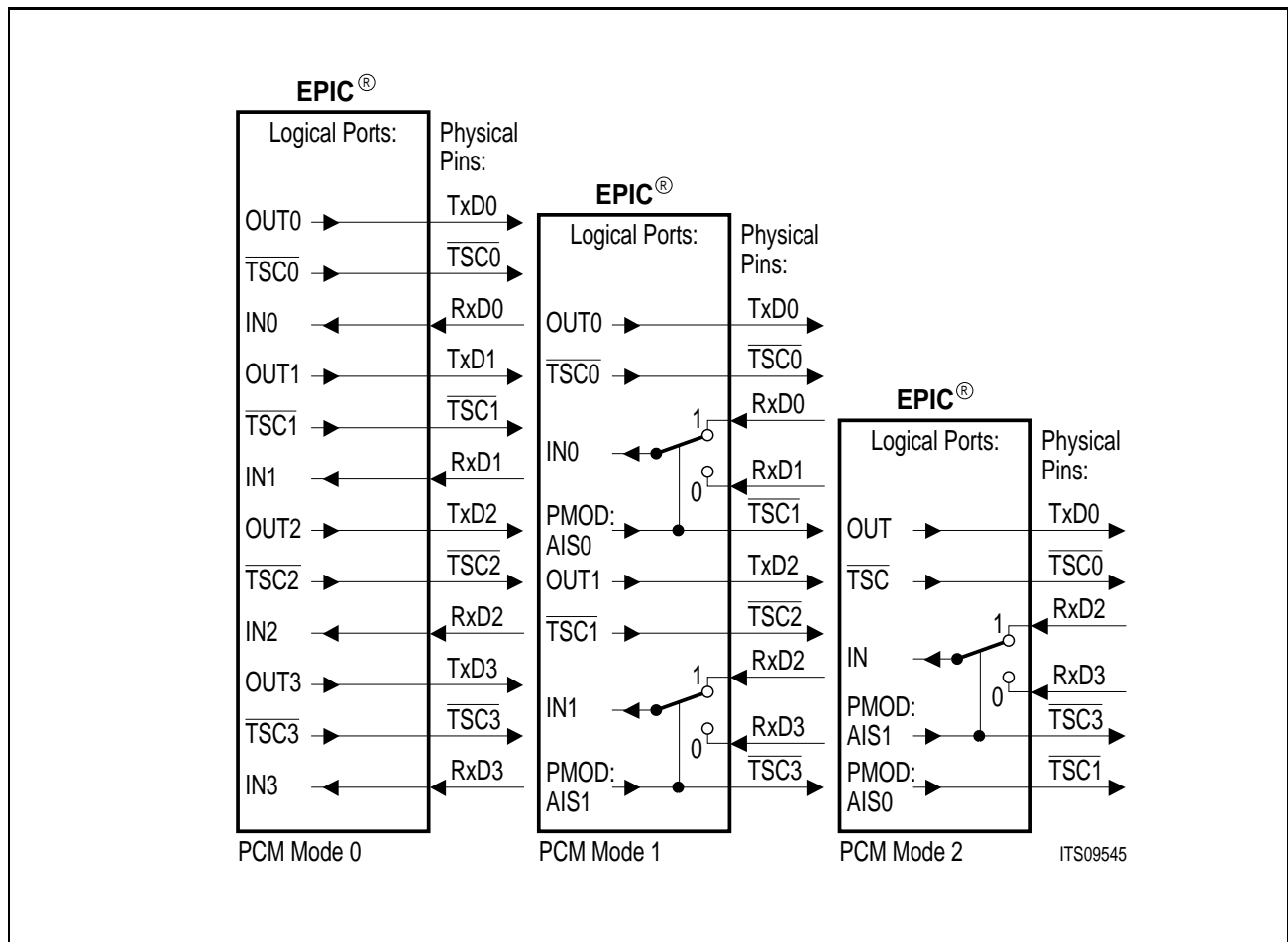

Figure 28
Correlation between Physical and Logical PCM Ports

PCM Input Comparison PMOD:AIC1 ... AIC0

If the PCM input comparison is enabled, the EPIC checks the contents of two PCM receive lines (physical ports) against each other for mismatches. (Also refer to **chapter 5.8.2**).

The comparison function is operational in all PCM modes, a redundant PCM line which can be switched over to by means of the PMOD:AIS bits is of course only available in PCM modes 1 and 2.

AIC0 set to logical 1 enables the comparison function between RxD0 and RxD1.

AIC1 set to logical 1 enables the comparison function between RxD2 and RxD3.

AIC1, AIC0 set to logical 0 disables the respective comparison function.

PCM Standby Mode OMDR:PSB

In standby mode (OMDR:PSB = 0), the PCM interface output pins TxD0 ... 3 are set to high impedance and those ($\overline{\text{TSC\#}}$) pins which are actually used as tristate control signals are set to logical 1 (inactive).

Note that the internal operation of the EPIC is not affected in standby mode, i.e. the received PCM data is still written into the downstream data memory and may still be processed by the EPIC (switched to the CFI or to the μP , compared with other input line, etc.)

In operational mode (OMDR:PSB = 1), the PCM output pins transmit the contents of the upstream data memory data field or may be set to high impedance via the data memory tristate field (refer to **chapter 5.3.3.2**).

PCM Test Loop OMDR:PTL

The PCM test loop function can be used for diagnostic purposes if desired. If however a “simple” CFI to CFI connection (CFI → PCM → CFI loop) shall be established, it is recommended to program the PCM loop in the control memory (refer to **chapter 5.4.3.1**).

If OMDR:PTL is set to logical 1, the test loop is enabled i.e. the physical transmit pins TxD# are internally connected to the corresponding physical receive pins RxD#, such that data transmitted over TxD# are internally looped back to RxD# and data externally received over RxD# are ignored. The TxD# pins still output the contents of the upstream data memory according to the setting of the tristate field.

Note: This loop back function can only work if the upstream and downstream bit shifts match and if the port assignment (PMOD:AIS1 ... 0) is such that a logical transmitter is looped back to a logical receiver (e.g. the PTL loop cannot work in PCM mode 2!).

For normal operation OMDR:PTL should be set to logical 0 (test loop disabled).

Figure 29 illustrates the effect of the PTL bit:

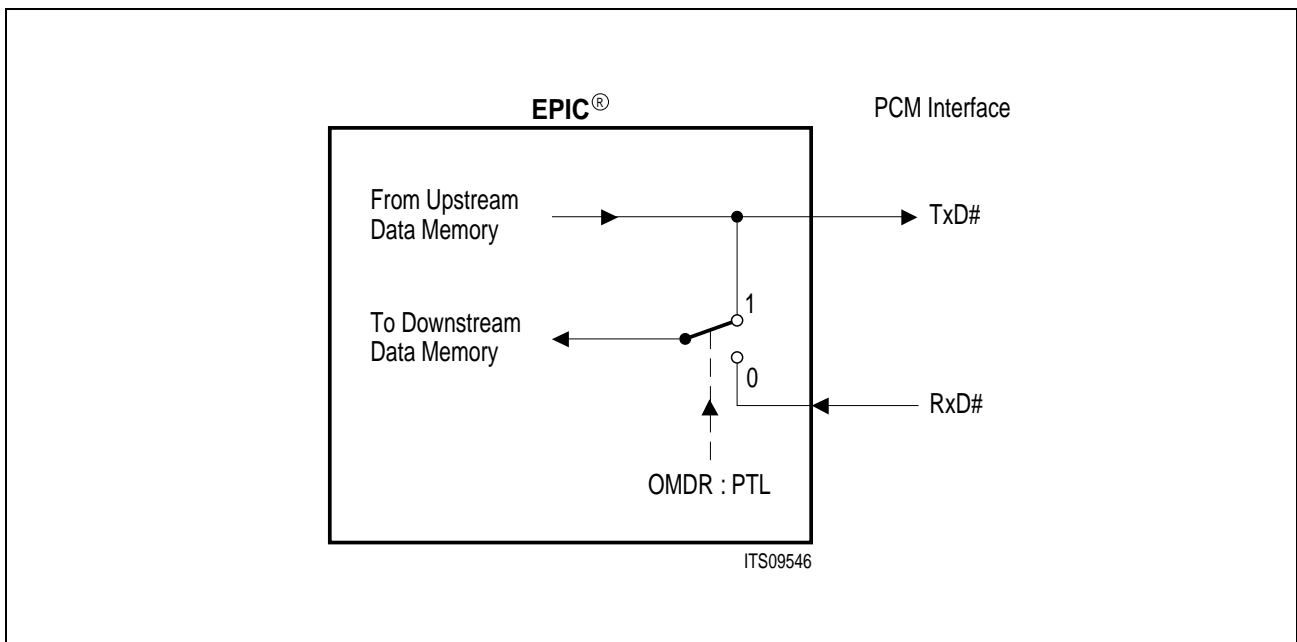

Figure 29
Effect of the OMDR:PTL Bit

5.2.2 Configurable Interface Configuration

5.2.2.1 CFI Interface Signals

The configurable interface signals are summarized in the table below:

Table 14

| Pin No. | Symbol | I: Input O: Output | Function |
|--|--|------------------------------|--|
| 40 41 42 ¹⁾ 43 ¹⁾ | DD0/SIP0 DD1/SIP1 DD2/SIP2 DD3/SIP3 | O/IO O/IO O/IO O/IO | Data downstream outputs in CFI modes 0, 1 and 2 (PCM and IOM applications). Bidirectional serial interface ports in CFI mode 3 (SLD application). Tristate or open drain output drivers selectable (OMDR: COS). |
| 38 37 36 ¹⁾ 35 ¹⁾ | DU0/SIP4 DU1/SIP5 DU2/SIP6 DU3/SIP7 | I/IO I/IO I/IO I/IO | Data upstream inputs in CFI modes 0, 1 and 2 (PCM and IOM applications). Bidirectional serial interface ports in CFI mode 3 (SLD application). Tristate or open drain output drivers for SIP lines selectable (OMDR: COS). |
| 34 | FSC | I or O | Frame synchronization input (CMD1: CSS = 1) or output (CMD1: CSS = 0). |
| 33 | DCL | I or O | Data clock input (CMD1: CSS = 1) or output (CMD1: CSS = 0). |

1) Only EPIC-1

5.2.2.2 CFI Registers

The characteristics at the configurable interface (timing, modes of operation, etc. ...) are programmed in the 6 CFI interface registers and the Operation Mode Register OMDR. The function of each bit is described in **chapter 5.2.2.3**. For addresses refer to **chapter 4.1**.

CFI Mode Register 1

read/write

reset value:

00_H

bit 7

bit 0

| | | | | | | | | |
|------|-----|-----|------|------|------|------|------|------|
| CMD1 | CCS | CSM | CSP1 | CSP0 | CMD1 | CMD0 | CIS1 | CIS0 |
|------|-----|-----|------|------|------|------|------|------|

Application Hints

CFI Mode Register 2 read/write reset value: 00_H

| | | | | | | | | |
|------|-------|-----|-----|-----|-----|-----|------|-------|
| | bit 7 | | | | | | | bit 0 |
| CMD2 | FC2 | FC1 | FC0 | COC | CXF | CRR | CBN9 | CBN8 |

CFI Bit Number Register read/write reset value: FF_H

| | | | | | | | | |
|------|-------|------|------|------|------|------|------|-------|
| | bit 7 | | | | | | | bit 0 |
| CBNR | CBN7 | CBN6 | CBN5 | CBN4 | CBN3 | CBN2 | CBN1 | CBN0 |

CFI Time Slot Adjustment Register read/write reset value: 00_H

| | | | | | | | | |
|------|-------|------|------|------|------|------|------|-------|
| | bit 7 | | | | | | | bit 0 |
| CTAR | 0 | TSN6 | TSN5 | TSN4 | TSN3 | TSN2 | TSN1 | TSN0 |

CFI Bit Shift Register read/write reset value: 00_H

| | | | | | | | | |
|------|-------|------|------|------|------|------|------|-------|
| | bit 7 | | | | | | | bit 0 |
| CBSR | 0 | CDS2 | CDS1 | CDS0 | CUS3 | CUS2 | CUS1 | CUS0 |

CFI Bit Subchannel Register read/write reset value: 00_H

| | | | | | | | | |
|------|-------|------|------|------|------|------|------|-------|
| | bit 7 | | | | | | | bit 0 |
| CSCR | SC31 | SC30 | SC21 | SC20 | SC11 | SC10 | SC01 | SC00 |

Operation Mode Register read/write reset value: 00_H

| | | | | | | | | |
|------|-------|------|-----|-----|------------|------|------------|-------|
| | bit 7 | | | | | | | bit 0 |
| OMDR | OMS1 | OMS0 | PSB | PTL | COS | MFPS | CSB | RBS |

5.2.2.3 CFI Characteristics

In the following the configurable interface characteristics that can be programmed in the CFI registers are explained in more detail.

CFI Mode CMD1:CMD1, CMD0

The CFI mode primarily defines the actual number of CFI ports that can be used for switching purposes (logical ports). 1, 2 or 4 duplex or 8 bidirectional logical CFI ports can be selected. Since the channel capacity of the EPIC is constant (128 channels/direction), the CFI mode also influences the maximum possible data rate.

In each CFI mode a reference clock (RCL) of a specific frequency is required. This clock may be derived from the PCM clock signal PDC (CMD1:CSS = 0) or from the DCL signal (CMD1:CSS = 1). Also refer to **figure 30** and **figure 31**.

Table 15 states the specific characteristics of each CFI mode.

(DR = CFI data rate, N = number of 8 bit time slots in PCM frame, du = duplex port, bi = bidirectional port).

Table 15

| CMD1 | CMD0 | CFI Mode | Number (Label) of Logical Ports | CFI Data Rate [kbit/s] | | Min. Required CFI DR [kbit/s] relative to PCM Data Rate | Necessary Reference Clock (RCL) | DCL Output Frequencies CMD1: CSS = 0 |
|------|------|----------|---------------------------------|------------------------|------|---|---------------------------------|--------------------------------------|
| | | | | min. | max. | | | |
| 1 | 1 | 3 | 8 bi (0 ... 7) | 128 | 1024 | 16N/3 | 4 × DR | DR, 2 × DR |
| 0 | 0 | 0 | 4 du (0 ... 3) | 128 | 2048 | 32N/3 | 2 × DR | DR, 2 × DR |
| 0 | 1 | 1 | 2 du (0 ... 1) | 128 | 4096 | 64N/3 | DR | DR |
| 1 | 0 | 2 | 1 du | 128 | 8192 | 64N/3 | 0.5 × DR | DR |

*Note: The label is used to specify a CFI port when programming a switching function. It should not be confused with the physical port number which refers to actual hardware pins. The relationship between logical and physical port numbers is given in **table 19** and is illustrated in **figure 46**.*

Important Note

It should be noticed that there are some restrictions concerning the PCM to CFI data rate ratio. If the CFI data rate is chosen higher than the PCM data rate, no restrictions apply. If however the CFI data rate is lower than the PCM data rate, a minimum CFI data rate relative to the PCM data rate must be maintained (refer also to examples below).

Another important restriction is, that the number of bits per CFI frame must always be modulo 16.

Examples

If the PCM frame consists of 32 time slots (2.048 Mbit/s), the minimum possible CFI data rate in CFI mode 0 is $(32 \times 32)/3 = 341.3$ kbit/s or if rounded to an integer number of time slots 344 kbit/s. It is thus not possible to have an IOM-1 interface with 256 kbit/s together with a 2.048 Mbit/s PCM interface in CFI mode 0. If instead the PCM frame consists of 24 time slots (1.536 Mbit/s), the IOM-1 data rate of 256 kbit/s is feasible since $(24 \times 32)/3 = 256$ kbit/s.

CFI Clock and Framing Signal Source CMD1:CSS

The PCM interface is always clocked and synchronized by the PDC and PFS input signals. The configurable interface however can be clocked and synchronized either by signals internally derived from PDC and PFS or it can be clocked and synchronized by the externally applied DCL and FSC input signals.

If **PDC** and **PFS** are selected as **clock and framing signal source** (CMD1:CSS = 0), the CFI reference clock CRCL is obtained out of PDC after division by 1, 1.5 or 2 according to the prescaler selection (CMD:CSP1 ... 0). The CFI frame structure is synchronized by the PFS input signal. The EPIC generates DCL and FSC as output signals which may be specified by CMD2:COC (DCL clock rate) and CMD2:FC2 ... 0 (FSC pulse form). This mode should be selected whenever the required CFI data rate can be obtained out of the PCM clock source using the internal prescalers. An overview of the different possibilities to generate the PCM and CFI data and clock rates for CMD1:CSS = 0 is given in **figure 30**.

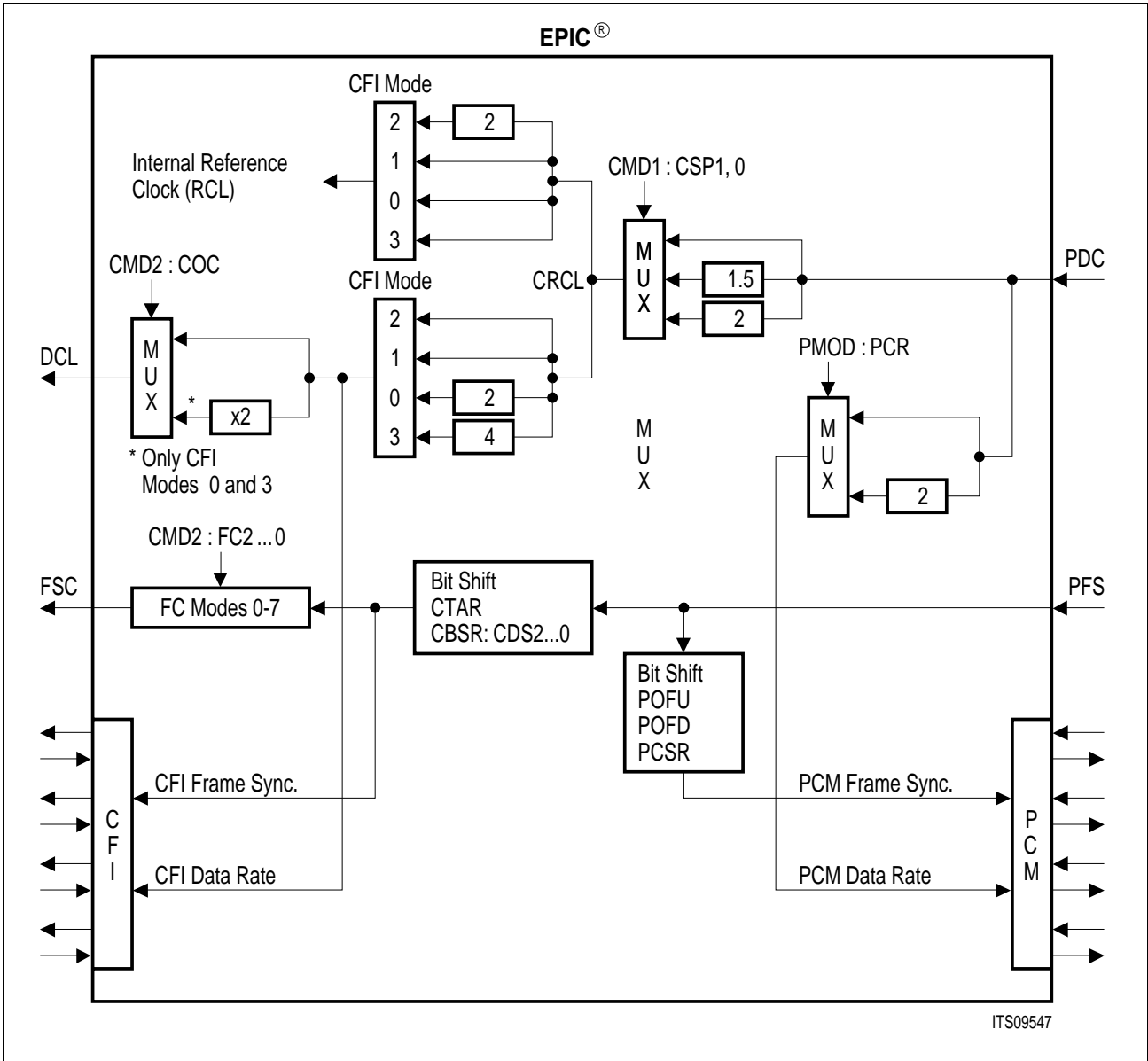

Figure 30
EPIC® Clock Sources for the CFI and PCM Interfaces if CMD1:CSS = 0

If **DCL** and **FSC** are selected as **clock and framing signal source** (CMD1:CSS = 1), the CFI reference clock CRCL is obtained out of the DCL input signal after division by 1, 1.5 or 2 according to the prescaler selection (CMD1:CSP1 ... 0). The CFI frame structure is synchronized by the FSC input signal. Note that although the frequency and phase of DCL and FSC may be chosen almost independently with respect to the frequency and phase of PDC and PFS, the CFI clock source must still be synchronous to the PCM interface clock source i.e. the two clock sources must always be derived from one master clock. This mode must be selected if it is impossible to derive the required CFI data rate from the PCM clock source. An overview of the different possibilities to generate the PCM and CFI data and clock rates for CMD1:CSS = 1 is given in **figure 31**.

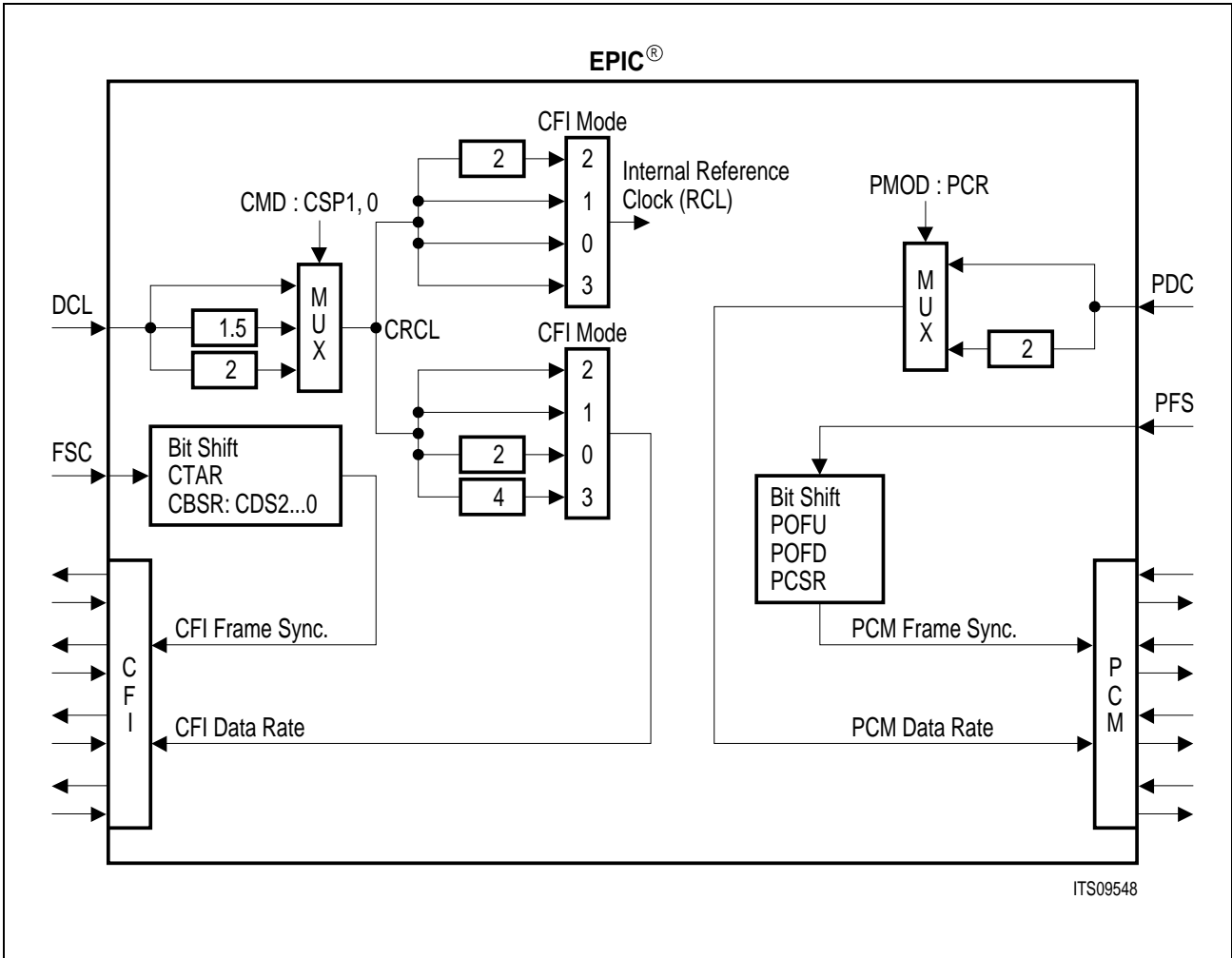

Figure 31
EPIC® Clock Sources for the CFI and PCM Interfaces if CMD1:CSS = 1

CFI Clock Source Prescaler CMD1:CSP1 ... 0

The CFI clock source PDC (CMD1:CSS = 0) or DCL (CMD1:CSS = 1) can be divided by a factor of 1, 1.5 or 2 in order to obtain the CFI reference clock CRCL (see **table 16**). Note that in CFI mode 2, the frequency of RCL is only half the CFI data rate.

Table 16

| CSP1 | CSP0 | Prescaler Divisor |
|------|------|-------------------|
| 0 | 0 | 2 |
| 0 | 1 | 1.5 |
| 1 | 0 | 1 |
| 1 | 1 | not allowed |

Figure 32 shows the relationship between the DCL input and the generated RCL for the different prescaler divisors in case $CMD1:CSS = 1$:

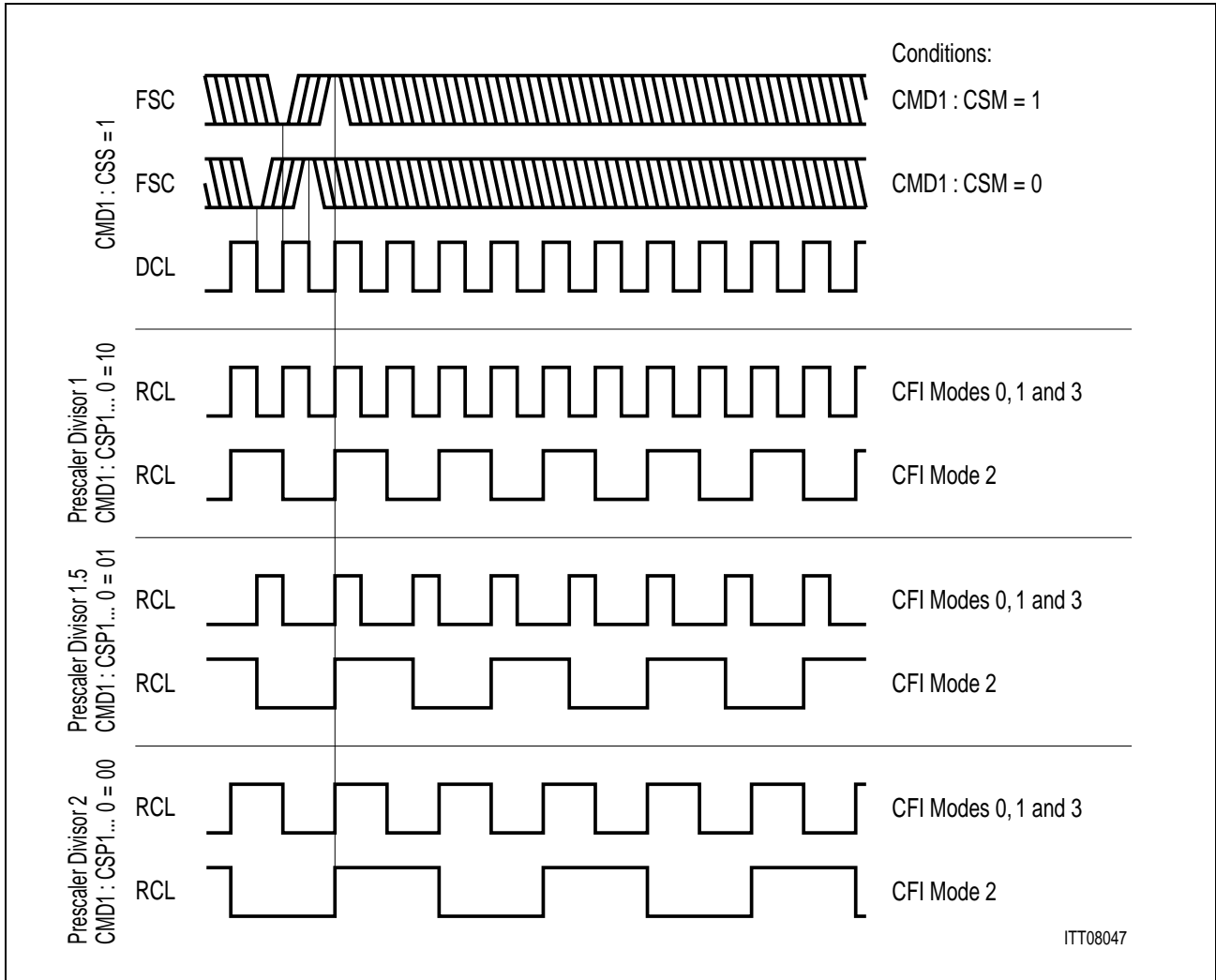

Figure 32
Clock Signal Timing for the Different Prescaler Divisors if $CMD1:CSS = 1$

CFI Clock Output Rate $CMD2:COC$

This feature applies only if the configurable interface is clocked and synchronized via the PCM interface clock and framing signals (PDC, PFS), i.e. if $CMD1:CSS = 0$.

In this case the EPIC delivers an output clock signal at pin DCL with a frequency identical to or double the selected CFI data rate:

For $CMD2:COC = 0$, the frequency of DCL is identical to the CFI data rate
(all CFI modes)

For $CMD2:COC = 1$, the frequency of DCL is twice the CFI data rate
(CFI modes 0 and 3 only!)

Figure 33 shows the relationship between the PFS, PDC, RCL and DCL signals in the different CFI modes.

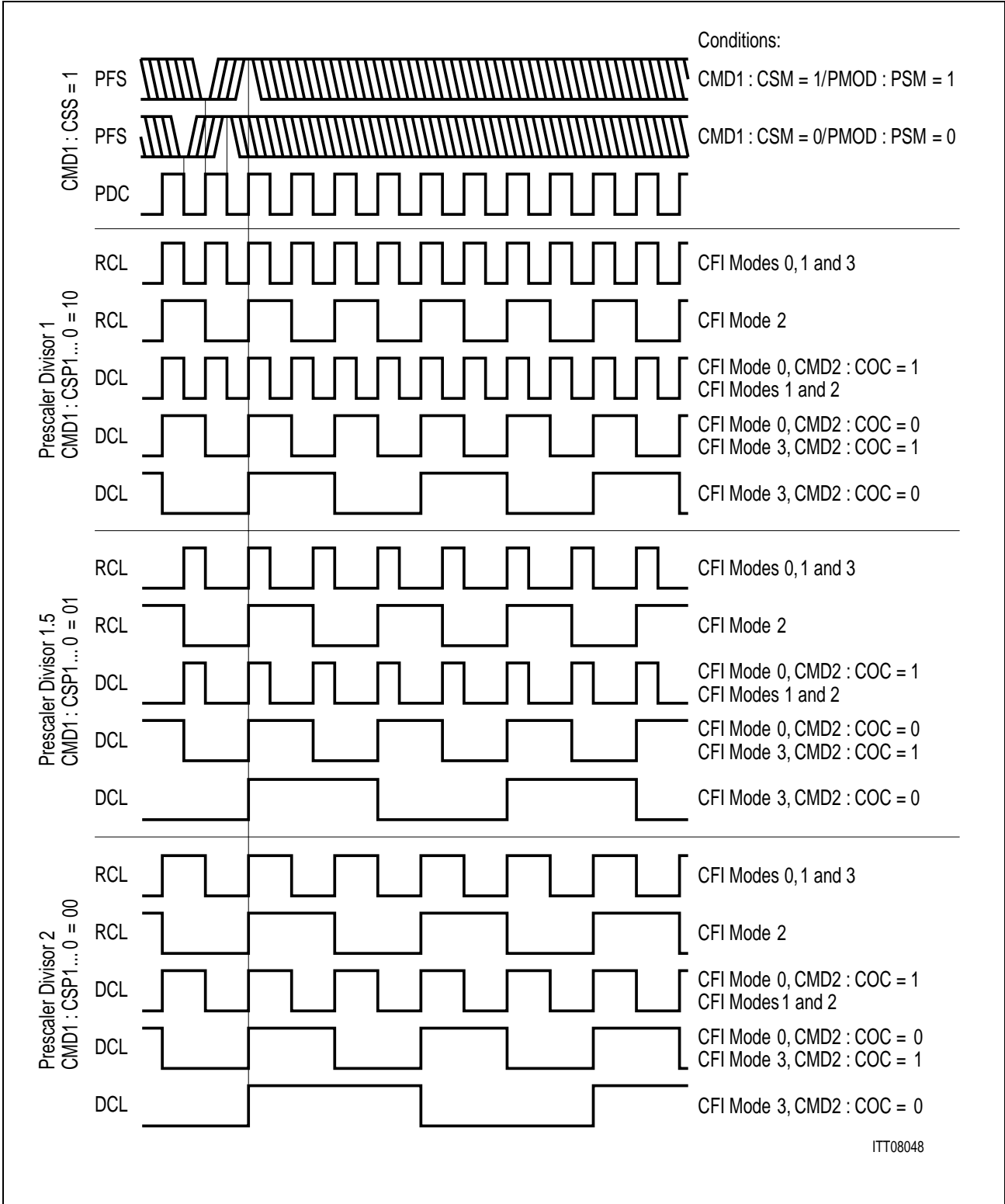

Figure 33
Clock Signal Timing for the Different Prescaler Divisors if CMD1:CSS = 0

CFI Framing Signal Output Control CMD2:FC2 ... 0

This feature applies only if the configurable interface is clocked and synchronized via the PCM interface clock and framing signals (PDC, PFS), i.e. if CMD1:CSS = 0.

In this case the EPIC delivers an output framing signal at pin FSC with a programmable pulse width and position.

Note that the up- and downstream CFI frame position relative to the FSC output is not affected by the setting of the CTAR and CBSR:CDS2 ... 0 register bits.

Table 17 summarizes the 7 possible FSC Control (FC) modes:

Table 17

| FC2 | FC1 | FC0 | FC Mode | Main Applications | Notes |
|-----|-----|-----|---------|--|--|
| 0 | 0 | 0 | 0 | IOM-1 multiplexed (burst) mode | SBC, IBC, IEC-T |
| 0 | 0 | 1 | 1 | General purpose | |
| 0 | 1 | 0 | 2 | General purpose | |
| 0 | 1 | 1 | 3 | General purpose | |
| 1 | 0 | 0 | 4 | Special SLD application | 2 ISAC-S per SLD port |
| 1 | 0 | 1 | 5 | reserved | |
| 1 | 1 | 0 | 6 | IOM-2, IOM-1 or SLD modes | Standard IOM-2 setting; no Superframes generated |
| 1 | 1 | 1 | 7 | Software timed multiplexed IOM-2 applications | Standard IOM-2 setting; Superframes generated |

Figure 34 and figure 35 show the position of the FSC pulse relative to the CFI frame:

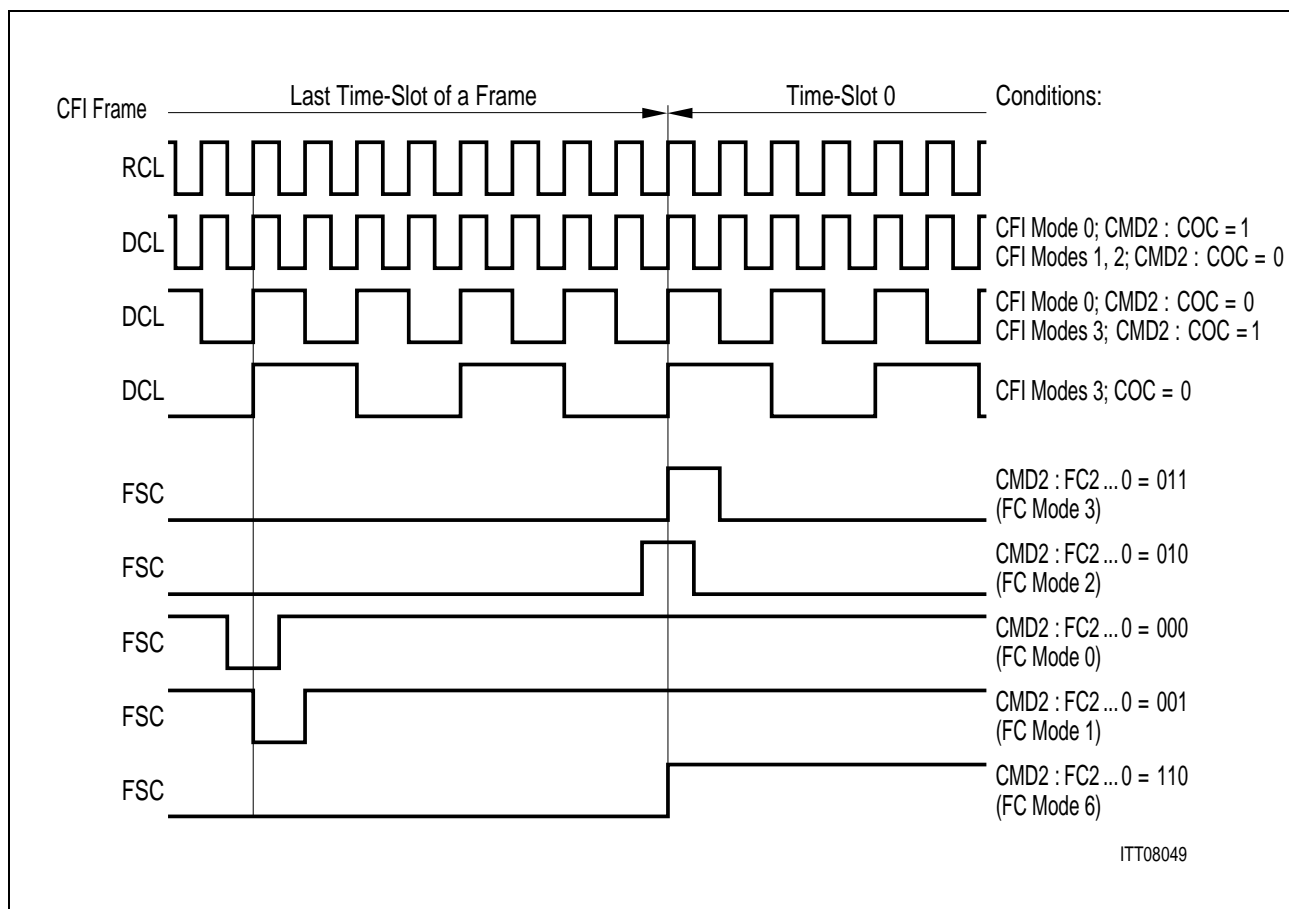

Figure 34
Position of the FSC Signal for FC Modes 0, 1, 2, 3 and 6

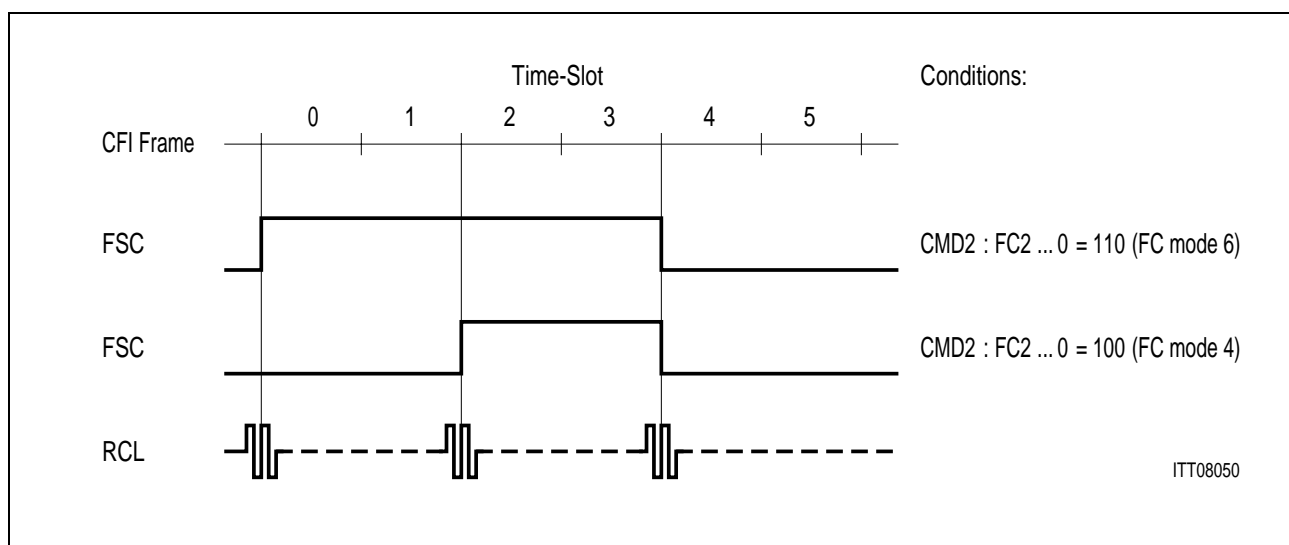

Figure 35
Position of the FSC Signal for FC Modes 4 and 6

Application Examples of the Different FC Modes

FC Mode 0

FC mode 0 applies for IOM-1 multiplexed mode applications, i.e. for IOM-1 interfaces with 2.048 Mbit/s data rate. Accommodated layer-1 devices: SBC (PEB 2080), IBC (PEB 2095), IEC-T (PEB 20901/20902), ...

In IOM-1 mux. mode, the frame is synchronized with a negative pulse with a duration of one DCL period which marks bit number 251. The bits are transmitted with the falling clock edge and received with the rising clock edge.

Required register setting: $CMD1 = 0XXX0000_B$, $CMD2 = 1C_H$, $CBNR = FF_H$, $CTAR = XX_H$, $CBSR = X0_H$.

Figure 36 shows the relationship between FSC, DCL, DD# and DU#:

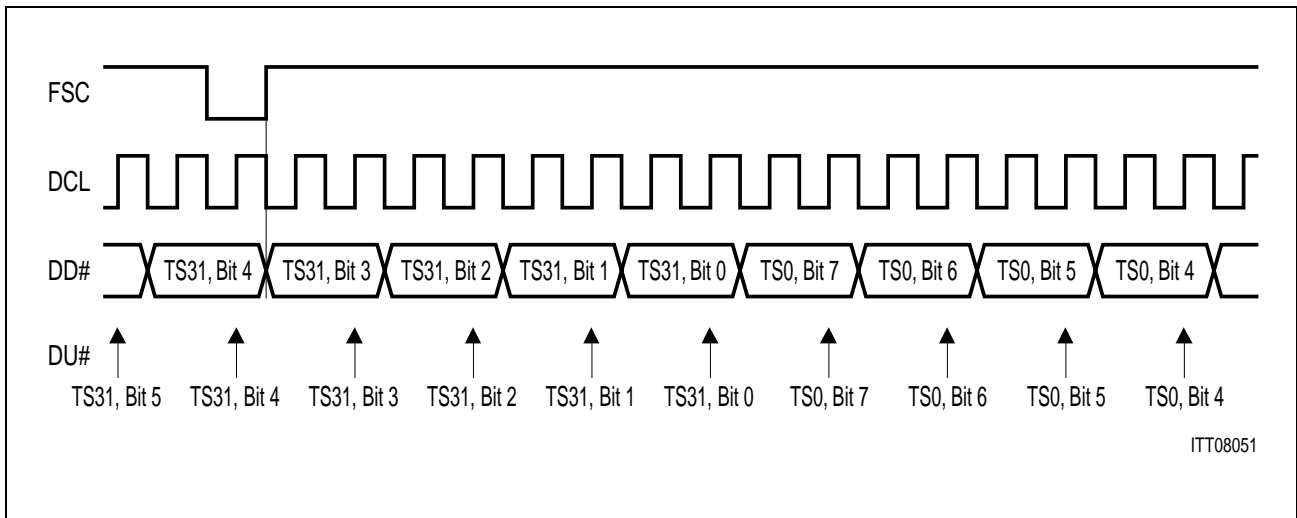

Figure 36
Multiplexed IOM[®]-1 Interface Signals

FC Mode 1

FC mode 1 is similar to FC mode 0. The FSC pulse is shifted by half a RCL period to the right compared to FC mode 0. It can be used for general purposes.

FC Mode 2

FC mode 2 is similar to FC mode 3. The FSC pulse is shifted by half a RCL period to the left compared to FC mode 3. It can be used for general purposes.

FC Mode 3

FC mode 3 can be used for IOM-2 applications, but it should be noted that some IOM-2 layer-1 transceivers will interpret an FSC pulse of only one DCL period as a superframe marker (e.g. SBCX PEB 2081, IEC-Q PEB 2091, ...), and it is not allowed to provide a superframe marker in every frame. For these applications it is recommended to use either FC mode 6 or FC mode 7.

FC Mode 4

FC mode 4 applies for special SLD applications like 2 ISAC-S devices connected to one SIP line. Usually each SIP line carries the two 64 kbit/s B channels followed by a feature control and a signaling channel. The feature control and signaling channels however are not required for all applications. This is, for example, the case if a digital subscriber circuit (S- or U- layer-1 transceiver) is connected via an ISDN Communication Controller (ICC PEB 2070) to the EPIC. The task of the ICC is to handle the D-channel and to switch the B1 and B2 channels from the SLD to the IOM-1 interface. The capacity of such an SLD line card can be doubled if the unused time slots for the feature control and signaling channels are also used as 64 kbit/s B channels. This is possible if the additionally connected ICC (or ISAC-S) is synchronized with an FSC that is delayed by 2 time slots i.e. the rising FSC edge is at the beginning of time slot 2 instead of 0. The CFI time slots 2, 3, 6 and 7 can then be programmed as normal B channels within the EPIC instead of being programmed as feature control and signaling channels.

FC Mode 6

This is the most often used type of FSC signal, because it covers the standard IOM-1, IOM-2 and SLD applications. The rising edge of FSC marks time slot 0, bit 7 of the CFI frame.

The pulse width is 32 bits or 4 time slots, i.e. the FSC is symmetrical (duty cycle 1:1) if the CFI frame consists of 8 time slots (SLD), and the FSC is high during the first IOM-2 channel if the CFI frame consists of 32 time slots (IOM-2).

Required register setting for IOM-2:

CMD1 = 0XXX0000_B, CMD2 = D0_H, CBNR = FF_H, CTAR = XX_H, CBSR = X0_H.

Figure 37 shows the relationship between FSC, DCL, DD# and DU#:

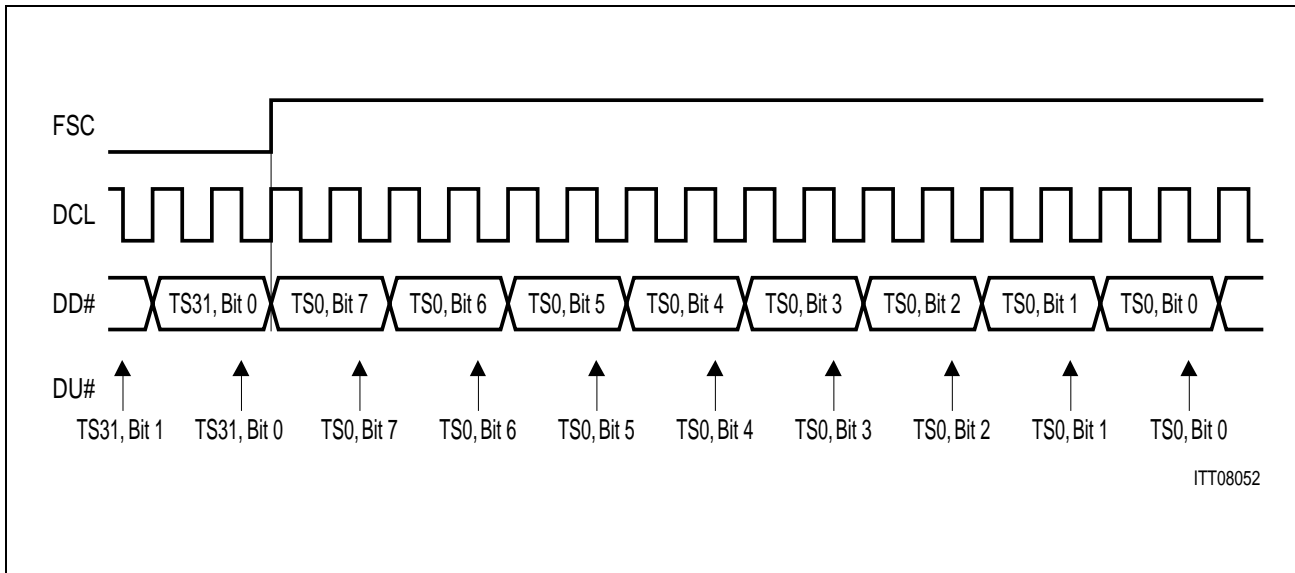

Figure 37
IOM[®]-2 Interface Signals

Required register setting for SLD:

CMD1 = 0XXX1100_B, CMD2 = D0_H, CBNR = 1F_H, CTAR = XX_H, CBSR = X0_H.

Figure 38 shows the relationship between FSC, DCL and SIP#:

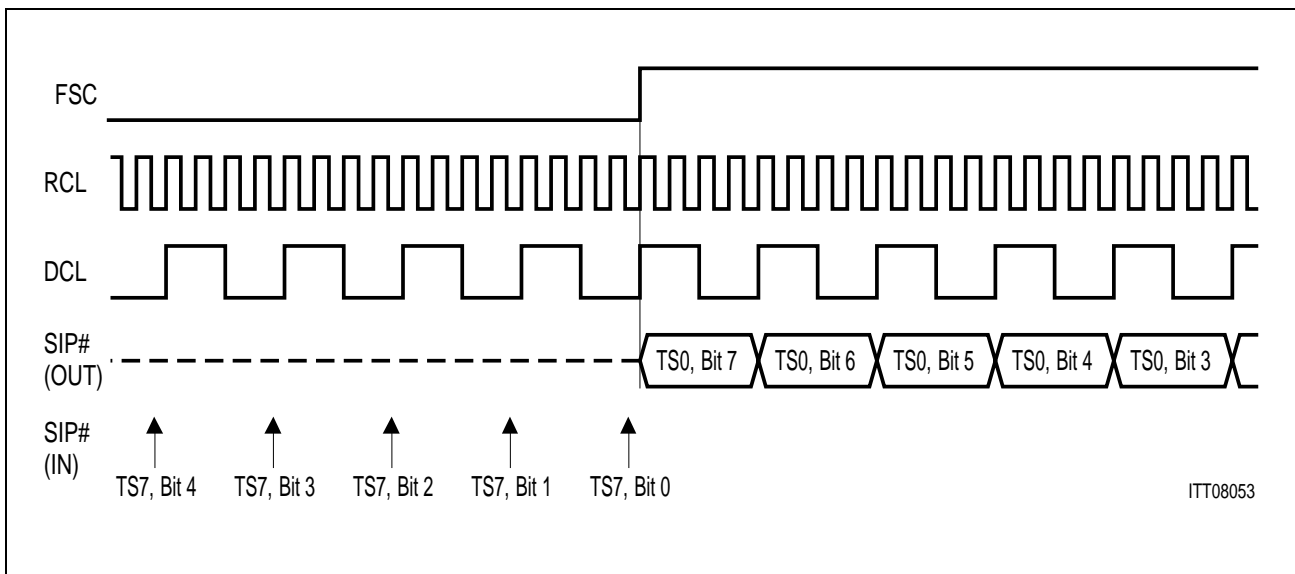

Figure 38
SLD Interface Signals

FC Mode 7

FC mode 7 is intended for IOM-2 line cards to synchronize the multiframe structure among several S- or U_k-interface transceivers. The layer-1 multiframe is reset by an FSC pulse having a width of at most, one DCL period. Between the multiframe reset pulses, FSC pulses with a width of at least two DCL periods must be applied. Devices which support this option are for example the OCTAT-P (PEB 2096-H), QUAT-S (PEB 2084-H), SBCX (PEB 2081), and the IEC-Q (PEB 2091).

FC mode 7 is a combination of FC modes 3 and 6. The timer register TIMR must be loaded with the required multiframe period (e.g. 5 ms for the S-interface or 12 ms for the U_k-interface). When the timer is started with CMDR:ST, a cyclic multiplexing process is started: whenever the timer expires, the frame signal has the pulse shape of FC mode 3 during one frame. For all the other frames the FSC signal has the pulse form of FC mode 6.

After setting the CMDR:ST bit, the inverted value of TVAL is loaded to the timer and the timer is incremented as soon as time slot 3 is passed (i.e. the FSC high phase is passed which lasts for 4 TSs in FC mode 6) and then every 250 μs.

When the timer expires (timer value = 0), an interrupt is generated immediately and the next FSC pulse has the shape of FC mode 3.

Figure 39 illustrates this behavior for a timer value of TVAL6 ... 0 = 0000001.

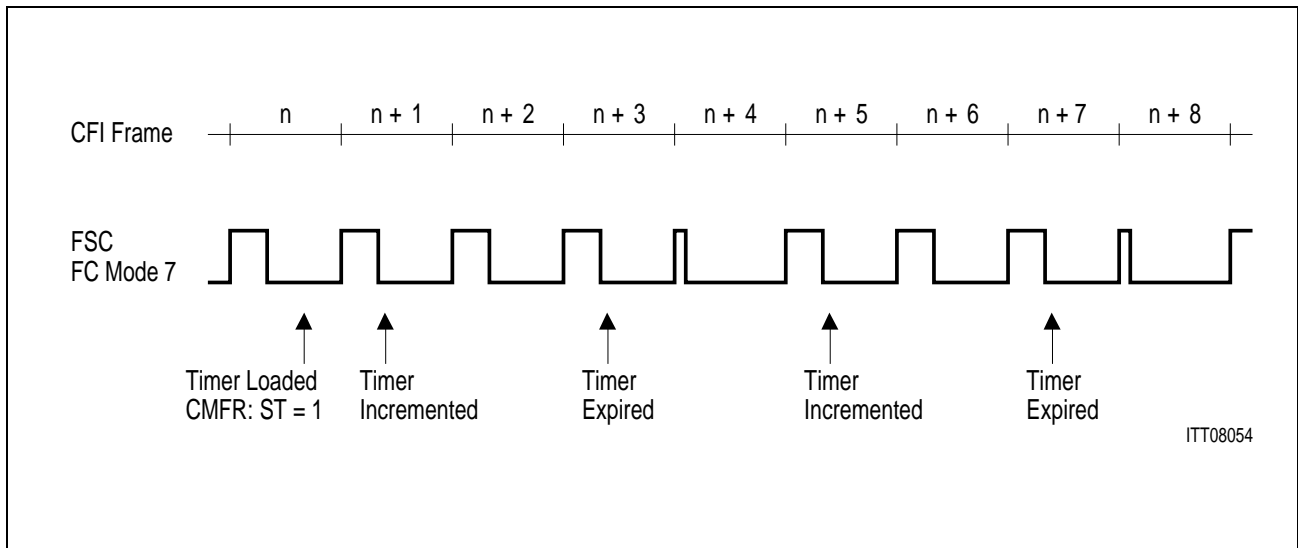

Figure 39
FSC Signal in FC Mode 7

Note: If the timer is stopped, the generated pulse form is the one of FC mode 6.

Timer value examples:

Required timer value for 5 ms period: TIMR:TVAL6 ... 0 = 010011_B, e.g. TIMR = 13_H

Required timer value for 12 ms period: TIMR:TVAL6 ... 0 = 101111_B, e.g. TIMR = 2F_H

CFI Bit Number CMD2, CBNR:CBN9 ... CBN0

The CFI data rate is determined by the reference clock RCL and the CFI mode selected by CMD1:CMD1 ... 0. The number of bits which constitute a CFI frame can be derived from this data rate by division of 8000 (8 kHz frame structure). If the CFI interface is for example operated at 2.048 Mbit/s, the frame would consist of 256 bits or 32 time slots.

This number of bits must be programmed to CMD2, CBNR:CBN9 ... 0 as indicated below. Note that the formula is valid for all CFI modes:

$$\text{CBN9 ... 0} = \text{number of bits} - 1$$

Examples

A CFI frame consisting of 64 time slots would require a setting of

$$\text{CBN9 ... 0} = 64 \times 8 - 1 = 511\text{D} = 01\ 1111\ 1111\text{B}$$

A CFI frame consisting of 48 time slots would require a setting of

$$\text{CBN9 ... 0} = 48 \times 8 - 1 = 383\text{D} = 01\ 0111\ 1111\text{B}$$

CFI Synchronization Mode CMD1:CSM

The CFI interface can either be synchronized via the PFS pin (CMD1:CSS = 0), or via the FSC pin (CMD1:CSS = 1). A transition from low to high of either PFS or FSC synchronizes the CFI frame. The PFS (FSC) signal is internally sampled with the PDC (DCL) clock:

If CSM is set to logical 0, the PFS/FSC signal is sampled with the falling clock edge of PDC/DCL, if set to logical 1, the PFS/FSC signal is sampled with the rising clock edge of PDC/DCL.

If CMD1:CSS is set to logical 0 (CFI clocks are internally derived from the PCM clocks), then CMD1:CSM should be equal to PMOD:PSM.

If CMD1:CSS is set to logical 1 (CFI clock signals are inputs), then CMD1:CSM should be selected such that stable low and high phases of the FSC signal can be detected, meeting the set-up (T_{FS}) and hold (T_{FH}) times with respect to the programmed DCL clock edge.

The high phase of the PFS/FSC pulse may be of arbitrary length, however it must be assured that it is sampled low at least once before the next framing pulse.

The relationship between the framing and clock signals (PFS, FSC, PDC, DCL and RCL) for the different modes of operation is illustrated in **figures 32** and **33**.

Note: In case DCL and FSC are selected as inputs (CMD1:CSS = 1), FSC must always be synchronized with the positive edge of DCL (CMD1:CSM = 1). Otherwise, an IOM-2 compatible timing cannot be installed by means of a bit shift (When the negative edge is used for synchronization the internal frame start is delayed by one DCL clock. In double rate mode a bit shift of half a bit cannot be adjusted). Anyway, if the rising edges of DCL and FSC do not meet the frame setup time T_{FS} ,

additional hardware must delay the frame signal to enable a synchronization with the positive edge of DCL. **Figure 40** gives a suggestion of how to adapt the external timing.

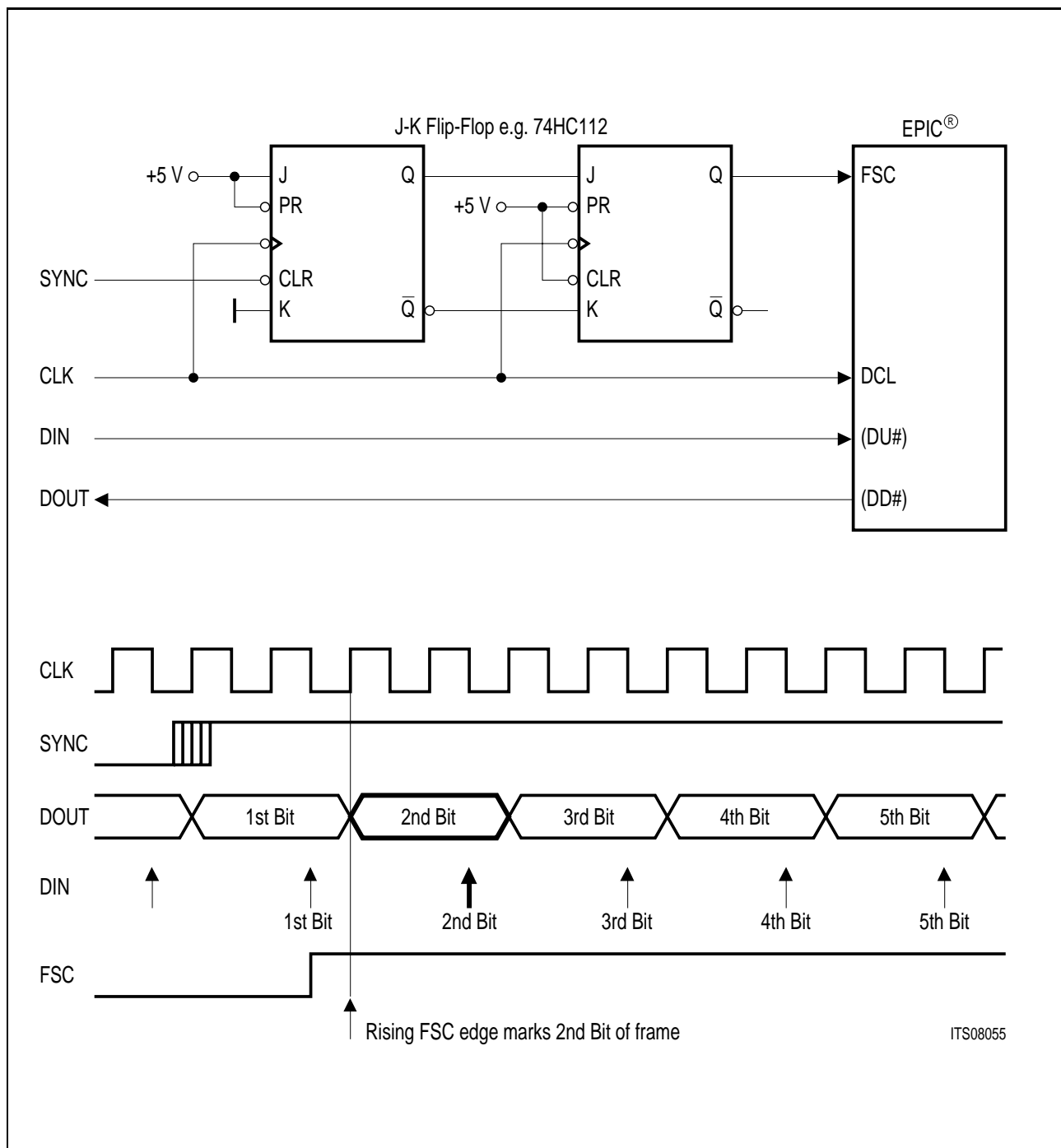

Figure 40
Circuit for Delaying the Framing Signal at the CFI Interface

CFI Bit Timing and Bit Shift CMD2, CTAR, CBSR

The position of the CFI frame can be shifted relative to the CFI frame synchronization pulse using the CFI Time slot Adjustment Register CTAR and the CFI Bit Shift Register CBSR. This shifting can be performed simultaneously for up- and downstream directions with a one bit resolution by up to a whole frame. The upstream frame can additionally be shifted relative to the downstream frame by up to 15 bits. Furthermore, the polarity of the clock edge (CRCL) used for transmitting and sampling the data can be programmed in the CMD2 register.

Since the frame synchronization source of the configurable interface is either PFS (for CMD1:CSS = 0) or FSC (for CMD1:CSS = 1), the bit shift also refers to either the PFS or the FSC framing signal.

*Note: If **PFS/PDC** is selected as CFI **sync/clock source**, the time slot and bit shift values programmed to CTAR and CBSR:CDS2 ... 0 affect both the CFI data lines and the CFI output framing signal FSC. The CFI frame together with the FSC signal can thus be shifted with respect to the PCM frame (PFS). The position of the CFI frame relative to the FSC output signal is not affected by these settings but is instead determined by the FSC framing control mode programmed to CMD2:FC2 ... 0. The upstream CFI frame can, however, still be shifted relative to the downstream CFI frame with the CBSR:CUS3 ... 0 bits.*

If **FSC/DCL** is selected as CFI **sync/clock source**, the time slot and bit shift functions affect the CFI frame with respect to the FSC framing input signal. In this case, the CFI frame start can be selected completely independently from the PCM frame start, it must only be assured that a phase relationship once established between the CFI and PCM frames is maintained all the time.

CFI Time Slot Adjustment and Bit Shift

If CBSR = 20_H, the CFI framing signal (PFS if CMD1:CSS = 0 or FSC if CMD1:CSS = 1) marks bit 7 of the CFI time slot called **TSN** according to the following formula:

CTAR:TSN6 ... 0 = TSN + 2

e.g. CTAR must be set to 02_H if the framing signal should mark time slot 0, bit 7 (TS = 0). See examples.

Note that the value of TSN may not exceed the actual number of time slots per CFI frame:

$TSN = [-2; I - 3]$, I = total number of time slots per CFI frame

From the zero offset bit position (CBSR = 20_H) the CFI frame (downstream and upstream) can be shifted by up to 5 bits to the left (within the time slot number TSN programmed in CTAR) and by up to 2 bits to the right (within the previous time slot N – 1) by programming the CBSR:CDS2 ... 0 bits:

Table 18

| CBSR:CDS2 ... 0 | Time Slot # | Marked Bit # | Bit Shift |
|------------------------|--------------------|---------------------|---------------------|
| 000 | TSN – 1 | 1 | 2 bits to the right |
| 001 | TSN – 1 | 0 | 1 bit to the right |
| 010 | TSN | 7 | no bit shift |
| 011 | TSN | 6 | 1 bit to the left |
| 100 | TSN | 5 | 2 bits to the left |
| 101 | TSN | 4 | 3 bits to the left |
| 110 | TSN | 3 | 4 bits to the left |
| 111 | TSN | 2 | 5 bits to the left |

The bit shift programmed to CBSR:CDS2 ... 0 affects both the upstream and downstream frame position in the same way.

If CBSR:CUS3 ... 0 = 0000, the upstream frame is aligned to the downstream frame.

With CBSR:CUS3 ... 0 = 0001 to 1111, the upstream CFI frame can be shifted relative to the downstream frame by up to 15 bits to the left as indicated in **figure 41**.

Application Hints

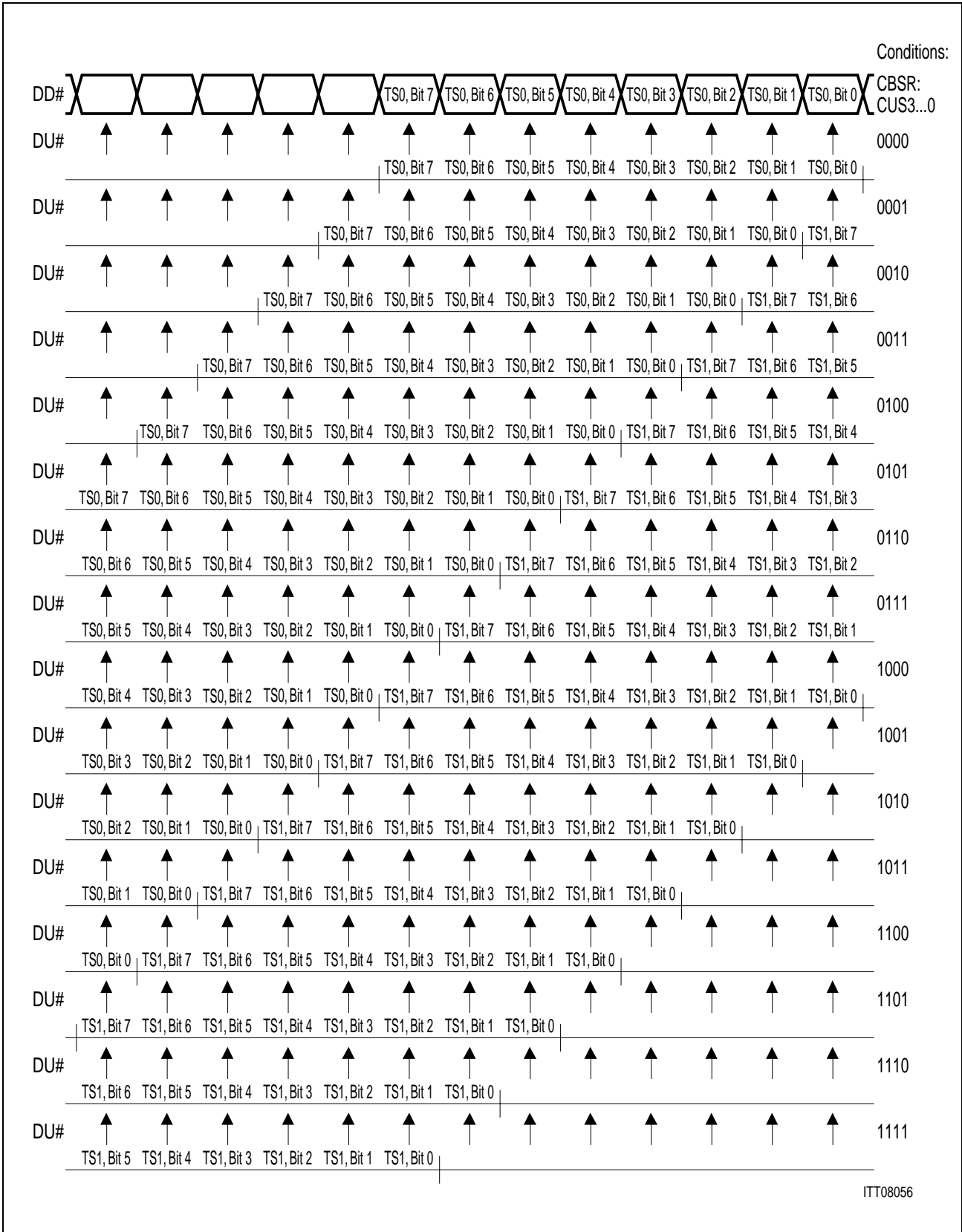

Figure 41
CFI Upstream Bit Shifting

CFI Bit Timing

In CFI modes 0, 1 and 2, the rising or falling **CRCL** clock edge can be selected for transmitting and sampling the data.

In CFI mode 3, the rising or falling **CRCL** clock edge can be selected for transmitting the data, the sampling of data however must always be done with the falling edge of CRCL (CRR = 0).

If CMD2:CXF = 0 (CFI Transmit on Falling edge), the data is transmitted with the rising CRCL edge, if CXF = 1, the data is transmitted with the next following falling edge of CRCL.

If CMD2:CRR = 0 (CFI Receive on Rising edge), the data is sampled with the falling CRCL edge, if CRR = 1, the data is sampled with the next following rising edge of CRCL.

The relationship between the framing and clock signals and the CFI bit stream on DD# and DU# for CTAR = 02_H and CBSR = 20_H are illustrated in **figure 42** and **figure 43**.

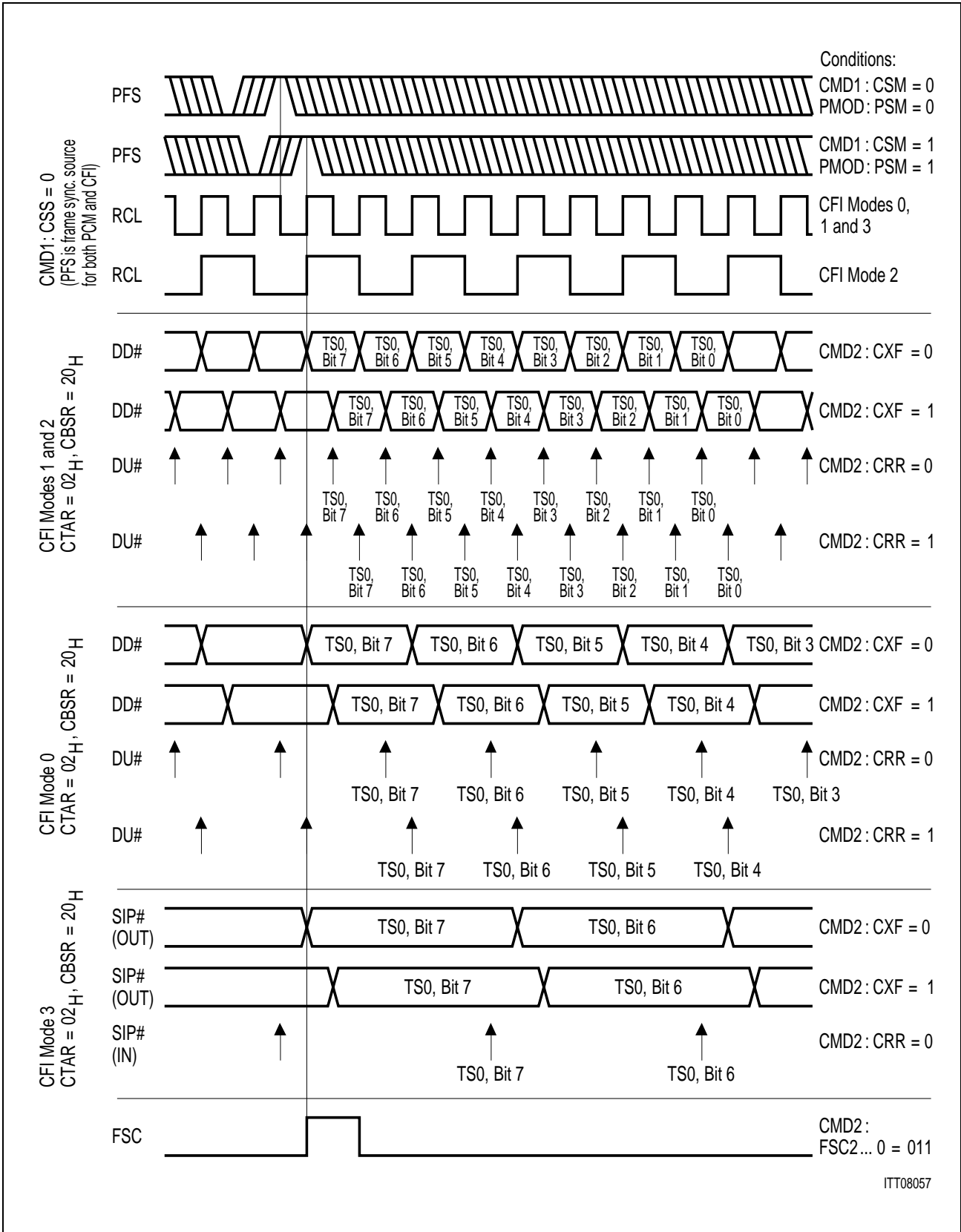
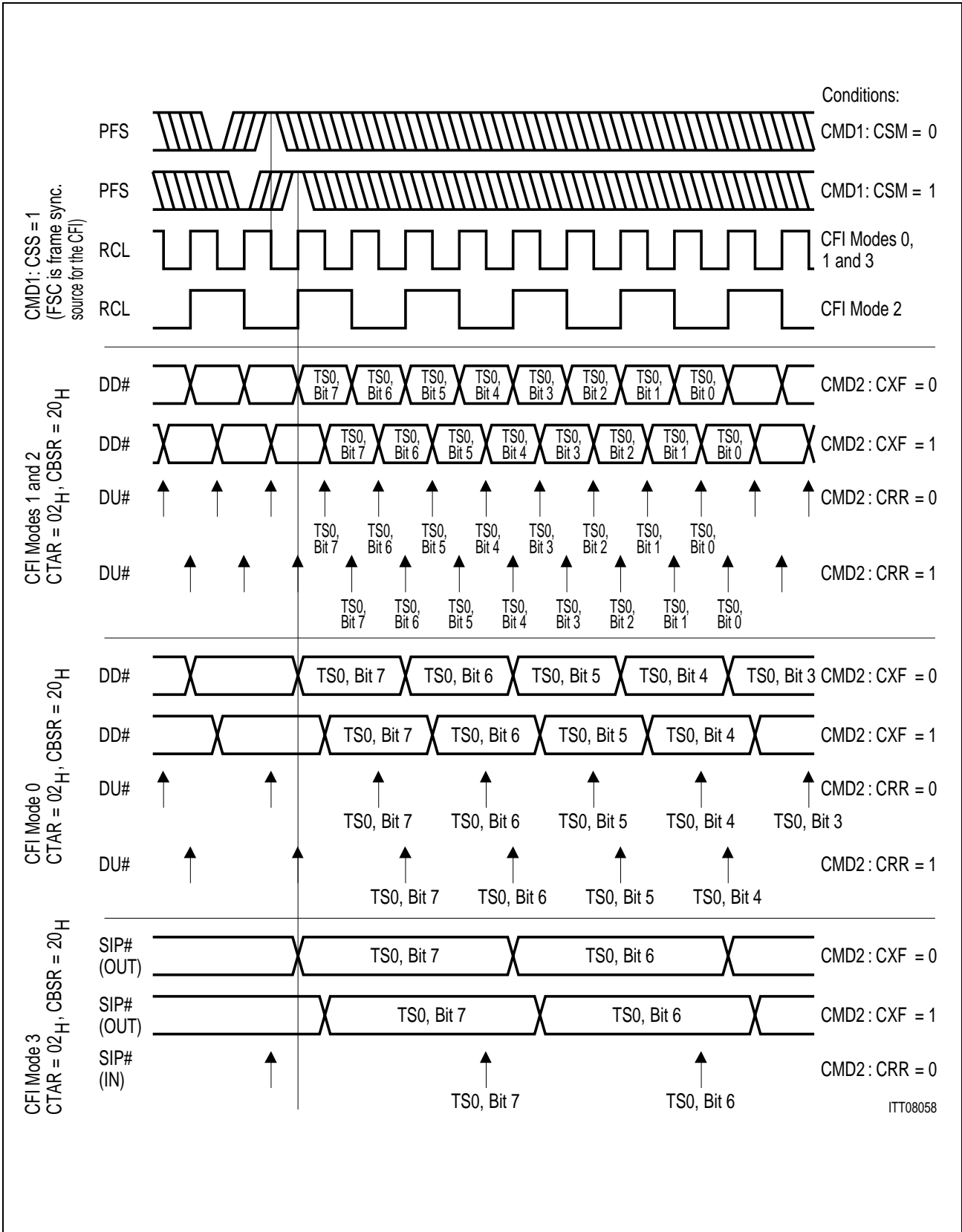

Figure 42
CFI Bit Timing with Respect to the Framing Signal PFS (CMD1:CSS = 0)



ITT08058

Figure 43
CFI Bit Timing with Respect to the Framing Signal FSC (CMD1:CSS = 1)

Examples

1) In CFI mode 0, with a frame consisting of 32 time slots, the following timing relationship between the framing signal source PFS and the data signals is required:

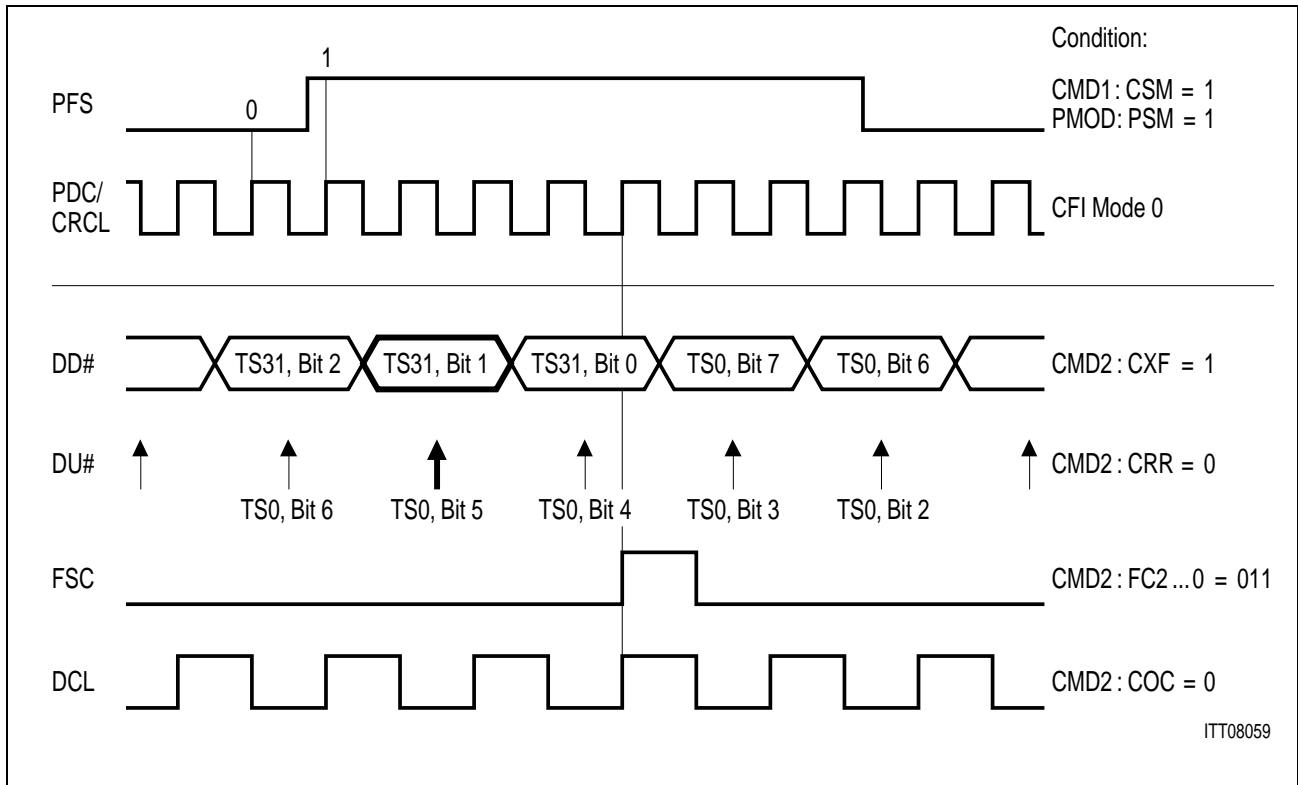

Figure 44
Timing Signals for CFI Bit Shift Example 1

The framing signal source PFS shall mark CFI time slot 31, bit 1 in downstream direction and CFI time slot 0, bit 5 in upstream direction. The data shall be transmitted and sampled with the falling CRCL edge. The timing of the FSC and DCL output signals shall be as shown in **figure 44**. The PFS signal is sampled with the rising PDC edge.

The following CFI register values result:

Since PFS marks the downstream bit 1, the CBSR:CDS bits must be set to “000”, according to **table 18**.

If the CBSR:CDS bits are set to “000”, PFS marks the time slot $TSN - 1$, according to **table 18**.

PFS shall mark CFI time slot 31, i.e. $TSN - 1 = 31$, or $TSN = 31 + 1 = (32)_{\text{mod } 32} = 0$

From this it follows that:

$CTAR:TSN6 \dots 0 = TSN + 2 = 0 + 2 = 2_D = 0000010_B$; i.e. $CTAR = 02_H$

The upstream CFI frame shall be shifted by 4 bits to the left (TS31, bit 1 + 4 bits yields in TS0, bit 5).

The CBSR:CUS bits must therefore be set to “0100”, according to **figure 41**.

The complete value for CBSR is: CBSR = 04_H

Finally, the CMD2 register bits must be set to

FC2 ... 0 = 011, COC = 0, CXF = 1, CRR = 0, CBN9 ... 8 = 00, i.e. CMD2 = 68_H

2) In CFI mode 0, with a frame consisting of 32 time slots, the following timing relationship between the framing signal source FSC and the data signals is required:

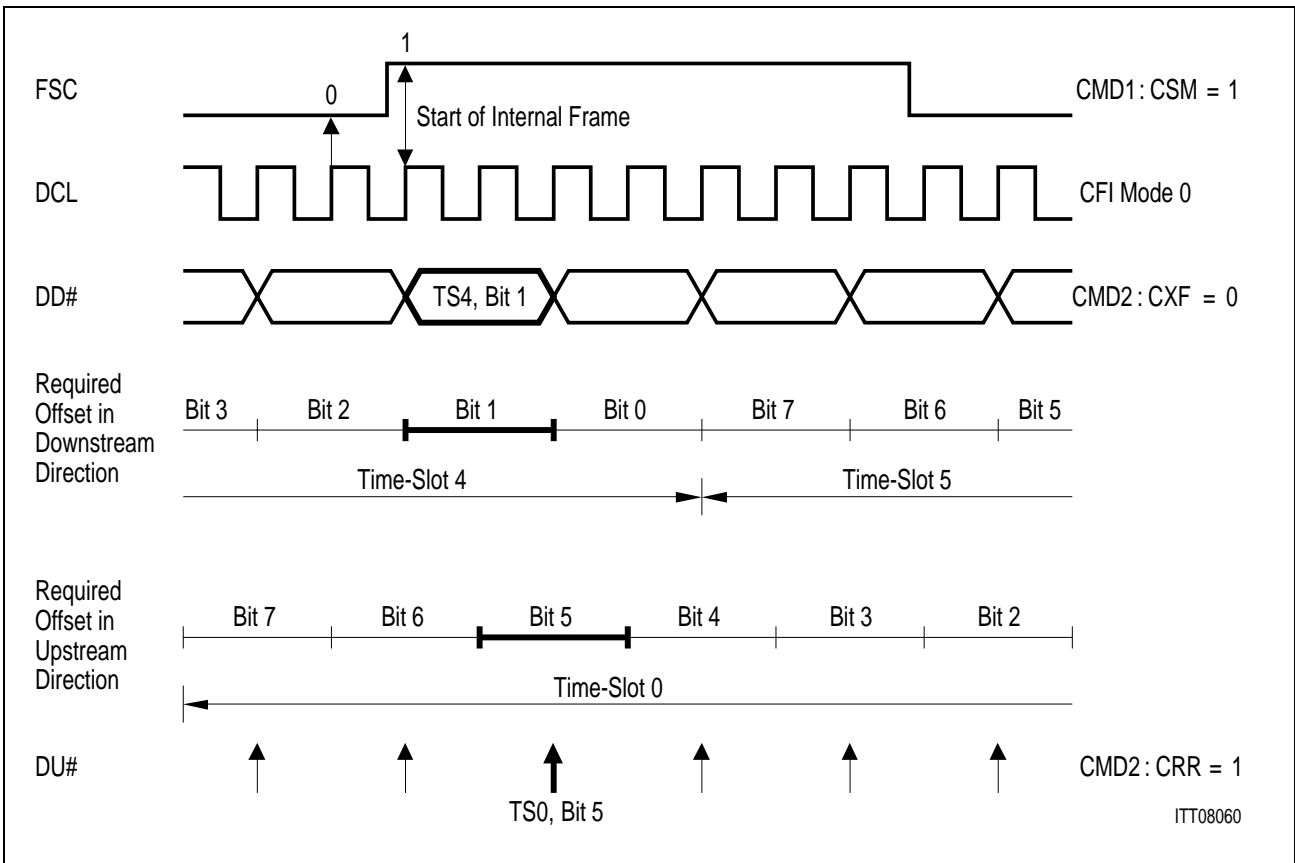

Figure 45
Timing Signals for CFI Bit Shift Example 2

The framing signal source FSC shall mark CFI time slot 4, bit 1 in downstream direction and CFI time slot 0, bit 5 in upstream direction. The data shall be transmitted with the rising CRCL edge and sampled with the rising CRCL edge. The FSC signal shall be sampled with the rising DCL edge.

The following CFI register values result:

Since FSC marks the downstream bit 1, the CBSR:CDS bits must be set to “000”, according to **table 18**.

If the CBSR:CDS bits are set to “000”, FSC marks the time slot TSN – 1, according to **table 18**.

FSC shall mark CFI time slot 4, i.e. TSN – 1 = 4, or TSN = 4 + 1 = 5

From this it follows that:

$CTAR:TSN6 \dots 0 = TSN + 2 = 5 + 2 = 7_D = 0000111_B$; i.e. $CTAR = 07_H$

The upstream CFI frame shall be shifted by 28 bits to the right (ts 4, bit 1 - 28 bits yields in TS0, bit 5)

Since it is not possible to shift the upstream frame with respect to the downstream frame by more than 15 bits when using the CCSR:CUS bits, the following trick must be used:

The CCSR:CUS bits are set to "0100" to shift the frame by 4 bits to the left. The remaining shift to the right of $28 + 4 = 32$ bits (equivalent to 4 time slots) can now be performed by renumbering the upstream CFI time slots in the software. This results in an offset of 4 time slots when addressing a CFI time slot via the Control Memory (CM):

If CFI time slot N shall be switched (N refers to the external time slot numbering), the CM must be written with the CFI address $(N + 4)_{\text{mod } 32}$.

If for example the upstream CFI time slot 0 of port 0 shall be switched to a PCM time slot, the CM address 88_H (CFI p 0, TS4) must be used.

The complete value for CCSR is: $CCSR = 04_H$

Finally the CMD2 register bits must be set to

$FC2 \dots 0 = XXX$, $COC = X$, $CXF = 0$, $CRR = 1$, $CBN9 \dots 8 = 00$, i.e.: $CMD2 = 04_H$

CFI Receive Line Selection CMD1:CIS1 ... CIS0

The CFI transmit line of a given logical port (as it is used for programming the switching function) is always assigned to a dedicated physical transmit pin, e.g. in CFI mode 1, pin DD1 carries the CFI data of logical port 1.

In receive direction however, an assignment between logical and physical ports can be made in CFI modes 1 and 2. This selection is programmed via the alternative input selection bits 1 and 0 (CIS1, CIS0) in the CMD1 register.

In CFI mode 0 and 3, CIS1 and CIS0 should both be set to 0.

In CFI mode 1, CIS0 selects between receive lines DU0 and DU2 for logical port 0 and CIS1 between the receive lines DU1 and DU3 for logical port 1.

In CFI mode 2, CIS0 selects between the receive lines DU0 and DU2, CIS1 should be set to 0.

Application Hints

Table 19 shows the function taken over by each of the CFI interface pins, depending on the CFI mode and the values programmed to CIS1 and CIS0.

Table 19

| CFI Mode | Port 0 | | Port 1 | | Port 2 | | Port 3 | |
|----------|-----------------|------|-----------------|--------|-----------------|--------|-----------------|--------|
| | DU0 | DD0 | DU1 | DD1 | DU2 | DD2 | DU3 | DD3 |
| 0 | IN0 | OUT0 | IN1 | OUT1 | IN2 | OUT2 | IN3 | OUT3 |
| 1 | IN0 CIS0 = 0 | OUT0 | IN1 CIS1 = 0 | OUT1 | IN0 CIS0 = 1 | high Z | IN1 CIS1 = 1 | high Z |
| 2 | IN CIS0 = 0 | OUT | – | high Z | IN CIS0 = 1 | high Z | – | high Z |
| 3 | I/O4 | I/O0 | I/O5 | I/O1 | I/O6 | I/O2 | I/O7 | I/O3 |

Figure 46 shows the correlation between physical and logical CFI ports in CFI modes 0, 1, 2 and 3:

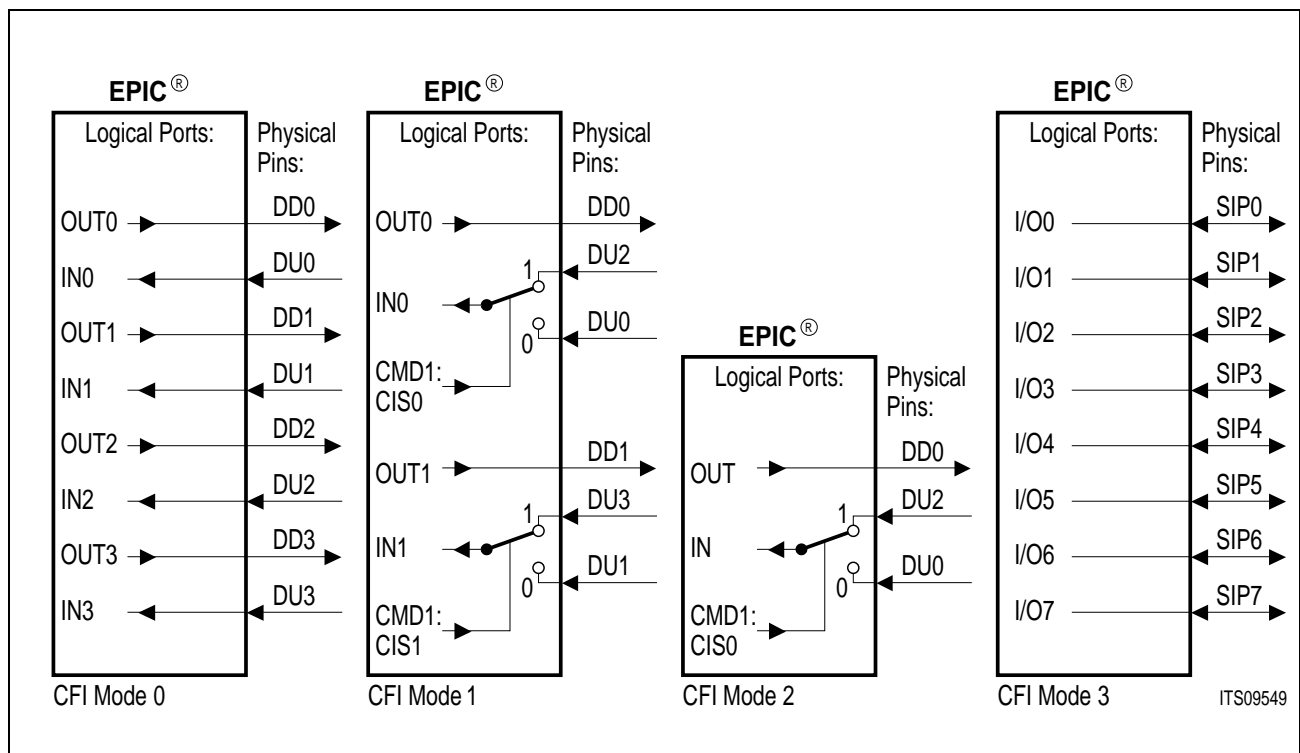

Figure 46
Correlation Between Physical and Logical CFI Ports

CFI subtime Slot Position CSCR

If a time slot assignment is programmed in the control memory (CM), the used control memory code defines the channel bandwidth and the subchannel position at the PCM interface (refer to **chapter 5.4.2**). The subchannel position at the configurable interface however is defined on a per port basis in the Configurable interface SubChannel Register CSCR.

The subchannel control bits SC#1 ... SC#0 specify separately for each logical port the bit positions to be exchanged with the data memory (DM) when a connection with a channel bandwidth as defined by the CM code has been established:

Table 20

| SC#1 | SC#0 | Bit Positions for CFI Subchannels Having a Bandwidth of | | |
|------|------|---|-----------|-----------|
| | | 64 kbit/s | 32 kbit/s | 16 kbit/s |
| 0 | 0 | 7 ... 0 | 7 ... 4 | 7 ... 6 |
| 0 | 1 | 7 ... 0 | 3 ... 0 | 5 ... 4 |
| 1 | 0 | 7 ... 0 | 7 ... 4 | 3 ... 2 |
| 1 | 1 | 7 ... 0 | 3 ... 0 | 1 ... 0 |

Table 21 shows the effect of the different subchannel control bits SC#1 ... SC#0 on the CFI ports in each CFI mode:

Table 21

| SC#1 | SC#0 | CFI Mode | | | |
|------|------|----------|----------|----------|---------------|
| | | 0 | 1 | 2 | 3 |
| SC01 | SC00 | port 0 | port 0 | port | ports 0 and 4 |
| SC11 | SC10 | port 1 | port 1 | see note | ports 1 and 5 |
| SC21 | SC20 | port 2 | see note | see note | ports 2 and 6 |
| SC31 | SC30 | port 3 | see note | see note | ports 3 and 7 |

*Note: In CFI mode 1: SC21 = SC01; SC20 = SC00; SC31 = SC11; SC30 = SC10
In CFI mode 2: SC31 = SC21 = SC11 = SC01; SC30 = SC20 = SC10 = SC00*

If for example at CFI port 1 a 16 kbit/s channel shall be switched to (or from) a CFI bit position 5 ... 4 from (or to) any 2 bit subtime slot position at the PCM interface, a CM code defining a channel bandwidth of 16 kbit/s and defining the subchannel position at the PCM interface must be written to the CM code field of the involved 8 bit CFI time slot (i.e. 0111, 0110, 0101 or 0100). In order to insert (or extract) bit positions 5 ... 4 of the selected 8 bit CFI time slot, SC11 ... SC10 have to be set to 01. Once fixed to this value, all time slot connections programmed on CFI port 1 are performed on bits 7 ... 0 for 64 kbit/s channels, bits 3 ... 0 for 32 kbit/s channels and bits 5 ... 4 for 16 kbit/s channels.

Since for each CFI time slot there is only one control memory location, only one subchannel may be mapped to each CFI time slot. The remaining bits of such a partly unused CFI time slot are inactive e.g. set to high impedance if OMDR: COS = 0.

Note that if an odd numbered CFI time slot is initialized as an IOM channel with switched D channel, SC#1 ... SC#0 must be set to "00" because the D channel is located at bits 7 ... 6. In this case the remaining bits can still be used for C/I and monitor channel applications (refer to **chapter 5.5**).

For more detailed information on subchannel switching refer to **chapter 5.4.2**.

CFI Standby Mode OMDR:CSB

In standby mode (OMDR:CSB = 0), the CFI output ports are set to high impedance and the clock signals DCL and FSC, if programmed as outputs (CMD1:CSS = 0), are switched off.

Note that the internal operation of the EPIC is not affected in standby mode, i.e. the received CFI data is still read in and may still be processed by the EPIC (switched to PCM or μ P, etc.)

In operational mode (OMDR:CSB = 1), the CFI output pins take over the function programmed in the control memory and DCL and FSC deliver clock and framing output signals (if CMD1:CSS = 0) as programmed in CMD1 and CMD2.

CFI Output Driver Selection OMDR: COS

The output drivers at the configurable interface (DD# or I/O#) can be programmed as open drain or tristate drivers.

If programmed as open drain drivers (OMDR: COS = 1), external pull-up resistors (connected to V_{DD}) are required in order to pull the output line to a high level if a logical 1 is being transmitted. For unassigned channels (e.g. control memory code "0000") the EPIC transmits a logical 1. The maximum output current at a low voltage level of 0.45 V is 7 mA, pull-up resistors down to 680 Ω can thus be used.

If programmed as tristate drivers (OMDR: COS = 0), logical 0s and 1s are transmitted with push-pull output drivers, whereas unassigned channels are set to high impedance.

5.3 Data and Control Memories

5.3.1 Memory Structure

The EPIC memory is composed of the **Control Memory (CM)** and the **Data Memory (DM)**. Their structure is shown in **figure 47**.

The **control memory** refers to the Configurable Interface (CFI) such that for each CFI time slot and for each direction (upstream and downstream) there is a 4 bit code field and an 8 bit data field location.

The code field defines the function of the corresponding CFI time slot. A time slot, may for example, be transparently switched through to the PCM interface (switched channel) or it may serve as monitor, feature control, command/indication or signaling channel in an IOM or SLD application (preprocessed channel) or it may be directly switched to the μ P interface (μ P channel).

The use of the data field depends on the function defined by the code field. If a CFI time slot is defined as a switched channel, the data field is interpreted as a pointer to the data memory and defines therefore to which PCM time slot the connection shall be made. For preprocessed channels, the data field serves as a buffer for the command/indication or signaling value. If a μ P channel is programmed, the data field content is directly exchanged with the CFI time slot.

The **data memory** refers to the PCM interface such that for each upstream time slot there is a 4 bit code field and an 8 bit data field location, whereas for each downstream time slot there is only an 8 bit data field location.

The data field locations buffer the PCM data transmitted and received over the PCM interface. The code field (tristate field) defines whether the upstream data field contents should be transmitted in the associated PCM time slot or whether the time slot should be switched to high impedance.

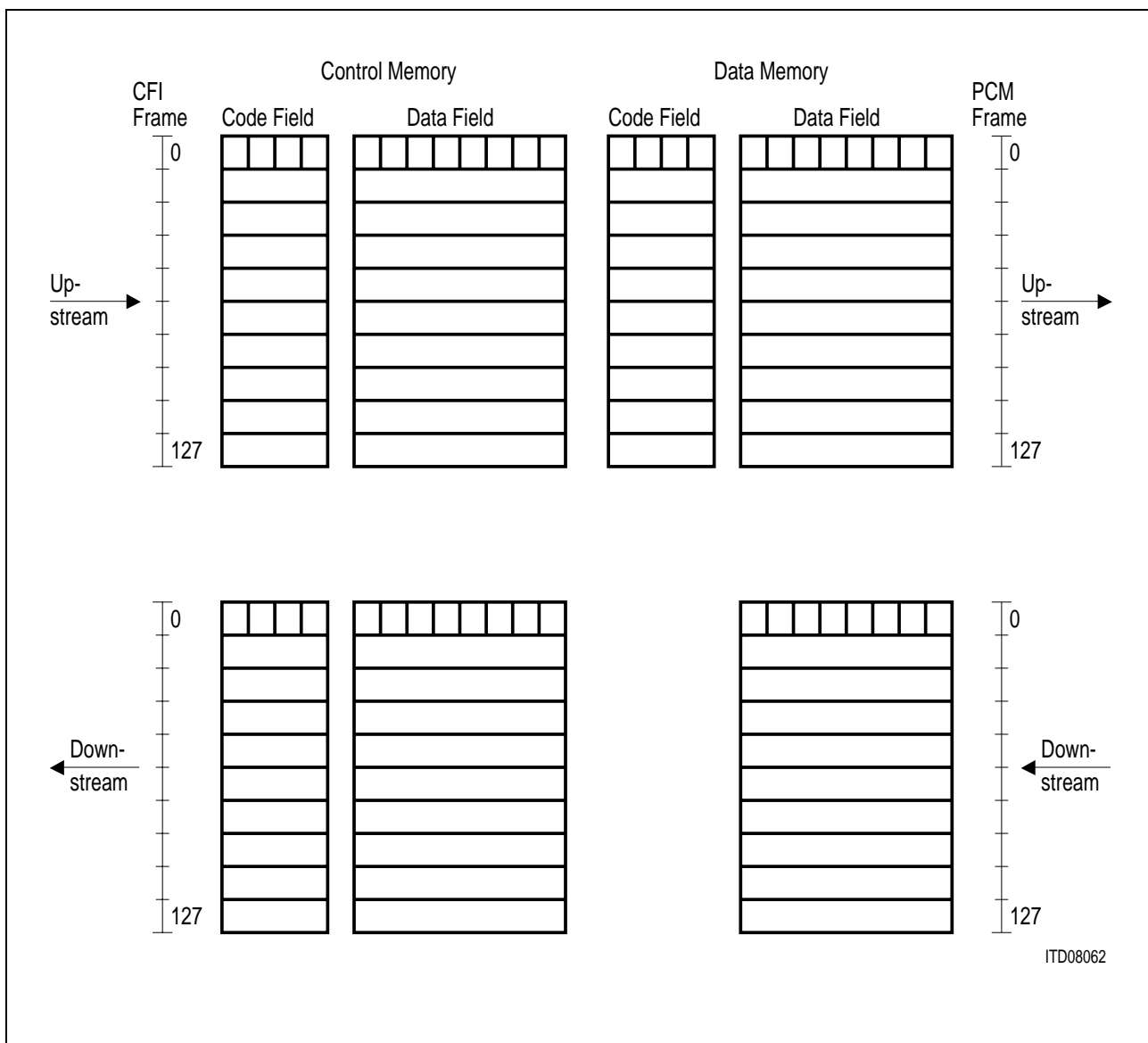

ITD08062

Figure 47
EPIC® Memory Structure

5.3.2 Indirect Register Access

The control and data memories must be accessed by the μ P in order to initialize the CFI and PCM interfaces for the required functionality, to program time slot assignments, to access the control/signaling channels (IOM/SLD), etc.

This access is performed through indirect addressing using the **memory access registers MADR, MAAR, and MACR**.

Application Hints

Memory Access Data Register read/write reset value: undefined



The **Memory Access Data Register MADR** contains the data to be transferred from or to a memory location. The meaning and the structure of this data depends on the kind of memory being accessed. If, for example, MADR contains a pointer to a PCM time slot, the data must be encoded according to **figure 48**. If it contains a 4 bit C/I code the structure would for example be “11 C/I 11”. For accesses to 4 bit code fields only the 4 least significant bits of MADR are relevant.

Memory Access Address Register read/write reset value: undefined

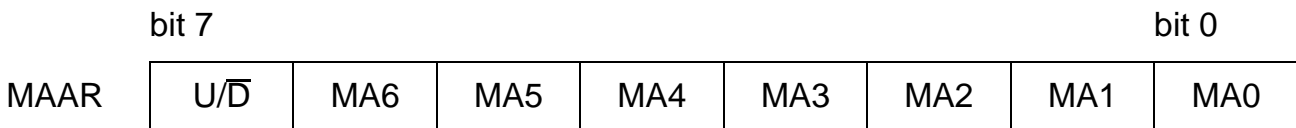

The **Memory Access Address Register MAAR** specifies the address of the memory access. This address encodes a CFI time slot for control memory and a PCM time slot for data memory accesses. Bit 7 of MAAR (U/ \bar{D} bit) selects between upstream and downstream memory blocks.

Bits MA6 ... 0 encode the CFI or PCM port and time slot number according to **figure 48**.

Memory Access Control Register read/write reset value: undefined

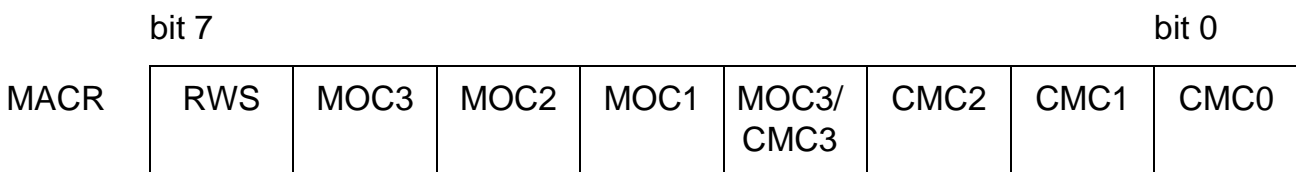

The **Memory Access Control Register MACR** selects the type of memory (control or data memory), the type of field (data or code field) and the access mode (read or write) of the register access. When writing to the control memory code field, MACR also contains the 4 bit code (CMC3 ... 0) defining the function of the addressed CFI time slot.

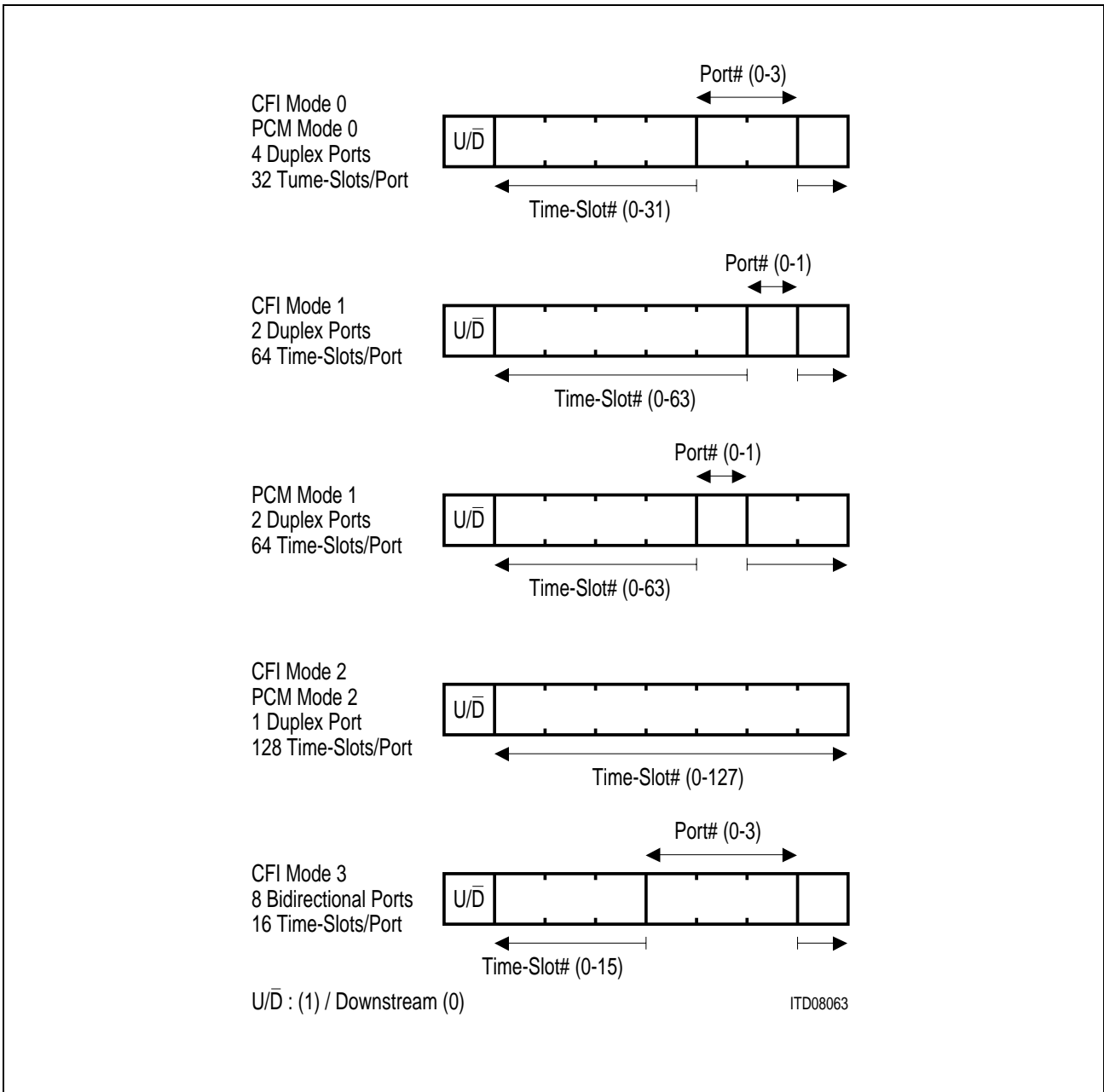

Figure 48
Time Slot Encoding for the Different PCM and CFI Modes

Memory Access Time

Writing to MACR starts a memory write or read operation which takes a certain time. During this time no further memory accesses may be performed i.e. the MADR, MAAR, and MACR registers may not be written. The STAR:MAC bit indicates whether a memory operation is still in progress (MAC = 1) or already completed (MAC = 0) and should therefore be interrogated before each access.

5.3.3 Memory Access Commands

The memory access commands can be divided into the following four categories:

- Access to the Data Memory Data Field: μ P access to PCM frame
- Access to the Data Memory Code Field: PCM tristate control
- Access to the Control Memory Data Field: time slot assignment, μ P access to CFI frame
- Access to the Control Memory Code Field: set-up of CFI time slot functionality

In the following chapters, these commands are explained in more detail.

5.3.3.1 Access to the Data Memory Data Field

The data memory (DM) data field buffers the PCM data transmitted (upstream block) and received (downstream block) via the PCM interface. Normally this data is switched transparently from or to the CFI and there is no need to access it from the μ P interface. For some applications however it is useful to have a direct μ P access to the PCM frame.

When an upstream PCM time slot (or even subtime slot) is not switched from the CFI (unassigned channel), it is possible to write a fixed value to the corresponding DM data field location. This value will then be transmitted repeatedly in each PCM frame without further μ P interaction (PCM idle code). If instead a continuous pattern should be sent, the write access can additionally be synchronized to the frame by means of synchronous transfer interrupts (see **chapter 5.7**).

Writing to an upstream DM data field location can also be restricted to a 2 or 4 bit subtime slot. It is thus possible to have certain subtime slots of the same 8 bit time slot switched from the CFI with the other subtime slots containing a PCM idle code. This restriction is made via the Memory Operation Code (refer to **table 22**).

For test purposes the upstream DM data field contents can also be read back.

The downstream DM data field cannot be written to, it can only be read. Reading such a location reflects the PCM data contained in the received PCM frame regardless of a connection to the CFI having been established or not. The μ P can thus determine the contents of received PCM time slots simply by reading the corresponding downstream DM locations. This reading can, if required, also be synchronized to the frame by means of synchronous transfer interrupts.

The Procedure for Writing to the Upstream DM Data Field is

W:MADR = value to be transmitted in the PCM (sub)time slot

W:MAAR = address of the desired (upstream)¹⁾ PCM time slot encoded according to **figure 48**

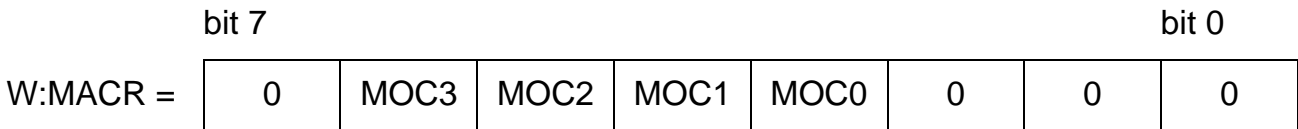

MOC3 ... 0 defines the bandwidth and the position of the subchannel according to **table 22**.

Table 22

| MOC3 ... 0 | Transferred Bits | Channel Bandwidth |
|------------|------------------|-------------------|
| 0000 | – | – |
| 0001 | bits 7 ... 0 | 64 kbit/s |
| 0011 | bits 7 ... 4 | 32 kbit/s |
| 0010 | bits 3 ... 0 | 32 kbit/s |
| 0111 | bits 7 ... 6 | 16 kbit/s |
| 0110 | bits 5 ... 4 | 16 kbit/s |
| 0101 | bits 3 ... 2 | 16 kbit/s |
| 0100 | bits 1 ... 0 | 16 kbit/s |

The Procedure for Reading the DM Data Field is

W:MAAR = address of the desired PCM time slot encoded according to **figure 48**

W:MACR = 1000 0000_B = 80_H²⁾

wait for STAR:MAC = 0

R:MADR = value

Figure 49 illustrates the access to the Data Memory Data Field.

¹⁾ The U/D bit of MAAR will implicitly be set to 1.

²⁾ When reading a DM data field location, all 8 bits are read regardless of the bandwidth selected by the MOC bits.

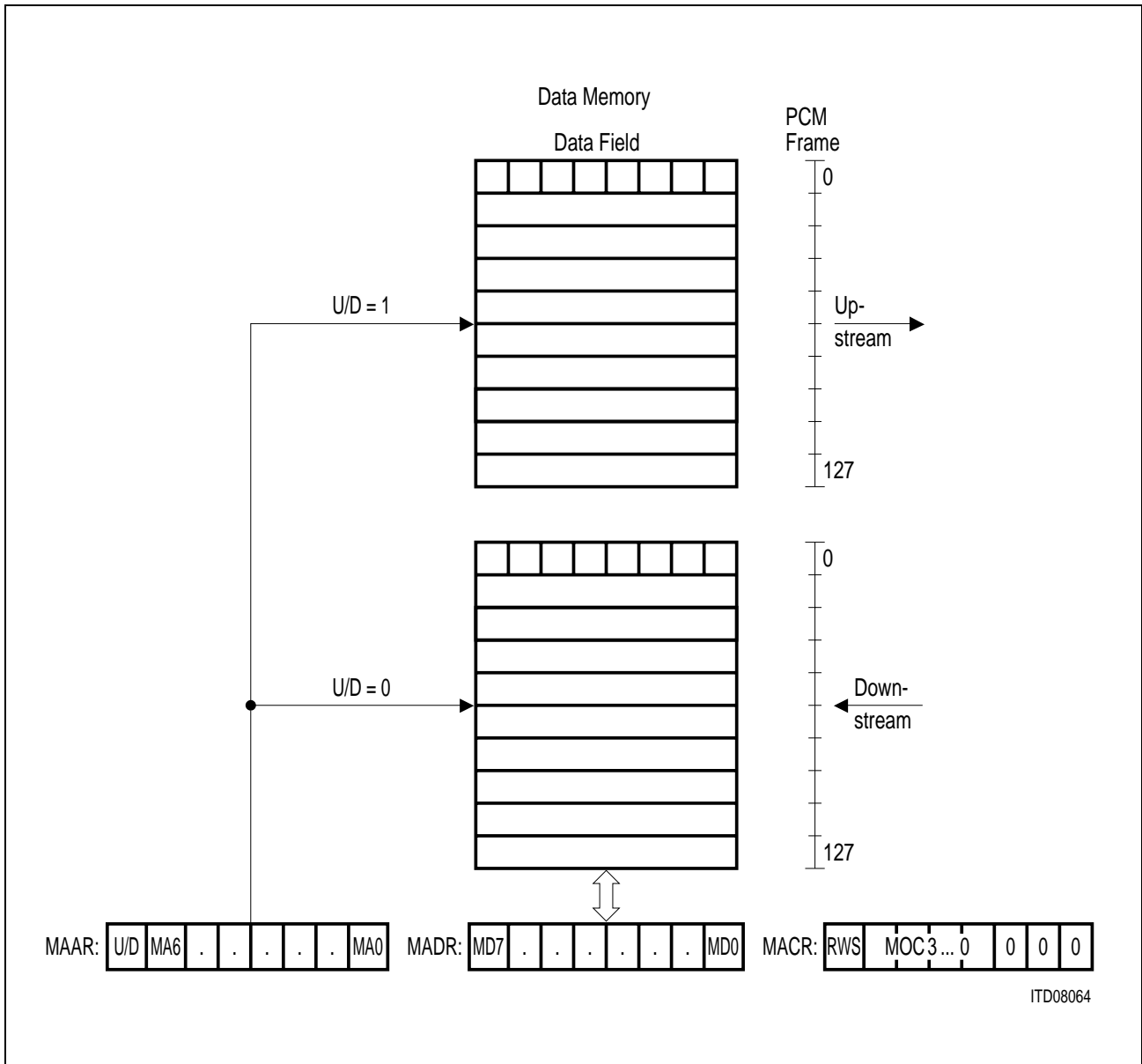

ITD08064

Figure 49
Access to the Data Memory Data Field

Examples

In PCM mode 0 the idle code “1010 0101_B” shall be transmitted in time slot 16 of port 0:

W:MADR = 1010 0101_B ; idle code

W:MAAR = 1100 0000_B ; address of upstream PCM time slot 16 of port 0
according to **figure 48**

W:MACR = 0000 1000_B ; write access, MOC code “0001”

The idle code can, of course, only be transmitted on the TxD# line if the corresponding tristate bits are enabled (refer to **chapter 5.3.3.2**):

W:MADR = XXXX 1111_B ; all 8 bits of addressed time slot to low impedance

W:MAAR = 1100 0000_B ; address of upstream PCM time slot 16 of port 0
according to **figure 48**

W:MACR = 0110 0000_B ; write access, MOC code “1100”

For test purposes the idle code can also be read back:

W:MAAR = 1100 0000_B ; address of upstream PCM time slot 16 of port 0
according to **figure 48**

W:MACR = 10XX X000_B ; read access, MOC code “0XXX”

wait for STAR:MAC = 0

R:MADR = 1010 0101_B ; idle code

In PCM mode 2 the idle pattern “0110” shall be transmitted in bit positions 3 ... 0 of time slot 63, bits 7 ... 4 shall be tristated:

W:MADR = XXXX 0110_B ; idle code

W:MAAR = 1011 1111_B ; address of upstream PCM time slot 63
according to **figure 48**

W:MACR = 0001 0000_B ; write access, MOC code “0010”

Programming of the desired tristate functions:

W:MADR = XXXX 0011_B ; bits 7 ... 4 to high impedance, bits 3 ... 0 to low impedance

W:MAAR = 1011 1111_B ; address of upstream PCM time slot 63
according to **figure 48**

W:MACR = 0110 0000_B ; write access, MOC code “1100”

5.3.3.2 Access to the Data Memory Code (Tristate) Field

The data memory code field exists only for the upstream DM block and is also called the PCM tristate field. Each (sub)time slot of each PCM transmit port can be individually tristated via these code field locations.

If a (sub)time slot is set to low impedance, the contents of the corresponding DM data field location is transmitted with a push-pull driver onto the transmit port TxD# and the tristate control line $\overline{TSC\#}$ is pulled low for the duration of that (sub)time slot.

If a (sub)time slot is set to high impedance, the transmit port TxD# will be tristated and the $\overline{TSC\#}$ line is pulled high for the duration of that (sub)time slot.

There are 4 code bits for selecting the tristate function of each 8 bit time slot i.e. 1 control bit for each 16 kbit/s (2 bits) subtime slot. If a control bit is set to 1, the corresponding subtime slot is set to low impedance, if it is set to 0 the subtime slot is tristated.

Figure 50 illustrates this behavior.

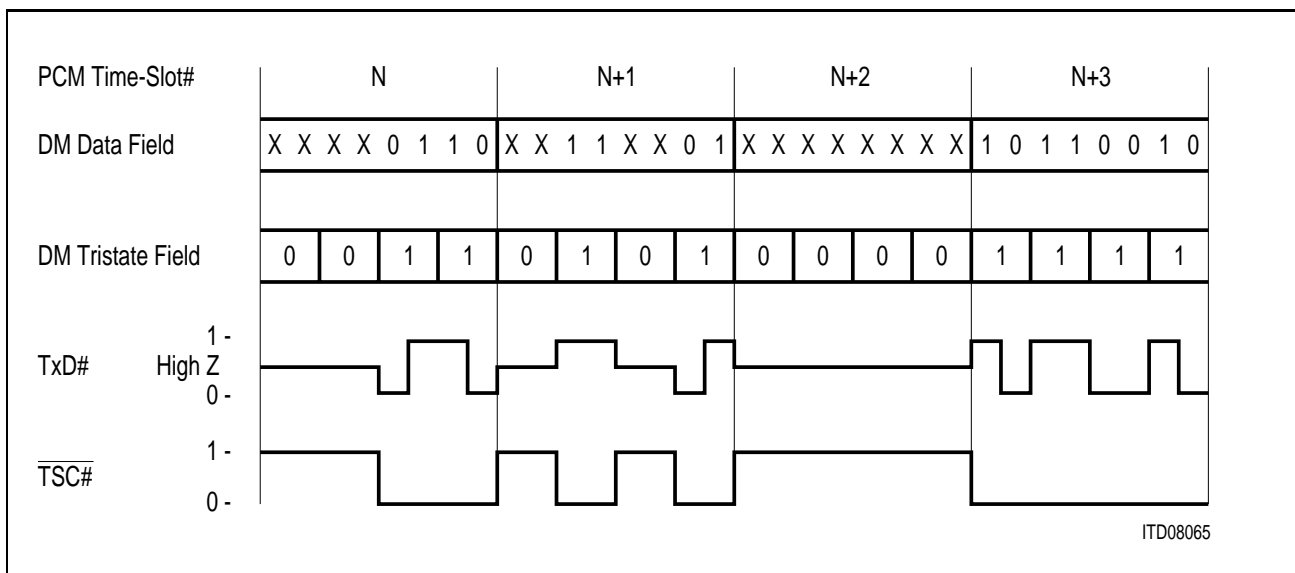

Figure 50
Tristate Control at the PCM Interface

The tristate field can be written to and, for test purposes, also be read back.

There are two commands (Memory Operation Codes) for accessing the tristate field:

With the “**Single Channel Tristate Control**” command (MOC3 ... 0 = 1100) the tristate field of a single PCM time slot can be written to and also read back. The 4 least significant bits of MADR are exchanged with the code field of the time slot selected by the MAAR register.

With the “**Tristate Control Reset**” command (MOC3 ... 0 = 1101) the tristate field of all PCM time slots can be written to with a single command. The 4 bits of MADR are then copied to all code field locations regardless of the address programmed to MAAR. Such a complete access to the DM tristate field takes 1035 RCL cycles.

The MADR bits MD7 ... MD0 control the PCM time slot bit positions 7 ... 0 in the following way:

MD7 ... MD4 are not used (don't care);

MD3 ... MD0 select between the states high impedance (MD# = 0) or low impedance (MD# = 1)

| | | | | | | | | |
|-------------------------|-----|---|-----|---|-----|---|-----|---|
| time slot Bit Position: | 7 | 6 | 5 | 4 | 3 | 2 | 1 | 0 |
| MADR Bits: | MD3 | | MD2 | | MD1 | | MD0 | |

The Procedure for Writing to a Single PCM Tristate Field is

W:MADR = X X X X MD3 MD2 MD1 MD0_B

W:MAAR = address of the desired (upstream)¹⁾ PCM time slot according to **figure 48**

W:MACR = 0110 000_B = 60_H

The Procedure for Reading Back a (Single) PCM Tristate Field Location is

W:MAAR = address of the desired (upstream)¹⁾ PCM time slot according to **figure 48**

W:MACR = E0_H

wait for STAR:MAC = 0

R:MADR = X X X X MD3 MD2 MD1 MD0_B

The Procedure for Writing to all PCM Tristate Field Positions is

W:MADR = X X X X MD3 MD2 MD1 MD0_B

W:MACR = 0110 1000_B = 68_H

¹⁾ The U/ \bar{D} bit of MAAR will implicitly be set to 1.

Figure 51 illustrates the access to the tristate field:

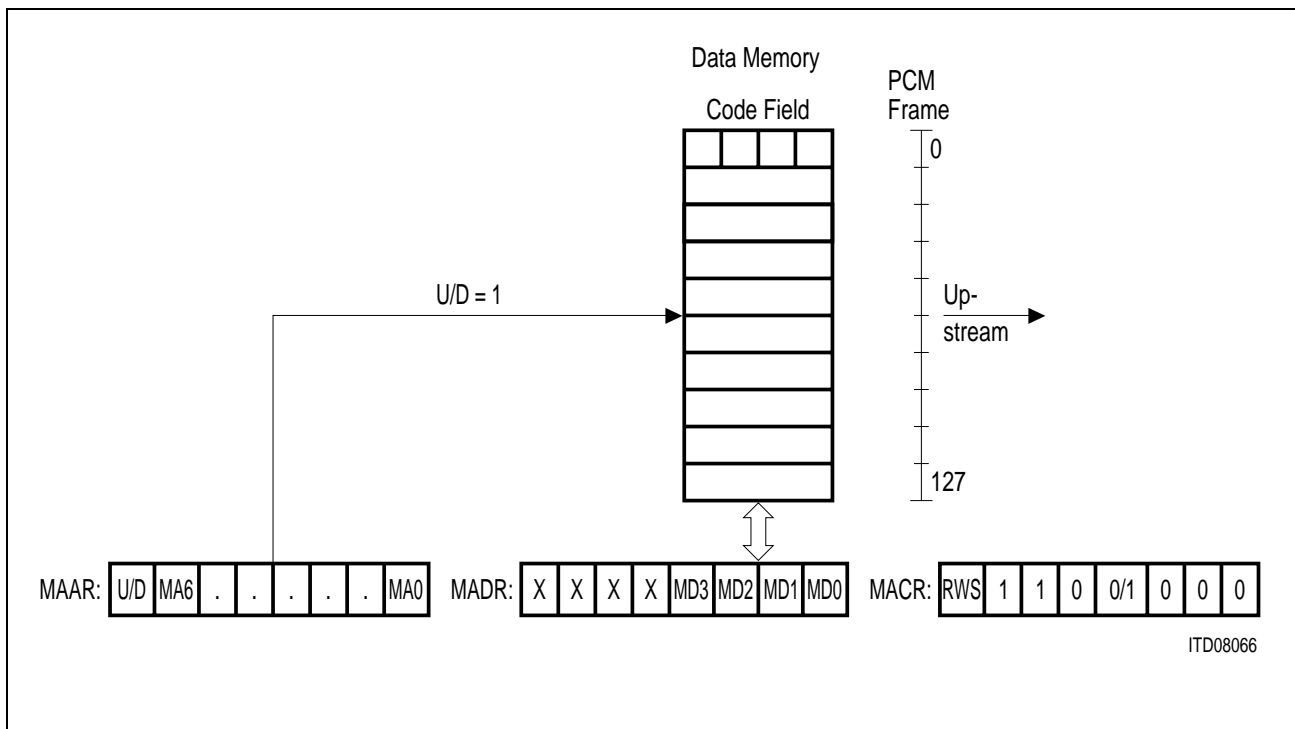

Figure 51
Access to the Data Memory Code (Tristate) Field

Examples

All PCM time slots shall be set to high impedance (disabled):

W:MADR = 00_H ; all bits to high impedance
W:MACR = 68_H ; write access with MOC = 1101

All PCM time slots shall be set to low impedance (enabled):

W:MADR = FF_H ; all bits to low impedance
W:MACR = 68_H ; write access with MOC = 1101

In PCM mode 1, bits 7 ... 6 and 1 ... 0 of PCM port 1, time slot 10 shall be set to low impedance, bits 5 ... 2 to high impedance:

W:MADR = 0000 1001_B ; bits 7 ... 6 and 1 ... 0 to low impedance, bits 5 ... 2 to high impedance
W:MAAR = 1010 1010_B ; address of upstream PCM port 1, time slot 10 according to **figure 48**
W:MACR = 0110 0000_B ; write access with MOC = 1100

For test purposes this setting shall be read back:

W:MAAR = 1010 1010_B ; address of upstream PCM port 1, time slot 10
according to **figure 48**

W:MACR = 1110 0000_B = E0_H; read access with MOC = 1100
wait for STAR:MAC = 0

R:MADR = XXXX 1001_B ; read back of MD3 ... 0

5.3.3.3 Access to the Control Memory Data Field

Writing to or reading the control memory (CM) data field may serve different purposes depending on the function given to the corresponding CFI time slot which is defined by the 4 bit code field value:

Table 23

| CFI Time Slot Application | Meaning of CM Data Field |
|----------------------------------|---------------------------------|
| Switched channel | Pointer to PCM interface |
| Preprocessed channel | C/I or SIG value |
| μP channel | CFI idle code |

There are two types of commands which give access to the CM data field:

The memory operation code MACR:MOC = 111X is used for writing to the CM data field and code field simultaneously. The MADR content is transferred to the data field while the MACR:CMC3 ... 0 bits are transferred to the code field. This command is explained in more detail in **chapter 5.3.3.4**.

The memory operation code MACR:MOC = 1001 is used for reading or writing to the CM data field. Since the CM code field is not affected, this command makes only sense if the related CFI time slot has already the desired functionality.

The Procedure for Writing to the CM Data Field (using the MOC = 1001 command) is

W:MADR = value
W:MADR = CFI time slot address according **figure 48**
R:MADR = 0100 1000_B = 48_H

The Procedure for Reading the CM Data Field is

W:MAAR = CFI time slot address according **figure 48**
W:MACR = 1100 1000_B = C8_H
wait for STAR:MAC = 0
R:MADR = value

Figure 52 illustrates this behavior.

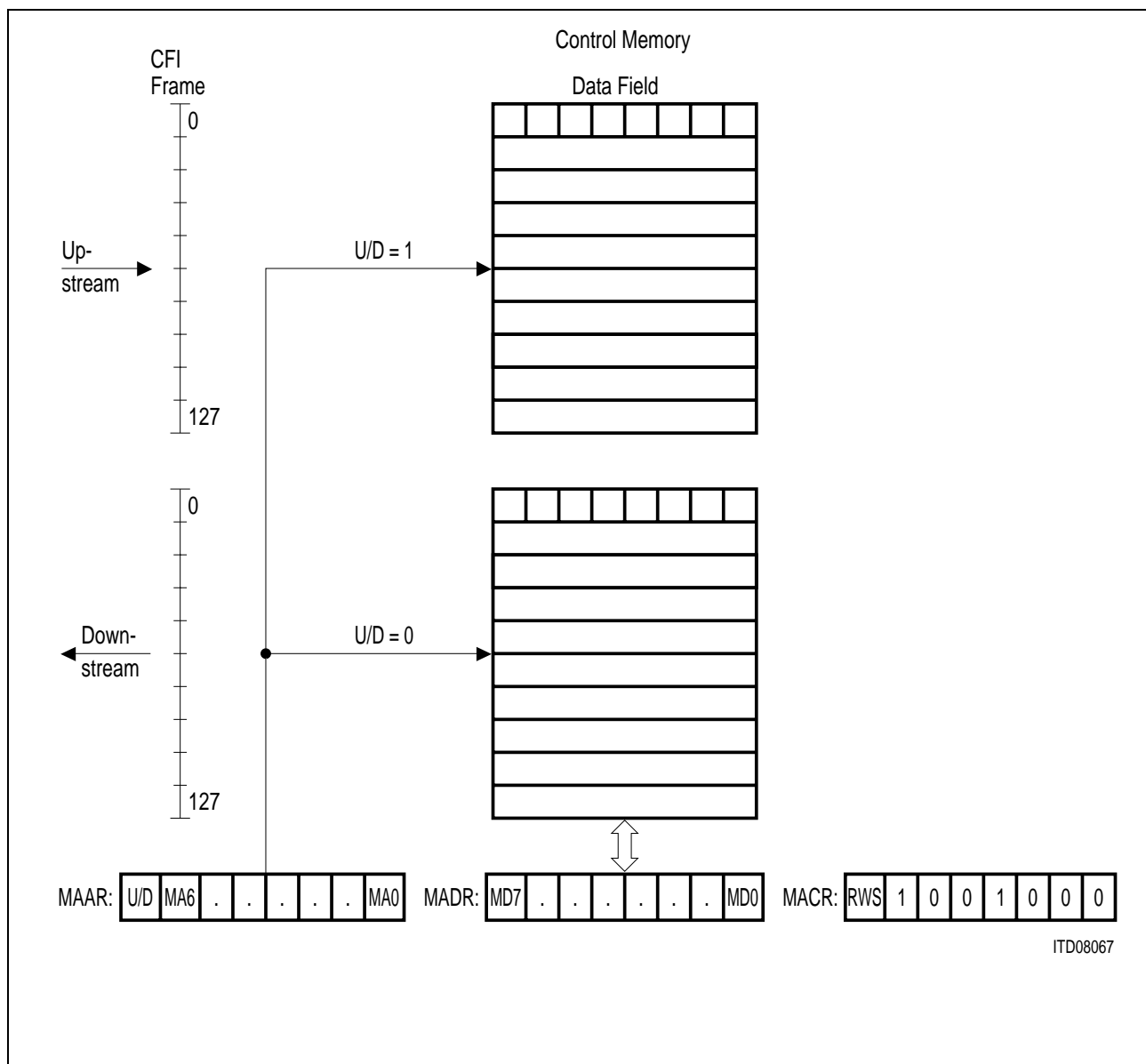

ITD08067

Figure 52
Access to the Control Memory Data Field

Examples

In CFI mode 2, CFI time slot 123 has been initialized as a switched channel. The CM data field value therefore represents a pointer to the PCM interface.

In a first step, the involved upstream and downstream PCM time slots shall be determined:

W:MAAR = 1111 1011_B ; address of upstream CFI time slot 123

W:MACR = 1100 1000_B ; read back command

wait for STAR:MAC = 0

R:MADR = value ; encoded according **figure 48**

W:MAAR = 0111 1011_B ; address of downstream CFI time slot 123

W:MACR = 1100 1000_B ; read back command

wait for STAR:MAC = 0

R:MADR = value ; encoded according **figure 48**

In the next step a new time slot assignment (to PCM port 1, time slot 34, PCM mode 1) shall be made for the upstream connection:

W:MADR = 1100 0110_B ; upstream PCM time slot 34, port 1

W:MAAR = 1111 1011_B ; address of upstream CFI time slot 123

W:MACR = 0100 1000_B ; write command

5.3.3.4 Access to the Control Memory Code Field

The 4 bit code field of the control memory (CM) defines the functionality of a CFI time slot and thus the meaning of the corresponding data field.

There are codes for switching applications, preprocessed applications and for direct μ P access applications (see **table 24**).

This 4 bit code, written to the MACR:CMC3 ... 0 bit positions, will be transferred to the CM code field by selecting MACR:MOC = 111X. The 8 bit MADR value is at the same time transferred to the CM data field.

The Procedure for Writing to the CM Code and Data Fields with a Single Command is

W:MADR = value for data field

W:MAAR = CFI time slot address encoded according to **figure 48**

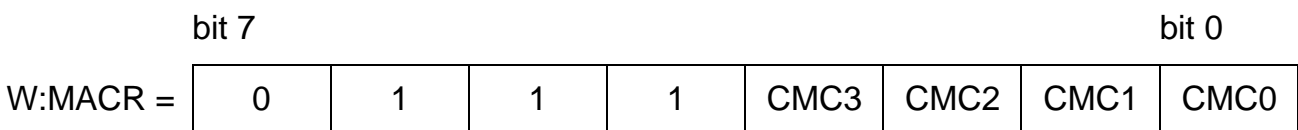

CMC3 ... 0 CM code, refer to **table 24**

Figure 53 illustrates this behavior.

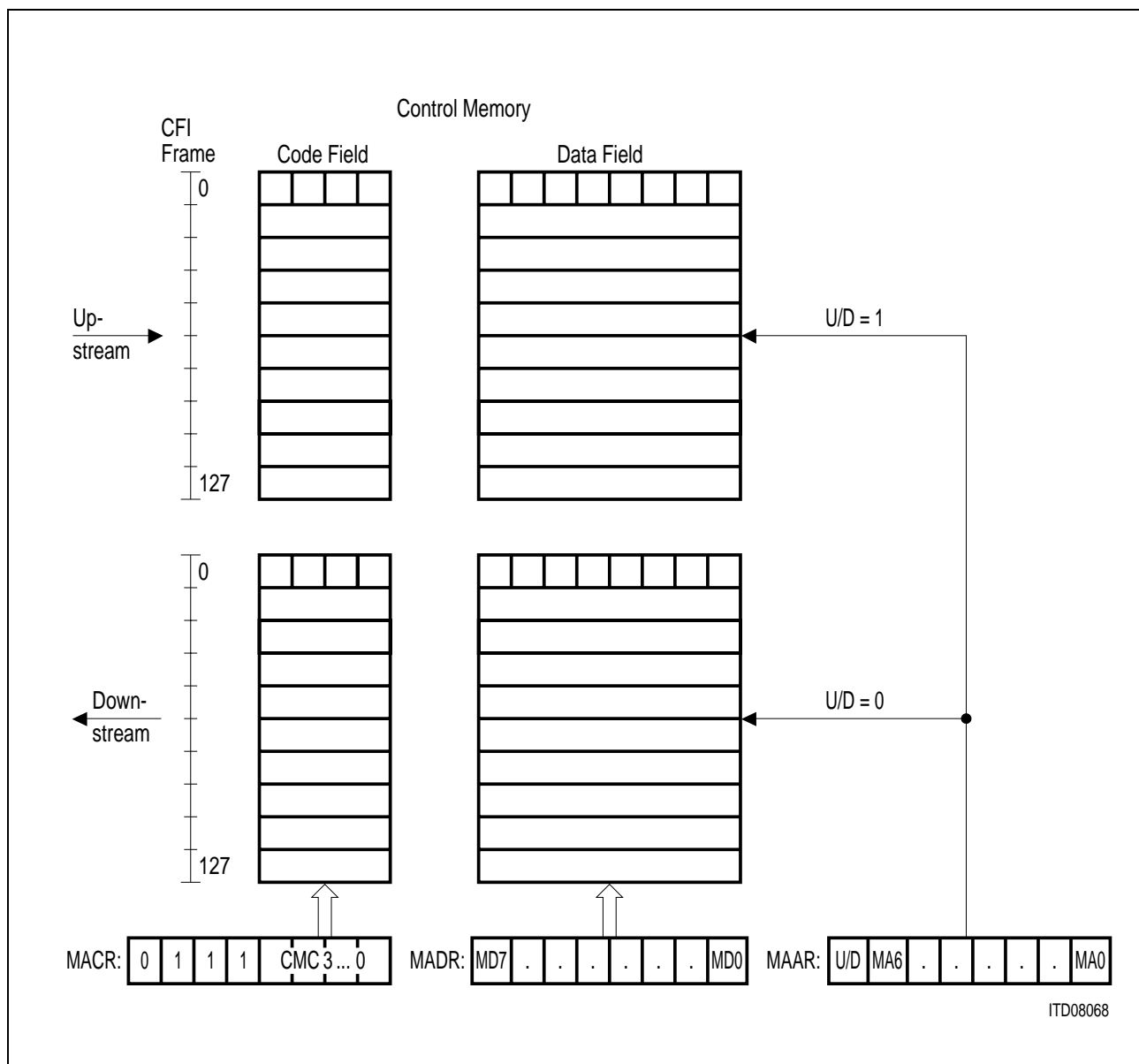

ITD08068

Figure 53
Write Access to the Control Memory Data and Code Fields

For reading back the CM code field, the command MACR:MOC = 111X is also used, the value of CMC3 ... 0 being don't care. The code field value can then be read from the lower 4 bits of MADR.

The Procedure for Reading the CM Code is

W:MAAR = CFI time slot address encoded according to **figure 48**

W:MACR = 1111 XXXX_B

wait for STAR:MAC = 0

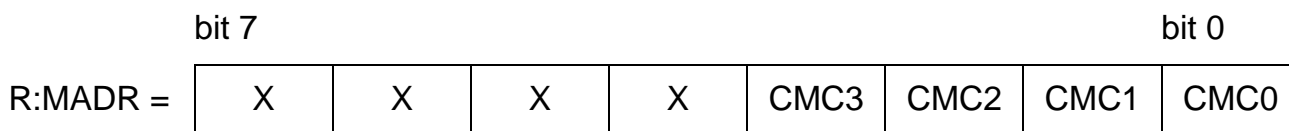

CMC3 ... 0: CM code, refer to **table 24**

Figure 54 illustrates this behavior.

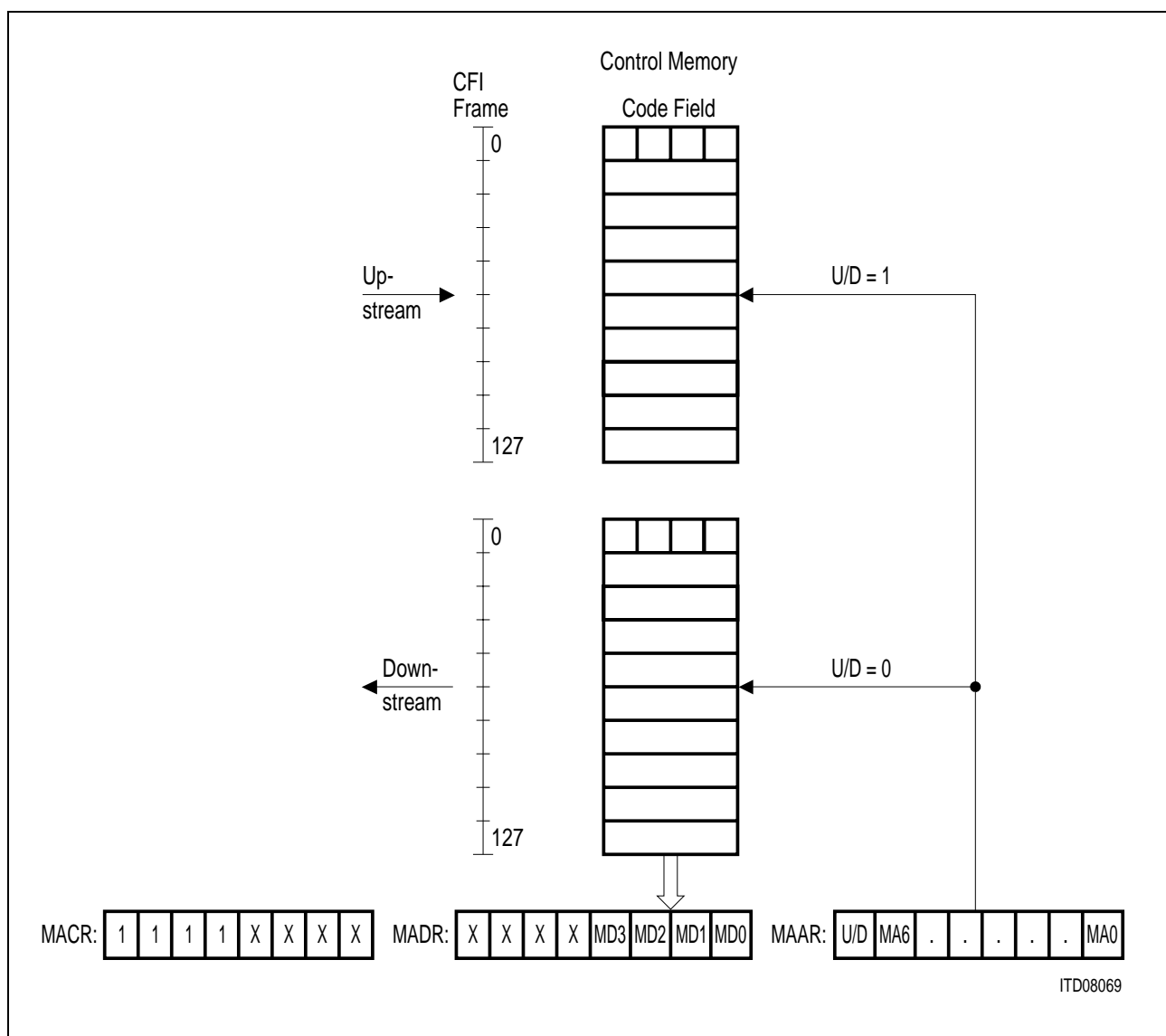

Figure 54
Read Access to the Control Memory Code Field

Table 24 shows all available Control Memory codes.

Table 24

| Application | CMC3 ... 0 | Transferred Bits | Channel Bandwidth |
|------------------------|------------|---|-------------------|
| Disable connection | 0000 | – | unassigned |
| Switched 8 bit channel | 0001 | bits 7 ... 0 | 64 kbit/s |
| Switched 4 bit channel | 0011 | bits 7 ... 4 | 32 kbit/s |
| Switched 4 bit channel | 0010 | bits 3 ... 0 | 32 kbit/s |
| Switched 2 bit channel | 0111 | bits 7 ... 6 | 16 kbit/s |
| Switched 2 bit channel | 0110 | bits 5 ... 4 | 16 kbit/s |
| Switched 2 bit channel | 0101 | bits 3 ... 2 | 16 kbit/s |
| Switched 2 bit channel | 0100 | bits 1 ... 0 | 16 kbit/s |
| Preprocessed channel | 1000 | refer to chapter 5.5 | |
| Preprocessed channel | 1010 | | |
| Preprocessed channel | 1011 | | |
| μP channel | 1001 | refer to chapter 5.6 and chapter 5.7 | |

Examples

In CFI mode 2, CFI time slot 123 shall be initialized as a switched channel. The CM data field value therefore represents a pointer to the PCM interface.

In a first step, a time slot assignment to PCM port 1, time slot 34 (PCM mode 1) shall be made for a 64 kbit/s upstream connection:

W:MADR = 1100 0110_B ; upstream PCM time slot 34, port 1
W:MAAR = 1111 1011_B ; address of upstream CFI time slot 123
W:MACR = 0111 0001_B ; write data + code field command, code "0001"

In a next step, the bandwidth of the previously made connection shall be verified:

W:MAAR = 1111 1011_B ; address of upstream CFI time slot 123
W:MACR = 1111 0000_B ; read back code field command
wait for STAR:MAC = 0
R:MADR = XXXX 0001_B ; the code "0001" (64 kbit/s channel) is read back

Tristate Behavior at the Configurable Interface

The downstream control memory code field, together with the CSCR and OMDR registers also defines the state of the output driver at the downstream CFI ports. Unassigned channels (code “0000”) are set to the inactive state. Subchannels (codes “0010” to “0111”) are only active during the subtime slot position specified in CSCR. The OMDR:COS bit selects between tristate outputs and open drain outputs:

Table 25

| Logical State | Tristate Outputs | Open Drain Outputs |
|---------------|--------------------|--------------------------|
| Logical 0 | Low voltage level | Low voltage level |
| Logical 1 | High voltage level | Not driven ¹⁾ |
| Inactive | High impedance | Not driven ¹⁾ |

1) An external pull-up resistor is required to establish a high voltage level.

Figure 55 illustrates this behavior in case of tristate outputs:

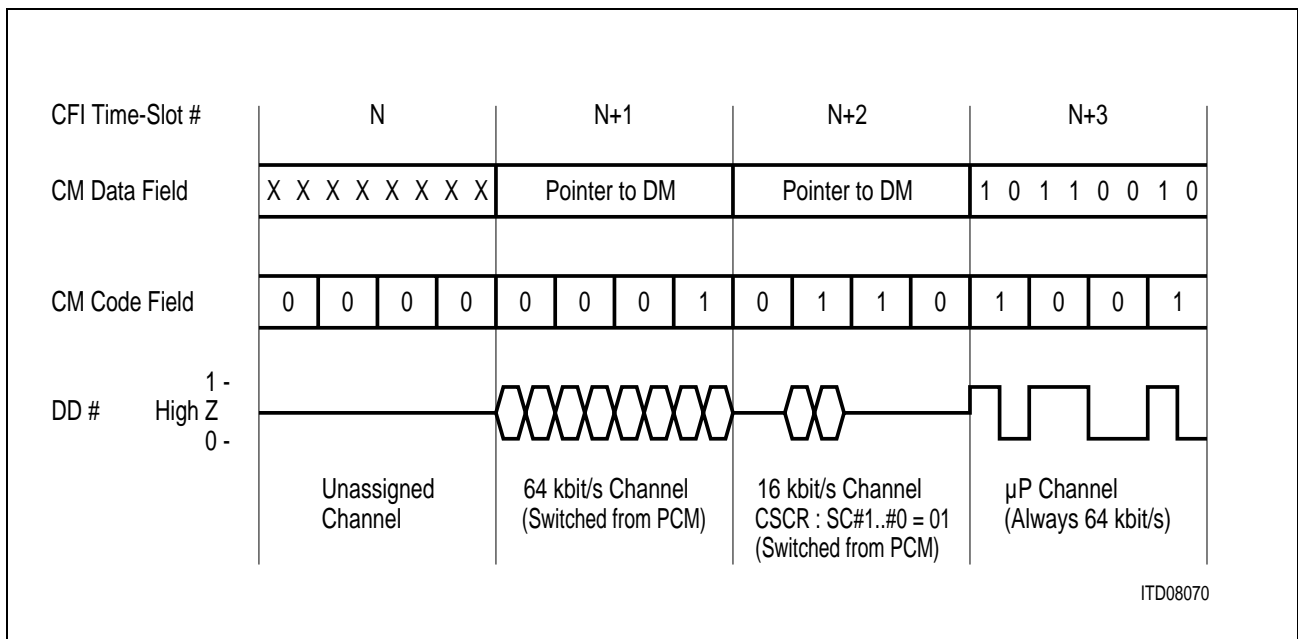

Figure 55
Tristate Behavior at the CFI

Table 26
Summary of Memory Operations

| Application | MADR | MAAR | MACR (Hex) |
|--|---|--|--|
| Writing a PCM idle value to the upstream DM data field The MACR value specifies the bandwidth and bit position at the PCM interface | 8 bit, 4 bit or 2 bit idle value to be transmitted at the PCM interface | Address of the (upstream) PCM port and time slot | 08 _H (bits 7 ... 0) 18 _H (bits 7 ... 4) 10 _H (bits 3 ... 0) 38 _H (bits 7 ... 6) 30 _H (bits 5 ... 4) 28 _H (bits 3 ... 2) 20 _H (bits 1 ... 0) |
| Reading the up- or downstream DM data field | 8 bit value transmitted at the upstream or 8 bit value received at the downstream PCM interface | Address of the PCM port and time slot | 88 _H |
| Writing to a single tristate field location | Tristate information contained in the 4 LSBs: 0 = tristated, 1 = active | Address of the (upstream) PCM port and time slot | 60 _H |
| Writing to all tristate field locations | Tristate information contained in the 4 LSBs: 0 = tristated, 1 = active | Don't care | 68 _H |
| Reading a single tristate field location | Tristate information contained in the 4 LSBs | Address of the (upstream) PCM port and time slot | E0 _H |
| Writing to the CM data field | 8 bit value (C/I value, pointer to PCM interface, etc.) | Address of the CFI port and time slot | 48 _H |

Table 26
Summary of Memory Operations

| Application | MADR | MAAR | MACR (Hex) |
|--|--|---------------------------------------|---|
| Reading the CM data field | 8 bit value (C/I value, pointer to PCM interface, etc.) | Address of the CFI port and time slot | C8 _H |
| Reading the CM code field | 4 bit code contained in the 4 LSBs | Address of the CFI port and time slot | F0 _H |
| Writing a switching code to the CM The MACR value specifies the bandwidth and bit position at the PCM interface | Pointer to DM: PCM port and time slot | Address of the CFI port and time slot | 70 _H (unassigned) 71 _H (bits 7 ... 0) 73 _H (bits 7 ... 4) 72 _H (bits 3 ... 0) 77 _H (bits 7 ... 6) 76 _H (bits 5 ... 4) 75 _H (bits 3 ... 2) 74 _H (bits 1 ... 0) |
| Writing the “μP channel” code to the CM | 8 bit idle value | Address of the CFI port and time slot | 79 _H |
| Writing a “preprocessed channel” code to the CM | refer to figure 68 | refer to figure 68 | refer to figure 68 |

5.4 Switched Channels

This chapter treats the switching functions between the CFI and PCM interfaces which are programmed exclusively in the control memory. The switching functions of channels which involve the μ P interface or which are programmed in the synchronous transfer registers are treated in **chapter 5.6** and **chapter 5.7**.

The EPIC is a non-blocking space and time switch for 128 channels per direction. Switching is performed between the configurable (CFI) and the PCM interfaces. Both interfaces provide up to 128 time slots which can be split up into either 4 ports with up to 32 time slots, 2 ports with up to 64 time slots or 1 port with up to 128 time slots. In all of these cases each port consists of a separate transmit and receive line (duplex ports). On the CFI side a bidirectional mode is also provided (CFI mode 3) which offers 8 ports with up to 16 time slots per port. In this case each time slot of each port can individually be programmed to be either input or output.

The time slot numbering always ranges from 0 to $N - 1$ (N = number of time slots/frame), and each time slot always consists of 8 contiguous bits. The bandwidth of a time slot is therefore always 64 kbit/s.

The EPIC can switch single time slots (64 kbit/s channels), double time slots (128 kbit/s channels) and also 2 bit and 4 bit wide subtime slots (16 and 32 kbit/s channels). The bits in a time slot are numbered 7 through 0. On the serial interfaces (PCM and CFI), bit 7 is the first bit to be transmitted or received, bit 0 the last. If the μ P has access to the serial data, bit 7 represents the MSB (D7) and bit 0 the LSB (D0) on the μ P bus.

The switching of 128 kbit/s channels implies that two consecutive time slots starting with an even time slot number are used, e.g. PCM time slots 22 and 23 can be switched as a single 16 bit wide time slot to CFI time slots 4 and 5. Under these conditions it is guaranteed that the involved time slots are submitted to the same frame delay (also refer to **chapter 5.4.4**).

The switching of channels with a data rate of 16 and 32 kbit/s is possible for the following subtime slot positions within an 8 bit time slot:

Application Hints

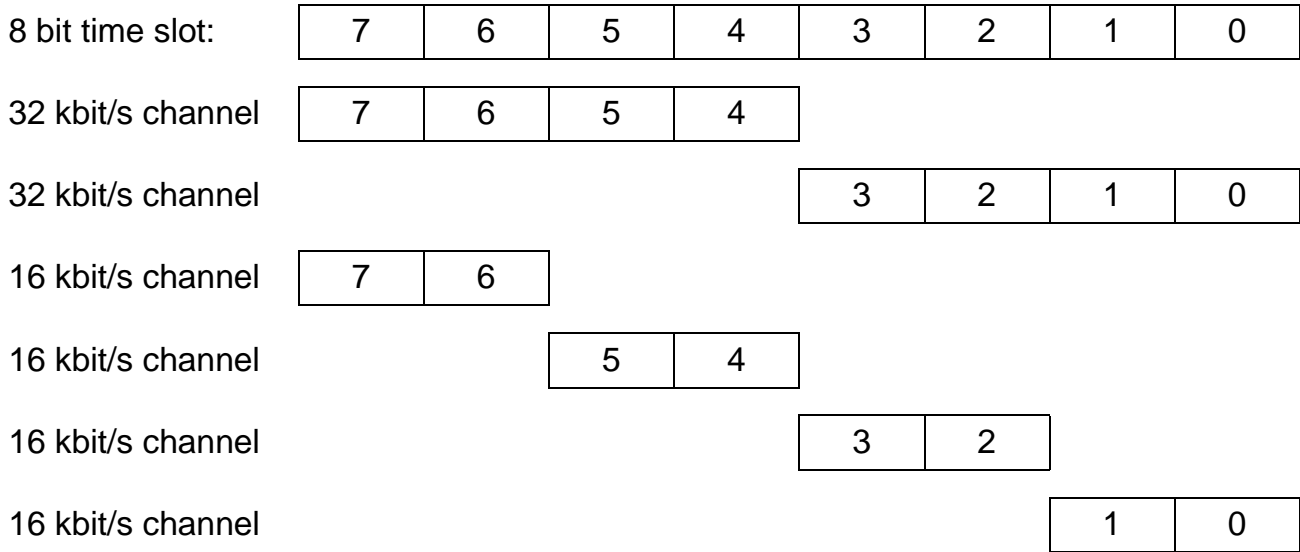

5.4.1 CFI - PCM Time Slot Assignment

All time slot assignments are programmed in the control memory (CM). Each line (address) of the CM refers to one CFI time slot. The MAAR register, which is used to address the CM, therefore specifies the CFI port and time slot to be switched. The data field of the CM contains a pointer which points to a location in the data memory (DM). The data memory contains the actual PCM data to be switched. The MADR register contains the data to be copied to the CM data field. Since this data is interpreted as a pointer to the DM, the MADR contents therefore specifies the PCM port and time slot to be switched. The 4 bit CM code field must finally contain a value to declare the corresponding CFI time slot as a switched channel (codes with a leading 0). This code must be written at least once to the CM using the MACR register.

Since the CFI - PCM time slot assignment is programmed at the CFI side, it is possible to switch a single downstream PCM time slot to several downstream CFI time slots. It is, however, not possible to switch a single upstream CFI time slot to several upstream PCM time slots.

If several upstream 64 kbit/s CFI time slots are assigned to the same upstream 64 kbit/s PCM time slot, only the data of one CFI time slot will actually be switched since each upstream connection will simply overwrite the DM data field. This switching mode can therefore only effectively be used if the upstream switching is performed on different subtime slot locations within the same PCM time slot (refer to **chapter 5.4.2**).

The following sequences can be used to program, verify, and cancel a CFI - PCM time slot connection:

Programming of a 64 kbit/s CFI - PCM Time Slot Connection

- in case the CM code field has not yet been initialized with a switching code:

W:MADR = PCM port and time slot encoded according to **figure 48**
 W:MAAR = CFI port and time slot encoded according to **figure 48**
 W:MACR = 0111 0001_B = 71_H

- in case the CM code field has already been initialized with a switching code:

W:MADR = PCM port and time slot encoded according to **figure 48**
 W:MAAR = CFI port and time slot encoded according to **figure 48**
 W:MACR = 0100 1000_B = 48_H

Enabling the PCM Output Driver for a 64 kbit/s Time Slot

W:MADR = XXXX 1111_B = XF_H
 W:MAAR = PCM port and time slot encoded according to **figure 48**
 W:MACR = 0110 0000_B = 60_H

Reading Back a Time Slot Assignment of a Given CFI Time Slot

- reading back the PCM time slot involved:

W:MAAR = CFI port and time slot encoded according to **figure 48**
 W:MACR = 1100 1000_B = C8_H
 wait for STAR:MAC = 0
 R:MADR = PCM port and time slot encoded according to **figure 48**

- reading back the involved bandwidth and PCM subtime slot position:

W:MAAR = CFI port and time slot encoded according to **figure 48**
 W:MACR = 1111 0000_B = F0_H
 wait for STAR:MAC = 0
 R:MADR = XXXX code; 4 bit bandwidth code encoded according to **table 24**

Cancelling of a Programmed CFI - PCM Time Slot Connection

W:MADR = don't care
 W:MAAR = CFI port and time slot encoded according to **figure 48**
 W:MACR = 0111 0000_B = 70_H; code "0000" (unassigned channel)

Disabling the PCM Output Driver

W:MADR = XXXX 0000_B = X0_H
 W:MAAR = PCM port and time slot encoded according to **figure 48**
 W:MACR = 0110 0000_B = 60_H

Examples

In PCM mode 1 and CFI mode 3 the following connections shall be programmed:

Upstream: CFI port 5, time slot 7, bits 7 ... 0 to PCM port 0, time slot 12, bits 7 ... 0

W:MADR = 1001 1000_B ; PCM time slot encoding according to **figure 48**

W:MAAR = 1011 1011_B ; CFI time slot encoding according to **figure 48**

W:MACR = 0111 0001_B ; CM code for switching a 64 kbit/s channel
(code "0001")

Downstream: CFI port 4, time slot 2, bits 7 ... 0 from PCM port 1, time slot 3, bits 7 ... 0

W:MADR = 0000 0111_B ; PCM time slot encoding according to **figure 48**

W:MAAR = 0001 1000_B ; CFI time slot encoding according to **figure 48**

W:MACR = 0111 0001_B ; CM code for switching a 64 kbit/s channel (0001)

The following sequence sets transmit time slot 12 of PCM port 0 to low impedance:

W:MADR = 0000 1111_B ; all bits to low Z

W:MAAR = 1001 1011_B ; PCM time slot encoding according to **figure 48**

W:MACR = 0110 0000_B ; MOC code "1100" to access the tristate field

After these three programming steps, the EPIC memories will have the following contents:

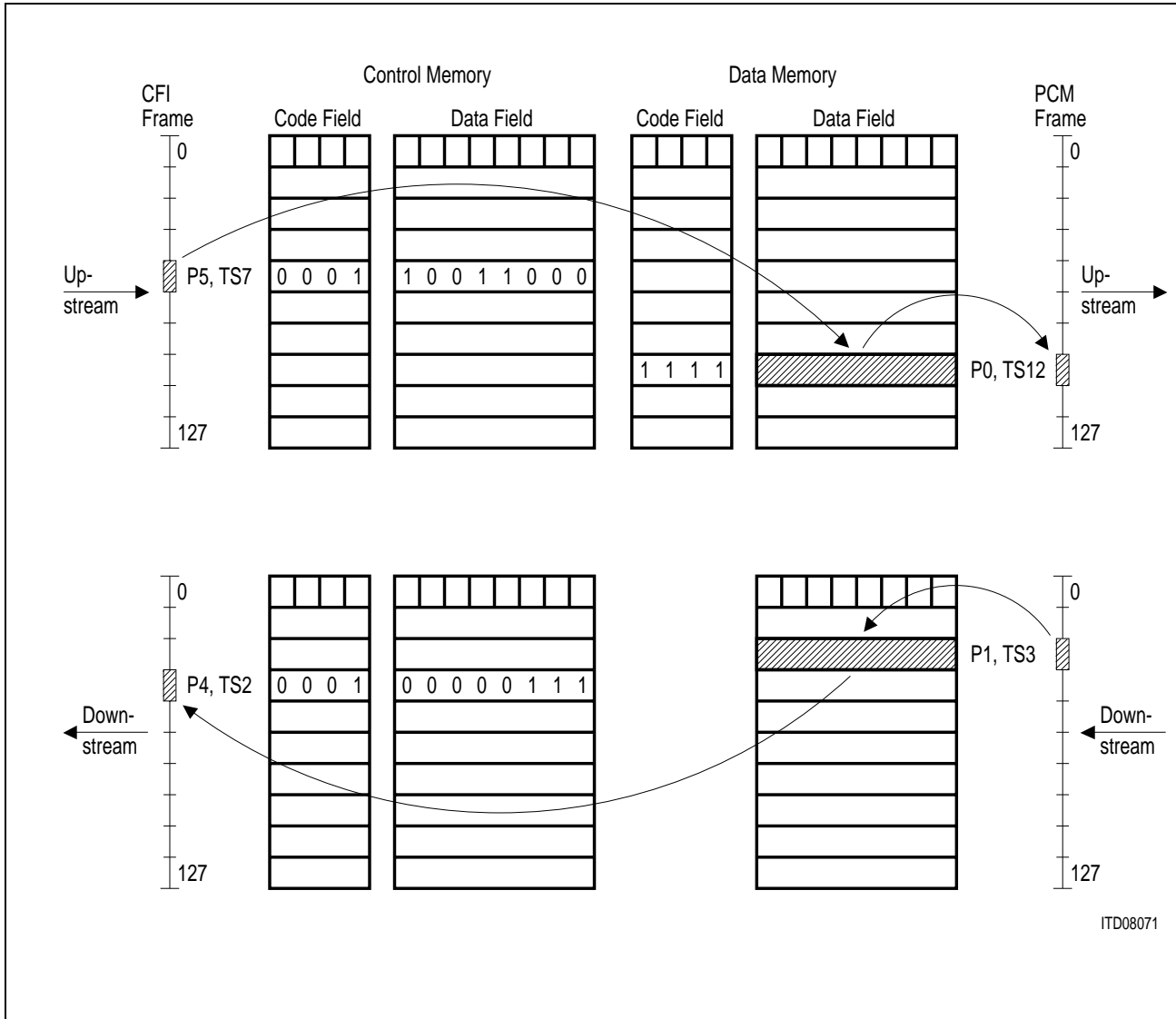

Figure 56
Memory Content of the EPIC® for a CFI - PCM Time Slot Connection

Subchannel selection SC#1 ... SC#0 = 00:

| CM code | CFI subchannel position | switched to or from | PCM subchannel position |
|---------|-------------------------|---------------------|-------------------------|
| | ← CFI time slot → | | ← PCM time slot → |
| 0001 | 7 6 5 4 3 2 1 0 | ↔ | 7 6 5 4 3 2 1 0 |
| 0011 | 7 6 5 4 | ↔ | 7 6 5 4 |
| 0010 | 7 6 5 4 | ↔ | 3 2 1 0 |
| 0111 | 7 6 | ↔ | 7 6 |
| 0110 | 7 6 | ↔ | 5 4 |
| 0101 | 7 6 | ↔ | 3 2 |
| 0100 | 7 6 | ↔ | 1 0 |

Subchannel selection SC#1 ... SC#0 = 01:

| CM code | CFI subchannel position | switched to or from | PCM subchannel position |
|---------|-------------------------|---------------------|-------------------------|
| | ← CFI time slot → | | ← PCM time slot → |
| 0001 | 7 6 5 4 3 2 1 0 | ↔ | 7 6 5 4 3 2 1 0 |
| 0011 | 3 2 1 0 | ↔ | 7 6 5 4 |
| 0010 | 3 2 1 0 | ↔ | 3 2 1 0 |
| 0111 | 5 4 | ↔ | 7 6 |
| 0110 | 5 4 | ↔ | 5 4 |
| 0101 | 5 4 | ↔ | 3 2 |
| 0100 | 5 4 | ↔ | 1 0 |

Subchannel selection SC#1 ... SC#0 = 10:

| CM code | CFI subchannel position | switched to or from | PCM subchannel position |
|---------|-------------------------|---------------------|-------------------------|
| | ← CFI time slot → | | ← PCM time slot → |
| 0001 | 7 6 5 4 3 2 1 0 | ↔ | 7 6 5 4 3 2 1 0 |
| 0011 | 7 6 5 4 | ↔ | 7 6 5 4 |
| 0010 | 7 6 5 4 | ↔ | 3 2 1 0 |
| 0111 | 3 2 | ↔ | 7 6 |
| 0110 | 3 2 | ↔ | 5 4 |
| 0101 | 3 2 | ↔ | 3 2 |
| 0100 | 3 2 | ↔ | 1 0 |

Subchannel selection SC#1 ... SC#0 = 11:

| CM code | CFI subchannel position | switched to or from | PCM subchannel position |
|---------|-------------------------|---------------------|-------------------------|
| | ← CFI time slot → | | ← PCM time slot → |
| 0001 | 7 6 5 4 3 2 1 0 | ↔ | 7 6 5 4 3 2 1 0 |
| 0011 | 3 2 1 0 | ↔ | 7 6 5 4 |
| 0010 | 3 2 1 0 | ↔ | 3 2 1 0 |
| 0111 | 1 0 | ↔ | 7 6 |
| 0110 | 1 0 | ↔ | 5 4 |
| 0101 | 1 0 | ↔ | 3 2 |
| 0100 | 1 0 | ↔ | 1 0 |

Examples

In PCM mode 0 and CFI mode 0 the following connections shall be programmed:

Upstream: CFI port 0, time slot 3, bits 1 ... 0 to PCM port 0, time slot 4, bits 1 ... 0

W:MADR = 1001 0000_B PCM time slot encoding, the subchannel position is defined by MACR:CMC3 ... 0 = 0100

W:MAAR = 1000 1001_B CFI time slot encoding, the subchannel position is defined by CSCR:SC01 ... 00 = 11

W:MACR = 0111 0100_B CM code for switching a 16 kbit/s/bits 1 ... 0 channel (0100)

Upstream: CFI port 3, time slot 7, bits 3 ... 2 to PCM port 0, time slot 4, bits 5 ... 4

W:MADR = 1001 0000_B PCM time slot encoding, the subchannel position is defined by MACR:CMC3 ... 0 = 0110

W:MAAR = 1001 1111_B CFI time slot encoding, the subchannel position is defined by CSCR:SC31 ... 30 = 10

W:MACR = 0111 0110_B CM code for switching a 16 kbit/s, bits 3 ... 2 channel (0110)

The following sequence sets transmit time slot 4 of PCM port 0 bits 5 ... 4 and 1 ... 0 to low impedance and bits 7 ... 6 and 3 ... 2 to high impedance:

W:MADR = 0000 0101_B bits 5, 4, 1, 0 to low Z and bits 7, 6, 3, 2 to high Z

W:MAAR = 1001 0000_B PCM time slot encoding

W:MACR = 0110 0000_B MOC code to access the tristate field

Downstream: CFI port 2, time slot 7, bits 3 ... 0 from PCM port 1, time slot 3, bits 7 ... 4

W:MADR = 0000 1011_B PCM time slot encoding, the subchannel position is defined by MACR:CMC3 ... 0 = 0011

W:MAAR = 0001 1101_B CFI time slot encoding, the subchannel position is defined by CSCR:SC21 ... 20 = 01

W:MACR = 0111 0011_B CM code for switching a 32 kbit/s/bits 7 ... 4 channel (0011)

Application Hints

Downstream: CFI port 2, time slot 10, bits 5 ... 4 from PCM port 0, time slot 4, bits 7 ... 6

W:MADR = 0001 0000_B PCM time slot encoding, the subchannel position is defined by MACR:CMC3 ... 0 = 0111

W:MAAR = 0010 1100_B CFI time slot encoding, the subchannel position is defined by CSCR:SC21 ... 20 = 01

W:MACR = 0111 0111_B CM code for switching a 16 kbit/s/bits 7 ... 6 channel (0111)

Finally the CSCR register has to be programmed to define the subchannel positions at the CFI:

W:CSCR = 1001 XX11_B port 0: bits 1 ... 0 or 3 ... 0; port 1: not used in this example;

port 2: bits 5 ... 4 or 3 ... 0; port 3: bits 3 ... 2 or 7 ... 4

After these three programming steps, the EPIC memories will have the following content:

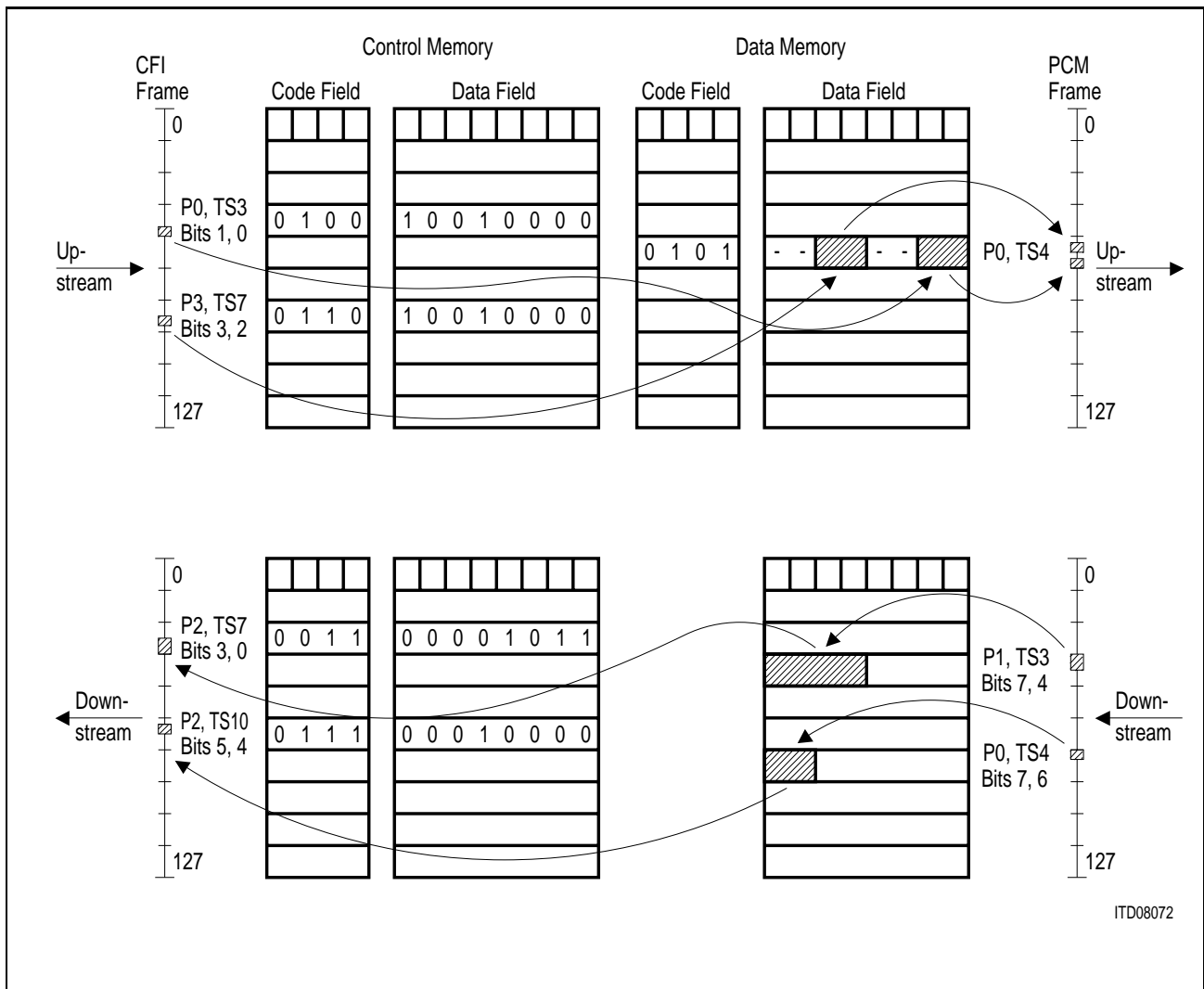

ITD08072

Figure 57
Memory Content in Case of CFI - PCM Subchannel Connections

5.4.3 Loops

Loops between time slots (or even subtime slots) of the CFI (CFI → CFI) or the PCM interface (PCM → PCM) can easily be programmed in the control memory. It is thus possible to establish individual loops for individual time slots on both interfaces without making external connections. These loops can serve for test purposes only or for real switching applications within the system. It should be noted that such a loop connection is always carried out over the opposite interface i.e. looping back a CFI time slot to another CFI time slot occupies a spare upstream PCM time slot and looping back a PCM time slot to another PCM time slot occupies a spare downstream and upstream CFI time slot. The required time slot on the opposite interface can however be switched to high impedance in order not to disturb the external line.

5.4.3.1 CFI - CFI Loops

For looping back a time slot of a CFI input port to a CFI output port, two connections must be programmed:

A first connection switches the upstream CFI time slot to a spare PCM time slot. This connection is programmed like a normal CFI to PCM link, i.e. the MADR contains the encoding for the upstream PCM time slot ($U/\overline{D} = 1$) which is written to the upstream CM (MAAR contains the encoding for the upstream CFI time slot ($U/\overline{D} = 1$)). If the data should also be transmitted at $TxD\#$, the tristate field of that PCM time slot can be set to low impedance (transparent loop). If $TxD\#$ should be disabled, the tristate field of that PCM time slot can be set to high impedance (non-transparent loop).

The second connection switches the “upstream” PCM time slot (contents of the upstream data memory) back to the downstream CFI time slot. This connection is programmed by using exactly the same MADR value as has been used for the first connection, i.e. the encoding for the spare upstream PCM time slot (with $U/\overline{D} = 1$). This MADR value is written to the downstream CM (MAAR contains the encoding for the downstream CFI time slot ($U/\overline{D} = 0$)).

The following example illustrates the necessary programming steps for establishing CFI to CFI loops.

Example

In PCM mode 0 and CFI mode 0 the following non-transparent CFI to CFI loop via PCM port 0, time slot 0 shall be programmed:

Upstream: CFI port 2, time slot 4, bits 7 ... 0 to PCM port 0, time slot 0, bits 7 ... 0

W:MADR = 1000 0000_B PCM time slot encoding (pointer to upstream DM)
 W:MAAR = 1001 0100_B CFI time slot encoding (address of upstream CM)
 W:MACR = 0111 0001_B CM code for switching a 64 kbit/s/bits 7 ... 0 channel (0001)

Downstream: CFI port 1, time slot 7, bits 7 ... 0 from PCM port 0, time slot 0, bits 7 ... 0

W:MADR = 1000 0000_B PCM time slot encoding (pointer to **upstream** DM)
 W:MAAR = 0001 1011_B CFI time slot encoding (address of downstream CM)
 W:MACR = 0111 0001_B CM code for switching a 64 kbit/s/bits 7 ... 0 channel (0001)

The following sequence sets transmit time slot 0 of PCM port 0 to high impedance:

W:MADR = 0000 0000_B all bits to high Z
 W:MAAR = 1000 0000_B PCM time slot encoding
 W:MACR = 0110 0000_B MOC code to access the tristate field

After these three programming steps, the EPIC memories will have the following contents:

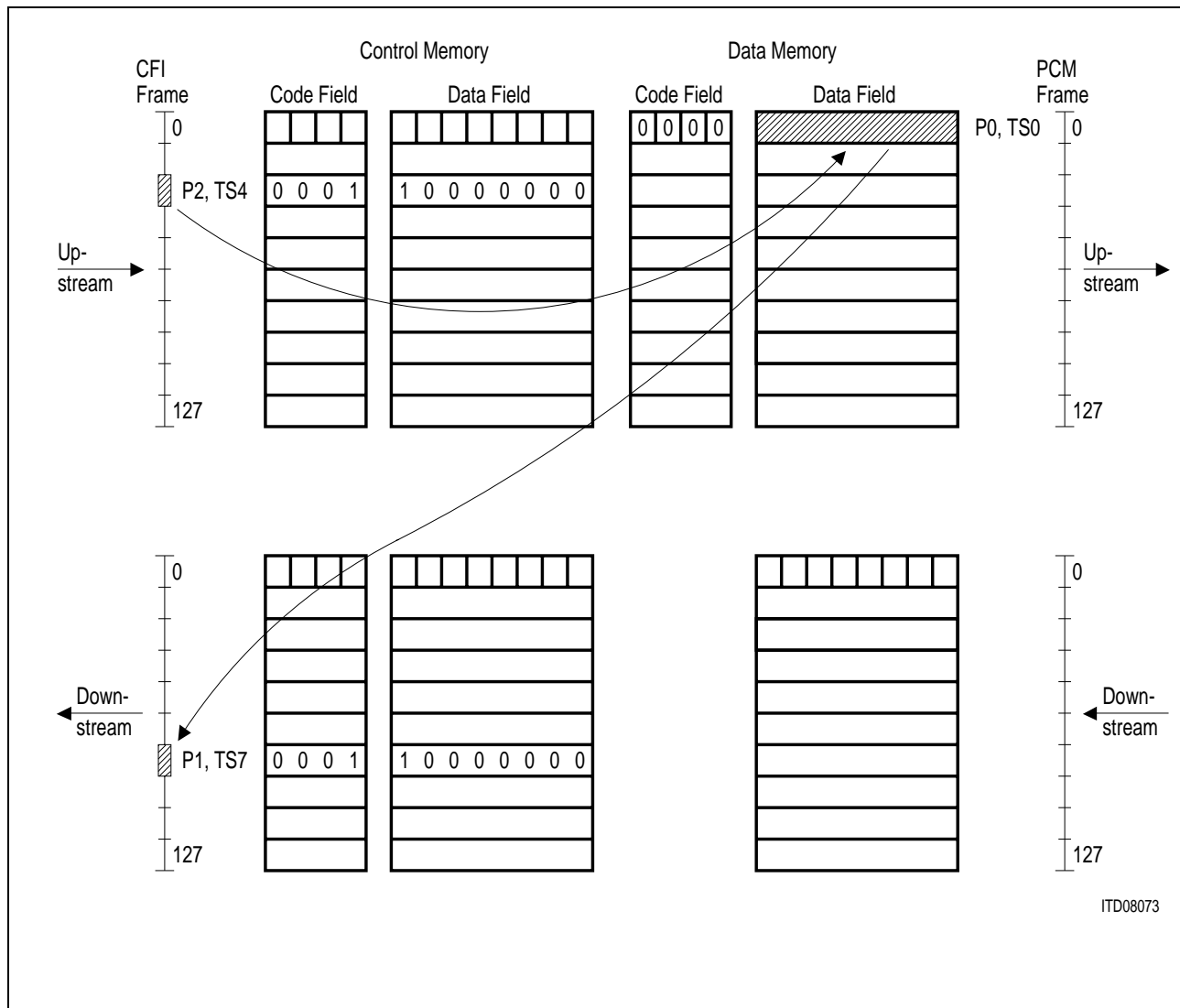

ITD08073

Figure 58
Memory Content in Case of a CFI → CFI Loop

5.4.3.2 PCM - PCM Loops

For looping back a time slot of a PCM input port to a PCM output port, two connections must be programmed:

The first connection switches the downstream PCM time slot to a spare CFI time slot. This connection is programmed like a normal PCM to CFI link, i.e. the MADR contains the encoding for the downstream PCM time slot ($U/\overline{D} = 0$) which is written to the downstream CM (MAAR contains the encoding for the downstream CFI time slot ($U/\overline{D} = 0$)). If the data should also be transmitted at DD# (transparent loop), the programming is performed with MACR:CMC3 ... 0 = 0001 ... 0111, the actual code depending on the required bandwidth. If DD# should be disabled (non-transparent loop), the programming is performed with MACR:CMC3 ... 0 = 0000, the code for unassigned channels.

The second connection switches the serial CFI time slot data back to the upstream PCM time slot. This connection is programmed by writing the encoded PCM time slot via MADR to the upstream CM. This "upstream" pointer must however have the MSB set to 0 ($U/\overline{D} = 0$). This MADR value is written to the same spare CFI time slot as the PCM time slot had been switched to in the first step. Only that now the upstream CM is accessed (MAAR addresses the upstream CFI time slot ($U/\overline{D} = 1$)).

In contrast to the CFI → PCM → CFI loop, which is internally realized by extracting the CFI data out of the upstream data memory (see **chapter 5.4.3.1**), the PCM → CFI → PCM loop is realized differently:

The downstream PCM → CFI connection switches the PCM data to the internal downstream serial CFI output. From this internal output, the data is switched to the upstream serial CFI input if the control memory of the corresponding upstream CFI time slot contains a pointer with a leading 0 ($U/\overline{D} = 0$). However, this pointer (with $U/\overline{D} = 0$) still points to the upstream data memory, i.e. to an upstream PCM time slot.

The following example illustrates the necessary programming steps for establishing PCM to PCM loops:

Example

In PCM mode 1 and CFI mode 0 the following non-transparent PCM to PCM loop via CFI port 1, time slot 4 shall be programmed:

Downstream: CFI port 1, time slot 4, bits 7 ... 0 from PCM port 0, time slot 13, bits 7 ... 0

| | | | |
|--------|---|------------------------|---|
| W:MADR | = | 0001 1001 _B | PCM time slot encoding (pointer to downstream DM) |
| W:MAAR | = | 0001 0010 _B | CFI time slot encoding (address of downstream CM) |
| W:MACR | = | 0111 0000 _B | CM code for unassigned channel (0000) |

Application Hints

Upstream: CFI port 1, time slot 4, bits 7 ... 0 to PCM port 0, time slot 5, bits 7 ... 0

W:MADR = 0000 1001_B PCM time slot encoding (pointer to "upstream" DM, loop switch (MSB = 0) activated)

W:MAAR = 1001 0010_B CFI time slot encoding (address of upstream CM)

W:MACR = 0111 0001_B CM code for switching a 64 kbit/s, bits 7 ... 0 channel (0001)

The following sequence sets transmit time slot 5 of PCM port 0 to low impedance:

W:MADR = 0000 1111_B all bits to low Z

W:MAAR = 1000 1001_B PCM time slot encoding

W:MACR = 0110 0000_B MOC code to access the tristate field

After these three programming steps, the EPIC memories will have the following contents:

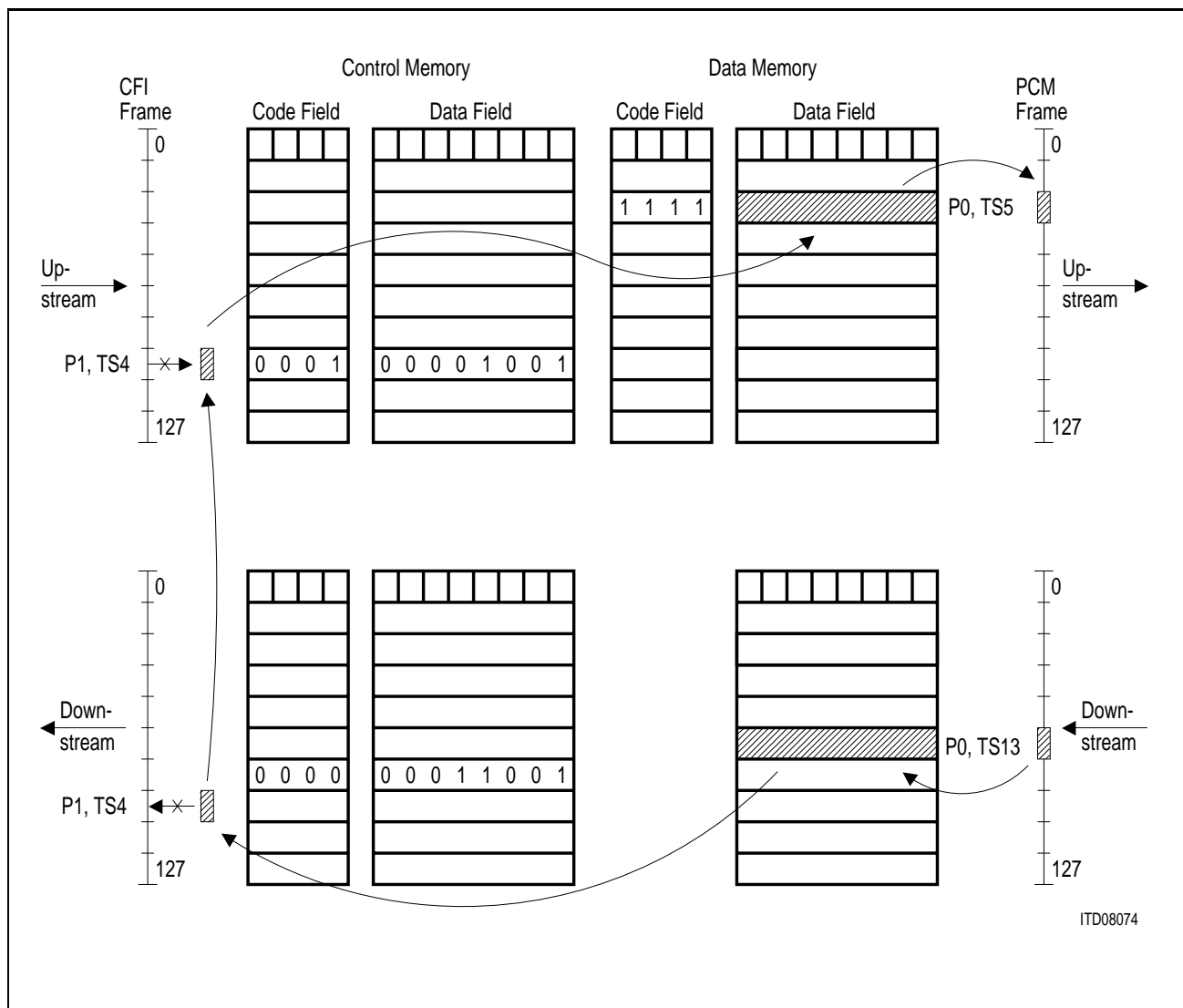

Figure 59
Memory Content in Case of a PCM → PCM Loop

5.4.4 Switching Delays

When a channel is switched from an input time slot (e.g. from the PCM interface) to an output time slot (e.g. to the CFI), it is sometimes useful to know the frame delay introduced by this connection. This is of prime importance for example if channels having a bandwidth of $n \times 64$ kbit/s (e.g. H0 channels: $6 \times 64 = 384$ kbit/s) shall be switched by the EPIC. If all 6 time slots of an H0 channel are not submitted to the same frame delay, time slot integrity is no longer maintained.

Since the EPIC has only a one frame buffer, the switching delay depends mainly on the location of the output time slot with respect to the input time slot. If there is "enough" time between the two locations, the EPIC switches the input data to the output data within the same frame (see **figure 60 a**). If the time between the two locations is too small or if the output time slot is later in time than the input time slot, the data received in frame N will only be transmitted in frame N + 1 or even N + 2 (see **figure 60 b**) and **figure 60 c**).

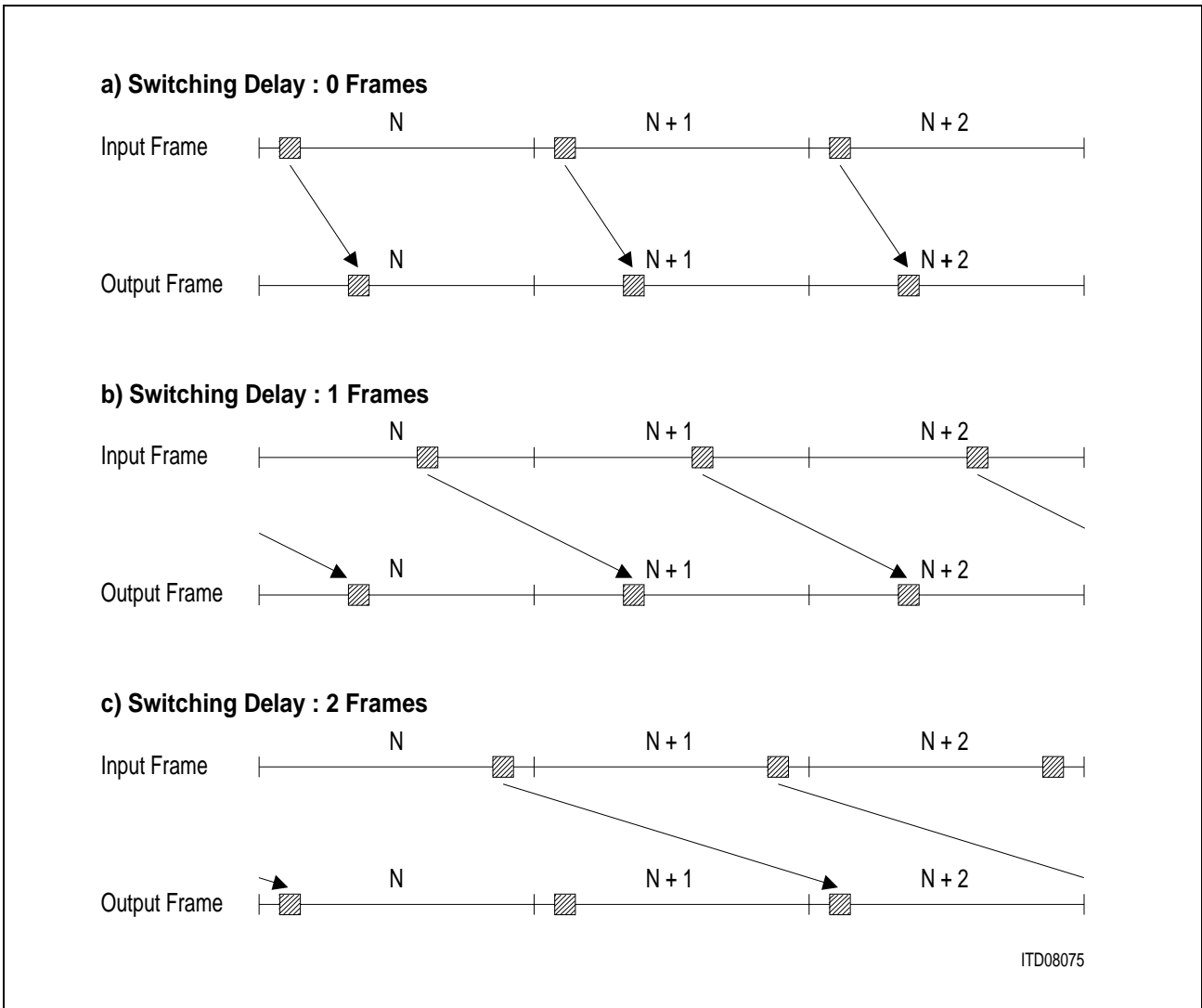

Figure 60
Switching Delays

The exact respective time slot positions where the delay skips from 0 frames to 1 frame and from 1 frame to 2 frames can be determined when having a closer look at the internal read and write cycles to the Data Memory.

The next two figures show the internal timing characteristics for the access to the data memory (DM) of the EPIC. For simplicity, only the case where the PCM and CFI frames both start simultaneously at position “time slot 0, bit 7” is shown. Also, only the cases with 2, 4 and 8 × 1024 kbit/s data rates are shown. All other cases (different frame offsets and different data rates) can, however, be deduced by taking into account the respective frame positions, and, eventually, by taking into account a different RCL frequency.

5.4.4.1 Internal Procedures at the Serial Interfaces

The data is received and transmitted at the PCM and configurable interfaces in a serial format. Before being written to the DM, the data is converted into parallel format. The vertical arrows indicate the position in time where the incoming time slot data is written to the data memory. The writing to the DM is only possible during certain time intervals which are also indicated in the figures. For outgoing time slots, the data is first read in parallel format from the DM. This also is only possible during certain read cycles as indicated in the figures (vertical arrows). Before the time slot data is sent out, it must first be converted into serial format.

The data contained in a time slot can be switched from an incoming time slot position to an outgoing time slot position within the same frame (0 frame delay) if the reading from the DM occurs after the writing to the DM. If the reading occurs before the writing, the data from the previous frame is taken, i.e. the frame delay is one frame.

No Bit Shift at PCM and CFI Interface

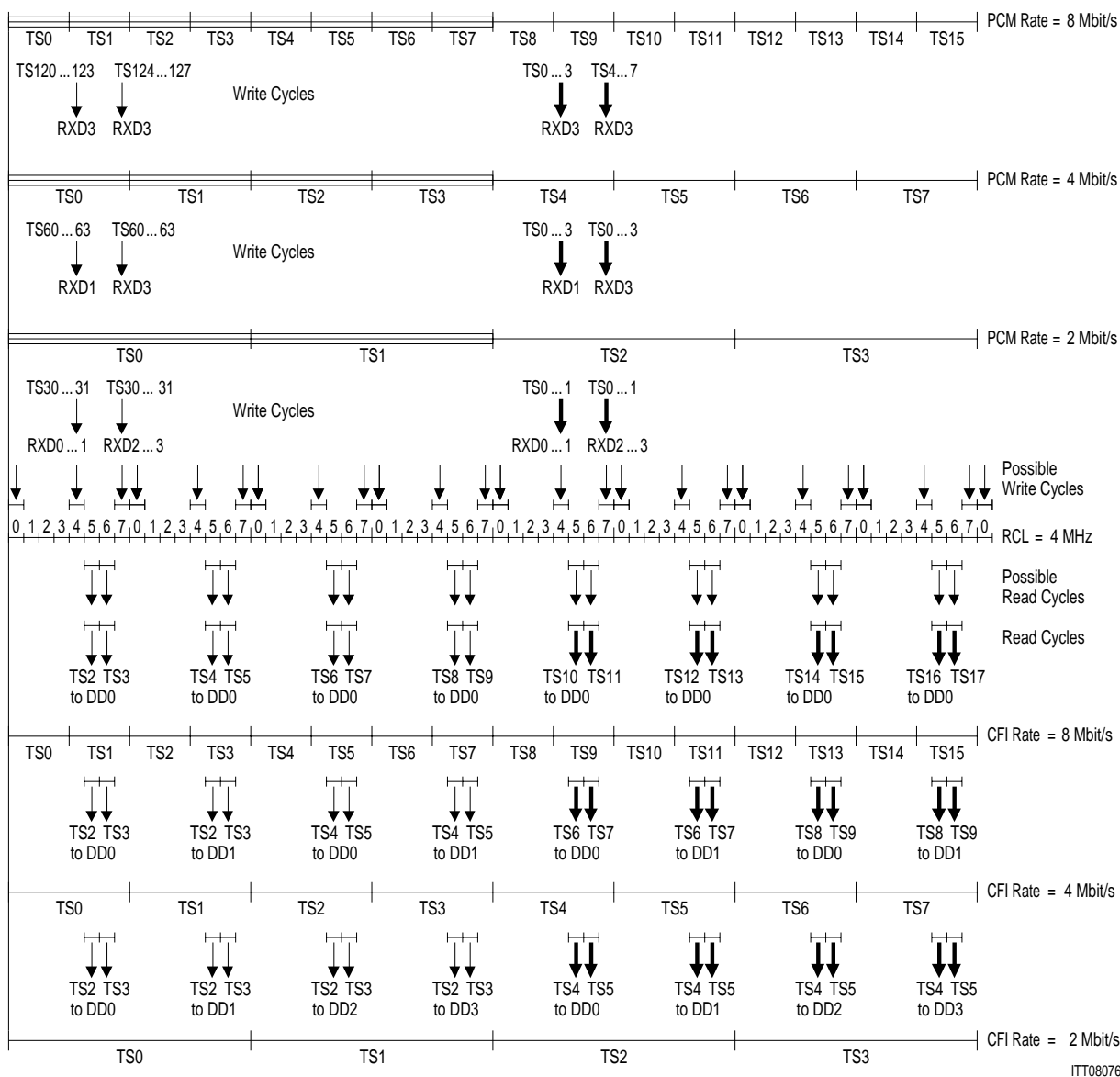

Figure 61
Internal Timing Data Downstream

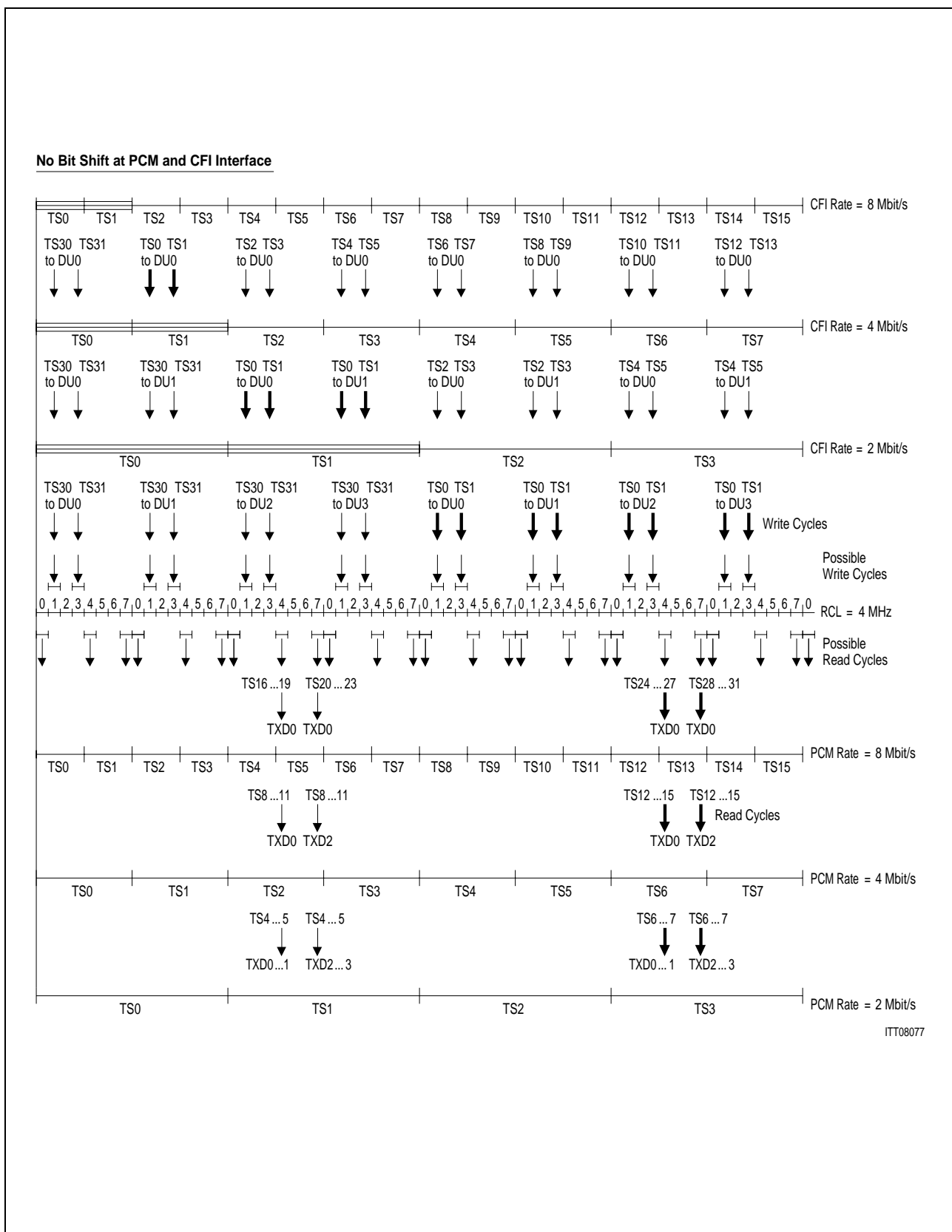

Figure 62
Internal Timing Data Upstream

5.4.4.2 How to Determine the Delay

In order to determine the switching delay for a certain configuration, the following rules have to be applied with respect to the timing diagram:

Data Downstream

- At the PCM interface the incoming data (data downstream) is written to the RAM after the beginning of:

time slot: $2 \times n$ for mode 0

time slot: $4 \times n$ for mode 1

time slot: $8 \times n$ for mode 2

Note: n is an integer number.

The point of time to write the data to the RAM is RCL period 0, 4, 7 for the PCM interface. Due to internal delays, the RCL period at the beginning of time slot $2 \times n$ (for mode 0), $4 \times n$ (for mode 1), $8 \times n$ for mode 2) is not a valid write cycle.

- At the CFI interface the data, that is to be transmitted on:

TS $2 \times n + 4 \dots 2 \times n + 5$ (CFI mode 0)

TS $2 \times n + 6 \dots 2 \times n + 7$ (CFI mode 1)

TS $2 \times n + 10 \dots 2 \times n + 11$ (CFI mode 2)

is read out of the RAM as soon as time slot:

$2 \times n + 1$ (for mode 0)

$2 \times n + 3$ (for mode 1)

$2 \times n + 7$ (for mode 2) **is transmitted**

Note: n is an integer number; the time slot number can't exceed the max. number of TS.

The point of time to read the data from the RAM is RCL period 5 and 6 for the CFI interface.

The data is read out of the RAM in several steps in the following order:

CFI mode 0: - even TS for DD0, odd TS for DD0,
even TS for DD1, odd TS for DD1,
even TS for DD2, odd TS for DD2,
even TS for DD3, odd TS for DD3

CFI mode 1: - even TS for DD0, odd TS for DD0,
even TS for DD1, odd TS for DD1

CFI mode 2: - even TS for DD0, odd TS for DD0

Data Upstream

- At the CFI interface the incoming data (data upstream) is written to the RAM starting with DU0 at the beginning of:

time slot: $2 \times n$ for CFI mode 0

time slot: $2 \times n$ for CFI mode 1

time slot: $2 \times n$ for CFI mode 2

Note: n is an integer number; the time slot number can't exceed the max. number of TS.

The point of time to write the data to the RAM is RCL period 1 and 3 for the CFI interface

- At the PCM interface the data, that is to be transmitted on

TS $2 \times n + 4$... TS $2 \times n + 5$ (for PCM mode 0)

TS $4 \times n + 8$... TS $4 \times n + 11$ (for PCM mode 1)

TS $8 \times n + 16$... TS $8 \times n + 23$ (for PCM mode 2)

is read out of the RAM as soon as time slot:

$2 \times n$ (for PCM mode 0)

$4 \times n + 1$ (for PCM mode 1)

$8 \times n + 3$ (for PCM mode 2) is transmitted

Note: n is an integer number; the time slot number can't exceed the max. number of TS.

The point of time to read the data from the RAM, is RCL period 0, 4, 7 for the PCM interface

Due to internal delays, the RCL period at the beginning of time slot $2 \times n + 1$ (for PCM 0), $4 \times n + 2$ (for PCM mode1), $8 \times n + 4$ for PCM mode 2) is no valid write cycle.

The data is read out of the RAM in two steps:

PCM mode 0: in a block of 2 TS for TXD0 ... 1 then for TXD2 ... 3

PCM mode 1: in a block of 4 TS for TXD0 then for TXD2

PCM mode 2: in halves of a 8 TS blocks for TXD0 (first half) then for TXD0 (second half)

Considering a Bit Shift

A bit shift will also influence switching delays.

If the PCM frame is shifted relative to the frame signal, proceed as indicated below:

Shift only the PCM part of the figure ('PCM line' with the time slot numbers), relative to the rest of the figure, to the left.

If the CFI frame is shifted relative to the framing signal, then the CFI part, including the figure of the RCL, and all read and write cycle points are shifted left relative to the PCM part. If CBSR:CDS = 000 or 001, then the frame CFI part is shifted to the right.

The figure so produced should be processed as previously described.

Note: If a bit shift has been installed while the PCM interface is already in the synchronous state, the following procedure has to be applied:

- 1.) Unsynchronize the PCM interface by writing an invalid number to register PBNR*
- 2.) Resynchronize the PCM interface by writing the correct number to PBNR*

5.4.4.3 Example: Switching of Wide Band ISDN Channels with the EPIC®

The EPIC shall switch 6 B-channels of a digital subscriber to an 8 MBit/s PCM highway guaranteeing frame integrity. The system uses the IOM-2 interface to adapt to a multiple S-interface. No bit shift has to be applied. The tables below will help to determine the combination of input/output ports and time slots, that meet the requirements.

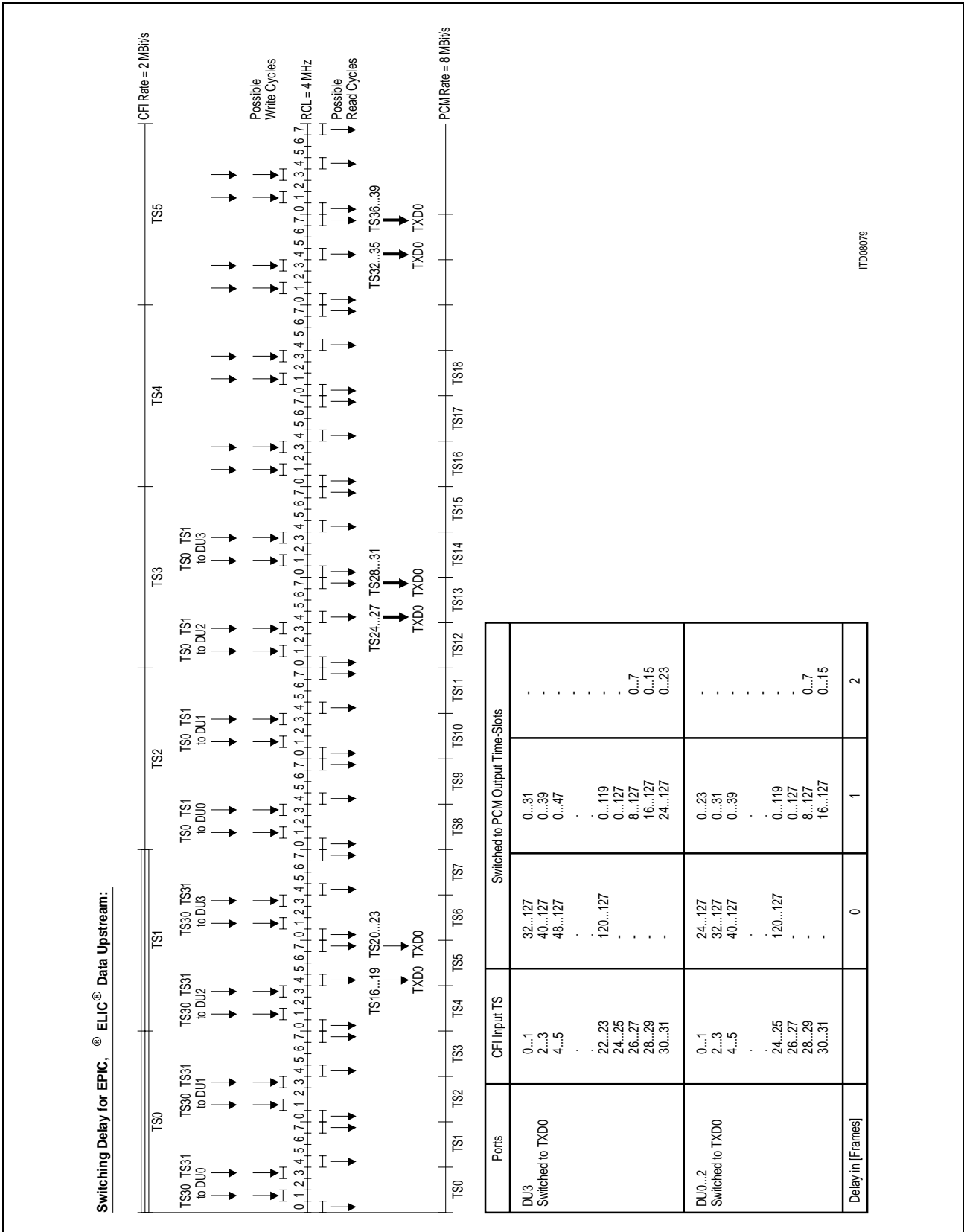

Figure 64
Calculation of Upstream Switching Delay

5.5 Preprocessed Channels

The configurable interface (CFI) is at first sight a time slot oriented serial interface similar to the PCM interface: a CFI frame contains a number of time slots which can be switched to the PCM interface. But in addition to the switching functions, the CFI time slots can also individually be configured as preprocessed channels. In this case, the contents of a CFI time slot are directly, or after an eventual preprocessing, exchanged with the μ P interface. The main application is the realization of IOM (ISDN Oriented Modular) and SLD (Subscriber Line Data) interfaces for the connection of subscriber circuits such as layer-1 transceivers (ISDN line cards) or codec filter devices (analog line cards). Also refer to **chapter 5.1.1**.

The preprocessing functions can be divided into 2 categories:

Monitor/Feature Control (MF) Channels

The monitor channel in IOM and the feature control channel in SLD applications are handled by the MF handler. This MF handler consists of a 16 byte bidirectional FIFO providing intermediate storage for the messages to be transmitted or received. Internal microprograms can be executed in order to control the communication with the connected subscriber circuit according to the IOM or SLD protocol. The exchange of individual data is carried out with only one channel at a time. The MF handler must therefore be pointed to that particular subscriber address (CFI time slot).

Control/Signaling (CS) Channels

The access to the Command/Indication (C/I) channel of an IOM and to the signaling (SIG) channel of an SLD interface is realized by reading or writing to the corresponding control memory (CM) locations. In upstream direction, a change detection logic supervises the received C/I or SIG values on all CS channels and reports all changes via interrupt to the μ P.

The MF and CS channel functions are inseparably linked to each other such that an MF channel must always be followed by a CS channel in the next following CFI time slot. An MF channel must furthermore, be located on an even CFI time slot, the associated CS channel must consequentially be always located on the following odd time slot.

5.5.1 Initialization of Preprocessed Channels

The initialization of preprocessed channels is usually performed after the CM reset sequence during device initialization. Resetting the CM sets all CFI time slots to unassigned channels (CM code '0000'). The initialization of preprocessed channels consists of writing appropriate CM codes to those CFI time slots that should later be handled by the CS or MF handler.

The initialization or re-initialization of preprocessed channels can of course also be carried out during the operational phase of the device.

If the CFI shall be operated as a standard IOM-2 interface, for example, the CFI frame consists of 32 time slots, numbered from 0 to 31 (see **figure 22**).

The B channels occupy time slots 0 and 1 (IOM channel 0), 4 and 5 (IOM channel 1), 8 and 9 (IOM channel 2), and so on. The B channels are normally switched to the PCM interface and are programmed only if the actual switching function is required.

The monitor, D and C/I channels occupy time slots 2 and 3 (IOM channel 0), 6 and 7 (IOM channel 1), 10 and 11 (IOM channel 2), and so on. These time slots must be initialized in both upstream and downstream directions for the desired functionality. In order to speed up this initialization, the EPIC can be set into the CM initialization mode as described in **chapter 5.3.2**.

There are several options available to cover the different applications like switched D channel, 6 bit signaling, etc. It should be noted that each pair of time slots can individually be set for a specific application and that the up- and downstream directions can also be set differently, if required.

Decentral D-Channel Handling Scheme

This option applies for IOM channels where the even time slot consists of an 8 bit monitor channel and the odd time slot of a 2 bit D-Channel followed by a 4 bit C/I channel followed by the 2 monitor handshake bits MR and MX.

The monitor channel is handled by the MF handler according to the selection of handshake or non-handshake protocol. If the handshake option is selected (IOM-2), the MF handler controls the MR and MX bits according to the IOM-2 specification. If the no handshake option is selected (IOM-1), the MF handler sets both MR and MX bits to logical 1; the MR and MX bit positions can then, if required, be accessed together with the 4 bit C/I field via the even control memory address.

The D-Channel is not processed at all, i.e. the input in upstream direction is ignored and the output in downstream direction is set to high impedance. External D-Channel controllers, e.g. 2 × IDECs PEB 2075, can then be connected to each IOM interface in order to realize **decentral D-Channel** processing.

The 4 bit C/I channel can be accessed by the μ P for controlling layer-1 devices. In upstream direction each change in the C/I value is reported by interrupt to the μ P and the CFI time slot address is stored in the CIFIFO (refer to **chapter 5.5.2**). A C/I change is

detected if the value of the current CFI frame is different from the value of the previous frame i.e. after at most 125 μ s.

To initialize two consecutive CFI time slots for the decentral D Channel handling scheme, the CM codes as given in **table 27** must be used.

Table 27

| CM Address | CM Code | CM Data |
|---------------------------|---------|------------------------|
| Even time slot downstream | 1000 | 11 C/I 11 _B |
| Odd time slot downstream | 1011 | XXXXXXXX _B |
| Even time slot upstream | 1000 | XX C/I XX _B |
| Odd time slot upstream | 0000 | XXXXXXXX _B |

Application hint: If the D-Channel is idle and if it is required to transmit a 2 bit idle code in the D-Channel (e.g. during the layer-1 activation or for testing purposes), the 6 bit signaling handling scheme can be selected for the downstream direction. The 2 D bits together with the 4 C/I bits can then be written to via the even control memory address. If the high impedance state is needed again, the decentral D-Channel scheme has to be selected again.

Example

In CFI mode 0, time slots 2 and 3 of port 3 are to be initialized for decentral D-Channel handling:

```

W:MADR = 1100 0011B ; C/I value '0000'
W:MAAR = 0000 1110B ; downstream even TS, port 3 time slot 2
W:MACR = 0111 1000B ; write CM code + data fields, CM code '1000'
W:MADR = XXXX XXXXB ; don't care
W:MAAR = 0000 1111B ; downstream odd TS, port 3 time slot 3
W:MACR = 0111 1011B ; write CM code + data fields, CM code '1011'
W:MADR = 1111 1111B ; expected C/I value '1111'
W:MAAR = 1000 1110B ; upstream even TS, port 3 time slot 2
W:MACR = 0111 1000B ; write CM code + data fields, CM code '1000'
W:MADR = XXXX XXXXB ; don't care
W:MAAR = 1000 1111B ; upstream odd TS, port 3 time slot 3
W:MACR = 0111 0000B ; write CM code + data fields, CM code '0000'
    
```

After these programming steps, the control memory will have the following content:

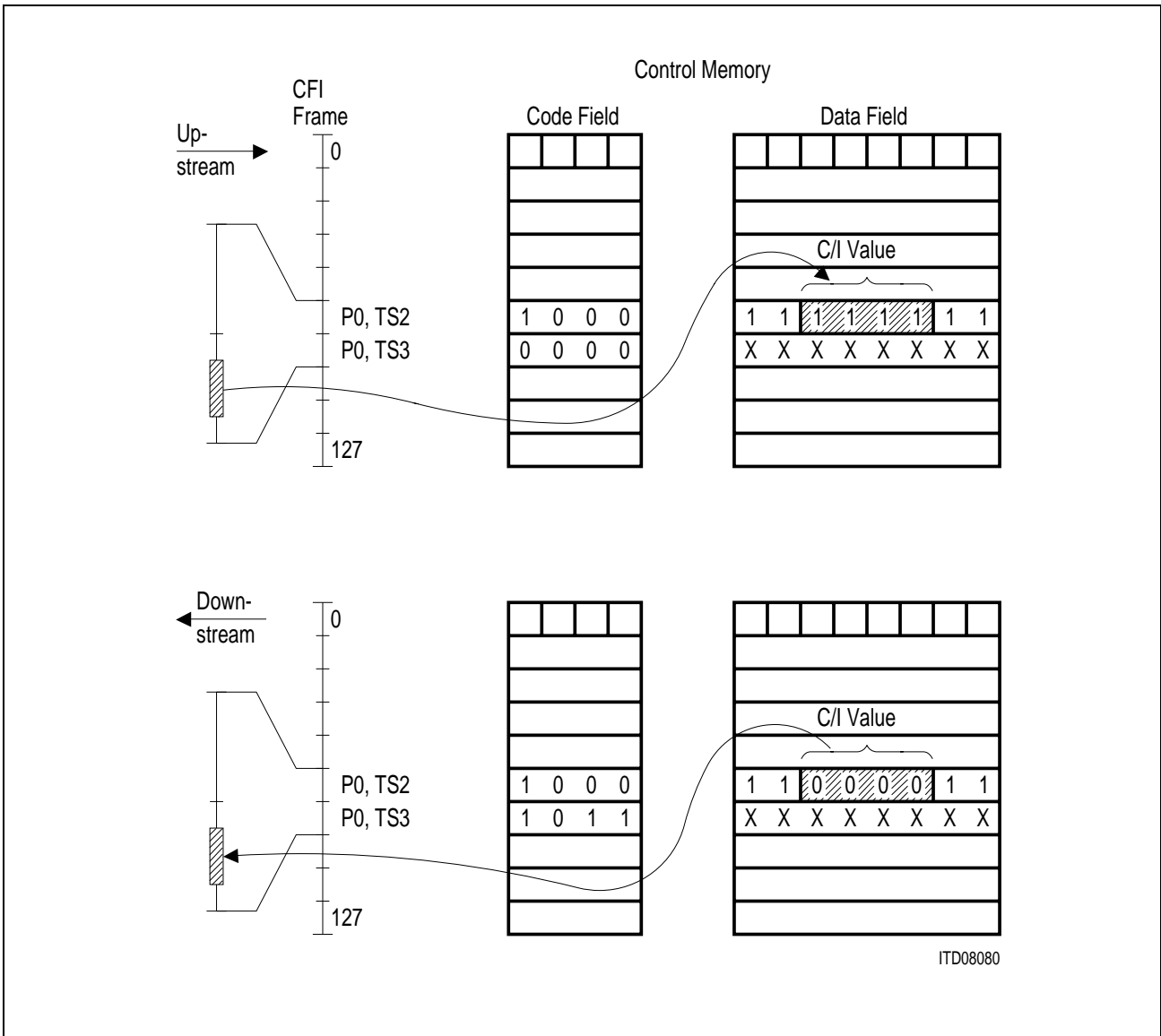

Figure 65
Control Memory Contents for Decentral D-Channel Handling

Central D-Channel Handling Scheme

This option applies for IOM channels where the even time slot consists of an 8 bit monitor channel and the odd time slot of a 2 bit D-Channel followed by a 4 bit C/I channel followed by the 2 monitor handshake bits MR and MX.

The monitor channel is handled by the MF handler according to the selected protocol, handshake or non-handshake. If the handshake option is selected (IOM-2), the MF handler controls the MR and MX bits according to the IOM-2 specification. If the non-handshake option is selected (IOM-1), the MF handler sets both MR and MX bits to

Application Hints

logical 1; the MR and MX bit positions can then, if required, be accessed together with the 4 bit C/I field via the even control memory address.

The D-Channel can be switched as a 16 kbit/s channel to and from the PCM interface in order to be handled by a **centralized D-Channel** processing unit.

The 4 bit C/I channel can be accessed by the μ P for controlling layer-1 devices. In the upstream direction each change in the C/I value is reported by interrupt to the μ P and the CFI time slot address is stored in the CIFIFO (refer to **chapter 5.5.2**). A C/I change is detected if the value of the current CFI frame is different from the value of the previous frame i.e. after at most 125 μ s.

To initialize two consecutive CFI time slots for the decentral D-Channel handling scheme, the CM codes as given in **table 28** must be used.

Table 28

| CM Address | CM Code | CM Data |
|---------------------------|----------------|------------------------|
| Even time slot downstream | 1010 | 11 C/I 11 _B |
| Odd time slot downstream | Switching code | Pointer to PCM TS |
| Even time slot upstream | 1000 | XX C/I XX _B |
| Odd time slot upstream | Switching code | Pointer to PCM TS |

The switching codes specify the PCM subtime slot positions of the 16 kbit/s transfer. Note that the 2 D bits are always located on bits 7 ... 6 of a CFI time slot, the CSCR:SC#1, SC#0 bits must therefore be set to 00 (see **chapter 5.4.2**).

Table 29

| Transferred Channel PCM Bit Positions | Downstream CM Codes | Upstream CM Codes |
|---------------------------------------|---------------------|-------------------|
| Unassigned channel | 1011 ¹⁾ | 0000 |
| 16 kbit/s/ bits 7 ... 6 | 0111 | 0111 |
| 16 kbit/s/ bits 5 ... 4 | 0110 | 0110 |
| 16 kbit/s/ bits 3 ... 2 | 0101 | 0101 |
| 16 kbit/s/ bits 1 ... 0 | 0100 | 0100 |

¹⁾ This code sets the D bits to high impedance

- Application hints:
- 1) If the D channel is idle and if it is required to transmit a 2 bit idle code in the D channel (e.g. during the layer-1 activation or for testing purposes), the 6 bit signaling handling scheme can be selected for the downstream direction. The 2 D bits together with the 4 C/I bits can then be written to via the even control memory address. If the high impedance state is needed again, the decentral D channel scheme has to be selected again.
 - 2) The central D channel scheme has primarily been designed to switch the 16 kbit/s D channel to the PCM interface and to process the C/I channel by the local μ P. For some applications however, it is advantageous to switch the 2 D bits together with the 4 C/I bits transparently to and from the PCM interface. The monitor channel shall, however, still be handled by the internal MF handler. This function might be useful if two layer-1 transceivers, operated in "Repeater Mode", shall be connected via a PCM link. For these applications, the odd control memory address is written with the 64 kbit/s switching code '0001', the CM data field pointing to the desired PCM time slot. Since also the MR and MX bits are being switched, these must be carefully considered: in upstream direction the two least significant bits of the PCM time slot can be set to high impedance via the tristate field; in downstream direction the two least significant bits of the PCM time slot must be received at a logical 1 level since these bits will be logical ANDed at the CFI with the downstream MR and MX bits generated by the MF handler.

Example

In CFI and PCM modes 0, CFI time slots 10 and 11 of port 1 shall be initialized for central D channel handling, the downstream D channel shall be switched from PCM port 0, TS5, bits 5 ... 4 and the upstream D channel shall be switched to PCM port 2, TS8, bits 3 ... 2:

| | | | | |
|--------|---|------------------------|---|---|
| W:MADR | = | 1100 0011 _B | ; | C/I value '0000' |
| W:MAAR | = | 0010 1010 _B | ; | downstream even TS, port 1 time slot 10 |
| W:MACR | = | 0111 1010 _B | ; | write CM code + data fields, CM code '1010' |
| W:MADR | = | 0001 0001 _B | ; | pointer to PCM port 0, TS5 |
| W:MAAR | = | 0010 1011 _B | ; | downstream odd TS, port 1 time slot 11 |
| W:MACR | = | 0111 0110 _B | ; | write CM code + data fields, CM code '0110' |
| W:MADR | = | 1111 1111 _B | ; | expected C/I value '1111' |
| W:MAAR | = | 1010 1010 _B | ; | upstream even TS, port 1 time slot 10 |
| W:MACR | = | 0111 1000 _B | ; | write CM code + data fields, CM code '1000' |

Application Hints

W:MADR = 1010 0100_B ; pointer to PCM port 2, TS8
 W:MAAR = 1010 1011_B ; upstream odd TS, port 1 time slot 11
 W:MACR = 0111 0101_B ; write CM code + data fields, CM code '0101'
 W:MADR = 0000 0010_B ; set bits 3 ... 2 to low Z and rest of time slot to high Z
 W:MAAR = 1010 0100_B ; pointer to PCM port 2, TS8
 W:MACR = 0110 0000_B ; write DM CF, single channel tristate command

After these programming steps, the EPIC memory will have the following contents:

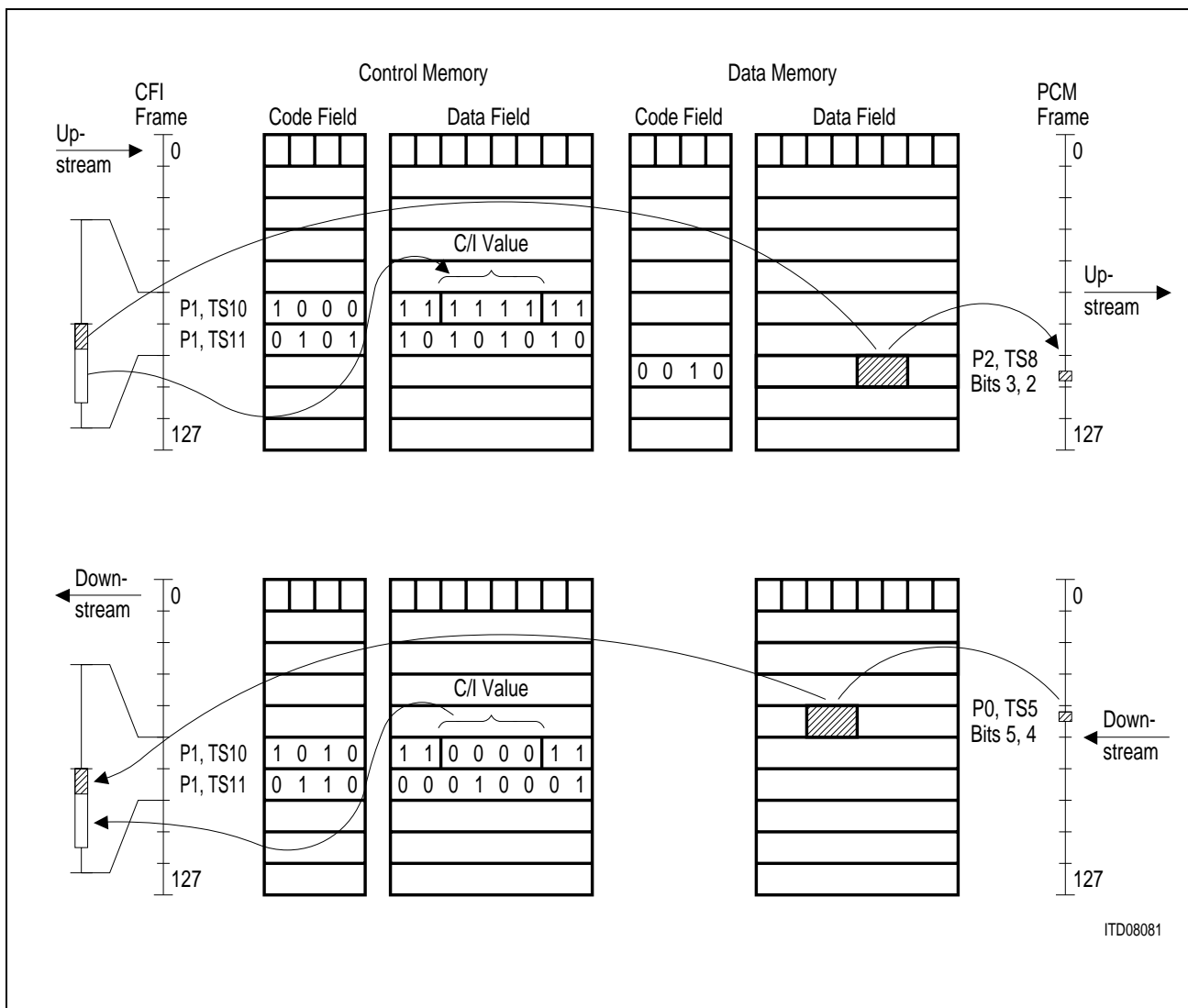

Figure 66
Control Memory Contents for Central D-Channel Handling

6-Bit Signaling Channel Scheme

This option is intended for IOM channels where the even time slot consists of an 8 bit monitor channel and the odd time slot of a 6 bit signaling channel followed by the 2 monitor handshake bits MR and MX.

The monitor channel is handled by the MF handler according to the selected protocol, handshake or non-handshake. If the handshake option is selected (IOM-2), the MF handler controls the MR and MX bits according to the IOM-2 specification. If the non-handshake option is selected (IOM-1), the MF handler sets both MR and MX bits to logical 1; the MR and MX bit positions can then, if required, be accessed together with the 6 bit SIG field via the even control memory address.

The 6 bit SIG channel can be accessed by the μ P for controlling codec filter devices. In upstream direction each valid change in the SIG value is reported by interrupt to the μ P and the CFI time slot address is stored in the CIFIFO (refer to **chapter 5.5.2**). The change detection mechanism consists of a double last look logic with a programmable period.

To initialize two consecutive CFI time slots for the 6 bit signaling channel scheme, the CM codes as given in **table 30** must be used:

Table 30

| CM Address | CM Code | CM Data |
|---------------------------|----------------|------------------------------|
| Even time slot downstream | 1010 | SIG 11 _B |
| Odd time slot downstream | 1011 | XXXXXXXX _B |
| Even time slot upstream | 1010 | actual value XX _B |
| Odd time slot upstream | 1010 | stable value XX _B |

Application hint: For some applications it is useful to switch the 6 SIG bits transparently to and from the PCM interface. The monitor channel shall, however, still be handled by the internal MF handler. For this purpose, a slightly modified central D channel scheme can be used. This mode, which has primarily been designed to switch the 16 kbit/s D channel to the PCM interface, can be modified as follows: the odd control memory address is written with the 64 kbit/s switching code "0001", the CM data field pointing to the desired PCM time slot. Since the MR and MX bits are being switched, these must be carefully considered: in upstream direction the two least significant bits of the PCM time slot can be set to high impedance via the tristate field; in downstream direction the two least significant bits of the PCM time slot must be received at a logical 1 level since these bits will be logical ANDed at the CFI with the downstream MR and MX bits generated by the MF handler.

Example

In CFI mode 0, time slots 2 and 3 of port 0 shall be initialized for 6 bit signaling channel handling:

```

W:MADR = 0100 0111B ; SIG value "010001"
W:MAAR = 0000 1000B ; downstream even TS, port 0 time slot 2
W:MACR = 0111 1010B ; write CM code + data fields, CM code "1010"
W:MADR = XXXX XXXXB ; don't care
W:MAAR = 0000 1001B ; downstream odd TS, port 0 time slot 3
W:MACR = 0111 1011B ; write CM code + data fields, CM code "1011"
W:MADR = 1101 1111B ; expected SIG value "110111"
W:MAAR = 1000 1000B ; upstream even TS, port 0 time slot 2
W:MACR = 0111 1010B ; write CM code + data fields, CM code "1010"
W:MADR = 1101 1111B ; expected SIG value "110111"
W:MAAR = 1000 1001B ; upstream odd TS, port 0 time slot 3
W:MACR = 0111 1010B ; write CM code + data fields, CM code "1010"
    
```

After these programming steps, the EPIC memory will have the following contents:

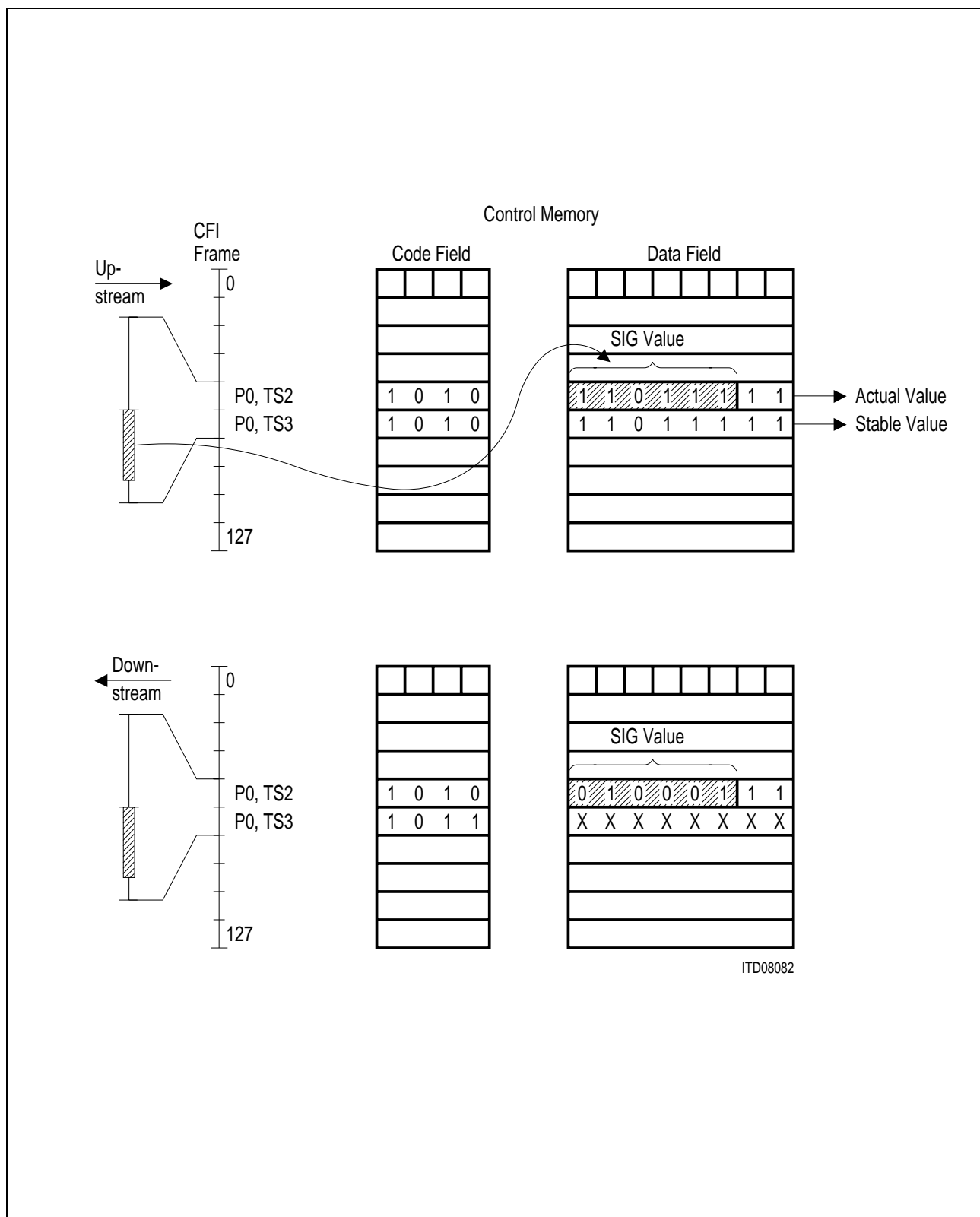

Figure 67
Control Memory Contents for 6-Bit Signaling Channel Handling

8-Bit Signaling Scheme

This option is intended for SLD channels where the even time slot consists of an 8 bit feature control channel and the odd time slot of an 8 bit signaling channel.

The feature control channel is handled by the MF handler according to the selected protocol, handshake or non-handshake. Note that only the non-handshake mode makes sense in SLD applications.

The 8 bit SIG channel can be accessed by the μ P for controlling codec filter devices. In upstream direction each valid change in the SIG value is reported by interrupt to the μ P and the CFI time slot address is stored in the CIFIFO (refer to **chapter 5.5.2**). The change detection mechanism consists of a double last look logic with a programmable period.

To initialize two consecutive CFI time slots for the 8 bit signaling channel scheme, the CM codes as given in **table 31** must be used:

Table 31

| CM Address | CM Code | CM Data |
|---------------------------|----------------|---------------------------|
| Even time slot downstream | 1010 | SIG _B |
| Odd time slot downstream | 1011 | XXXXXXXX _B |
| Even time slot upstream | 1011 | actual value _B |
| Odd time slot upstream | 1011 | stable value _B |

Example

In CFI mode 3, downstream time slots 2 and 3 and upstream time slots 6 and 7 of port 0 shall be initialized for 8 bit signaling channel handling:

```

W:MADR = 0100 0101B ; SIG value "0100 0101"
W:MAAR = 0001 0000B ; downstream even TS, port 0 time slot 2
W:MACR = 0111 1011B ; write CM code + data fields, CM code "1011"
W:MADR = XXXX XXXXB ; don't care
W:MAAR = 0001 0001B ; downstream odd TS, port 0 time slot 3
W:MACR = 0111 1011B ; write CM code + data fields, CM code "1011"
W:MADR = 1101 0110B ; expected SIG value "1101 0110"
W:MAAR = 1011 0000B ; upstream even TS, port 0 time slot 6
W:MACR = 0111 1011B ; write CM code + data fields, CM code "1011"
W:MADR = 1101 0110B ; expected SIG value "1101 0110"
W:MAAR = 1011 0001B ; upstream odd TS, port 0 time slot 7
W:MACR = 0111 1011B ; write CM code + data fields, CM code "1011"
    
```

Summary of “Preprocessed Channel” Codes

| DD Application | Even Control Memory Address MAAR = 0.....0 | | Odd Control Memory Address MAAR = 0.....1 | | Output at the Configurable Interface Downstream Preprocessed Channels | |
|--|---|----------------------------|--|----------------------------|--|---|
| | Code Field MACR = 0111... | Data Field MADR = | Code Field MACR = 0111... | Data Field MADR = | Even Time-Slot | Odd Time-Slot |
| Decentral D Channel Handling | 1 0 0 0 | 1 1 C/I 1 1 | 1 0 1 1 | X X X X X X X X | m m m m m m m m - - C/I m m | Monitor Channel Control Channel |
| Central D Channel Handling | 1 0 1 0 | 1 1 C/I 1 1 | PCM Code for a 2 Bit Sub. Time-Slot | Pointer to a PCM Time-Slot | m m m m m m m m D D C/I m m | Monitor Channel Control Channel |
| 6 Bit Signaling (e.g. analog IOM [®]) | 1 0 1 0 | SIG 1 1 | 1 0 1 1 | X X X X X X X X | m m m m m m m m SIG m m | Monitor Channel Control Channel |
| 8 Bit Signaling (e.g. SLD) | 1 0 1 0 | SIG | 1 0 1 1 | X X X X X X X X | m m m m m m m m SIG | Feature Control Channel Signaling Channel |

| DD Application | Even Control Memory Address MAAR = 1.....0 | | Odd Control Memory Address MAAR = 1.....1 | | Input from the Configurable Interface Upstream Preprocessed Channels | |
|--|---|----------------------------|--|----------------------------|---|---|
| | Code Field MACR = 0111... | Data Field MADR = | Code Field MACR = 0111... | Data Field MADR = | Even Time-Slot | Odd Time-Slot |
| Decentral D Channel Handling | 1 0 0 0 | 1 1 C/I 1 1 | 0 0 0 0 | X X X X X X X X | m m m m m m m m - - C/I m m | Monitor Channel Control Channel |
| Central D Channel Handling | 1 0 0 0 | 1 1 C/I 1 1 | PCM Code for a 2 Bit Sub. Time-Slot | Pointer to a PCM Time-Slot | m m m m m m m m D D C/I m m | Monitor Channel Control Channel |
| 6 Bit Signaling (e.g. analog IOM [®]) | 1 0 1 0 | SIG Actual Value X X | 1 0 1 0 | SIG Stable Value X X | m m m m m m m m SIG m m | Monitor Channel Control Channel |
| 8 Bit Signaling (e.g. SLD) | 1 0 1 1 | SIG Actual Value | 1 0 1 1 | SIG Stable Value | m m m m m m m m SIG | Feature Control Channel Signaling Channel |

m : Monitor channel bits, these bits are treated by the monitor/feature control handler

- : Inactive sub. time-slot, in downstream direction these bits are tristated (OMDR : COS = 0) or set to logical 1 (OMDR : COS = 1)

C/I : Command/Indication channel, these bits are exchanged between the CFI in/output and the CM data field. A change of the C/I bits in upstream direction causes an interrupt (ISTA : SFI). The address of the change is stored in the CIFIFO

D : D channel, these D channel bits are transparently switched to and from the PCM interface.

SIG : Signaling Channel, these bits are exchanged between the CFI in/output and the CM data field. The SIG value which actual value was present in the last frame is stored as the actual value in the even address CM location. The stable value is updated stable value if a valid change in the actual value has been detected according to the last look algorithm. A change of the SIG stable value in upstream direction causes an interrupt (ISTA : CFI). The address of the change is stored in the CIFIFO.

ITD09544

Figure 68
Pre-processed Channel Codes

5.5.2 Control/Signaling (CS) Handler

If the configurable interface (CFI) of the EPIC is operated as IOM or SLD interface, it is necessary to communicate with the connected subscriber circuits such as layer-1 transceivers (ISDN line cards) or codec filter devices (analog line cards) over the Command/Indication (C/I) or the signaling (SIG) channel. In order to simplify this task the EPIC has implemented the **Control/Signaling Handler** (CS Handler).

In downstream direction, the 4, 6 or 8 bit C/I or SIG value can simply be written to the Control Memory data field which will then be repeatedly transmitted in every frame to the subscriber circuit until a new value is loaded.

Note that the downstream C/I or SIG value must always be written to the **even** CM address in order to be transmitted in the subsequent **odd** CFI time slot!

In upstream direction a change detection mechanism is active to search for changes in the received C/I or SIG values. Upon a change, the address of the involved subscriber is stored in a 9 byte deep FIFO (CIFIFO) and an interrupt (ISTA:SFI) is generated. The μ P can then first determine the CM address by reading the FIFO before reading the new C/I or SIG value out of the Control Memory. The address FIFO serves to increase the latency time for the μ P to react to SFI interrupts. If several C/I or SIG changes occur before the μ P executes the SFI interrupt handling routine, the addresses of the first 9 changes are stored in the CIFIFO and the corresponding C/I or SIG values are stored in the control memory (CM). If more than 9 changes occur before the μ P reads the CIFIFO, these additional changes are no longer updated in the control memory. This is to prevent any loss of change information. These additional changes remain pending at the serial interface. As soon as the μ P reads the CIFIFO, and thus, empties locations of the FIFO, these pending changes are sequentially written to the CM and the corresponding addresses to the FIFO. It is thus ensured that no change information is lost even if, for example, all 32 subscribers simultaneously generate a change in their C/I or SIG channel!

CFI time slots which should be processed by the CS handler must first be initialized as MF/CS channels with appropriate codes in the Control Memory code field (refer to **chapter 5.5.1**).

5.5.2.1 Registers used in Conjunction with the CS Handler

In detail, the following register bits are used in conjunction with the CS handler:

Signaling FIFO read reset value: 0XXXXXXX_B

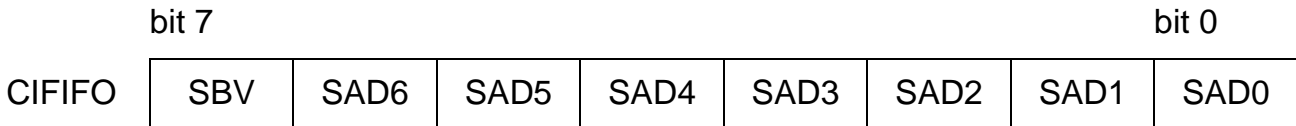

The 9 byte deep CIFIFO stores the addresses of CFI time slots in which a C/I and/or a SIG value change has taken place. This address information can then be used to read the actual C/I or SIG value from the Control Memory.

SBV: Signaling Byte Valid; if SBV = 1, the SAD6 ... 0 bits indicate a valid subscriber address. The polarity of SBV is chosen such that the whole 8 bits of the CIFIFO can be copied to the MAAR register in order to read the upstream C/I or SIG value from the Control Memory.

SAD6 ... 0: Subscriber Address bits 6 ... 0; The CM address which corresponds to the CFI time slot where a C/I or SIG value change has taken place is encoded in these bits. For C/I channels SAD6 ... 0 point to an even CM address (C/I value), for SIG channels SAD6 ... 0 point to an odd CM address (stable SIG value).

Timer Register write reset value: 00_H

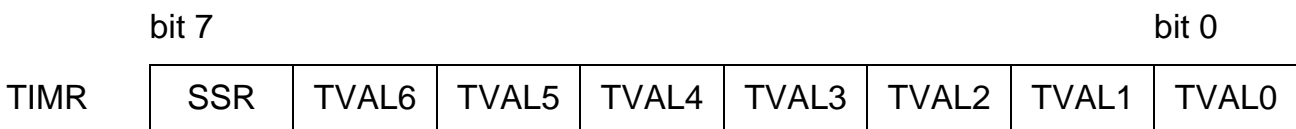

The EPIC timer can be used for 3 different purposes: timer interrupt generation (ISTA:TIG), FSC multiframe generation (CMD2:FC2 ... 0 = 111), and last look period generation.

In case of last look period generation, the following functions are provided:

SSR: Signaling Sampling Rate; If SSR = 1, the last look period is fixed to 125 μs, i.e. the timer is not used at all for the last look logic. The value programmed to TVAL has then no influence on the last look period. The timer can then still be used for timer interrupt generation, and/or FSC multiframe generation, with a period as defined by TVAL6 ... 0. If SSR = 0, the last look period is defined by TVAL6 ... 0. Note that if the timer is used, it must also be started with CMDR:ST = 1.

Application Hints

TVAL6 ... 0: Timer Value bits 6 ... 0; the timer period, equal to $(1 + TVAL6 \dots 0) \times 250 \mu s$, is programmed here. It can thus be adjusted within the range of 250 μs up to 32 ms.

The timer is started as soon as CMDR:ST is set to 1 and stopped by writing the TIMR register or by selecting OMDR:OMS0 = 0.

If the timer is used to generate the last look period, it can still be used for timer interrupt generation and/or FSC multiframe generation if it is acceptable that all three applications use the same timer value.

Command Register write reset value: 00_H

| | | | | | | | | |
|------|-------|-----------|-----|------------|------|------|-------|------|
| | bit 7 | | | | | | bit 0 | |
| CMDR | 0 | ST | TIG | CFR | MFT1 | MFT0 | MFSO | MFFR |

Writing a logical 1 to a CMDR register bit starts the respective operation.

The signaling handler uses two command bits:

ST: Start Timer; must be set to 1 if the last look period is defined by TIMR:TVAL6 ... 0, i.e. if TIMR:SSR = 0. Note that if TIMR:SSR = 1, the timer need not be started.

CFR: CIFIFO Reset; setting CFR to logical 1 resets the signaling FIFO within 2 RCL periods, i.e. all entries and the ISTA:SFI bit are cleared.

Status Register read reset value: 05_H

| | | | | | | | | |
|------|-------|------------|-----|------|------|------|-------|------|
| | bit 7 | | | | | | bit 0 | |
| STAR | MAC | TAC | PSS | MFT0 | MFAB | MFAE | MFRW | MFFE |

The status register STAR displays the current state of certain events within the EPIC. The STAR register bits do not generate interrupts and are not modified by reading STAR.

The following bit is indirectly used by the signaling handler:

TAC: Timer Active; the timer is running if TAC is set to logical 1, the timer is not running if TAC is set to logical 0.

Note: The timer is only necessary for signaling channels (not C/I) and when using a last look period greater or equal to 250 μs .

Application Hints

Interrupt Status Register read reset value: 00_H

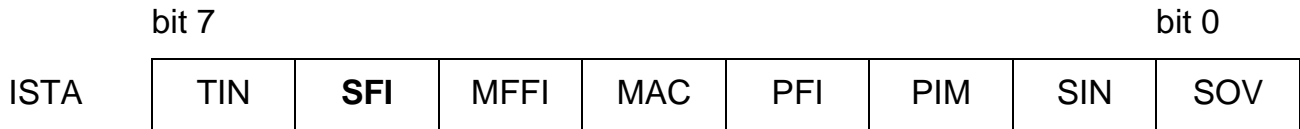

The ISTA register should be read after an interrupt in order to determine the interrupt source.

In connection with the signaling handler one maskable (MASK) interrupt bit is provided by the EPIC in the ISTA register:

SFI: Signaling FIFO Interrupt; This bit is set to logical 1 if there is at least one valid entry in the CIFIFO indicating a change in a C/I or SIG channel. Reading ISTA does not clear the SFI bit. Instead SFI is cleared (logical 0) if the CIFIFO is empty which can be accomplished by reading all valid entries of the CIFIFO or by resetting the CIFIFO by setting CMDR:CFR to 1.

Note: The MASK:SFI bit only disables the interrupt pin (\overline{INT}); the ISTA:SFI bit will still be set to logical 1.

5.5.2.2 Access to Downstream C/I and SIG Channels

If two consecutive downstream CFI time slots, starting with an even time slot number, are programmed as MF and CS channels, the μ P can write a 4, 6 or 8 bit wide C/I or SIG value to the even addressed downstream CM data field. This value will then be transmitted repeatedly in the odd CFI time slot until a new value is loaded.

This value, first written into MADR, can be transferred to the CM data field using the memory operation codes MACR:MOC = 111X or MACR:MOC = 1001 (refer to **chapter 5.3.3.3**).

The code MACR:MOC = 111X applies if the code field has not yet been initialized with a CS channel code. Writing to MACR with MACR:RWS = 0 will then copy the CS channel code written to MACR:CMC3 ... CMC0 to the CM code field and the value written to MADR to the CM data field. The CM address (CFI time slot) is specified by MAAR according to **figure 48**.

The code MACR:MOC = 1001 applies if the code field has already been properly initialized with a CS channel code. In this case only the MADR content will be copied to the CM data field addressed by MAAR.

The value written to MADR should have the following format:

4 bit C/I value: MADR = 1 1 _ _ _ _ 1 1_B

6 bit SIG value: MADR = _ _ _ _ _ _ 1 1_B

8 bit SIG value: MADR = _ _ _ _ _ _ _ _ B

Examples

In CFI mode 0 the downstream time slots 6 and 7 of port 2 shall be initialized as MF and CS channels, 6 bit signaling scheme. The initialization value shall be '010101':

```

W:MADR = 0101 0111B ; SIG value '010101'
W:MAAR = 0001 1100B ; downstream, port 2, time slot 6
W:MACR = 0111 1010B ; write CM code + data fields, CM code '1010'
W:MADR = XXXX XXXXB ; don't care
W:MAAR = 0001 1101B ; downstream, port 2, time slot 7
W:MACR = 0111 1011B ; write CM code + data fields, CM code '1011'
    
```

The above programming sequence can for example be performed during the initialization phase of the EPIC. Once the CFI time slots have been loaded with the appropriate codes ('1010' in time slot 6 and '1011' in time slot 7), an access to the downstream SIG channel (time slot 7) can be accomplished simply by writing a new value to the address of time slot 6:

```

W:MADR = 1100 1111B ; new SIG value '110011'
W:MAAR = 0001 1100B ; downstream, port 2, time slot 6
W:MACR = 0100 1000B ; write CM DF, MOC = 1001
    
```

5.5.2.3 Access to the Upstream C/I and SIG Channels

If two consecutive upstream CFI time slots, starting with an even time slot number, are programmed as MF and CS channels, the μ P can read the received 4, 6 or 8 bit C/I or SIG values simply by reading the upstream CM data field.

Two cases can be distinguished:

When a 4 bit Command/Indication handling scheme is selected, the C/I value received in the odd CFI time slot can be read from the even CM address. This value is sampled in each frame (every 125 μ s). Each change is furthermore indicated by an ISTA:SFI interrupt and the address of the corresponding even CM location is stored in the CIFIFO. Since the MSB of the CIFIFO is set to 1 for a valid entry (SBV = 1), the value read from the CIFIFO can directly be copied to MAAR in order to read the upstream CM data field which also requires an MSB set to 1 ($U/\bar{D} = 1$).

When a 6 or 8 bit signaling scheme is selected, the received SIG value is sampled at intervals of 125 μ s or $(TVAL + 1) \times 250 \mu$ s and stored as the "actual value" at the even CM address. The μ P can access the actual value simply by reading this even CM data field location. Additionally, a "stable value", based on the double last look algorithm is generated: in order to assure that erroneous bit changes at the sampling time point do

not initiate a definite change, the values of two consecutive sampling points are compared with the current old stable value. The stable value is then only updated if both new values are identical and differ from the old stored value. The stable value can be read from the odd CM data field location. Each change in the stable value is furthermore indicated by an ISTA:SFI interrupt and the address of the corresponding odd CM location is stored in the CIFIFO. Since the MSB of the CIFIFO is set to 1 for a valid entry (SBV = 1), the value read from the CIFIFO can directly be copied to MAAR in order to read the upstream CM data field, which also requires an MSB set to 1 ($U/\overline{D} = 1$).

*Note: The sampling interval is selected in the TIMR register (refer to **chapter 5.5.2.1**). If the sampling interval is set to 125 μ s (TIMR:SSR = 1), it is not necessary to start the timer to operate the change detection logic. If, however, the last look period is determined by TIMR:TVAL6 ... 0 (TIMR:SSR = 0) it is required to start the timer (CMDR:ST = 1) to operate the change detection logic and to generate SFI interrupts.*

Examples

In CFI mode 0 the upstream time slots 6 and 7 of port 2 shall be initialized as MF and CS channels, 6 bit signaling scheme, the expected value from the codec after power up shall be "011101":

```
W:MADR = 0111 0111B ; expected actual value "011101"
W:MAAR = 1001 1100B ; upstream, port 2, time slot 6
W:MACR = 0111 1010B ; write CM code + data fields, CM code "1010"
W:MADR = 0111 0111B ; expected stable value "011101"
W:MAAR = 1001 1101B ; upstream, port 2, time slot 7
W:MACR = 0111 1010B ; write CM code + data fields, CM code "1010"
```

The above programming sequence can for example be performed during the initialization phase of the EPIC. At this stage the CFI is not operational (OMDR = 80 μ), i.e. the values received at the CFI are ignored.

If the expected value "011101" is actually received upon activation of the CFI (e.g. OMDR = EE_H), no interrupt will be generated at this moment. But the change detection is now enabled and each valid change in the received SIG value (e.g. new value "001100") will generate an interrupt, with the address being stored in the CIFIFO. The reaction of the μ P to such an event would then look like this:

```
R:ISTA    = 0100 0000B    ; SFI interrupt
R:CIFIFO  = 1001 1101B    ; address of upstream, port 2, time slot 7
W:MAAR    = 1001 1101B    ; copy the address from CIFIFO to MAAR
W:MACR    = 1100 1000B    ; read back command for CM DF, MOC = 1001
wait for STAR:MAC = 0
R:MADR    = 0011 00XXB    ; read new SIG value (e.g. 001100)
wait for further ISTA:SFI interrupts
```

5.5.3 Monitor/Feature Control (MF) Handler

If the configurable interface CFI of the EPIC is configured as IOM or SLD interface, it is necessary to communicate with the connected subscriber circuits such as layer-1 transceivers (ISDN line cards) or codec filter devices (analog line cards) over the monitor channel (IOM) or feature control channel (SLD). In order to simplify this task the EPIC has implemented the **Monitor/Feature Control (MF) Handler** which autonomously controls and supervises the data transfer via these channels.

The communication protocol used in an MF channel is interface and subscriber circuit specific.

Three cases can be distinguished:

IOM[®]-2 Interface Protocol

In this case the monitor channel protocol is a handshake procedure used for high speed information exchange between the EPIC and other devices such as the IEC-Q (PEB 2091), SBCX (PEB 2081) or SICOFI2 (PEB 2260).

The monitor channel operates on an asynchronous basis. While data transfers on the IOM-2 interface take place synchronized to the IOM frame, the flow of data is controlled by a handshake procedure based on the monitor channel receive (MR) and the monitor channel transmit (MX) bits located at the end of the fourth time slot of the respective IOM-2 channel.

For the transmission of a data byte for example, the data is placed onto the downstream monitor channel and the MX bit is activated. This byte will then be transmitted repeatedly once per 8 kHz frame until the receiver acknowledges the transfer via the upstream MR bit.

A detailed description of the IOM-2 monitor channel operation can be found in the "IOM-2 Interface Reference Guide".

IOM[®]-1 Interface Protocol

In this case the monitor channel protocol is a non handshake procedure which can be used to exchange one byte of information at a time between the EPIC and a layer-1 device such as the IBC (PEB 2095) or the IEC-T (PEB 2090).

Data bytes to be transmitted are sent once in the downstream monitor channel. Since the monitor channel is idle (FF_H) when no data is being transmitted, the receiving device accepts only valid data bytes which are different from FF_H . If a message shall be sent back to the EPIC, this must occur in the frame following the frame of reception.

SLD Interface Protocol

The transfer of control information over the feature control channel of an SLD interface e.g. for programming the coefficients to a SICOFI (PEB 2060) device is also performed without a handshake procedure. Data is transmitted and received synchronous to the 8 kHz frame at a speed of one data byte per frame.

The MF handler of the EPIC supports all three kinds of protocols. A bidirectional 16 byte FIFO, the MFFIFO, serves as data buffer for outgoing and incoming MF messages in all protocol modes. This implies that the MF communication is always performed on a half-duplex basis.

Differentiation between IOM-2 and IOM-1/SLD modes is made via the MF Protocol Selection bit **MFPS** in the Operation Mode Register **OMDR**.

Since the IOM-1 and SLD protocols are very similar, they are treated by the EPIC in exactly the same way i.e. without handshake protocol. The only processing difference concerns the involved upstream time slot when receiving data:

When configured as IOM interface (CFI modes 0, 1 or 2), the CFI ports consist of separate upstream (DU) and downstream (DD) lines. In this case MF data is transmitted on DD and received on DU of the **same CFI time slot**.

When configured as SLD interface (CFI mode 3), the CFI ports consist of bidirectional lines (SIP). The first four time slots of the frame are used as downstream time slots and the last four as upstream time slots. In this case the MF data is transmitted in the downstream feature control time slot and received on the **same CFI line** but four time slots later in the upstream feature control time slot.

CFI time slots which should be processed by the MF handler must first be initialized as MF/CS channels with appropriate codes in the Control Memory Code Field (refer to **chapter 5.5.1**).

Except for broadcast operation, communication over the MF channel is only possible with one subscriber circuit at a time. The MF handler must therefore be pointed to that particular time slot via the address register **MFSAR**.

Normally MF channel transfers are initiated by the EPIC (master). The subscriber circuits (slaves) will only send back monitor messages upon a request from the master device.

In IOM-2 applications, however, (active handshake protocol), it is also possible that a slave device requests a data transfer e.g. when an IEC-Q device has received an EOC message over the U interface.

For these applications the EPIC has implemented a search mechanism that looks for active handshake bits. When such a monitor channel is found, the μ P is interrupted (ISTA:MAC) and the address of the involved MF channel is stored in a register (**MFAIR**). The MF handler can then be pointed to that channel by copying the contents of MFAIR to MFSAR and the actual message transfer can take place.

5.5.3.1 Registers used in Conjunction with the MF Handler

In detail, the following registers are involved when performing MF channel transfers:

Operation Mode Register read/write reset value: 00_H

| | | | | | | | | |
|-------|-------|------|-----|-----|-----|-------------|-----|-------|
| | bit 7 | | | | | | | bit 0 |
| OMDR: | OMS1 | OMS0 | PSB | PTL | COS | MFPS | CSB | RBS |

MFPS: MF channel Protocol Selection;
 MFPS = 0: Handshake facility disabled; to be used for SLD and IOM-1 applications.
 MFPS = 1: Handshake facility enabled; to be used for IOM-2 applications.

Monitor/Feature Control Channel FIFO read/write reset value: empty

| | | | | | | | | |
|---------|-------|------|------|------|------|------|------|-------|
| | bit 7 | | | | | | | bit 0 |
| MFFIFO: | MFD7 | MFD6 | MFD5 | MFD4 | MFD3 | MFD2 | MFD1 | MFD0 |

The 16 byte bidirectional MFFIFO provides intermediate storage for data bytes to be transmitted or received over the monitor or feature control channel.

Note: The data transfer over an MF channel is half-duplex i.e. if a “transmit + receive” command is issued, the transmit section of the transfer must first be completed before the receive section starts.

MFD7 ... 0: MF Data bits 7 ... 0; MFD7 (MSB) is the first bit to be sent over the serial CFI, MFD0 (LSB) the last.

MF Channel Subscriber Address Register write reset value: undefined

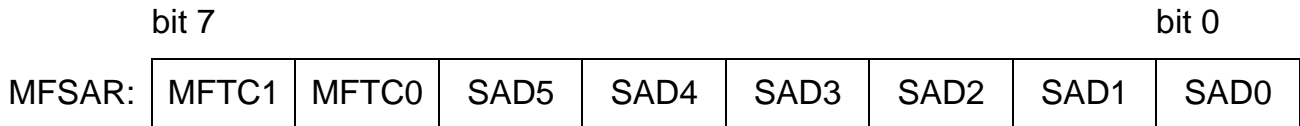

The exchange of monitor data normally takes place with only one subscriber circuit at a time. This register serves to point the MF handler to that particular CFI time slot.

MFTC1 ... 0: MF Channel Transfer Control 1 ... 0; these bits, in addition to CMDR:MFT1,0 and OMDR:MFPS control the MF channel transfer as indicated in **table 32**.

SAD5 ... 0: Subscriber address 5 ... 0; these bits define the addressed subscriber. The CFI time slot encoding is similar to the one used for Control Memory accesses using the MAAR register (see **figure 48**).

CFI time slot encoding of MFSAR derived from MAAR:

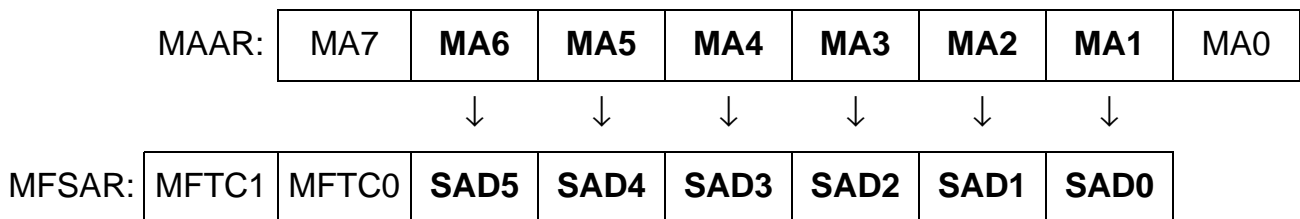

MAAR:MA7 selects between upstream and downstream CM blocks. This information is not required since the transfer direction is defined by CMDR (transmit or receive).

MAAR:MA0 selects between even and odd time slots. This information is also not required since MF channels are always located on even time slots.

Example

In CFI mode 0, IOM channel 5 (time slot 16 ... 19) of port 2 shall be addressed for a transmit monitor transfer:

MFSAR = 0010 0110_B; the monitor channel occupies time slot 18 (10010_B) of port 2 (10_B)

MF Channel Active Indication Register read reset value: undefined

| | | | | | | | | |
|--------|-------|----|------|------|------|------|------|-------|
| | bit 7 | | | | | | | bit 0 |
| MFAIR: | 0 | SO | SAD5 | SAD4 | SAD3 | SAD2 | SAD1 | SAD0 |

This register is only used in IOM-2 applications (active handshake protocol) in order to identify active monitor channels when the 'Search for active monitor channels' command (CMDR:MFSO) has been executed.

SO: MF Channel Search On; this bit indicates whether the EPIC is still busy looking for an active channel (1) or not (0).

SAD5 ... 0: Subscriber Address 5 ... 0; after an ISTA:MAC interrupt these bits point to the port and time slot where an active channel has been found. The coding is identical to MFSAR:SAD5 ... SAD0. The contents of MFAIR can directly be copied to MFSAR in order to point the MF handler to the channel which requests a monitor receive operation.

Command Register read reset value: 00_H

| | | | | | | | | |
|------|-------|----|-----|-----|-------------|-------------|-------------|-------------|
| | bit 7 | | | | | | | bit 0 |
| CMDR | 0 | ST | TIG | CFR | MFT1 | MFT0 | MFSO | MFFR |

Writing to CMDR starts the respective monitor channel operation.

MFT1 ... 0: MF Channel Transfer Control Bits 1, 0; these bits start the monitor transfer enabling the contents of the MFFIFO to be exchanged with the subscriber circuits as specified in MFSAR. The function of some commands depends furthermore on the selected protocol (OMDR:MFPS). **Table 32** summarizes all available MF commands.

MFSO: MF Channel Search On; if set to 1, the EPIC starts to search for active MF channels. Active channels are characterized by an active MX bit (logical 0) sent by the remote transmitter. If such a channel is found,

Application Hints

the corresponding address is stored in MFAIR and an ISTA:MAC interrupt is generated. The search is stopped when an active MF channel has been found or when OMDR:OMS0 is set to 0.

MFFR: MFFIFO Reset; setting this bit resets the MFFIFO and all operations associated with the MF handler (except for the search function) within 2 RCL periods. The MFFIFO is set into the state 'MFFIFO empty, write access enabled' and any monitor data transfer currently in process will be aborted. MFFR should be set when all data bytes have been read from the MFFIFO after a monitor receive operation.

Table 32

| Transfer Mode | CMDR: MFT, MFT0 | MFSAR | Protocol Selection | Application |
|--------------------------------------|--------------------|---------------|-------------------------|-------------------|
| Inactive | 00 | XXXXXXXX | HS, no HS ¹⁾ | idle state |
| Transmit | 01 | 00 SAD5 ... 0 | HS, no HS ¹⁾ | IOM-2, IOM-1, SLD |
| Transmit Broadcast | 01 | 01XXXXXXXX | HS, no HS ¹⁾ | IOM-2, IOM-1, SLD |
| Test Operation | 01 | 10 - - - - - | HS, no HS ¹⁾ | IOM-2, IOM-1, SLD |
| Transmit Continuous | 11 | 00 SAD5 ... 0 | HS ²⁾ | IOM-2 |
| Transmit + Receive Same Time Slot | | | | |
| Any # of Bytes | 10 | 00 SAD5 ... 0 | HS ²⁾ | IOM-2 |
| 1 byte expected | 10 | 00 SAD5 ... 0 | no HS ¹⁾ | IOM-1 |
| 2 bytes expected | 10 | 01 SAD5 ... 0 | no HS ¹⁾ | (IOM-1) |
| 8 bytes expected | 10 | 10 SAD5 ... 0 | no HS ¹⁾ | (IOM-1) |
| 16 bytes expected | 10 | 11 SAD5 ... 0 | no HS ¹⁾ | (IOM-1) |
| Transmit + Receive Same Line | | | | |
| 1 byte expected | 11 | 00 SAD5 ... 0 | no HS ¹⁾ | SLD |
| 2 bytes expected | 11 | 01 SAD5 ... 0 | no HS ¹⁾ | SLD |
| 8 bytes expected | 11 | 10 SAD5 ... 0 | no HS ¹⁾ | SLD |
| 16 bytes expected | 11 | 11 SAD5 ... 0 | no HS ¹⁾ | SLD |

¹⁾ Handshake facility disabled (OMDR:MFPS = 0)

²⁾ Handshake facility enabled (OMDR:MFPS = 1)

Application Hints

Status Register read reset value: 00_H

| | | | | | | | | |
|------|-------|-----|-----|-------------|-------------|-------------|-------------|-------------|
| | bit 7 | | | | | | bit 0 | |
| STAR | MAC | TAC | PSS | MFTO | MFAB | MFAE | MFRW | MFFE |

The status register STAR displays the current state of the MFFIFO and of the monitor transfer operation. It should be interrogated after an ISTA:MFFI interrupt and prior to accessing the MFFIFO.

The STAR register bits do not generate interrupts and are not modified by reading STAR.

- MFTO:** MF Channel Transfer in Operation; an MF channel transfer is in operation (1) or not (0).
- MFAB:** MF Channel Transfer Aborted; a logical 1 indicates that the remote receiver aborted a handshaked message transfer.
- MFAE:** MFFIFO Access Enable; the MFFIFO may be either read or written to (1) or it may not be accessed (0).
- MFRW:** MFFIFO Read/Write; if MFAE is set to logical 1 the MFFIFO may be read (1) or is ready to be written to (0).
- MFFE:** MFFIFO Empty; the MFFIFO is empty (1) or not empty (0).

Interrupt Status Register read reset value: 00_H

| | | | | | | | | |
|------|-------|-----|-------------|------------|-----|-----|-------|-----|
| | bit 7 | | | | | | bit 0 | |
| ISTA | TIN | SFI | MFFI | MAC | PFI | PIM | SIN | SOV |

The ISTA register should be read after an interrupt in order to determine the interrupt source. In connection with the monitor handler two maskable (MASK) interrupt bits are provided by the EPIC:

- MFFI:** MFFIFO interrupt; if this bit is set to 1, the last MF channel command (issued by CMDR:MFT1, MFT0) has been executed and the EPIC is ready to accept the next command. Additional information can be read from STAR:MFTO ... MFFE. MFFI is reset by reading ISTA.
- MAC:** Monitor Channel Active Interrupt; this bit set to 1 indicates that the EPIC has found an active monitor channel. A new search can be started by reissuing the CMDR:MFSO command. MAC is reset by reading ISTA.

5.5.3.2 Description of the MF Channel Commands

Transmit Command

The transmit command can be used for sending MF data to a single subscriber circuit when no answer is expected. It is applicable for both handshake and non handshake protocols. The message (up to 16 bytes) can be written to the MFFIFO after interrogation of the STAR register. After writing of the MF channel address to MFSAR the transfer can be started using the transmit command (CMDR = 04_H). The contents of the MFFIFO will then be transmitted byte by byte to the subscriber circuit.

If the handshake facility is disabled (IOM-1/SLD), the data is sent at a speed of one byte per frame.

If the handshake facility is enabled (IOM-2), each data byte must be acknowledged by the subscriber circuit before the next one is sent. The transfer speed depends therefore on the reaction time of the subscriber circuit. The EPIC can transmit a message at a maximum speed of one byte per two frames.

In order to avoid blocking the software when a subscriber circuit fails to acknowledge a message, a software time out, which resets the monitor transfer (CMDR = 01_H) should be implemented.

If the remote partner aborts the reception of an arriving message i.e. if the EPIC detects an inactive MR bit during at least two consecutive frames, the transmit operation will be stopped, the ISTA:MFFI interrupt will be generated and the STAR:MFAB bit will be set to 1. The CMDR:MFFR bit should then be set to clear the MFAB bit before the next transfer.

When all data bytes of the MFFIFO have been sent (and eventually acknowledged) the EPIC generates an ISTA:MFFI interrupt indicating the end of the transfer. The MF handler may then be pointed to another subscriber address for another monitor transfer.

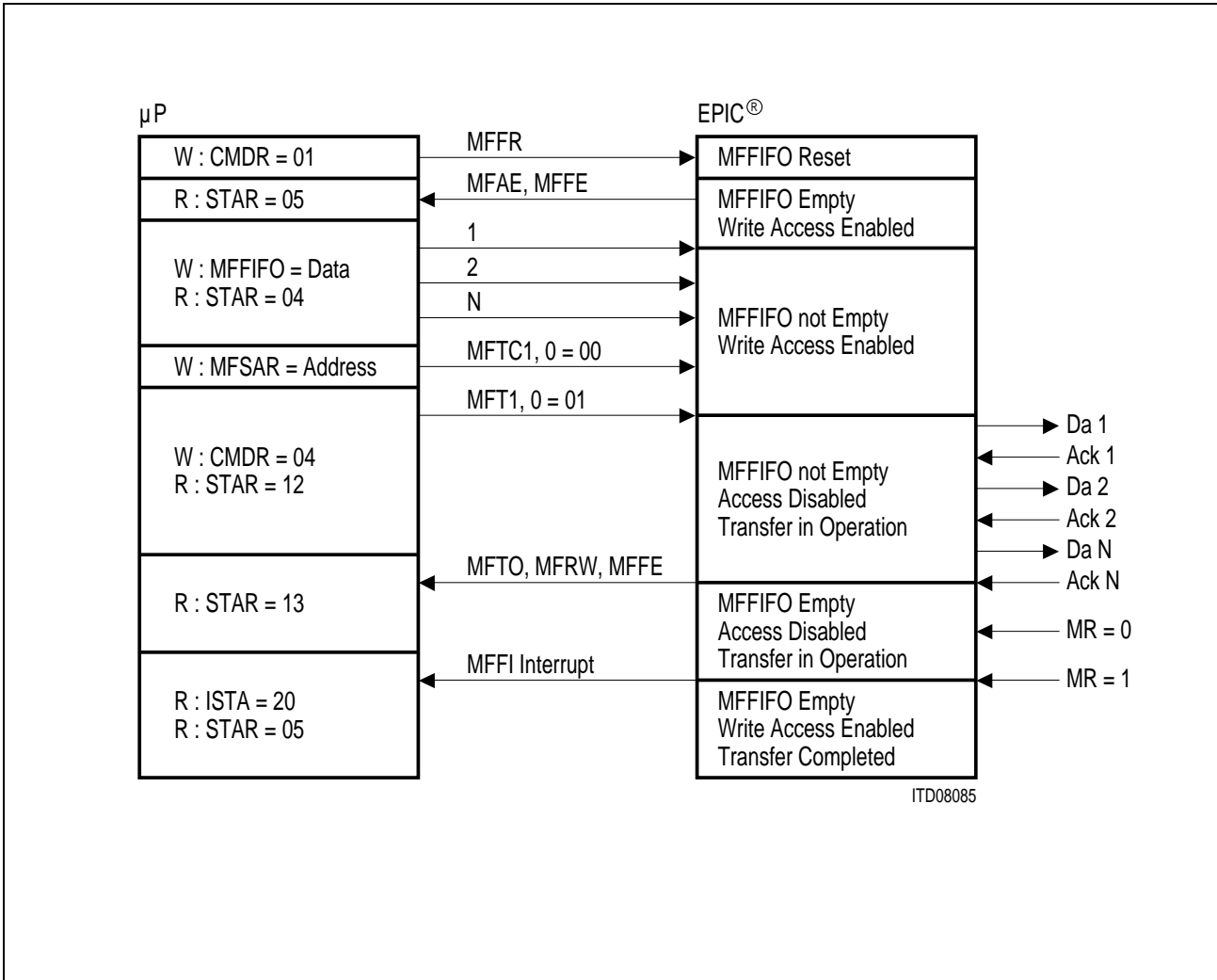

Figure 69
Flow Diagram “Transmit Command”

Transmit Continuous Command

The transmit continuous command can be used in IOM-2 applications only (active handshake protocol) to send monitor messages longer than 16 bytes to a single subscriber circuit.

When this command is given, the EPIC transmits the contents of the MFFIFO as with the normal transmit command but does not conclude the transfer by setting MX inactive when the MFFIFO is empty. Instead, the µP is interrupted (ISTA:MFFI) and requested to write a new block of data into the MFFIFO. This block may then again be transmitted using the transmit continuous command or, if it is the last block of the long message, it may be transmitted using the normal transmit command (CMDR:MFT1, MFT0 = 01). If an answer is expected from the subscriber circuit, the last block may also be terminated using the transmit + receive command (CMDR:MFT1, MFT0 = 10). Each message block may be of arbitrary length (1 to 16 bytes).

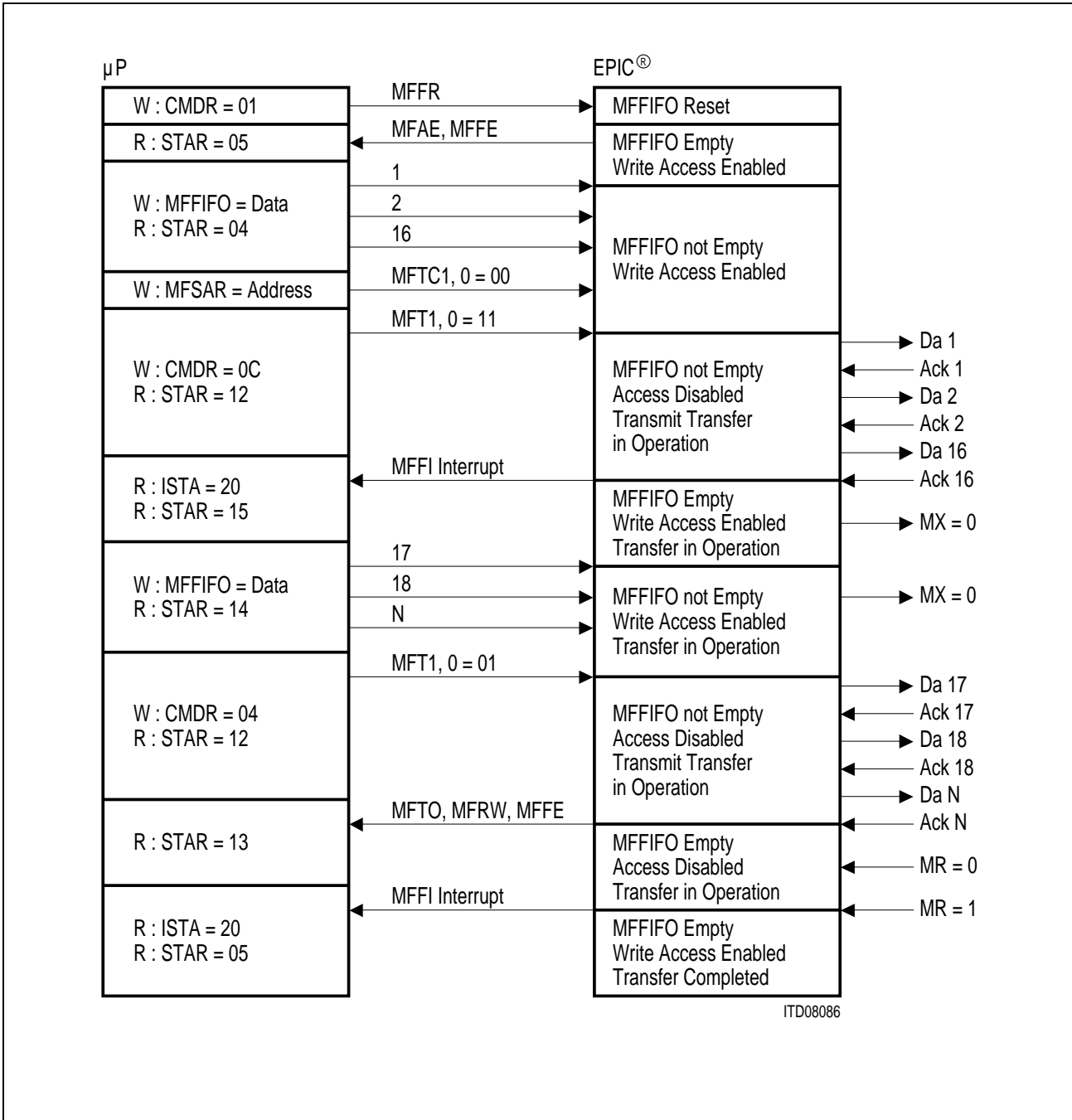

Figure 70
Flow Diagram “Transmit Continuous Command”

Transmit + Receive Same Time Slot Command

The transmit + receive same time slot command can be used to send a message to a subscriber circuit, which will respond with an answer, e.g. reading back the coefficients of a SICOPI device. After first transmitting the contents of the MFFIFO (as with the normal transmit command), the MFFIFO is ready to accept an incoming message which can then be read by the µP when the transfer is completed.

Application Hints

This command can also be used to perform a receive only operation: if a message shall be received without transmission (e.g. after an active monitor channel has been found) the transmit + receive command is issued with an empty MFFIFO.

The command is applicable for both handshake and non-handshake protocols. Since the transfer operation is performed on the same time slot, its use is intended for IOM applications:

– IOM-2, handshake facility enabled:

The contents of the MFFIFO is sent to the subscriber circuit subject to the IOM-2 protocol i.e each byte must be acknowledged before the next one is sent. When the MFFIFO is empty, the EPIC starts to receive the incoming data bytes, each byte being autonomously acknowledged by the EPIC. Up to 16 bytes may be stored in the MFFIFO. When the end of message is detected (MX bit inactive during two consecutive frames), the transfer is considered terminated and an ISTA:MFFI interrupt is generated. The μ P can then fetch the message from the MFFIFO. In order to determine the length of the arrived message, the STAR:MFFE bit (MFFIFO Empty) should be evaluated before each read access to the MFFIFO. After all bytes have been read, the MFFIFO must be reset with the CMDR:MFFR command in order to enable new monitor transfer operations.

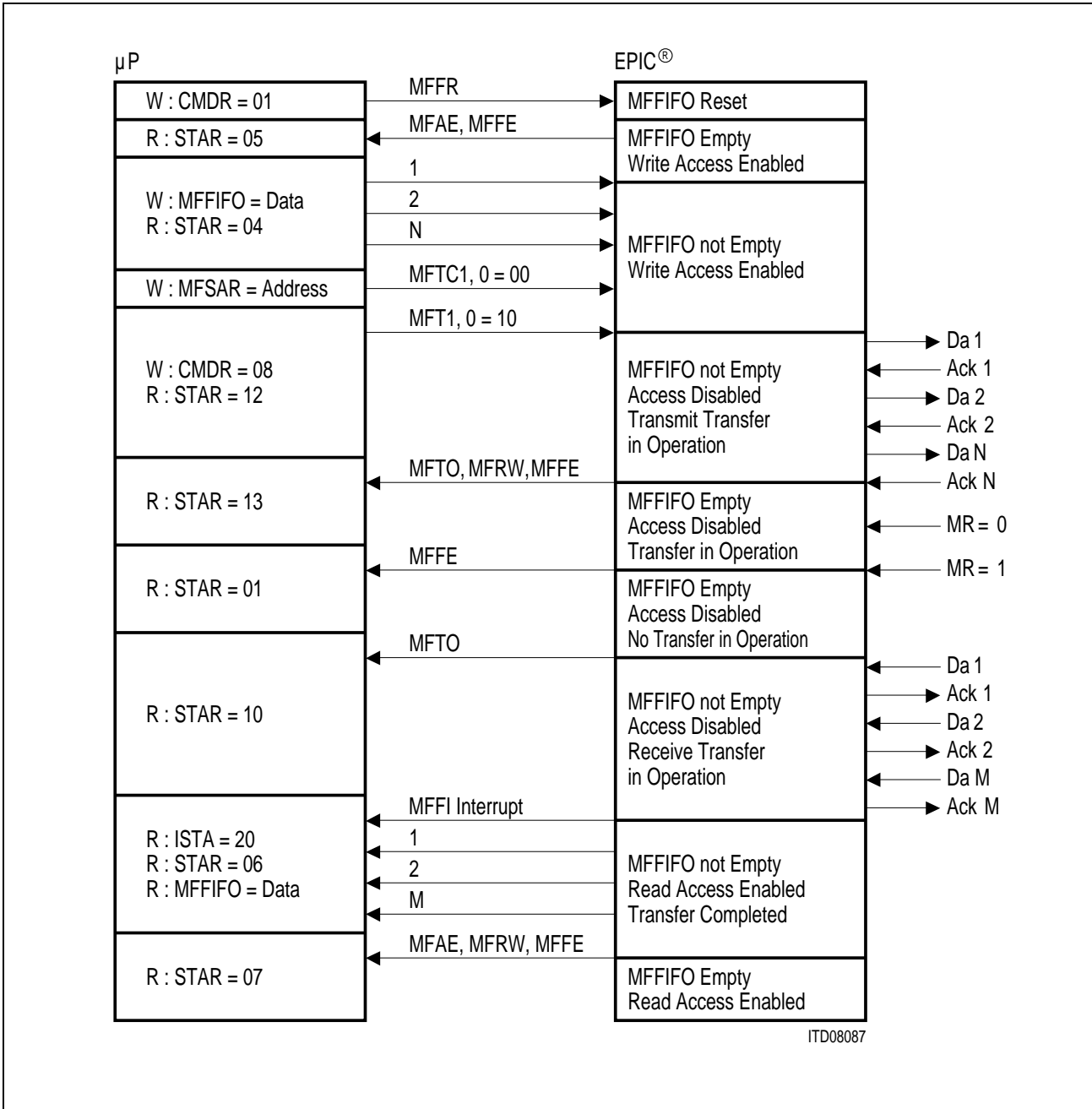

Figure 71
Flow Diagram “Transmit + Receive Same Time Slot Command”

The reception of monitor messages may also (if required) be aborted at any time simply by setting the CMDR:MFFR bit while the receive transfer is still in operation.

If more than 16 bytes shall be received, the following procedure can be adopted:

The first 16 data bytes received will be stored in the MFFIFO and acknowledged to the remote partner. The presence of a 17th byte on the receive line will lead to an ISTA:MFFI interrupt. While the transfer is still in operation (STAR = 16_H), with the 17th byte still left unacknowledged, the µP can read the first 16 bytes out of the MFFIFO. When this is

done (STAR = 17_H), the μ P issues again (with an empty MFFIFO) the transmit + receive command (CMDR = 08_H) and the EPIC is again ready to receive and acknowledge further monitor bytes.

– IOM-1, handshake facility disabled

The contents of the MFFIFO are sent to the subscriber circuit at a speed of 1 byte per frame. When the last byte has been transmitted, the EPIC stores the received monitor bytes of the next subsequent frames into the MFFIFO. The receive transfer is completed and an ISTA:MFFI interrupt is generated after either 1, 2, 8, or 16 frames. The actual number of stored bytes can be selected with MFSAR:MFTC1,MFTC0.

Transmit + Receive Same Line Command

This command is similar to the Transmit + Receive same time slot command i.e. it can be used to send a message to a subscriber circuit which will respond with an answer. Its use is, however, intended for SLD applications: CFI mode 3, 8 time slots/frame, handshake facility disabled.

The transmit operation is performed in the downstream time slot specified in MFSAR while the receive operation is performed on the same SIP line, but four time slots later in the upstream time slot.

Transmit Broadcast Command

The Transmit Broadcast Command can be used for sending a monitor/feature control message to all subscriber circuits simultaneously. It is applicable for both handshake and non handshake protocols. The procedure is similar to the normal transmit command with the exception that the contents of the MFFIFO is transmitted on all downstream MF time slots (defined by the CM code field). If the handshake protocols is active (IOM-2) the data bytes are transmitted at a speed of one byte per three frames and the arriving acknowledgments are ignored.

Test Operation Command

When executing the Test Operation Command, a message written to the MFFIFO will not be transmitted to the subscriber circuit but may instantaneously be read back. All interrupts (ISTA) and status (STAR) bits will be generated in the same manner as for a normal transmit + receive transfers. It is applicable for both handshake and non-handshake protocols.

Search For Active Monitor Channels Command

In IOM-2 applications the monitor channel is sometimes used for low speed data transfers over the S and Q channels of an S interface or over the EOC channel of a U (2B1Q) interface. The layer-1 transceivers (SBCX PEB 2081, IEC-Q PEB 2091) may then, upon reception of a new message, start a monitor channel communication with the EPIC.

For those applications where a slave device initiates an MF channel transfer, the EPIC has implemented the "Search For Active Monitor Channels Command".

The active handshake protocol (OMDR:MFPS = 1) must be selected for this function.

When the "MF Search On" command (CMDR:MFSO = 1) is executed, the EPIC searches for active handshake bits (MX) on all upstream monitor channels. As soon as an active channel is found, an ISTA:MAC interrupt is generated, the search is stopped, and the address of this channel is stored in MFAIR. The μ P can then copy the value of MFAIR to MFSAR in order to point the MF handler to that particular channel. With an empty MFFIFO the transmit + receive same time slot command can be executed to initiate the reception of the monitor message. The EPIC will then autonomously acknowledge each received byte and report the end of the transfer by an ISTA:MFFI interrupt. The μ P can read the message from the MFFIFO and, if required, execute a new MF Search command.

Note: The search should only be started when no receive transfer is in operation, otherwise each received byte will lead to the ISTA:MAC interrupt.

Once started, the search for active monitor channels can only be stopped when such a channel has been found or when the Control Memory is reset or initialized (OMDR:OMS0 = 0).

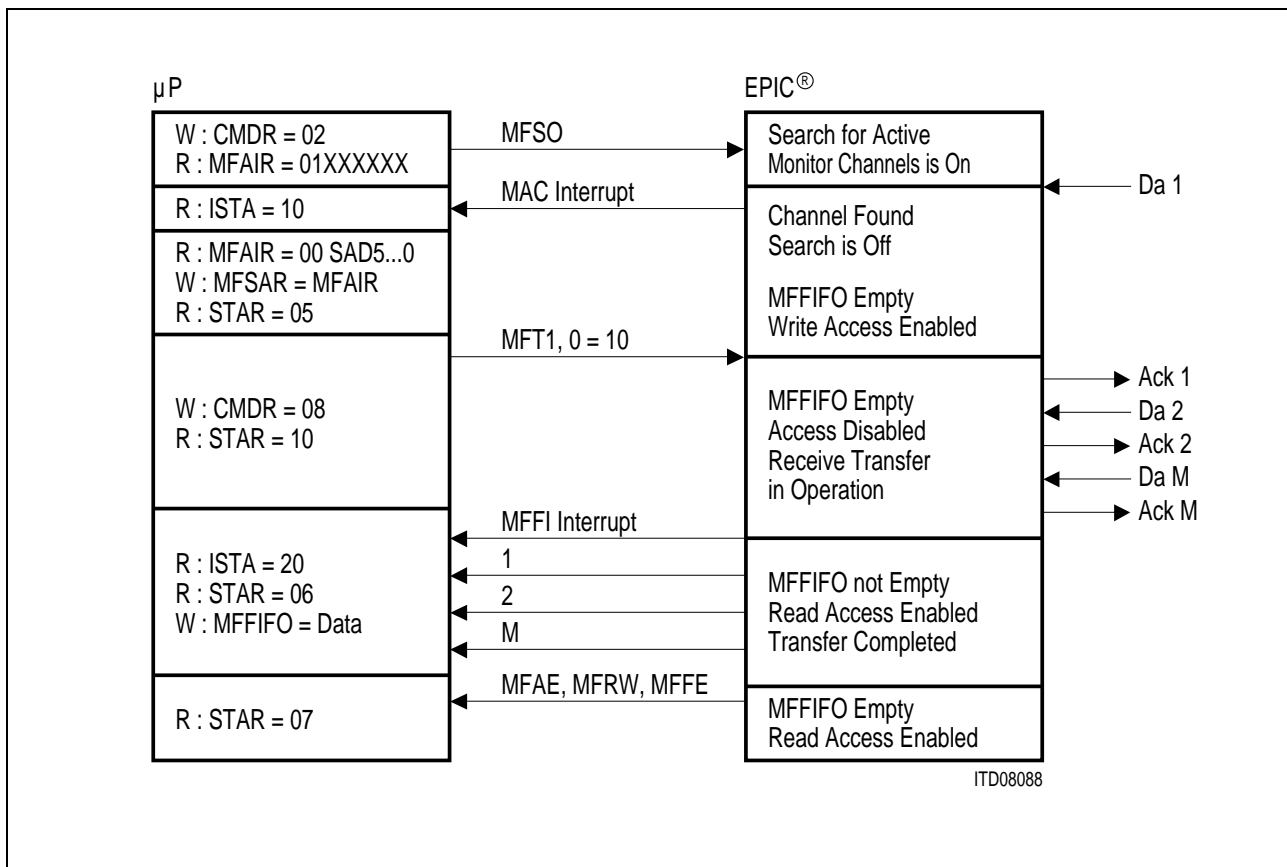
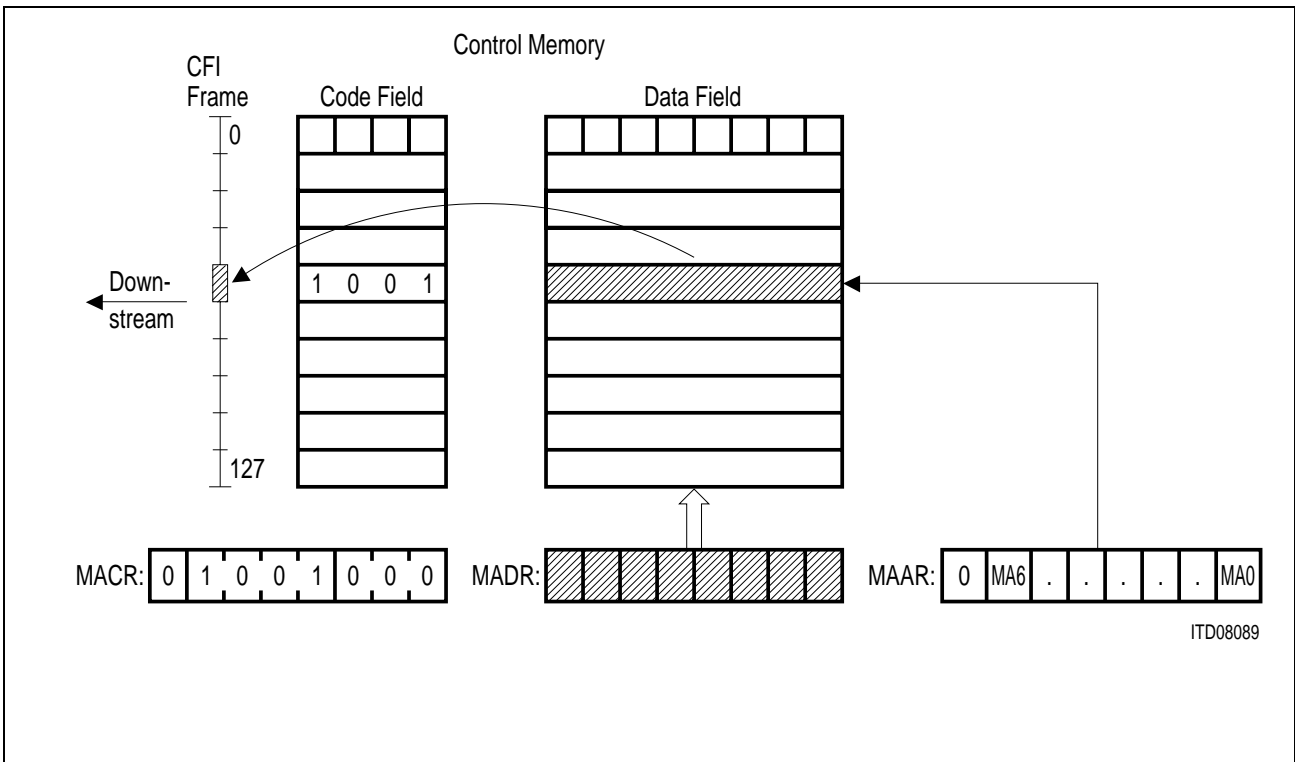

Figure 72
Flow Diagram “Search For Active Monitor Channels Command”

5.6 μ P Channels

If a CFI time slot shall be accessed by the μ P instead of being switched to the PCM interface, this channel can be configured as a μ P channel. This is achieved by writing the code '1001' to the CM code field. In this case the content of the corresponding CFI time slot is directly exchanged with the CM data field. **Figure 73** and **figure 74** illustrate the use of the Control Memory (CM) data and code fields for such applications.

If a CFI time slot is initialized as μ P channel, the function taken on by the CM data field can be compared to the function taken on by the Data Memory (DM) data field at the PCM interface, i.e. it buffers the PCM data received or to be transmitted at the serial interface. In contrast to the PCM interface, where PCM idle channels can be programmed on a 2 bit subtime slot basis, the CFI only allows μ P access for full 8 bit time slots.



ITD08089

Figure 73
 μ P Access to the Downstream CFI Frame

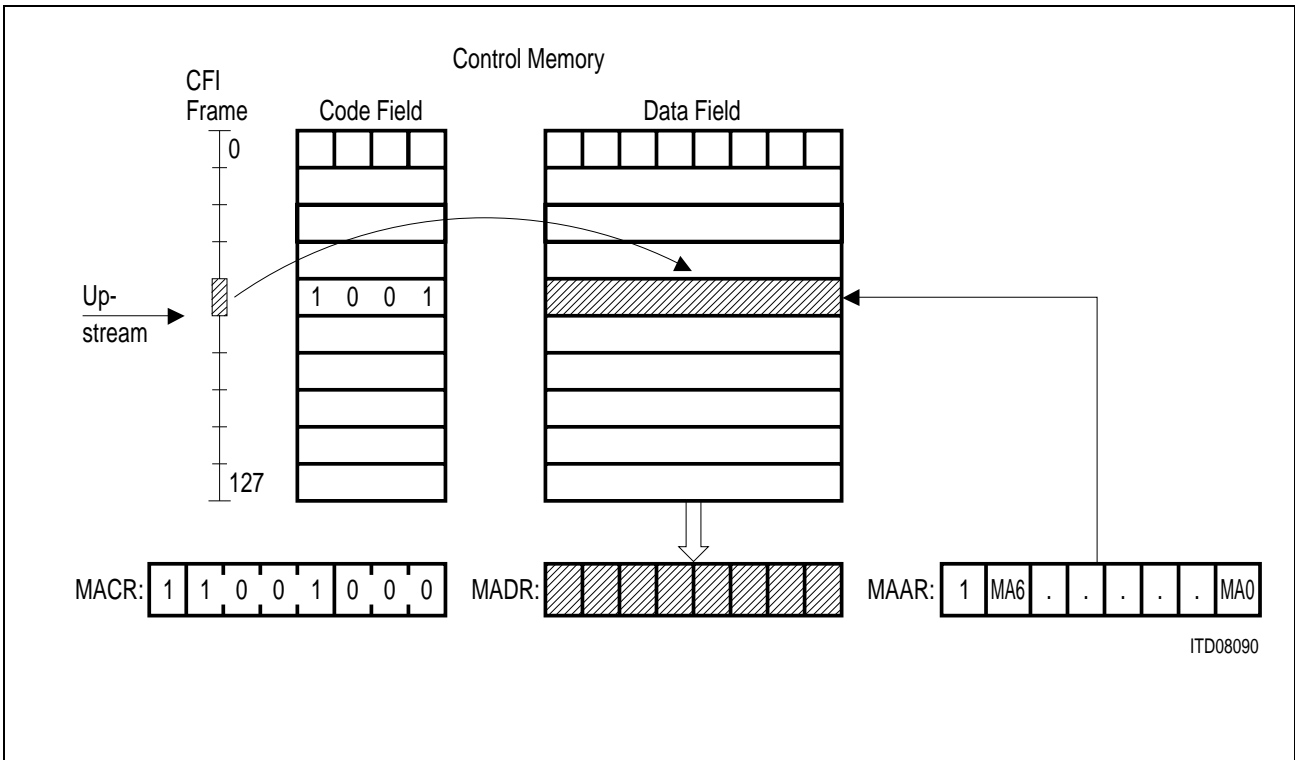

ITD08090

Figure 74
μP Access to the Upstream CFI Frame

The value written to the downstream CM data field location is transmitted repeatedly in every frame (CFI idle value) during the corresponding downstream CFI time slot until a new value is loaded or the 'μP channel' function is disabled. There are no interrupts generated.

The upstream CM data field can be read at any time. The CM data field is updated in every frame. The last value read represents the value received. There are no interrupts generated.

For frame-synchronous exchange of data between the μP and the CFI, the synchronous transfer utility must be used (refer to **chapter 5.7**). Since this utility realizes the data exchange between the STDA (STDB) register and the CM data field, it is also necessary to initialize the corresponding CFI time slots as μP channels.

The following sequences can be used to program, verify, and cancel a CFI μP channel:

Writing a Downstream CFI Idle Value

- in case the CM code field has not yet been initialized with the ‘ μ P channel’ code:

W:MADR = CFI idle value to be transmitted
 W:MAAR = downstream CFI port and time slot encoded according to **figure 48**
 W:MACR = 0111 1001_B = 79_H; CM code ‘1001’ (μ P transfer)

- in case the CM code field has already been initialized with the ‘ μ P channel’ code:

W:MADR = CFI idle value to be transmitted
 W:MAAR = downstream CFI port and time slot encoded according to **figure 48**
 W:MACR = 0100 1000_B = 48_H; MOC code ‘1001’ (CM data field access)

Reading an Upstream CFI idle Value

- Initializing an upstream CFI time slot as a μ P channel:

W:MADR = don't care
 W:MAAR = upstream CFI port and time slot encoded according to **figure 48**
 W:MACR = 0111 1001_B = 79_H; CM code ‘1001’ (μ P transfer)

- Reading the upstream CFI idle value:

W:MAAR = upstream CFI port and time slot encoded according to **figure 48**
 W:MACR = 1100 1000_B = C8_H; MOC code ‘1001’ (CM data field access)
 wait for STAR:MAC = 0
 R:MADR = received CFI idle value

Reading Back the Idle Value Transmitted at a Downstream CFI μ P Channel:

W:MAAR = downstream CFI port and time slot encoded according to **figure 48**
 W:MACR = 1100 1000_B = C8_H; MOC code ‘1001’ (CM data field access)
 wait for STAR:MAC = 0
 R:MADR = transmitted CFI idle value

Reading Back the CFI Functionality of a given CFI Time Slot:

W:MAAR = CFI port and time slot encoded according to **figure 48**
 W:MACR = 1111 0000_B = F0_H; MOC code ‘111X’ (CM code field access)
 wait for STAR:MAC = 0
 R:MADR = XXXX code_B; if code = 1001, the CFI time slot is a ‘ μ P channel’

Cancelling of a Programmed CFI μ P Channel:

W:MADR = don't care
 W:MAAR = CFI port and time slot encoded according to **figure 48**
 W:MACR = 0111 0000_B = 70_H; code ‘0000’ (unassigned channel)

Examples

In CFI mode 1 the following μ P channels shall be realized:

Upstream: CFI port 1, time slot 7:

W:MADR = 1111 1111_B ; don't care
 W:MAAR = 1000 1111_B ; CFI time slot encoding according to **figure 48**
 W:MACR = 0111 1001_B ; CM code for a μ P channel (code '1001')

Downstream: CFI port 0, time slot 2, the value '0000 0111' shall be transmitted:

W:MADR = 0000 0111_B ; CFI idle value '0000 0111'
 W:MAAR = 0000 0100_B ; CFI time slot encoding according to **figure 48**
 W:MACR = 0111 1001_B ; CM code for a μ P channel (code '1001')

The next sequence will read the currently received value at DU1, TS7:

W:MAAR = 1000 1111_B ; upstream CFI port and time slot
 W:MACR = 1100 1000_B = C8_H; read back command
 wait for STAR:MAC = 0
 R:MADR = value ; received CFI idle value

5.7 Synchronous Transfer Utility

The synchronous transfer utility allows the synchronous exchange of information between the PCM interface, the configurable interface, and the μ P interface for two independent channels (A and B). The μ P can thus monitor, insert, or manipulate the data synchronously to the frame repetition rate. The synchronous transfer is controlled by the synchronous transfer registers.

The information is buffered in the synchronous transfer data register STDA (STDB). It is copied to STDA (STDB) from a data or control memory location pointed to by the content of the synchronous receive register SARA (SARB) and copied from the STDA (STDB) to a data or control memory location pointed to by the content of the synchronous transfer transmit register SAXA (SAXB).

The SAXA (SAXB) and SARA (SARB) registers identify the interface (PCM or CFI) as well as the time slot and port numbers of the involved channels according to **figure 48**. Control bits in the synchronous transfer control register STCR allow restricting the synchronous transfer to one of the possible subtime slots and enables or disables the synchronous transfer utility.

For example, it is possible to read information via the downstream data memory from the PCM interface input to the STDA (STDB) register and to transmit it from this register back via the upstream data memory to the PCM interface output, thus establishing a PCM - PCM loop. Similarly the synchronous transfer facility may be used to loop back configurable interface channels or to establish connections between the CFI and PCM interfaces. While the information is stored in the data register STDA (STDB), it may be read and or modified by the μ P.

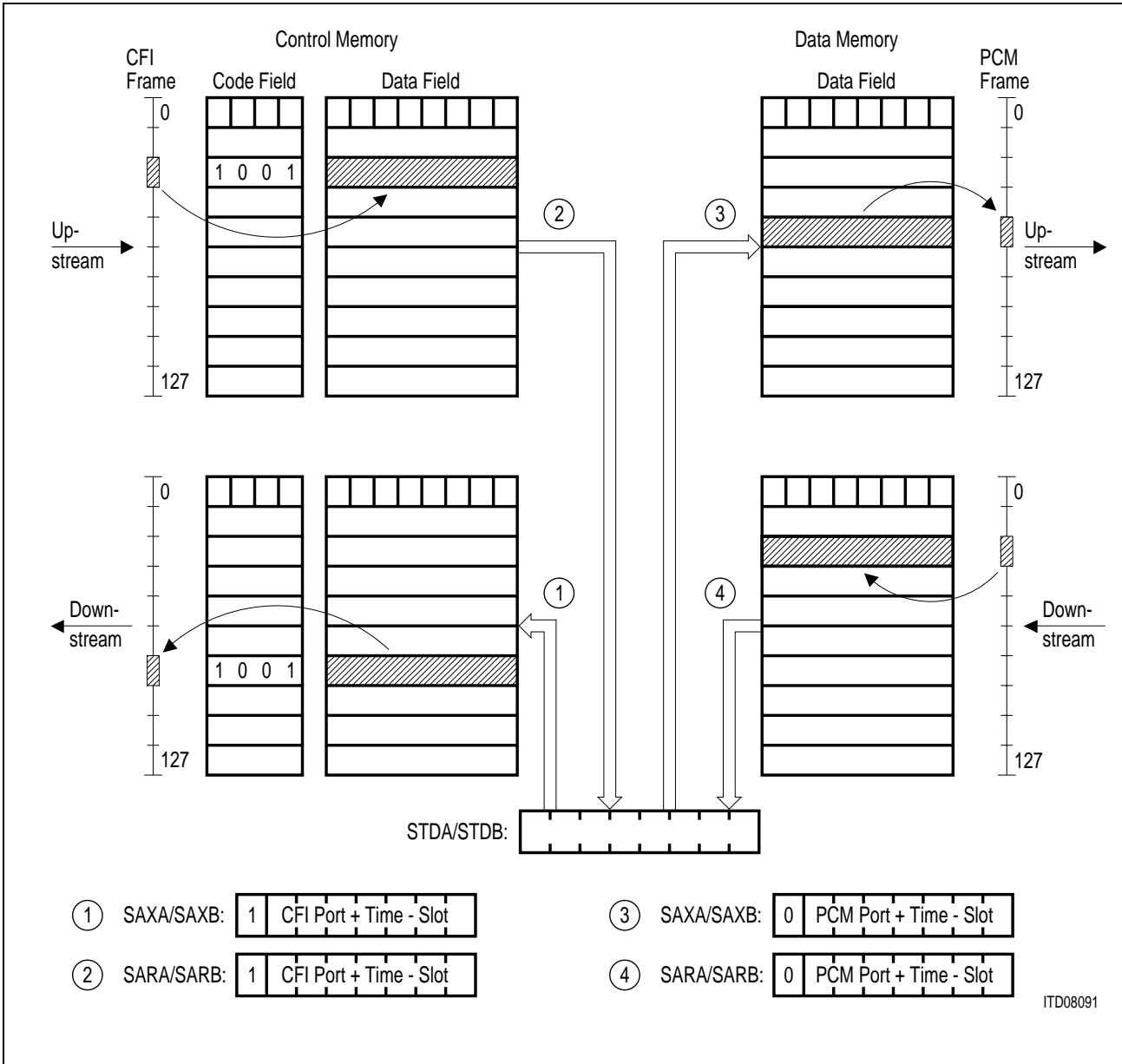

Figure 75
Access to PCM and CFI Data Using the Synchronous Transfer Utility

In upstream transmit direction (PCM interface output), it is necessary to assure that no other data memory access writes to the same location in the upstream DM block. Hence an upstream connection involving the same PCM port and time slot as the synchronous transfer may not be programmed.

An idle code previously written to the data or control memory for the upstream or downstream directions is overwritten.

At the PCM interface it is possible to restrict the synchronous exchange with the data registers STDA (STDB) to a 2 or 4 bit subtime slot position. The working principle is similar to the subchannel switching described in **chapter 5.4.2**.

If the CFI is selected as source/destination of the synchronous transfer, the contents of the data register STDA (STDB) are exchanged with the control memory data field. It is therefore necessary to initialize the corresponding control memory code field as 'µP channel' (code '1001'). Also refer to **chapter 5.6**.

Since the µP channel set-up at the CFI only allows a channel bandwidth of 64 kbit/s, the synchronous transfer utility also allows only 64 kbit/s channels at the CFI.

The EPIC generates interrupts guiding through the synchronous transfer. Upon the ISTA:SIN interrupt the data registers STDA (STDB) may be accessed for some time. If the data register of an active channel has not been accessed at the end of this time interval the ISTA:SOV interrupt is generated, before the EPIC performs the transfer to the selected memory locations. If the µP fails to overwrite the data register with a new value, the value previously received from the time slot pointed to by SARA (SARB) will be transmitted. The ISTA:SIN and SOV interrupts are generated periodically at fixed time points within the frame regardless of the actual positions of the involved time slots. The repetition cycle of the synchronous transfer is identical to a frame length (125 µs). The access window is closed for at most, 16 RCL periods per active channel + 1 RCL period, leaving a very long access time.

This behavior is also shown in **figure 76**:

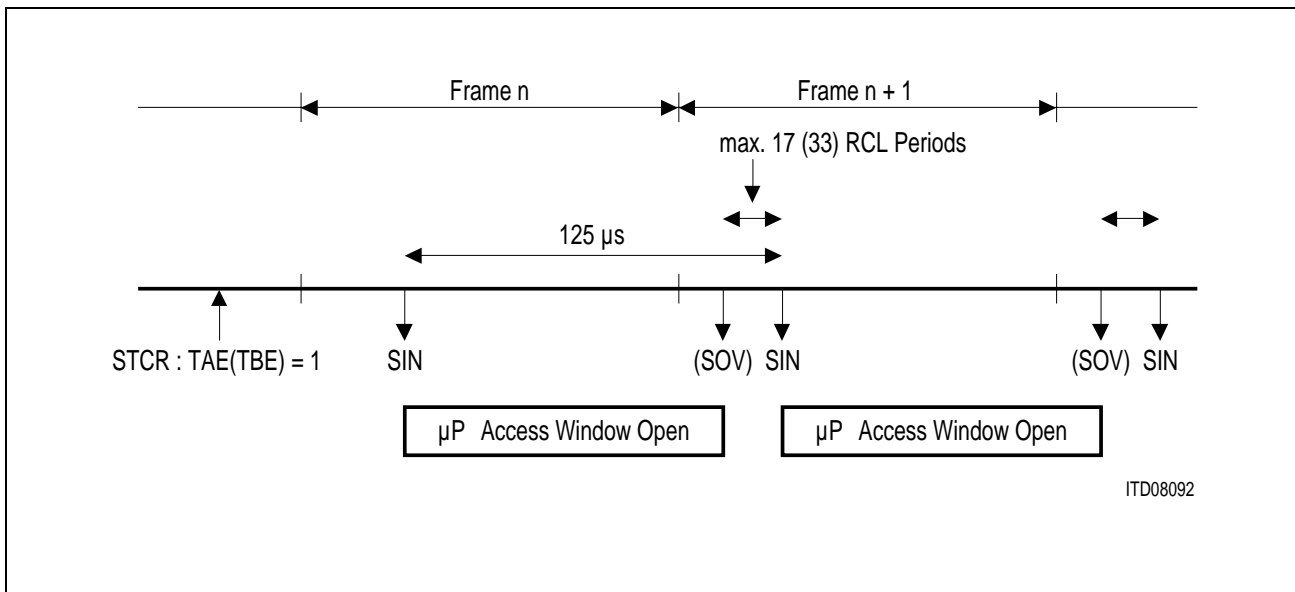

Figure 76
Synchronous Transfer Flow Diagram

Example

In a typical IOM-2 application, the RCL frequency is 4.096 MHz, i.e. an RCL period lasts 244 ns. The IOM-2 frame duration is 125 µs. If one synchronous channel is enabled, the access window is open for 121 µs and closed for 4 µs. If both synchronous channels are enabled, the access window is open for 117 µs and closed for 8 µs.

5.7.1 Registers Used in Conjunction with the Synchronous Transfer Utility

Synchronous Transfer Data

Register A read/write reset value: undefined

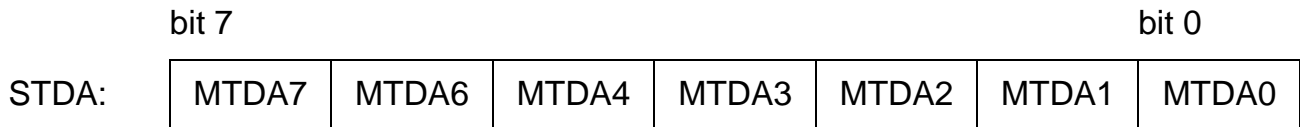

The STDA register buffers the data transferred over the synchronous transfer channel A. MTDA7 to MTDA0 hold the bits 7 to 0 of the respective time slot. MTDA7 (MSB) is the bit transmitted/received first, and MTDA0 (LSB) the bit transmitted/received last over the serial interface.

Synchronous Transfer Data

Register B read/write reset value: undefined

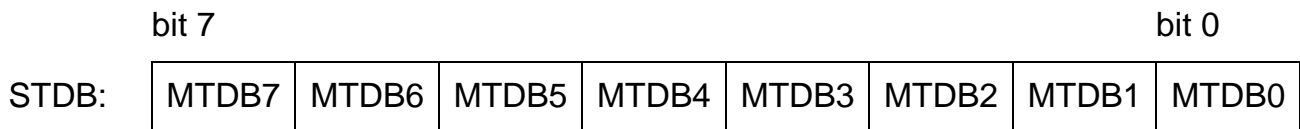

The STDB register buffers the data transferred over the synchronous transfer channel B. MTDB7 to MTDB0 hold the bits 7 to 0 of the respective time slot. MTDB7 (MSB) is the bit transmitted/received first, MTDB0 (LSB) the bit transmitted/received last over the serial interface.

Synchronous Transfer Receive

Address Register A read/write reset value: undefined

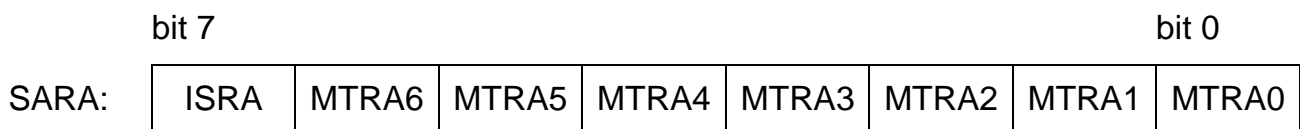

The SARA register specifies for synchronous transfer channel A from which input interface, port, and time slot the serial data is extracted. This data can then be read from the STDA register.

ISRA: Interface Select Receive for channel A; selects the PCM interface (ISRA = 0) or the CFI (ISRA = 1) as the input interface for synchronous channel A.

Application Hints

MTRA6 ... 0: μ P Transfer Receive Address for channel A; selects the port and time slot number at the interface selected by ISRA according to **figure 48**:
MTRA6 ... 0 = MA6 ... 0.

Synchronous Transfer Receive

Address Register B

read/write reset value: undefined

| | | | | | | | | |
|-------|-------|-------|-------|-------|-------|-------|-------|-------|
| | bit 7 | | | | | | | bit 0 |
| SARB: | ISRB | MTRB6 | MTRB5 | MTRB4 | MTRB3 | MTRB2 | MTRB1 | MTRB0 |

The SARB register specifies for synchronous transfer channel B from which input interface, port, and time slot the serial data is extracted. This data can then be read from the STDB register.

ISRB: Interface Select Receive for channel B; selects the PCM interface (ISRB = 0) or the CFI (ISRB = 1) as the input interface for synchronous channel B.

MTRB6 ... 0: μ P Transfer Receive Address for channel B; selects the port and time slot number at the interface selected by ISRB according to **figure 48**:
MTRB6 ... 0 = MA6 ... 0.

Synchronous Transfer Transmit

Address Register A

read/write reset value: undefined

| | | | | | | | | |
|-------|-------|-------|-------|-------|-------|-------|-------|-------|
| | bit 7 | | | | | | | bit 0 |
| SAXA: | ISXA | MTXA6 | MTXA5 | MTXA4 | MTXA3 | MTXA2 | MTXA1 | MTXA0 |

The SAXA register specifies for synchronous transfer channel A to which output interface, port, and time slot the serial data contained in the STDA register is sent.

ISXA: Interface Select Transmit for channel A; selects the PCM interface (ISXA = 0) or the CFI (ISXA = 1) as the output interface for synchronous channel A.

MTXA6 ... 0: μ P Transfer Transmit Address for channel A; selects the port and time slot number at the interface selected by ISXA according to **figure 48**:
MTXA6 ... 0 = MA6 ... 0.

**Synchronous Transfer Transmit
Address Register B**

read/write reset value: undefined

| | | | | | | | | |
|-------|-------|-------|-------|-------|-------|-------|-------|-------|
| | bit 7 | | | | | | | bit 0 |
| SAXB: | ISXB | MTXB6 | MTXB5 | MTXB4 | MTXB3 | MTXB2 | MTXB1 | MTXB0 |

The SAXB register specifies for synchronous transfer channel B to which output interface, port, and time slot the serial data contained in the STDB register is sent.

ISXB: Interface Select Transmit for channel B; selects the PCM interface (ISXB = 0) or the CFI (ISXB = 1) as the output interface for synchronous channel B.

MTXB6 ... 0: μ P Transfer Transmit Address for channel B; selects the port and time slot number at the interface selected by ISXB according to **figure 48**: MTXB6 ... 0 = MA6 ... 0.

**Synchronous Transfer Control
Register STCR**

read/write reset value: undefined

| | | | | | | | | |
|-------|-------|-----|------|------|------|------|------|-------|
| | bit 7 | | | | | | | bit 0 |
| STCR: | TBE | TAE | CTB2 | CTB1 | CTB0 | CTA2 | CTA1 | CTA0 |

The STCR register bits are used to enable or disable the synchronous transfer utility and to determine the subtime slot bandwidth and position if a PCM interface time slot is involved.

TAE, TBE: Transfer Channel A (B) Enable; A logical 1 enables the μ P transfer, a logical 0 disables the transfer of the corresponding channel.

CTA2 ... 0: Channel Type A (B); these bits determine the bandwidth of the channel and the position of the relevant bits in the time slot according

to **table 33**. Note that if a CFI time slot is selected as receive or transmit time slot of the synchronous transfer, the 64 kbit/s bandwidth must be selected (CT#2 ... CT#0 = 001).

Table 33

| CT#2 | CT#1 | CT#0 | Bandwidth | Transferred Bits |
|------|------|------|-------------|------------------|
| 0 | 0 | 0 | not allowed | – |
| 0 | 0 | 1 | 64 kbit/s | bits 7 ... 0 |
| 0 | 1 | 0 | 32 kbit/s | bits 3 ... 0 |
| 0 | 1 | 1 | 32 kbit/s | bits 7 ... 4 |
| 1 | 0 | 0 | 16 kbit/s | bits 1 ... 0 |
| 1 | 0 | 1 | 16 kbit/s | bits 3 ... 2 |
| 1 | 1 | 0 | 16 kbit/s | bits 5 ... 4 |
| 1 | 1 | 1 | 16 kbit/s | bits 7 ... 6 |

Interrupt Status Register read/write reset value: 00_H

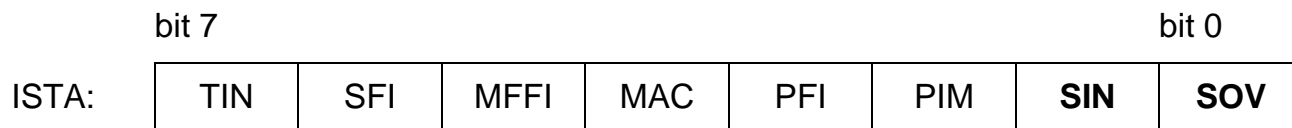

The ISTA register should be read after an interrupt in order to determine the interrupt source. Two maskable (MASK) interrupts are provided in connection with the synchronous transfer utility:

- SIN:** Synchronous Transfer Interrupt; The SIN interrupt is enabled if at least one synchronous transfer channel (A and/or B) is enabled via the STCR:TAE, TBE bits. The SIN interrupt is generated when the access window for the μ P opens. After the occurrence of the SIN interrupt (logical 1) the μ P can read and/or write the synchronous transfer data registers (STDA, STDB). The window where the μ P can access the data registers is open for the duration of one frame (125 μ s) minus 17 RCL cycles if only one synchronous channel is enabled and it is open for one frame minus 33 RCL cycles if both A and B channels are enabled. The SIN bit is reset by reading ISTA.
- SOV:** Synchronous Transfer Overflow; The SOV interrupt is generated (logical 1) if the μ P fails to access the data registers (STDA, STDB) within the access window. The SOV bit is reset by reading ISTA.

Examples

- 1) In PCM mode 0, the synchronous transfer utility (channel A) shall be used to loop bits 7 ... 6 of downstream PCM port 1, time slot 5 back to bits 7 ... 6 of upstream PCM port 2, time slot 9. Since no μ P access to the data is required the ISTA:SIN and SOV bits are both masked:

```

W:MASK    = 03H    ; SIN = SOV = 1
W:SARA    = 13H    ; ISRA = 0, port 1, TS5
W:SAXA    = 25H    ; ISXA = 0, port 2, TS9
W:STCR    = 47H    ; TAE = 1, CTA2 ... 0 = 111 (bits 7 ... 6)
    
```

- 2) In PCM mode 0 and CFI mode 0, the μ P shall have access to both the downstream and upstream CFI port 0, time slot 1 via the synchronous transfer channel B:

```

W:SARB    = 81H    ; ISRB = 1, port 0, TS1
W:SAXB    = 81H    ; ISXB = 1, port 0, TS1
W:STCR    = 88H    ; TBE = 1, CTA2 ... 0 = 001 (bits 7 ... 0)
    
```

Wait for interrupt:

```

R:ISTA    = 02H    ; SIN = 1
R:STDB    = upstream CFI data
W:STDB    = downstream CFI data
    
```

Wait for next SIN interrupt and transfer further data bytes

5.8 Supervision Functions

5.8.1 Hardware Timer

Hardware Timer

The EPIC provides a programmable hardware timer which can be used for three purposes:

- General purpose timer for continuously interrupting the μ P at programmable time intervals.
- Timer to define the last look period for signaling channels at the CFI (see **chapter 5.5.1**).
- Timer to define the FSC multiframe generation at the CFI (CMD2:FC2 ... 0 = 111, see **chapter 5.2.2.3**).

Normally in a system only one of these functions is required and therefore active at a time. However, it is also possible to have any combination of these functions active, if it is acceptable that all three applications use the same timer value.

The timer period can be selected from 250 μ s up to 32 ms in increments of 250 μ s.

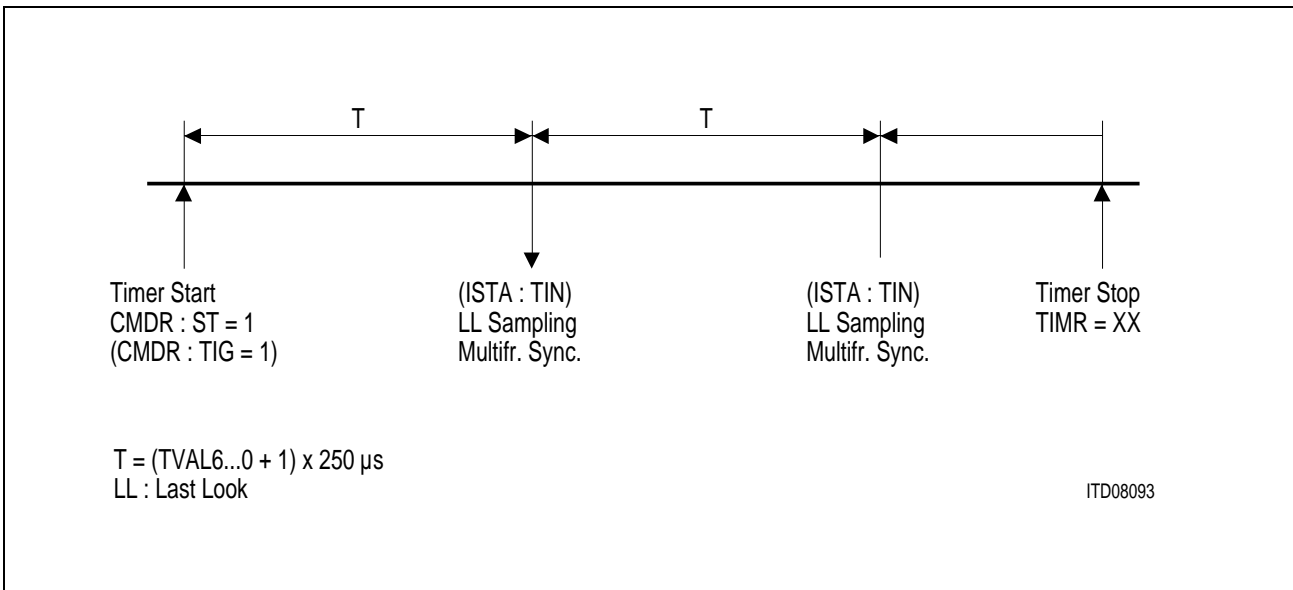

Figure 77
Timer Applications

Application Hints

The following register bits are used in conjunction with the hardware timer:

Timer Register write reset value: 00_H

| | | | | | | | | |
|-------|-------|-------|-------|-------|-------|-------|-------|-------|
| | bit 7 | | | | | | | bit 0 |
| TIMR: | SSR | TVAL6 | TVAL5 | TVAL4 | TVAL3 | TVAL2 | TVAL1 | TVAL0 |

Writing to the TIMR register stops the timer operation!

SSR: Signaling Channel Sample Rate; this bit actually does not affect the timer operation. It is used to select between a fixed last look period for signaling channels of 125 μs (SSR = 1), which is independent of the timer operation and a signaling sample rate that is defined by the timer period (SSR = 0).

TVAL6 ... 0: Timer Value; The timer period is programmed here in increments of 250 μs:
 Timer period = (TVAL6 ... 0 + 1) × 250 μs

Command Register write reset value: 00_H

| | | | | | | | | |
|------|-------|-----------|------------|-----|------|------|------|-------|
| | bit 7 | | | | | | | bit 0 |
| CMDR | 0 | ST | TIG | CFR | MFT1 | MFT0 | MFSO | MFR |

ST: Start Timer; setting this bit to logical 1 starts the timer to run cyclically from 0 to the value programmed in TIMR:TVAL6 ... 0. Setting this bit to logical 0 does not affect the timer operation. If the timer shall be stopped, the TIMR register must simply be written with a random value.

TIG: Timer Interrupt Generation; setting this bit together with CMDR:ST to logical 1 causes the EPIC to generate a periodic interrupt (ISTA:TIN) each time the timer expires. Setting the TIG bit to logical 0 together with the CMDR:ST bit set to logical 1 disables the interrupt generation. It should be noted that this bit only controls the ISTA:TIN interrupt generation and need not be set for the ISTA:SFI interrupt generation.

Application Hints

Interrupt Status Register

read/write reset value: 00_H

| | | | | | | | | |
|-------|------------|-----|------|-----|-----|-----|-----|-------|
| | bit 7 | | | | | | | bit 0 |
| ISTA: | TIN | SFI | MFFI | MAC | PFI | PIM | SIN | SOV |

The ISTA register should be read after an interrupt in order to determine the interrupt source. In connection with the hardware timer one maskable (MASK) interrupt bit is provided by the EPIC:

TIN: Timer Interrupt; if this bit is set to logical 1, a timer interrupt previously requested with `CMDR:ST,TIG = 1` has occurred. The TIN bit is reset by reading ISTA. It should be noted that the interrupt generation is periodic, i.e. unless stopped by writing to `TIMR`, the `ISTA:TIN` will be generated each time the timer expires.

Status Register

read reset value: 05_H

| | | | | | | | | |
|-------|-------|------------|-----|------|------|------|------|-------|
| | bit 7 | | | | | | | bit 0 |
| STAR: | MAC | TAC | PSS | MFTO | MFAB | MFAE | MFRW | MFFE |

The STAR register bits do not generate interrupts and are not modified by reading STAR.

TAC: Timer Active; While the timer is running (`CMDR:ST=1`) the TAC bit is set to logical 1. The TAC bit is reset to logical 0 after the timer has been stopped (`W:TIMR = XX`).

5.8.2 PCM Input Comparison

To simplify the realization of redundant PCM transmission lines, the EPIC can be programmed to compare the contents of certain pairs of its PCM input lines. If a pair of lines carry the same information (normal case), nothing happens. If however the two lines differ in at least one bit (error case), the EPIC generates an `ISTA:PIM` interrupt and indicates in the `PICM` register the pair of input lines and the time slot number that caused that mismatch.

The comparison function is carried out between the pairs of physical PCM input lines `RxD0/RxD1` and `RxD2/RxD3`. It can be activated in all PCM modes, including PCM mode 0. However, a redundant PCM input line that can be switched over to by means of the `PMOD: AIS1 ... 0` bits is of course only available in PCM modes 1 and 2.

Application Hints

The following register bits are used in conjunction with the PCM input comparison function:

PCM Mode Register read/write reset value: 00_H

| | | | | | | | | |
|-------|-------|------|-----|-----|------|------|-------------|-------------|
| | bit 7 | | | | | | bit 0 | |
| PMOD: | PMD1 | PMD0 | PCR | PSM | AIS1 | AIS0 | AIC1 | AIC0 |

AIC1 ... 0: Alternative Input Comparison 1 and 0.
 AIC0 set to logical 1 enables the comparison function between RxD0 and RxD1.
 AIC1 set to logical 1 enables the comparison function between RxD2 and RxD3.
 AIC1, AIC0 set to logical 0 disables the respective comparison function.
 In PCM mode 2, AIC0 must be set to logical 0.

Interrupt Status Register read reset value: 00_H

| | | | | | | | |
|-------|-------|-----|------|-----|-----|------------|-------|
| | bit 7 | | | | | | bit 0 |
| ISTA: | TIN | SFI | MFFI | MAC | PFI | PIM | SOV |

The ISTA register should be read after an interrupt in order to determine the interrupt source. In connection with the PCM comparison function one maskable (MASK) interrupt bit is provided by the EPIC:

PIM: PCM Input Mismatch; this bit is set to logical 1 immediately after the comparison logic has detected a mismatch between a pair of PCM input lines. The exact reason for the interrupt can be determined by reading the PICM register. Reading ISTA clears the PIM bit. A new PIM interrupt can only be generated after the PICM register has been read.

Application Hints

PCM Input Comparison Mismatch read reset value: undefined

bit 7 bit 0

| | | | | | | | | |
|-------|-----|------|------|------|------|------|------|------|
| PICM: | IPN | TSN6 | TSN5 | TSN4 | TSN3 | TSN2 | TSN1 | TSN0 |
|-------|-----|------|------|------|------|------|------|------|

The contents of the PICM register is only valid after an ISTA:PIM interrupt!

The PICM register must be read after an ISTA:PIM interrupt in order to enable a new PIM interrupt generation.

IPN: Input Pair Number; this bit indicates the pair of input lines where a mismatch occurred. A logical 0 indicates a mismatch between lines RxD0 and RxD1, a logical 1 between lines RxD2 and RxD3.

TSN6 ... 0: Time slot Number 6 ... 0; these bits specify the time slot number and the bit positions that generated the ISTA:PIM interrupt according to the table below. TPF denotes the number of time slots per PCM frame

Table 34

| PCM Mode | Time Slot Identification | Bit Identification |
|----------|---------------------------------------|--|
| 2 | $[TSN6 \dots 0 + 8]_{\text{mod TPF}}$ | |
| 1 | $[TSN6 \dots 1 + 4]_{\text{mod TPF}}$ | TSN0 = 1 : bits 3 ... 0 TSN0 = 0 : bits 7 ... 4 |
| 0 | $[TSN6 \dots 2 + 2]_{\text{mod TPF}}$ | TSN1 ... 0 = 11 : bits 1 ... 0 TSN1 ... 0 = 10 : bits 3 ... 2 TSN1 ... 0 = 01 : bits 5 ... 4 TSN1 ... 0 = 00 : bits 7 ... 6 |

Example

In PCM mode 1, the logical PCM port 0 is connected to two physical PCM transmission links. The comparison function for RxD0/RxD1 is enabled via PMOD:AIC0 = 1. Suddenly a bit error occurs at one of the receive lines in time slot 13, bit 2. The µP would then get the following information from the EPIC:

Interrupt!

R: ISTA = 04_H ; PIM interrupt
R: PICM = 13_H ; IPN = 0, TSN6 ... 1 = 9, TSN0 = 1

In order to determine the line actually at fault (RxD0 or RxD1) the system must send a known pattern in one of the time slots and compare the actually received value with that known pattern.

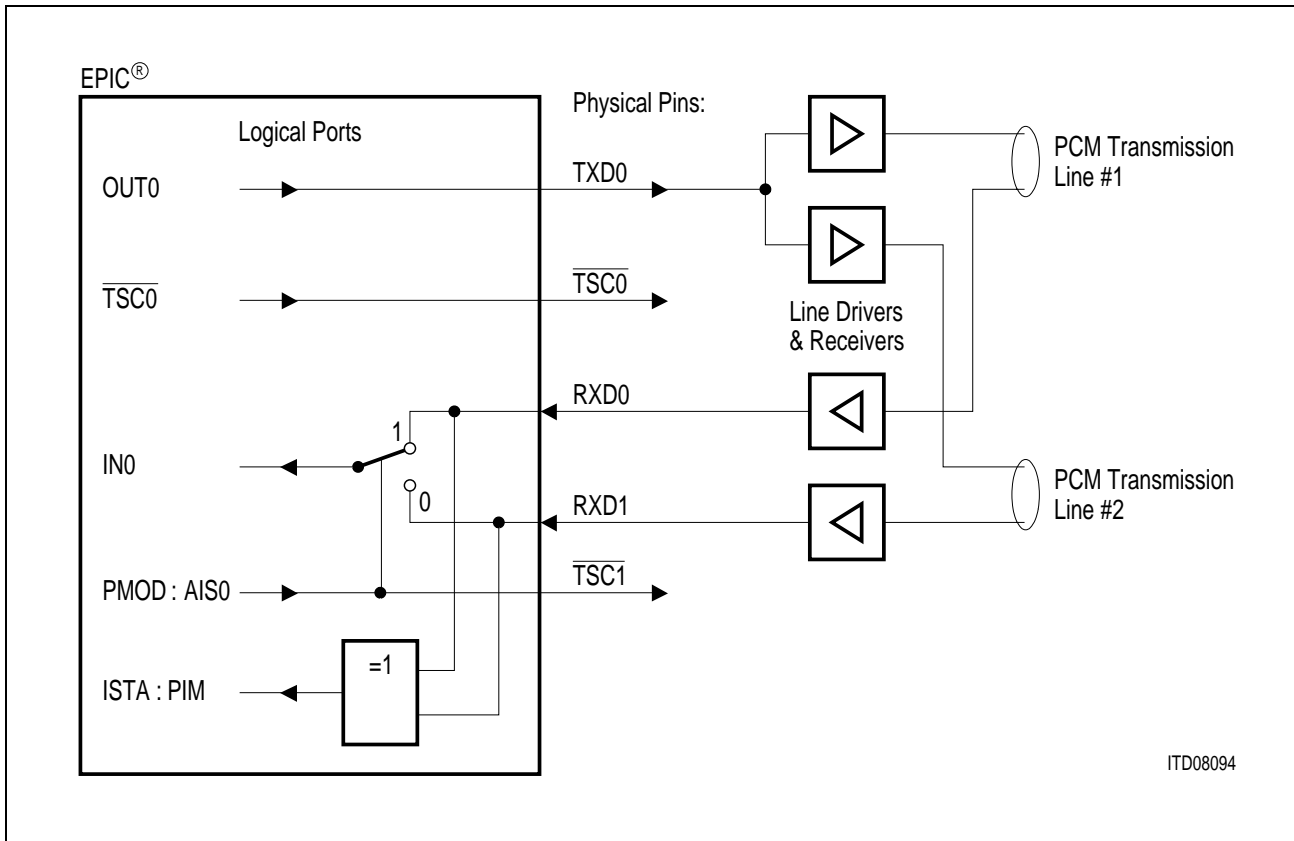

ITD08094

Figure 78
Connection of Redundant PCM Transmission Lines to the EPIC®

5.8.3 PCM Framing Supervision

Usually the repetition rate of the applied framing pulse PFS is identical to the frame period (125 μ s). If this is the case, the 'loss of synchronism indication function' can be used to supervise the clock and framing signals for missing or additional clock cycles. The EPIC internally checks the PFS period against the duration expected from the programmed clock rate. The clock rate corresponds to the frequency applied to the PDC pin. The number of clock cycles received within one PFS period is compared with the values programmed to PBNR (number of bits per frame) and PMOD:PCR (single/double clock rate operation). If for example single clock rate operation with 24 time slots per frame is programmed, the EPIC expects 192 clock cycles within one PFS period. The synchronous state is reached after the EPIC has detected two consecutive correct frames. The synchronous state is lost if one erroneous frame is found. The synchronization status (gained or lost) can be read from the STAR register (PSS bit) and each status change generates an interrupt (ISTA:PFI).

It should be noted that the framing supervision function is optional, i.e. it is also allowed to apply a PFS signal having a period of several frame periods e.g. 4 kHz, 2 kHz, The STAR:PSS bit will then be at logical 0 all the time, which does however not affect the proper operation of the EPIC.

5.9 Applications

5.9.1 Analog IOM[®]-2 Line Card with SICOFI[®]-4 as Codec/Filter Device

The line card consists of an EPIC (PEB 20550) device which handles the monitor and the signaling channels of up to 16 SICOFI-4 (PEB 2465) devices. Since each SICOFI-4 supports four analog lines, up to 64 analog subscriber lines (t/r lines) can be accommodated.

Figure 79 shows the interconnection of the EPIC, and the SICOFI-4 devices via the IOM-2 interface:

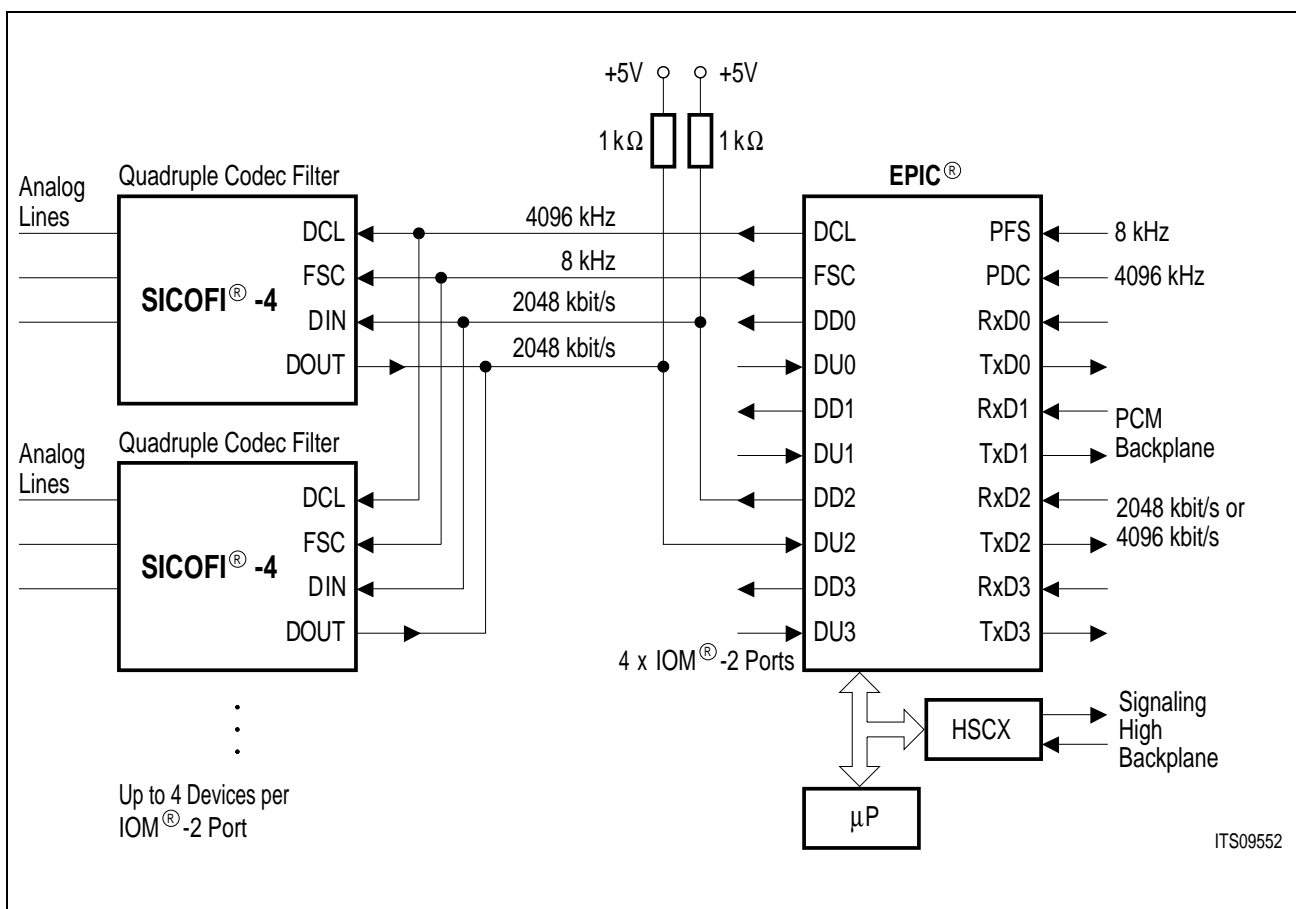

Figure 79
Analog Line Card with SICOFI[®]-4 Devices Using the IOM[®]-2 Interface

A typical timing example for the connection of the line card to a 2.048 Mbit/s PCM backplane is shown in figure 80. It should be noted that the PCM interface must be clocked with a 4.096 MHz clock even if the PCM interface operates at only 2.048 Mbit/s. This is to obtain a DCL output frequency of 4.096 MHz, which is required for the IOM-2 timing.

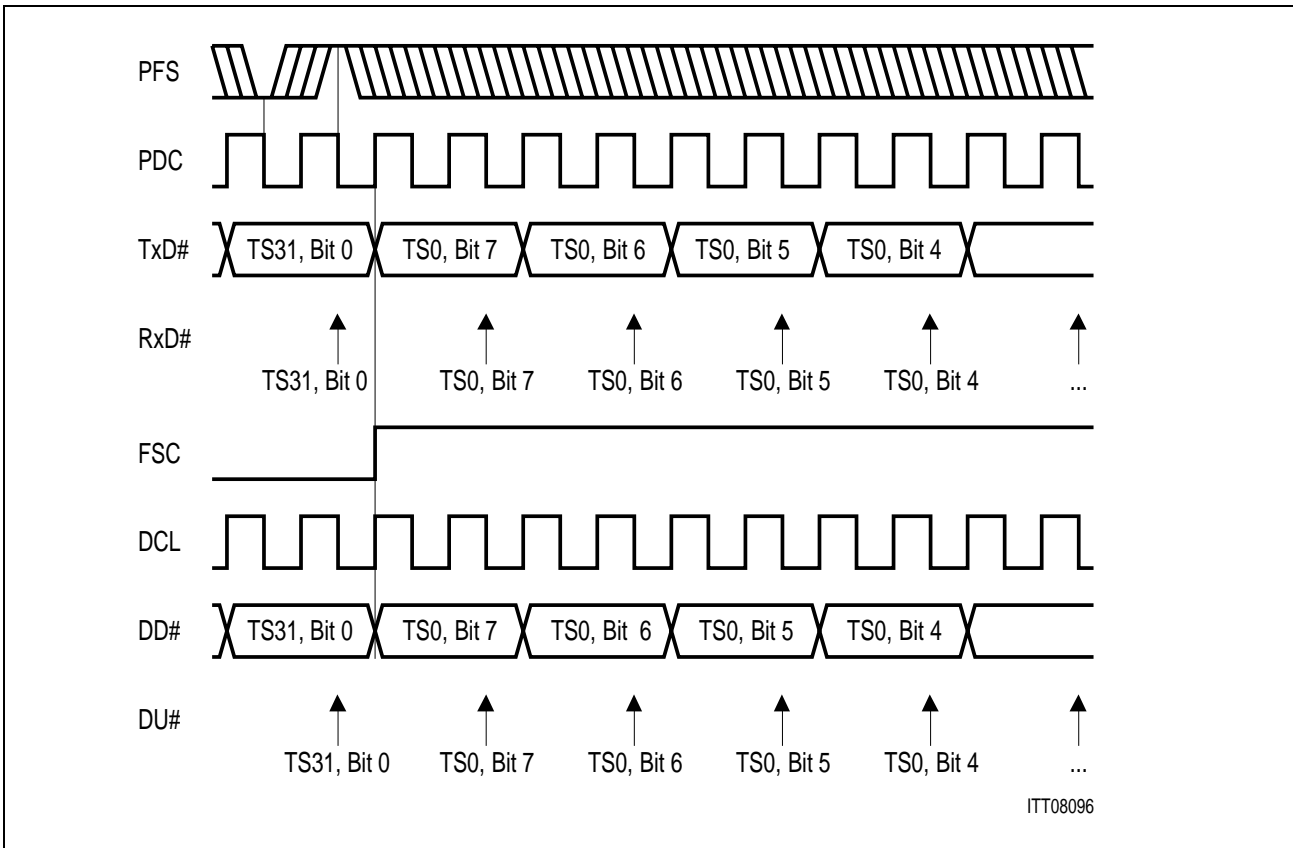

Figure 80
Typical IOM[®]-2 Line Card Timing

Based on these PCM and CFI timing requirements, the following EPIC initialization values for the PCM and CFI registers are recommended:

EPIC[®]

- PMOD = 0010 0000_B = 20_H PCM mode 0, double rate clock, PFS evaluated with falling clock edge, PCM comparison disabled
- PBNR = 1111 1111_B = FF_H 256 bits (32 ts) per PCM frame
- POFD = 1111 0000_B = F0_H PFS marks downstream PCM TS0, bit 7
- POFU = 0001 1000_B = 18_H PFS marks upstream PCM TS0, bit 7
- PCSR = 0000 0001_B = 01_H PCM data received with falling, transmitted with rising clock edge
- CMD1 = 0010 0000_B = 20_H PDC/PFS clock source, PFS evaluated with falling clock edge, prescaler = 1, CFI mode 0
- CMD2 = 1101 0000_B = D0_H FC mode 6, double rate clock, CFI data transmitted with rising, received with falling clock edge
- CBNR = 1111 1111_B = FF_H 256 bits (32 ts) per CFI frame

Application Hints

CTAR = 0000 0010_B = 02_H PFS marks downstream CFI TS0
 CBSR = 0010 0000_B = 20_H PFS marks downstream CFI bit 7, upstream bits not shifted
 CSCR = 0000 0000_B = 00_H 64, 32, 16 kbit/s channels located on CFI TS bits 7 ... 0, 7 ... 4, 7 ... 6

Each SICOFI-4 device must be assigned to its individual IOM-2 channels by pin-strapping. The SICOFI-4 coefficients (filter characteristics, gain, ...) as well as other operation parameters, are programmed via the ELIC over the IOM-2 monitor channel.

Example

Initializing 4 consecutive CFI time slots as an analog IOM-2 channel.

Time slots 0, 1, 2, and 3 of CFI port 2 shall represent the IOM channel 0 of port 2. Time slots 4, 5, 6, and 7 of CFI port 2 shall represent the IOM channel 1 of port 2. This requires the SICOFI-4 to be pin-strapped to that slot by connecting pin TSS0 and pin TSS1 to 0 V.

Time slots 4 and 5 represent the two B channels that may for example be switched to the PCM interface. Time slots 6 and 7 represent the monitor and signaling (SIG) channels and must be initialized in the ELIC control memory (CM):

W: MADR = FF_H ; 6 bit signaling value to be transmitted in time slot 7
 W: MAAR = 1C_H ; CFI address of downstream IOM port 2, time slot 6
 W: MACR = 7A_H ; writing CM with code '1010'
 W: MADR = FF_H ; value don't care, e.g. FF
 W: MAAR = 1D_H ; CFI address of downstream IOM port 2, time slot 7
 W: MACR = 7B_H ; writing CM with code '1011'
 W: MADR = FF_H ; 6 bit signaling value expected upon initialization in time slot 7
 W: MAAR = 9C_H ; CFI address of upstream IOM port 2, time slot 6
 W: MACR = 7A_H ; writing CM with code '1010'
 W: MADR = FF_H ; 6 bit signaling value expected upon initialization in time slot 7
 W: MAAR = 9D_H ; CFI address of upstream IOM port 2, time slot 7
 W: MACR = 7A_H ; writing CM with code '1010'

The above steps have to be repeated for all time slots that shall be handled by the monitor or signaling handler of the EPIC (i.e. TS2 and TS3, TS10 and TS11, TS14 and TS15).

Example for programming the CODEC corresponding to TS6 of the SICOFI-4:

```

W: OMDR = EEH ; activation of ELIC with active handshake protocol
W: MFSAR = 0EH ; monitor address for port 2, time slot 6
W: CMDR = 01H ; MFFIFO reset
R: STAR = 25H ; MFFIFO write access enabled
W: MFFIFO = 81H ; SICOFI-4 monitor address
W: MFFIFO = 14H(94H) ; SICOFI-4 channel A (B) data
W: MFFIFO = 00H ; SICOFI-4 data
W: MFFIFO = 00H ; SICOFI-4 data
W: MFFIFO = 00H ; SICOFI-4 data
W: MFFIFO = 00H ; SICOFI-4 data
W: CMDR = 04H ; transmit command
  
```

Wait for interrupt!

```

R: ISTA = 20H; MFFI interrupt
R: STAR = 25H; transfer completed, MFFIFO write access enabled
  
```

Reading back data from SICOFI-4:

```

W: MFSAR = 0EH ; monitor address for port 2, time slot 6
W: CMDR = 01H ; MFFIFO reset
R: STAR = 25H ; MFFIFO write access enabled
W: MFFIFO = 81H ; SICOFI-4 monitor address
W: MFFIFO = 65H(E5H) ; SICOFI-4 channel A (B) data, read back request
W: CMDR = 08H ; transmit and receive command
  
```

Wait for interrupt!

```

R: ISTA = 20H ; MFFI interrupt
R: STAR = 26H ; transfer completed, MFFIFO not empty, read access
                enabled
R: MFFIFO = 81H ; SICOFI-4 monitor address
R: MFFIFO = 00H ; SICOFI-4 data
R: MFFIFO = 00H ; SICOFI-4 data
R: MFFIFO = 00H ; SICOFI-4 data
R: MFFIFO = 00H ; SICOFI-4 data
R: STAR = 27H ; transfer completed, MFFIFO empty, read access enabled
  
```

5.9.2 IOM[®]-2 Trunk Line Applications

Trunk lines connect the PBX to the central office (CO) network. **Figure 81** gives an overview of the different access possibilities to the central office.

One possibility is to use analog a/b lines. This is the most uncomplicated way since no clock recovery from the CO is required, i.e. the PBX operates with a free running crystal oscillator. The t/r access to the CO can easily be realized with one or several SICOFI-2 or SICOFI-4 codec/filter devices, which allow the connection of two or four analog lines per chip.

If an access to the ISDN world is desired, two options are possible:

For small PBXs, with only few external lines, one or several Basic Rate ISDN (BRI) connections are best suited. Each BRI connection provides a capacity of two B channels of 64 kbit/s and one D channel of 16 kbit/s. The BRI connection is usually performed via the T interface to the Network Terminator 1 (NT1). The T interface is physically identical to the S interface, all Siemens S₀ interface devices (QUAT-S, SBCX, ISAC-S, SBC) can be used for that purpose. A PBX can also be connected directly via the U_k- interface to the CO. In this case an IEC-Q device (2B1Q encoding) or an IEC-T (4B3T encoding) can be used as layer-1 device.

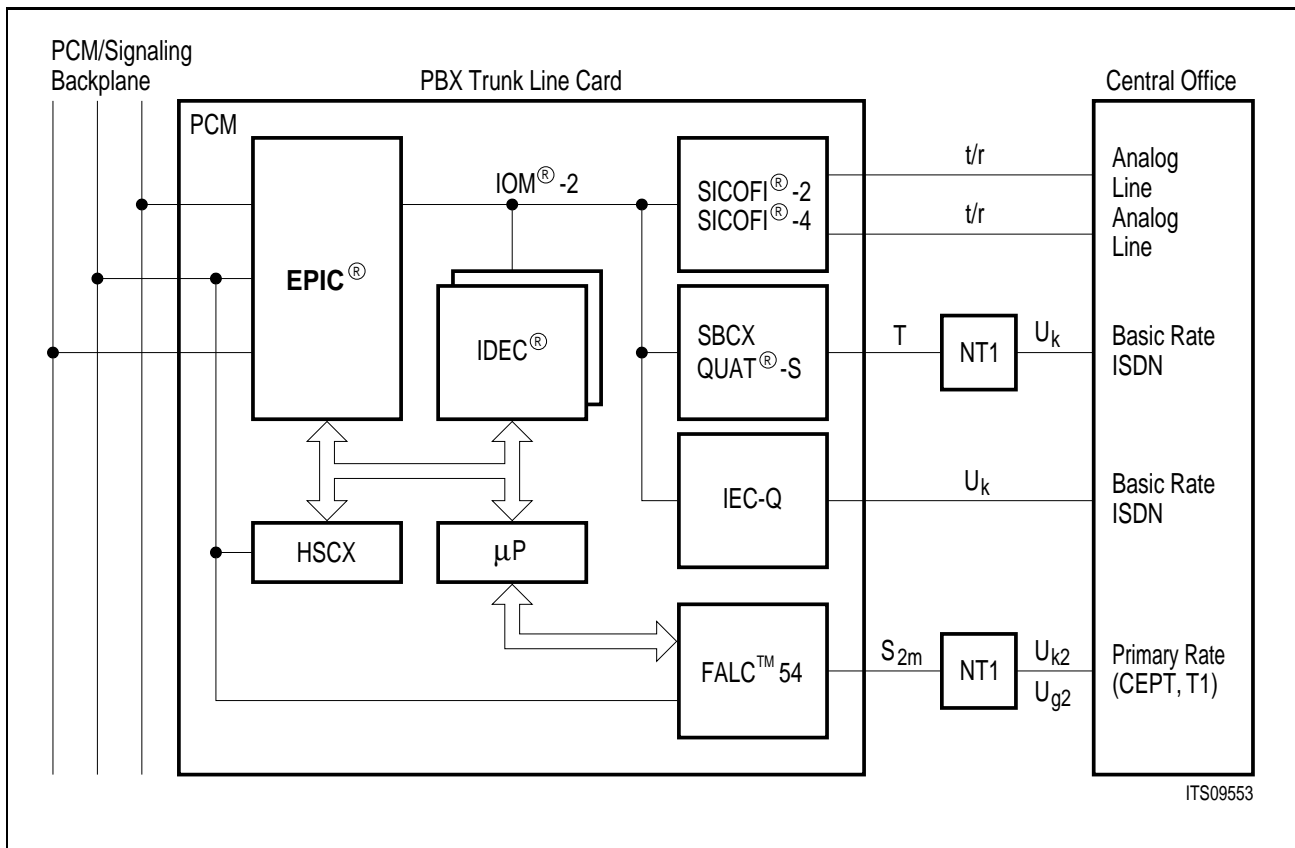

Figure 81
Overview of Trunk Line Applications

For large PBXs, with many external lines, one or several Primary Rate ISDN (PRI) connections are more advantageous. If the European CEPT standard is used, each PRI connection provides 30 B channels of 64 kbit/s each and one D channel of 64 kbit/s. The FALC54 can be used to implement the Primary Rate S_{2m} interface according to the CEPT (2.048 Mbit/s) or the T1 (1.544 Mbit/s) standards. For both standards a common backplane data rate of 2.048 or 4.096 Mbit/s can be selected to simplify the connection to the PBX internal PCM highway, which usually consists of 32 or 64 time slots.

Digital trunk lines require a clock recovery from the received data stream such that the PBX clock system is locked up with the CO clock system. The examples given in the following chapters show how to deal with these points.

5.9.2.1 PBX With Multiple ISDN Trunk Lines

In a trunk unit special attention must be given to the clock synchronization. The PBX clock generator must deliver a stable free running clock as long as no external calls are active. When an external call is established, the CO must be taken as reference to synchronize the local PBX clock system.

The Siemens S_0 -layer-1 transceivers SBC, SBCX, QUAT-S and ISAC-S are prepared for this kinds of applications: In the LT-T (Line Termination at the T-reference point) mode, they deliver a clock signal that is synchronous to the incoming S-frame. This clock signal can be taken to synchronize the PCM clocks of the EPIC by means of a XTAL controlled PLL circuit. Since the EPIC generates the IOM-2 clocks for the connected layer-1 and layer-2 devices, the loop is closed. If several layer-1 devices are operated in LT-T mode, only 1 device may be selected to deliver the reference clock. The PBX software must determine an active line by evaluating the C/I indications of the layer-1 devices in order to select an appropriate clock source for the PLL. If several external lines are active, any of these lines can be taken, since the CO lines are synchronous among each other.

The layer-1 devices have a built-in frame buffer that compensates the phase offset that may persist between the IOM-2 frame and the S_0 -frame. This buffer is 'elastic', such that a frame wander and jitter between the IOM-2 and the S-frame can be tolerated up to a certain extent. The maximum 'wander' value is device specific. For the SBCX, for example, 50 μ s of frame deviation are internally compensated. If this value is exceeded, a frame slip occurs that is reported to the μ P by a 'slip' indication in the C/I code. If a frame slip occurs, the data of an S-frame may be lost or transferred twice. The slip indications can be evaluated for statistical purposes. However, in a final design with optimized PLL tracking, slips should not occur during normal operation of the PBX.

Since the S_0 interface allows bus configurations for terminals (TEs), and since it is physically possible to connect a PBX trunk line together with other PBX trunk lines, or with normal ISDN terminals, to a common S-bus, the trunk lines must also follow the D-channel access procedure specified for ISDN terminals. This D-channel access procedure is implemented in the QUAT-S, ISAC-S and SBCX devices and can optionally

Application Hints

be set. If not required, the D-channel can also be sent transparently. If the QUAT-S is used together with the IDEC as layer-2 controller, the IDEC must be informed about the availability of the D-channel at the T-interface. The QUAT-S provides an enable signal at pin DRDY that carries this information during the D-channel time slot. This signal can be connected to the collision data input (CDR) of the IDEC to enable or disable HDLC transmission. The IDEC must then be programmed to the 'slave mode' in order to evaluate the CDR pin.

Figure 82 illustrates a complete PBX trunk card, where the EPIC controls up to 8 QUAT-S devices connected to up to 4 IOM-2 ports. On each IOM-2 port 2 IDECs take care of the D-channel processing. The CDR input lines of the IDECs are connected with the DRDY output pins of the QUAT-S. This is to stop the HDLC controllers in case of a D-channel collision on the T-bus. The QUAT-S devices must be programmed via the monitor channel to deliver appropriate Stop/Go information at pin DRDY. The 1.536 MHz reference clock outputs (pin CLK1) of the QUAT-Ss are fed via a multiplexer to the PBX clock generator. The μ P controls the multiplexer as required by the state of the lines.

Initialization values for the IDEC that controls the lower 4 channels of the IOM-2 interface:

IDEC®

| | | | |
|--------|--------------|-------------------|--|
| CCR | = 1000 0010B | = 82 _H | IOM-2 mode, IOM ch. 0 - 3, double clock rate, 256 bits/frame |
| A_MODE | = 0000 1100B | = 0C _H | uncond. trans., 16 kbit/s ch., channel and receiver active |
| A_TSR | = 0000 1100B | = 0C _H | ch. A time slot position: D channel of IOM ch. 0 |
| B_MODE | = 0000 1100B | = 0C _H | uncond. trans., 16 kbit/s ch., channel and receiver active |
| B_TSR | = 0001 1100B | = 1C _H | ch. B time slot position: D channel of IOM ch. 1 |
| C_MODE | = 0000 1100B | = 0C _H | uncond. trans., 16 kbit/s ch., channel and receiver active |
| C_TSR | = 0010 1100B | = 2C _H | ch. C time slot position: D channel of IOM ch. 2 |
| D_MODE | = 0000 1100B | = 0C _H | uncond. trans., 16 kbit/s ch., channel and receiver active |
| D_TSR | = 0011 1100B | = 3C _H | ch. D time slot position: D channel of IOM ch. 3 |

Initialization values for the IDEC that controls the upper 4 channels of the IOM-2 interface:

IDEC®

| | | | |
|--------|--------------|-------------------|--|
| CCR | = 1000 0010B | = A2 _H | IOM-2 mode, IOM ch. 4-7, double clock rate, 256 bits/frame |
| A_MODE | = 0000 1100B | = 0C _H | uncond. trans., 16 kbit/s ch., channel and receiver active |
| A_TSR | = 0100 1100B | = 4C _H | ch. A time slot position: D channel of IOM ch. 4 |
| B_MODE | = 0000 1100B | = 0C _H | uncond. trans., 16 kbit/s ch., channel and receiver active |
| B_TSR | = 0101 1100B | = 5C _H | ch. B time slot position: D channel of IOM ch. 5 |
| C_MODE | = 0000 1100B | = 0C _H | uncond. trans., 16 kbit/s ch., channel and receiver active |
| C_TSR | = 0110 1100B | = 6C _H | ch. C time slot position: D channel of IOM ch. 6 |
| D_MODE | = 0000 1100B | = 0C _H | uncond. trans., 16 kbit/s ch., channel and receiver active |
| D_TSR | = 0111 1100B | = 7C _H | ch. D time slot position: D channel of IOM ch. 7 |

The ELIC initialization is the same as for the IOM-2 application described previously in this chapter.

If the D-channel access procedure is programmed, the IDEC MODE registers must additionally be programmed accordingly i.e. for each channel MODE = 2C_H (instead of 0C_H).

Example

In a first step, the QUAT-S in IOM port 0, ch. 0 ... 3 is programmed via the IOM-2 monitor handler to the LT-T mode:

```

W:OMDR    = EEH      ; activation ELIC with handshake protocol enabled
W:MFSAR   = 04H      ; monitor address of IOM port 0, channel 0
W:CMDR    = 01H      ; reset MFFIFO
R:STAR    = 25H      ; MFFIFO write access enabled
W:MFFIFO  = 81H      ; select QUAT-S Configuration Register
W:MFFIFO  = 41H      ; set LT-T mode, output CLK1
W:CMDR    = 04H      ; transmit MFFIFO content
R:ISTA    = 20H      ; MFFI interrupt
W:MFSAR   = 0CH      ; monitor address of IOM port 0, channel 1
W:CMDR    = 01H      ; reset MFFIFO
R:STAR    = 25H      ; MFFIFO write access enabled
W:MFFIFO  = 81H      ; select QUAT-S Configuration Register
W:MFFIFO  = 01H      ; set LT-T mode
W:CMDR    = 04H      ; transmit MFFIFO content
R:ISTA    = 20H      ; MFFI interrupt
W:MFSAR   = 14H      ; monitor address of IOM port 0, channel 2
W:CMDR    = 01H      ; reset MFFIFO
R:STAR    = 25H      ; MFFIFO write access enabled
W:MFFIFO  = 81H      ; select QUAT-S Configuration Register
W:MFFIFO  = 01H      ; set LT-T mode
W:CMDR    = 04H      ; transmit MFFIFO content
R:ISTA    = 20H      ; MFFI interrupt
W:MFSAR   = 1CH      ; monitor address of IOM port 0, channel 3
W:CMDR    = 01H      ; reset MFFIFO
R:STAR    = 25H      ; MFFIFO write access enabled
W:MFFIFO  = 81H      ; select QUAT-S Configuration Register
W:MFFIFO  = 01H      ; set LT-T mode
W:CMDR    = 04H      ; transmit MFFIFO content
R:ISTA    = 20H      ; MFFI interrupt
    
```

5.9.2.2 Small PBX

Figure 83 shows a realization example of a small PBX. If the total number of lines (internal or external) is smaller than the capacity of the EPIC ($32 \times (2 \times B + D)$ or $64 \times B$), the PCM interface of the EPIC need not to be connected to a switching network since all the B (and D) channel switching can be done inside the EPIC. In this special case, it is sufficient to apply only a PCM clock to the EPIC, the PCM frame synchronization signal (8 kHz) can be omitted. The IOM-2 clock and framing signals DCL and FSC are still generated correctly by the EPIC. The STAR:PSS bit should then not be evaluated: it stays at logical 0 all the time.

The PBX shown in the **figure 83** offers 8 analog (t/r) subscriber lines, realized with two quadruple codec/filter devices SICOFI-4 (PEB 2465). These can of course be replaced by any IOM-2 compatible layer-1 device if digital lines are required. Any mixture of codecs and digital layer-1 devices is also feasible.

The **figure 83** also shows a digital trunk line (external line) which is realized with a U_k -layer-1 device, IEC-Q (PEB 2091), operated in NT-PABX mode. The PBX can therefore be connected directly to the U_k interface coming from the CO. The NT-PABX mode of the U_k -layer-1 devices is similar to the LT-T mode of the S layer-1 devices: in both cases the layer-1 device delivers a reference clock which is synchronous to the received S or U_k -frame and that can be used to synchronize the local PBX clock generator. Any phase differences between the local IOM-2 frame and the received S or U_k -frame are compensated by an elastic buffer inside the layer-1 devices.

Since the digital trunk line also needs a D channel handler, an ISDN Communication Controller (ICC; PEB 2070) is assigned to that IOM-2 channel.

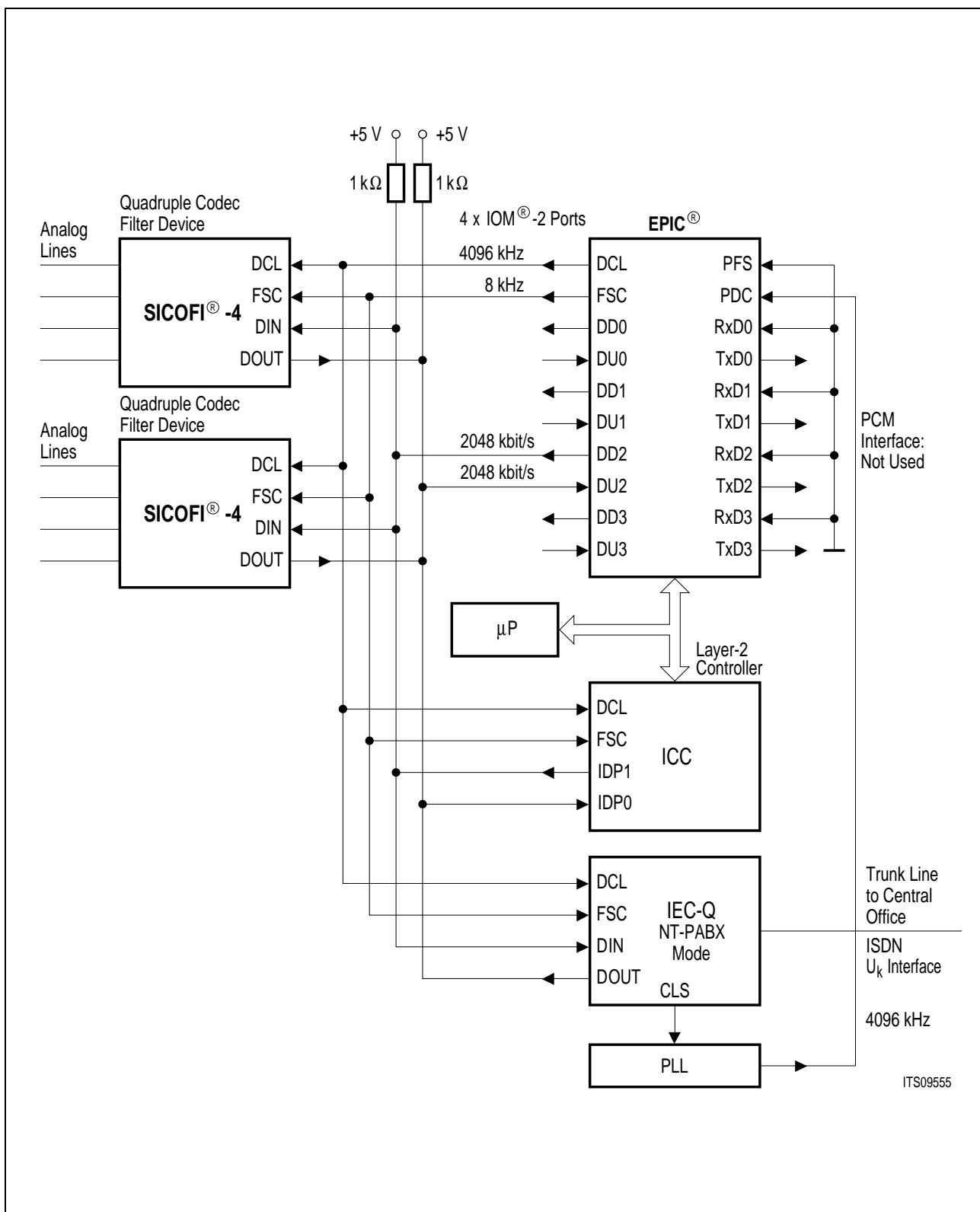

Figure 83
Small PBX with SICOFI[®]-4 and IEC-Q

5.9.3 Miscellaneous

5.9.3.1 Interfacing the EPIC® to a MUSAC™

The PCM interface of the EPIC can easily be connected to the Multipoint Switching and Conferencing circuit MUSAC (PEB 2245) when using the set-up and PCM timing as shown in **figure 84**. This configuration can then for example be used in a PBX to implement conferencing functions for up to 21 simultaneous conferences.

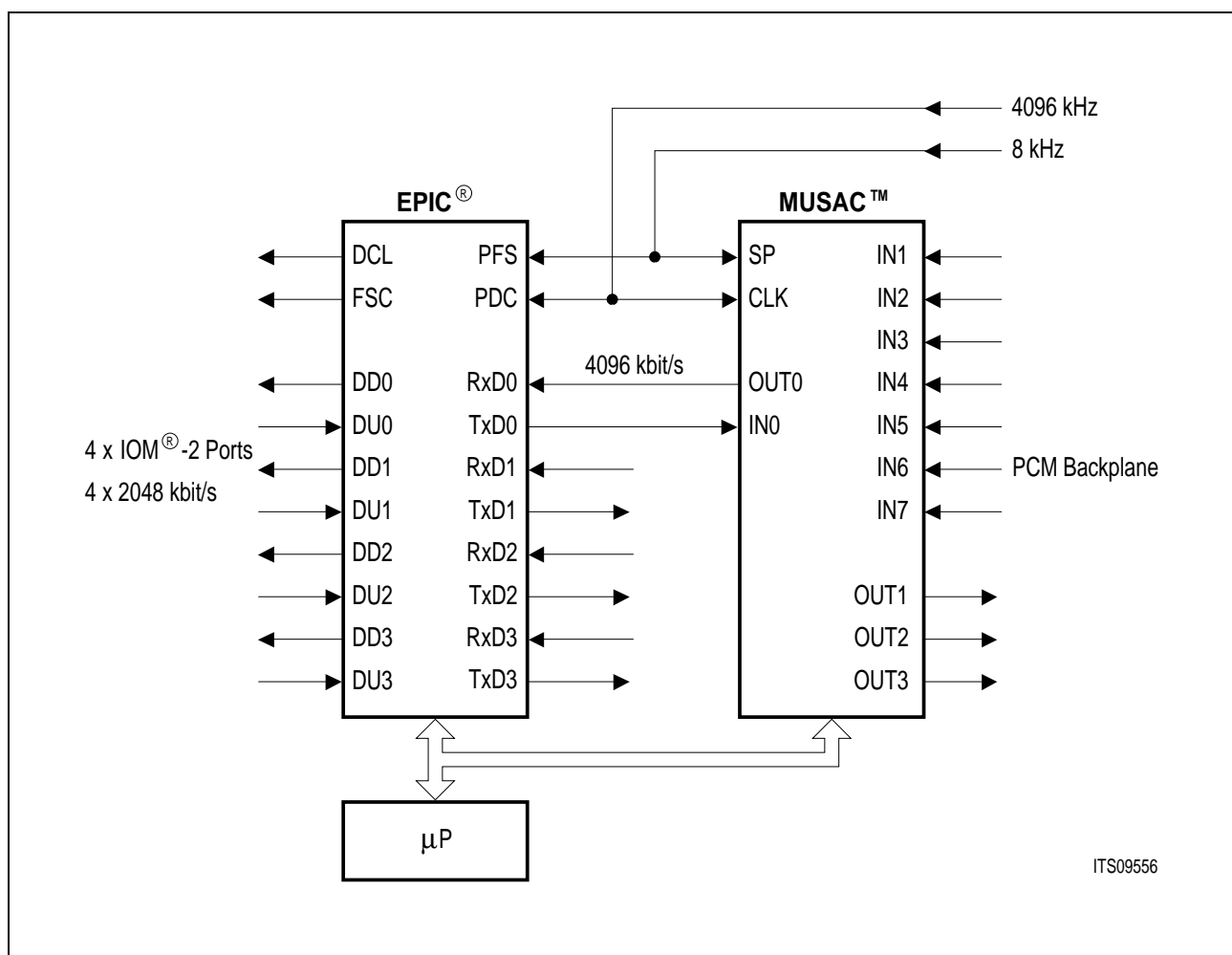

Figure 84
Interconnection Example EPIC® - MUSAC™

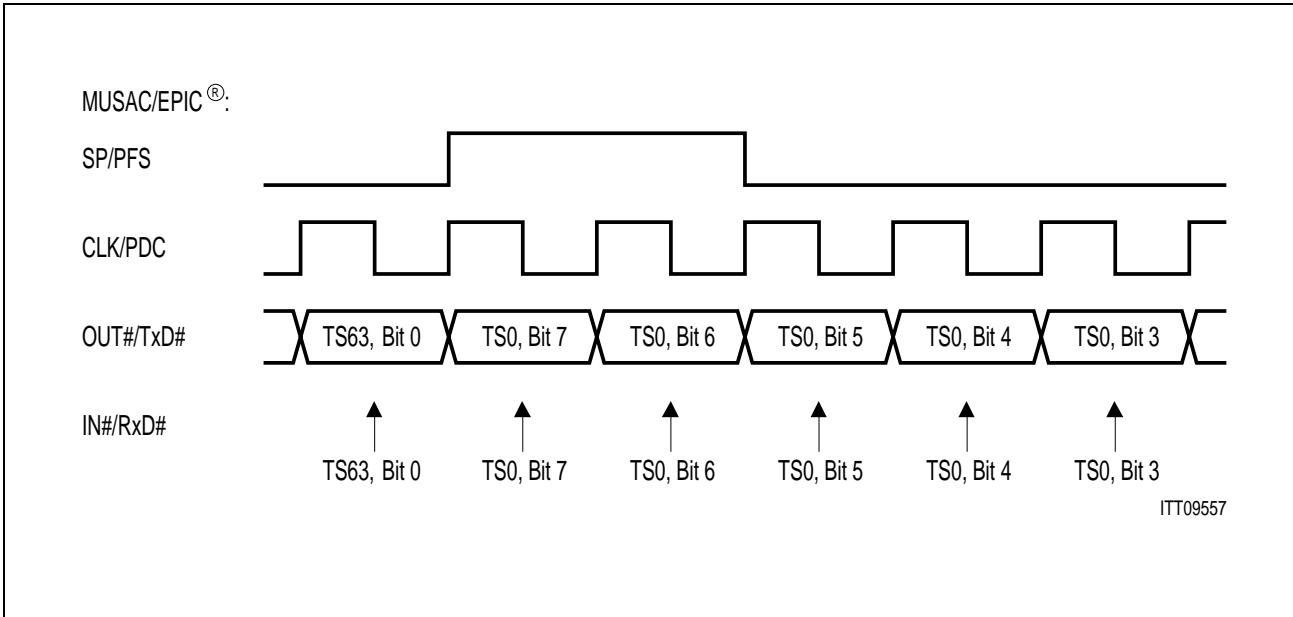

Figure 85
Timing Example to Interconnect the EPIC® and the MUSAC™ on an IOM®-2 Line Card

The following values must be programmed to the PCM and CFI registers of the EPIC and to the MOD and CFR registers of the MUSAC to obtain the desired PCM and IOM-2 timing:

EPIC®

| | | | |
|------|--------------------------|-------------------|--|
| PMOD | = 0100 0100 _B | = 44 _H | PCM mode 1, single rate clock, PFS evaluated with falling clock edge, input selection RxD0 and RxD3, PCM comparison disabled |
| PBNR | = 1111 1111 _B | = FF _H | 512 bits (64 ts) per PCM frame |
| POFD | = 1111 0000 _B | = F0 _H | PFS marks downstream PCM TS0, bit 6 |
| POFU | = 0001 1000 _B | = 18 _H | PFS marks upstream PCM TS0, bit 6 |
| PCSR | = 0100 0101 _B | = 45 _H | PCM data received with falling, transmitted with rising clock edge |
| CMD1 | = 0010 0000 _B | = 20 _H | PDC/PFS clock source, PFS evaluated with falling clock edge, prescaler = 1, CFI mode 0 |
| CMD2 | = 1101 0000 _B | = D0 _H | FC mode 6, double rate clock, CFI data transmitted with rising, received with falling clock edge |
| CBNR | = 1111 1111 _B | = FF _H | 256 bits (32 ts) per CFI frame |

Application Hints

| | | | |
|------|--------------------------|-------------------|--|
| CTAR | = 0000 0010 _B | = 02 _H | PFS marks downstream CFI TS0 |
| CBSR | = 0010 0000 _B | = 20 _H | PFS marks downstream CFI bit 6, upstream bits not shifted |
| CSCR | = 0000 0000 _B | = 00 _H | 64, 32, 16 kbit/s channels located on CFI bits 7 ... 0, 7 ... 4, 7 ... 6 |

MUSAC™

| | | | |
|-----|--------------------------|-------------------|--|
| MOD | = 0100 0100 _B | = 03 _H | input mode 8 × 4M, output mode 4 × 4M |
| CFR | = 1111 1111 _B | = DE _H | 4.096 MHz device clock, conferencing mode, A-law, even bits inverted |

5.9.3.2 Space and Time Switch for 16 kbit/s Channels

The EPIC is optimized for the space and time switching of 64 kbit/s channels (8 bit time slots). The switching of 32 and 16 kbit/s subchannels is also supported, but these channels can only be freely selected at the PCM interface. At the CFI, only one subchannel per 8 bit time slot can be switched (see **chapter 5.4.2**). Usually, this is sufficient because on the IOM-2 interface, only one 16 kbit/s D channel per time slot needs to be switched. Up to four D channels may then be combined into a single 8 bit PCM time slot.

If a completely flexible space and time switch for contiguous 16 kbit/s channels is required, the following method can be used:

The four CFI ports are connected in parallel as shown in **figure 86**. Each CFI port is programmed via the CFI subchannel register (CSCR) to handle a different 2 bit subtime slot position. With this configuration, any mixture of 16, 32 and 64 kbit/s channels may be switched between the CFI and the PCM interfaces. Up to 128 16 kbit/s channels per direction can be handled by the EPIC. The switching software must select the CFI port number according to the required CFI subchannel position for each CFI - PCM connection. The PCM subchannel position is selected via the control memory (CM) code field (see **table 24**). For 32 and 64 kbit/s connections, only one CFI port of a given time slot may be programmed in order to avoid collisions on the CFI "bus".

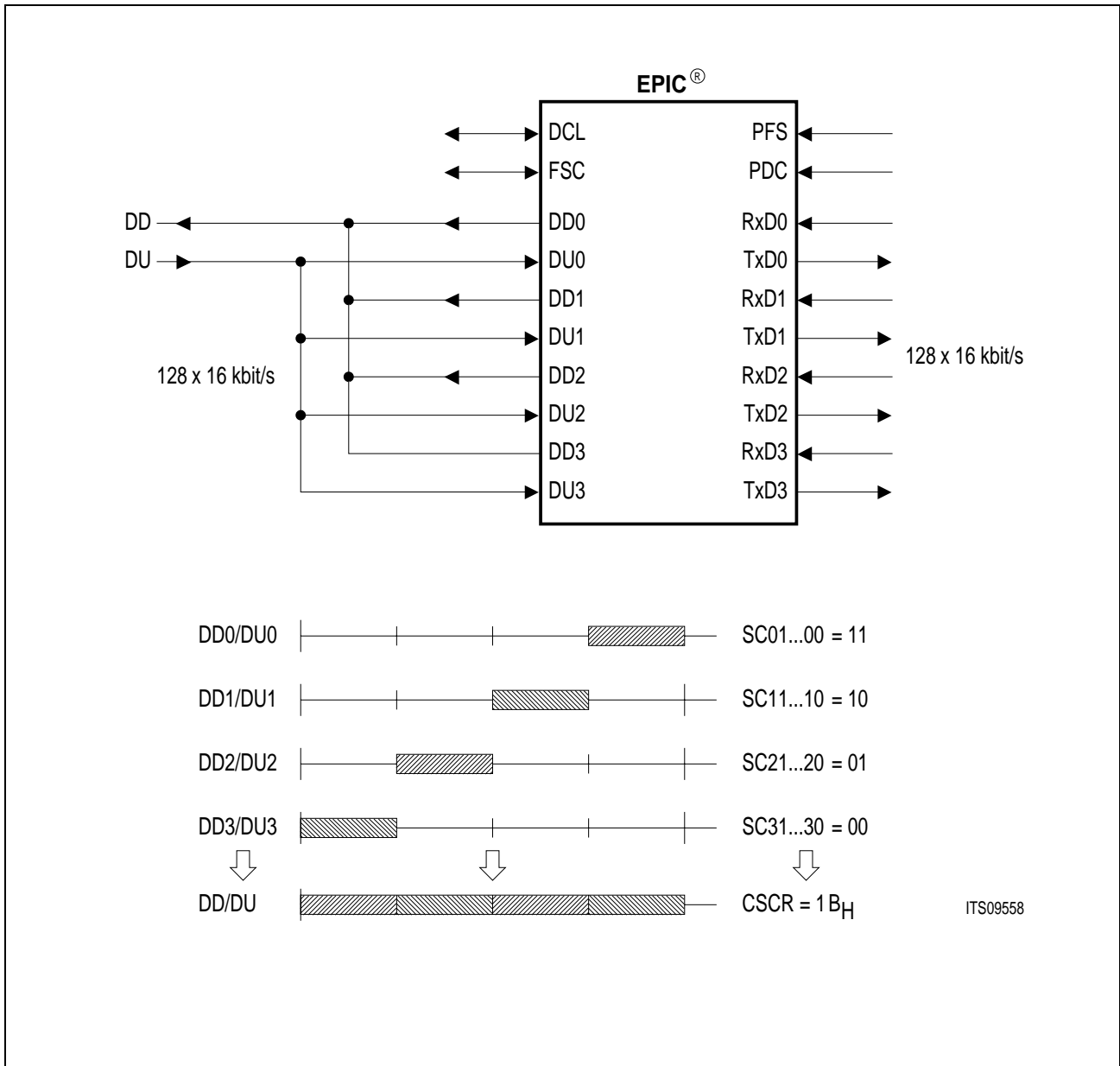

Figure 86
Non-blocking Space and Time Switch for 16 kbit/s Channels

5.9.3.3 Interfacing an IOM[®]-2 Terminal Mode Interface to a 2.048 Mbit/s PCM Backplane

For some applications, it is necessary to connect IOM-2 terminal devices (e.g. ARCOFI, PSB 2160) to a PCM backplane. In such a configuration, the EPIC can be used as a rate adaptor between these two differing data rates. Since the internal prescalers of the EPIC cannot be used to convert the 2.048 Mbit/s (PCM) into 768 kbit/s (IOM-2 terminal mode), an external clock converting circuit as shown in **figure 87** has to be built up. A PLL controlled oscillator generates the IOM-2 data clock of 1.536 MHz by comparing the PCM clock divided by 4 with the DCL clock divided by 3.

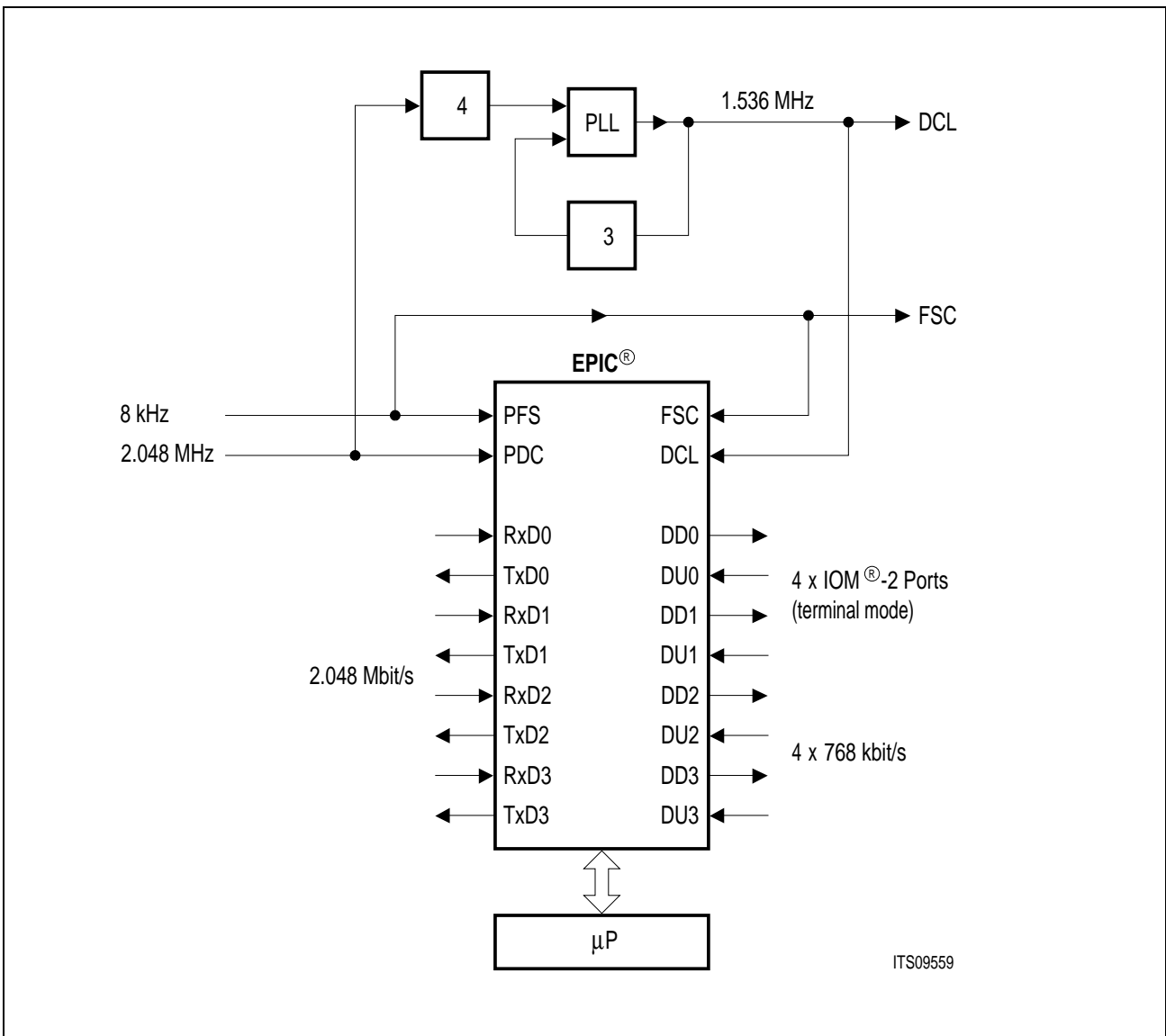

Figure 87
Interface Circuit to adapt the IOM[®]-2 (768 kbit/s) and PCM (2.048 Mbit/s) Data Rates

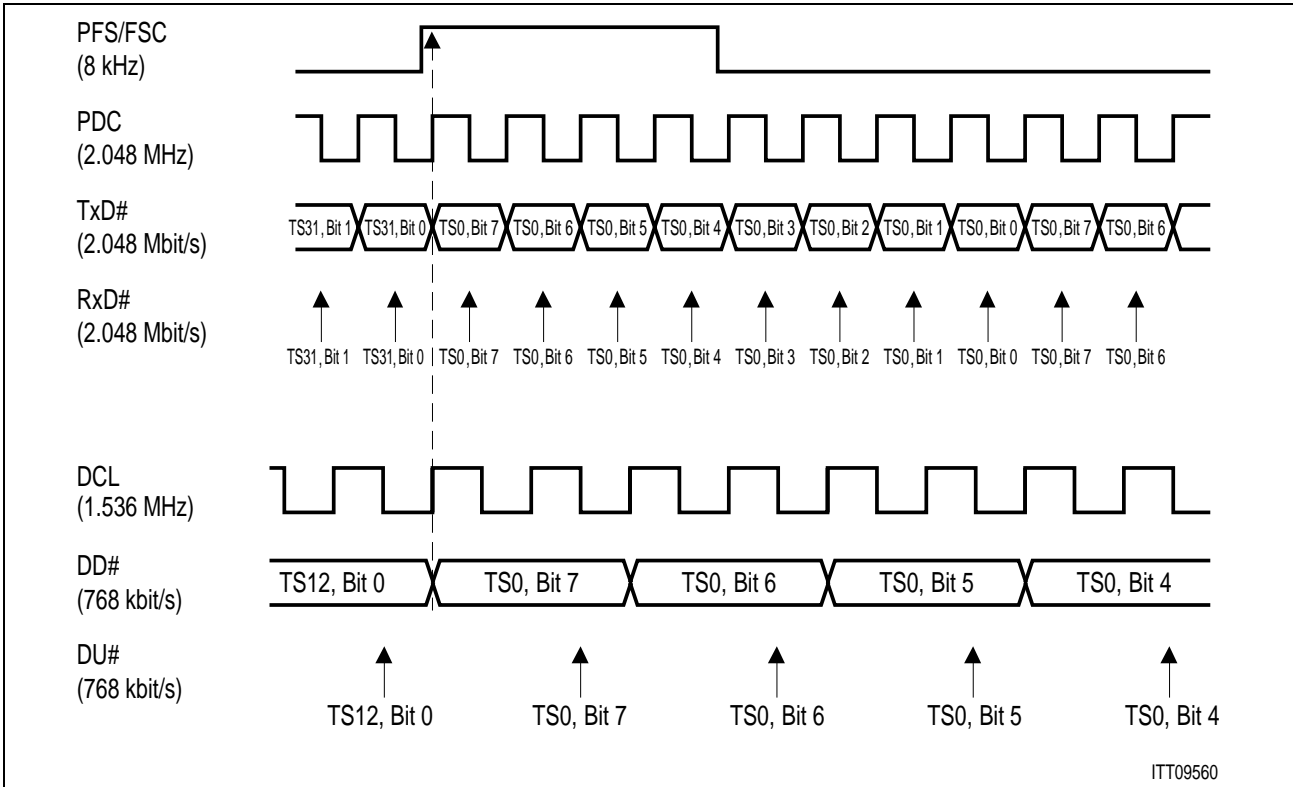

Figure 88
IOM[®]-2 (768 kbit/s) and PCM (2.048 Mbit/s) Timing Example

If the PCM input clock timing of **figure 88** applies, the following values have to be written to the EPIC to obtain the correct PCM and CFI timing:

EPIC[®]

| | | | |
|------|--------------------------|-------------------|--|
| PMOD | = 0010 0000 _B | = 20 _H | PCM mode 0, single rate clock, PFS evaluated with rising clock edge, PCM comparison disabled |
| PBNR | = 1111 1111 _B | = FF _H | 256 bits (32 ts) per PCM frame |
| POFD | = 1111 0000 _B | = F0 _H | PFS marks downstream PCM TS0, bit 7 |
| POFU | = 0001 1000 _B | = 18 _H | PFS marks upstream PCM TS0, bit 7 |
| PCSR | = 0000 0001 _B | = 01 _H | PCM data received with falling, transmitted with rising clock edge |
| CMD1 | = 1110 0000 _B | = E0 _H | DCL/FSC clock source, FSC evaluated with rising clock edge, prescaler = 1, CFI mode 0 |
| CMD2 | = 0000 0000 _B | = 00 _H | CFI data transmitted with rising, received with falling clock edge |
| CBNR | = 0101 1111 _B | = 5F _H | 96 bits (12 ts) per CFI frame |
| CTAR | = 0000 0010 _B | = 02 _H | PFS marks downstream CFI TS0 |
| CBSR | = 0010 0000 _B | = 20 _H | PFS marks downstream CFI bit 7, upstream bits not shifted |
| CSCR | = 0000 0000 _B | = 00 _H | 64, 32, 16 kbit/s channels located on CFI bits 7 ... 0, 7 ... 4, 7 ... 6 |

Electrical Characteristics

6 Electrical Characteristics

Absolute Maximum Ratings

| Parameter | Symbol | Limit Values | | Unit |
|--|-----------|--------------|----------------|------|
| | | min. | max. | |
| Ambient temperature under bias: PEB PEF | T_A | 0 | 70 | °C |
| | T_A | -40 | 85 | °C |
| Storage temperature | T_{stg} | -65 | 125 | °C |
| Voltage on any pin with respect to ground | V_S | -0.4 | $V_{DD} + 0.4$ | V |
| Maximum voltage on any pin | V_{max} | | 6 | V |

Note: Stresses above those listed here may cause permanent damage to the device. Exposure to absolute maximum ratings conditions for extended periods may affect device reliability.

| Parameter | Symbol | Limit Values | | Unit | Test Condition |
|------------------------|-------------------------|----------------|----------------|------|--|
| | | min. | max. | | |
| L-input voltage | V_{IL} | -0.4 | 0.8 | V | |
| H-input voltage | V_{IH} | 2.2 | $V_{DD} + 0.4$ | | |
| L-output voltage | V_{OL} | | 0.45 | V | $I_{OL} = 7 \text{ mA}$ (pins DU3..0, DD3..0) $I_{OL} = 2 \text{ mA}$ (all other) |
| H-output voltage | V_{OH} | 2.4 | | V | $I_{OH} = -400 \mu\text{A}$ |
| H-output voltage | V_{OH} | $V_{DD} - 0.5$ | | V | $I_{OH} = -100 \mu\text{A}$ |
| Power supply current | operational I_{CC} | | 9.5 | mA | $V_{DD} = 5 \text{ V}$, inputs at 0 V or V_{DD} , no output loads PDC > 4.096 MHz PDC ≤ 4.096 MHz |
| | | | 6.5 | mA | |
| Input leakage current | I_{LI} | | 10 | μA | $0 \text{ V} < V_{IN} < V_{DD}$ to 0 V |
| Output leakage current | I_{LO} | | 10 | μA | $0 \text{ V} < V_{OUT} < V_{DD}$ to 0 V |

Note: The listed characteristics are ensured over the operating range of the integrated circuit. Typical characteristics specify mean values expected over the production spread. If not otherwise specified, typical characteristics apply at $T_A = 25^\circ\text{C}$ and the given supply voltage.

Electrical Characteristics

Capacitances

| Parameter | Symbol | Limit Values | | Unit |
|--------------------|-----------|--------------|------|------|
| | | min. | max. | |
| Input capacitance | C_{IN} | | 10 | pF |
| Output capacitance | C_{OUT} | | 15 | pF |
| I/O | $C_{I/O}$ | | 20 | pF |

AC Characteristics

Ambient temperature under bias range, $V_{DD} = 5\text{ V} \pm 5\%$.

Inputs are driven to 2.4 V for a logical "1" and to 0.4 V for a logical "0".

Timing measurements are made at 2.0 V for a logical "1" and at 0.8 V for a logical "0".

The AC-testing input/output wave forms are shown below.

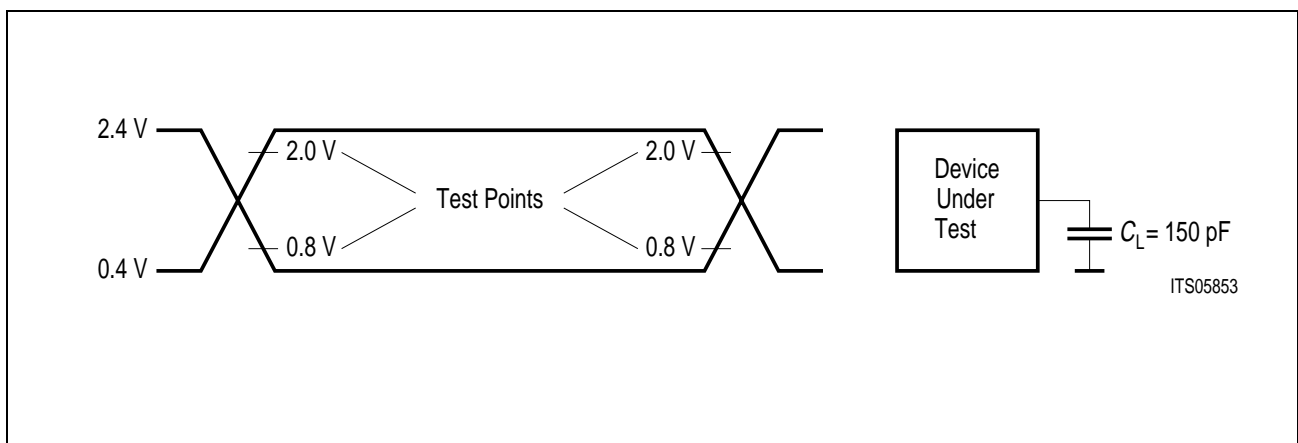

Figure 89
I/O-Wave Form for AC-Test

Electrical Characteristics

Bus Interface Timing

| Parameter | Symbol | Limit Values | | Unit |
|---|-----------|--------------|------|------|
| | | min. | max. | |
| R or \overline{W} set-up to \overline{DS} | t_{DSD} | 0 | | ns |
| \overline{RD} -pulse width | t_{RR} | 120 | | ns |
| \overline{RD} -control interval | t_{RI} | 70 | | ns |
| Data output delay from \overline{RD} | t_{RD} | | 100 | ns |
| Data float delay from \overline{RD} | t_{DF} | | 25 | ns |
| \overline{WR} -pulse width | t_{WW} | 60 | | ns |
| \overline{WR} -control interval | t_{WI} | 70 | | ns |
| Data set-up time to \overline{WRxCS} , \overline{DSxCS} | t_{DW} | 30 | | ns |
| Data hold time from \overline{WRxCS} , \overline{DSxCS} | t_{WD} | 10 | | ns |
| ALE-pulse width | t_{AA} | 30 | | ns |
| Address set-up time to ALE | t_{AL} | 10 | | ns |
| Address hold time from ALE | t_{LA} | 15 | | ns |
| ALE set-up time to \overline{WR} , \overline{RD} | t_{ALS} | 0 | | ns |
| Address set-up time to \overline{WR} , \overline{RD} | t_{AS} | 10 | | ns |
| Address hold time from \overline{WR} | t_{AH} | 40 | | ns |

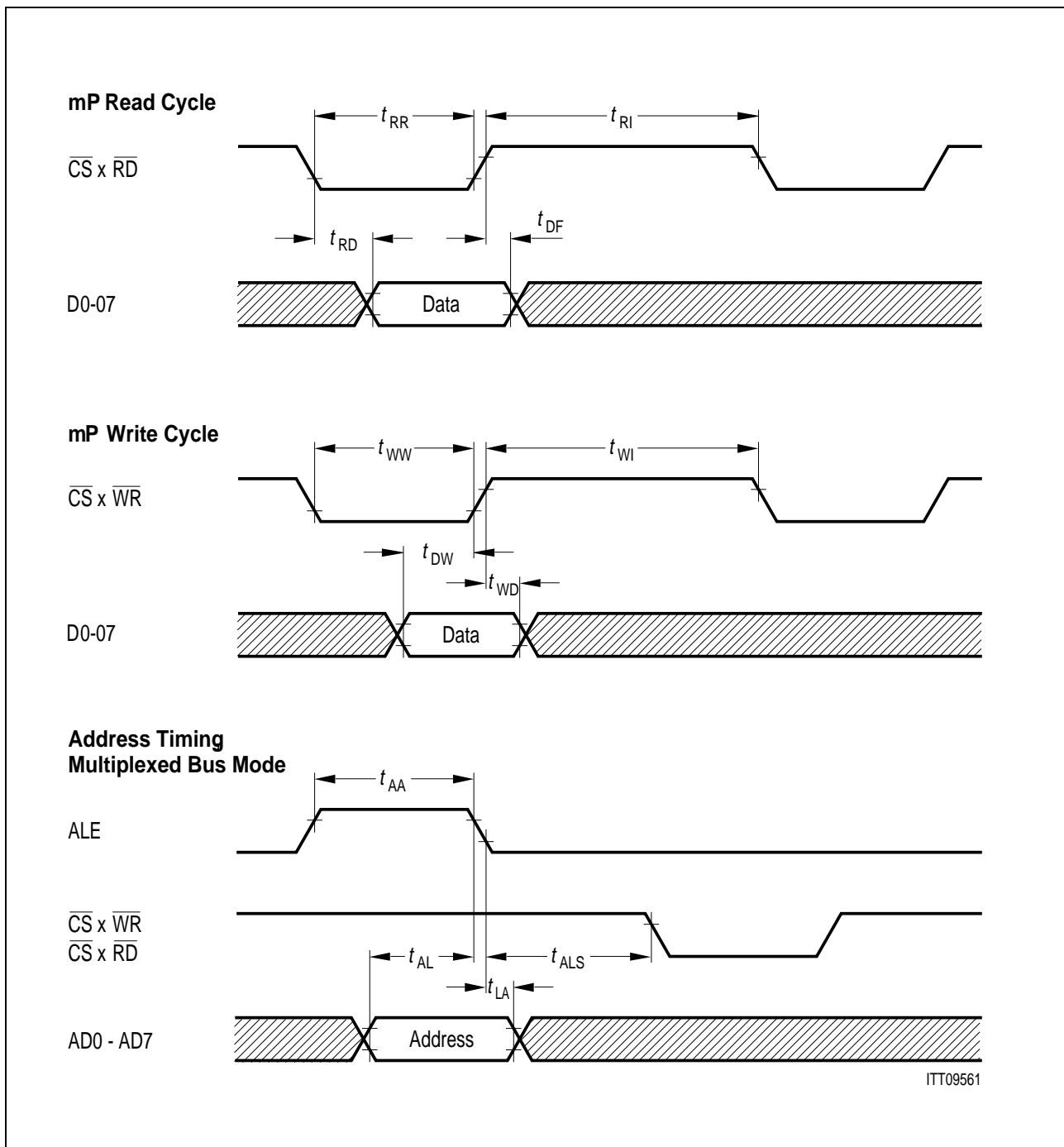

Figure 90
Siemens/Intel Bus Mode

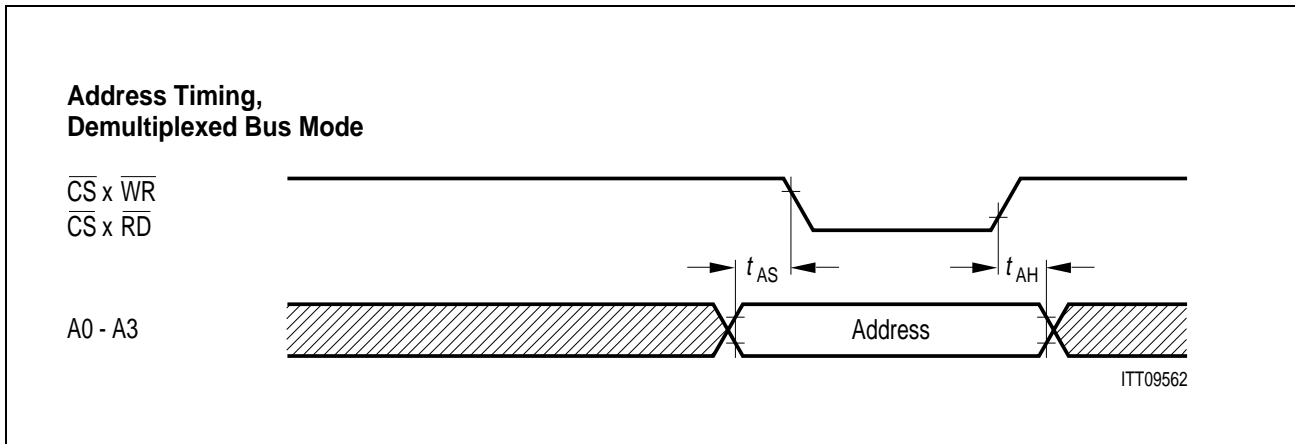

Figure 91
Siemens/Intel Bus Mode

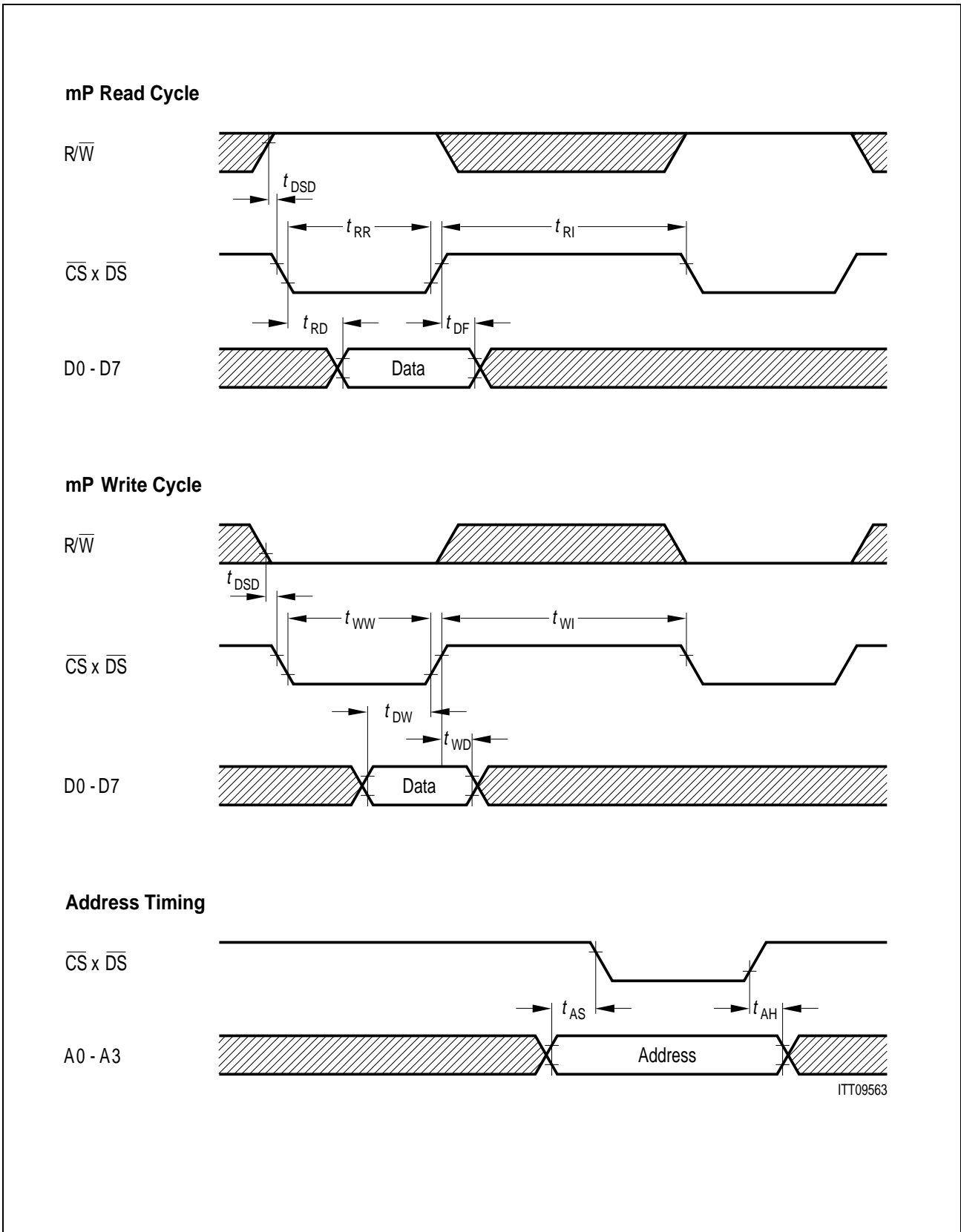

Figure 92
Motorola Bus Mode

Electrical Characteristics

PCM and Configurable Interface Timing

| Parameter | Symbol | Limit Values | | Unit | Test Condition |
|---|-----------|--------------|------|------|--|
| | | min. | max. | | |
| Clock period | t_{CP} | 240 | | ns | Clock frequency ≤ 4096 kHz |
| Clock period low | t_{CPL} | 80 | | ns | |
| Clock period high | t_{CPH} | 100 | | ns | |
| Clock period | t_{CP} | 120 | | ns | Clock frequency > 4096 kHz |
| Clock period low | t_{CPL} | 50 | | ns | |
| Clock period high | t_{CPH} | 50 | | ns | |
| Frame set-up time to clock | t_{FS} | 25 | | ns | |
| Frame hold time from clock | t_{FH} | 50 | | ns | |
| Data clock delay | t_{DCD} | | 125 | ns | ²⁾ |
| Serial data input set-up time (falling clock edge) | t_S | 7 | | ns | PCM-input data frequency > 4096 kbit/s |
| Serial data input set-up time (rising clock edge) | t_S | 15 | | ns | |
| Serial data hold time | t_H | 35 | | ns | |
| Serial data input set-up time | t_S | 15 | | ns | PCM-input data frequency ≤ 4096 kbit/s |
| Serial data hold time | t_H | 55 | | ns | |
| Serial data input set-up time | t_S | 20 | | ns | CFI-input data frequency > 4096 kbit/s |
| Serial data hold time | t_H | 50 | | ns | |
| Serial data input set-up time | t_S | 0 | | ns | CFI-input data frequency ≤ 4096 kbit/s |
| Serial data hold time | t_H | 75 | | ns | |
| PCM-serial data output delay | t_D | | 55 | ns | ¹⁾ |
| Tristate control delay | t_T | | 60 | ns | ¹⁾ |
| CFI-serial data output delay | t_{CDF} | | 65 | ns | Falling clock edge ²⁾ |
| CFI-serial data output delay | t_{CDR} | – | 90 | ns | Rising clock edge ²⁾ |

1) Parameter can be estimated to: $20 \text{ ns} + 0.25 \text{ ns} \times [C_L]$

2) The max. difference between T_{DCD} and T_{CDF} / T_{CDR} is $60 \text{ ns} / 35 \text{ ns}$

Electrical Characteristics

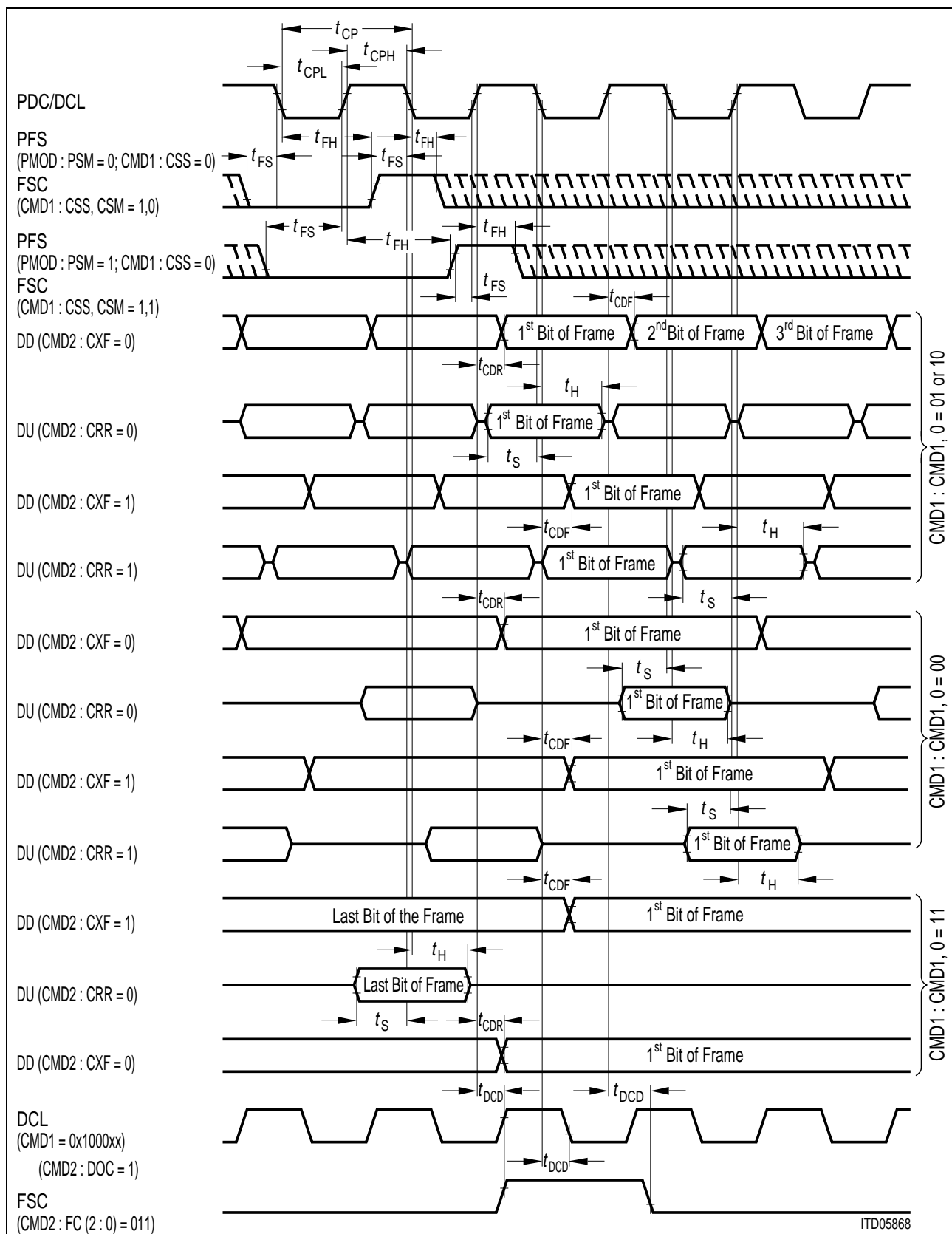

Figure 93
Configurable Interface Timing, CMD:CSP1,0 = 10 (prescaler divisor = 1)

Electrical Characteristics

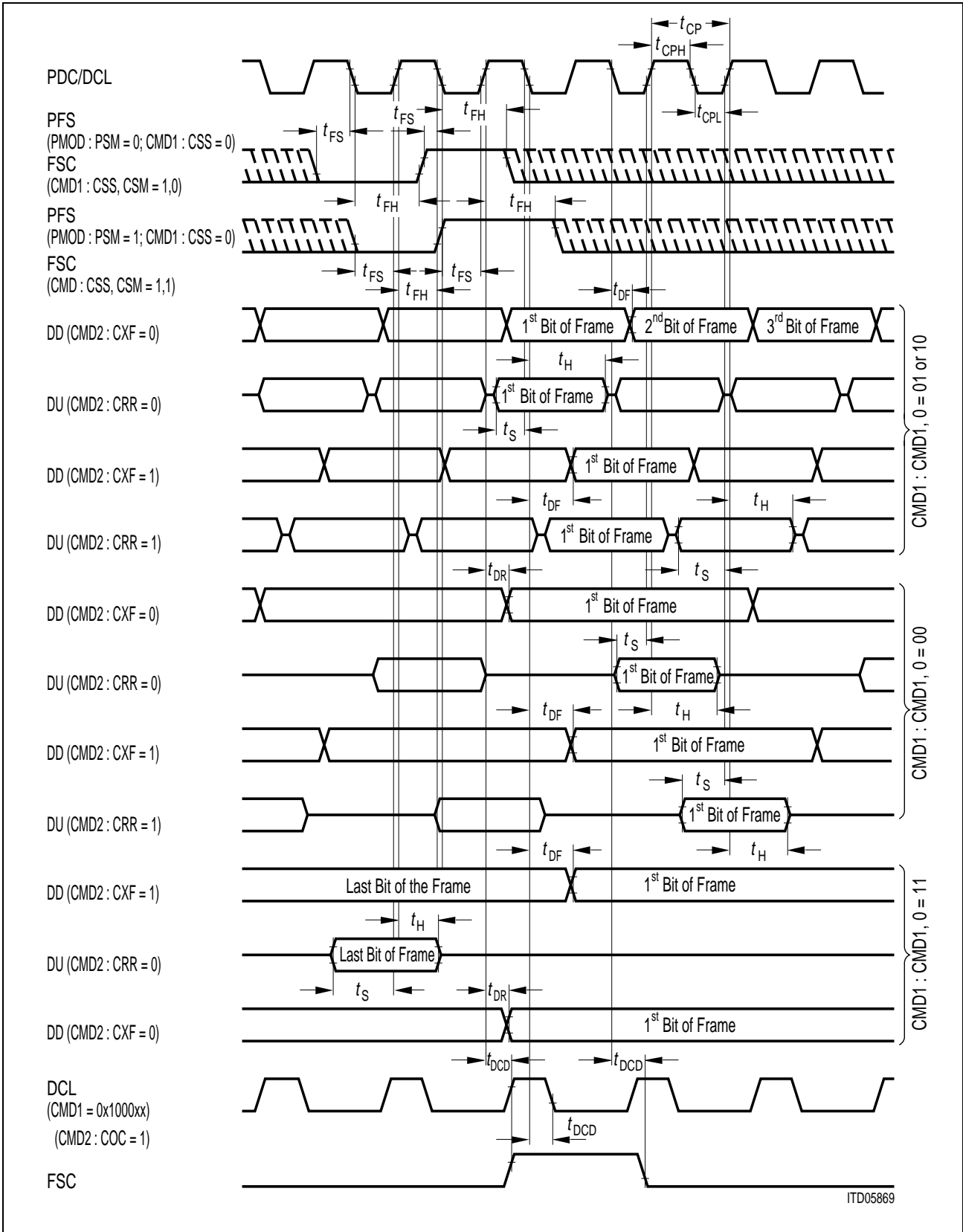

Figure 94
Configurable Interface Timing, CMD:CSP1,0 = 01 (prescaler divisor = 1,5)

Electrical Characteristics

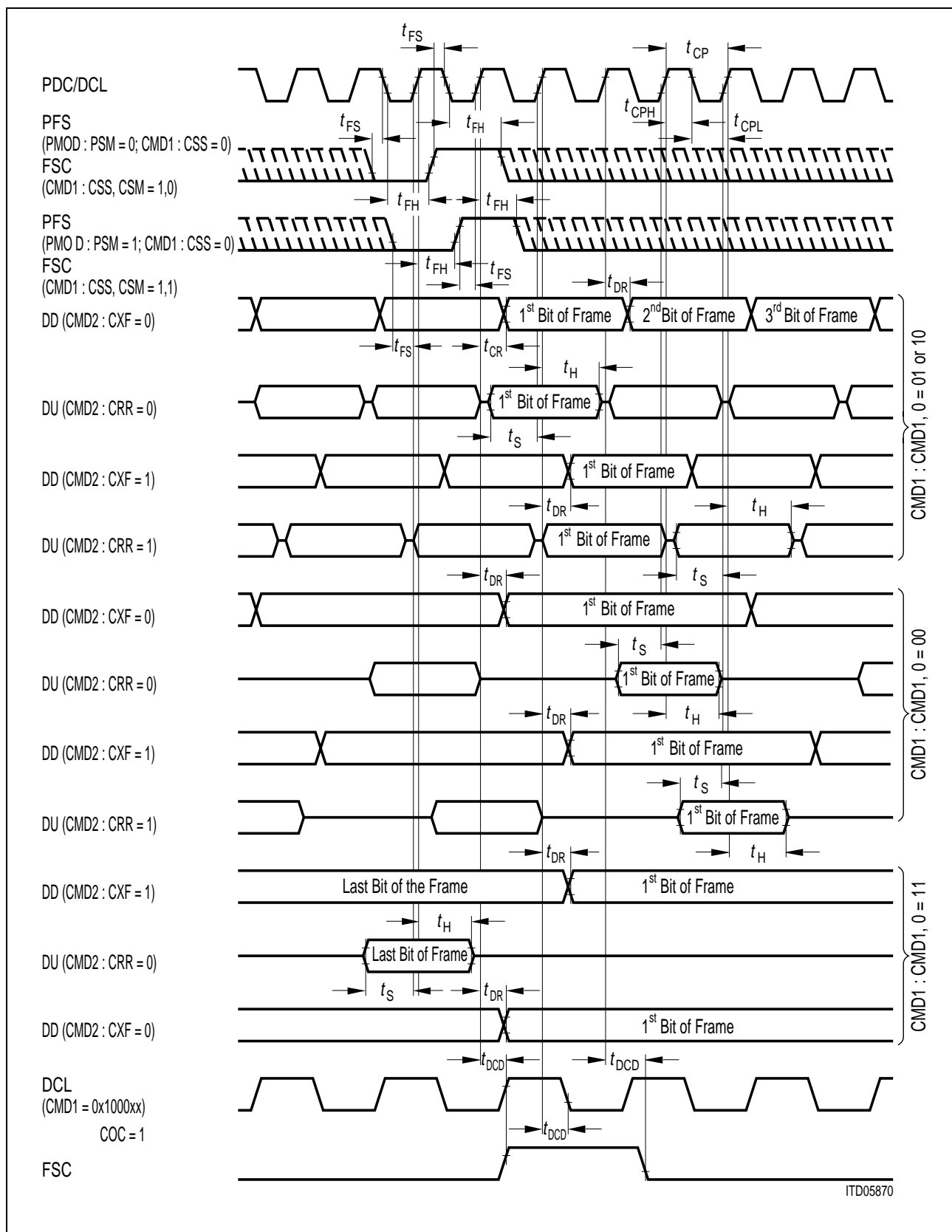

Figure 95
Configurable Interface Timing, CMD:CSP1,0 = 00 (prescaler divisor = 2)

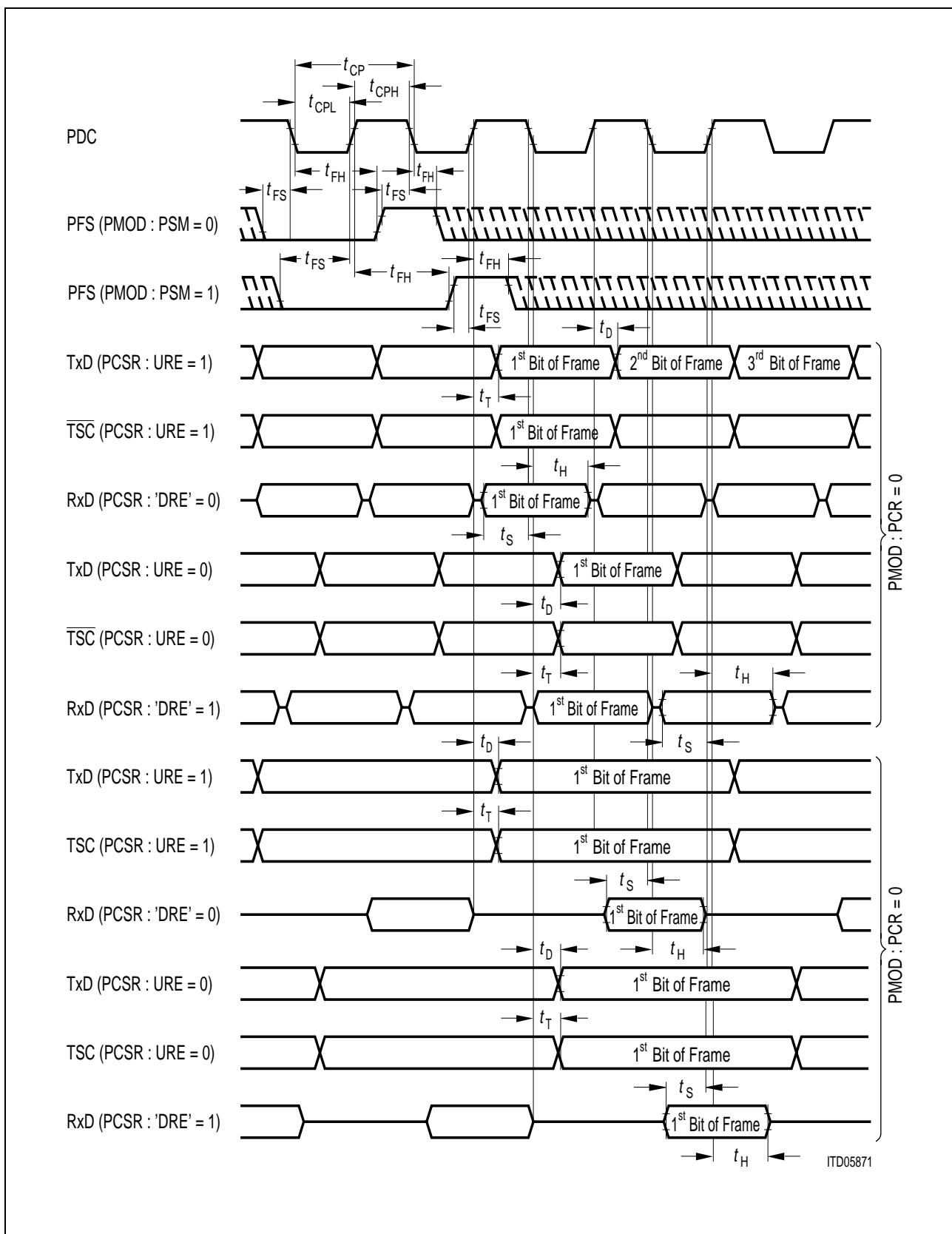
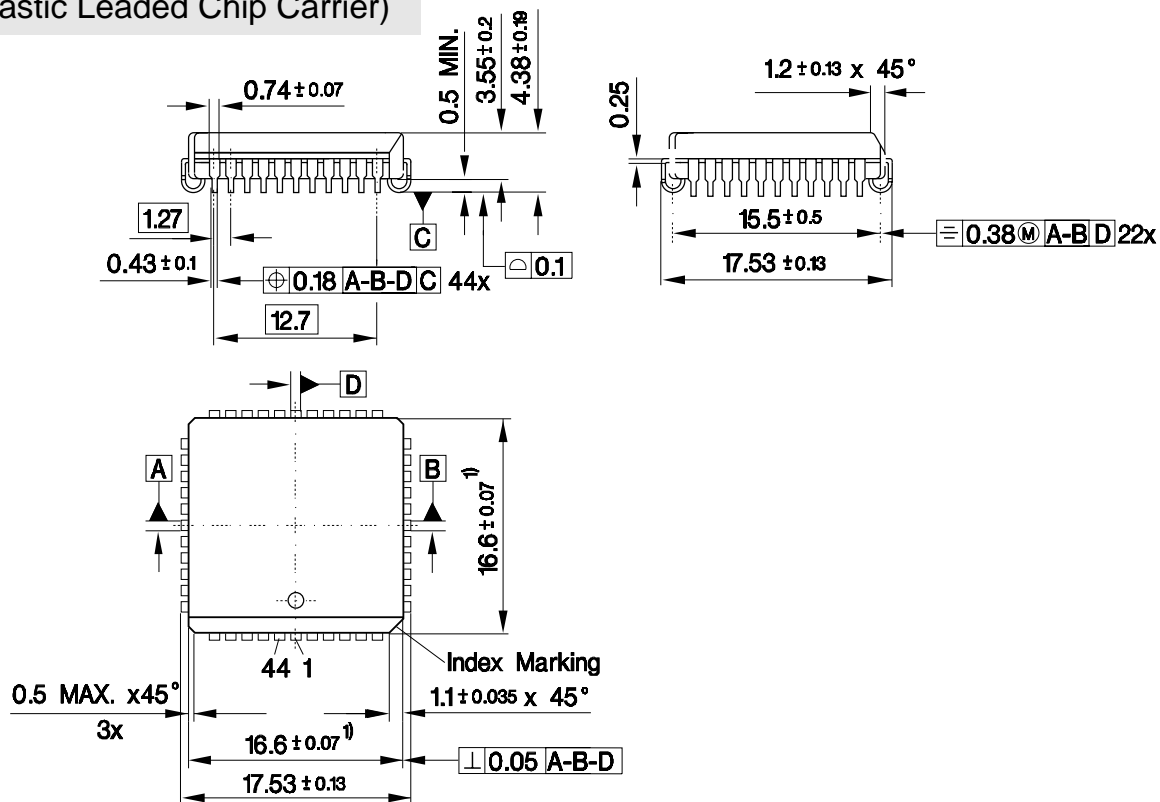

Figure 96
PCM-Interface Timing

7 Package Outlines

P-LCC-44-1

(Plastic Leaded Chip Carrier)



1) Does not include plastic or metal protrusion of 0.15 max. per side

GPM05249

Sorts of Packing

Package outlines for tubes, trays etc. are contained in our Data Book "Package Information"

SMD = Surface Mounted Device

Dimensions in mm

POFD PCM Offset Downstream Register RW, 24_H (2_H + RBS = 1), reset-val. = 0

| |
|---------|
| OFD9..2 |
|---------|

OFD2..9 = Offset Downstream (see PCSR for OFD0..1)

Mode 0: $(BND - 17 + BPF) \bmod BPF \rightarrow OFD2..9$

Mode 1: $(BND - 33 + BPF) \bmod BPF \rightarrow OFD1..9$

Mode 2: $(BND - 65 + BPF) \bmod BPF \rightarrow OFD0..9$

BND = number of bits + 1 that the downstream frame start is left shifted relative to the frame sync

BPF = number of bits per frame

Unused bits must be set to 0 !

POFU PCM Offset Upstream Register RW, 26_H (3_H + RBS = 1), reset-val. = 0

| |
|---------|
| OFU9..2 |
|---------|

OFU2..9 = Offset Upstream (see PCSR for OFU0..1)

Mode 0: $(BND + 23 + BPF) \bmod BPF \rightarrow OFU2..9$

Mode 1: $(BND + 47 + BPF) \bmod BPF \rightarrow OFU1..9$

Mode 2: $(BND + 95 + BPF) \bmod BPF \rightarrow OFU0..9$

BND = number of bits + 1 that the upstream frame is left shifted relative to the frame start

BPF = number of bits per frame

Unused bits must be set to 0 !

PCSR PCM Clock Shift Register RW, 28_H (4_H + RBS = 1), reset-val. = 0

| | | | | | |
|---|---------|-----|---|---------|-----|
| 0 | OFD1..0 | DRE | 0 | OFU1..0 | URE |
|---|---------|-----|---|---------|-----|

OFD0..1 = Offset Downstream (see POFD)

DRE = Downstream Rising Edge,

0 = receive data on falling edge,

1 = receive data on rising edge

OFU0..1 = Offset Upstream (see POFU)

URE = Upstream Rising Edge,

0 = send data on falling edge,

1 = send data on rising edge

Figure 98
EPIC® Initialization Register Summary (working sheet)

CFI Interface

CMD1 CFI Mode Register 1 RW, 2C_H (6_H + RBS = 1), reset-val.=00

| | | | | |
|-----|-----|---------|---------|---------|
| CSS | CSM | CSP1..0 | CMD1..0 | CIS1..0 |
|-----|-----|---------|---------|---------|

CSS = Clock Source Select,
0 = PDC/PFS used for CFI,
1 = DCL/FSC are inputs

CSM = CFI Synchronization Mode:
1 = frame syncr. with rising edge,
0 = falling edge of DCL

if CSS = 0 ==> CMD1:CSM = PMOD:PSM !

CSP0..1 = Clock Source Prescaler: 00 = 1/2, 01 = 1/1.5, 10 = 1/1

CMD0..1 = CFI Mode: 00 = 0, 01 = 1, 10 = 2, 11 = 3

CIS0..1 = CFI Alternative Input Section

Mode 0, 3: CIS0..1 = 0

Mode 1, 2: CIS0: 0 = IN0 = DU0, 1 = IN0 = DU2

Mode 1: CIS1: 0 = IN1 = DU1, 1 = IN1 = DU3

CMD2 CFI Mode Register 2 RW, 2E_H (7_H + RBS = 1), reset-val.=00

| | | | | |
|--------|-----|-----|-----|---------|
| FC2..0 | COC | CXF | CRR | CBN9..8 |
|--------|-----|-----|-----|---------|

For IOM[®]-2 CMD2 can be set to D0_H

FC0..2 = Framing Signal Output Control (CMD1:CSS = 0)

= 010 suitable for PBC, = 011 for IOM-2, = 110 IOM-2 and SLD

COC = Clock Output Control (CMD1:CSS = 0)

= 0 DCL = data rate,

= 1 DCL 2 × data rate (only mode 0 and 3 !)

CXF = CFI Transmit on Falling Edge: 0 = send on rising edge, 1 = send on falling DCL edge

CRR = CFI Receive on Rising Edge: 0 = receive on falling edge, 1 = send on rising DCL edge

CBN8..9 = CFI Bit Number (see CBNR)

CBNR CFI Bit Number Register RW, 30_H (8_H + RBS = 1), reset-val.=FF

| |
|-----|
| CBN |
|-----|

CBN0..7 = CFI Bit Number per Frame – 1 (see CMD2:CBN8..9)

Figure 99
EPIC[®] Initialization Register Summary (working sheet)

CTAR CFI Time Slot Adjustment Register RW, 32_H (9_H + RBS = 1), reset-val. = 00

| | |
|---|-----|
| 0 | TSN |
|---|-----|

TSN0..6 = (number of time slots + 2) the DU and DD frame is left shifted relative to frame start (see also CBSR)

CBSR CFI Bit Shift Register RW, 34_H (A_H + RBS = 1), reset-val. = 00

| | | |
|---|---------|---------|
| 0 | CDS2..0 | CUS3..0 |
|---|---------|---------|

CDS2..0: CFI Downstream/Upstream Bit Shift

Shift DU and DD frame:

- 000 = 2 bits right
- 001 = 1 bit right
- 010 = 6 bits left
- 011 = 5 bits left
- 100 = 4 bits left
- 101 = 3 bits left
- 110 = 2 bits left
- 111 = 1 bit left

Relative to PFS (if CMD1:CSS = 0)

Relative to FSC (if CMD1:CSS = 1)

CSCR CFI Subchannel Register RW, 36_H (A_H + RBS = 1), reset-val. = 00

| | | | |
|-----|-----|-----|-----|
| CS3 | CS2 | CS1 | CS0 |
|-----|-----|-----|-----|

SC3 0..1 control port 3 (+ port 7 for CFI mode 3 (SLD))

SC2 0..1 control port 2 (+ port 6 for CFI mode 3 (SLD))

SC1 0..1 control port 1 (+ port 5 for CFI mode 3 (SLD))

SC0 0..1 control port 0 (+ port 4 for CFI mode 3 (SLD))

for 64 kBit/s channel: 00/01/10/11 = bits 7..0

for 32 kBit/s channel: 00/10 = bits 7..4,

01/11 = bits 3..0

Figure 100
EPIC® Initialization Register Summary (working sheet)

8.1.2 Switching of PCM Time Slots to the CFI Interface (data downstream)

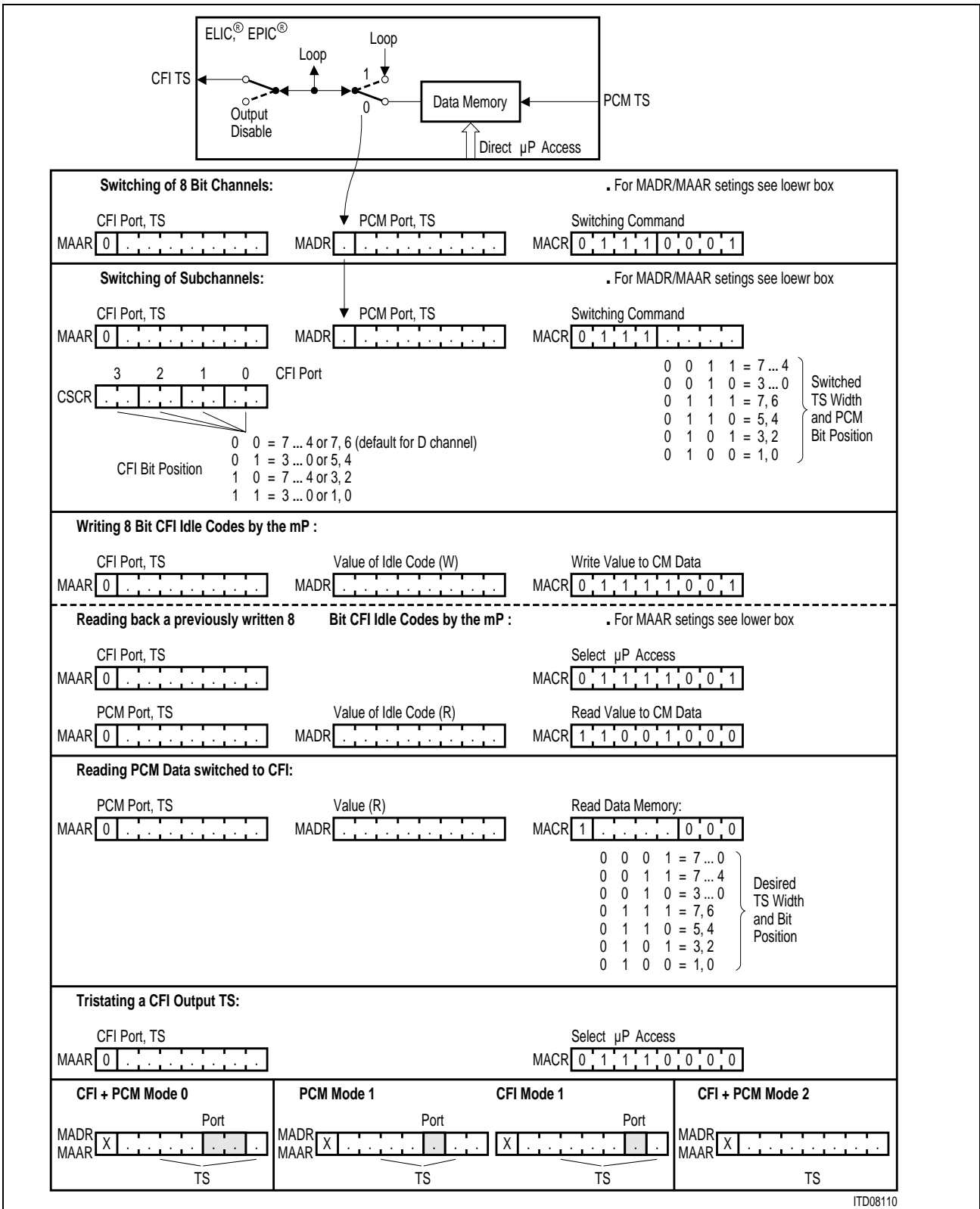

Figure 101
Switching of PCM Time Slots to the CFI Interface (working sheet)

8.1.3 Switching of CFI Time Slots to the PCM Interface (data upstream)

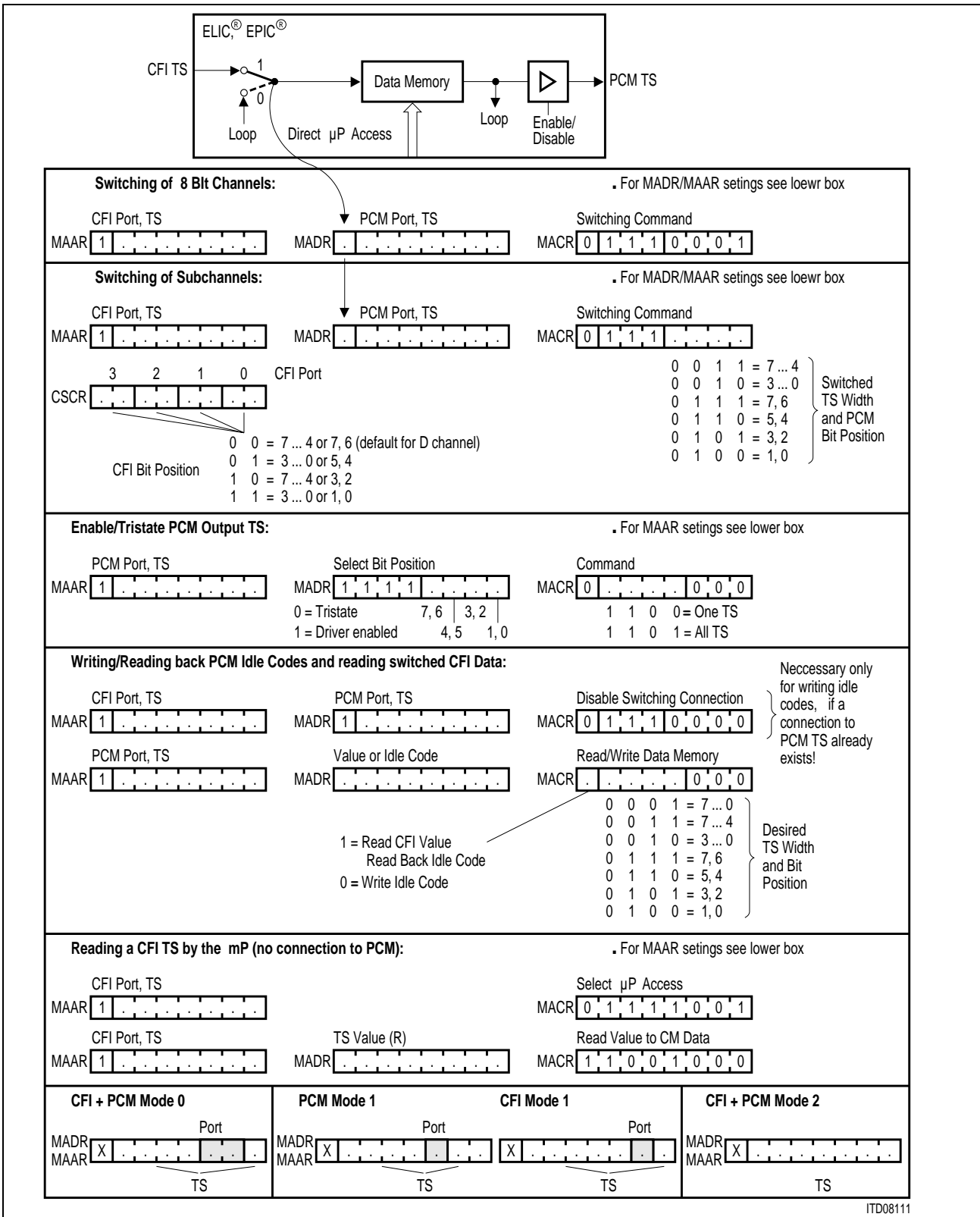

Figure 102 Switching of CFI Time Slots to the PCM Interface (working sheet)

8.1.4 Preparing EPIC®s C/I Channels

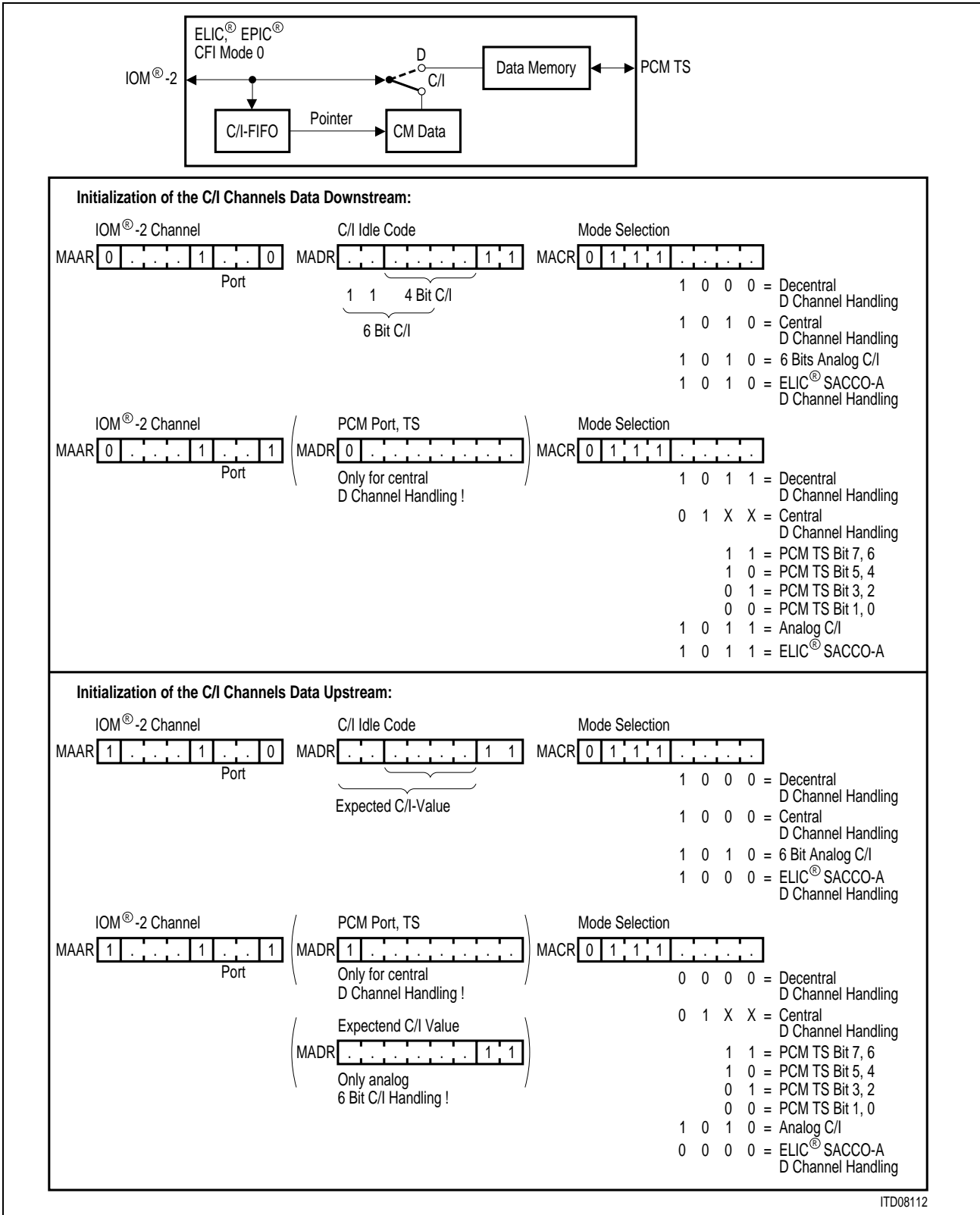

Figure 103
Preparing EPIC®s C/I Channels (working sheet)

8.1.5 Receiving and Transmitting IOM[®]-2 C/I-Codes

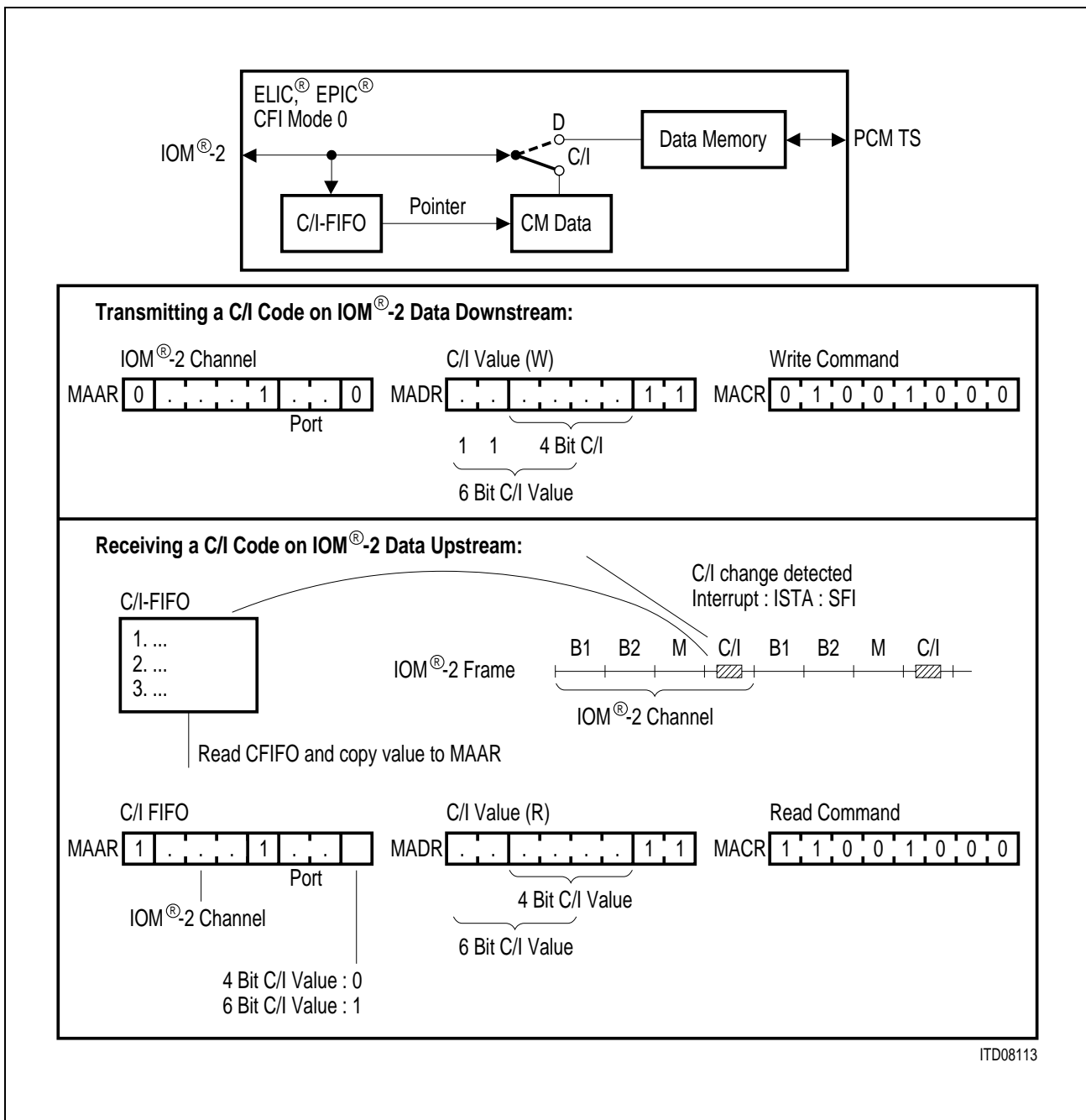

Figure 104
Receiving and Transmitting IOM[®]-2 C/I-Codes (working sheet)

8.2 Development Tools

The SIPB 5000 system can be used as a platform for all development steps. In a later stage it is of course necessary to make a cost optimized design. For this, a subset of the board design can be used. All the wiring diagrams are shipped with the board to speed up this process.

Siemens offers a very convenient menu driven testing and debugging software. The package that is delivered with the user board, allows a direct access to the chip registers using symbolic names. Subsequent access may be written to a file and run as a track file. Example track files are delivered in the package and will be a great help to the user.

8.2.1 SIPB 5000 Mainboard

| Description | Part Number | Ordering Code |
|----------------|-------------|---------------|
| SIPB Mainboard | SIPB 5000 | Q67100-H8647 |

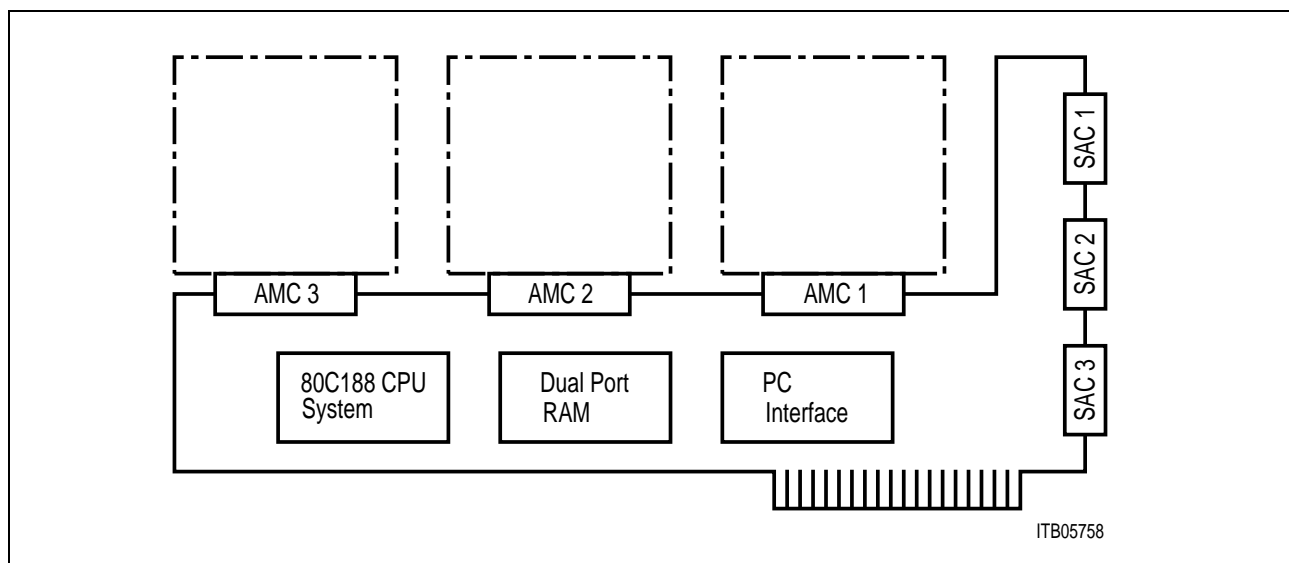
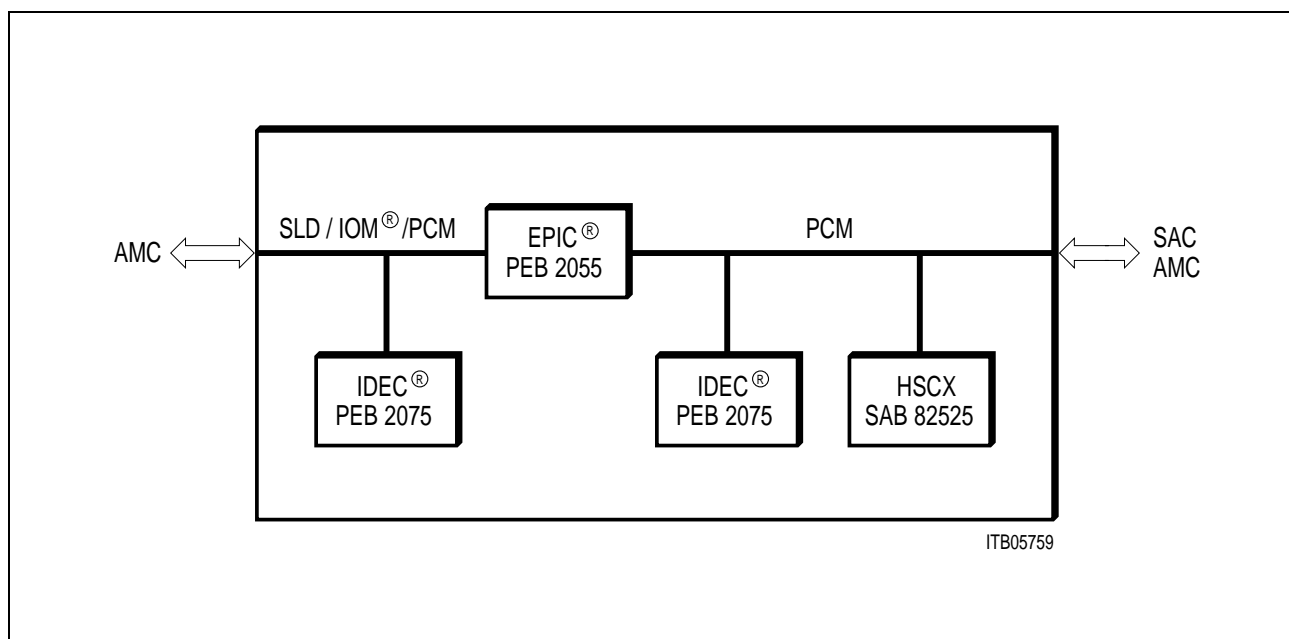

Figure 105
SIPB_5000 Mainboard

The SIPB 5000 Mainboard is the general backbone of the SIPB 5XXX user board system. It is designed as a standard PC interface card, and it contains basically a 80C188 CPU system with 7 interfaces. The interface to the PC is realized both as a Dual Port Ram and as an additional DMA interface. Up to three daughter modules (see dotted blocks) can be added to the Mainboard. They typically carry the components under evaluation. The interfaces which are accessible from the back side of the PC have a connection to the daughter modules as well. This is to allow access to the components under evaluation while the complete board system is hidden inside the PC.

8.2.2 SIPB 5121 IOM[®]-2 Line Card (EPIC[®]/IDEC[®])

| Description | Part Number | Ordering Code |
|------------------------|-------------|---------------|
| IOM-2 Line Card Module | SIPB 5121 | Q67100-H8656 |



**Figure 106
SIPB 5121 IOM[®]-2 Line Card (EPIC[®]/IDEC[®])**

The Line Card Module SIPB 5121 is designed to be used with the ISDN User Board SIPB 5000. It serves as an evaluation tool for various line card architectures using the Enhanced PCM Interface Controller EPIC PEB 2055.

Some possible applications are e.g.:

- Centralized / decentralized D-channel handling of signaling and packet data
- Emulation of a PABX with primary rate module SIPB 7200
- Emulation of a small PABX using two line cards
- Emulation of a digital or analog line card using appropriate layer-1 and/or CODEC filter modules

8.2.3 EPIC® Configurator

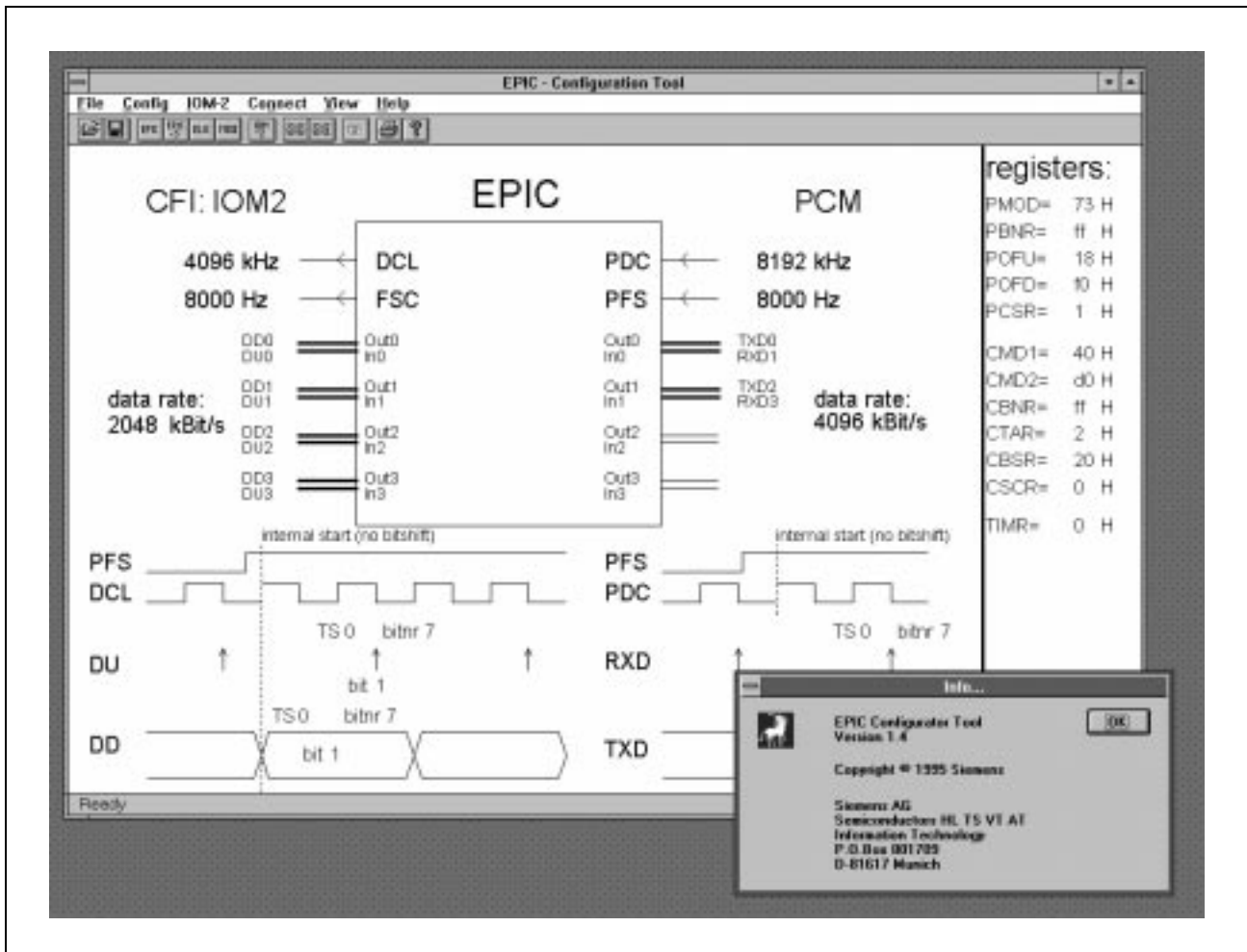

Figure 107
EPIC® Configurator Tool: Screen Shot

The EPIC Configurator is an expert system which helps to initialize the IOM-2 controllers:

- PEB 2015 (MICO)
- PEB 2054 (EPIC-S)
- PEB 2055 (EPIC-1)
- PEB 2055 (ELIC) (only functional units: EPIC, SACCO-A + arbiter)

A menu driven software allows the user to define the system requirements on a functional level.



The Configurator then generates a programming sequence in C code for initializing the EPIC, providing all required register values.

9 Lists**9.1 Glossary**

| | |
|-----------------|---|
| ARCOFI® | Audio ringing codec filter |
| BPF | Bits per PCM frame |
| CFI | Configurable interface |
| CM | Control memory |
| CO | Central office |
| DCL | Data clock |
| EPIC® | Extended PCM interface controller |
| ETSI | European telecommunication standards institute |
| FIFO | First-in first-out (memory) |
| FSC | Frame synchronisation clock |
| HDLC | High-level data link control |
| IC | Integrated circuit |
| ID | Identifier |
| IOM® | ISDN oriented modular |
| ISAC®-P | ISDN subscriber access controller on U-interface |
| OCTAT®-P | Octal transceiver for U _{PN} -interfaces |
| PBC | Peripheral bus controller |
| PBX | Private branch exchange |
| PCM | Pulse code modulation |
| PDC | PCM interface data clock |
| PFS | PCM interface frame synchronisation |
| TE | Terminal equipment |
| U _{PN} | U-interface in private network (PBX) |

Looking for pricing, stock, or lifecycle information?

Click below to explore more details on WIN SOURCE:

-  [View PEF 2054 N V2.1 on WIN SOURCE](#)
-  [Infineon Technologies Information](#)

Optimize Your Supply Chain with WIN SOURCE Solutions

-  Global Sourcing Solution
-  Obsolete Management
-  Cost Control Management
-  Shortage Management
-  Alternative Solution
-  Excess Inventory Management