



PIC16F62X
Data Sheet
FLASH-Based
8-Bit CMOS Microcontroller

Note the following details of the code protection feature on Microchip devices:

- Microchip products meet the specification contained in their particular Microchip Data Sheet.
- Microchip believes that its family of products is one of the most secure families of its kind on the market today, when used in the intended manner and under normal conditions.
- There are dishonest and possibly illegal methods used to breach the code protection feature. All of these methods, to our knowledge, require using the Microchip products in a manner outside the operating specifications contained in Microchip's Data Sheets. Most likely, the person doing so is engaged in theft of intellectual property.
- Microchip is willing to work with the customer who is concerned about the integrity of their code.
- Neither Microchip nor any other semiconductor manufacturer can guarantee the security of their code. Code protection does not mean that we are guaranteeing the product as "unbreakable."

Code protection is constantly evolving. We at Microchip are committed to continuously improving the code protection features of our products.

Information contained in this publication regarding device applications and the like is intended through suggestion only and may be superseded by updates. It is your responsibility to ensure that your application meets with your specifications. No representation or warranty is given and no liability is assumed by Microchip Technology Incorporated with respect to the accuracy or use of such information, or infringement of patents or other intellectual property rights arising from such use or otherwise. Use of Microchip's products as critical components in life support systems is not authorized except with express written approval by Microchip. No licenses are conveyed, implicitly or otherwise, under any intellectual property rights.

Trademarks

The Microchip name and logo, the Microchip logo, KEELOQ, MPLAB, PIC, PICmicro, PICSTART and PRO MATE are registered trademarks of Microchip Technology Incorporated in the U.S.A. and other countries.

FilterLab, microID, MXDEV, MXLAB, PICMASTER, SEEVAL and The Embedded Control Solutions Company are registered trademarks of Microchip Technology Incorporated in the U.S.A.

dsPIC, dsPICDEM.net, ECONOMONITOR, FanSense, FlexROM, fuzzyLAB, In-Circuit Serial Programming, ICSP, ICEPIC, microPort, Migratable Memory, MPASM, MPLIB, MPLINK, MPSIM, PICC, PICDEM, PICDEM.net, rPIC, Select Mode and Total Endurance are trademarks of Microchip Technology Incorporated in the U.S.A. and other countries.

Serialized Quick Turn Programming (SQTP) is a service mark of Microchip Technology Incorporated in the U.S.A.

All other trademarks mentioned herein are property of their respective companies.

© 2003, Microchip Technology Incorporated, Printed in the U.S.A., All Rights Reserved.

 Printed on recycled paper.



Microchip received QS-9000 quality system certification for its worldwide headquarters, design and wafer fabrication facilities in Chandler and Tempe, Arizona in July 1999 and Mountain View, California in March 2002. The Company's quality system processes and procedures are QS-9000 compliant for its PICmicro® 8-bit MCUs, KEELOQ® code hopping devices, Serial EEPROMs, microperipherals, non-volatile memory and analog products. In addition, Microchip's quality system for the design and manufacture of development systems is ISO 9001 certified.

FLASH-Based 8-Bit CMOS Microcontrollers

Devices Included in this Data Sheet:

- PIC16F627
- PIC16F628

Referred to collectively as PIC16F62X

High Performance RISC CPU:

- Only 35 instructions to learn
- All single cycle instructions (200 ns), except for program branches which are two-cycle
- Operating speed:
 - DC - 20 MHz clock input
 - DC - 200 ns instruction cycle

Device	Memory		
	FLASH Program	RAM Data	EEPROM Data
PIC16F627	1024 x 14	224 x 8	128 x 8
PIC16F628	2048 x 14	224 x 8	128 x 8

- Interrupt capability
- 16 special function hardware registers
- 8-level deep hardware stack
- Direct, Indirect and Relative addressing modes

Peripheral Features:

- 16 I/O pins with individual direction control
- High current sink/source for direct LED drive
- Analog comparator module with:
 - Two analog comparators
 - Programmable on-chip voltage reference (VREF) module
 - Programmable input multiplexing from device inputs and internal voltage reference
 - Comparator outputs are externally accessible
- Timer0: 8-bit timer/counter with 8-bit programmable prescaler
- Timer1: 16-bit timer/counter with external crystal/clock capability
- Timer2: 8-bit timer/counter with 8-bit period register, prescaler and postscaler
- Capture, Compare, PWM (CCP) module
 - Capture is 16-bit, max. resolution is 12.5 ns
 - Compare is 16-bit, max. resolution is 200 ns
 - PWM max. resolution is 10-bit

- Universal Synchronous/Asynchronous Receiver/Transmitter USART/SCI
- 16 Bytes of common RAM

Special Microcontroller Features:

- Power-on Reset (POR)
- Power-up Timer (PWRT) and Oscillator Start-up Timer (OST)
- Brown-out Detect (BOD)
- Watchdog Timer (WDT) with its own on-chip RC oscillator for reliable operation
- Multiplexed \overline{MCLR} -pin
- Programmable weak pull-ups on PORTB
- Programmable code protection
- Low voltage programming
- Power saving SLEEP mode
- Selectable oscillator options
 - FLASH configuration bits for oscillator options
 - ER (External Resistor) oscillator
 - Reduced part count
 - Dual speed INTRC
 - Lower current consumption
 - EC External Clock input
 - XT Oscillator mode
 - HS Oscillator mode
 - LP Oscillator mode
- In-circuit Serial Programming™ (via two pins)
- Four user programmable ID locations

CMOS Technology:

- Low power, high speed CMOS FLASH technology
- Fully static design
- Wide operating voltage range
 - PIC16F627 - 3.0V to 5.5V
 - PIC16F628 - 3.0V to 5.5V
 - PIC16LF627 - 2.0V to 5.5V
 - PIC16LF628 - 2.0V to 5.5V
- Commercial, industrial and extended temperature range
- Low power consumption
 - < 2.0 mA @ 5.0V, 4.0 MHz
 - 15 μ A typical @ 3.0V, 32 kHz
 - < 1.0 μ A typical standby current @ 3.0V

PIC16F62X

Pin Diagrams

PDIP, SOIC

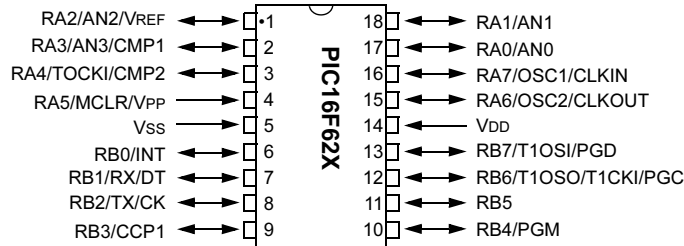

SSOP

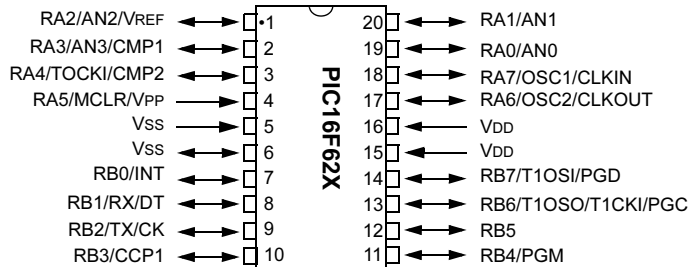

Device Differences

Device	Voltage Range	Oscillator	Process Technology (Microns)
PIC16F627	3.0 - 5.5	(Note 1)	0.7
PIC16F628	3.0 - 5.5	(Note 1)	0.7
PIC16LF627	2.0 - 5.5	(Note 1)	0.7
PIC16LF628	2.0 - 5.5	(Note 1)	0.7

Note 1: If you change from this device to another device, please verify oscillator characteristics in your application.

Table of Contents

1.0	General Description.....	5
2.0	PIC16F62X Device Varieties.....	7
3.0	Architectural Overview.....	9
4.0	Memory Organization.....	15
5.0	I/O Ports.....	29
6.0	Timer0 Module.....	43
7.0	Timer1 Module.....	46
8.0	Timer2 Module.....	50
9.0	Comparator Module.....	53
10.0	Voltage Reference Module.....	59
11.0	Capture/Compare/PWM (CCP) Module.....	61
12.0	Universal Synchronous/ Asynchronous Receiver/ Transmitter (USART) Module.....	67
13.0	Data EEPROM Memory.....	87
14.0	Special Features of the CPU.....	91
15.0	Instruction Set Summary.....	107
16.0	Development Support.....	121
17.0	Electrical Specifications.....	127
18.0	DC and AC Characteristics Graphs and Tables.....	143
19.0	Packaging Information.....	157

TO OUR VALUED CUSTOMERS

It is our intention to provide our valued customers with the best documentation possible to ensure successful use of your Microchip products. To this end, we will continue to improve our publications to better suit your needs. Our publications will be refined and enhanced as new volumes and updates are introduced.

If you have any questions or comments regarding this publication, please contact the Marketing Communications Department via E-mail at docerrors@mail.microchip.com or fax the **Reader Response Form** in the back of this data sheet to (480) 792-4150. We welcome your feedback.

Most Current Data Sheet

To obtain the most up-to-date version of this data sheet, please register at our Worldwide Web site at:

<http://www.microchip.com>

You can determine the version of a data sheet by examining its literature number found on the bottom outside corner of any page. The last character of the literature number is the version number, (e.g., DS30000A is version A of document DS30000).

Errata

An errata sheet, describing minor operational differences from the data sheet and recommended workarounds, may exist for current devices. As device/documentation issues become known to us, we will publish an errata sheet. The errata will specify the revision of silicon and revision of document to which it applies.

To determine if an errata sheet exists for a particular device, please check with one of the following:

- Microchip's Worldwide Web site; <http://www.microchip.com>
- Your local Microchip sales office (see last page)
- The Microchip Corporate Literature Center; U.S. FAX: (480) 792-7277

When contacting a sales office or the literature center, please specify which device, revision of silicon and data sheet (include literature number) you are using.

Customer Notification System

Register on our web site at www.microchip.com/cn to receive the most current information on all of our products.

PIC16F62X

NOTES:

1.0 PIC16F62X DEVICE VARIETIES

A variety of frequency ranges and packaging options are available. Depending on application and production requirements, the proper device option can be selected using the information in the PIC16F62X Product Identification System section (Page 167) at the end of this data sheet. When placing orders, please use this page of the data sheet to specify the correct part number.

1.1 FLASH Devices

FLASH devices can be erased and reprogrammed electrically. This allows the same device to be used for prototype development, pilot programs and production.

A further advantage of the electrically-erasable FLASH is that it can be erased and reprogrammed in-circuit, or by device programmers, such as Microchip's PICSTART[®] Plus, or PRO MATE[®] II programmers.

1.2 Quick-Turnaround Production (QTP) Devices

Microchip offers a QTP Programming Service for factory production orders. This service is made available for users who chose not to program a medium-to-high quantity of units and whose code patterns have stabilized. The devices are standard FLASH devices but with all program locations and configuration options already programmed by the factory. Certain code and prototype verification procedures apply before production shipments are available. Please contact your Microchip Technology sales office for more details.

1.3 Serialized Quick-Turnaround Production (SQTPsm) Devices

Microchip offers a unique programming service where a few user-defined locations in each device are programmed with different serial numbers. The serial numbers may be random, pseudo-random or sequential.

Serial programming allows each device to have a unique number which can serve as an entry-code, password or ID number.

PIC16F62X

NOTES:

2.0 ARCHITECTURAL OVERVIEW

The high performance of the PIC16F62X family can be attributed to a number of architectural features commonly found in RISC microprocessors. To begin with, the PIC16F62X uses a Harvard architecture, in which, program and data are accessed from separate memories using separate buses. This improves bandwidth over traditional Von Neumann architecture where program and data are fetched from the same memory. Separating program and data memory further allows instructions to be sized differently than 8-bit wide data word. Instruction opcodes are 14-bits wide making it possible to have all single-word instructions. A 14-bit wide program memory access bus fetches a 14-bit instruction in a single cycle. A two-stage pipeline overlaps fetch and execution of instructions. Consequently, all instructions (35) execute in a single cycle (200 ns @ 20 MHz) except for program branches.

The Table below lists program memory (FLASH, Data and EEPROM).

TABLE 2-1: DEVICE DESCRIPTION

Device	Memory		
	FLASH Program	RAM Data	EEPROM Data
PIC16F627	1024 x 14	224 x 8	128 x 8
PIC16F628	2048 x 14	224 x 8	128 x 8
PIC16LF627	1024 x 14	224 x 8	128 x 8
PIC16LF628	2048 x 14	224 x 8	128 x 8

The PIC16F62X can directly or indirectly address its register files or data memory. All Special Function registers, including the program counter, are mapped in the data memory. The PIC16F62X have an orthogonal (symmetrical) instruction set that makes it possible to carry out any operation, on any register, using any Addressing mode. This symmetrical nature, and lack of 'special optimal situations' make programming with the PIC16F62X simple yet efficient. In addition, the learning curve is reduced significantly.

The PIC16F62X devices contain an 8-bit ALU and working register. The ALU is a general purpose arithmetic unit. It performs arithmetic and Boolean functions between data in the working register and any register file.

The ALU is 8-bit wide and capable of addition, subtraction, shift and logical operations. Unless otherwise mentioned, arithmetic operations are two's complement in nature. In two-operand instructions, typically one operand is the working register (W register). The other operand is a file register or an immediate constant. In single operand instructions, the operand is either the W register or a file register.

The W register is an 8-bit working register used for ALU operations. It is not an addressable register.

Depending on the instruction executed, the ALU may affect the values of the Carry (C), Digit Carry (DC), and Zero (Z) bits in the STATUS register. The C and DC bits operate as a Borrow and Digit Borrow out bit, respectively, bit in subtraction. See the SUBLW and SUBWF instructions for examples.

A simplified block diagram is shown in Figure 2-1, and a description of the device pins in Table 2-1.

Two types of data memory are provided on the PIC16F62X devices. Non-volatile EEPROM data memory is provided for long term storage of data such as calibration values, lookup table data, and any other data which may require periodic updating in the field. This data is not lost when power is removed. The other data memory provided is regular RAM data memory. Regular RAM data memory is provided for temporary storage of data during normal operation. It is lost when power is removed.

PIC16F62X

FIGURE 2-1: BLOCK DIAGRAM

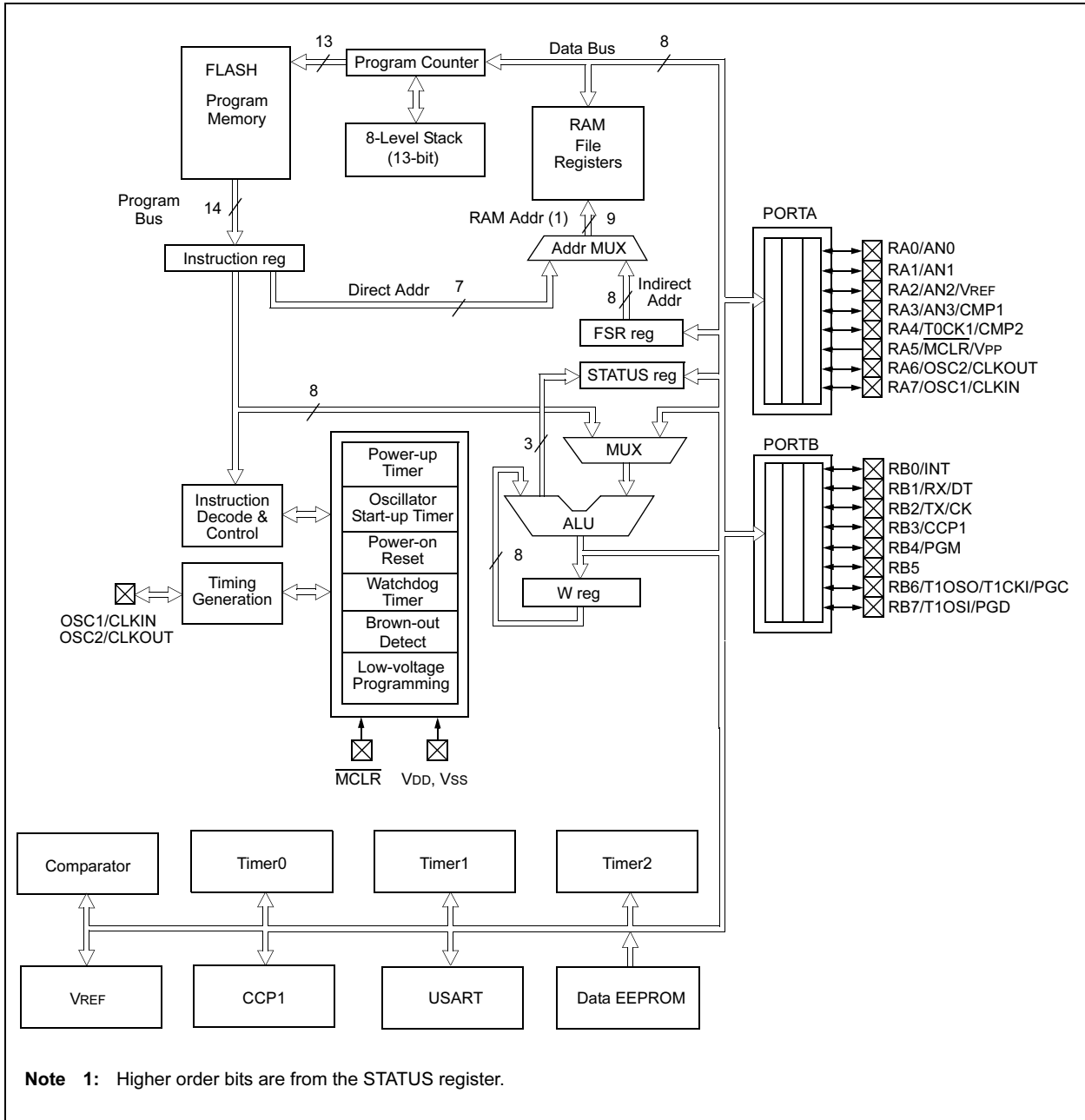

TABLE 2-1: PIC16F62X PINOUT DESCRIPTION

Name	Function	Input Type	Output Type	Description
RA0/AN0	RA0	ST	CMOS	Bi-directional I/O port
	AN0	AN	—	Analog comparator input
RA1/AN1	RA1	ST	CMOS	Bi-directional I/O port
	AN1	AN	—	Analog comparator input
RA2/AN2/VREF	RA2	ST	CMOS	Bi-directional I/O port
	AN2	AN	—	Analog comparator input
	VREF	—	AN	VREF output
RA3/AN3/CMP1	RA3	ST	CMOS	Bi-directional I/O port
	AN3	AN	—	Analog comparator input
	CMP1	—	CMOS	Comparator 1 output
RA4/T0CKI/CMP2	RA4	ST	OD	Bi-directional I/O port
	T0CKI	ST	—	Timer0 clock input
	CMP2	—	OD	Comparator 2 output
RA5/MCLR/VPP	RA5	ST	—	Input port
	MCLR	ST	—	Master clear
	VPP	—	—	Programming voltage input. When configured as MCLR, this pin is an active low RESET to the device. Voltage on MCLR/VPP must not exceed VDD during normal device operation.
RA6/OSC2/CLKOUT	RA6	ST	CMOS	Bi-directional I/O port
	OSC2	XTAL	—	Oscillator crystal output. Connects to crystal or resonator in Crystal Oscillator mode.
	CLKOUT	—	CMOS	In ER/INTRC mode, OSC2 pin can output CLKOUT, which has 1/4 the frequency of OSC1
RA7/OSC1/CLKIN	RA7	ST	CMOS	Bi-directional I/O port
	OSC1	XTAL	—	Oscillator crystal input
	CLKIN	ST	—	External clock source input. ER biasing pin.
RB0/INT	RB0	TTL	CMOS	Bi-directional I/O port. Can be software programmed for internal weak pull-up.
	INT	ST	—	External interrupt.
RB1/RX/DT	RB1	TTL	CMOS	Bi-directional I/O port. Can be software programmed for internal weak pull-up.
	RX	ST	—	USART receive pin
	DT	ST	CMOS	Synchronous data I/O.
RB2/TX/CK	RB2	TTL	CMOS	Bi-directional I/O port.
	TX	—	CMOS	USART transmit pin
	CK	ST	CMOS	Synchronous clock I/O. Can be software programmed for internal weak pull-up.
RB3/CCP1	RB3	TTL	CMOS	Bi-directional I/O port. Can be software programmed for internal weak pull-up.
	CCP1	ST	CMOS	Capture/Compare/PWM I/O

Legend: O = Output
 — = Not used
 TTL = TTL Input

CMOS = CMOS Output
 I = Input
 OD = Open Drain Output

P = Power
 ST = Schmitt Trigger Input
 AN = Analog

PIC16F62X

TABLE 2-1: PIC16F62X PINOUT DESCRIPTION (CONTINUED)

Name	Function	Input Type	Output Type	Description
RB4/PGM	RB4	TTL	CMOS	Bi-directional I/O port. Can be software programmed for internal weak pull-up.
	PGM	ST	—	Low voltage programming input pin. Interrupt-on-pin change. When low voltage programming is enabled, the interrupt-on-pin change and weak pull-up resistor are disabled.
RB5	RB5	TTL	CMOS	Bi-directional I/O port. Interrupt-on-pin change. Can be software programmed for internal weak pull-up.
RB6/T1OSO/T1CKI/PGC	RB6	TTL	CMOS	Bi-directional I/O port. Interrupt-on-pin change. Can be software programmed for internal weak pull-up.
	T1OSO	—	XTAL	Timer1 oscillator output.
	T1CKI	ST	—	Timer1 clock input.
	PGC	ST	—	ICSP™ Programming Clock.
RB7/T1OSI/PGD	RB7	TTL	CMOS	Bi-directional I/O port. Interrupt-on-pin change. Can be software programmed for internal weak pull-up.
	T1OSI	XTAL	—	Timer1 oscillator input. Wake-up from SLEEP on pin change. Can be software programmed for internal weak pull-up.
	PGD	ST	CMOS	ICSP Data I/O
VSS	VSS	Power	—	Ground reference for logic and I/O pins
VDD	VDD	Power	—	Positive supply for logic and I/O pins

Legend: O = Output CMOS = CMOS Output P = Power
 — = Not used I = Input ST = Schmitt Trigger Input
 TTL = TTL Input OD = Open Drain Output AN = Analog

2.1 Clocking Scheme/Instruction Cycle

The clock input (OSC1/CLKIN/RA7 pin) is internally divided by four to generate four non-overlapping quadrature clocks namely Q1, Q2, Q3 and Q4. Internally, the program counter (PC) is incremented every Q1, the instruction is fetched from the program memory and latched into the instruction register in Q4. The instruction is decoded and executed during the following Q1 through Q4. The clocks and instruction execution flow is shown in Figure 2-2.

2.2 Instruction Flow/Pipelining

An "Instruction Cycle" consists of four Q cycles (Q1, Q2, Q3 and Q4). The instruction fetch and execute are pipelined such that fetch takes one instruction cycle while decode and execute takes another instruction cycle. However, due to the pipelining, each instruction effectively executes in one cycle. If an instruction causes the program counter to change, (e.g., GOTO) then two cycles are required to complete the instruction (Example 2-1).

A fetch cycle begins with the program counter (PC) incrementing in Q1.

In the execution cycle, the fetched instruction is latched into the "Instruction Register (IR)" in cycle Q1. This instruction is then decoded and executed during the Q2, Q3, and Q4 cycles. Data memory is read during Q2 (operand read) and written during Q4 (destination write).

FIGURE 2-2: CLOCK/INSTRUCTION CYCLE

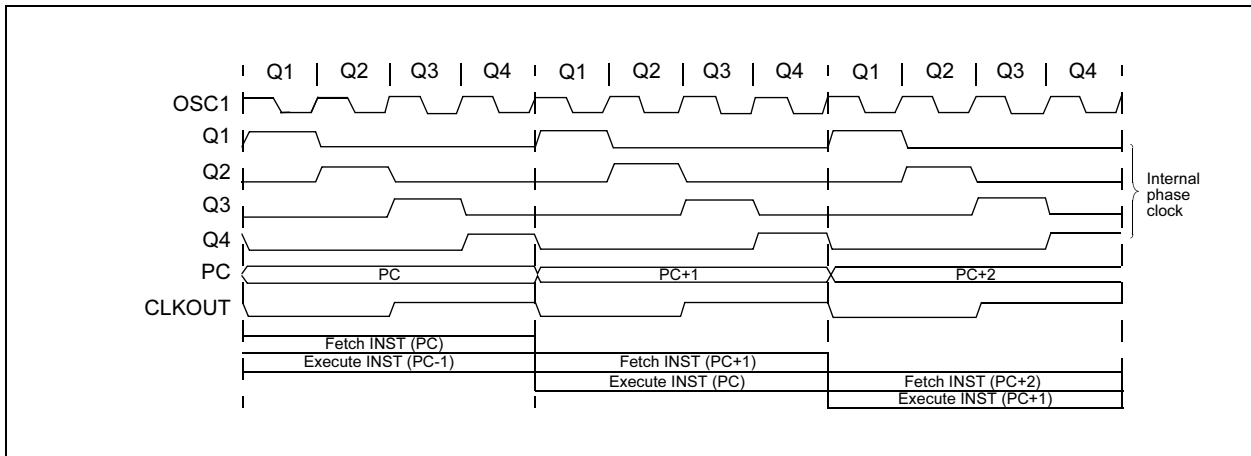

EXAMPLE 2-1: INSTRUCTION PIPELINE FLOW

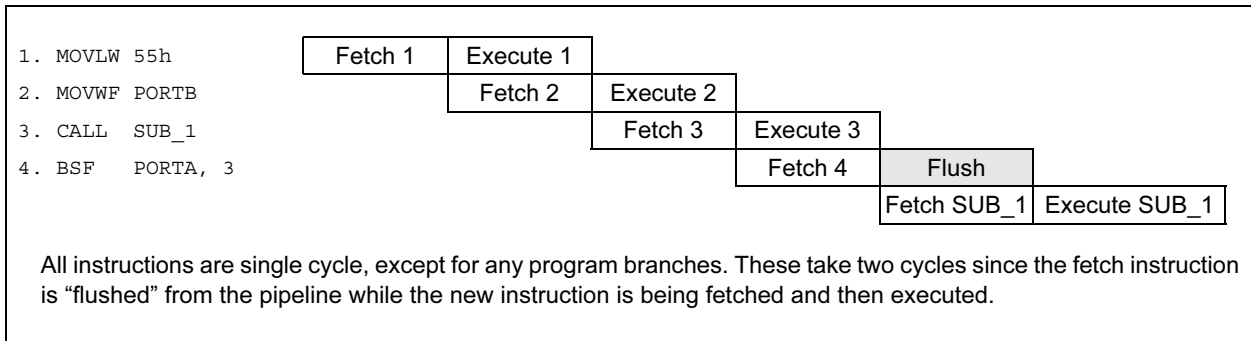

PIC16F62X

NOTES:

3.0 MEMORY ORGANIZATION

3.1 Program Memory Organization

The PIC16F62X has a 13-bit program counter capable of addressing an 8K x 14 program memory space. Only the first 1K x 14 (0000h - 03FFh) for the PIC16F627 and 2K x 14 (0000h - 07FFh) for the PIC16F628 are physically implemented. Accessing a location above these boundaries will cause a wrap-around within the first 1K x 14 space (PIC16F627) or 2K x 14 space (PIC16F628). The RESET vector is at 0000h and the interrupt vector is at 0004h (Figure 3-1).

FIGURE 3-1: PROGRAM MEMORY MAP AND STACK

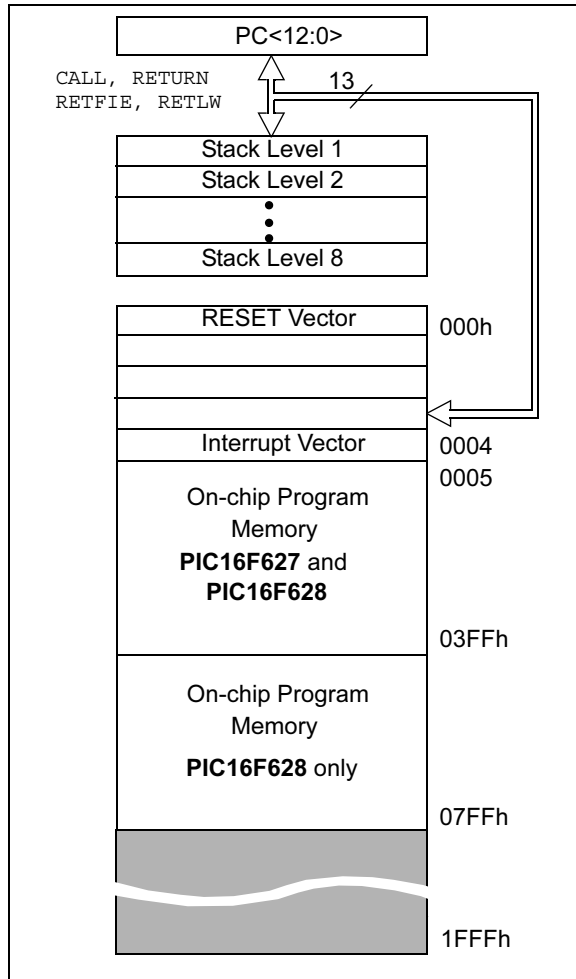

3.2 Data Memory Organization

The data memory (Figure 3-2) is partitioned into four banks, which contain the general purpose registers and the Special Function Registers (SFR). The SFR's are located in the first 32 locations of each Bank. Register locations 20-7Fh, A0h-FFh, 120h-14Fh, 170h-17Fh and 1F0h-1FFh are general purpose registers implemented as static RAM.

The Table below lists how to access the four banks of registers:

	RP1	RP0
Bank0	0	0
Bank1	0	1
Bank2	1	0
Bank3	1	1

Addresses F0h-FFh, 170h-17Fh and 1F0h-1FFh are implemented as common RAM and mapped back to addresses 70h-7Fh.

3.2.1 GENERAL PURPOSE REGISTER FILE

The register file is organized as 224 x 8 in the PIC16F62X. Each is accessed either directly or indirectly through the File Select Register FSR (See Section 3.4).

PIC16F62X

FIGURE 3-2: DATA MEMORY MAP OF THE PIC16F627 AND PIC16F628

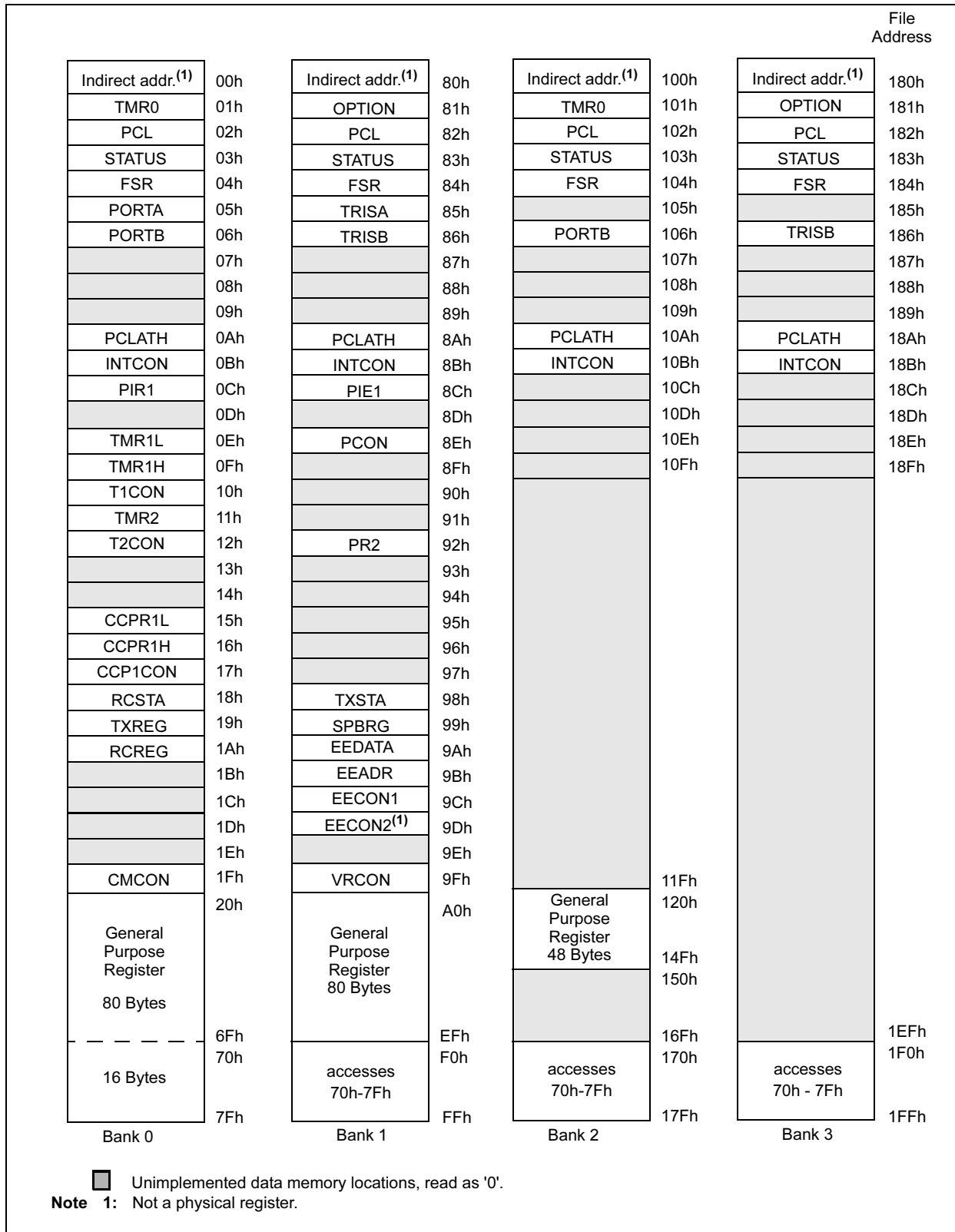

3.2.2 SPECIAL FUNCTION REGISTERS

The SFRs are registers used by the CPU and Peripheral functions for controlling the desired operation of the device (Table 3-1). These registers are static RAM.

The special registers can be classified into two sets (core and peripheral). The SFRs associated with the “core” functions are described in this section. Those related to the operation of the peripheral features are described in the section of that peripheral feature.

TABLE 3-1: SPECIAL REGISTERS SUMMARY BANK 0

Address	Name	Bit 7	Bit 6	Bit 5	Bit 4	Bit 3	Bit 2	Bit 1	Bit 0	Value on POR Reset ⁽¹⁾	Details on Page	
Bank 0												
00h	INDF	Addressing this location uses contents of FSR to address data memory (not a physical register)									xxxx xxxx	25
01h	TMR0	Timer0 Module's Register									xxxx xxxx	43
02h	PCL	Program Counter's (PC) Least Significant Byte									0000 0000	13
03h	STATUS	IRP	RP1	RP0	\overline{TO}	\overline{PD}	Z	DC	C	0001 1xxxx	19	
04h	FSR	Indirect data memory address pointer									xxxx xxxx	25
05h	PORTA	RA7	RA6	RA5	RA4	RA3	RA2	RA1	RA0	xxxx 0000	29	
06h	PORTB	RB7	RB6	RB5	RB4	RB3	RB2	RB1	RB0	xxxx xxxx	34	
07h	—	Unimplemented									—	—
08h	—	Unimplemented									—	—
09h	—	Unimplemented									—	—
0Ah	PCLATH	—	—	—	Write buffer for upper 5 bits of program counter					---	0000	25
0Bh	INTCON	GIE	PEIE	TOIE	INTE	RBIE	TOIF	INTF	RBIF	0000 000x	21	
0Ch	PIR1	EEIF	CMIF	RCIF	TXIF	—	CCP1IF	TMR2IF	TMR1IF	0000 -000	23	
0Dh	—	Unimplemented									—	—
0Eh	TMR1L	Holding register for the Least Significant Byte of the 16-bit TMR1									xxxx xxxx	46
0Fh	TMR1H	Holding register for the Most Significant Byte of the 16-bit TMR1									xxxx xxxx	46
10h	T1CON	—	—	T1CKPS1	T1CKPS0	T1OSCEN	$\overline{T1SYNC}$	TMR1CS	TMR1ON	--00 0000	46	
11h	TMR2	TMR2 module's register									0000 0000	50
12h	T2CON	—	TOUTPS3	TOUTPS2	TOUTPS1	TOUTPS0	TMR2ON	T2CKPS1	T2CKPS0	-000 0000	50	
13h	—	Unimplemented									—	—
14h	—	Unimplemented									—	—
15h	CCPR1L	Capture/Compare/PWM register (LSB)									xxxx xxxx	61
16h	CCPR1H	Capture/Compare/PWM register (MSB)									xxxx xxxx	61
17h	CCP1CON	—	—	CCP1X	CCP1Y	CCP1M3	CCP1M2	CCP1M1	CCP1M0	--00 0000	61	
18h	RCSTA	SPEN	RX9	SREN	CREN	ADEN	FERR	OERR	RX9D	0000 -00x	67	
19h	TXREG	USART Transmit data register									0000 0000	74
1Ah	RCREG	USART Receive data register									0000 0000	77
1Bh	—	Unimplemented									—	—
1Ch	—	Unimplemented									—	—
1Dh	—	Unimplemented									—	—
1Eh	—	Unimplemented									—	—
1Fh	CMCON	C2OUT	C1OUT	C2INV	C1INV	CIS	CM2	CM1	CM0	0000 0000	53	

Legend: — = Unimplemented locations read as '0', u = unchanged, x = unknown, q = value depends on condition, shaded = unimplemented

Note 1: For the Initialization Condition for Registers Tables, refer to Table 14-7 and Table 14-8 on page 98.

PIC16F62X

TABLE 3-2: SPECIAL FUNCTION REGISTERS SUMMARY BANK 1

Address	Name	Bit 7	Bit 6	Bit 5	Bit 4	Bit 3	Bit 2	Bit 1	Bit 0	Value on POR Reset ⁽¹⁾	Details on Page	
Bank 1												
80h	INDF	Addressing this location uses contents of FSR to address data memory (not a physical register)								xxxx xxxx	25	
81h	OPTION	RBPV	INTEDG	T0CS	T0SE	PSA	PS2	PS1	PS0	1111 1111	20	
82h	PCL	Program Counter's (PC) Least Significant Byte								0000 0000	25	
83h	STATUS	IRP	RP1	RP0	T0	PD	Z	DC	C	0001 1xxx	19	
84h	FSR	Indirect data memory address pointer								xxxx xxxx	25	
85h	TRISA	TRISA7	TRISA6	TRISA5	TRISA4	TRISA3	TRISA2	TRISA1	TRISA0	1111 1111	29	
86h	TRISB	TRISB7	TRISB6	TRISB5	TRISB4	TRISB3	TRISB2	TRISB1	TRISB0	1111 1111	34	
87h	—	Unimplemented								—	—	
88h	—	Unimplemented								—	—	
89h	—	Unimplemented								—	—	
8Ah	PCLATH	—	—	—	Write buffer for upper 5 bits of program counter					---0 0000	25	
8Bh	INTCON	GIE	PEIE	T0IE	INTE	RBIE	T0IF	INTF	RBIF	0000 000x	21	
8Ch	PIE1	EEIE	CMIE	RCIE	TXIE	—	CCP1IE	TMR2IE	TMR1IE	0000 -000	22	
8Dh	—	Unimplemented								—	—	
8Eh	PCON	—	—	—	—	OSCF	—	POR	BOD	---- 1-0x	24	
8Fh	—	Unimplemented								—	—	
90h	—	Unimplemented								—	—	
91h	—	Unimplemented								—	—	
92h	PR2	Timer2 Period Register								1111 1111	50	
93h	—	Unimplemented								—	—	
94h	—	Unimplemented								—	—	
95h	—	Unimplemented								—	—	
96h	—	Unimplemented								—	—	
97h	—	Unimplemented								—	—	
98h	TXSTA	CSRC	TX9	TXEN	SYNC	—	BRGH	TRMT	TX9D	0000 -010	69	
99h	SPBRG	Baud Rate Generator Register								0000 0000	69	
9Ah	EEDATA	EEPROM data register								xxxx xxxx	87	
9Bh	EEADR	—	EEPROM address register								xxxx xxxx	87
9Ch	EECON1	—	—	—	—	WRERR	WREN	WR	RD	---- x000	87	
9Dh	EECON2	EEPROM control register 2 (not a physical register)								-----	87	
9Eh	—	Unimplemented								—	—	
9Fh	VRCON	VREN	VROE	VRR	—	VR3	VR2	VR1	VR0	000- 0000	59	

Legend: — = Unimplemented locations read as '0', u = unchanged, x = unknown, q = value depends on condition, shaded = unimplemented

Note 1: For the Initialization Condition for Registers Tables, refer to Table 14-7 and Table 14-8 on page 98.

TABLE 3-3: SPECIAL FUNCTION REGISTERS SUMMARY BANK 2

Address	Name	Bit 7	Bit 6	Bit 5	Bit 4	Bit 3	Bit 2	Bit 1	Bit 0	Value on POR Reset ⁽¹⁾	Details on Page
Bank 2											
100h	INDF	Addressing this location uses contents of FSR to address data memory (not a physical register)								xxxx xxxx	25
101h	TMR0	RBP \bar{U}	INTEDG	T0CS	T0SE	PSA	PS2	PS1	PS0	1111 1111	43
102h	PCL	Program Counter's (PC) Least Significant Byte								0000 0000	25
103h	STATUS	IRP	RP1	RP0	$\bar{T}O$	$\bar{P}D$	Z	DC	C	0001 1xxx	19
104h	FSR	Indirect data memory address pointer								xxxx xxxx	25
105h	—	Unimplemented								—	—
106h	PORTB	RB7	RB6	RB5	RB4	RB3	RB2	RB1	RB0	xxxx xxxx	34
107h	—	Unimplemented								—	—
108h	—	Unimplemented								—	—
109h	—	Unimplemented								—	—
10Ah	PCLATH	—	—	—	Write buffer for upper 5 bits of program counter					---0 0000	25
10Bh	INTCON	GIE	PEIE	T0IE	INTE	RBIE	TOIF	INTF	RBIF	0000 000x	21
10Ch	—	Unimplemented								—	—
10Dh	—	Unimplemented								—	—
10Eh	—	Unimplemented								—	—
10Fh	—	Unimplemented								—	—
110h	—	Unimplemented								—	—
111h	—	Unimplemented								—	—
112h	—	Unimplemented								—	—
113h	—	Unimplemented								—	—
114h	—	Unimplemented								—	—
115h	—	Unimplemented								—	—
116h	—	Unimplemented								—	—
117h	—	Unimplemented								—	—
118h	—	Unimplemented								—	—
119h	—	Unimplemented								—	—
11Ah	—	Unimplemented								—	—
11Bh	—	Unimplemented								—	—
11Ch	—	Unimplemented								—	—
11Dh	—	Unimplemented								—	—
11Eh	—	Unimplemented								—	—
11Fh	—	Unimplemented								—	—

Legend: — = Unimplemented locations read as '0', u = unchanged, x = unknown, q = value depends on condition, shaded = unimplemented.

Note 1: For the Initialization Condition for Registers Tables, refer to Table 14-7 and Table 14-8 on page 98.

PIC16F62X

TABLE 3-4: SPECIAL FUNCTION REGISTERS SUMMARY BANK 3

Address	Name	Bit 7	Bit 6	Bit 5	Bit 4	Bit 3	Bit 2	Bit 1	Bit 0	Value on POR Reset ⁽¹⁾	Details on Page
Bank 3											
180h	INDF	Addressing this location uses contents of FSR to address data memory (not a physical register)								xxxxx xxxxx	25
181h	OPTION	RBP \bar{U}	INTEDG	T0CS	T0SE	PSA	PS2	PS1	PS0	1111 1111	20
182h	PCL	Program Counter's (PC) Least Significant Byte								0000 0000	25
183h	STATUS	IRP	RP1	RP0	$\bar{T}O$	$\bar{P}D$	Z	DC	C	0001 1xxxx	19
184h	FSR	Indirect data memory address pointer								xxxxx xxxxx	25
185h	—	Unimplemented								—	—
186h	TRISB	TRISB7	TRISB6	TRISB5	TRISB4	TRISB3	TRISB2	TRISB1	TRISB0	1111 1111	34
187h	—	Unimplemented								—	—
188h	—	Unimplemented								—	—
189h	—	Unimplemented								—	—
18Ah	PCLATH	—	—	—	Write buffer for upper 5 bits of program counter					---0 0000	25
18Bh	INTCON	GIE	PEIE	T0IE	INTE	RBIE	T0IF	INTF	RBIF	0000 000x	21
18Ch	—	Unimplemented								—	—
18Dh	—	Unimplemented								—	—
18Eh	—	Unimplemented								—	—
18Fh	—	Unimplemented								—	—
190h	—	Unimplemented								—	—
191h	—	Unimplemented								—	—
192h	—	Unimplemented								—	—
193h	—	Unimplemented								—	—
194h	—	Unimplemented								—	—
195h	—	Unimplemented								—	—
196h	—	Unimplemented								—	—
197h	—	Unimplemented								—	—
198h	—	Unimplemented								—	—
199h	—	Unimplemented								—	—
19Ah	—	Unimplemented								—	—
19Bh	—	Unimplemented								—	—
19Ch	—	Unimplemented								—	—
19Dh	—	Unimplemented								—	—
19Eh	—	Unimplemented								—	—
19Fh	—	Unimplemented								—	—

Legend: — = Unimplemented locations read as '0', u = unchanged, x = unknown, q = value depends on condition, shaded = unimplemented

Note 1: For the Initialization Condition for Registers Tables, refer to Table 14-7 and Table 14-8 on page 98.

3.2.2.1 STATUS Register

The STATUS register, shown in Register 3-1, contains the arithmetic status of the ALU, the RESET status and the bank select bits for data memory (SRAM).

The STATUS register can be the destination for any instruction, like any other register. If the STATUS register is the destination for an instruction that affects the Z, DC or C bits, then the write to these three bits is disabled. These bits are set or cleared according to the device logic. Furthermore, the $\overline{\text{TO}}$ and $\overline{\text{PD}}$ bits are not writable. Therefore, the result of an instruction with the STATUS register as destination may be different than intended.

For example, `CLRF STATUS` will clear the upper-three bits and set the Z bit. This leaves the STATUS register as `000uu1uu` (where u = unchanged).

It is recommended, therefore, that only `BCF`, `BSF`, `SWAPF` and `MOVWF` instructions are used to alter the STATUS register because these instructions do not affect any STATUS bit. For other instructions, not affecting any STATUS bits, see the "Instruction Set Summary".

Note 1: The C and DC bits operate as a Borrow and Digit Borrow out bit, respectively, in subtraction. See the `SUBLW` and `SUBWF` instructions for examples.

REGISTER 3-1: STATUS REGISTER (ADDRESS: 03h, 83h, 103h, 183h)

	R/W-0	R/W-0	R/W-0	R-1	R-1	R/W-x	R/W-x	R/W-x	
	IRP	RP1	RP0	$\overline{\text{TO}}$	$\overline{\text{PD}}$	Z	DC	C	
	bit 7						bit 0		

- bit 7 **IRP:** Register Bank Select bit (used for indirect addressing)
 1 = Bank 2, 3 (100h - 1FFh)
 0 = Bank 0, 1 (00h - FFh)
- bit 6-5 **RP1:RP0:** Register Bank Select bits (used for direct addressing)
 00 = Bank 0 (00h - 7Fh)
 01 = Bank 1 (80h - FFh)
 10 = Bank 2 (100h - 17Fh)
 11 = Bank 3 (180h - 1FFh)
- bit 4 **$\overline{\text{TO}}$:** Timeout bit
 1 = After power-up, `CLRWDT` instruction, or `SLEEP` instruction
 0 = A WDT timeout occurred
- bit 3 **$\overline{\text{PD}}$:** Power-down bit
 1 = After power-up or by the `CLRWDT` instruction
 0 = By execution of the `SLEEP` instruction
- bit 2 **Z:** Zero bit
 1 = The result of an arithmetic or logic operation is zero
 0 = The result of an arithmetic or logic operation is not zero
- bit 1 **DC:** Digit carry/borrow bit (`ADDWF`, `ADDLW`, `SUBLW`, `SUBWF` instructions) (for borrow the polarity is reversed)
 1 = A carry-out from the 4th low order bit of the result occurred
 0 = No carry-out from the 4th low order bit of the result
- bit 0 **C:** Carry/borrow bit (`ADDWF`, `ADDLW`, `SUBLW`, `SUBWF` instructions)
 1 = A carry-out from the Most Significant bit of the result occurred
 0 = No carry-out from the Most Significant bit of the result occurred

Note 1: For borrow the polarity is reversed. A subtraction is executed by adding the two's complement of the second operand. For rotate (`RRF`, `RLF`) instructions, this bit is loaded with either the high or low order bit of the source register.

Legend:

R = Readable bit	W = Writable bit	U = Unimplemented bit, read as '0'
-n = Value at POR	'1' = Bit is set	'0' = Bit is cleared x = Bit is unknown

PIC16F62X

3.2.2.2 OPTION Register

The OPTION register is a readable and writable register which contains various control bits to configure the TMR0/WDT prescaler, the external RB0/INT interrupt, TMR0, and the weak pull-ups on PORTB.

Note: To achieve a 1:1 prescaler assignment for TMR0, assign the prescaler to the WDT (PSA = 1). See Section 6.3.1

REGISTER 3-2: OPTION REGISTER (ADDRESS: 81h, 181h)

R/W-1	R/W-1	R/W-1	R/W-1	R/W-1	R/W-1	R/W-1	R/W-1
$\overline{\text{RBPU}}$	INTEDG	T0CS	T0SE	PSA	PS2	PS1	PS0
bit 7							bit 0

- bit 7 **$\overline{\text{RBPU}}$** : PORTB Pull-up Enable bit
 1 = PORTB pull-ups are disabled
 0 = PORTB pull-ups are enabled by individual port latch values
- bit 6 **INTEDG**: Interrupt Edge Select bit
 1 = Interrupt on rising edge of RB0/INT pin
 0 = Interrupt on falling edge of RB0/INT pin
- bit 5 **T0CS**: TMR0 Clock Source Select bit
 1 = Transition on RA4/T0CKI pin
 0 = Internal instruction cycle clock (CLKOUT)
- bit 4 **T0SE**: TMR0 Source Edge Select bit
 1 = Increment on high-to-low transition on RA4/T0CKI pin
 0 = Increment on low-to-high transition on RA4/T0CKI pin
- bit 3 **PSA**: Prescaler Assignment bit
 1 = Prescaler is assigned to the WDT
 0 = Prescaler is assigned to the Timer0 module
- bit 2-0 **PS2:PS0**: Prescaler Rate Select bits

Bit Value	TMR0 Rate	WDT Rate
000	1 : 2	1 : 1
001	1 : 4	1 : 2
010	1 : 8	1 : 4
011	1 : 16	1 : 8
100	1 : 32	1 : 16
101	1 : 64	1 : 32
110	1 : 128	1 : 64
111	1 : 256	1 : 128

Legend:
 R = Readable bit W = Writable bit U = Unimplemented bit, read as '0'
 -n = Value at POR '1' = Bit is set '0' = Bit is cleared x = Bit is unknown

3.2.2.3 INTCON Register

The INTCON register is a readable and writable register which contains the various enable and flag bits for all interrupt sources except the comparator module. See Section 3.2.2.4 and Section 3.2.2.5 for a description of the comparator enable and flag bits.

Note: Interrupt flag bits get set when an interrupt condition occurs regardless of the state of its corresponding enable bit or the global enable bit, GIE (INTCON<7>).

REGISTER 3-3: INTCON REGISTER (ADDRESS: 0Bh, 8Bh, 10Bh, 18Bh)

	R/W-0	R/W-0	R/W-0	R/W-0	R/W-0	R/W-0	R/W-0	R/W-x
	GIE	PEIE	T0IE	INTE	RBIE	T0IF	INTF	RBIF
bit 7								bit 0

- bit 7 **GIE:** Global Interrupt Enable bit
1 = Enables all unmasked interrupts
0 = Disables all interrupts
- bit 6 **PEIE:** Peripheral Interrupt Enable bit
1 = Enables all unmasked peripheral interrupts
0 = Disables all peripheral interrupts
- bit 5 **T0IE:** TMR0 Overflow Interrupt Enable bit
1 = Enables the TMR0 interrupt
0 = Disables the TMR0 interrupt
- bit 4 **INTE:** RB0/INT External Interrupt Enable bit
1 = Enables the RB0/INT external interrupt
0 = Disables the RB0/INT external interrupt
- bit 3 **RBIE:** RB Port Change Interrupt Enable bit
1 = Enables the RB port change interrupt
0 = Disables the RB port change interrupt
- bit 2 **T0IF:** TMR0 Overflow Interrupt Flag bit
1 = TMR0 register has overflowed (must be cleared in software)
0 = TMR0 register did not overflow
- bit 1 **INTF:** RB0/INT External Interrupt Flag bit
1 = The RB0/INT external interrupt occurred (must be cleared in software)
0 = The RB0/INT external interrupt did not occur
- bit 0 **RBIF:** RB Port Change Interrupt Flag bit
1 = When at least one of the RB7:RB4 pins changed state (must be cleared in software)
0 = None of the RB7:RB4 pins have changed state

Legend:

R = Readable bit	W = Writable bit	U = Unimplemented bit, read as '0'
-n = Value at POR	'1' = Bit is set	'0' = Bit is cleared x = Bit is unknown

PIC16F62X

3.2.2.4 PIE1 Register

This register contains interrupt enable bits.

REGISTER 3-4: PIE1 REGISTER (ADDRESS: 8Ch)

R/W-0	R/W-0	R/W-0	R/W-0	U-0	R/W-0	R/W-0	R/W-0
EEIE	CMIE	RCIE	TXIE	—	CCP1IE	TMR2IE	TMR1IE
bit 7							bit 0

- bit 7 **EEIE:** EE Write Complete Interrupt Enable Bit
1 = Enables the EE write complete interrupt
0 = Disables the EE write complete interrupt
- bit 6 **CMIE:** Comparator Interrupt Enable bit
1 = Enables the comparator interrupt
0 = Disables the comparator interrupt
- bit 5 **RCIE:** USART Receive Interrupt Enable bit
1 = Enables the USART receive interrupt
0 = Disables the USART receive interrupt
- bit 4 **TXIE:** USART Transmit Interrupt Enable bit
1 = Enables the USART transmit interrupt
0 = Disables the USART transmit interrupt
- bit 3 **Unimplemented:** Read as '0'
- bit 2 **CCP1IE:** CCP1 Interrupt Enable bit
1 = Enables the CCP1 interrupt
0 = Disables the CCP1 interrupt
- bit 1 **TMR2IE:** TMR2 to PR2 Match Interrupt Enable bit
1 = Enables the TMR2 to PR2 match interrupt
0 = Disables the TMR2 to PR2 match interrupt
- bit 0 **TMR1IE:** TMR1 Overflow Interrupt Enable bit
1 = Enables the TMR1 overflow interrupt
0 = Disables the TMR1 overflow interrupt

Legend:

R = Readable bit	W = Writable bit	U = Unimplemented bit, read as '0'
-n = Value at POR	'1' = Bit is set	'0' = Bit is cleared x = Bit is unknown

3.2.2.5 PIR1 Register

This register contains interrupt flag bits.

Note: Interrupt flag bits get set when an interrupt condition occurs regardless of the state of its corresponding enable bit or the global enable bit, GIE (INTCON<7>). User software should ensure the appropriate interrupt flag bits are clear prior to enabling an interrupt.

REGISTER 3-5: PIR1 REGISTER (ADDRESS: 0Ch)

R/W-0	R/W-0	R-0	R-0	U-0	R/W-0	R/W-0	R/W-0
EEIF	CMIF	RCIF	TXIF	—	CCP1IF	TMR2IF	TMR1IF
bit 7				bit 0			

- bit 7 **EEIF:** EEPROM Write Operation Interrupt Flag bit
 1 = The write operation completed (must be cleared in software)
 0 = The write operation has not completed or has not been started
- bit 6 **CMIF:** Comparator Interrupt Flag bit
 1 = Comparator output has changed
 0 = Comparator output has not changed
- bit 5 **RCIF:** USART Receive Interrupt Flag bit
 1 = The USART receive buffer is full
 0 = The USART receive buffer is empty
- bit 4 **TXIF:** USART Transmit Interrupt Flag bit
 1 = The USART transmit buffer is empty
 0 = The USART transmit buffer is full
- bit 3 **Unimplemented:** Read as '0'
- bit 2 **CCP1IF:** CCP1 Interrupt Flag bit
Capture Mode
 1 = A TMR1 register capture occurred (must be cleared in software)
 0 = No TMR1 register capture occurred
Compare Mode
 1 = A TMR1 register compare match occurred (must be cleared in software)
 0 = No TMR1 register compare match occurred
PWM Mode
 Unused in this mode
- bit 1 **TMR2IF:** TMR2 to PR2 Match Interrupt Flag bit
 1 = TMR2 to PR2 match occurred (must be cleared in software)
 0 = No TMR2 to PR2 match occurred
- bit 0 **TMR1IF:** TMR1 Overflow Interrupt Flag bit
 1 = TMR1 register overflowed (must be cleared in software)
 0 = TMR1 register did not overflow

Legend:

R = Readable bit	W = Writable bit	U = Unimplemented bit, read as '0'
-n = Value at POR	'1' = Bit is set	'0' = Bit is cleared x = Bit is unknown

PIC16F62X

3.2.2.6 PCON Register

The PCON register contains flag bits to differentiate between a Power-on Reset, an external MCLR Reset, WDT Reset or a Brown-out Detect.

Note: $\overline{\text{BOD}}$ is unknown on Power-on Reset. It must then be set by the user and checked on subsequent RESETS to see if $\overline{\text{BOD}}$ is cleared, indicating a brown-out has occurred. The BOD STATUS bit is a “don't care” and is not necessarily predictable if the brown-out circuit is disabled (by clearing the BODEN bit in the Configuration word).

REGISTER 3-6: PCON REGISTER (ADDRESS: 0Ch)

	U-0	U-0	U-0	U-0	R/W-1	U-0	R/W-q	R/W-q
	—	—	—	—	OSCF	—	$\overline{\text{POR}}$	$\overline{\text{BOD}}$
	bit 7							bit 0

bit 7-4 **Unimplemented:** Read as '0'

bit 3 **OSCF:** INTRC/ER oscillator frequency

1 = 4 MHz typical⁽¹⁾

0 = 37 KHz typical

bit 2 **Unimplemented:** Read as '0'

bit 1 **$\overline{\text{POR}}$:** Power-on Reset STATUS bit

1 = No Power-on Reset occurred

0 = A Power-on Reset occurred (must be set in software after a Power-on Reset occurs)

bit 0 **$\overline{\text{BOD}}$:** Brown-out Detect STATUS bit

1 = No Brown-out Reset occurred

0 = A Brown-out Reset occurred (must be set in software after a Brown-out Reset occurs)

Note 1: When in ER Oscillator mode, setting OSCF = 1 will cause the oscillator frequency to change to the frequency specified by the external resistor.

Legend:

R = Readable bit

W = Writable bit

U = Unimplemented bit, read as '0'

-n = Value at POR

'1' = Bit is set

'0' = Bit is cleared

x = Bit is unknown

3.3 PCL and PCLATH

The program counter (PC) is 13-bits wide. The low byte comes from the PCL register, which is a readable and writable register. The high byte (PC<12:8>) is not directly readable or writable and comes from PCLATH. On any RESET, the PC is cleared. Figure 3-3 shows the two situations for the loading of the PC. The upper example in the figure shows how the PC is loaded on a write to PCL (PCLATH<4:0> → PCH). The lower example in the figure shows how the PC is loaded during a CALL or GOTO instruction (PCLATH<4:3> → PCH).

FIGURE 3-3: LOADING OF PC IN DIFFERENT SITUATIONS

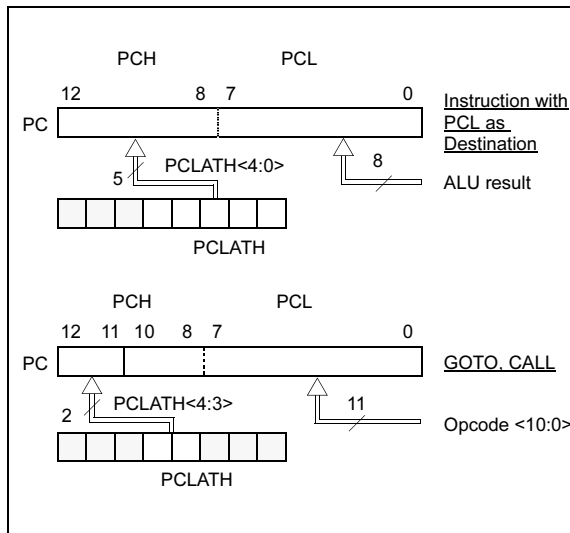

3.3.1 COMPUTED GOTO

A computed GOTO is accomplished by adding an offset to the program counter (ADDWF PCL). When doing a table read using a computed GOTO method, care should be exercised if the table location crosses a PCL memory boundary (each 256 byte block). Refer to the application note "Implementing a Table Read" (AN556).

3.3.2 STACK

The PIC16F62X family has an 8-level deep x 13-bit wide hardware stack (Figure 3-1 and Figure 3-2). The stack space is not part of either program or data space and the stack pointer is not readable or writable. The PC is PUSHed onto the stack when a CALL instruction is executed or an interrupt causes a branch. The stack is POPed in the event of a RETURN, RETLW or a RETFIE instruction execution. PCLATH is not affected by a PUSH or POP operation.

The stack operates as a circular buffer. This means that after the stack has been PUSHed eight times, the ninth push overwrites the value that was stored from the first push. The tenth push overwrites the second push (and so on).

Note 1: There are no STATUS bits to indicate stack overflow or stack underflow conditions.

2: There are no instructions/mnemonics called PUSH or POP. These are actions that occur from the execution of the CALL, RETURN, RETLW and RETFIE instructions, or the vectoring to an interrupt address.

3.4 Indirect Addressing, INDF and FSR Registers

The INDF register is not a physical register. Addressing the INDF register will cause indirect addressing.

Indirect addressing is possible by using the INDF register. Any instruction using the INDF register actually accesses data pointed to by the file select register (FSR). Reading INDF itself indirectly will produce 00h. Writing to the INDF register indirectly results in a no-operation (although STATUS bits may be affected). An effective 9-bit address is obtained by concatenating the 8-bit FSR register and the IRP bit (STATUS<7>), as shown in Figure 3-4.

A simple program to clear RAM location 20h-2Fh using indirect addressing is shown in Example 3-1.

EXAMPLE 3-1: Indirect Addressing

```

movlw 0x20 ;initialize pointer
movwf FSR ;to RAM
NEXT   clrf INDF ;clear INDF register
       incf FSR ;inc pointer
       btfss FSR,4 ;all done?
       goto NEXT ;no clear next
                          ;yes continue
    
```

PIC16F62X

FIGURE 3-4: DIRECT/INDIRECT ADDRESSING PIC16F62X

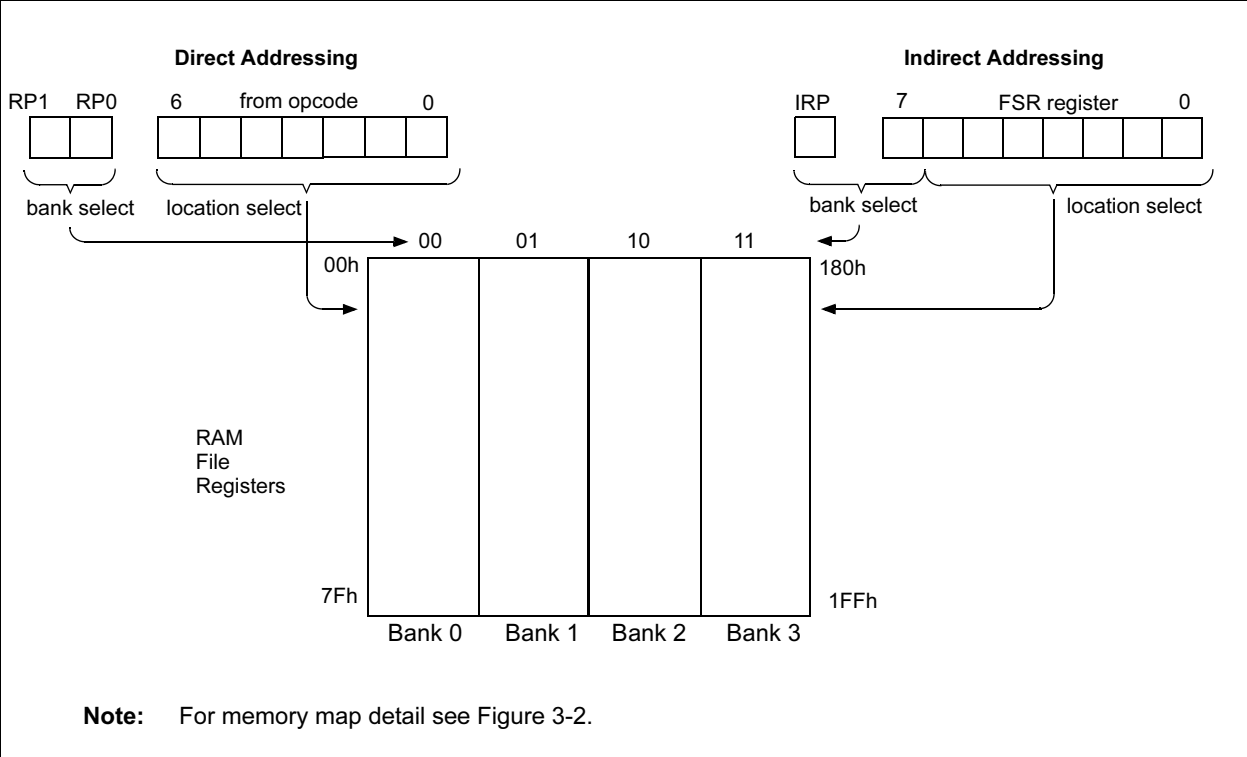

4.0 GENERAL DESCRIPTION

The PIC16F62X are 18-Pin FLASH-based members of the versatile PIC16CXX family of low cost, high performance, CMOS, fully static, 8-bit microcontrollers.

All PICmicro® microcontrollers employ an advanced RISC architecture. The PIC16F62X have enhanced core features, eight-level deep stack, and multiple internal and external interrupt sources. The separate instruction and data buses of the Harvard architecture allow a 14-bit wide instruction word with the separate 8-bit wide data. The two-stage instruction pipeline allows all instructions to execute in a single cycle, except for program branches (which require two cycles). A total of 35 instructions (reduced instruction set) are available. Additionally, a large register set gives some of the architectural innovations used to achieve a very high performance.

PIC16F62X microcontrollers typically achieve a 2:1 code compression and a 4:1 speed improvement over other 8-bit microcontrollers in their class.

PIC16F62X devices have special features to reduce external components, thus reducing system cost, enhancing system reliability and reducing power consumption.

The PIC16F62X has eight oscillator configurations. The single pin ER oscillator provides a low cost solution. The LP oscillator minimizes power consumption, XT is a standard crystal, INTRC is a self-contained internal oscillator. The HS is for High Speed crystals. The EC mode is for an external clock source.

The SLEEP (Power-down) mode offers power savings. The user can wake-up the chip from SLEEP through several external interrupts, internal interrupts, and RESETS.

A highly reliable Watchdog Timer with its own on-chip RC oscillator provides protection against software lock-up.

Table 4-1 shows the features of the PIC16F62X mid-range microcontroller families.

A simplified block diagram of the PIC16F62X is shown in Figure 2.1.

The PIC16F62X series fits in applications ranging from battery chargers to low power remote sensors. The FLASH technology makes customization of application programs (detection levels, pulse generation, timers, etc.) extremely fast and convenient. The small footprint packages make this microcontroller series ideal for all applications with space limitations. Low cost, low power, high performance, ease of use and I/O flexibility make the PIC16F62X very versatile.

4.1 Development Support

The PIC16F62X family is supported by a full featured macro assembler, a software simulator, an in-circuit emulator, a low cost development programmer and a full-featured programmer. A Third Party "C" compiler support tool is also available.

TABLE 4-1: PIC16F62X FAMILY OF DEVICES

		PIC16F627	PIC16F628	PIC16LF627	PIC16LF628
Clock	Maximum Frequency of Operation (MHz)	20	20	4	4
	Memory				
Memory	FLASH Program Memory (words)	1024	2048	1024	2048
	RAM Data Memory (bytes)	224	224	224	224
	EEPROM Data Memory (bytes)	128	128	128	128
Peripherals	Timer Module(s)	TMR0, TMR1, TMR2	TMR0, TMR1, TMR2	TMR0, TMR1, TMR2	TMR0, TMR1, TMR2
	Comparator(s)	2	2	2	2
	Capture/Compare/PWM modules	1	1	1	1
	Serial Communications	USART	USART	USART	USART
	Internal Voltage Reference	Yes	Yes	Yes	Yes
Features	Interrupt Sources	10	10	10	10
	I/O Pins	16	16	16	16
	Voltage Range (Volts)	3.0-5.5	3.0-5.5	2.0-5.5	2.0-5.5
	Brown-out Detect	Yes	Yes	Yes	Yes
	Packages	18-pin DIP, SOIC, 20-pin SSOP	18-pin DIP, SOIC, 20-pin SSOP	18-pin DIP, SOIC, 20-pin SSOP	18-pin DIP, SOIC, 20-pin SSOP

All PICmicro® Family devices have Power-on Reset, selectable Watchdog Timer, selectable code protect and high I/O current capability. All PIC16F62X Family devices use serial programming with clock pin RB6 and data pin RB7.

PIC16F62X

NOTES:

5.0 I/O PORTS

The PIC16F62X have two ports, PORTA and PORTB. Some pins for these I/O ports are multiplexed with an alternate function for the peripheral features on the device. In general, when a peripheral is enabled, that pin may not be used as a general purpose I/O pin.

5.1 PORTA and TRISA Registers

PORTA is an 8-bit wide latch. RA4 is a Schmitt Trigger input and an open drain output. Port RA4 is multiplexed with the T0CKI clock input. RA5 is a Schmitt Trigger input only and has no output drivers. All other RA port pins have Schmitt Trigger input levels and full CMOS output drivers. All pins have data direction bits (TRIS registers) which can configure these pins as input or output.

A '1' in the TRISA register puts the corresponding output driver in a Hi-impedance mode. A '0' in the TRISA register puts the contents of the output latch on the selected pin(s).

Reading the PORTA register reads the status of the pins whereas writing to it will write to the port latch. All write operations are read-modify-write operations. So a write to a port implies that the port pins are first read, then this value is modified and written to the port data latch.

The PORTA pins are multiplexed with comparator and voltage reference functions. The operation of these pins are selected by control bits in the CMCON (comparator control register) register and the VRCON (voltage reference control register) register. When selected as a comparator input, these pins will read as '0's.

Note: RA5 shares function with VPP. When VPP voltage levels are applied to RA5, the device will enter Programming mode.

Note 1: On RESET, the TRISA register is set to all inputs. The digital inputs are disabled and the comparator inputs are forced to ground to reduce current consumption.

2: TRISA<6:7> is overridden by oscillator configuration. When PORTA<6:7> is overridden, the data reads '0' and the TRISA<6:7> bits are ignored.

TRISA controls the direction of the RA pins, even when they are being used as comparator inputs. The user must make sure to keep the pins configured as inputs when using them as comparator inputs.

The RA2 pin will also function as the output for the voltage reference. When in this mode, the VREF pin is a very high impedance output. The user must configure TRISA<2> bit as an input and use high impedance loads.

In one of the Comparator modes defined by the CMCON register, pins RA3 and RA4 become outputs of the comparators. The TRISA<4:3> bits must be cleared to enable outputs to use this function.

EXAMPLE 5-1: Initializing PORTA

```
CLRF  PORTA      ;Initialize PORTA by
                  ;setting output data latches
MOVLW 0x07      ;Turn comparators off and
MOVWF  CMCON     ;enable pins for I/O
                  ;functions
BCF    STATUS, RP1
BSF    STATUS, RP0;Select Bank1
MOVLW 0x1F      ;Value used to initialize
                  ;data direction
MOVWF  TRISA     ;Set RA<4:0> as inputs
                  ;TRISA<5> always
                  ;read as '1'.
                  ;TRISA<7:6>
                  ;depend on oscillator mode
```

PIC16F62X

FIGURE 5-1: BLOCK DIAGRAM OF RA0/AN0:RA1/AN1 PINS

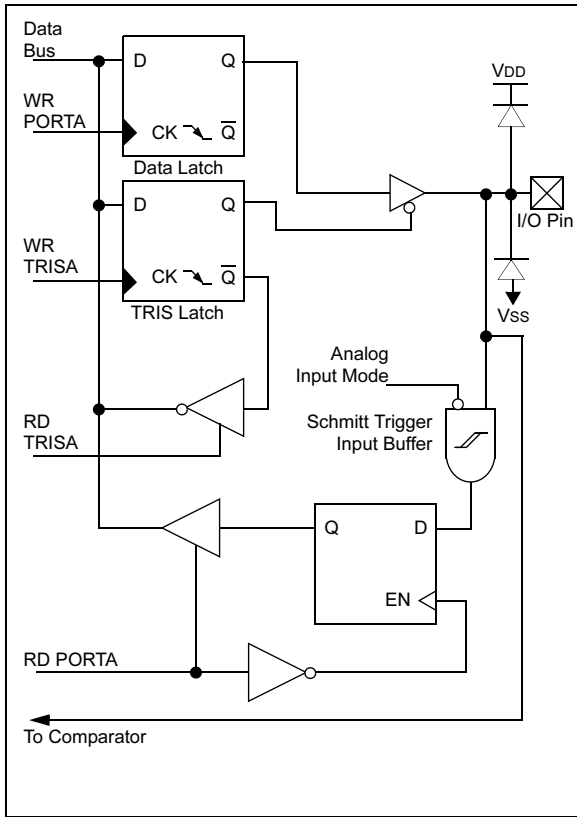

FIGURE 5-2: BLOCK DIAGRAM OF RA2/VREF PIN

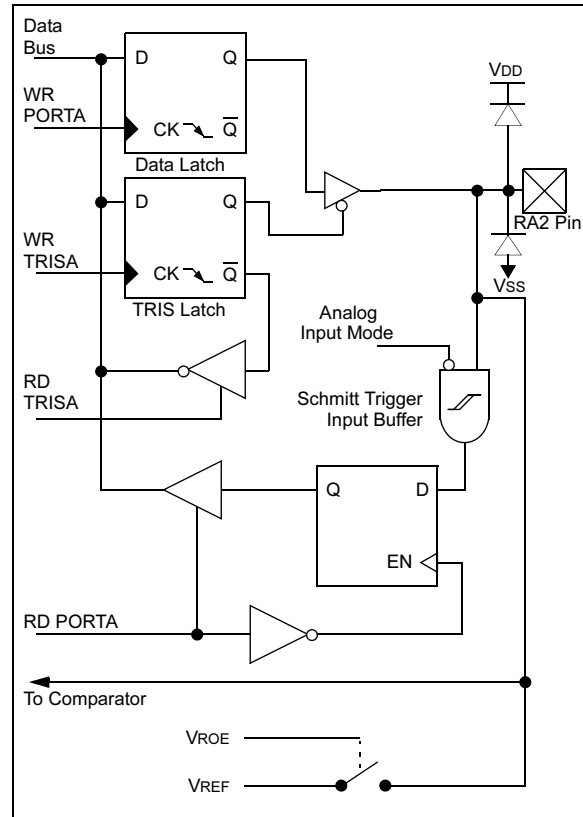
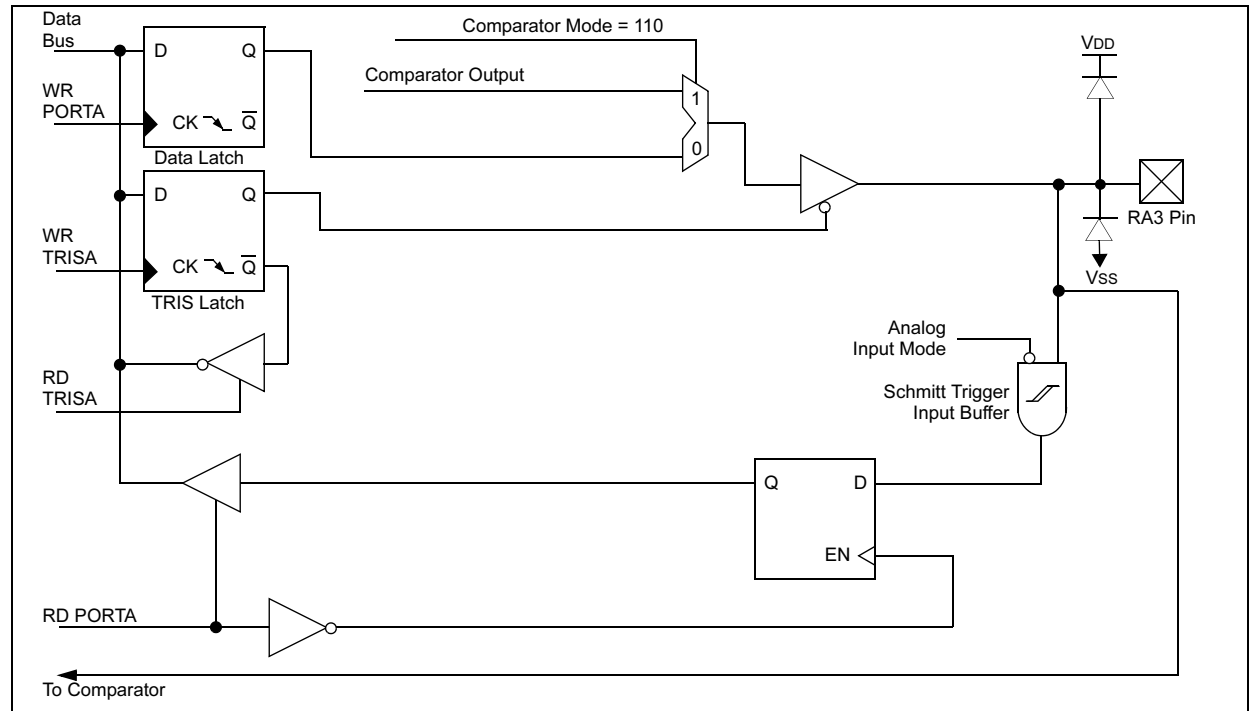

FIGURE 5-3: BLOCK DIAGRAM OF THE RA3/AN3 PIN



PIC16F62X

FIGURE 5-7: BLOCK DIAGRAM OF RA7/OSC1/CLKIN PIN

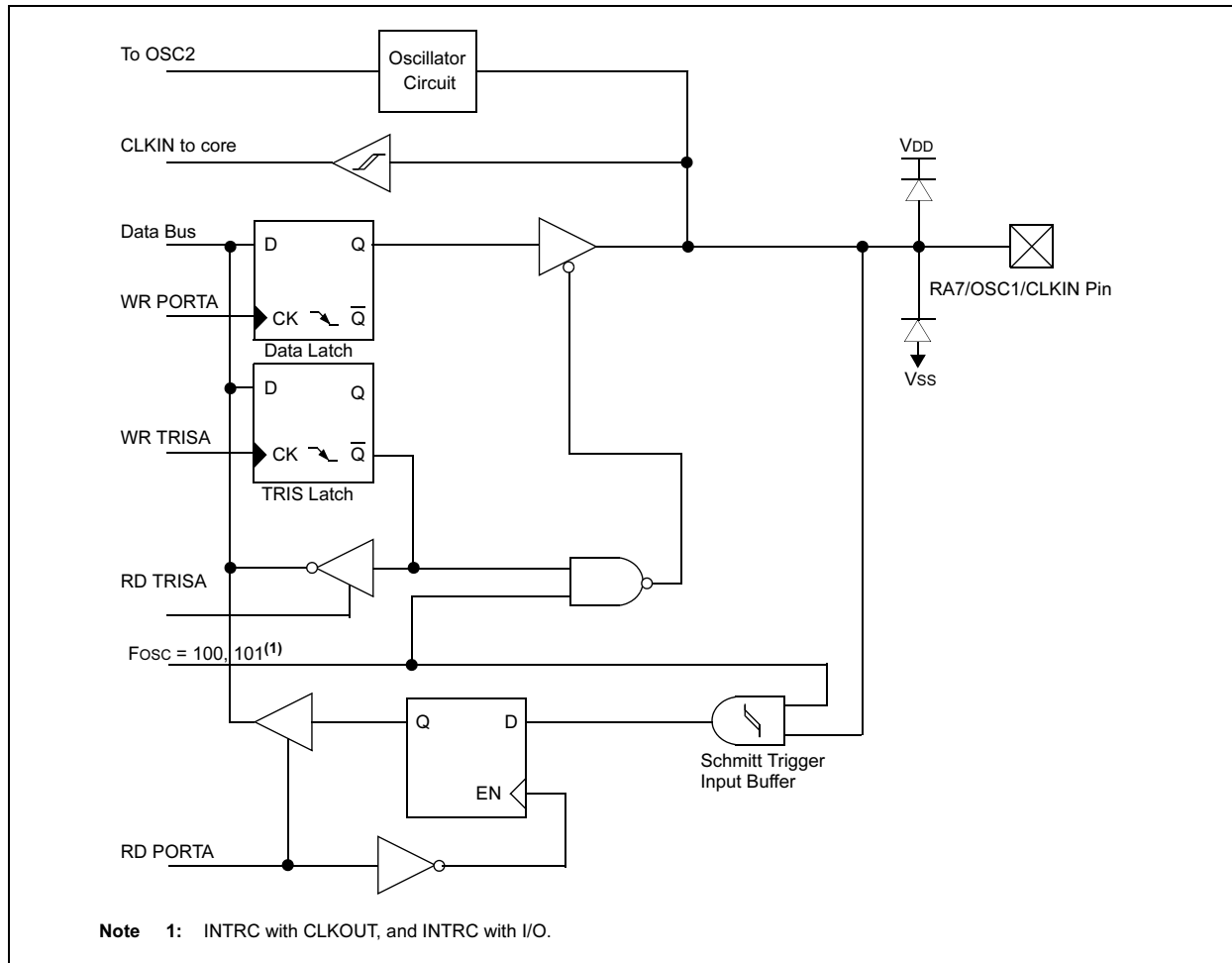

TABLE 5-1: PORTA FUNCTIONS

Name	Function	Input Type	Output Type	Description
RA0/AN0	RA0	ST	CMOS	Bi-directional I/O port
	AN0	AN	—	Analog comparator input
RA1/AN1	RA1	ST	CMOS	Bi-directional I/O port
	AN1	AN	—	Analog comparator input
RA2/AN2/VREF	RA2	ST	CMOS	Bi-directional I/O port
	AN2	AN	—	Analog comparator input
	VREF	—	AN	VREF output
RA3/AN3/CMP1	RA3	ST	CMOS	Bi-directional I/O port
	AN3	AN	—	Analog comparator input
	CMP1	—	CMOS	Comparator 1 output
RA4/T0CKI/CMP2	RA4	ST	OD	Bi-directional I/O port
	T0CKI	ST	—	External clock input for TMR0 or comparator output. Output is open drain type
	CMP2	—	OD	Comparator 2 output
RA5/ $\overline{\text{MCLR}}$ /VPP	RA5	ST	—	Input port
	$\overline{\text{MCLR}}$	ST	—	Master clear
	VPP	HV	—	Programming voltage input. When configured as $\overline{\text{MCLR}}$, this pin is an active low RESET to the device. Voltage on $\overline{\text{MCLR}}$ /VPP must not exceed VDD during normal device operation
RA6/OSC2/CLKOUT	RA6	ST	CMOS	Bi-directional I/O port.
	OSC2	XTAL	—	Oscillator crystal output. Connects to crystal resonator in Crystal Oscillator mode.
	CLKOUT	—	CMOS	In ER/INTRC mode, OSC2 pin can output CLKOUT, which has 1/4 the frequency of OSC1
RA7/OSC1/CLKIN	RA7	ST	CMOS	Bi-directional I/O port
	OSC1	XTAL	—	Oscillator crystal input
	CLKIN	ST	—	External clock source input. ER biasing pin.

Legend: ST = Schmitt Trigger input HV = High Voltage OD = Open Drain AN = Analog

PIC16F62X

TABLE 5-2: SUMMARY OF REGISTERS ASSOCIATED WITH PORTA⁽¹⁾

Address	Name	Bit 7	Bit 6	Bit 5	Bit 4	Bit 3	Bit 2	Bit 1	Bit 0	Value on POR	Value on All Other RESETS
05h	PORTA	RA7	RA6	RA5	RA4	RA3	RA2	RA1	RA0	xxxx 0000	xxxxu 0000
85h	TRISA	TRISA7	TRISA6	TRISA5	TRISA4	TRISA3	TRISA2	TRISA1	TRISA0	1111 1111	1111 1111
1Fh	CMCON	C2OUT	C1OUT	C2INV	C1INV	CIS	CM2	CM1	CM0	0000 0000	0000 0000
9Fh	VRCON	VREN	VROE	VRR	—	VR3	VR2	VR1	VR0	000- 0000	000- 0000

Legend: — = Unimplemented locations, read as '0', u = unchanged, x = unknown

Note 1: Shaded bits are not used by PORTA.

5.2 PORTB and TRISB Registers

PORTB is an 8-bit wide bi-directional port. The corresponding data direction register is TRISB. A '1' in the TRISB register puts the corresponding output driver in a Hi-impedance mode. A '0' in the TRISB register puts the contents of the output latch on the selected pin(s).

PORTB is multiplexed with the external interrupt, USART, CCP module and the TMR1 clock input/output. The standard port functions and the alternate port functions are shown in Table 5-3. Alternate port functions override TRIS setting when enabled.

Reading PORTB register reads the status of the pins, whereas writing to it will write to the port latch. All write operations are read-modify-write operations. So a write to a port implies that the port pins are first read, then this value is modified and written to the port data latch.

Each of the PORTB pins has a weak internal pull-up ($\approx 200 \mu\text{A}$ typical). A single control bit can turn on all the pull-ups. This is done by clearing the RBPU (OPTION<7>) bit. The weak pull-up is automatically turned off when the port pin is configured as an output. The pull-ups are disabled on Power-on Reset.

Four of PORTB's pins, RB<7:4>, have an interrupt-on-change feature. Only pins configured as inputs can cause this interrupt to occur (i.e., any RB<7:4> pin configured as an output is excluded from the interrupt-on-change comparison). The input pins (of RB7:RB4) are compared with the old value latched on the last read of PORTB. The "mismatch" outputs of RB7:RB4 are OR'ed together to generate the RBIF interrupt (flag latched in INTCON<0>).

This interrupt can wake the device from SLEEP. The user, in the interrupt service routine, can clear the interrupt in the following manner:

- Any read or write of PORTB. This will end the mismatch condition.
- Clear flag bit RBIF.

A mismatch condition will continue to set flag bit RBIF. Reading PORTB will end the mismatch condition and allow flag bit RBIF to be cleared.

This interrupt on mismatch feature, together with software configurable pull-ups on these four pins allow easy interface to a key pad and make it possible for wake-up on key-depression. (See AN552)

Note: If a change on the I/O pin should occur when a read operation is being executed (start of the Q2 cycle), then the RBIF interrupt flag may not get set.

The interrupt-on-change feature is recommended for wake-up on key depression operation and operations where PORTB is only used for the interrupt-on-change feature. Polling of PORTB is not recommended while using the interrupt-on-change feature.

FIGURE 5-8: BLOCK DIAGRAM OF RB0/INT PIN

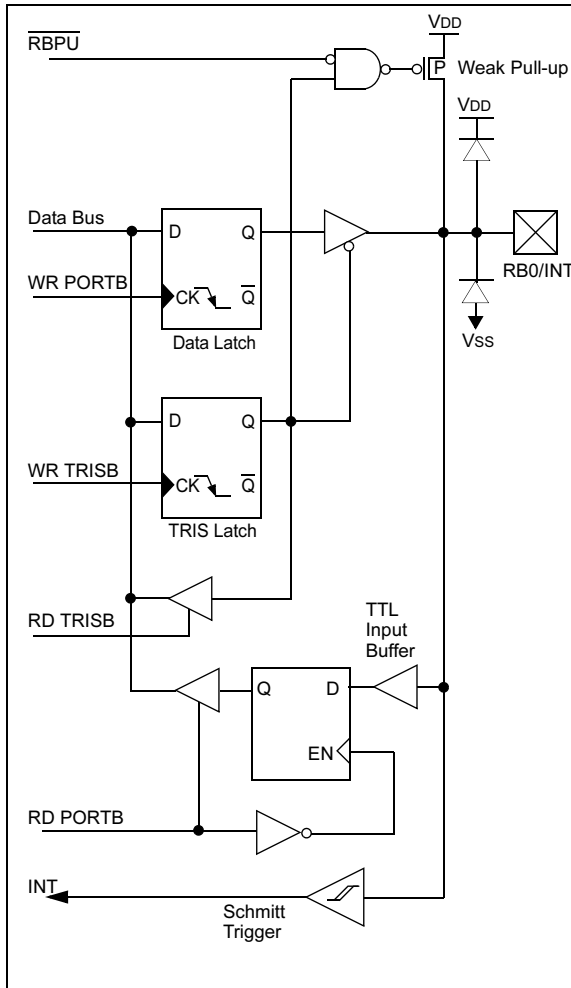
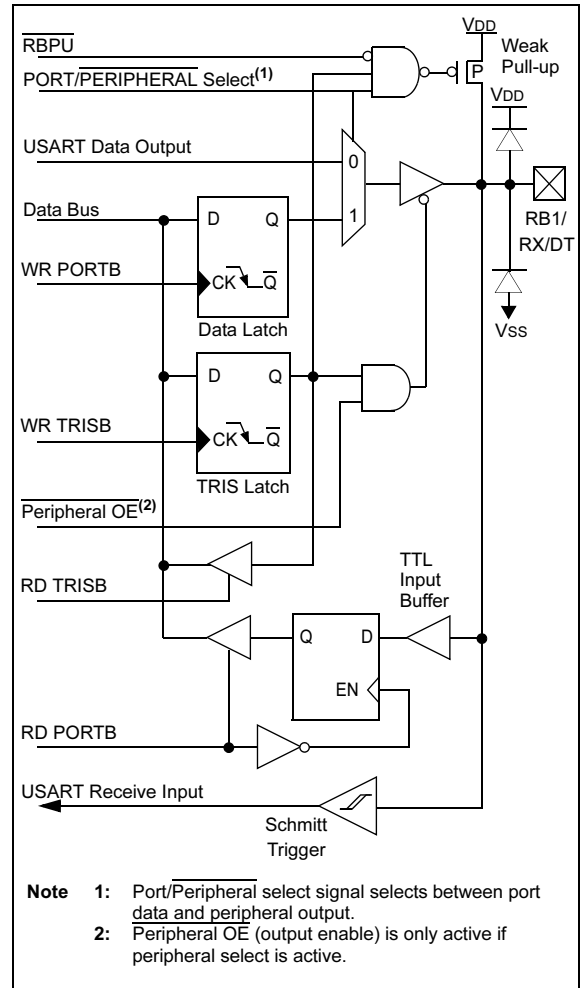

FIGURE 5-9: BLOCK DIAGRAM OF RB1/RX/DT PIN



PIC16F62X

FIGURE 5-10: BLOCK DIAGRAM OF RB2/TX/CK PIN

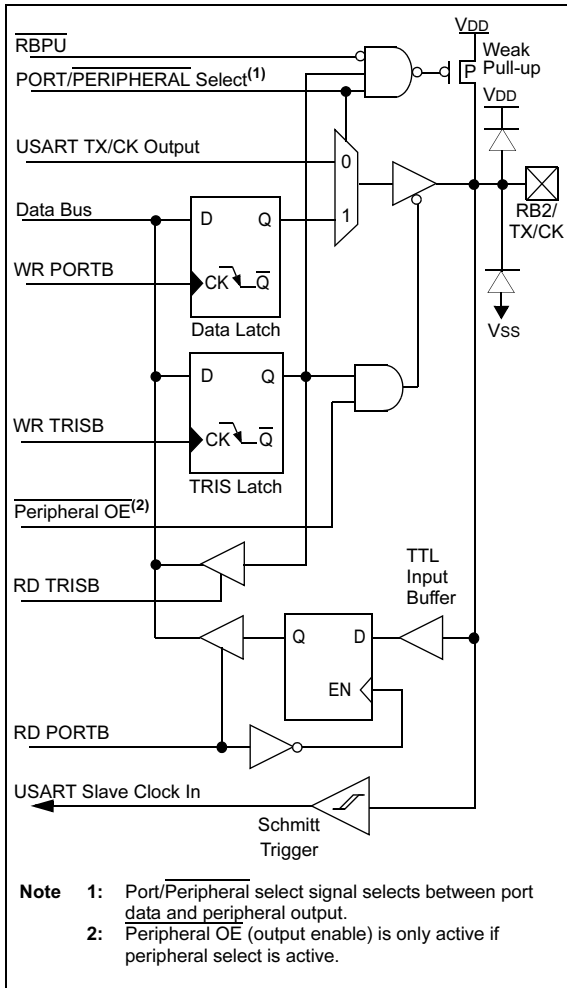

FIGURE 5-11: BLOCK DIAGRAM OF RB3/CCP1 PIN

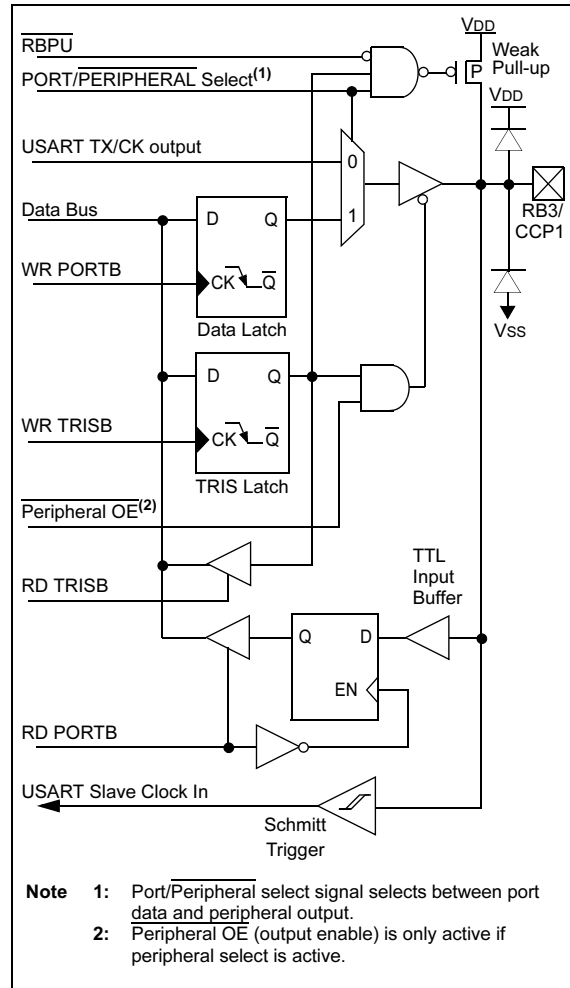
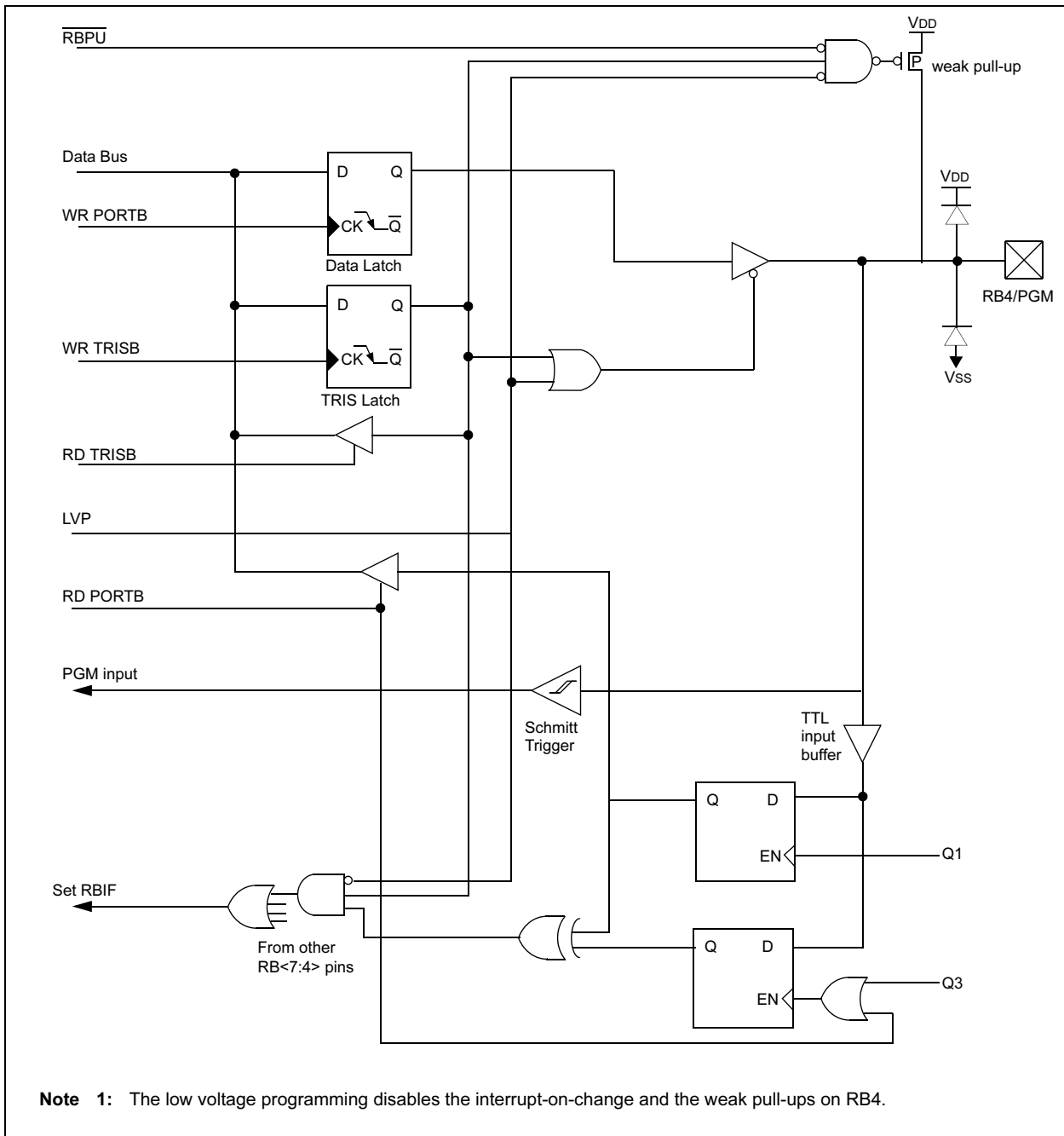

FIGURE 5-12: BLOCK DIAGRAM OF RB4/PGM PIN



PIC16F62X

FIGURE 5-13: BLOCK DIAGRAM OF RB5 PIN

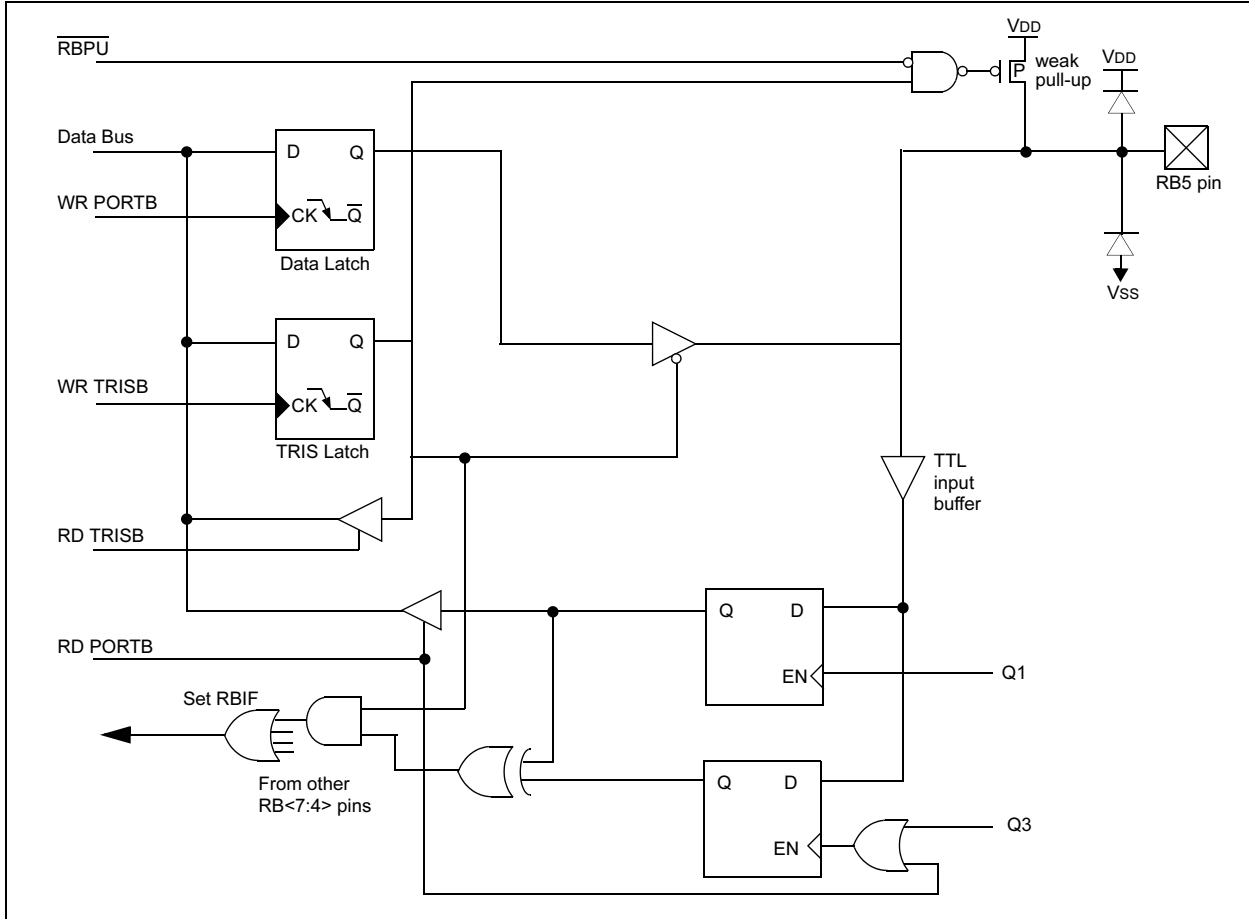
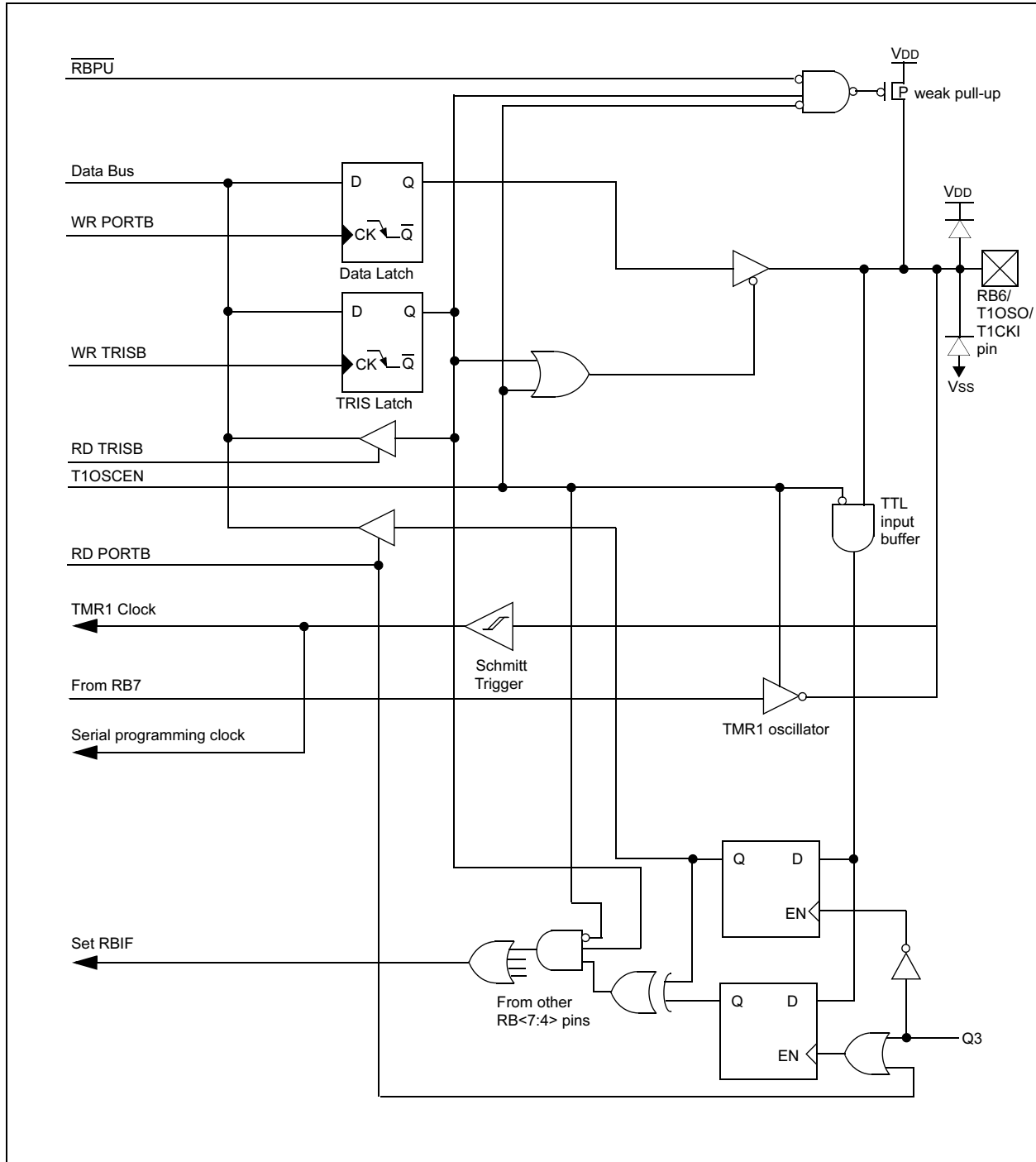
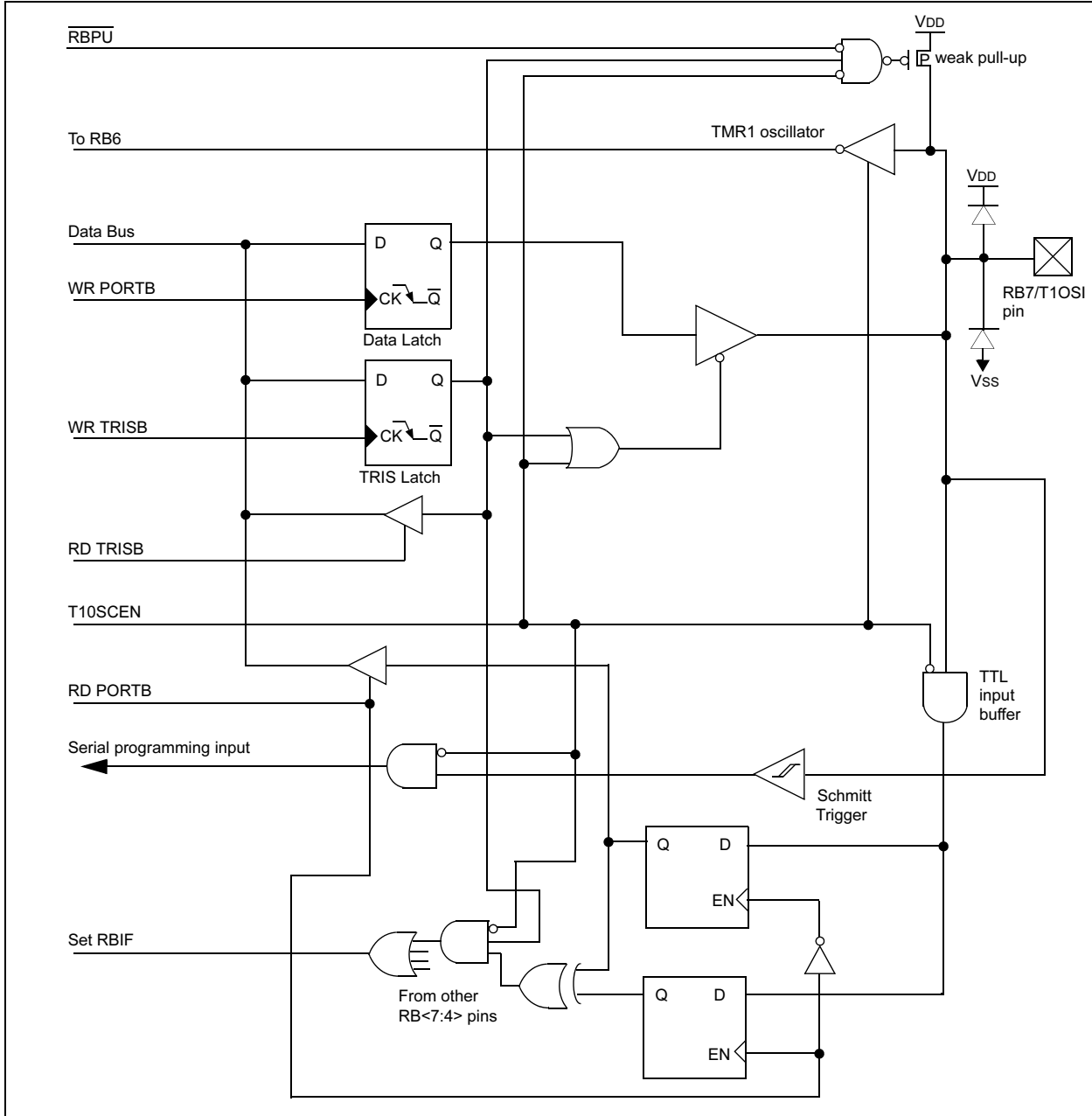

FIGURE 5-14: BLOCK DIAGRAM OF RB6/T1OSO/T1CKI PIN



PIC16F62X

FIGURE 5-15: BLOCK DIAGRAM OF THE RB7/T10SI PIN



PIC16F62X

5.3 I/O Programming Considerations

5.3.1 BI-DIRECTIONAL I/O PORTS

Any instruction which writes, operates internally as a read followed by a write operation. The `BCF` and `BSF` instructions, for example, read the register into the CPU, execute the bit operation and write the result back to the register. Caution must be used when these instructions are applied to a port with both inputs and outputs defined. For example, a `BSF` operation on Bit 5 of `PORTB` will cause all eight bits of `PORTB` to be read into the CPU. Then the `BSF` operation takes place on Bit 5 and `PORTB` is written to the output latches. If another bit of `PORTB` is used as a bi-directional I/O pin (e.g., Bit 0) and it is defined as an input at this time, the input signal present on the pin itself would be read into the CPU and rewritten to the data latch of this particular pin, overwriting the previous content. As long as the pin stays in the Input mode, no problem occurs. However, if Bit 0 is switched into Output mode later on, the content of the data latch may now be unknown.

Reading a port register, reads the values of the port pins. Writing to the port register writes the value to the port latch. When using read-modify-write instructions (ex. `BCF`, `BSF`, etc.) on a port, the value of the port pins is read, the desired operation is done to this value, and this value is then written to the port latch.

Example 5-2 shows the effect of two sequential read-modify-write instructions (ex., `BCF`, `BSF`, etc.) on an I/O port.

A pin actively outputting a Low or High should not be driven from external devices at the same time in order to change the level on this pin (“wired-or”, “wired-and”). The resulting high output currents may damage the chip.

EXAMPLE 5-2: READ-MODIFY-WRITE INSTRUCTIONS ON AN I/O PORT

```

;Initial PORT settings:PORTB<7:4> Inputs
;
;                                PORTB<3:0> Outputs
;PORTB<7:6> have external pull-up and are not
;connected to other circuitry
;
;                                PORT latchPORT Pins
;                                -----
BCF STATUS, RP0      ;
BCF PORTB, 7         ;01pp pppp 11pp pppp
BSF STATUS, RP0      ;
BCF TRISB, 7         ;10pp pppp 11pp pppp
BCF TRISB, 6         ;10pp pppp 10pp pppp
;
;Note that the user may have expected the pin
;values to be 00pp pppp. The 2nd BCF caused
;RB7 to be latched as the pin value (High).
    
```

5.3.2 SUCCESSIVE OPERATIONS ON I/O PORTS

The actual write to an I/O port happens at the end of an instruction cycle, whereas for reading, the data must be valid at the beginning of the instruction cycle (Figure 5-16). Therefore, care must be exercised if a write followed by a read operation is carried out on the same I/O port. The sequence of instructions should be such to allow the pin voltage to stabilize (load dependent) before the next instruction which causes that file to be read into the CPU is executed. Otherwise, the previous state of that pin may be read into the CPU rather than the new state. When in doubt, it is better to separate these instructions with a `NOP` or another instruction not accessing this I/O port.

FIGURE 5-16: SUCCESSIVE I/O OPERATION

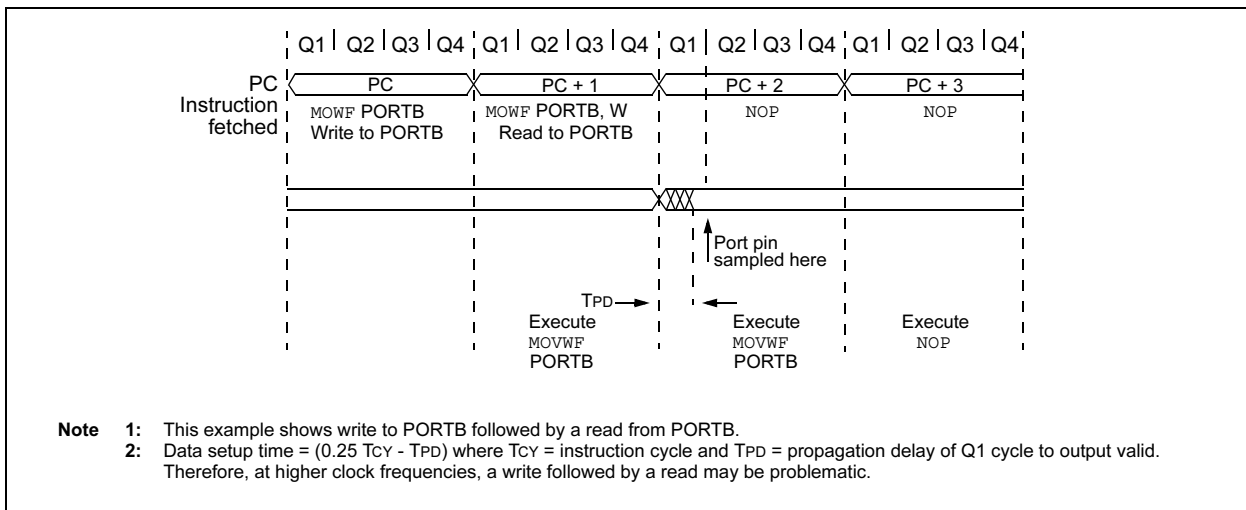

6.0 TIMER0 MODULE

The Timer0 module timer/counter has the following features:

- 8-bit timer/counter
- Readable and writable
- 8-bit software programmable prescaler
- Internal or external clock select
- Interrupt on overflow from FFh to 00h
- Edge select for external clock

Figure 6-1 is a simplified block diagram of the Timer0 module. Additional information available in the PICmicro™ Mid-Range MCU Family Reference Manual, DS31010A.

Timer mode is selected by clearing the T0CS bit (OPTION<5>). In Timer mode, the TMR0 will increment every instruction cycle (without prescaler). If Timer0 is written, the increment is inhibited for the following two cycles. The user can work around this by writing an adjusted value to TMR0.

Counter mode is selected by setting the T0CS bit. In this mode Timer0 will increment either on every rising or falling edge of pin RA4/T0CKI. The incrementing edge is determined by the source edge (T0SE) control bit (OPTION<4>). Clearing the T0SE bit selects the rising edge. Restrictions on the external clock input are discussed in detail in Section 6.2.

The prescaler is shared between the Timer0 module and the Watchdog Timer. The prescaler assignment is controlled in software by the control bit PSA (OPTION<3>). Clearing the PSA bit will assign the prescaler to Timer0. The prescaler is not readable or writable. When the prescaler is assigned to the Timer0 module, prescale value of 1:2, 1:4,..., 1:256 are selectable. Section 6.3 details the operation of the prescaler.

6.1 TIMER0 Interrupt

Timer0 interrupt is generated when the TMR0 register timer/counter overflows from FFh to 00h. This overflow sets the T0IF bit. The interrupt can be masked by clearing the T0IE bit (INTCON<5>). The T0IF bit (INTCON<2>) must be cleared in software by the Timer0 module interrupt service routine before re-enabling this interrupt. The Timer0 interrupt cannot wake the processor from SLEEP since the timer is shut off during SLEEP.

6.2 Using Timer0 with External Clock

When an external clock input is used for Timer0, it must meet certain requirements. The external clock requirement is due to internal phase clock (Tosc) synchronization. Also, there is a delay in the actual incrementing of Timer0 after synchronization.

6.2.1 EXTERNAL CLOCK SYNCHRONIZATION

When no prescaler is used, the external clock input is the same as the prescaler output. The synchronization of T0CKI with the internal phase clocks is accomplished by sampling the prescaler output on the Q2 and Q4 cycles of the internal phase clocks (Figure 6-1). Therefore, it is necessary for T0CKI to be high for at least 2Tosc (and a small RC delay of 20 ns) and low for at least 2Tosc (and a small RC delay of 20 ns). Refer to the electrical specification of the desired device.

When a prescaler is used, the external clock input is divided by the asynchronous ripple-counter type prescaler so that the prescaler output is symmetrical. For the external clock to meet the sampling requirement, the ripple-counter must be taken into account. Therefore, it is necessary for T0CKI to have a period of at least 4Tosc (and a small RC delay of 40 ns) divided by the prescaler value. The only requirement on T0CKI high and low time is that they do not violate the minimum pulse width requirement of 10 ns. Refer to parameters 40, 41 and 42 in the electrical specification of the desired device. See Table 17-7.

PIC16F62X

6.3 Timer0 Prescaler

An 8-bit counter is available as a prescaler for the Timer0 module, or as a postscaler for the Watchdog Timer. A prescaler assignment for the Timer0 module means that there is no postscaler for the Watchdog Timer, and vice-versa.

The PSA and PS2:PS0 bits (OPTION<3:0>) determine the prescaler assignment and prescale ratio.

When assigned to the Timer0 module, all instructions writing to the TMR0 register (e.g., CLRF 1, MOVWF 1, BSF 1, x...etc.) will clear the prescaler. When assigned to WDT, a CLRWDT instruction will clear the prescaler along with the Watchdog Timer. The prescaler is not readable or writable.

FIGURE 6-1: BLOCK DIAGRAM OF THE TIMER0/WDT

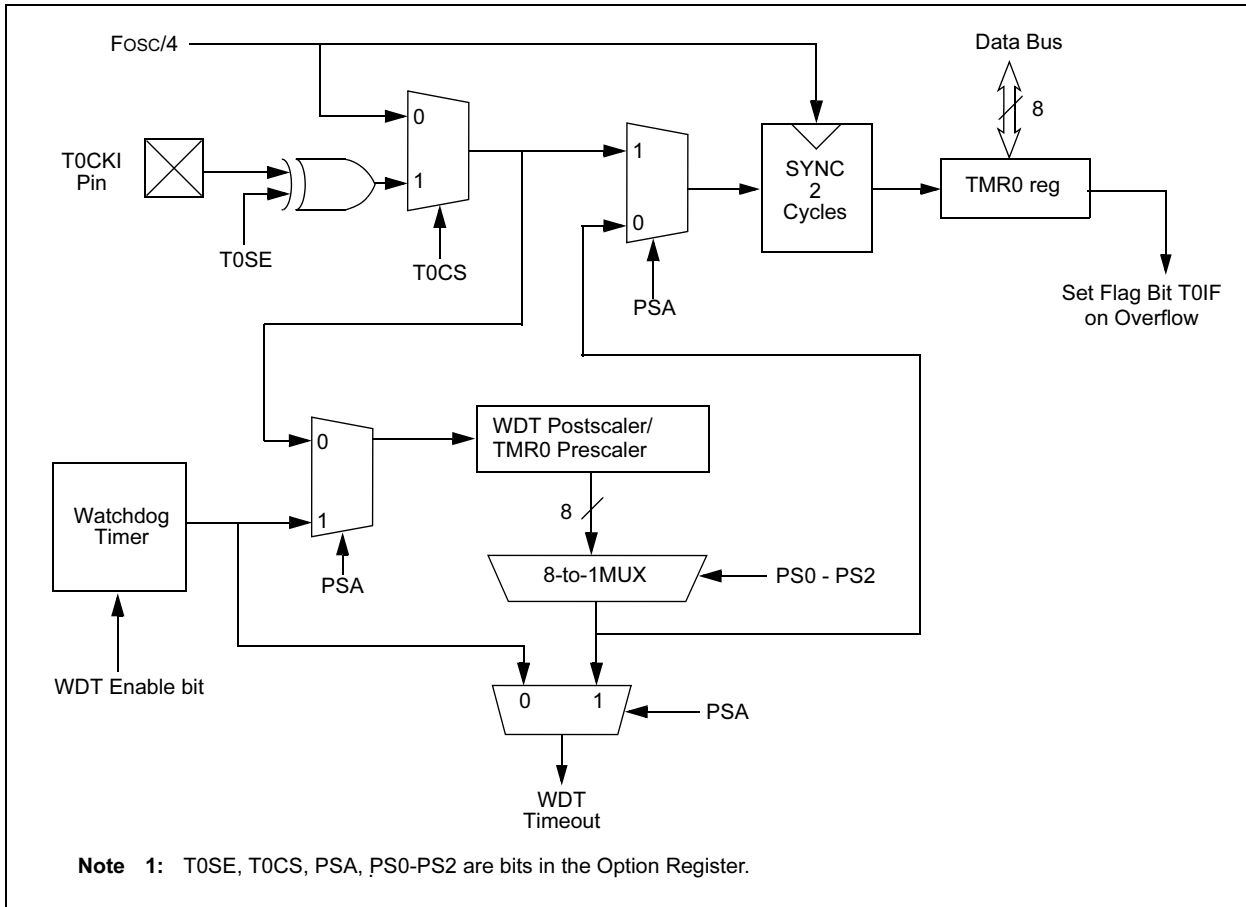

6.3.1 SWITCHING PRESCALER ASSIGNMENT

The prescaler assignment is fully under software control (i.e., it can be changed “on the fly” during program execution). Use the instruction sequences, shown in Example 6-1, when changing the prescaler assignment from Timer0 to WDT, to avoid an unintended device RESET.

EXAMPLE 6-1: CHANGING PRESCALER (TIMER0→WDT)

```
BCF     STATUS, RP0    ;Skip if already in
                        ;Bank 0
CLRWDT                    ;Clear WDT
CLRF     TMR0          ;Clear TMR0 & Prescaler
BSF     STATUS, RP0    ;Bank 1
MOVLW   '00101111'b   ;These 3 lines
                        ;(5, 6, 7)
MOVWF   OPTION_REG     ;are required only
                        ;if desired PS<2:0>
                        ;are
CLRWDT                    ;000 or 001
MOVLW   '00101xxx'b   ;Set Postscaler to
MOVWF   OPTION_REG     ;desired WDT rate
BCF     STATUS, RP0    ;Return to Bank 0
```

To change prescaler from the WDT to the TMR0 module use the sequence shown in Example 6-2. This precaution must be taken even if the WDT is disabled.

EXAMPLE 6-2: CHANGING PRESCALER (WDT→TIMER0)

```
CLRWDT                    ;Clear WDT and
                        ;prescaler
BSF     STATUS, RP0
MOVLW   b'xxxx0xxx'     ;Select TMR0, new
                        ;prescale value and
                        ;clock source
MOVWF   OPTION_REG
BCF     STATUS, RP0
```

TABLE 6-1: REGISTERS ASSOCIATED WITH TIMER0

Address	Name	Bit 7	Bit 6	Bit 5	Bit 4	Bit 3	Bit 2	Bit 1	Bit 0	Value on POR	Value on All Other RESETS
01h	TMR0	Timer0 module register								xxxx xxxx	uuuu uuuu
0Bh/8Bh/ 10Bh/18Bh	INTCON	GIE	PEIE	T0IE	INTE	RBIE	T0IF	INTF	RBIF	0000 000x	0000 000u
81h, 181h	OPTION ⁽²⁾	$\overline{\text{RBP}}\overline{\text{U}}$	INTEDG	T0CS	T0SE	PSA	PS2	PS1	PS0	1111 1111	1111 1111
85h	TRISA	TRISA7	TRISA6	TRISA5	TRISA4	TRISA3	TRISA2	TRISA1	TRISA0	1111 1111	1111 1111

Legend: — = Unimplemented locations, read as '0', u = unchanged, x = unknown

Note 1: Shaded bits are not used by TMR0 module.

2: Option is referred by OPTION_REG in MPLAB.

PIC16F62X

7.0 TIMER1 MODULE

The Timer1 module is a 16-bit timer/counter consisting of two 8-bit registers (TMR1H and TMR1L) which are readable and writable. The TMR1 Register pair (TMR1H:TMR1L) increments from 0000h to FFFFh and rolls over to 0000h. The TMR1 Interrupt, if enabled, is generated on overflow which is latched in interrupt flag bit TMR1IF (PIR1<0>). This interrupt can be enabled/disabled by setting/clearing TMR1 interrupt enable bit TMR1IE (PIE1<0>).

Timer1 can operate in one of two modes:

- As a timer
- As a counter

The Operating mode is determined by the clock select bit, TMR1CS (T1CON<1>).

In Timer mode, Timer1 increments every instruction cycle. In Counter mode, it increments on every rising edge of the external clock input.

Timer1 can be enabled/disabled by setting/clearing control bit TMR1ON (T1CON<0>).

Timer1 also has an internal "RESET input". This RESET can be generated by the CCP module (Section 11.0). Register 7-1 shows the Timer1 Control register.

For the PIC16F627 and PIC16F628, when the Timer1 oscillator is enabled (T1OSCEN is set), the RB7/T1OSI and RB6/T1OSO/T1CKI pins become inputs. That is, the TRISB<7:6> value is ignored.

REGISTER 7-1: T1CON: TIMER1 CONTROL REGISTER (ADDRESS: 10h)

U-0	U-0	R/W-0	R/W-0	R/W-0	R/W-0	R/W-0	R/W-0	
—	—	T1CKPS1	T1CKPS0	T1OSCEN	$\overline{T1SYNC}$	TMR1CS	TMR1ON	
bit 7								bit 0

bit 7-6 **Unimplemented:** Read as '0'

bit 5-4 **T1CKPS1:T1CKPS0:** Timer1 Input Clock Prescale Select bits

11 = 1:8 Prescale value
 10 = 1:4 Prescale value
 01 = 1:2 Prescale value
 00 = 1:1 Prescale value

bit 3 **T1OSCEN:** Timer1 Oscillator Enable Control bit

1 = Oscillator is enabled
 0 = Oscillator is shut off⁽¹⁾

bit 2 **T1SYNC:** Timer1 External Clock Input Synchronization Control bit

TMR1CS = 1

1 = Do not synchronize external clock input
 0 = Synchronize external clock input

TMR1CS = 0

This bit is ignored. Timer1 uses the internal clock when TMR1CS = 0.

bit 1 **TMR1CS:** Timer1 Clock Source Select bit

1 = External clock from pin RB6/T1OSO/T1CKI (on the rising edge)
 0 = Internal clock (Fosc/4)

bit 0 **TMR1ON:** Timer1 On bit

1 = Disables Timer1
 0 = Stops Timer1

Note 1: The oscillator inverter and feedback resistor are turned off to eliminate power drain.

Legend:			
R = Readable bit	W = Writable bit	U = Unimplemented bit, read as '0'	
-n = Value at POR	'1' = Bit is set	'0' = Bit is cleared	x = Bit is unknown

7.1 Timer1 Operation in Timer Mode

Timer mode is selected by clearing the TMR1CS (T1CON<1>) bit. In this mode, the input clock to the timer is $F_{osc}/4$. The synchronize control bit T1SYNC (T1CON<2>) has no effect since the internal clock is always in sync.

7.2 Timer1 Operation in Synchronized Counter Mode

Counter mode is selected by setting bit TMR1CS. In this mode the timer increments on every rising edge of clock input on pin RB7/T1OSI when bit T1OSCEN is set or pin RB6/T1OSO/T1CKI when bit T1OSCEN is cleared.

If T1SYNC is cleared, then the external clock input is synchronized with internal phase clocks. The synchronization is done after the prescaler stage. The prescaler stage is an asynchronous ripple-counter.

In this configuration, during SLEEP mode, Timer1 will not increment even if the external clock is present, since the synchronization circuit is shut off. The prescaler however will continue to increment.

7.2.1 EXTERNAL CLOCK INPUT TIMING FOR SYNCHRONIZED COUNTER MODE

When an external clock input is used for Timer1 in Synchronized Counter mode, it must meet certain requirements. The external clock requirement is due to internal phase clock (T_{osc}) synchronization. Also, there is a delay in the actual incrementing of TMR1 after synchronization.

When the prescaler is 1:1, the external clock input is the same as the prescaler output. The synchronization of T1CKI with the internal phase clocks is accomplished by sampling the prescaler output on the Q2 and Q4 cycles of the internal phase clocks. Therefore, it is necessary for T1CKI to be high for at least $2T_{osc}$ (and a small RC delay of 20 ns) and low for at least $2T_{osc}$ (and a small RC delay of 20 ns). Refer to the appropriate electrical specifications, parameters 45, 46, and 47.

When a prescaler other than 1:1 is used, the external clock input is divided by the asynchronous ripple-counter type prescaler so that the prescaler output is symmetrical. In order for the external clock to meet the sampling requirement, the ripple-counter must be taken into account. Therefore, it is necessary for T1CKI to have a period of at least $4T_{osc}$ (and a small RC delay of 40 ns) divided by the prescaler value. The only requirement on T1CKI high and low time is that they do not violate the minimum pulse width requirements of 10 ns). Refer to the appropriate electrical specifications, parameters 40, 42, 45, 46, and 47.

FIGURE 7-1: TIMER1 BLOCK DIAGRAM

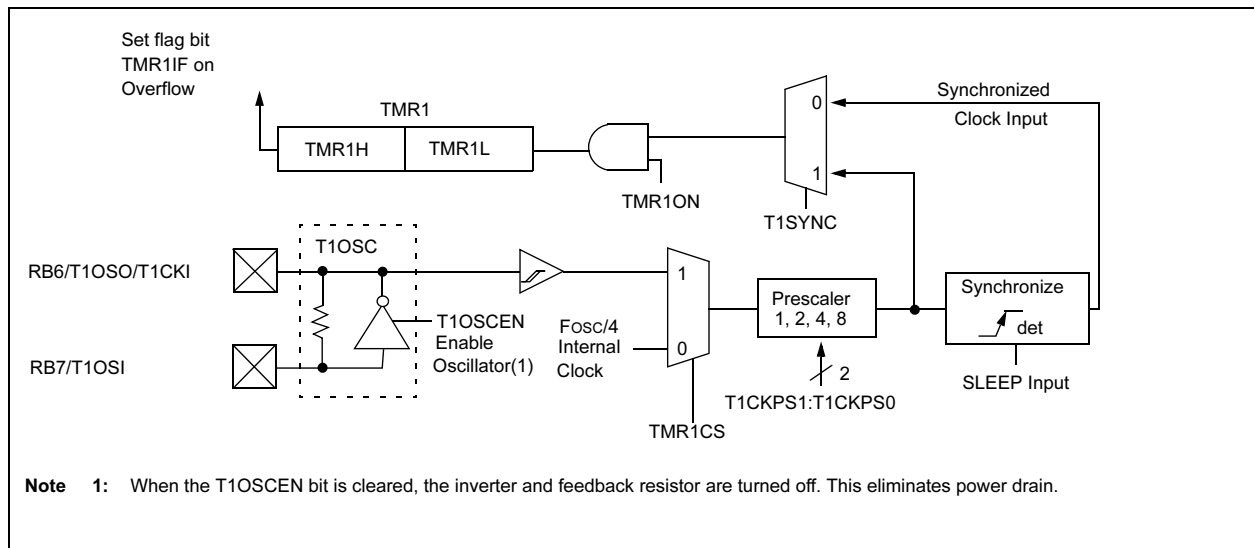

PIC16F62X

7.3 Timer1 Operation in Asynchronous Counter Mode

If control bit $\overline{T1SYNC}$ (T1CON<2>) is set, the external clock input is not synchronized. The timer continues to increment asynchronous to the internal phase clocks. The timer will continue to run during SLEEP and can generate an interrupt on overflow which will wake-up the processor. However, special precautions in software are needed to read/write the timer (Section 7.3.2).

In Asynchronous Counter mode, Timer1 can not be used as a time-base for capture or compare operations.

7.3.1 EXTERNAL CLOCK INPUT TIMING WITH UNSYNCHRONIZED CLOCK

If control bit $\overline{T1SYNC}$ is set, the timer will increment completely asynchronously. The input clock must meet certain minimum high-time and low-time requirements. Refer to the appropriate Electrical Specifications section, Timing Parameters 45, 46, and 47.

7.3.2 READING AND WRITING TIMER1 IN ASYNCHRONOUS COUNTER MODE

Reading TMR1H or TMR1L while the timer is running, from an external asynchronous clock, will ensure a valid read (taken care of in hardware). However, the user should keep in mind that reading the 16-bit timer in two 8-bit values itself poses certain problems since the timer may overflow between the reads.

For writes, it is recommended that the user simply stop the timer and write the desired values. A write contention may occur by writing to the timer registers while the register is incrementing. This may produce an unpredictable value in the timer register.

Reading the 16-bit value requires some care. Example 7-1 is an example routine to read the 16-bit timer value. This is useful if the timer cannot be stopped.

EXAMPLE 7-1: READING A 16-BIT FREE-RUNNING TIMER

```
; All interrupts are disabled
MOVWF TMR1H, W ;Read high byte
MOVWF TMPH ;
MOVWF TMR1L, W ;Read low byte
MOVWF TMPL ;
MOVWF TMR1H, W ;Read high byte
SUBWF TMPH, W ;Sub 1st read
; with 2nd read
BTFSC STATUS,Z ;Is result = 0
GOTO CONTINUE ;Good 16-bit read
;
; TMR1L may have rolled over between the read
; of the high and low bytes. Reading the high
; and low bytes now will read a good value.
;
MOVWF TMR1H, W ;Read high byte
MOVWF TMPH ;
MOVWF TMR1L, W ;Read low byte
MOVWF TMPL ;
; Re-enable the Interrupts (if required)
CONTINUE ;Continue with your code
```

7.4 Timer1 Oscillator

A crystal oscillator circuit is built in between pins T1OSI (input) and T1OSO (amplifier output). It is enabled by setting control bit T1OSCEN (T1CON<3>). The oscillator is a low power oscillator rated up to 200 kHz. It will continue to run during SLEEP. It is primarily intended for a 32 kHz crystal. Table 7-1 shows the capacitor selection for the Timer1 oscillator.

The Timer1 oscillator is identical to the LP oscillator. The user must provide a software time delay to ensure proper oscillator start-up.

TABLE 7-1: CAPACITOR SELECTION FOR THE TIMER1 OSCILLATOR

Osc Type	Freq	C1	C2
LP	32 kHz	33 pF	33 pF
	100 kHz	15 pF	15 pF
	200 kHz	15 pF	15 pF
Note 1: These values are for design guidance only. Consult AN826 (DS00826A) for further information on Crystal/Capacitor Selection.			

7.5 Resetting Timer1 Using a CCP Trigger Output

If the CCP1 module is configured in Compare mode to generate a “special event trigger” (CCP1M3:CCP1M0 = 1011), this signal will reset Timer1.

Note: The special event triggers from the CCP1 module will not set interrupt flag bit TMR1IF (PIR1<0>).

Timer1 must be configured for either Timer or Synchronized Counter mode to take advantage of this feature. If Timer1 is running in Asynchronous Counter mode, this RESET operation may not work.

In the event that a write to Timer1 coincides with a special event trigger from CCP1, the write will take precedence.

In this mode of operation, the CCPRxH:CCPRxL registers pair effectively becomes the period register for Timer1.

7.6 Resetting of Timer1 Register Pair (TMR1H, TMR1L)

TMR1H and TMR1L registers are not reset to 00h on a POR or any other RESET except by the CCP1 special event triggers.

T1CON register is reset to 00h on a Power-on Reset or a Brown-out Reset, which shuts off the timer and leaves a 1:1 prescale. In all other RESETS, the register is unaffected.

7.7 Timer1 Prescaler

The prescaler counter is cleared on writes to the TMR1H or TMR1L registers.

TABLE 7-2: REGISTERS ASSOCIATED WITH TIMER1 AS A TIMER/COUNTER

Address	Name	Bit 7	Bit 6	Bit 5	Bit 4	Bit 3	Bit 2	Bit 1	Bit 0	Value on POR	Value on all other RESETS
0Bh/8Bh/10Bh/18Bh	INTCON	GIE	PEIE	T0IE	INTE	RBIE	T0IF	INTF	RBIF	0000 000x	0000 000u
0Ch	PIR1	EEIF	CMIF	RCIF	TXIF	—	CCP1IF	TMR2IF	TMR1IF	0000 -000	0000 -000
8Ch	PIE1	EEIE	CMIE	RCIE	TXIE	—	CCP1IE	TMR2IE	TMR1IE	0000 -000	0000 -000
0Eh	TMR1L	Holding register for the Least Significant Byte of the 16-bit TMR1 register								xxxx xxxx	uuuu uuuu
0Fh	TMR1H	Holding register for the Most Significant Byte of the 16-bit TMR1 register								xxxx xxxx	uuuu uuuu
10h	T1CON	—	—	T1CKPS1	T1CKPS0	T1OSCEN	T1SYNC	TMR1CS	TMR1ON	--00 0000	--uu uuuu

Legend: x = unknown, u = unchanged, - = unimplemented read as '0'. Shaded cells are not used by the Timer1 module.

PIC16F62X

8.0 TIMER2 MODULE

Timer2 is an 8-bit timer with a prescaler and a postscaler. It can be used as the PWM time-base for PWM mode of the CCP module. The TMR2 register is readable and writable, and is cleared on any device RESET.

The input clock ($F_{osc}/4$) has a prescale option of 1:1, 1:4 or 1:16, selected by control bits T2CKPS1:T2CKPS0 (T2CON<1:0>).

The Timer2 module has an 8-bit Period Register PR2. Timer2 increments from 00h until it matches PR2 and then resets to 00h on the next increment cycle. PR2 is a readable and writable register. The PR2 register is initialized to FFh upon RESET.

The match output of TMR2 goes through a 4-bit postscaler (which gives a 1:1 to 1:16 scaling inclusive) to generate a TMR2 interrupt (latched in flag bit TMR2IF, (PIR1<1>)).

Timer2 can be shut off by clearing control bit TMR2ON (T2CON<2>) to minimize power consumption.

Register 8-1 shows the Timer2 Control register.

8.1 Timer2 Prescaler and Postscaler

The prescaler and postscaler counters are cleared when any of the following occurs:

- A write to the TMR2 register
- A write to the T2CON register
- Any device RESET (Power-on Reset, \overline{MCLR} Reset, Watchdog Timer Reset, or Brown-out Reset)

TMR2 is not cleared when T2CON is written.

8.2 Output of TMR2

The output of TMR2 (before the postscaler) is fed to the Synchronous Serial Port module which optionally uses it to generate shift clock.

FIGURE 8-1: TIMER2 BLOCK DIAGRAM

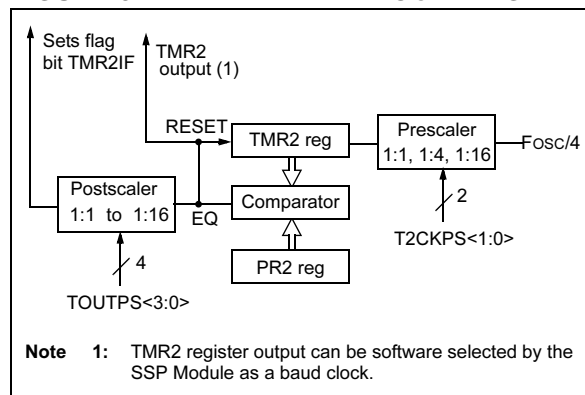

REGISTER 8-1: T2CON: TIMER CONTROL REGISTER (ADDRESS: 12h)

U-0	R/W-0	R/W-0	R/W-0	R/W-0	R/W-0	R/W-0	R/W-0
—	TOUTPS3	TOUTPS2	TOUTPS1	TOUTPS0	TMR2ON	T2CKPS1	T2CKPS0
bit 7							bit 0

bit 7 **Unimplemented:** Read as '0'

bit 6-3 **TOUTPS3:TOUTPS0:** Timer2 Output Postscale Select bits

0000 = 1:1 Postscale Value

0001 = 1:2 Postscale Value

•

•

•

1111 = 1:16 Postscale

bit 2 **TMR2ON:** Timer2 On bit

1 = Timer2 is on

0 = Timer2 is off

bit 1-0 **T2CKPS1:T2CKPS0:** Timer2 Clock Prescale Select bits

00 = 1:1 Prescaler Value

01 = 1:4 Prescaler Value

1x = 1:16 Prescaler Value

Legend:

R = Readable bit

W = Writable bit

U = Unimplemented bit, read as '0'

-n = Value at POR

'1' = Bit is set

'0' = Bit is cleared

x = Bit is unknown

TABLE 8-1: REGISTERS ASSOCIATED WITH TIMER2 AS A TIMER/COUNTER

Address	Name	Bit 7	Bit 6	Bit 5	Bit 4	Bit 3	Bit 2	Bit 1	Bit 0	Value on POR	Value on all other RESETS
0Bh/8Bh/ 10Bh/18Bh	INTCON	GIE	PEIE	TOIE	INTE	RBIE	TOIF	INTF	RBIF	0000 000x	0000 000u
0Ch	PIR1	EEIF	CMIF	RCIF	TXIF	—	CCP1IF	TMR2IF	TMR1IF	0000 -000	0000 -000
8Ch	PIE1	EEIE	CMIE	RCIE	TXIE	—	CCP1IE	TMR2IE	TMR1IE	0000 -000	0000 -000
11h	TMR2	Timer2 module's register								0000 0000	0000 0000
12h	T2CON	—	TOUTPS3	TOUTPS2	TOUTPS1	TOUTPS0	TMR2ON	T2CKPS1	T2CKPS0	-000 0000	-000 0000
92h	PR2	Timer2 Period Register								1111 1111	1111 1111

Legend: x = unknown, u = unchanged, - = unimplemented read as '0'. Shaded cells are not used by the Timer2 module.

PIC16F62X

NOTES:

9.0 COMPARATOR MODULE

The Comparator module contains two analog comparators. The inputs to the comparators are multiplexed with the RA0 through RA3 pins. The On-chip Voltage Reference (Section 10.0) can also be an input to the comparators.

The CMCON register, shown in Register 9-1, controls the comparator input and output multiplexers. A block diagram of the comparator is shown in Figure 9-1.

REGISTER 9-1: CMCON REGISTER (ADDRESS: 01Fh)

R-0	R-0	R/W-0	R/W-0	R/W-0	R/W-0	R/W-0	R/W-0
C2OUT	C1OUT	C2INV	C1INV	CIS	CM2	CM1	CM0
bit 7						bit 0	

bit 7	<p>C2OUT: Comparator 2 Output</p> <p><u>When C2INV = 0:</u></p> <p>1 = C2 VIN+ > C2 VIN-</p> <p>0 = C2 VIN+ < C2 VIN-</p> <p><u>When C2INV = 1:</u></p> <p>1 = C2 VIN+ < C2 VIN-</p> <p>0 = C2 VIN+ > C2 VIN-</p>
bit 6	<p>C1OUT: Comparator 1 Output</p> <p><u>When C1INV = 0:</u></p> <p>1 = C1 VIN+ > C1 VIN-</p> <p>0 = C1 VIN+ < C1 VIN-</p> <p><u>When C1INV = 1:</u></p> <p>1 = C1 VIN+ < C1 VIN-</p> <p>0 = C1 VIN+ > C1 VIN-</p>
bit 5	<p>C2INV: Comparator 2 Output Inversion</p> <p>1 = C2 Output inverted</p> <p>0 = C2 Output not inverted</p>
bit 4	<p>C1INV: Comparator 1 Output Inversion</p> <p>1 = C1 Output inverted</p> <p>0 = C1 Output not inverted</p>
bit 3	<p>CIS: Comparator Input Switch</p> <p><u>When CM2:CM0 = 001</u></p> <p>Then:</p> <p>1 = C1 VIN- connects to RA3</p> <p>0 = C1 VIN- connects to RA0</p> <p><u>When CM2:CM0 = 010</u></p> <p>Then:</p> <p>1 = C1 VIN- connects to RA3</p> <p> C2 VIN- connects to RA2</p> <p>0 = C1 VIN- connects to RA0</p> <p> C2 VIN- connects to RA1</p>
bit 2-0	<p>CM2:CM0: Comparator Mode</p> <p>Figure 9-1 shows the Comparator modes and CM2:CM0 bit settings</p>

Legend:			
R = Readable bit	W = Writable bit	U = Unimplemented bit, read as '0'	
-n = Value at POR	'1' = Bit is set	'0' = Bit is cleared	x = Bit is unknown

PIC16F62X

9.1 Comparator Configuration

There are eight modes of operation for the comparators. The CMCON register is used to select the mode. Figure 9-1 shows the eight possible modes. The TRISA register controls the data direction of the comparator pins for each mode. If the Comparator

mode is changed, the comparator output level may not be valid for the specified mode change delay shown in Table 17-1.

Note: Comparator interrupts should be disabled during a Comparator mode change otherwise a false interrupt may occur.

FIGURE 9-1: COMPARATOR I/O OPERATING MODES

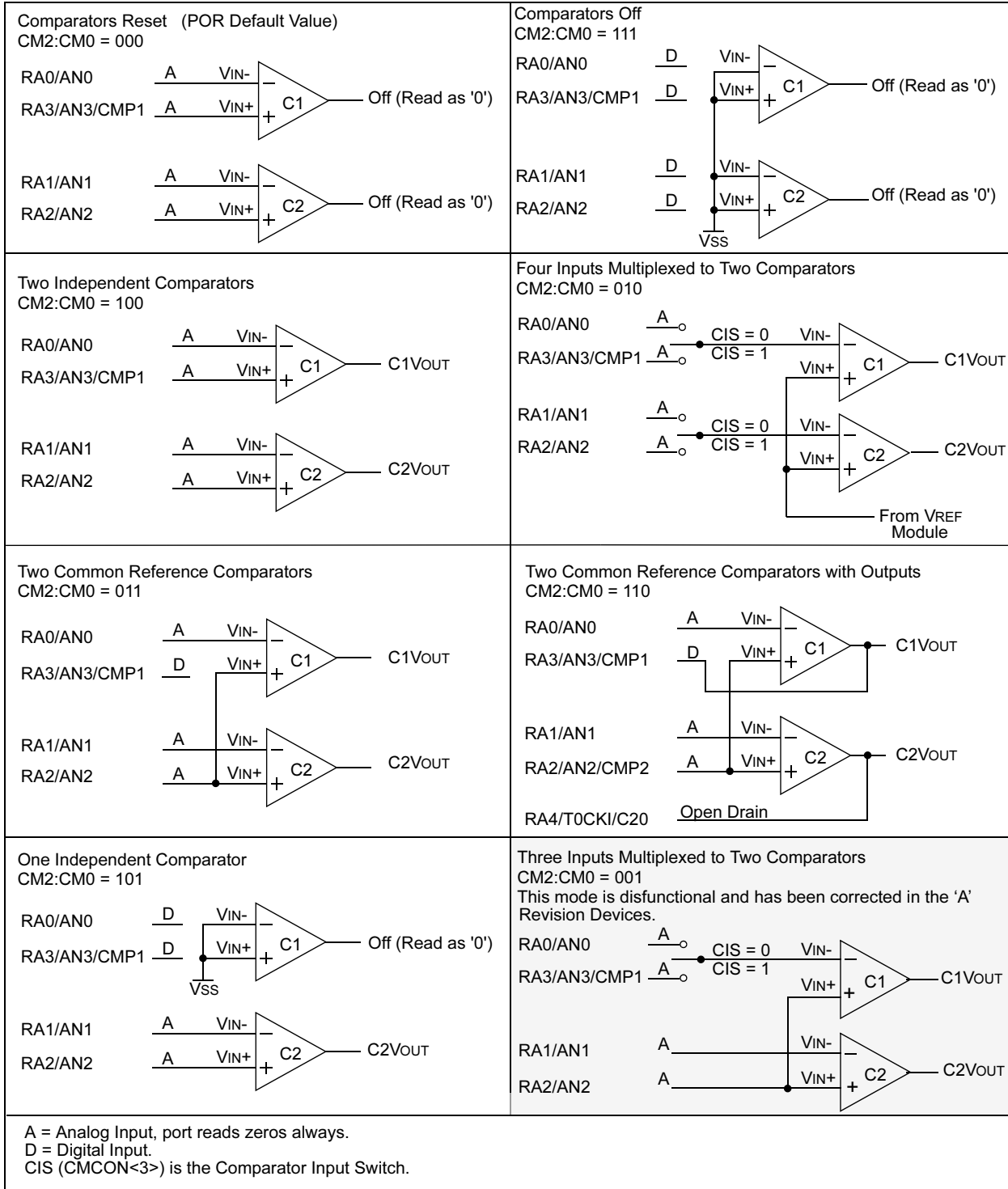

The code example in Example 9-1 depicts the steps required to configure the Comparator module. RA3 and RA4 are configured as digital output. RA0 and RA1 are configured as the V- inputs and RA2 as the V+ input to both comparators.

EXAMPLE 9-1: INITIALIZING COMPARATOR MODULE

```

FLAG_REG EQU      0X20
CLRF   FLAG_REG   ;Init flag register
CLRF   PORTA      ;Init PORTA
MOVF   CMCON, W   ;Load comparator bits
ANDLW  0xC0       ;Mask comparator bits
IORWF  FLAG_REG,F ;Store bits in flag register
MOVLW  0x03       ;Init comparator mode
MOVWF  CMCON      ;CM<2:0> = 011
BSF    STATUS,RP0 ;Select Bank1
MOVLW  0x07       ;Initialize data direction
MOVWF  TRISA      ;Set RA<2:0> as inputs
                          ;RA<4:3> as outputs
                          ;TRISA<7:5> always read '0'
BCF    STATUS,RP0 ;Select Bank 0
CALL   DELAY10    ;10µs delay
MOVF   CMCON,F    ;Read CMCON to end change condition
BCF    PIR1,CMIF  ;Clear pending interrupts
BSF    STATUS,RP0 ;Select Bank 1
BSF    PIE1,CMIE  ;Enable comparator interrupts
BCF    STATUS,RP0 ;Select Bank 0
BSF    INTCON,PEIE ;Enable peripheral interrupts
BSF    INTCON,GIE ;Global interrupt enable
    
```

9.2 Comparator Operation

A single comparator is shown in Figure 9-2 along with the relationship between the analog input levels and the digital output. When the analog input at VIN+ is less than the analog input VIN-, the output of the comparator is a digital low level. When the analog input at VIN+ is greater than the analog input VIN-, the output of the comparator is a digital high level. The shaded areas of the output of the comparator in Figure 9-2 represent the uncertainty due to input offsets and response time.

9.3 Comparator Reference

An external or internal reference signal may be used depending on the Comparator Operating mode. The analog signal that is present at VIN- is compared to the signal at VIN+, and the digital output of the comparator is adjusted accordingly (Figure 9-2).

FIGURE 9-2: SINGLE COMPARATOR

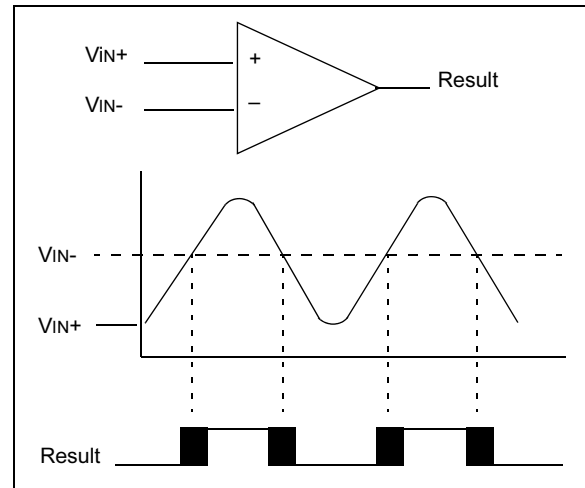

9.3.1 EXTERNAL REFERENCE SIGNAL

When external voltage references are used, the comparator module can be configured to have the comparators operate from the same or different reference sources. However, threshold detector applications may require the same reference. The reference signal must be between VSS and VDD, and can be applied to either pin of the comparator(s).

9.3.2 INTERNAL REFERENCE SIGNAL

The Comparator module also allows the selection of an internally generated voltage reference for the comparators. Section 10.0, Voltage Reference Manual, contains a detailed description of the Voltage Reference module that provides this signal. The internal reference signal is used when the comparators are in mode CM<2:0>=010 (Figure 9-1). In this mode, the internal voltage reference is applied to the VIN+ pin of both comparators.

9.4 Comparator Response Time

Response time is the minimum time, after selecting a new reference voltage or input source, before the comparator output is ensured to have a valid level. If the internal reference is changed, the maximum delay of the internal voltage reference must be considered when using the comparator outputs. Otherwise the maximum delay of the comparators should be used (Table 17-1).

PIC16F62X

9.5 Comparator Outputs

The comparator outputs are read through the CMCON register. These bits are read only. The comparator outputs may also be directly output to the RA3 and RA4 I/O pins. When the $CM\langle 2:0 \rangle = 110$, multiplexors in the output path of the RA3 and RA4/T0CK1 pins will switch and the output of each pin will be the unsynchronized output of the comparator. The uncertainty of each of the comparators is related to the input offset voltage and the response time given in the specifications. Figure 9-3 shows the comparator output block diagram.

The TRISA bits will still function as an output enable/disable for the RA3 and RA4/T0CK1 pins while in this mode.

- Note 1:** When reading the PORT register, all pins configured as analog inputs will read as a '0'. Pins configured as digital inputs will convert an analog input according to the Schmitt Trigger input specification.
- 2:** Analog levels on any pin that is defined as a digital input may cause the input buffer to consume more current than is specified.

FIGURE 9-3: COMPARATOR OUTPUT BLOCK DIAGRAM

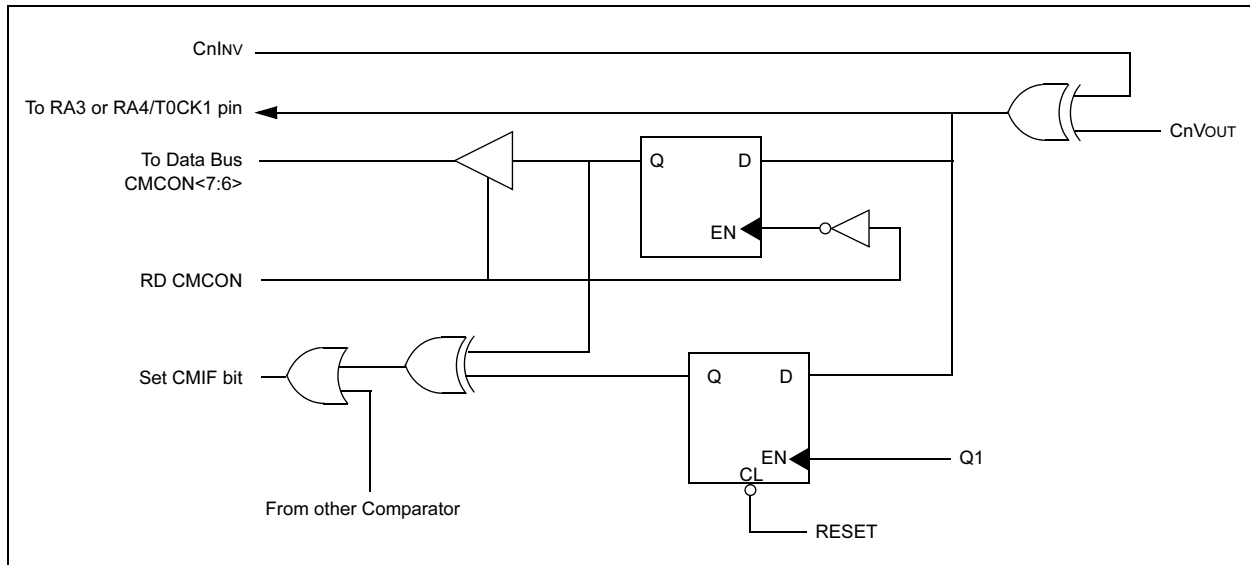

9.6 Comparator Interrupts

The Comparator Interrupt flag is set whenever there is a change in the output value of either comparator. Software will need to maintain information about the status of the output bits, as read from CMCON<7:6>, to determine the actual change that has occurred. The CMIF bit, PIR1<6>, is the Comparator Interrupt Flag. The CMIF bit must be RESET by clearing '0'. Since it is also possible to write a '1' to this register, a simulated interrupt may be initiated.

The CMIE bit (PIE1<6>) and the PEIE bit (INTCON<6>) must be set to enable the interrupt. In addition, the GIE bit must also be set. If any of these bits are clear, the interrupt is not enabled, though the CMIF bit will still be set if an interrupt condition occurs.

Note: If a change in the CMCON register (C1OUT or C2OUT) should occur when a read operation is being executed (start of the Q2 cycle), then the CMIF (PIR1<6>) interrupt flag may not get set.

The user, in the interrupt service routine, can clear the interrupt in the following manner:

- a) Any write or read of CMCON. This will end the mismatch condition.
- b) Clear flag bit CMIF.

A mismatch condition will continue to set flag bit CMIF. Reading CMCON will end the mismatch condition, and allow flag bit CMIF to be cleared.

9.7 Comparator Operation During SLEEP

When a comparator is active and the device is placed in SLEEP mode, the comparator remains active and the interrupt is functional if enabled. This interrupt will wake-up the device from SLEEP mode when enabled. While the comparator is powered-up, higher SLEEP currents than shown in the power-down current specification will occur. Each comparator that is operational will consume additional current as shown in the comparator specifications. To minimize power consumption while in SLEEP mode, turn off the comparators, CM<2:0> = 111, before entering SLEEP. If the device wakes-up from SLEEP, the contents of the CMCON register are not affected.

9.8 Effects of a RESET

A device RESET forces the CMCON register to its RESET state. This forces the Comparator module to be in the comparator RESET mode, CM2:CM0 = 000. This ensures that all potential inputs are analog inputs. Device current is minimized when analog inputs are present at RESET time. The comparators will be powered-down during the RESET interval.

9.9 Analog Input Connection Considerations

A simplified circuit for an analog input is shown in Figure 9-4. Since the analog pins are connected to a digital output, they have reverse biased diodes to VDD and VSS. The analog input therefore, must be between VSS and VDD. If the input voltage deviates from this range by more than 0.6V in either direction, one of the diodes is forward biased and a latchup may occur. A maximum source impedance of 10 kΩ is recommended for the analog sources. Any external component connected to an analog input pin, such as a capacitor or a Zener diode, should have very little leakage current.

PIC16F62X

FIGURE 9-4: ANALOG INPUT MODE

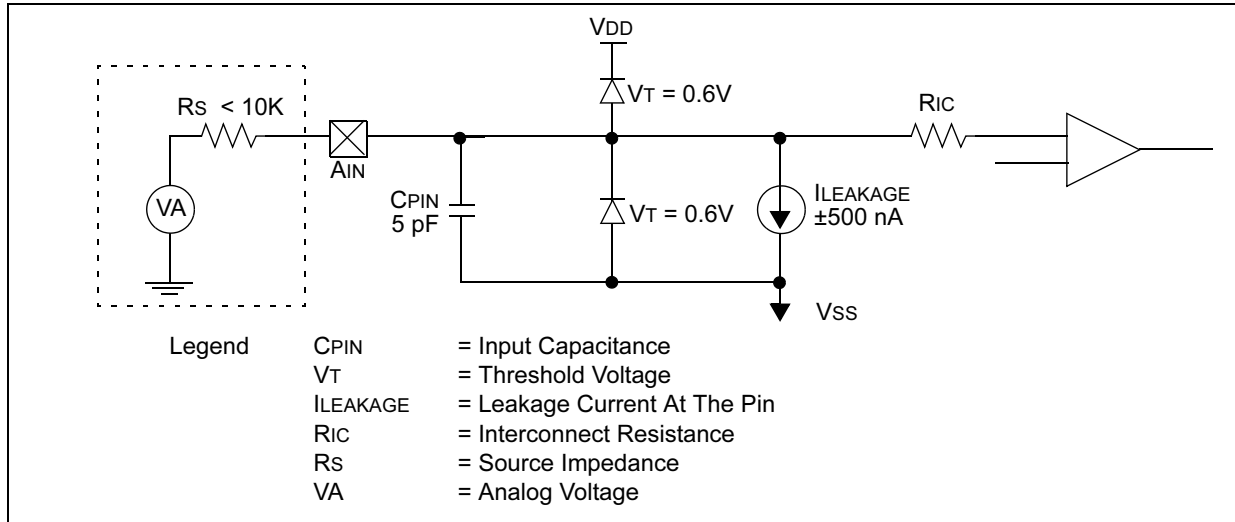

TABLE 9-1: REGISTERS ASSOCIATED WITH COMPARATOR MODULE

Address	Name	Bit 7	Bit 6	Bit 5	Bit 4	Bit 3	Bit 2	Bit 1	Bit 0	Value on POR	Value on All Other RESETS
1Fh	CMCON	C2OUT	C1OUT	C2INV	C1NV	CIS	CM2	CM1	CM0	0000 0000	0000 0000
0Bh/8Bh/ 10Bh/18Bh	INTCON	GIE	PEIE	T0IE	INTE	RBIE	T0IF	INTF	RBIF	0000 000x	0000 000u
0Ch	PIR1	EEIF	CMIF	RCIF	TXIF	—	CCP1IF	TMR2IF	TMR1IF	0000 -000	0000 -000
8Ch	PIE1	EEIE	CMIE	RCIE	TXIE	—	CCP1IE	TMR2IE	TMR1IE	0000 -000	0000 -000
85h	TRISA	TRISA7	TRISA6	TRISA5	TRISA4	TRISA3	TRISA2	TRISA1	TRISA0	1111 1111	1111 1111

Legend: x = Unknown, u = Unchanged, - = Unimplemented, read as '0'

10.0 VOLTAGE REFERENCE MODULE

The Voltage Reference is a 16-tap resistor ladder network that provides a selectable voltage reference. The resistor ladder is segmented to provide two ranges of VREF values and has a power-down function to conserve power when the reference is not being used. The VRCON register controls the operation of the reference as shown in Figure 10-1. The block diagram is given in Figure 10-1.

10.1 Configuring the Voltage Reference

The Voltage Reference can output 16 distinct voltage levels for each range.

The equations used to calculate the output of the Voltage Reference are as follows:

$$\text{if } VRR = 1: VREF = (VR<3:0>/24) \times VDD$$

$$\text{if } VRR = 0: VREF = (VDD \times 1/4) + (VR<3:0>/32) \times VDD$$

The setting time of the Voltage Reference must be considered when changing the VREF output (Table 17-2). Example 10-1 shows an example of how to configure the Voltage Reference for an output voltage of 1.25V with VDD = 5.0V.

REGISTER 10-1: VRCON REGISTER (ADDRESS: 9Fh)

R/W-0	R/W-0	R/W-0	U-0	R/W-0	R/W-0	R/W-0	R/W-0	
VREN	VROE	VRR	—	VR3	VR2	VR1	VR0	
bit 7								bit 0

- bit 7 **VREN:** VREF Enable
1 = VREF circuit powered on
0 = VREF circuit powered down, no IDD drain
- bit 6 **VROE:** VREF Output Enable
1 = VREF is output on RA2 pin
0 = VREF is disconnected from RA2 pin
- bit 5 **VRR:** VREF Range selection
1 = Low Range
0 = High Range
- bit 4 **Unimplemented:** Read as '0'
- bit 3-0 **VR<3:0>:** VREF value selection $0 \leq VR [3:0] \leq 15$
When $VRR = 1$: $VREF = (VR<3:0>/24) \times VDD$
When $VRR = 0$: $VREF = 1/4 \times VDD + (VR<3:0>/32) \times VDD$

Legend:

R = Readable bit W = Writable bit U = Unimplemented bit, read as '0'
-n = Value at POR '1' = Bit is set '0' = Bit is cleared x = Bit is unknown

FIGURE 10-1: VOLTAGE REFERENCE BLOCK DIAGRAM

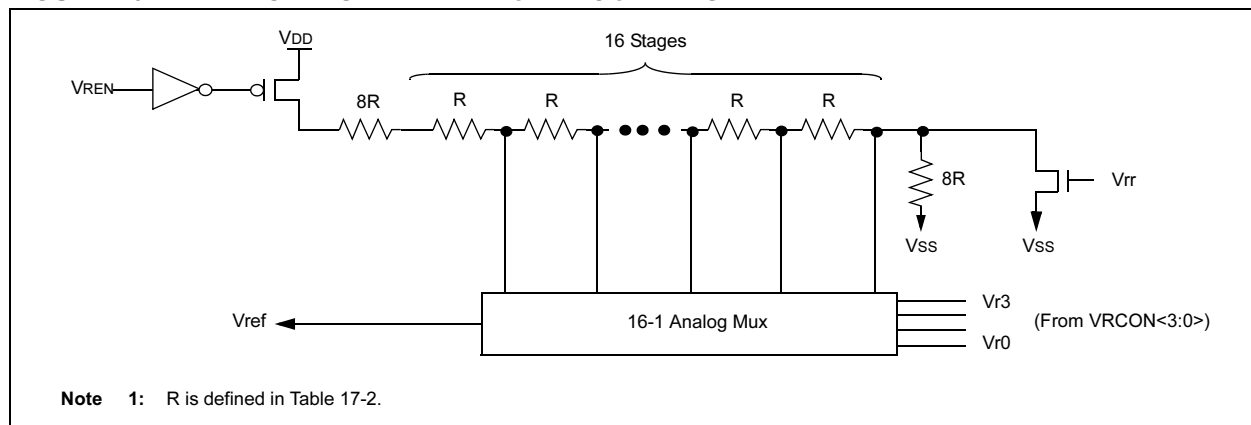

PIC16F62X

EXAMPLE 10-1: VOLTAGE REFERENCE CONFIGURATION

```

MOVLW    0x02        ; 4 Inputs Muxed
MOVWF    CMCON       ; to 2 comps.
BSF      STATUS,RP0  ; go to Bank 1
MOVLW    0x07        ; RA3-RA0 are
MOVWF    TRISA       ; outputs
MOVLW    0xA6        ; enable VREF
MOVWF    VRCON       ; low range
                        ; set VR<3:0>=6
BCF      STATUS,RP0  ; go to Bank 0
CALL     DELAY10     ; 10µs delay
    
```

10.2 Voltage Reference Accuracy/Error

The full range of VSS to VDD cannot be realized due to the construction of the module. The transistors on the top and bottom of the resistor ladder network (Figure 10-1) keep VREF from approaching VSS or VDD. The Voltage Reference is VDD derived and therefore, the VREF output changes with fluctuations in VDD. The tested absolute accuracy of the Voltage Reference can be found in Table 17-2.

10.3 Operation During SLEEP

When the device wakes-up from SLEEP through an interrupt or a Watchdog Timer timeout, the contents of the VRCON register are not affected. To minimize current consumption in SLEEP mode, the Voltage Reference should be disabled.

10.4 Effects of a RESET

A device RESET disables the Voltage Reference by clearing bit VREN (VRCON<7>). This RESET also disconnects the reference from the RA2 pin by clearing bit VROE (VRCON<6>) and selects the high voltage range by clearing bit VRR (VRCON<5>). The VREF value select bits, VRCON<3:0>, are also cleared.

10.5 Connection Considerations

The Voltage Reference module operates independently of the Comparator module. The output of the reference generator may be connected to the RA2 pin if the TRISA<2> bit is set and the VROE bit, VRCON<6>, is set. Enabling the Voltage Reference output onto the RA2 pin with an input signal present will increase current consumption. Connecting RA2 as a digital output with VREF enabled will also increase current consumption.

The RA2 pin can be used as a simple D/A output with limited drive capability. Due to the limited drive capability, a buffer must be used in conjunction with the Voltage Reference output for external connections to VREF. Figure 10-2 shows an example buffering technique.

FIGURE 10-2: VOLTAGE REFERENCE OUTPUT BUFFER EXAMPLE

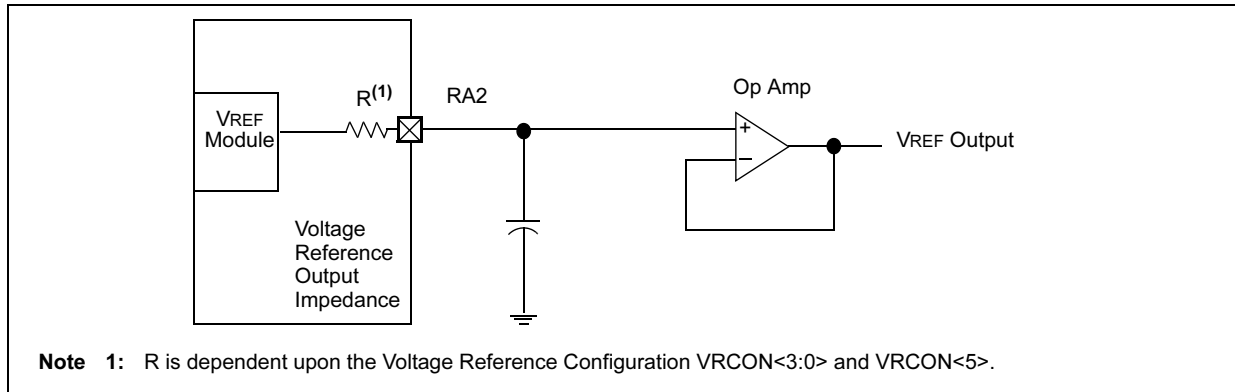

TABLE 10-1: REGISTERS ASSOCIATED WITH VOLTAGE REFERENCE

Address	Name	Bit 7	Bit 6	Bit 5	Bit 4	Bit 3	Bit 2	Bit 1	Bit 0	Value On POR	Value On All Other RESETS
9Fh	VRCON	VREN	VROE	VRR	—	VR3	VR2	VR1	VR0	000- 0000	000- 0000
1Fh	CMCON	C2OUT	C1OUT	C2INV	C1INV	CIS	CM2	CM1	CM0	0000 0000	0000 0000
85h	TRISA	TRISA7	TRISA6	TRISA5	TRISA4	TRISA3	TRISA2	TRISA1	TRISA0	1111 1111	1111 1111

Note 1: — = Unimplemented, read as '0'.

11.0 CAPTURE/COMPARE/PWM (CCP) MODULE

The CCP (Capture/Compare/PWM) module contains a 16-bit register which can operate as a 16-bit capture register, as a 16-bit compare register or as a PWM master/slave Duty Cycle register. Table 11-1 shows the timer resources of the CCP Module modes.

TABLE 11-1: CCP MODE - TIMER RESOURCE

CCP Mode	Timer Resource
Capture	Timer1
Compare	Timer1
PWM	Timer2

CCP1 Module

Capture/Compare/PWM Register1 (CCPR1) is comprised of two 8-bit registers: CCPR1L (low byte) and CCPR1H (high byte). The CCP1CON register controls the operation of CCP1. All are readable and writable.

Additional information on the CCP module is available in the PICmicro™ Mid-Range Reference Manual, (DS33023).

REGISTER 11-1: CCP1CON REGISTER (ADDRESS: 17h)

U-0	U-0	R/W-0	R/W-0	R/W-0	R/W-0	R/W-0	R/W-0	
—	—	CCP1X	CCP1Y	CCP1M3	CCP1M2	CCP1M1	CCP1M0	
bit 7								bit 0

bit 7-6 **Unimplemented:** Read as '0'

bit 5-4 **CCP1X:CCP1Y:** PWM Least Significant bits

Capture Mode: Unused

Compare Mode: Unused

PWM Mode: These bits are the two LSbs of the PWM duty cycle. The eight MSBs are found in CCPRxL.

bit 3-0 **CCP1M3:CCP1M0:** CCPx Mode Select bits

0000 = Capture/Compare/PWM off (resets CCP1 module)

0100 = Capture mode, every falling edge

0101 = Capture mode, every rising edge

0110 = Capture mode, every 4th rising edge

0111 = Capture mode, every 16th rising edge

1000 = Compare mode, set output on match (CCP1IF bit is set)

1001 = Compare mode, clear output on match (CCP1IF bit is set)

1010 = Compare mode, generate software interrupt on match (CCP1IF bit is set, CCP1 pin is unaffected)

1011 = Compare mode, trigger special event (CCP1IF bit is set; CCP1 resets TMR1)

11xx = PWM mode

Legend:

R = Readable bit

W = Writable bit

U = Unimplemented bit, read as '0'

-n = Value at POR

'1' = Bit is set

'0' = Bit is cleared

x = Bit is unknown

PIC16F62X

11.1 Capture Mode

In Capture mode, CCPR1H:CCPR1L captures the 16-bit value of the TMR1 register when an event occurs on pin RB3/CCP1. An event is defined as:

- Every falling edge
- Every rising edge
- Every 4th rising edge
- Every 16th rising edge

An event is selected by control bits CCP1M3:CCP1M0 (CCP1CON<3:0>). When a capture is made, the Interrupt Request Flag bit CCP1IF (PIR1<2>) is set. It must be cleared in software. If another capture occurs before the value in register CCPR1 is read, the old captured value will be lost.

11.1.1 CCP PIN CONFIGURATION

In Capture mode, the RB3/CCP1 pin should be configured as an input by setting the TRISB<3> bit.

Note: If the RB3/CCP1 is configured as an output, a write to the port can cause a capture condition.

TABLE 11-2: CAPTURE MODE OPERATION BLOCK DIAGRAM

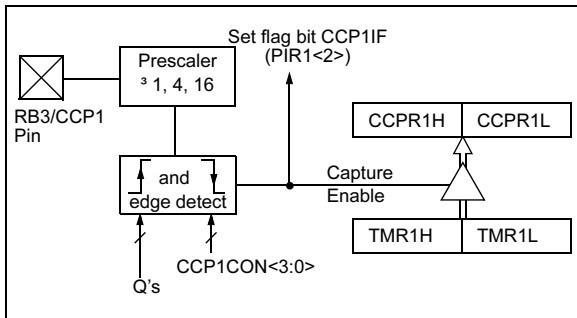

11.1.2 TIMER1 MODE SELECTION

Timer1 must be running in Timer mode or Synchronized Counter mode for the CCP module to use the capture feature. In Asynchronous Counter mode, the capture operation may not work.

11.1.3 SOFTWARE INTERRUPT

When the Capture mode is changed, a false capture interrupt may be generated. The user should keep bit CCP1IE (PIE1<2>) clear to avoid false interrupts and should clear the flag bit CCP1IF following any such change in Operating mode.

11.1.4 CCP PRESCALER

There are four prescaler settings, specified by bits CCP1M3:CCP1M0. Whenever the CCP module is turned off, or the CCP module is not in Capture mode, the prescaler counter is cleared. This means that any RESET will clear the prescaler counter.

Switching from one capture prescaler to another may generate an interrupt. Also, the prescaler counter will not be cleared, therefore the first capture may be from a non-zero prescaler. Example 11-1 shows the recommended method for switching between capture prescalers. This example also clears the prescaler counter and will not generate the “false” interrupt.

EXAMPLE 11-1: CHANGING BETWEEN CAPTURE PRESCALERS

```
CLRF   CCP1CON      ;Turn CCP module off
MOVLW  NEW_CAPT_PS  ;Load the W reg with
                        ; the new prescaler
                        ; mode value and CCP ON
MOVWF  CCP1CON      ;Load CCP1CON with this
                        ; value
```

11.2 Compare Mode

In Compare mode, the 16-bit CCPR1 register value is constantly compared against the TMR1 register pair value. When a match occurs, the RB3/CCP1 pin is:

- Driven High
- Driven Low
- Remains Unchanged

The action on the pin is based on the value of control bits CCP1M3:CCP1M0 (CCP1CON<3:0>). At the same time, interrupt flag bit CCP1IF is set.

FIGURE 11-1: COMPARE MODE OPERATION BLOCK DIAGRAM

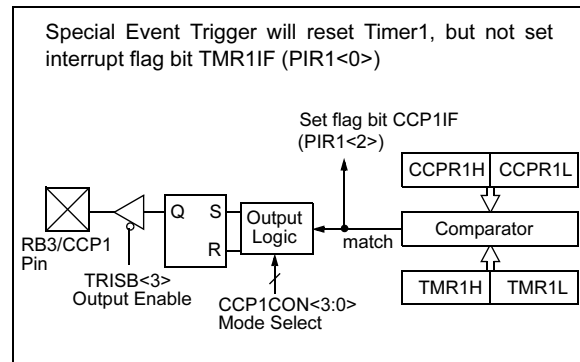

11.2.1 CCP PIN CONFIGURATION

The user must configure the RB3/CCP1 pin as an output by clearing the TRISB<3> bit.

Note: Clearing the CCP1CON register will force the RB3/CCP1 compare output latch to the default low level. This is not the data latch.

11.2.2 TIMER1 MODE SELECTION

Timer1 must be running in Timer mode or Synchronized Counter mode if the CCP module is using the compare feature. In Asynchronous Counter mode, the compare operation may not work.

11.2.3 SOFTWARE INTERRUPT MODE

When generate software interrupt is chosen, the CCP1 pin is not affected. Only a CCP interrupt is generated (if enabled).

11.2.4 SPECIAL EVENT TRIGGER

In this mode, an internal hardware trigger is generated which may be used to initiate an action.

The special event trigger output of CCP1 resets the TMR1 register pair. This allows the CCPR1 register to effectively be a 16-bit programmable period register for Timer1.

TABLE 11-3: REGISTERS ASSOCIATED WITH CAPTURE, COMPARE, AND TIMER1

Address	Name	Bit 7	Bit 6	Bit 5	Bit 4	Bit 3	Bit 2	Bit 1	Bit 0	Value on POR	Value on all other RESETS
0Bh/8Bh/ 10Bh/ 18Bh	INTCON	GIE	PEIE	T0IE	INTE	RBIE	T0IF	INTF	RBIF	0000 000x	0000 000u
0Ch	PIR1	EEIF	CMIF	RCIF	TXIF	—	CCP1IF	TMR2IF	TMR1IF	0000 -000	0000 -000
8Ch	PIE1	EEIE	CMIE	RCIE	TXIE	—	CCP1IE	TMR2IE	TMR1IE	0000 -000	0000 -000
87h	TRISB	PORTB Data Direction Register								1111 1111	1111 1111
0Eh	TMR1L	Holding register for the Least Significant Byte of the 16-bit TMR1 register								xxxx xxxx	uuuu uuuu
0Fh	TMR1H	Holding register for the Most Significant Byte of the 16-bit TMR1 register								xxxx xxxx	uuuu uuuu
10h	T1CON	—	—	T1CKPS1	T1CKPS0	T1OSCEN	T1SYNC	TMR1CS	TMR1ON	--00 0000	--uu uuuu
15h	CCPR1L	Capture/Compare/PWM register1 (LSB)								xxxx xxxx	uuuu uuuu
16h	CCPR1H	Capture/Compare/PWM register1 (MSB)								xxxx xxxx	uuuu uuuu
17h	CCP1CON	—	—	CCP1X	CCP1Y	CCP1M3	CCP1M2	CCP1M1	CCP1M0	--00 0000	--00 0000

Legend: x = unknown, u = unchanged, - = unimplemented read as '0'. Shaded cells are not used by Capture and Timer1.

PIC16F62X

11.3 PWM Mode

In Pulse Width Modulation (PWM) mode, the CCP1 pin produces up to a 10-bit resolution PWM output. Since the CCP1 pin is multiplexed with the PORTB data latch, the TRISB<3> bit must be cleared to make the CCP1 pin an output.

Note: Clearing the CCP1CON register will force the CCP1 PWM output latch to the default low level. This is not the PORTB I/O data latch.

Figure 11-2 shows a simplified block diagram of the CCP module in PWM mode.

For a step-by-step procedure on how to set up the CCP module for PWM operation, see Section 11.3.3.

FIGURE 11-2: SIMPLIFIED PWM BLOCK DIAGRAM

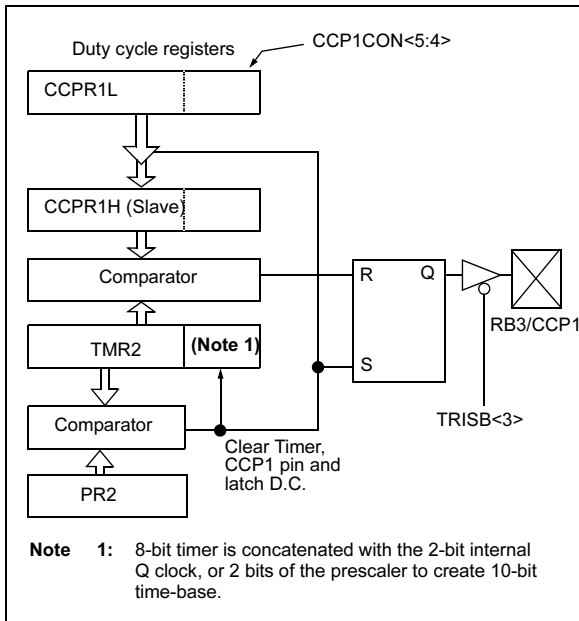

A PWM output (Figure 11-3) has a time-base (period) and a time that the output stays high (duty cycle). The frequency of the PWM is the inverse of the period (1/period).

FIGURE 11-3: PWM OUTPUT

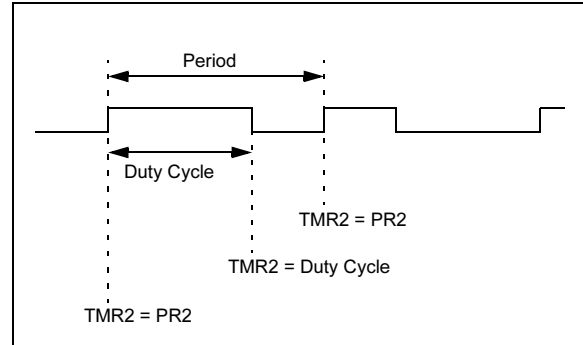

11.3.1 PWM PERIOD

The PWM period is specified by writing to the PR2 register. The PWM period can be calculated using the following formula:

$$\text{PWM period} = [(PR2) + 1] \cdot 4 \cdot T_{osc} \cdot (\text{TMR2 prescale value})$$

PWM frequency is defined as $1 / [\text{PWM period}]$.

When TMR2 is equal to PR2, the following three events occur on the next increment cycle:

- TMR2 is cleared
- The CCP1 pin is set (exception: if PWM duty cycle = 0%, the CCP1 pin will not be set)
- The PWM duty cycle is latched from CCPR1L into CCPR1H

Note: The Timer2 postscaler (see Section 8.0) is not used in the determination of the PWM frequency. The postscaler could be used to have an interrupt occur at a different frequency than the PWM output.

11.3.2 PWM DUTY CYCLE

The PWM duty cycle is specified by writing to the CCPR1L register and to the CCP1CON<5:4> bits. Up to 10-bit resolution is available: the CCPR1L contains the eight MSBs and the CCP1CON<5:4> contains the two LSbs. This 10-bit value is represented by CCPR1L:CCP1CON<5:4>. The following equation is used to calculate the PWM duty cycle in time:

EQUATION 11-1: PWM DUTY CYCLE

$$\text{PWM duty cycle} = (\text{CCPR1L:CCP1CON}\langle 5:4 \rangle) \cdot \text{Tosc} \cdot (\text{TMR2 prescale value})$$

CCPR1L and CCP1CON<5:4> can be written to at any time, but the duty cycle value is not latched into CCPR1H until after a match between PR2 and TMR2 occurs (i.e., the period is complete). In PWM mode, CCPR1H is a read-only register.

The CCPR1H register and a 2-bit internal latch are used to double buffer the PWM duty cycle. This double buffering is essential for glitchless PWM operation.

When the CCPR1H and 2-bit latch match TMR2 concatenated with an internal 2-bit Q clock or 2 bits of the TMR2 prescaler, the CCP1 pin is cleared.

Maximum PWM resolution (bits) for a given PWM frequency:

EQUATION 11-2: MAXIMUM PWM RESOLUTION

$$\text{PWM Resolution} = \frac{\log \left(\frac{F_{\text{osc}}}{F_{\text{pwm}} \times \text{TMR2 Prescaler}} \right)}{\log(2)} \text{ bits}$$

Note: If the PWM duty cycle value is longer than the PWM period, the CCP1 pin will not be cleared.

For an example on the PWM period and duty cycle calculation, see the PICmicro™ Mid-Range Reference Manual (DS33023).

11.3.3 SET-UP FOR PWM OPERATION

The following steps should be taken when configuring the CCP module for PWM operation:

1. Set the PWM period by writing to the PR2 register.
2. Set the PWM duty cycle by writing to the CCPR1L register and CCP1CON<5:4> bits.
3. Make the CCP1 pin an output by clearing the TRISB<3> bit.
4. Set the TMR2 prescale value and enable Timer2 by writing to T2CON.

TABLE 11-4: EXAMPLE PWM FREQUENCIES AND RESOLUTIONS AT 20 MHz

PWM Frequency	1.22 kHz	4.88 kHz	19.53 kHz	78.12 kHz	156.3 kHz	208.3 kHz
Timer Prescaler (1, 4, 16)	16	4	1	1	1	1
PR2 Value	0xFF	0xFF	0xFF	0x3F	0x1F	0x17
Maximum Resolution (bits)	10	10	10	8	7	6.5

TABLE 11-5: REGISTERS ASSOCIATED WITH PWM AND TIMER2

Address	Name	Bit 7	Bit 6	Bit 5	Bit 4	Bit 3	Bit 2	Bit 1	Bit 0	Value on POR	Value on all other RESETS
0Bh/8Bh/10Bh/18Bh	INTCON	GIE	PEIE	T0IE	INTE	RBIE	T0IF	INTF	RBF	0000 000x	0000 000u
0Ch	PIR1	EEIF	CMIF	RCIF	TXIF	—	CCP1IF	TMR2IF	TMR1IF	0000 -000	0000 -000
8Ch	PIE1	EEIE	CMIE	RCIE	TXIE	—	CCP1IE	TMR2IE	TMR1IE	0000 -000	0000 -000
87h	TRISB	PORTB Data Direction Register								1111 1111	1111 1111
11h	TMR2	Timer2 module's register								0000 0000	0000 0000
92h	PR2	Timer2 module's period register								1111 1111	1111 1111
12h	T2CON	—	TOUTPS3	TOUTPS2	TOUTPS1	TOUTPS0	TMR2ON	T2CKPS1	T2CKPS0	-000 0000	uuuu
15h	CCPR1L	Capture/Compare/PWM register1 (LSB)								xxxx xxxx	uuuu uuuu
16h	CCPR1H	Capture/Compare/PWM register1 (MSB)								xxxx xxxx	uuuu uuuu
17h	CCP1CON	—	—	CCP1X	CCP1Y	CCP1M3	CCP1M2	CCP1M1	CCP1M0	--00 0000	--00 0000

Legend: x = unknown, u = unchanged, - = unimplemented read as '0'. Shaded cells are not used by PWM and Timer2.

PIC16F62X

NOTES:

12.0 UNIVERSAL SYNCHRONOUS/ ASYNCHRONOUS RECEIVER/ TRANSMITTER (USART) MODULE

The Universal Synchronous Asynchronous Receiver Transmitter (USART) module is one of the two serial I/O modules. (USART is also known as a Serial Communications Interface or SCI). The USART can be configured as a full duplex asynchronous system that can communicate with peripheral devices such as CRT terminals and personal computers, or it can be configured as a half duplex synchronous system that can communicate with peripheral devices such as A/D or D/A integrated circuits, Serial EEPROMs etc.

The USART can be configured in the following modes:

- Asynchronous (full duplex)
- Synchronous - Master (half duplex)
- Synchronous - Slave (half duplex)

Bit SPEN (RCSTA<7>), and bits TRISB<2:1>, have to be set in order to configure pins RB2/TX/CK and RB1/RX/DT as the Universal Synchronous Asynchronous Receiver Transmitter.

REGISTER 12-1: TXSTA: TRANSMIT STATUS AND CONTROL REGISTER (ADDRESS: 98h)

R/W-0	R/W-0	R/W-0	R/W-0	U-0	R/W-0	R-1	R/W-0
CSRC	TX9	TXEN	SYNC	—	BRGH	TRMT	TX9D
						bit 7	bit 0

bit 7	CSRC: Clock Source Select bit <u>Asynchronous mode</u> Don't care <u>Synchronous mode</u> 1 = Master mode (Clock generated internally from BRG) 0 = Slave mode (Clock from external source)
bit 6	TX9: 9-bit Transmit Enable bit 1 = Selects 9-bit transmission 0 = Selects 8-bit transmission
bit 5	TXEN: Transmit Enable bit ⁽¹⁾ 1 = Transmit enabled 0 = Transmit disabled
bit 4	SYNC: USART Mode Select bit 1 = Synchronous mode 0 = Asynchronous mode
bit 3	Unimplemented: Read as '0'
bit 2	BRGH: High Baud Rate Select bit <u>Asynchronous mode</u> 1 = High speed 0 = Low speed <u>Synchronous mode</u> Unused in this mode
bit 1	TRMT: Transmit Shift Register STATUS bit 1 = TSR empty 0 = TSR full
bit 0	TX9D: 9th bit of transmit data. Can be PARITY bit.

Note 1: SREN/CREN overrides TXEN in SYNC mode.

Legend:

R = Readable bit	W = Writable bit	U = Unimplemented bit, read as '0'
-n = Value at POR	'1' = Bit is set	'0' = Bit is cleared x = Bit is unknown

PIC16F62X

REGISTER 12-2: RCSTA: RECEIVE STATUS AND CONTROL REGISTER (ADDRESS: 18h)

R/W-0	R/W-0	R/W-0	R/W-0	R/W-0	R-0	R-0	R-x
SPEN	RX9	SREN	CREN	ADEN	FERR	OERR	RX9D
bit 7							bit 0

- bit 7 **SPEN:** Serial Port Enable bit
(Configures RB1/RX/DT and RB2/TX/CK pins as serial port pins when bits TRISB<2:17> are set)
1 = Serial port enabled
0 = Serial port disabled
- bit 6 **RX9:** 9-bit Receive Enable bit
1 = Selects 9-bit reception
0 = Selects 8-bit reception
- bit 5 **SREN:** Single Receive Enable bit
Asynchronous mode:
Don't care
Synchronous mode - master:
1 = Enables single receive
0 = Disables single receive
This bit is cleared after reception is complete.
Synchronous mode - slave:
Unused in this mode
- bit 4 **CREN:** Continuous Receive Enable bit
Asynchronous mode:
1 = Enables continuous receive
0 = Disables continuous receive
Synchronous mode:
1 = Enables continuous receive until enable bit CREN is cleared (CREN overrides SREN)
0 = Disables continuous receive
- bit 3 **ADEN:** Address Detect Enable bit
Asynchronous mode 9-bit (RX9 = 1):
1 = Enables address detection, enable interrupt and load of the receive buffer when RSR<8> is set
0 = Disables address detection, all bytes are received, and ninth bit can be used as PARITY bit
Asynchronous mode 8-bit (RX9=0):
Unused in this mode
Synchronous mode
Unused in this mode
- bit 2 **FERR:** Framing Error bit
1 = Framing error (Can be updated by reading RCREG register and receive next valid byte)
0 = No framing error
- bit 1 **OERR:** Overrun Error bit
1 = Overrun error (Can be cleared by clearing bit CREN)
0 = No overrun error
- bit 0 **RX9D:** 9th bit of received data (Can be PARITY bit)

Legend:

R = Readable bit	W = Writable bit	U = Unimplemented bit, read as '0'
-n = Value at POR	'1' = Bit is set	'0' = Bit is cleared x = Bit is unknown

12.1 USART Baud Rate Generator (BRG)

The BRG supports both the Asynchronous and Synchronous modes of the USART. It is a dedicated 8-bit baud rate generator. The SPBRG register controls the period of a free running 8-bit timer. In Asynchronous mode bit BRGH (TXSTA<2>) also controls the baud rate. In Synchronous mode bit BRGH is ignored. Table 12-1 shows the formula for computation of the baud rate for different USART modes which only apply in Master mode (internal clock).

Given the desired baud rate and Fosc, the nearest integer value for the SPBRG register can be calculated using the formula in Table 12-1. From this, the error in baud rate can be determined.

Example 12-1 shows the calculation of the baud rate error for the following conditions:

Fosc = 16 MHz

Desired Baud Rate = 9600

BRGH = 0

SYNC = 0

EXAMPLE 12-1: CALCULATING BAUD RATE ERROR

$$\text{Desired Baud rate} = F_{\text{osc}} / (64(X + 1))$$

$$9600 = 16000000 / (64(+ 1))X$$

$$X = 125.042^{\circ}$$

$$\text{Calculated Baud Rate} = 16000000 / (64(25 + 1))$$

$$= 9615$$

$$\text{Error} = \frac{(\text{Calculated Baud Rate} - \text{Desired Baud Rate})}{\text{Desired Baud Rate}}$$

$$= (9615 - 9600) / 9600$$

$$= 0.16\%$$

It may be advantageous to use the high baud rate (BRGH = 1) even for slower baud clocks. This is because the $F_{\text{osc}} / (16(X + 1))$ equation can reduce the baud rate error in some cases.

Writing a new value to the SPBRG register, causes the BRG timer to be RESET (or cleared), this ensures the BRG does not wait for a timer overflow before outputting the new baud rate.

TABLE 12-1: BAUD RATE FORMULA

SYNC	BRGH = 0 (Low Speed)	BRGH = 1 (High Speed)
0	(Asynchronous) Baud Rate = $F_{\text{osc}} / (64(X+1))$	Baud Rate = $F_{\text{osc}} / (16(X+1))$
1	(Synchronous) Baud Rate = $F_{\text{osc}} / (4(X+1))$	NA

Legend: X = value in SPBRG (0 to 255)

TABLE 12-2: REGISTERS ASSOCIATED WITH BAUD RATE GENERATOR

Address	Name	Bit 7	Bit 6	Bit 5	Bit 4	Bit 3	Bit 2	Bit 1	Bit 0	Value on POR	Value on all other RESETS	
98h	TXSTA	CSRC	TX9	TXEN	SYNC	—	BRGH	TRMT	TX9D	0000 -010	0000 -010	
18h	RCSTA	SPEN	RX9	SREN	CREN	ADEN	FERR	OERR	RX9D	0000 -00x	0000 -00x	
99h	SPBRG	Baud Rate Generator Register									0000 0000	0000 0000

Legend: x = unknown, - = unimplemented read as '0'.
Shaded cells are not used by the BRG.

PIC16F62X

TABLE 12-3: BAUD RATES FOR SYNCHRONOUS MODE

BAUD RATE (K)	Fosc = 20 MHz			16 MHz			10 MHz		
	KBAUD	ERROR	SPBRG value (decimal)	KBAUD	ERROR	SPBRG value (decimal)	KBAUD	ERROR	SPBRG value (decimal)
0.3	NA	—	—	NA	—	—	NA	—	—
1.2	NA	—	—	NA	—	—	NA	—	—
2.4	NA	—	—	NA	—	—	NA	—	—
9.6	NA	—	—	NA	—	—	9.766	+1.73%	255
19.2	19.53	+1.73%	255	19.23	+0.16%	207	19.23	+0.16%	129
76.8	76.92	+0.16%	64	76.92	+0.16%	51	75.76	-1.36%	32
96	96.15	+0.16%	51	95.24	-0.79%	41	96.15	+0.16%	25
300	294.1	-1.96	16	307.69	+2.56%	12	312.5	+4.17%	7
500	500	0	9	500	0	7	500	0	4
HIGH	5000	—	0	4000	—	0	2500	—	0
LOW	19.53	—	255	15.625	—	255	9.766	—	255

BAUD RATE (K)	Fosc = 7.15909 MHz			5.0688 MHz			4 MHz		
	KBAUD	ERROR	SPBRG value (decimal)	KBAUD	ERROR	SPBRG value (decimal)	KBAUD	ERROR	SPBRG value (decimal)
0.3	NA	—	—	NA	—	—	NA	—	—
1.2	NA	—	—	NA	—	—	NA	—	—
2.4	NA	—	—	NA	—	—	NA	—	—
9.6	9.622	+0.23%	185	9.6	0	131	9.615	+0.16%	103
19.2	19.24	+0.23%	92	19.2	0	65	19.231	+0.16%	51
76.8	77.82	+1.32	22	79.2	+3.13%	15	75.923	+0.16%	12
96	94.20	-1.88	18	97.48	+1.54%	12	1000	+4.17%	9
300	298.3	-0.57	5	316.8	5.60%	3	NA	—	—
500	NA	—	—	NA	—	—	NA	—	—
HIGH	1789.8	—	0	1267	—	0	100	—	0
LOW	6.991	—	255	4.950	—	255	3.906	—	255

BAUD RATE (K)	Fosc = 3.579545 MHz			1 MHz			32.768 MHz		
	KBAUD	ERROR	SPBRG value (decimal)	KBAUD	ERROR	SPBRG value (decimal)	KBAUD	ERROR	SPBRG value (decimal)
0.3	NA	—	—	NA	—	—	0.303	+1.14%	26
1.2	NA	—	—	1.202	+0.16%	207	1.170	-2.48%	6
2.4	NA	—	—	2.404	+0.16%	103	NA	—	—
9.6	9.622	+0.23%	92	9.615	+0.16%	25	NA	—	—
19.2	19.04	-0.83%	46	19.24	+0.16%	12	NA	—	—
76.8	74.57	-2.90%	11	83.34	+8.51%	2	NA	—	—
96	99.43	+3.57%	8	NA	—	—	NA	—	—
300	298.3	0.57%	2	NA	—	—	NA	—	—
500	NA	—	—	NA	—	—	—	—	—
HIGH	894.9	—	0	250	—	0	8.192	—	0
LOW	3.496	—	255	0.9766	—	255	0.032	—	255

TABLE 12-4: BAUD RATES FOR ASYNCHRONOUS MODE (BRGH = 0)

BAUD RATE (K)	Fosc = 20 MHz			16 MHz			10 MHz		
	KBAUD	ERROR	SPBRG value (decimal)	KBAUD	ERROR	SPBRG value (decimal)	KBAUD	ERROR	SPBRG value (decimal)
0.3	NA	—	—	NA	—	—	NA	—	—
1.2	1.221	+1.73%	255	1.202	+0.16%	207	1.202	+0.16%	129
2.4	2.404	+0.16%	129	2.404	+0.16%	103	2.404	+0.16%	64
9.6	9.469	-1.36%	32	9.615	+0.16%	25	9.766	+1.73%	15
19.2	19.53	+1.73%	15	19.23	+0.16%	12	19.53	+1.73V	7
76.8	78.13	+1.73%	3	83.33	+8.51%	2	78.13	+1.73%	1
96	104.2	+8.51%	2	NA	—	—	NA	—	—
300	312.5	+4.17%	0	NA	—	—	NA	—	—
500	NA	—	—	NA	—	—	NA	—	—
HIGH	312.5	—	0	250	—	0	156.3	—	0
LOW	1.221	—	255	0.977	—	255	0.6104	—	255

BAUD RATE (K)	Fosc = 7.15909 MHz			5.0688 MHz			4 MHz		
	KBAUD	ERROR	SPBRG value (decimal)	KBAUD	ERROR	SPBRG value (decimal)	KBAUD	ERROR	SPBRG value (decimal)
0.3	NA	—	—	0.31	+3.13%	255	0.3005	-0.17%	207
1.2	1.203	+0.23%	92	1.2	0	65	1.202	+1.67%	51
2.4	2.380	-0.83%	46	2.4	0	32	2.404	+1.67%	25
9.6	9.322	-2.90%	11	9.9	+3.13%	7	NA	—	—
19.2	18.64	-2.90%	5	19.8	+3.13%	3	NA	—	—
76.8	NA	—	—	79.2	+3.13%	0	NA	—	—
96	NA	—	—	NA	—	—	NA	—	—
300	NA	—	—	NA	—	—	NA	—	—
500	NA	—	—	NA	—	—	NA	—	—
HIGH	111.9	—	0	79.2	—	0	62.500	—	0
LOW	0.437	—	255	0.3094	—	255	3.906	—	255

BAUD RATE (K)	Fosc = 3.579545 MHz			1 MHz			32.768 MHz		
	KBAUD	ERROR	SPBRG value (decimal)	KBAUD	ERROR	SPBRG value (decimal)	KBAUD	ERROR	SPBRG value (decimal)
0.3	0.301	+0.23%	185	0.300	+0.16%	51	0.256	-14.67%	1
1.2	1.190	-0.83%	46	1.202	+0.16%	12	NA	—	—
2.4	2.432	+1.32%	22	2.232	-6.99%	6	NA	—	—
9.6	9.322	-2.90%	5	NA	—	—	NA	—	—
19.2	18.64	-2.90%	2	NA	—	—	NA	—	—
76.8	NA	—	—	NA	—	—	NA	—	—
96	NA	—	—	NA	—	—	NA	—	—
300	NA	—	—	NA	—	—	NA	—	—
500	NA	—	—	NA	—	—	NA	—	—
HIGH	55.93	—	0	15.63	—	0	0.512	—	0
LOW	0.2185	—	255	0.0610	—	255	0.0020	—	255

PIC16F62X

TABLE 12-5: BAUD RATES FOR ASYNCHRONOUS MODE (BRGH = 1)

BAUD RATE (K)	Fosc = 20 MHz			16 MHz			10 MHz		
	KBAUD	ERROR	SPBRG value (decimal)	KBAUD	ERROR	SPBRG value (decimal)	KBAUD	ERROR	SPBRG value (decimal)
9600	9.615	+0.16%	129	9.615	+0.16%	103	9.615	+0.16%	64
19200	19.230	+0.16%	64	19.230	+0.16%	51	18.939	-1.36%	32
38400	37.878	-1.36%	32	38.461	+0.16%	25	39.062	+1.7%	15
57600	56.818	-1.36%	21	58.823	+2.12%	16	56.818	-1.36%	10
115200	113.636	-1.36%	10	111.111	-3.55%	8	125	+8.51%	4
250000	250	0	4	250	0	3	NA	—	—
625000	625	0	1	NA	—	—	625	0	0
1250000	1250	0	0	NA	—	—	NA	—	—

BAUD RATE (K)	Fosc = 7.16 MHz			5.068 MHz			4 MHz		
	KBAUD	ERROR	SPBRG value (decimal)	KBAUD	ERROR	SPBRG value (decimal)	KBAUD	ERROR	SPBRG value (decimal)
9600	9.520	-0.83%	46	9598.485	0.016%	32	9615.385	0.160%	25
19200	19.454	+1.32%	22	18632.35	-2.956%	16	19230.77	0.160%	12
38400	37.286	-2.90%	11	39593.75	3.109%	7	35714.29	-6.994%	6
57600	55.930	-2.90%	7	52791.67	-8.348%	5	62500	8.507%	3
115200	111.860	-2.90%	3	105583.3	-8.348%	2	125000	8.507%	1
250000	NA	—	—	316750	26.700%	0	250000	0.000%	0
625000	NA	—	—	NA	—	—	NA	—	—
1250000	NA	—	—	NA	—	—	NA	—	—

BAUD RATE (K)	Fosc = 3.579 MHz			1 MHz			32.768 MHz		
	KBAUD	ERROR	SPBRG value (decimal)	KBAUD	ERROR	SPBRG value (decimal)	KBAUD	ERROR	SPBRG value (decimal)
9600	9725.543	1.308%	22	8.928	-6.994%	6	NA	NA	NA
19200	18640.63	-2.913%	11	20833.3	8.507%	2	NA	NA	NA
38400	37281.25	-2.913%	5	31250	-18.620%	1	NA	NA	NA
57600	55921.88	-2.913%	3	62500	+8.507	0	NA	NA	NA
115200	111243.8	-2.913%	1	NA	—	—	NA	NA	NA
250000	223687.5	-10.525%	0	NA	—	—	NA	NA	NA
625000	NA	—	—	NA	—	—	NA	NA	NA
1250000	NA	—	—	NA	—	—	NA	NA	NA

The data on the RB1/RX/DT pin is sampled three times by a majority detect circuit to determine if a high or a low level is present at the RX pin. If bit BRGH (TXSTA<2>) is clear (i.e., at the low baud rates), the sampling is done on the seventh, eighth and ninth falling edges of a x16 clock (Figure 12-3). If bit BRGH is set (i.e., at the high baud rates), the sampling is done on the 3 clock edges preceding the second rising edge after the first falling edge of a x4 clock (Figure 12-4 and Figure 12-5).

FIGURE 12-1: RX PIN SAMPLING SCHEME, BRGH = 0

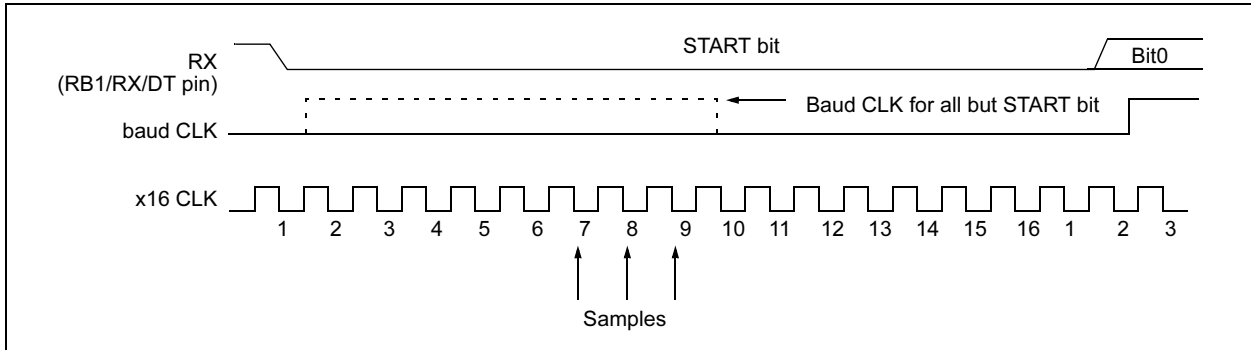

FIGURE 12-2: RX PIN SAMPLING SCHEME, BRGH = 1

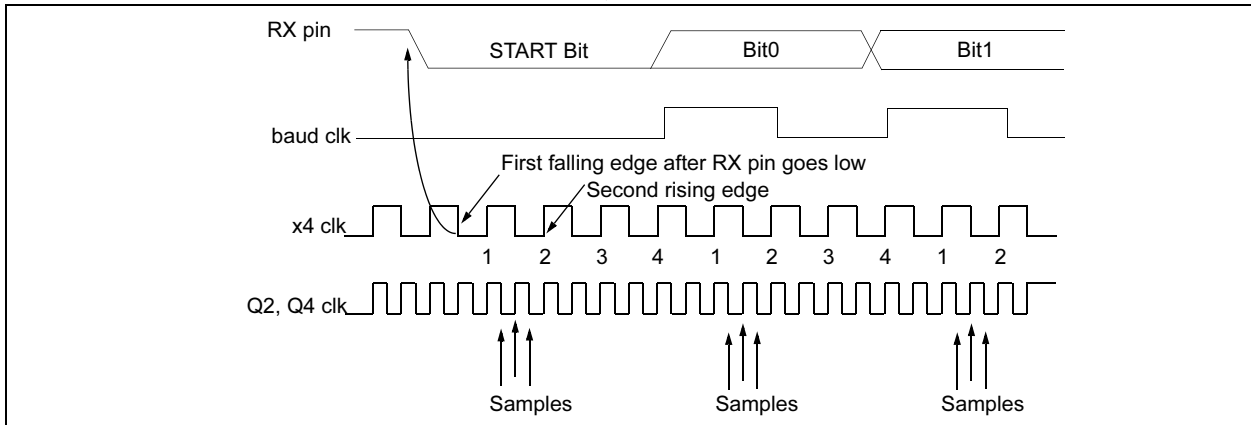
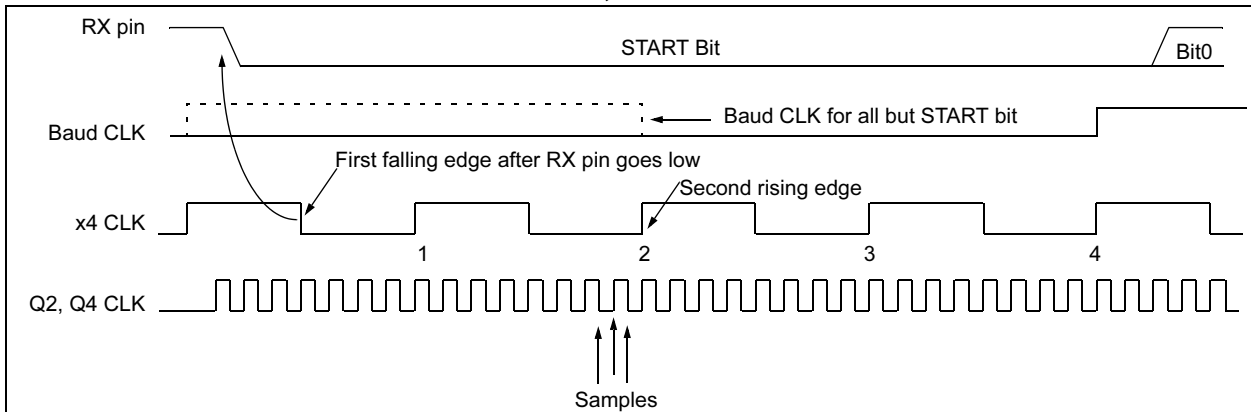
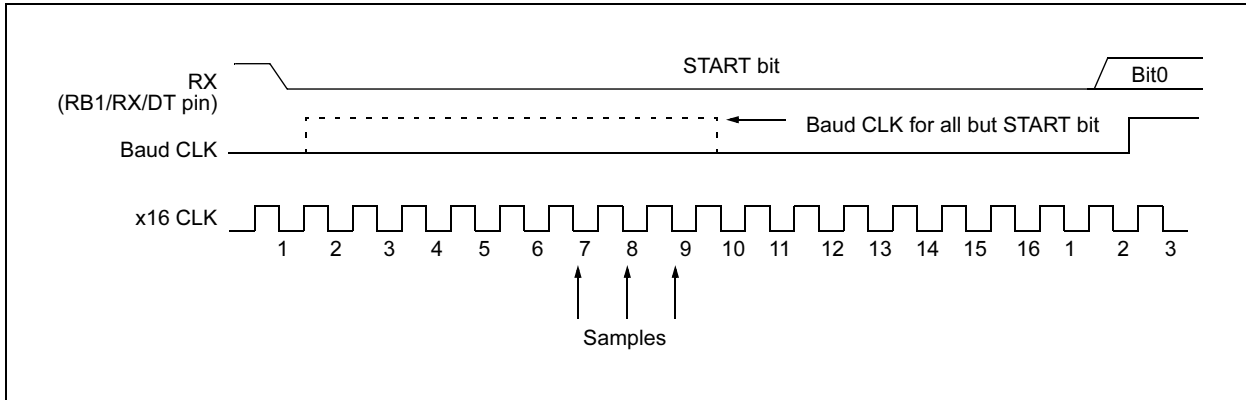

FIGURE 12-3: RX PIN SAMPLING SCHEME, BRGH = 1



PIC16F62X

FIGURE 12-4: RX PIN SAMPLING SCHEME, BRGH = 0 OR BRGH = 1



12.2 USART Asynchronous Mode

In this mode, the USART uses standard non-return to zero (NRZ) format (one START bit, eight or nine data bits and one STOP bit). The most common data format is 8 bits. A dedicated 8-bit baud rate generator is used to derive baud rate frequencies from the oscillator. The USART transmits and receives the LSb first. The USART's transmitter and receiver are functionally independent but use the same data format and baud rate. The baud rate generator produces a clock either x16 or x64 of the bit shift rate, depending on bit BRGH (TXSTA<2>). Parity is not supported by the hardware, but can be implemented in software (and stored as the ninth data bit). Asynchronous mode is stopped during SLEEP.

Asynchronous mode is selected by clearing bit SYNC (TXSTA<4>).

The USART Asynchronous module consists of the following important elements:

- Baud Rate Generator
- Sampling Circuit
- Asynchronous Transmitter
- Asynchronous Receiver

12.2.1 USART ASYNCHRONOUS TRANSMITTER

The USART transmitter block diagram is shown in Figure 12-5. The heart of the transmitter is the transmit (serial) shift register (TSR). The shift register obtains its data from the read/write transmit buffer, TXREG. The TXREG register is loaded with data in software. The TSR register is not loaded until the STOP bit has been transmitted from the previous load. As soon as the STOP bit is transmitted, the TSR is loaded with new data from the TXREG register (if available). Once the TXREG register transfers the data to the TSR register (occurs in one T_{CY}), the TXREG register is empty and flag bit TXIF (PIR1<4>) is set. This interrupt can be enabled/disabled by setting/clearing enable bit TXIE (PIE1<4>). Flag bit TXIF will be set regardless of the state of enable bit TXIE and cannot be cleared in

software. It will RESET only when new data is loaded into the TXREG register. While flag bit TXIF indicated the status of the TXREG register, another bit TRMT (TXSTA<1>) shows the status of the TSR register. STATUS bit TRMT is a read only bit which is set when the TSR register is empty. No interrupt logic is tied to this bit, so the user has to poll this bit in order to determine if the TSR register is empty.

- Note 1:** The TSR register is not mapped in data memory so it is not available to the user.
- 2:** Flag bit TXIF is set when enable bit TXEN is set.

Transmission is enabled by setting enable bit TXEN (TXSTA<5>). The actual transmission will not occur until the TXREG register has been loaded with data and the baud rate generator (BRG) has produced a shift clock (Figure 12-5). The transmission can also be started by first loading the TXREG register and then setting enable bit TXEN. Normally when transmission is first started, the TSR register is empty, so a transfer to the TXREG register will result in an immediate transfer to TSR resulting in an empty TXREG. A back-to-back transfer is thus possible (Figure 12-7). Clearing enable bit TXEN during a transmission will cause the transmission to be aborted and will RESET the transmitter. As a result the RB2/TX/CK pin will revert to hi-impedance.

In order to select 9-bit transmission, transmit bit TX9 (TXSTA<6>) should be set and the ninth bit should be written to TX9D (TXSTA<0>). The ninth bit must be written before writing the 8-bit data to the TXREG register. This is because a data write to the TXREG register can result in an immediate transfer of the data to the TSR register (if the TSR is empty). In such a case, an incorrect ninth data bit may be loaded in the TSR register.

FIGURE 12-5: USART TRANSMIT BLOCK DIAGRAM

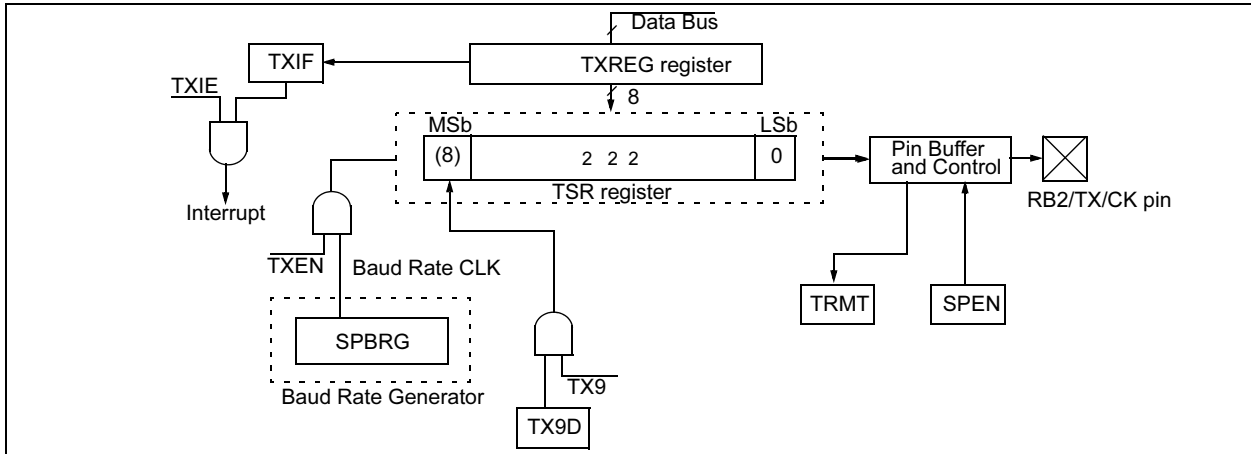

Steps to follow when setting up an Asynchronous Transmission:

1. Initialize the SPBRG register for the appropriate baud rate. If a high speed baud rate is desired, set bit BRGH. (Section 12.1)
2. Enable the asynchronous serial port by clearing bit SYNC and setting bit SPEN.
3. If interrupts are desired, then set enable bit TXIE.
4. If 9-bit transmission is desired, then set transmit bit TX9.
5. Enable the transmission by setting bit TXEN, which will also set bit TXIF.
6. If 9-bit transmission is selected, the ninth bit should be loaded in bit TX9D.
7. Load data to the TXREG register (starts transmission).

FIGURE 12-6: ASYNCHRONOUS TRANSMISSION

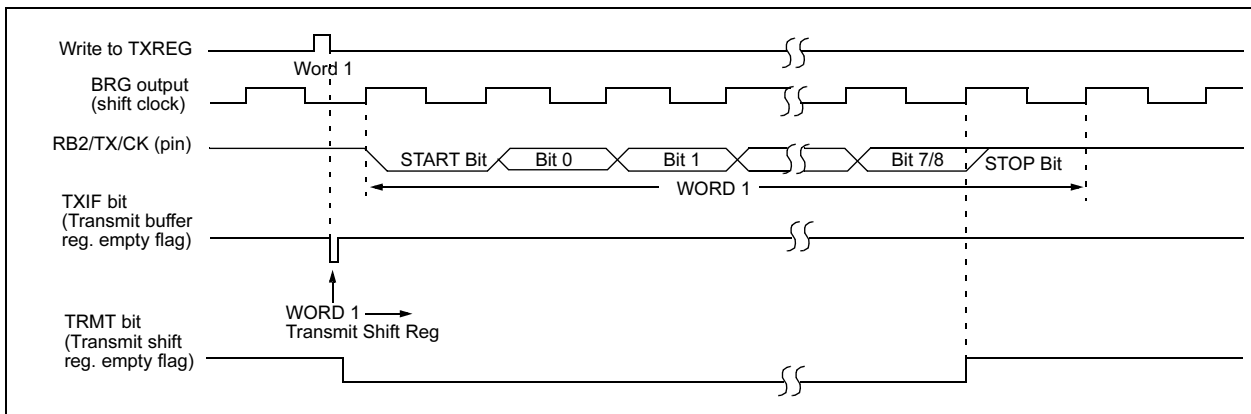

PIC16F62X

FIGURE 12-7: ASYNCHRONOUS TRANSMISSION (BACK TO BACK)

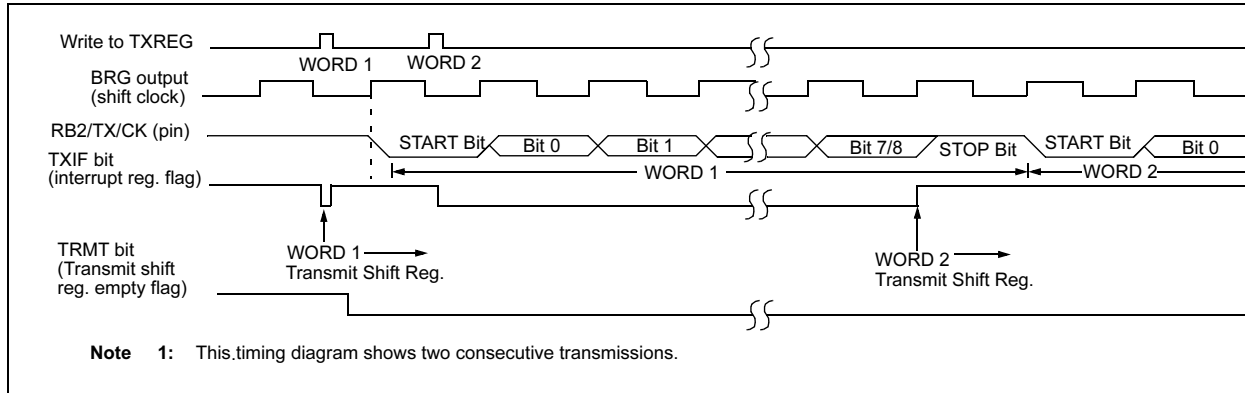

TABLE 12-6: REGISTERS ASSOCIATED WITH ASYNCHRONOUS TRANSMISSION

Address	Name	Bit 7	Bit 6	Bit 5	Bit 4	Bit 3	Bit 2	Bit 1	Bit 0	Value on POR	Value on all other RESETS
0Ch	PIR1	EEIF	CMIF	RCIF	TXIF	—	CCP1IF	TMR2IF	TMR1IF	0000 -000	0000 -000
18h	RCSTA	SPEN	RX9	SREN	CREN	ADEN	FERR	OERR	RX9D	0000 -00x	0000 -00x
19h	TXREG	USART Transmit Register								0000 0000	0000 0000
8Ch	PIE1	EEIE	CMIE	RCIE	TXIE	—	CCP1IE	TMR2IE	TMR1IE	0000 -000	0000 -000
98h	TXSTA	CSRC	TX9	TXEN	SYNC	—	BRGH	TRMT	TX9D	0000 -010	0000 -010
99h	SPBRG	Baud Rate Generator Register								0000 0000	0000 0000

Legend: x = unknown, - = unimplemented locations read as '0'.
Shaded cells are not used for Asynchronous Transmission.

12.2.2 ADEN USART ASYNCHRONOUS RECEIVER

The receiver block diagram is shown in Figure 12-8. The data is received on the RB1/RX/DT pin and drives the data recovery block. The data recovery block is actually a high speed shifter operating at x16 times the baud rate, whereas the main receive serial shifter operates at the bit rate or at FOSC.

Once Asynchronous mode is selected, reception is enabled by setting bit CREN (RCSTA<4>).

The heart of the receiver is the Receive (serial) Shift register (RSR). After sampling the STOP bit, the received data in the RSR is transferred to the RCREG register (if it is empty). If the transfer is complete, flag bit RCIF (PIR1<5>) is set. The actual interrupt can be enabled/disabled by setting/clearing enable bit RCIE (PIE1<5>). Flag bit RCIF is a read only bit which is cleared by the hardware. It is cleared when the RCREG register has been read and is empty. The RCREG is a double buffered register (i.e., it is a two-deep FIFO).

It is possible for two bytes of data to be received and transferred to the RCREG FIFO, and a third byte begin shifting to the RSR register. On the detection of the STOP bit of the third byte, if the RCREG register is still full, then overrun error bit OERR (RCSTA<1>) will be set. The word in the RSR will be lost. The RCREG register can be read twice to retrieve the two bytes in the FIFO. Overrun bit OERR has to be cleared in software. This is done by resetting the receive logic (CREN is cleared and then set). If bit OERR is set, transfers from the RSR register to the RCREG register are inhibited, so it is essential to clear error bit OERR if it is set. Framing error bit FERR (RCSTA<2>) is set if a STOP bit is detected as clear. Bit FERR and the 9th receive bit are buffered the same way as the receive data. Reading the RCREG will load bits RX9D and FERR with new values, therefore it is essential for the user to read the RCSTA register before reading the RCREG register in order not to lose the old FERR and RX9D information.

FIGURE 12-8: USART RECEIVE BLOCK DIAGRAM

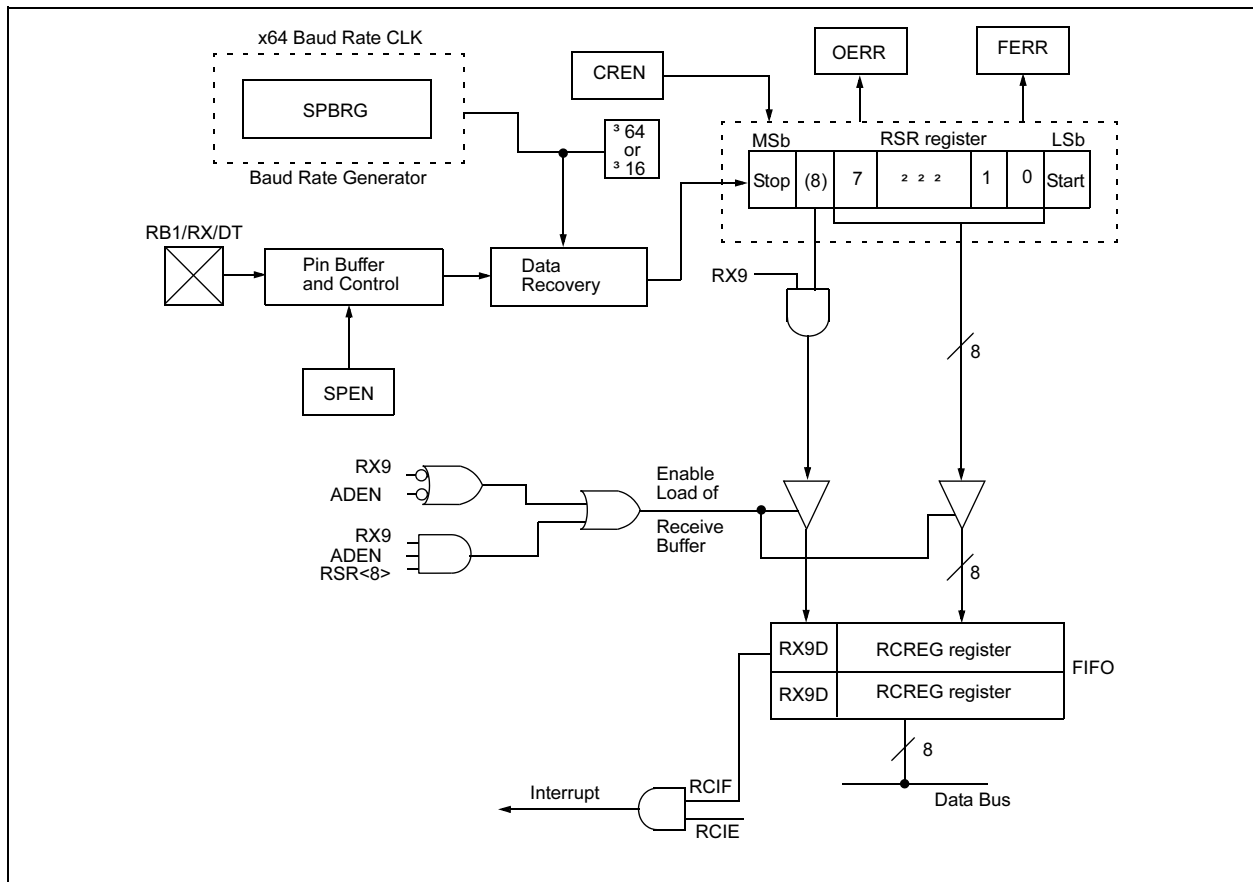

PIC16F62X

FIGURE 12-9: ASYNCHRONOUS RECEPTION WITH ADDRESS DETECT

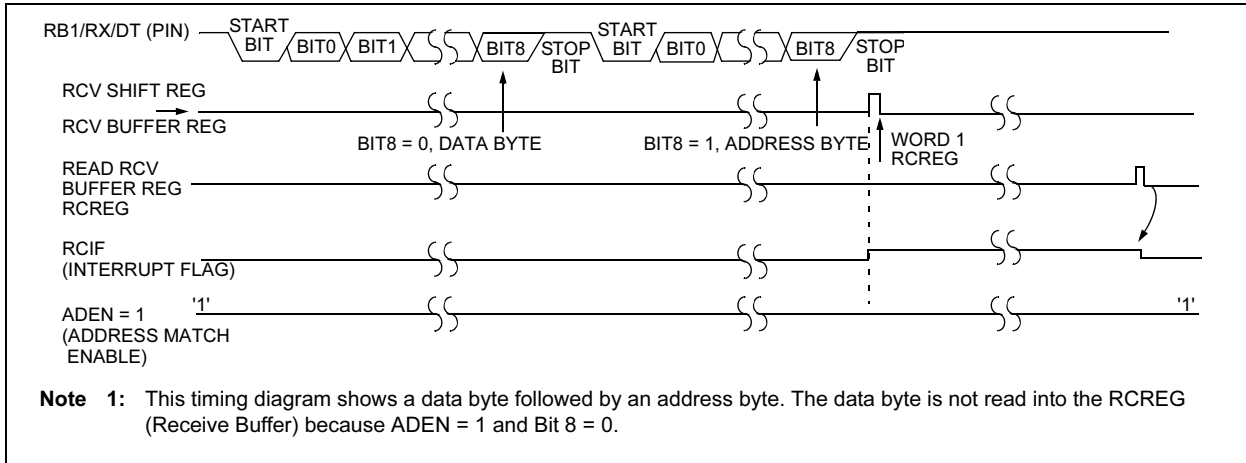

FIGURE 12-10: ASYNCHRONOUS RECEPTION WITH ADDRESS BYTE FIRST

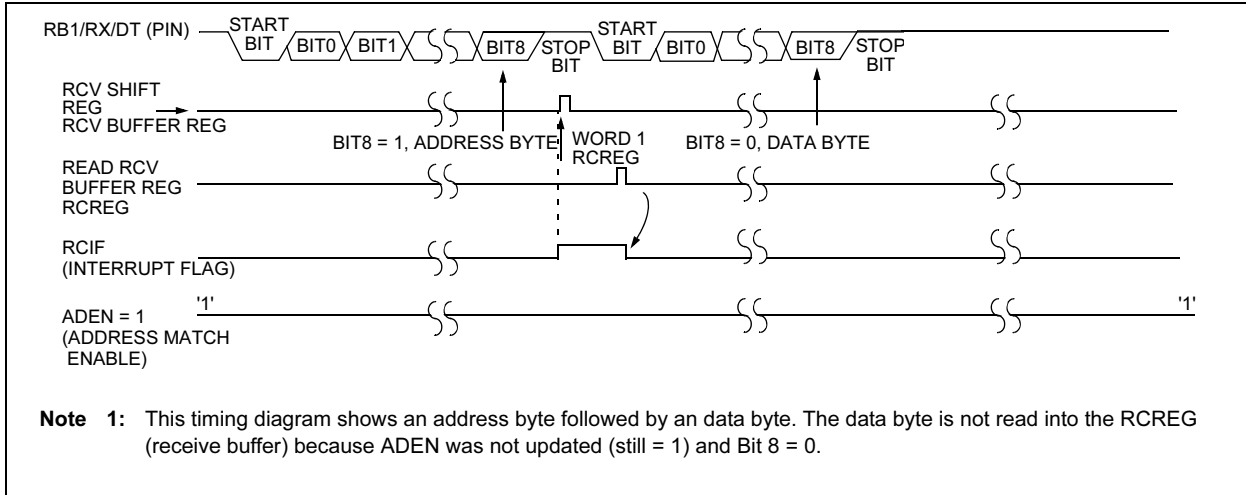
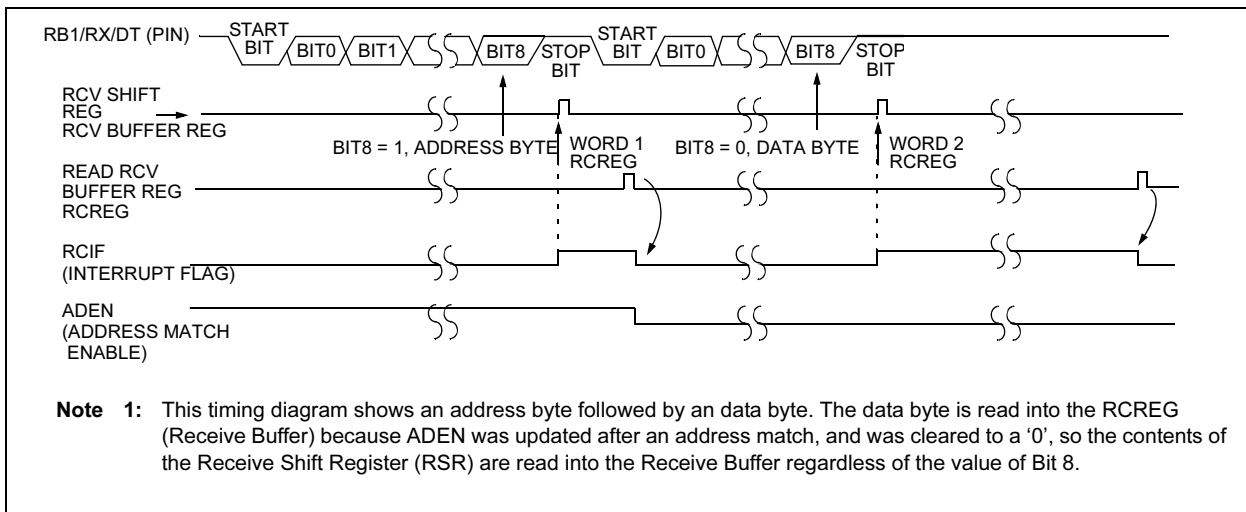

FIGURE 12-11: ASYNCHRONOUS RECEPTION WITH ADDRESS BYTE FIRST FOLLOWED BY VALID DATA BYTE



Steps to follow when setting up an Asynchronous Reception:

1. Initialize the SPBRG register for the appropriate baud rate. If a high speed baud rate is desired, set bit BRGH. (Section 12.1).
2. Enable the asynchronous serial port by clearing bit SYNC, and setting bit SPEN.
3. If interrupts are desired, then set enable bit RCIE.
4. If 9-bit reception is desired, then set bit RX9.
5. Enable the reception by setting bit CREN.
6. Flag bit RCIF will be set when reception is complete and an interrupt will be generated if enable bit RCIE was set.
7. Read the RCSTA register to get the ninth bit (if enabled) and determine if any error occurred during reception.
8. Read the 8-bit received data by reading the RCREG register.
9. If any error occurred, clear the error by clearing enable bit CREN.

TABLE 12-7: REGISTERS ASSOCIATED WITH ASYNCHRONOUS RECEPTION

Address	Name	Bit 7	Bit 6	Bit 5	Bit 4	Bit 3	Bit 2	Bit 1	Bit 0	Value on POR	Value on all other RESETS
0Ch	PIR1	EEIF	CMIF	RCIF	TXIF	—	CCP1IF	TMR2IF	TMR1IF	0000 -000	0000 -000
18h	RCSTA	SPEN	RX9	SREN	CREN	ADEN	FERR	OERR	RX9D	0000 -00x	0000 -00x
1Ah	RCREG	USART Receive Register								0000 0000	0000 0000
8Ch	PIE1	EEIE	CMIE	RCIE	TXIE	—	CCP1IE	TMR2IE	TMR1IE	0000 -000	0000 -000
98h	TXSTA	CSRC	TX9	TXEN	SYNC	—	BRGH	TRMT	TX9D	0000 -010	0000 -010
99h	SPBRG	Baud Rate Generator Register								0000 0000	0000 0000

Legend: x = unknown, - = unimplemented locations read as '0'. Shaded cells are not used for Asynchronous Reception.

PIC16F62X

12.3 USART Function

The USART function is similar to that on the PIC16C74B, which includes the BRGH = 1 fix.

12.3.1 USART 9-BIT RECEIVER WITH ADDRESS DETECT

When the RX9 bit is set in the RCSTA register, 9 bits are received and the ninth bit is placed in the RX9D bit of the RCSTA register. The USART module has a special provision for multiprocessor communication. Multiprocessor communication is enabled by setting the ADEN bit (RCSTA<3>) along with the RX9 bit. The port is now programmed so when the last bit is received, the contents of the Receive Shift Register (RSR) are transferred to the receive buffer. The ninth bit of the RSR (RSR<8>) is transferred to RX9D, and the receive interrupt is set if, and only, if RSR<8> = 1. This feature can be used in a multiprocessor system as follows:

A master processor intends to transmit a block of data to one of many slaves. It must first send out an address byte that identifies the target slave. An address byte is identified by setting the ninth bit (RSR<8>) to a '1' (instead of a '0' for a data byte). If the ADEN and RX9 bits are set in the slave's RCSTA register, enabling multiprocessor communication, all data bytes will be ignored. However, if the ninth received bit is equal to a '1', indicating that the received byte is an address, the slave will be interrupted and the contents of the RSR register will be transferred into the receive buffer. This allows the slave to be interrupted only by addresses, so that the slave can examine the received byte to see if it is being addressed. The addressed slave will then clear its ADEN bit and prepare to receive data bytes from the master.

When ADEN is enabled (= '1'), all data bytes are ignored. Following the STOP bit, the data will not be loaded into the receive buffer, and no interrupt will occur. If another byte is shifted into the RSR register, the previous data byte will be lost.

The ADEN bit will only take effect when the receiver is configured in 9-bit mode (RX9 = '1'). When ADEN is disabled (= '0'), all data bytes are received and the 9th bit can be used as the PARITY bit.

The USART Receive Block Diagram is shown in Figure 12-8.

Reception is enabled by setting bit CREN (RCSTA<4>).

12.3.1.1 Setting up 9-bit mode with Address Detect

Steps to follow when setting up an Asynchronous or Synchronous Reception with Address Detect Enabled:

1. Initialize the SPBRG register for the appropriate baud rate. If a high speed baud rate is desired, set bit BRGH.
2. Enable asynchronous or synchronous communication by setting or clearing bit SYNC and setting bit SPEN.
3. If interrupts are desired, then set enable bit RCIE.
4. Set bit RX9 to enable 9-bit reception.
5. Set ADEN to enable address detect.
6. Enable the reception by setting enable bit CREN or SREN.
7. Flag bit RCIF will be set when reception is complete, and an interrupt will be generated if enable bit RCIE was set.
8. Read the 8-bit received data by reading the RCREG register to determine if the device is being addressed.
9. If any error occurred, clear the error by clearing enable bit CREN if it was already set.
10. If the device has been addressed (RSR<8> = 1 with address match enabled), clear the ADEN and RCIF bits to allow data bytes and address bytes to be read into the receive buffer and interrupt the CPU.

TABLE 12-8: REGISTERS ASSOCIATED WITH ASYNCHRONOUS RECEPTION

Address	Name	Bit 7	Bit 6	Bit 5	Bit 4	Bit 3	Bit 2	Bit 1	Bit 0	Value on POR	Value on all other RESETS
0Ch	PIR1	EEIF	CMIF	RCIF	TXIF	—	CCP1IF	TMR2IF	TMR1IF	0000 -000	0000 -000
18h	RCSTA	SPEN	RX9	SREN	CREN	ADEN	FERR	OERR	RX9D	0000 -00x	0000 -00x
1Ah	RCREG	RX7	RX6	RX5	RX4	RX3	RX2	RX1	RX0	0000 0000	0000 0000
8Ch	PIE1	EEIE	CMIE	RCIE	TXIE	—	CCP1IE	TMR2IE	TMR1IE	0000 -000	0000 -000
98h	TXSTA	CSRC	TX9	TXEN	SYNC	—	BRGH	TRMT	TX9D	0000 -010	0000 -010
99h	SPBRG	Baud Rate Generator Register								0000 0000	0000 0000

Legend: x = unknown, - = unimplemented locations read as '0'. Shaded cells are not used for Asynchronous Reception.

12.4 USART Synchronous Master Mode

In Synchronous Master mode, the data is transmitted in a half-duplex manner (i.e., transmission and reception do not occur at the same time). When transmitting data, the reception is inhibited and vice versa. Synchronous mode is entered by setting bit SYNC (TXSTA<4>). In addition, enable bit SPEN (RCSTA<7>) is set in order to configure the RB2/TX/CK and RB1/RX/DT I/O pins to CK (clock) and DT (data) lines respectively. The Master mode indicates that the processor transmits the master clock on the CK line. The Master mode is entered by setting bit CSRC (TXSTA<7>).

12.4.1 USART SYNCHRONOUS MASTER TRANSMISSION

The USART Transmitter Block Diagram is shown in Figure 12-5. The heart of the transmitter is the Transmit (serial) Shift register (TSR). The Shift register obtains its data from the read/write transmit buffer register TXREG. The TXREG register is loaded with data in software. The TSR register is not loaded until the last bit has been transmitted from the previous load. As soon as the last bit is transmitted, the TSR is loaded with new data from the TXREG (if available). Once the TXREG register transfers the data to the TSR register (occurs in one Tcycle), the TXREG is empty and interrupt bit, TXIF (PIR1<4>) is set. The interrupt can be enabled/disabled by setting/clearing enable bit TXIE (PIE1<4>). Flag bit TXIF will be set regardless of the state of enable bit TXIE and cannot be cleared in software. It will RESET only when new data is loaded into the TXREG register. While flag bit TXIF indicates the status of the TXREG register, another bit TRMT (TXSTA<1>) shows the status of the TSR register. TRMT is a read only bit which is set when the TSR is empty. No interrupt logic is tied to this bit, so the user has to poll this bit in order to determine if the TSR register is empty. The TSR is not mapped in data memory so it is not available to the user.

Transmission is enabled by setting enable bit TXEN (TXSTA<5>). The actual transmission will not occur until the TXREG register has been loaded with data. The first data bit will be shifted out on the next available rising edge of the clock on the CK line. Data out is stable around the falling edge of the synchronous clock (Figure 12-12). The transmission can also be started by first loading the TXREG register and then setting bit TXEN (Figure 12-13). This is advantageous when slow baud rates are selected, since the BRG is kept in RESET when bits TXEN, CREN, and SREN are clear. Setting enable bit TXEN will start the BRG, creating a shift clock immediately. Normally when transmission is first started, the TSR register is empty, so a transfer to the TXREG register will result in an immediate transfer to TSR resulting in an empty TXREG. Back-to-back transfers are possible.

Clearing enable bit TXEN, during a transmission, will cause the transmission to be aborted and will RESET the transmitter. The DT and CK pins will revert to hi-impedance. If either bit CREN or bit SREN is set, during a transmission, the transmission is aborted and the DT pin reverts to a hi-impedance state (for a reception). The CK pin will remain an output if bit CSRC is set (internal clock). The transmitter logic however is not RESET although it is disconnected from the pins. In order to RESET the transmitter, the user has to clear bit TXEN. If bit SREN is set (to interrupt an on-going transmission and receive a single word), then after the single word is received, bit SREN will be cleared and the serial port will revert back to transmitting since bit TXEN is still set. The DT line will immediately switch from Hi-impedance Receive mode to transmit and start driving. To avoid this, bit TXEN should be cleared.

In order to select 9-bit transmission, the TX9 (TXSTA<6>) bit should be set and the ninth bit should be written to bit TX9D (TXSTA<0>). The ninth bit must be written before writing the 8-bit data to the TXREG register. This is because a data write to the TXREG can result in an immediate transfer of the data to the TSR register (if the TSR is empty). If the TSR was empty and the TXREG was written before writing the "new" TX9D, the "present" value of bit TX9D is loaded.

Steps to follow when setting up a Synchronous Master Transmission:

1. Initialize the SPBRG register for the appropriate baud rate (Section 12.1).
2. Enable the synchronous master serial port by setting bits SYNC, SPEN, and CSRC.
3. If interrupts are desired, then set enable bit TXIE.
4. If 9-bit transmission is desired, then set bit TX9.
5. Enable the transmission by setting bit TXEN.
6. If 9-bit transmission is selected, the ninth bit should be loaded in bit TX9D.
7. Start transmission by loading data to the TXREG register.

PIC16F62X

TABLE 12-9: REGISTERS ASSOCIATED WITH SYNCHRONOUS MASTER TRANSMISSION

Address	Name	Bit 7	Bit 6	Bit 5	Bit 4	Bit 3	Bit 2	Bit 1	Bit 0	Value on POR	Value on all other RESETS
0Ch	PIR1	EEIF	CMIF	RCIF	TXIF	—	CCP1IF	TMR2IF	TMR1IF	0000 -000	0000 -000
18h	RCSTA	SPEN	RX9	SREN	CREN	ADEN	FERR	OERR	RX9D	0000 -00x	0000 -00x
19h	TXREG	USART Transmit Register								0000 0000	0000 0000
8Ch	PIE1	EEIE	CMIE	RCIE	TXIE	—	CCP1IE	TMR2IE	TMR1IE	0000 -000	0000 -000
98h	TXSTA	CSRC	TX9	TXEN	SYNC	—	BRGH	TRMT	TX9D	0000 -010	0000 -010
99h	SPBRG	Baud Rate Generator Register								0000 0000	0000 0000

Legend: x = unknown, - = unimplemented, read as '0'. Shaded cells are not used for Synchronous Master Transmission.

FIGURE 12-12: SYNCHRONOUS TRANSMISSION

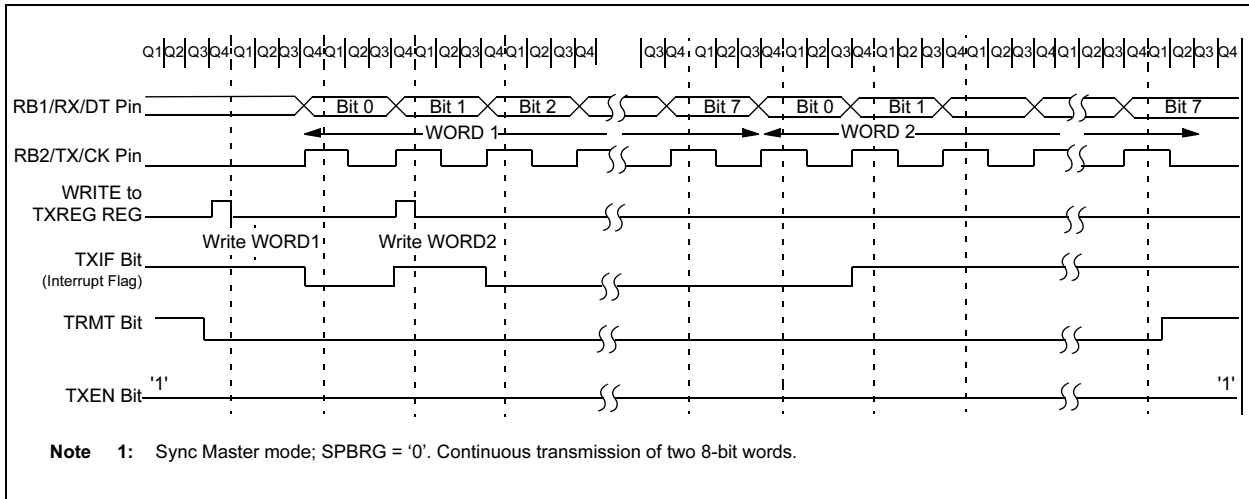
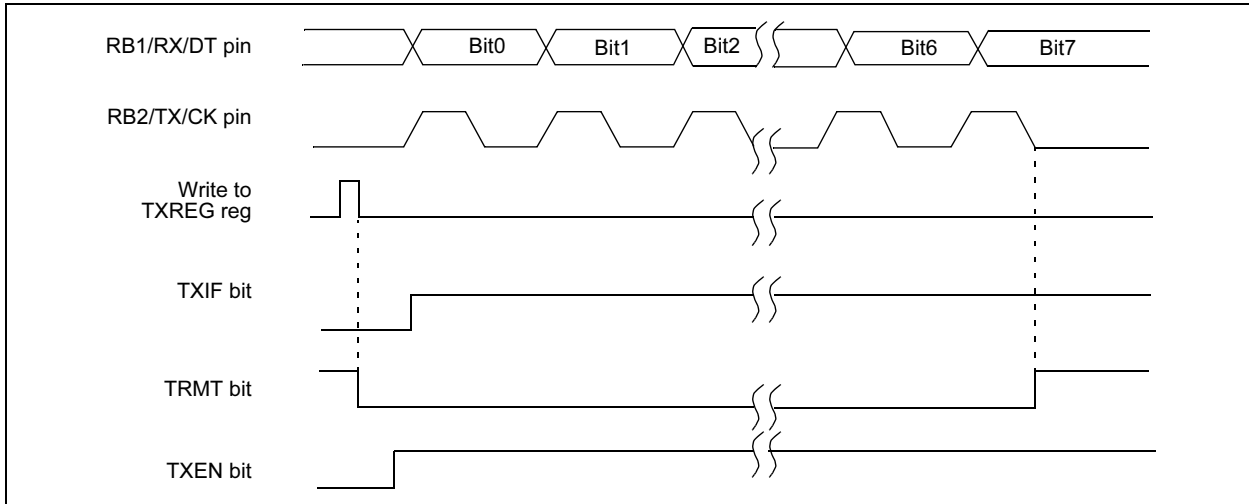

FIGURE 12-13: SYNCHRONOUS TRANSMISSION (THROUGH TXEN)



12.4.2 USART SYNCHRONOUS MASTER RECEPTION

Once Synchronous mode is selected, reception is enabled by setting either enable bit SREN (RCSTA<5>) or enable bit CREN (RCSTA<4>). Data is sampled on the RB1/RX/DT pin on the falling edge of the clock. If enable bit SREN is set, then only a single word is received. If enable bit CREN is set, the reception is continuous until CREN is cleared. If both bits are set, then CREN takes precedence. After clocking the last bit, the received data in the Receive Shift Register (RSR) is transferred to the RCREG register (if it is empty). When the transfer is complete, interrupt flag bit RCIF (PIR1<5>) is set. The actual interrupt can be enabled/disabled by setting/clearing enable bit RCIE (PIE1<5>). Flag bit RCIF is a read only bit which is RESET by the hardware. In this case, it is RESET when the RCREG register has been read and is empty. The RCREG is a double buffered register (i.e., it is a two-deep FIFO). It is possible for two bytes of data to be received and transferred to the RCREG FIFO and a third byte to begin shifting into the RSR register. On the clocking of the last bit of the third byte, if the RCREG register is still full then overrun error bit OERR (RCSTA<1>) is set. The word in the RSR will be lost. The RCREG register can be read twice to retrieve the two bytes in the FIFO. Bit OERR has to be cleared in software (by clearing bit CREN). If bit OERR is set, transfers from the RSR to the RCREG are inhibited, so it is essential to clear bit OERR if it is set. The 9th

receive bit is buffered the same way as the receive data. Reading the RCREG register, will load bit RX9D with a new value, therefore it is essential for the user to read the RCSTA register before reading RCREG in order not to lose the old RX9D information.

Steps to follow when setting up a Synchronous Master Reception:

1. Initialize the SPBRG register for the appropriate baud rate. (Section 12.1)
2. Enable the synchronous master serial port by setting bits SYNC, SPEN, and CSRC.
3. Ensure bits CREN and SREN are clear.
4. If interrupts are desired, then set enable bit RCIE.
5. If 9-bit reception is desired, then set bit RX9.
6. If a single reception is required, set bit SREN. For continuous reception set bit CREN.
7. Interrupt flag bit RCIF will be set when reception is complete and an interrupt will be generated if enable bit RCIE was set.
8. Read the RCSTA register to get the ninth bit (if enabled) and determine if any error occurred during reception.
9. Read the 8-bit received data by reading the RCREG register.
10. If any error occurred, clear the error by clearing bit CREN.

TABLE 12-10: REGISTERS ASSOCIATED WITH SYNCHRONOUS MASTER RECEPTION

Address	Name	Bit 7	Bit 6	Bit 5	Bit 4	Bit 3	Bit 2	Bit 1	Bit 0	Value on: POR	Value on all other RESETS
0Ch	PIR1	EEIF	CMIF	RCIF	TXIF	—	CCP1IF	TMR2IF	TMR1IF	0000 -000	0000 -000
18h	RCSTA	SPEN	RX9	SREN	CREN	ADEN	FERR	OERR	RX9D	0000 -00x	0000 -00x
1Ah	RCREG	USART Receive Register								0000 0000	0000 0000
8Ch	PIE1	EEPIE	CMIE	RCIE	TXIE	—	CCP1IE	TMR2IE	TMR1IE	-000 0000	-000 -000
98h	TXSTA	CSRC	TX9	TXEN	SYNC	—	BRGH	TRMT	TX9D	0000 -010	0000 -010
99h	SPBRG	Baud Rate Generator Register								0000 0000	0000 0000

Legend: x = unknown, - = unimplemented read as '0'. Shaded cells are not used for Synchronous Master Reception.

PIC16F62X

FIGURE 12-14: SYNCHRONOUS RECEPTION (MASTER MODE, SREN)

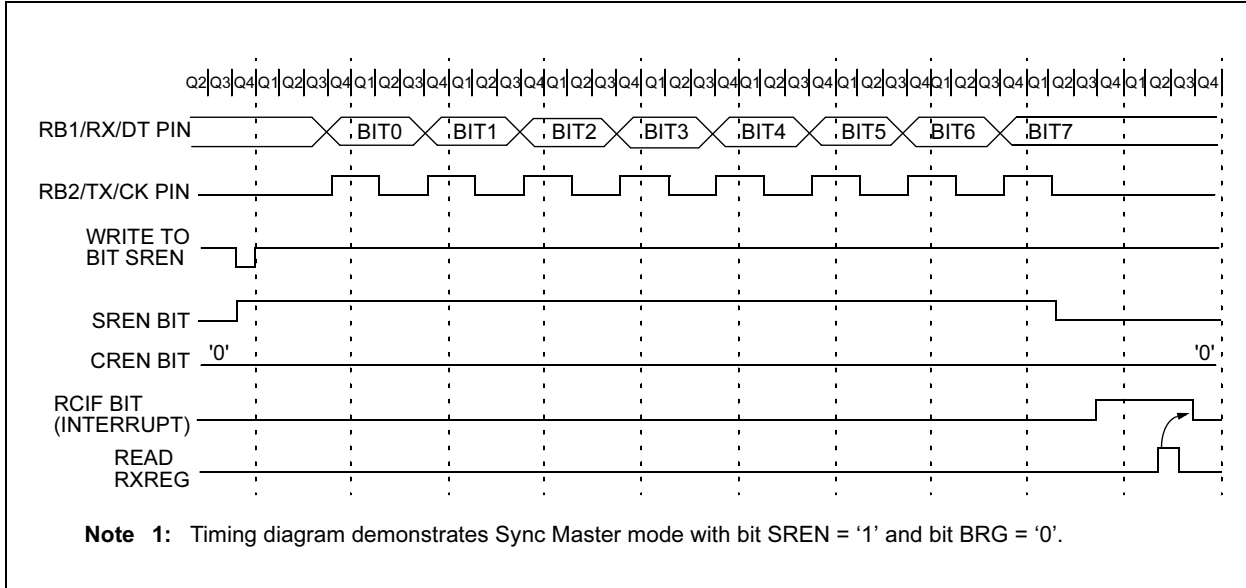

12.5 USART Synchronous Slave Mode

Synchronous Slave mode differs from the Master mode in the fact that the shift clock is supplied externally at the RB2/TX/CK pin (instead of being supplied internally in Master mode). This allows the device to transfer or receive data while in SLEEP mode. Slave mode is entered by clearing bit CSRC (TXSTA<7>).

12.5.1 USART SYNCHRONOUS SLAVE TRANSMIT

The operation of the Synchronous Master and Slave modes are identical except in the case of the SLEEP mode.

If two words are written to the TXREG and then the SLEEP instruction is executed, the following will occur:

- The first word will immediately transfer to the TSR register and transmit.
- The second word will remain in TXREG register.
- Flag bit TXIF will not be set.
- When the first word has been shifted out of TSR, the TXREG register will transfer the second word to the TSR and flag bit TXIF will now be set.
- If enable bit TXIE is set, the interrupt will wake the chip from SLEEP and if the global interrupt is enabled, the program will branch to the interrupt vector (0004h).

Steps to follow when setting up a Synchronous Slave Transmission:

- Enable the synchronous slave serial port by setting bits SYNC and SPEN and clearing bit CSRC.
- Clear bits CREN and SREN.
- If interrupts are desired, then set enable bit TXIE.
- If 9-bit transmission is desired, then set bit TX9.
- Enable the transmission by setting enable bit TXEN.
- If 9-bit transmission is selected, the ninth bit should be loaded in bit TX9D.
- Start transmission by loading data to the TXREG register.

12.5.2 USART SYNCHRONOUS SLAVE RECEPTION

The operation of the Synchronous Master and Slave modes is identical except in the case of the SLEEP mode. Also, bit SREN is a don't care in Slave mode.

If receive is enabled, by setting bit CREN, prior to the SLEEP instruction, then a word may be received during SLEEP. On completely receiving the word, the RSR register will transfer the data to the RCREG register and if enable bit RCIE bit is set, the interrupt generated will wake the chip from SLEEP. If the global interrupt is enabled, the program will branch to the interrupt vector (0004h).

Steps to follow when setting up a Synchronous Slave Reception:

1. Enable the synchronous master serial port by

setting bits SYNC and SPEN and clearing bit CSRC.

2. If interrupts are desired, then set enable bit RCIE.
3. If 9-bit reception is desired, then set bit RX9.
4. To enable reception, set enable bit CREN.
5. Flag bit RCIF will be set when reception is complete and an interrupt will be generated, if enable bit RCIE was set.
6. Read the RCSTA register to get the ninth bit (if enabled) and determine if any error occurred during reception.
7. Read the 8-bit received data by reading the RCREG register.
8. If any error occurred, clear the error by clearing bit CREN.

TABLE 12-11: REGISTERS ASSOCIATED WITH SYNCHRONOUS SLAVE TRANSMISSION

Address	Name	Bit 7	Bit 6	Bit 5	Bit 4	Bit 3	Bit 2	Bit 1	Bit 0	Value on POR	Value on all other RESETS
0Ch	PIR1	EEIF	CMIF	RCIF	TXIF	—	CCP1IF	TMR2IF	TMR1IF	0000 -000	0000 -000
18h	RCSTA	SPEN	RX9	SREN	CREN	ADEN	FERR	OERR	RX9D	0000 -00x	0000 -00x
19h	TXREG	USART Transmit Register								0000 0000	0000 0000
8Ch	PIE1	EEIE	CMIE	RCIE	TXIE	—	CCP1IE	TMR2IE	TMR1IE	0000 -000	0000 -000
98h	TXSTA	CSRC	TX9	TXEN	SYNC	—	BRGH	TRMT	TX9D	0000 -010	0000 -010
99h	SPBRG	Baud Rate Generator Register								0000 0000	0000 0000

Legend: x = unknown, - = unimplemented read as '0'. Shaded cells are not used for Synchronous Slave Transmission.

TABLE 12-12: REGISTERS ASSOCIATED WITH SYNCHRONOUS SLAVE RECEPTION

Address	Name	Bit 7	Bit 6	Bit 5	Bit 4	Bit 3	Bit 2	Bit 1	Bit 0	Value on POR	Value on all other RESETS
0Ch	PIR1	EEIF	CMIF	RCIF	TXIF	—	CCP1IF	TMR2IF	TMR1IF	0000 -000	0000 -000
18h	RCSTA	SPEN	RX9	SREN	CREN	ADEN	FERR	OERR	RX9D	0000 -00x	0000 -00x
1Ah	RCREG	USART Receive Register								0000 0000	0000 0000
8Ch	PIE1	EEIE	CMIE	RCIE	TXIE	—	CCP1IE	TMR2IE	TMR1IE	0000 -000	0000 -000
98h	TXSTA	CSRC	TX9	TXEN	SYNC	—	BRGH	TRMT	TX9D	0000 -010	0000 -010
99h	SPBRG	Baud Rate Generator Register								0000 0000	0000 0000

Legend: x = unknown, - = unimplemented read as '0'. Shaded cells are not used for Synchronous Slave Reception.

PIC16F62X

NOTES:

13.0 DATA EEPROM MEMORY

The EEPROM data memory is readable and writable during normal operation (full VDD range). This memory is not directly mapped in the register file space. Instead it is indirectly addressed through the Special Function Registers (SFRs). There are four SFRs used to read and write this memory. These registers are:

- EECON1
- EECON2 (Not a physically implemented register)
- EEDATA
- EEADR

EEDATA holds the 8-bit data for read/write, and EEADR holds the address of the EEPROM location being accessed. PIC16F62X devices have 128 bytes of data EEPROM with an address range from 0h to 7Fh.

The EEPROM data memory allows byte read and write. A byte write automatically erases the location and writes the new data (erase before write). The EEPROM data memory is rated for high erase/write cycles. The write time is controlled by an on-chip timer. The write-time will vary with voltage and temperature as well as from chip to chip. Please refer to AC specifications for exact limits.

When the device is code protected, the CPU may continue to read and write the data EEPROM memory. The device programmer can no longer access this memory.

Additional information on the Data EEPROM is available in the PICmicro™ Mid-Range Reference Manual, (DS33023).

REGISTER 13-1: EEADR REGISTER (ADDRESS: 9Bh)

R/W	R/W	R/W	R/W	R/W	R/W	R/W	R/W
Reserved	EADR6	EADR5	EADR4	EADR3	EADR2	EADR1	EADR0
bit 7							bit 0

bit 7 **Unimplemented Address:** Must be set to '0'

bit 6-0 **EEADR:** Specifies one of 128 locations of EEPROM Read/Write Operation

Legend:

R = Readable bit

W = Writable bit

U = Unimplemented bit, read as '0'

-n = Value at POR

'1' = Bit is set

'0' = Bit is cleared

x = Bit is unknown

13.1 EEADR

The EEADR register can address up to a maximum of 256 bytes of data EEPROM. Only the first 128 bytes of data EEPROM are implemented and only seven of the eight bits in the register (EEADR<6:0>) are required.

The upper bit is address decoded. This means that this bit should always be '0' to ensure that the address is in the 128 byte memory space.

The WREN bit, when set, will allow a write operation. On power-up, the WREN bit is clear. The WRERR bit is set when a write operation is interrupted by a MCLR Reset or a WDT Timeout Reset during normal operation. In these situations, following RESET, the user can check the WRERR bit and rewrite the location. The data and address will be unchanged in the EEDATA and EEADR registers.

Interrupt flag bit EEIF in the PIR1 register is set when write is complete. This bit must be cleared in software.

13.2 EECON1 AND EECON2 REGISTERS

EECON1 is the control register with five low order bits physically implemented. The upper-three bits are non-existent and read as '0's.

Control bits RD and WR initiate read and write, respectively. These bits cannot be cleared, only set, in software. They are cleared in hardware at completion of the read or write operation. The inability to clear the WR bit in software prevents the accidental, premature termination of a write operation.

EECON2 is not a physical register. Reading EECON2 will read all '0's. The EECON2 register is used exclusively in the Data EEPROM write sequence.

PIC16F62X

REGISTER 13-2: EECON1 REGISTER (ADDRESS: 9Ch)

U-0	U-0	U-0	U-0	R/W-x	R/W-0	R/S-0	R/S-x
—	—	—	—	WRERR	WREN	WR	RD
bit 7				bit 0			

bit 7-4 **Unimplemented:** Read as '0'

bit 3 **WRERR:** EEPROM Error Flag bit

1 = A write operation is prematurely terminated (any $\overline{\text{MCLR}}$ Reset, any WDT Reset during normal operation or BOD Reset)

0 = The write operation completed

bit 2 **WREN:** EEPROM Write Enable bit

1 = Allows write cycles

0 = Inhibits write to the data EEPROM

bit 1 **WR:** Write Control bit

1 = Initiates a write cycle. (The bit is cleared by hardware once write is complete. The WR bit can only be set (not cleared) in software.)

0 = Write cycle to the data EEPROM is complete

bit 0 **RD:** Read Control bit

1 = Initiates an EEPROM read (read takes one cycle. RD is cleared in hardware. The RD bit can only be set (not cleared) in software.)

0 = Does not initiate an EEPROM read

Legend:

R = Readable bit

W = Writable bit

U = Unimplemented bit, read as '0'

-n = Value at POR

'1' = Bit is set

'0' = Bit is cleared

x = Bit is unknown

13.3 READING THE EEPROM DATA MEMORY

To read a data memory location, the user must write the address to the EEADR register and then set control bit RD (EECON1<0>). The data is available, in the very next cycle, in the EEDATA register; therefore it can be read in the next instruction. EEDATA will hold this value until another read or until it is written to by the user (during a write operation).

EXAMPLE 13-1: DATA EEPROM READ

```
BSF    STATUS, RP0    ; Bank 1
MOVLW  CONFIG_ADDR   ;
MOVWF  EEADR         ; Address to read
BSF    EECON1, RD    ; EE Read
MOVF   EEDATA, W     ; W = EEDATA
BCF    STATUS, RP0   ; Bank 0
```

13.4 WRITING TO THE EEPROM DATA MEMORY

To write an EEPROM data location, the user must first write the address to the EEADR register and the data to the EEDATA register. Then the user must follow a specific sequence to initiate the write for each byte.

EXAMPLE 13-2: DATA EEPROM WRITE

Required Sequence	BSF	STATUS, RP0	; Bank 1
	BSF	EECON1, WREN	; Enable write
	BCF	INTCON, GIE	; Disable INTs.
	MOVLW	55h	;
	MOVWF	EECON2	; Write 55h
	MOVLW	AAh	;
	MOVWF	EECON2	; Write AAh
	BSF	EECON1, WR	; Set WR bit
			; begin write
	BSF	INTCON, GIE	; Enable INTs.

The write will not initiate if the above sequence is not exactly followed (write 55h to EECON2, write AAh to EECON2, then set WR bit) for each byte. We strongly recommend that interrupts be disabled during this code segment. A cycle count is executed during the required sequence. Any number that is not equal to the required cycles to execute the required sequence will cause the data not to be written into the EEPROM.

Additionally, the WREN bit in EECON1 must be set to enable write. This mechanism prevents accidental writes to data EEPROM due to errant (unexpected) code execution (i.e., lost programs). The user should keep the WREN bit clear at all times, except when updating EEPROM. The WREN bit is not cleared by hardware.

After a write sequence has been initiated, clearing the WREN bit will not affect this write cycle. The WR bit will be inhibited from being set unless the WREN bit is set.

At the completion of the write cycle, the WR bit is cleared in hardware and the EE Write Complete Interrupt Flag bit (EEIF) is set. The user can either enable this interrupt or poll this bit. The EEIF bit in the PIR1 registers must be cleared by software.

13.5 WRITE VERIFY

Depending on the application, good programming practice may dictate that the value written to the Data EEPROM should be verified (Example 13-3) to the desired value to be written. This should be used in applications where an EEPROM bit will be stressed near the specification limit.

EXAMPLE 13-3: WRITE VERIFY

```
BSF    STATUS, RP0    ; Bank 1
MOVF   EEDATA, W     ;
BSF    EECON1, RD    ; Read the
                                ; value written
;
; Is the value written (in W reg) and
; read (in EEDATA) the same?
;
SUBWF  EEDATA, W     ;
BCF    STATUS, RP0   ; Bank 0
BTFSS  STATUS, Z     ; Is difference 0?
GOTO   WRITE_ERR    ; NO, Write error
:      ; YES, Good write
:      ; Continue program
```

13.6 PROTECTION AGAINST SPURIOUS WRITE

There are conditions when the device may not want to write to the data EEPROM memory. To protect against spurious EEPROM writes, various mechanisms have been built in. On power-up, WREN is cleared. Also, the Power-up Timer (72 ms duration) prevents EEPROM write.

The write initiate sequence, and the WREN bit together help prevent an accidental write during brown-out, power glitch, or software malfunction.

13.7 DATA EEPROM OPERATION DURING CODE PROTECT

When the device is code protected, the CPU is able to read and write unscrambled data to the Data EEPROM.

PIC16F62X

TABLE 13-1: REGISTERS/BITS ASSOCIATED WITH DATA EEPROM

Address	Name	Bit 7	Bit 6	Bit 5	Bit 4	Bit 3	Bit 2	Bit 1	Bit 0	Value on Power-on Reset	Value on all other RESETS
9Ah	EEDATA	EEPROM data register								xxxx xxxx	uuuu uuuu
9Bh	EEADR	EEPROM address register								xxxx xxxx	uuuu uuuu
9Ch	EECON1	—	—	—	—	WRERR	WREN	WR	RD	---- x000	---- q000
9Dh	EECON2 ⁽¹⁾	EEPROM control register 2								---- ----	---- ----

Legend: x = unknown, u = unchanged, - = unimplemented read as '0', q = value depends upon condition.
 Shaded cells are not used by data EEPROM.

Note 1: EECON2 is not a physical register

14.0 SPECIAL FEATURES OF THE CPU

Special circuits to deal with the needs of real-time applications are what sets a microcontroller apart from other processors. The PIC16F62X family has a host of such features intended to maximize system reliability, minimize cost through elimination of external components, provide power saving Operating modes and offer code protection.

These are:

1. OSC selection
2. RESET
3. Power-on Reset (POR)
4. Power-up Timer (PWRT)
5. Oscillator Start-Up Timer (OST)
6. Brown-out Reset (BOD)
7. Interrupts
8. Watchdog Timer (WDT)
9. SLEEP
10. Code protection
11. ID Locations
12. In-circuit Serial Programming

The PIC16F62X has a Watchdog Timer which is controlled by configuration bits. It runs off its own RC oscillator for added reliability. There are two timers that offer necessary delays on power-up. One is the Oscillator Start-up Timer (OST), intended to keep the chip in RESET until the crystal oscillator is stable. The other is the Power-up Timer (PWRT), which provides a fixed delay of 72 ms (nominal) on power-up only, designed to keep the part in RESET while the power supply stabilizes. There is also circuitry to RESET the device if a Brown-out occurs, which provides at least a 72 ms RESET. With these three functions on-chip, most applications need no external RESET circuitry.

The SLEEP mode is designed to offer a very low current Power-down mode. The user can wake-up from SLEEP through external RESET, Watchdog Timer wake-up or through an interrupt. Several oscillator options are also made available to allow the part to fit the application. The ER oscillator option saves system cost while the LP crystal option saves power. A set of configuration bits are used to select various options.

14.1 Configuration Bits

The configuration bits can be programmed (read as '0') or left unprogrammed (read as '1') to select various device configurations. These bits are mapped in program memory location 2007h.

The user will note that address 2007h is beyond the user program memory space. In fact, it belongs to the special configuration memory space (2000h – 3FFFh), which can be accessed only during programming. See Programming Specification.

PIC16F62X

REGISTER 14-1: CONFIGURATION WORD

CP1	CP0	CP1	CP0	—	CPD	LVP	BODEN	MCLR \overline{E}	FOSC2	\overline{PWRTE}	WDTE	FOSC1	FOSC0
bit 13											bit 0		

- bit 13-10: **CP1:CP0:** Code Protection bits ⁽²⁾
 Code protection for 2K program memory
 11 = Program memory code protection off
 10 = 0400h-07FFh code protected
 01 = 0200h-07FFh code protected
 00 = 0000h-07FFh code protected
- Code protection for 1K program memory
 11 = Program memory code protection off
 10 = Program memory code protection off
 01 = 0200h-03FFh code protected
 00 = 0000h-03FFh code protected
- bit 9: **Unimplemented:** Read as '0'
- bit 8: **CPD:** Data Code Protection bit ⁽³⁾
 1 = Data memory code protection off
 0 = Data memory code protected
- bit 7: **LVP:** Low Voltage Programming Enable
 1 = RB4/PGM pin has PGM function, low voltage programming enabled
 0 = RB4/PGM is digital I/O, HV on \overline{MCLR} must be used for programming
- bit 6: **BODEN:** Brown-out Detect Reset Enable bit ⁽¹⁾
 1 = BOD Reset enabled
 0 = BOD Reset disabled
- bit 5: **MCLR \overline{E} :** RA5/ \overline{MCLR} pin function select
 1 = RA5/ \overline{MCLR} pin function is \overline{MCLR}
 0 = RA5/ \overline{MCLR} pin function is digital Input, \overline{MCLR} internally tied to VDD
- bit 3: **\overline{PWRTE} :** Power-up Timer Enable bit ⁽¹⁾
 1 = PWRT disabled
 0 = PWRT enabled
- bit 2: **WDTEN:** Watchdog Timer Enable bit
 1 = WDT enabled
 0 = WDT disabled
- bit 4, 1-0: **FOSC2:FOSC0:** Oscillator Selection bits ⁽⁴⁾
 111 = ER oscillator: CLKOUT function on RA6/OSC2/CLKOUT pin, Resistor on RA7/OSC1/CLKIN
 110 = ER oscillator: I/O function on RA6/OSC2/CLKOUT pin, Resistor on RA7/OSC1/CLKIN
 101 = INTRC oscillator: CLKOUT function on RA6/OSC2/CLKOUT pin, I/O function on RA7/OSC1/CLKIN
 100 = INTRC oscillator: I/O function on RA6/OSC2/CLKOUT pin, I/O function on RA7/OSC1/CLKIN
 011 = EC: I/O function on RA6/OSC2/CLKOUT pin, CLKIN on RA7/OSC1/CLKIN
 010 = HS oscillator: High speed crystal/resonator on RA6/OSC2/CLKOUT and RA7/OSC1/CLKIN
 001 = XT oscillator: Crystal/resonator on RA6/OSC2/CLKOUT and RA7/OSC1/CLKIN
 000 = LP oscillator: Low power crystal on RA6/OSC2/CLKOUT and RA7/OSC1/CLKIN
- Note** 1: Enabling Brown-out Detect Reset automatically enables Power-up Timer (PWRT) regardless of the value of bit \overline{PWRTE} . Ensure the Power-up Timer is enabled anytime Brown-out Detect Reset is enabled.
 2: All of the CP1:CP0 pairs have to be given the same value to enable the code protection scheme listed.
 3: The entire data EEPROM will be erased when the code protection is turned off.
 4: When \overline{MCLR} is asserted in INTRC or ER mode, the internal clock oscillator is disabled.

Legend

R = Readable bit	W = Writable bit	U = Unimplemented bit, read as '0'
-n = Value at POR	1 = bit is set	0 = bit is cleared
		x = bit is unknown

14.2 Oscillator Configurations

14.2.1 OSCILLATOR TYPES

The PIC16F62X can be operated in eight different oscillator options. The user can program three configuration bits (FOSC2 thru FOSC0) to select one of these eight modes:

- LP Low Power Crystal
- XT Crystal/Resonator
- HS High Speed Crystal/Resonator
- ER External Resistor (2 modes)
- INTRC Internal Resistor/Capacitor (2 modes)
- EC External Clock In

14.2.2 CRYSTAL OSCILLATOR / CERAMIC RESONATORS

In XT, LP or HS modes a crystal or ceramic resonator is connected to the OSC1 and OSC2 pins to establish oscillation (Figure 14-1). The PIC16F62X oscillator design requires the use of a parallel cut crystal. Use of a series cut crystal may give a frequency out of the crystal manufacturers specifications. When in XT, LP or HS modes, the device can have an external clock source to drive the OSC1 pin (Figure 14-4).

FIGURE 14-1: CRYSTAL OPERATION (OR CERAMIC RESONATOR) (HS, XT OR LP OSC CONFIGURATION)

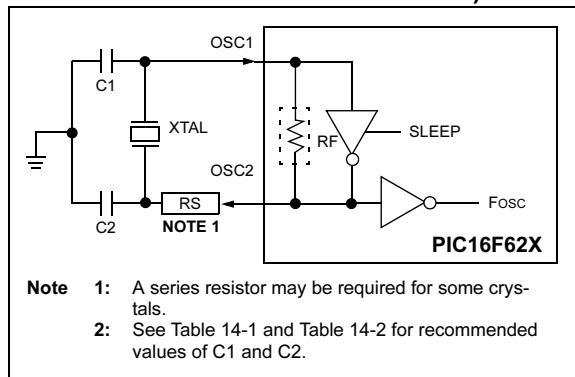

TABLE 14-1: CAPACITOR SELECTION FOR CERAMIC RESONATORS

Ranges Characterized:			
Mode	Freq	OSC1(C1)	OSC2(C2)
XT	455 kHz	22 - 100 pF	22 - 100 pF
	2.0 MHz	15 - 68 pF	15 - 68 pF
	4.0 MHz	15 - 68 pF	15 - 68 pF
HS	8.0 MHz	10 - 68 pF	10 - 68 pF
	16.0 MHz	10 - 22 pF	10 - 22 pF

Note 1: Higher capacitance increases the stability of the oscillator but also increases the start-up time. These values are for design guidance only. Since each resonator has its own characteristics, the user should consult the resonator manufacturer for appropriate values of external components.

TABLE 14-2: CAPACITOR SELECTION FOR CRYSTAL OSCILLATOR

Mode	Freq	OSC1(C1)	OSC2(C2)
LP	32 kHz	68 - 100 pF	68 - 100 pF
	200 kHz	15 - 30 pF	15 - 30 pF
XT	100 kHz	68 - 150 pF	150 - 200 pF
	2 MHz	15 - 30 pF	15 - 30 pF
	4 MHz	15 - 30 pF	15 - 30 pF
HS	8 MHz	15 - 30 pF	15 - 30 pF
	10 MHz	15 - 30 pF	15 - 30 pF
	20 MHz	15 - 30 pF	15 - 30 pF

Note 1: Higher capacitance increases the stability of the oscillator but also increases the start-up time. These values are for design guidance only. Rs may be required in HS mode as well as XT mode to avoid overdriving crystals with low drive level specification. Since each crystal has its own characteristics, the user should consult the crystal manufacturer for appropriate values of external components.

14.2.3 EXTERNAL CRYSTAL OSCILLATOR CIRCUIT

Either a prepackaged oscillator can be used, or a simple oscillator circuit with TTL gates can be built. Prepackaged oscillators provide a wide operating range and better stability. A well-designed crystal oscillator will provide good performance with TTL gates. Two types of crystal oscillator circuits can be used; one with series resonance, or one with parallel resonance.

Figure 14-2 shows implementation of a parallel resonant oscillator circuit. The circuit is designed to use the fundamental frequency of the crystal. The 74AS04 inverter performs the 180° phase shift that a parallel oscillator requires. The 4.7 kΩ resistor provides the negative feedback for stability. The 10 kΩ potentiometers bias the 74AS04 in the linear region. This could be used for external oscillator designs.

PIC16F62X

FIGURE 14-2: EXTERNAL PARALLEL RESONANT CRYSTAL OSCILLATOR CIRCUIT

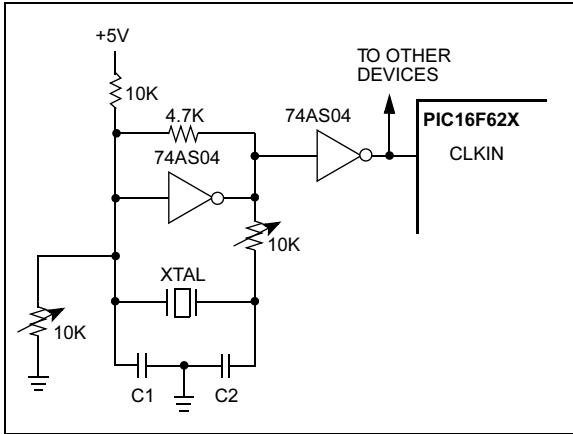
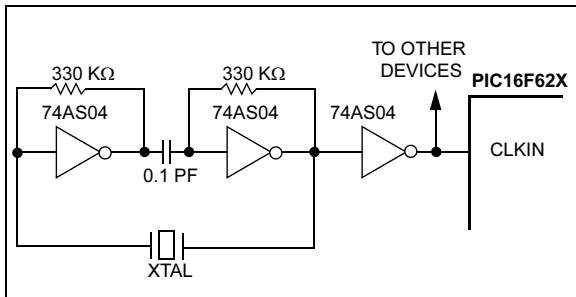

Figure 14-3 shows a series resonant oscillator circuit. This circuit is also designed to use the fundamental frequency of the crystal. The inverter performs a 180° phase shift in a series resonant oscillator circuit. The 330 kΩ resistors provide the negative feedback to bias the inverters in their linear region.

FIGURE 14-3: EXTERNAL SERIES RESONANT CRYSTAL OSCILLATOR CIRCUIT



14.2.4 EXTERNAL CLOCK IN

For applications, where a clock is already available elsewhere, users may directly drive the PIC16F62X provided that this external clock source meets the AC/DC timing requirements listed in Section 17.4. Figure 14-4 shows how an external clock circuit should be configured.

FIGURE 14-4: EXTERNAL CLOCK INPUT OPERATION (EC, HS, XT OR LP OSC CONFIGURATION)

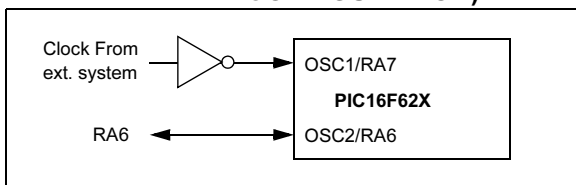

14.2.5 ER OSCILLATOR

For timing insensitive applications, the ER (External Resistor) Clock mode offers additional cost savings. Only one external component, a resistor to VSS, is needed to set the operating frequency of the internal oscillator. The resistor draws a DC bias current which controls the oscillation frequency. In addition to the resistance value, the oscillator frequency will vary from unit to unit, and as a function of supply voltage and temperature. Since the controlling parameter is a DC current and not a capacitance, the particular package type and lead frame will not have a significant effect on the resultant frequency.

Figure 14-5 shows how the controlling resistor is connected to the PIC16F62X. For REXT values below 10k, the oscillator operation becomes sensitive to temperature. For very high REXT values (e.g., 1M), the oscillator becomes sensitive to leakage and may stop completely. Thus, we recommend keeping REXT between 10k and 1M.

FIGURE 14-5: EXTERNAL RESISTOR

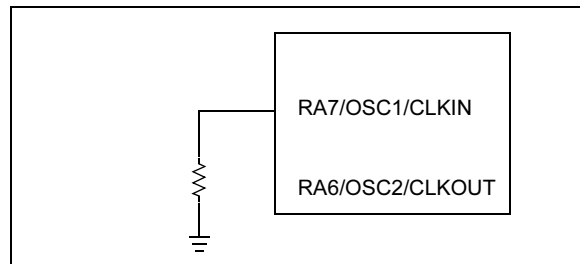

Table 14-3 shows the relationship between the resistance value and the operating frequency.

TABLE 14-3: RESISTANCE AND FREQUENCY RELATIONSHIP

Resistance	Frequency
0	10.4 MHz
1K	10 MHz
10K	7.4 MHz
20K	5.3 MHz
47K	3 MHz
100K	1.6 MHz
220K	800 kHz
470K	300 kHz
1M	200 kHz

The ER Oscillator mode has two options that control the unused OSC2 pin. The first allows it to be used as a general purpose I/O port. The other configures the pin as an output providing the Fosc signal (internal clock divided by 4) for test or external synchronization purposes.

14.2.6 INTERNAL 4 MHz OSCILLATOR

The internal RC oscillator provides a fixed 4 MHz (nominal) system clock at $V_{DD} = 5V$ and $25^{\circ}C$, see “Electrical Specifications” section for information on variation over voltage and temperature.

14.2.7 CLKOUT

The PIC16F62X can be configured to provide a clock out signal by programming the configuration word. The oscillator frequency, divided by 4 can be used for test purposes or to synchronize other logic.

14.3 Special Feature: Dual Speed Oscillator Modes

A software programmable Dual Speed Oscillator mode is provided when the PIC16F62X is configured in either ER or INTRC Oscillator modes. This feature allows users to dynamically toggle the oscillator speed between 4 MHz and 37 kHz. In ER mode, the 4 MHz setting will vary depending on the value of the external resistor. Also in ER mode, the 37 kHz operation is fixed and does not vary with resistor value. Applications that require low current power savings, but cannot tolerate putting the part into SLEEP, may use this mode.

The OSCF bit in the PCON register is used to control Dual Speed mode. See Section 3.2.2.6, Register 3-4.

14.4 RESET

The PIC16F62X differentiates between various kinds of RESET:

- Power-on Reset (POR)
- \overline{MCLR} Reset during normal operation
- \overline{MCLR} Reset during SLEEP
- WDT Reset (normal operation)
- WDT Wake-up (SLEEP)
- Brown-out Detect (BOD)

Some registers are not affected in any RESET condition; their status is unknown on POR and unchanged in any other RESET. Most other registers are reset to a “RESET state” on Power-on Reset, \overline{MCLR} Reset, WDT Reset and \overline{MCLR} Reset during SLEEP. They are not affected by a WDT Wake-up, since this is viewed as the resumption of normal operation. \overline{TO} and \overline{PD} bits are set or cleared differently in different RESET situations as indicated in Table 14-5. These bits are used in software to determine the nature of the RESET. See Table 14-8 for a full description of RESET states of all registers.

A simplified block diagram of the on-chip RESET circuit is shown in Figure 14-6.

The \overline{MCLR} Reset path has a noise filter to detect and ignore small pulses. See Table 17-6 for pulse width specification.

FIGURE 14-6: SIMPLIFIED BLOCK DIAGRAM OF ON-CHIP RESET CIRCUIT

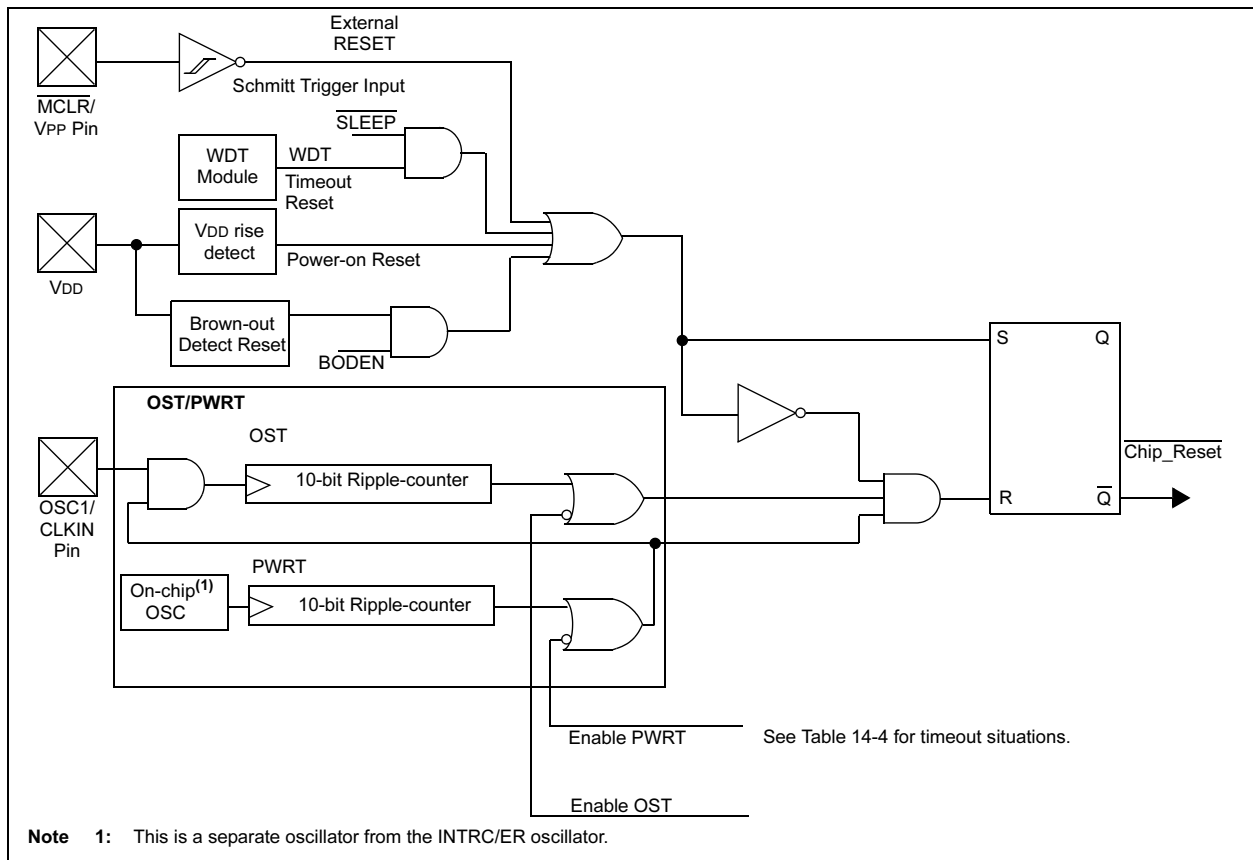

PIC16F62X

14.5 Power-on Reset (POR), Power-up Timer (PWRT), Oscillator Start-up Timer (OST) and Brown-out Detect (BOD)

14.5.1 POWER-ON RESET (POR)

The on-chip POR circuit holds the chip in RESET until VDD has reached a high enough level for proper operation. To take advantage of the POR, just tie the MCLR pin through a resistor to VDD. This will eliminate external RC components usually needed to create Power-on Reset. A maximum rise time for VDD is required. See Electrical Specifications for details.

The POR circuit does not produce an internal RESET when VDD declines.

When the device starts normal operation (exits the RESET condition), device operating parameters (voltage, frequency, temperature, etc.) must be met to ensure operation. If these conditions are not met, the device must be held in RESET until the operating conditions are met.

For additional information, refer to Application Note AN607, "Power-up Trouble Shooting".

14.5.2 POWER-UP TIMER (PWRT)

The PWRT provides a fixed 72 ms (nominal) timeout on power-up only, from POR or Brown-out Detect Reset. The PWRT operates on an internal RC oscillator. The chip is kept in RESET as long as PWRT is active. The PWRT delay allows the VDD to rise to an acceptable level. A configuration bit, PWRTE can disable (if set) or enable (if cleared or programmed) the PWRT. The PWRT should always be enabled when Brown-out Detect Reset is enabled.

The Power-Up Time delay will vary from chip to chip and due to VDD, temperature and process variation. See DC parameters for details.

14.5.3 OSCILLATOR START-UP TIMER (OST)

The OST provides a 1024 oscillator cycle (from OSC1 input) delay after the PWRT delay is over. This ensures that the crystal oscillator or resonator has started and stabilized.

The OST timeout is invoked only for XT, LP and HS modes and only on Power-on Reset or wake-up from SLEEP.

14.5.4 BROWN-OUT DETECT (BOD) RESET

The PIC16F62X members have on-chip BOD circuitry. A configuration bit, BODEN, can disable (if clear/programmed) or enable (if set) the BOD Reset circuitry. If VDD falls below VBOD for longer than TBOD, the brown-out situation will RESET the chip. A RESET is not guaranteed to occur if VDD falls below VBOD for shorter than TBOD. VBOD and TBOD are defined in Table 17-1 and Table 17-6, respectively.

On any RESET (Power-on, Brown-out, Watchdog, etc.) the chip will remain in RESET until VDD rises above VBOD. The Power-up Timer will now be invoked and will keep the chip in RESET an additional 72 ms.

If VDD drops below VBOD while the Power-up Timer is running, the chip will go back into a Brown-out Detect Reset and the Power-up Timer will be re-initialized. Once VDD rises above VBOD, the Power-Up Timer will execute a 72 ms RESET. The Power-up Timer should always be enabled when Brown-out Detect is enabled. Figure 14-7 shows typical Brown-out situations.

FIGURE 14-7: BROWN-OUT SITUATIONS

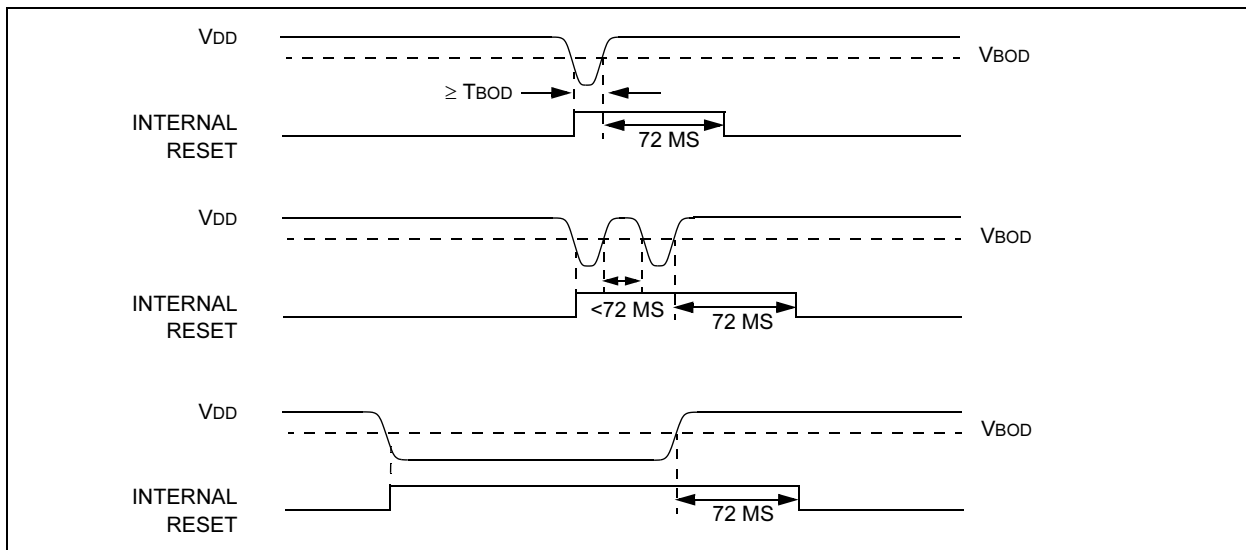

14.5.5 TIMEOUT SEQUENCE

On power-up the timeout sequence is as follows: First PWRT timeout is invoked after POR has expired. Then OST is activated. The total timeout will vary based on oscillator configuration and $\overline{\text{PWRTE}}$ bit status. For example, in ER mode with $\overline{\text{PWRTE}}$ bit erased (PWRT disabled), there will be no timeout at all. Figure 14-8, Figure 14-9 and Figure 14-10 depict timeout sequences.

Since the timeouts occur from the POR pulse, if $\overline{\text{MCLR}}$ is kept low long enough, the timeouts will expire. Then bringing $\overline{\text{MCLR}}$ high will begin execution immediately (see Figure 14-9). This is useful for testing purposes or to synchronize more than one PIC16F62X device operating in parallel.

Table 14-7 shows the RESET conditions for some special registers, while Table 14-8 shows the RESET conditions for all the registers.

14.5.6 POWER CONTROL (PCON) STATUS REGISTER

The Power Control/STATUS register, PCON (address 8Eh) has two bits.

Bit0 is $\overline{\text{BOD}}$ (Brown-out). $\overline{\text{BOD}}$ is unknown on Power-on Reset. It must then be set by the user and checked on subsequent RESETS to see if $\overline{\text{BOD}} = 0$ indicating that a brown-out has occurred. The $\overline{\text{BOD}}$ STATUS bit is a don't care and is not necessarily predictable if the brown-out circuit is disabled (by setting BODEN bit = 0 in the Configuration word).

Bit1 is $\overline{\text{POR}}$ (Power-on Reset). It is a '0' on Power-on Reset and unaffected otherwise. The user must write a '1' to this bit following a Power-on Reset. On a subsequent RESET if $\overline{\text{POR}}$ is '0', it will indicate that a Power-on Reset must have occurred (VDD may have gone too low).

TABLE 14-4: TIMEOUT IN VARIOUS SITUATIONS

Oscillator Configuration	Power-up		Brown-out Detect Reset	Wake-up from SLEEP
	$\overline{\text{PWRTE}} = 0$	$\overline{\text{PWRTE}} = 1$		
XT, HS, LP	72 ms + 1024 Tosc	1024 Tosc	72 ms + 1024 Tosc	1024 Tosc
ER, INTRC, EC	72 ms	—	72 ms	—

TABLE 14-5: STATUS/PCON BITS AND THEIR SIGNIFICANCE

$\overline{\text{POR}}$	$\overline{\text{BOD}}$	$\overline{\text{TO}}$	$\overline{\text{PD}}$	
0	X	1	1	Power-on Reset
0	X	0	X	Illegal, $\overline{\text{TO}}$ is set on $\overline{\text{POR}}$
0	X	X	0	Illegal, $\overline{\text{PD}}$ is set on $\overline{\text{POR}}$
1	0	X	X	Brown-out Detect Reset
1	1	0	u	WDT Reset
1	1	0	0	WDT Wake-up
1	1	u	u	$\overline{\text{MCLR}}$ Reset during normal operation
1	1	1	0	$\overline{\text{MCLR}}$ Reset during SLEEP

Legend: u = unchanged, x = unknown.

TABLE 14-6: SUMMARY OF REGISTERS ASSOCIATED WITH BROWN-OUT

Address	Name	Bit 7	Bit 6	Bit 5	Bit 4	Bit 3	Bit 2	Bit 1	Bit 0	Value on POR Reset	Value on all other RESETS ⁽¹⁾
03h	STATUS	IRP	RP1	RPO	$\overline{\text{TO}}$	$\overline{\text{PD}}$	Z	DC	C	0001 1xxx	000q quuu
8Eh	PCON	—	—	—	—	OSCF	Reset	$\overline{\text{POR}}$	$\overline{\text{BOD}}$	---- 1-0x	---- u-uq

Note 1: Other (non Power-up) Resets include $\overline{\text{MCLR}}$ Reset, Brown-out Detect Reset and Watchdog Timer Reset during normal operation.

PIC16F62X

TABLE 14-7: INITIALIZATION CONDITION FOR SPECIAL REGISTERS

Condition	Program Counter	STATUS Register	PCON Register
Power-on Reset	000h	0001 1xxx	---- 1-0x
MCLR Reset during normal operation	000h	000u uuuu	---- 1-uu
MCLR Reset during SLEEP	000h	0001 0uuu	---- 1-uu
WDT Reset	000h	0000 uuuu	---- 1-uu
WDT Wake-up	PC + 1	uuu0 0uuu	---- u-uu
Brown-out Detect Reset	000h	000x xuuu	---- 1-u0
Interrupt Wake-up from SLEEP	PC + 1 ⁽¹⁾	uuu1 0uuu	---- u-uu

Legend: u = unchanged, x = unknown, - = unimplemented bit, reads as '0'.

Note 1: When the wake-up is due to an interrupt and global enable bit, GIE is set, the PC is loaded with the interrupt vector (0004h) after execution of PC+1.

TABLE 14-8: INITIALIZATION CONDITION FOR REGISTERS

Register	Address	Power-on Reset	<ul style="list-style-type: none"> • MCLR Reset during normal operation • MCLR Reset during SLEEP • WDT Reset • Brown-out Detect Reset ⁽¹⁾ 	<ul style="list-style-type: none"> • Wake-up from SLEEP through interrupt • Wake-up from SLEEP through WDT timeout
W	—	xxxx xxxx	uuuu uuuu	uuuu uuuu
INDF	00h	—	—	—
TMR0	01h	xxxx xxxx	uuuu uuuu	uuuu uuuu
PCL	02h	0000 0000	0000 0000	PC + 1 ⁽³⁾
STATUS	03h	0001 1xxx	000q quuu ⁽⁴⁾	uuuq quuu ⁽⁴⁾
FSR	04h	xxxx xxxx	uuuu uuuu	uuuu uuuu
PORTA	05h	xxxx 0000	xxxx u000	xxxx 0000
PORTB	06h	xxxx xxxx	uuuu uuuu	uuuu uuuu
T1CON	10h	--00 0000	--uu uuuu	--uu uuuu
T2CON	12h	-000 0000	-000 0000	-uuu uuuu
CCP1CON	17h	--00 0000	--00 0000	--uu uuuu
RCSTA	18h	0000 -00x	0000 -00x	uuuu -uuu
CMCON	1Fh	0000 0000	0000 0000	uu-- uuuu
PCLATH	0Ah	---0 0000	---0 0000	---u uuuu
INTCON	0Bh	0000 000x	0000 000u	uuuu uqqq ⁽²⁾
PIR1	0Ch	0000 -000	0000 -000	-q-- ---- ^(2,5)
OPTION	81h	1111 1111	1111 1111	uuuu uuuu
TRISA	85h	11-1 1111	11-- 1111	uu-u uuuu
TRISB	86h	1111 1111	1111 1111	uuuu uuuu
PIE1	8Ch	0000 -000	0000 -000	uuuu -uuu
PCON	8Eh	---- 1-0x	---- 1-uq ^(1,6)	---- --uu
TXSTA	98h	0000 -010	0000 -010	uuuu -uuu
EECON1	9Ch	---- x000	---- q000	---- uuuu
VRCON	9Fh	000- 0000	000- 0000	uuu- uuuu

Legend: u = unchanged, x = unknown, - = unimplemented bit, reads as '0', q = value depends on condition.

Note 1: If VDD goes too low, Power-on Reset will be activated and registers will be affected differently.

Note 2: One or more bits in INTCON, PIR1 and/or PIR2 will be affected (to cause wake-up).

Note 3: When the wake-up is due to an interrupt and the GIE bit is set, the PC is loaded with the interrupt vector (0004h).

Note 4: See Table 14-7 for RESET value for specific condition.

Note 5: If wake-up was due to comparator input changing, then Bit 6 = 1. All other interrupts generating a wake-up will cause Bit 6 = u.

Note 6: If RESET was due to brown-out, then Bit 0 = 0. All other RESETS will cause Bit 0 = u.

FIGURE 14-8: TIMEOUT SEQUENCE ON POWER-UP ($\overline{\text{MCLR}}$ NOT TIED TO V_{DD}): CASE

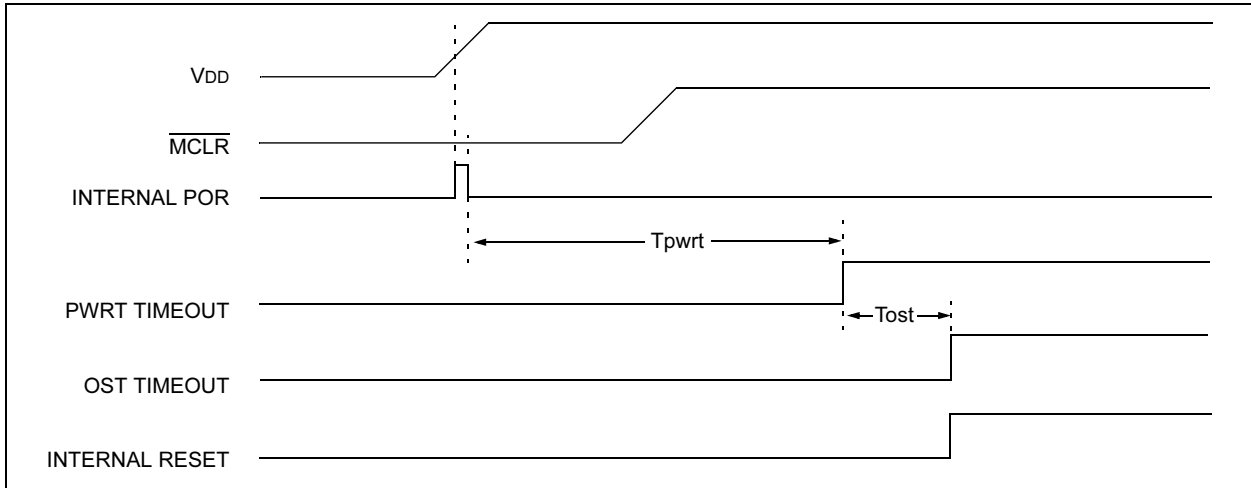

FIGURE 14-9: TIMEOUT SEQUENCE ON POWER-UP ($\overline{\text{MCLR}}$ NOT TIED TO V_{DD}): CASE 2

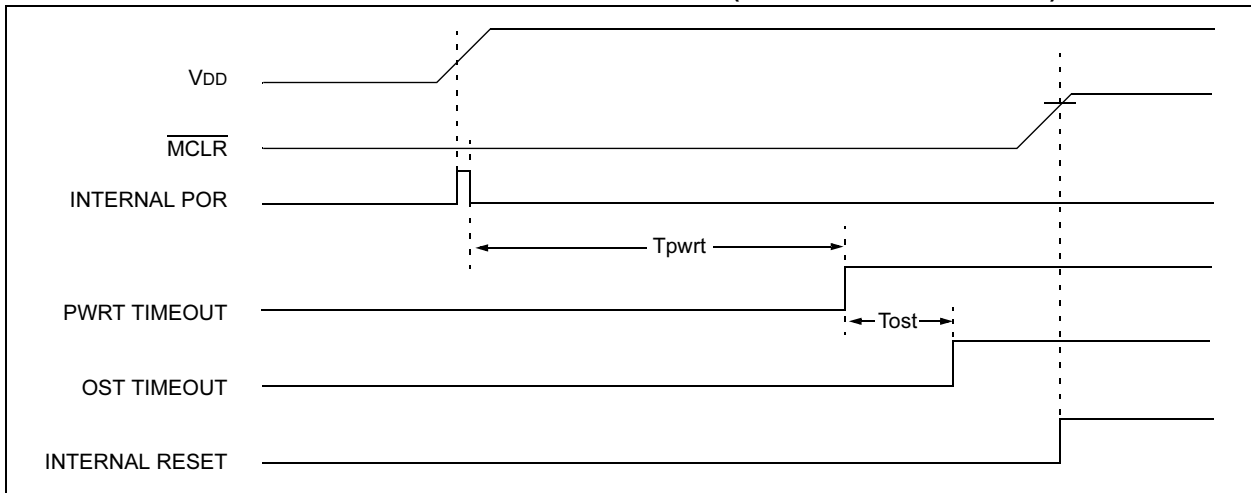
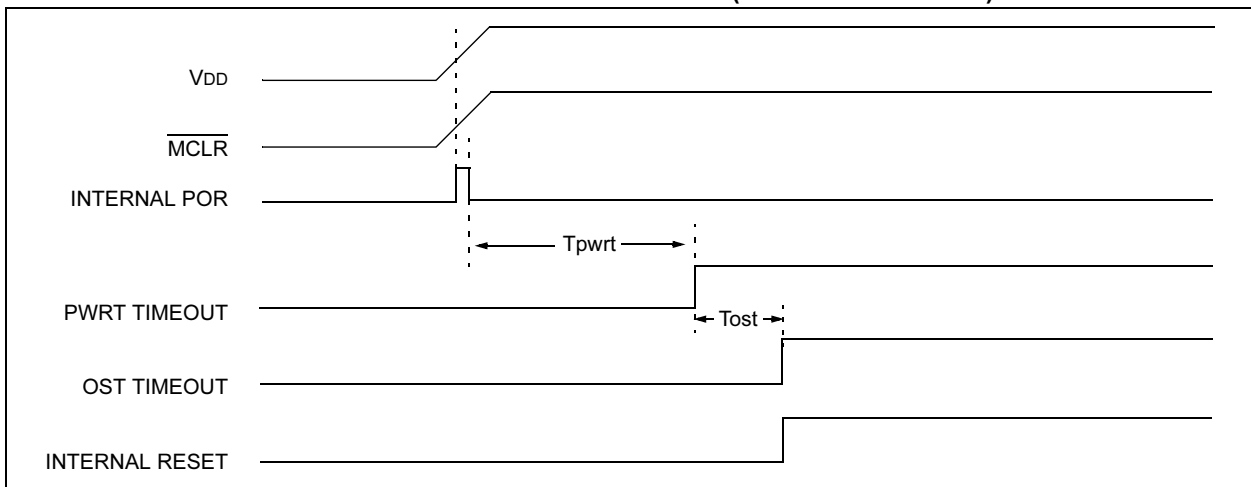

FIGURE 14-10: TIMEOUT SEQUENCE ON POWER-UP ($\overline{\text{MCLR}}$ TIED TO V_{DD})



PIC16F62X

FIGURE 14-11: EXTERNAL POWER-ON RESET CIRCUIT (FOR SLOW V_{DD} POWER-UP)

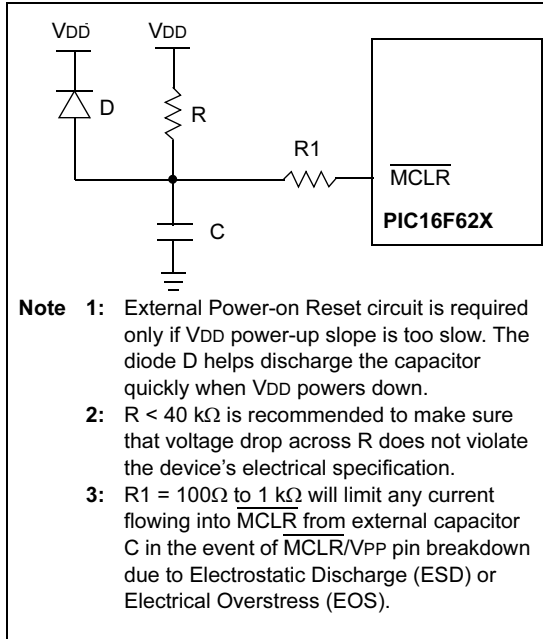

FIGURE 14-13: EXTERNAL BROWN-OUT PROTECTION CIRCUIT 2

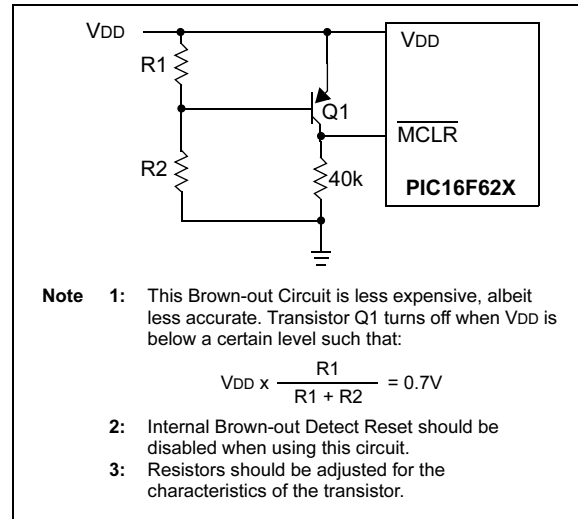
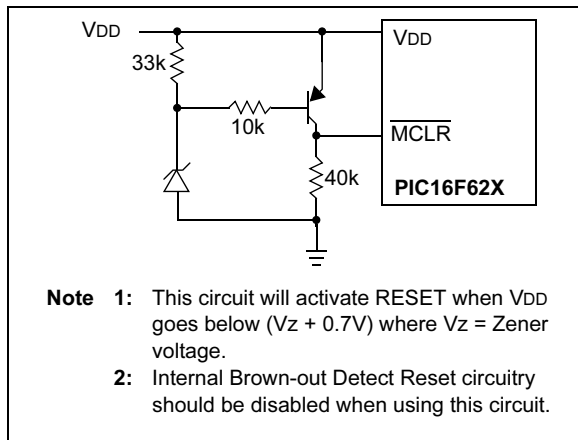

FIGURE 14-12: EXTERNAL BROWN-OUT PROTECTION CIRCUIT 1



14.6 Interrupts

The PIC16F62X has 10 sources of interrupt:

- External Interrupt RB0/INT
- TMR0 Overflow Interrupt
- PORTB Change Interrupts (pins RB7:RB4)
- Comparator Interrupt
- USART Interrupt TX
- USART Interrupt RX
- CCP Interrupt
- TMR1 Overflow Interrupt
- TMR2 Match Interrupt
- EEPROM

The interrupt control register (INTCON) records individual interrupt requests in flag bits. It also has individual and global interrupt enable bits.

A global interrupt enable bit, GIE (INTCON<7>) enables (if set) all un-masked interrupts or disables (if cleared) all interrupts. Individual interrupts can be disabled through their corresponding enable bits in INTCON register. GIE is cleared on RESET.

The “return from interrupt” instruction, RETFIE, exits interrupt routine as well as sets the GIE bit, which re-enables RB0/INT interrupts.

The INT pin interrupt, the RB port change interrupt and the TMR0 overflow interrupt flags are contained in the INTCON register.

The peripheral interrupt flag is contained in the special register PIR1. The corresponding interrupt enable bit is contained in special registers PIE1.

When an interrupt is responded to, the GIE is cleared to disable any further interrupt, the return address is pushed into the stack and the PC is loaded with 0004h. Once in the interrupt service routine the source(s) of the interrupt can be determined by polling the interrupt flag bits. The interrupt flag bit(s) must be cleared in software before re-enabling interrupts to avoid RB0/INT recursive interrupts.

For external interrupt events, such as the INT pin or PORTB change interrupt, the interrupt latency will be three or four instruction cycles. The exact latency depends when the interrupt event occurs (Figure 14-15). The latency is the same for one or two cycle instructions. Once in the interrupt service routine the source(s) of the interrupt can be determined by polling the interrupt flag bits. The interrupt flag bit(s) must be cleared in software before re-enabling interrupts to avoid multiple interrupt requests. Individual interrupt flag bits are set regardless of the status of their corresponding mask bit or the GIE bit.

Note 1: Individual interrupt flag bits are set regardless of the status of their corresponding mask bit or the GIE bit.

2: When an instruction that clears the GIE bit is executed, any interrupts that were pending for execution in the next cycle are ignored. The CPU will execute a NOP in the cycle immediately following the instruction which clears the GIE bit. The interrupts which were ignored are still pending to be serviced when the GIE bit is set again.

FIGURE 14-14: INTERRUPT LOGIC

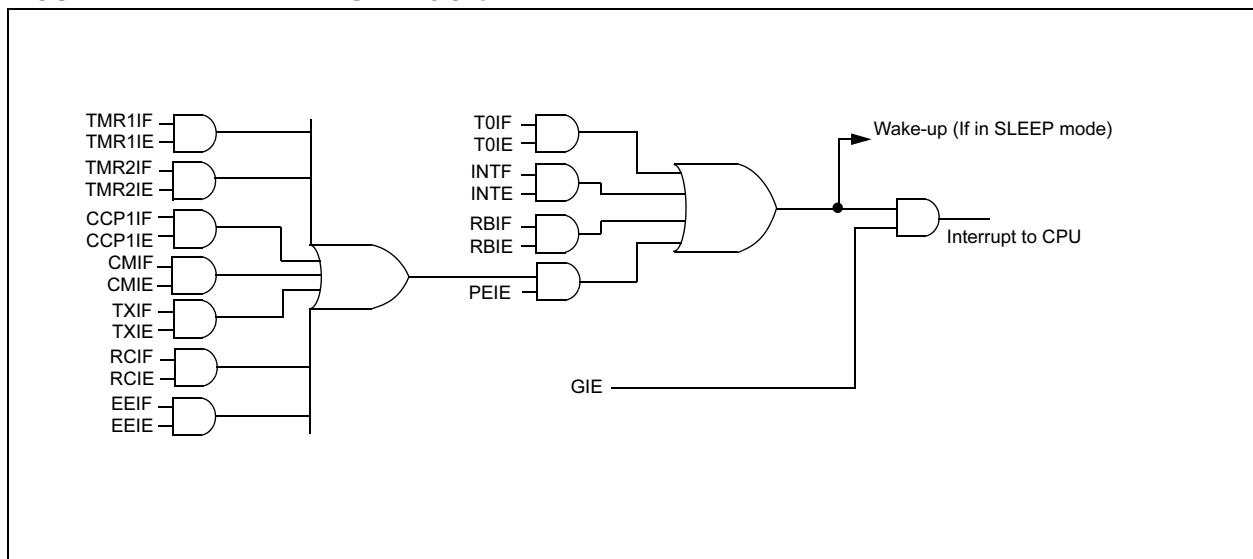

PIC16F62X

14.6.1 RB0/INT INTERRUPT

External interrupt on RB0/INT pin is edge triggered: either rising if INTEDG bit (OPTION<6>) is set, or falling, if INTEDG bit is clear. When a valid edge appears on the RB0/INT pin, the INTF bit (INTCON<1>) is set. This interrupt can be disabled by clearing the INTE control bit (INTCON<4>). The INTF bit must be cleared in software in the interrupt service routine before re-enabling this interrupt. The RB0/INT interrupt can wake-up the processor from SLEEP, if the INTE bit was set prior to going into SLEEP. The status of the GIE bit decides whether or not the processor branches to the interrupt vector following wake-up. See Section 14.9 for details on SLEEP, and Figure 14-17 for timing of wake-up from SLEEP through RB0/INT interrupt.

14.6.2 TMR0 INTERRUPT

An overflow (FFh → 00h) in the TMR0 register will set the T0IF (INTCON<2>) bit. The interrupt can be enabled/disabled by setting/clearing T0IE (INTCON<5>) bit. For operation of the Timer0 module, see Section 6.0.

14.6.3 PORTB INTERRUPT

An input change on PORTB <7:4> sets the RBIF (INTCON<0>) bit. The interrupt can be enabled/disabled by setting/clearing the RBIE (INTCON<4>) bit. For operation of PORTB (Section 5.2).

Note: If a change on the I/O pin should occur when the read operation is being executed (start of the Q2 cycle), then the RBIF interrupt flag may not get set.

14.6.4 COMPARATOR INTERRUPT

See Section 9.6 for complete description of comparator interrupts.

FIGURE 14-15: INT PIN INTERRUPT TIMING

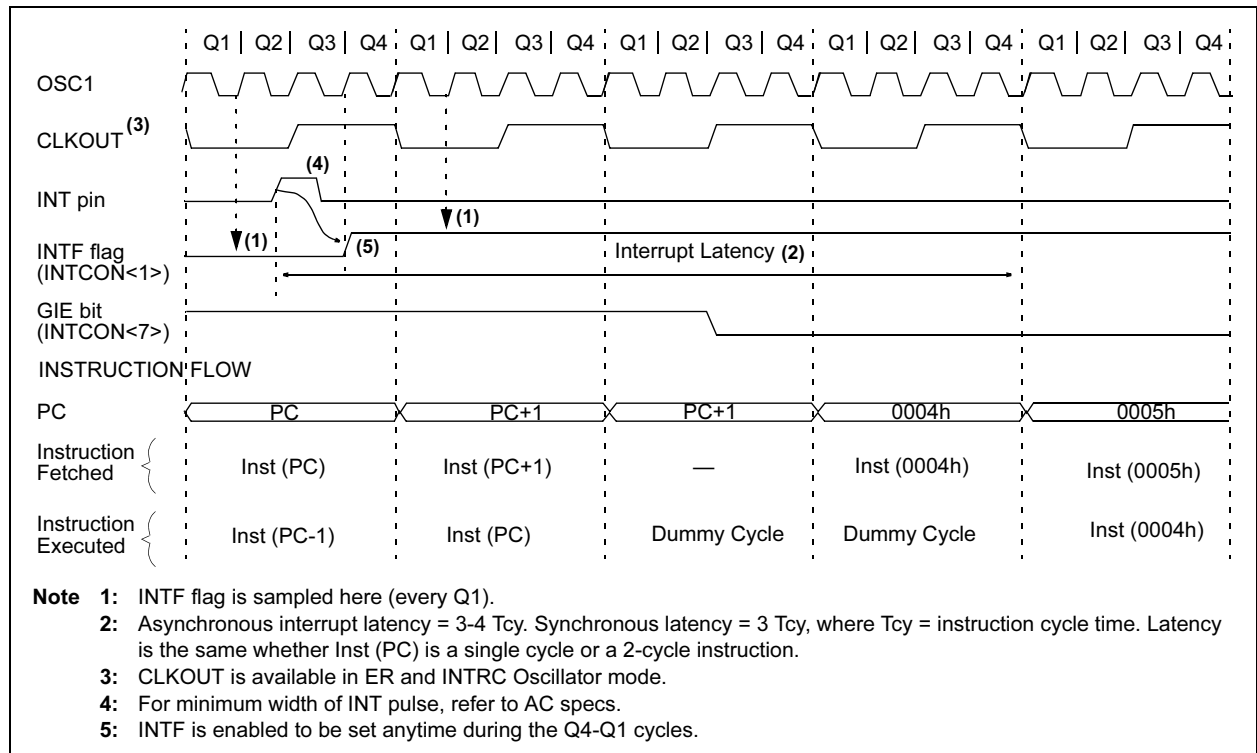

TABLE 14-9: SUMMARY OF INTERRUPT REGISTERS

Address	Name	Bit 7	Bit 6	Bit 5	Bit 4	Bit 3	Bit 2	Bit 1	Bit 0	Value on POR Reset	Value on all other RESETS ⁽¹⁾
0Bh	INTCON	GIE	PEIE	TOIE	INTE	RBIE	TOIF	INTF	RBIF	0000 000x	0000 000u
0Ch	PIR1	EEIF	CMIF	RCIF	TXIF	—	CCP1IF	TMR2IF	TMR1IF	0000 -000	0000 -000
8Ch	PIE1	EEIE	CMIE	RCIE	TXIE	—	CCP1IE	TMR2IE	TMR1IE	0000 -000	0000 -000

Note 1: Other (non Power-up) Resets include MCLR Reset, Brown-out Detect Reset and Watchdog Timer Reset during normal operation.

14.7 Context Saving During Interrupts

During an interrupt, only the return PC value is saved on the stack. Typically, users may wish to save key registers during an interrupt (e.g., W register and STATUS register). This will have to be implemented in software.

Example 14-2 stores and restores the STATUS and W registers. The user register, W_TEMP, must be defined in a common memory location (i.e., W_TEMP is defined at 0x70 in Bank 0 and is therefore, accessible at 0xF0, 0x17 and 0xFD). The Example 14-2:

- Stores the W register
- Stores the STATUS register
- Executes the ISR code
- Restores the STATUS (and bank select bit register)
- Restores the W register

EXAMPLE 14-2: SAVING THE STATUS AND W REGISTERS IN RAM

```

MOVWF  W_TEMP      ;copy W to temp register,
                   ;could be in either bank
SWAPF  STATUS,W    ;swap status to be saved
                   ;into W
BCF    STATUS,RP0  ;change to bank 0 regardless
                   ;of current bank
MOVWF  STATUS_TEMP ;save status to bank 0
                   ;register
:
: (ISR)
:
SWAPF  STATUS_TEMP,W ;swap STATUS_TEMP register
                   ;into W, sets bank to origi-
                   ;nal
                   ;state
MOVWF  STATUS      ;move W into STATUS register
SWAPF  W_TEMP,F    ;swap W_TEMP
SWAPF  W_TEMP,W    ;swap W_TEMP into W
    
```

14.8 Watchdog Timer (WDT)

The Watchdog Timer is a free running on-chip RC oscillator which does not require any external components. This RC oscillator is separate from the ER oscillator of the CLKIN pin. That means that the WDT will run, even if the clock on the OSC1 and OSC2 pins of the device has been stopped, for example, by execution of a SLEEP instruction. During normal operation, a WDT timeout generates a device RESET. If the device is in SLEEP mode, a WDT timeout causes the device to wake-up and continue with normal operation. The WDT can be permanently disabled by programming the configuration bit WDTE as clear (Section 14.1).

14.8.1 WDT PERIOD

The WDT has a nominal timeout period of 18 ms (with no prescaler). The timeout periods vary with temperature, VDD and process variations from part to part (see DC specs). If longer timeout periods are desired, a postscaler with a division ratio of up to 1:128 can be assigned to the WDT under software control by writing to the OPTION register. Thus, timeout periods up to 2.3 seconds can be realized.

The CLRWDT and SLEEP instructions clear the WDT and the postscaler, if assigned to the WDT, and prevent it from timing out and generating a device RESET.

The \overline{TO} bit in the STATUS register will be cleared upon a Watchdog Timer timeout.

14.8.2 WDT PROGRAMMING CONSIDERATIONS

It should also be taken in account that under worst case conditions (VDD = Min., Temperature = Max., max. WDT prescaler), it may take several seconds before a WDT timeout occurs.

PIC16F62X

FIGURE 14-16: WATCHDOG TIMER BLOCK DIAGRAM

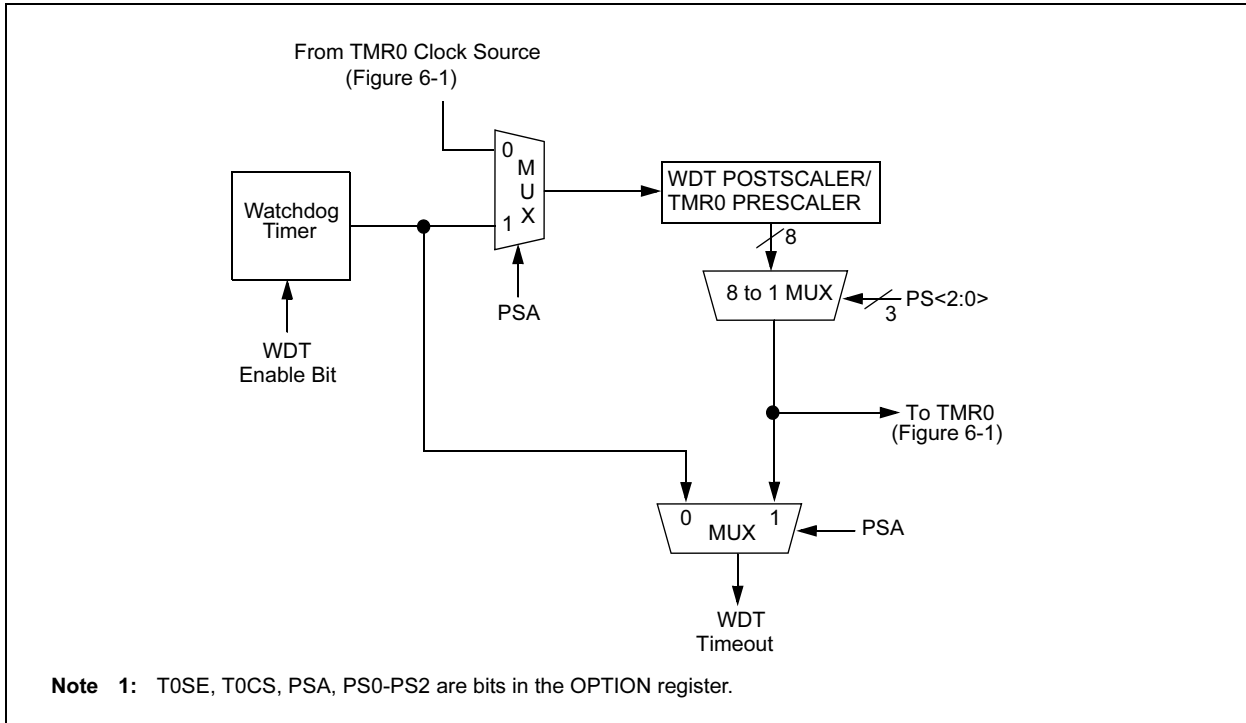

TABLE 14-10: SUMMARY OF WATCHDOG TIMER REGISTERS

Address	Name	Bit 7	Bit 6	Bit 5	Bit 4	Bit 3	Bit 2	Bit 1	Bit 0	Value on POR Reset	Value on all other RESETS
2007h	Config. bits	LVP	BODEN	MCLRE	FOSC2	PWRTE	WDTE	FOSC1	FOSC0	uuuu uuuu	uuuu uuuu
81h	OPTION	RBP <u>U</u>	INTEDG	T0CS	T0SE	PSA	PS2	PS1	PS0	1111 1111	1111 1111

Legend: – = Unimplemented location, read as “0”, + = Reserved for future use

Note 1: Shaded cells are not used by the Watchdog Timer.

14.9 Power-Down Mode (SLEEP)

The Power-down mode is entered by executing a SLEEP instruction.

If enabled, the Watchdog Timer will be cleared but keeps running, the PD bit in the STATUS register is cleared, the TO bit is set, and the oscillator driver is turned off. The I/O ports maintain the status they had, before SLEEP was executed (driving high, low, or hi-impedance).

For lowest current consumption in this mode, all I/O pins should be either at VDD, or VSS, with no external circuitry drawing current from the I/O pin and the comparators, and VREF should be disabled. I/O pins that are hi-impedance inputs should be pulled high or low externally to avoid switching currents caused by floating inputs. The T0CKI input should also be at VDD or VSS for lowest current consumption. The contribution from on-chip pull-ups on PORTB should be considered.

The MCLR pin must be at a logic high level (VIHMC).

Note: It should be noted that a RESET generated by a WDT timeout does not drive MCLR pin low.

14.9.1 WAKE-UP FROM SLEEP

The device can wake-up from SLEEP through one of the following events:

1. External RESET input on $\overline{\text{MCLR}}$ pin
2. Watchdog Timer Wake-up (if WDT was enabled)
3. Interrupt from RB0/INT pin, RB Port change, or the Peripheral Interrupt (Comparator).

The first event will cause a device RESET. The two latter events are considered a continuation of program execution. The $\overline{\text{TO}}$ and $\overline{\text{PD}}$ bits in the STATUS register can be used to determine the cause of device RESET. $\overline{\text{PD}}$ bit, which is set on power-up is cleared when SLEEP is invoked. $\overline{\text{TO}}$ bit is cleared if WDT Wake-up occurred.

When the SLEEP instruction is being executed, the next instruction (PC + 1) is pre-fetched. For the device to wake-up through an interrupt event, the

corresponding interrupt enable bit must be set (enabled). Wake-up is regardless of the state of the GIE bit. If the GIE bit is clear (disabled), the device continues execution at the instruction after the SLEEP instruction. If the GIE bit is set (enabled), the device executes the instruction after the SLEEP instruction and then branches to the interrupt address (0004h). In cases where the execution of the instruction following SLEEP is not desirable, the user should have an NOP after the SLEEP instruction.

Note: If the global interrupts are disabled (GIE is cleared), but any interrupt source has both its interrupt enable bit and the corresponding interrupt flag bits set, the device will immediately wake-up from SLEEP. The SLEEP instruction is completely executed.

The WDT is cleared when the device wakes-up from SLEEP, regardless of the source of wake-up.

FIGURE 14-17: WAKE-UP FROM SLEEP THROUGH INTERRUPT

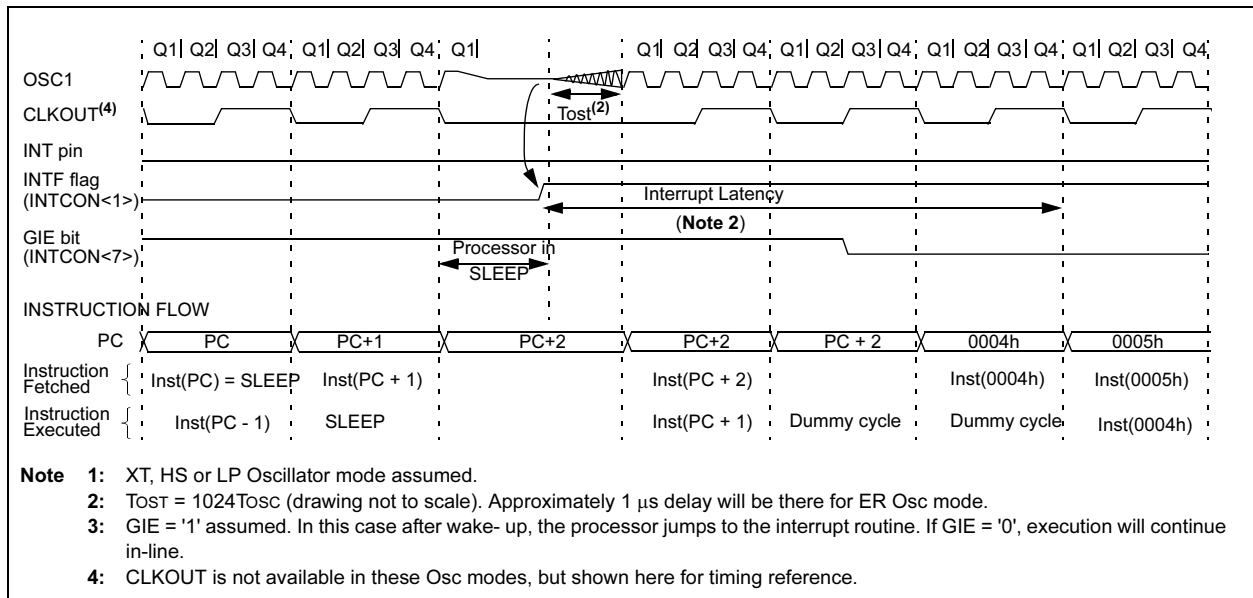

14.10 Code Protection

If the code protection bit(s) have not been programmed, the on-chip program memory can be read out for verification purposes.

Note: The entire data EEPROM and FLASH program memory will be erased when the code protection is turned off. The INTRC calibration data is not erased.

14.11 User ID Locations

Four memory locations (2000h-2003h) are designated as user ID locations where the user can store checksum or other code-identification numbers. These locations are not accessible during normal execution but are readable and writable during program/verify. Only the Least Significant 4 bits of the user ID locations are used.

PIC16F62X

14.12 In-Circuit Serial Programming

The PIC16F62X microcontrollers can be serially programmed while in the end application circuit. This is simply done with two lines for clock and data, and three other lines for power, ground, and the programming voltage. This allows customers to manufacture boards with unprogrammed devices, and then program the microcontroller just before shipping the product. This also allows the most recent firmware, or a custom firmware to be programmed.

The device is placed into a Program/Verify mode by holding the RB6 and RB7 pins low while raising the MCLR (VPP) pin from VIL to VIH (see programming specification). RB6 becomes the programming clock and RB7 becomes the programming data. Both RB6 and RB7 are Schmitt Trigger inputs in this mode.

After RESET, to place the device into Programming/Verify mode, the program counter (PC) is at location 00h. A 6-bit command is then supplied to the device. Depending on the command, 14 bits of program data are then supplied to or from the device, depending if the command was a load or a read. For complete details of serial programming, please refer to the Programming Specifications.

A typical in-circuit serial programming connection is shown in Figure 14-18.

FIGURE 14-18: TYPICAL IN-CIRCUIT SERIAL PROGRAMMING CONNECTION

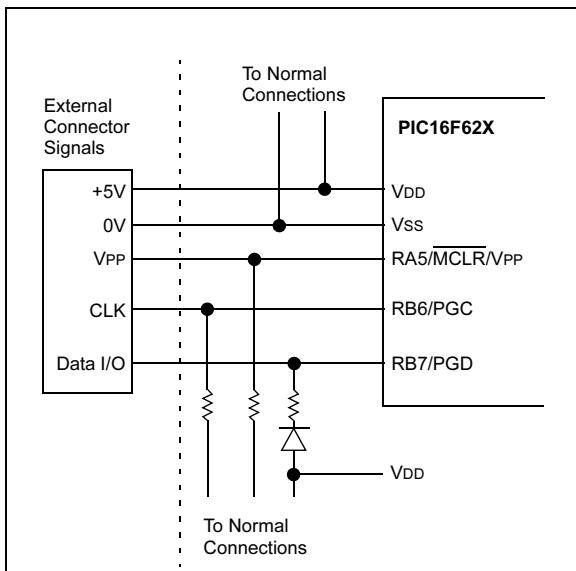

14.13 Low Voltage Programming

The LVP bit of the configuration word, enables the low voltage programming. This mode allows the microcontroller to be programmed via ICSP using only a 5V source. This mode removes the requirement of VIH on the MCLR pin. The LVP bit is normally erased to '1', which enables the low voltage programming. In this mode, the RB4/PGM pin is dedicated to the programming function and ceases to be a general purpose I/O pin. The device will enter Programming mode when a '1' is placed on the RB4/PGM pin. The HV Programming mode is still available by placing VIH on the MCLR pin.

Note 1: While in this mode, the RB4 pin can no longer be used as a general purpose I/O pin.

2: VDD must be 5.0V \pm 10% during erase/program operations while in low voltage Programming mode.

If Low voltage Programming mode is not used, the LVP bit can be programmed to a '0', and RB4/PGM becomes a digital I/O pin. To program the device, VIH must be placed onto MCLR during programming. The LVP bit may only be programmed when programming is entered with VIH on MCLR. The LVP bit cannot be programmed when programming is entered with RB4/PGM.

It should be noted, that once the LVP bit is programmed to 0, High voltage Programming mode can be used to program the device.

15.0 INSTRUCTION SET SUMMARY

Each PIC16F62X instruction is a 14-bit word divided into an OPCODE which specifies the instruction type and one or more operands which further specify the operation of the instruction. The PIC16F62X instruction set summary in Table 15-2 lists byte-oriented, bit-oriented, and literal and control operations. Table 15-1 shows the opcode field descriptions.

For byte-oriented instructions, 'f' represents a file register designator and 'd' represents a destination designator. The file register designator specifies which file register is to be used by the instruction.

The destination designator specifies where the result of the operation is to be placed. If 'd' is zero, the result is placed in the W register. If 'd' is one, the result is placed in the file register specified in the instruction.

For bit-oriented instructions, 'b' represents a bit field designator which selects the number of the bit affected by the operation, while 'f' represents the number of the file in which the bit is located.

For literal and control operations, 'k' represents an eight or eleven bit constant or literal value.

TABLE 15-1: OPCODE FIELD DESCRIPTIONS

Field	Description
f	Register file address (0x00 to 0x7F)
W	Working register (accumulator)
b	Bit address within an 8-bit file register
k	Literal field, constant data or label
x	Don't care location (= 0 or 1) The assembler will generate code with x = 0. It is the recommended form of use for compatibility with all Microchip software tools.
d	Destination select; d = 0: store result in W, d = 1: store result in file register f. Default is d = 1
label	Label name
TOS	Top of Stack
PC	Program Counter
PCLA TH	Program Counter High Latch
GIE	Global Interrupt Enable bit
WDT	Watchdog Timer/Counter
TO	Timeout bit
PD	Power-down bit
dest	Destination either the W register or the specified register file location
[]	Options
()	Contents
→	Assigned to
< >	Register bit field
∈	In the set of
<i>italics</i>	User defined term (font is courier)

The instruction set is highly orthogonal and is grouped into three basic categories:

- **Byte-oriented** operations
- **Bit-oriented** operations
- **Literal and control** operations

All instructions are executed within one single instruction cycle, unless a conditional test is true or the program counter is changed as a result of an instruction. In this case, the execution takes two instruction cycles with the second cycle executed as a NOP. One instruction cycle consists of four oscillator periods. Thus, for an oscillator frequency of 4 MHz, the normal instruction execution time is 1 μs. If a conditional test is true or the program counter is changed as a result of an instruction, the instruction execution time is 2 μs.

Table 15-2 lists the instructions recognized by the MPASM™ assembler.

Figure 15-1 shows the three general formats that the instructions can have.

Note 1: Any unused opcode is reserved. Use of any reserved opcode may cause unexpected operation.

2: To maintain upward compatibility with future PICmicro® products, do not use the OPTION and TRIS instructions.

All examples use the following format to represent a hexadecimal number:

0xhh

where h signifies a hexadecimal digit.

FIGURE 15-1: GENERAL FORMAT FOR INSTRUCTIONS

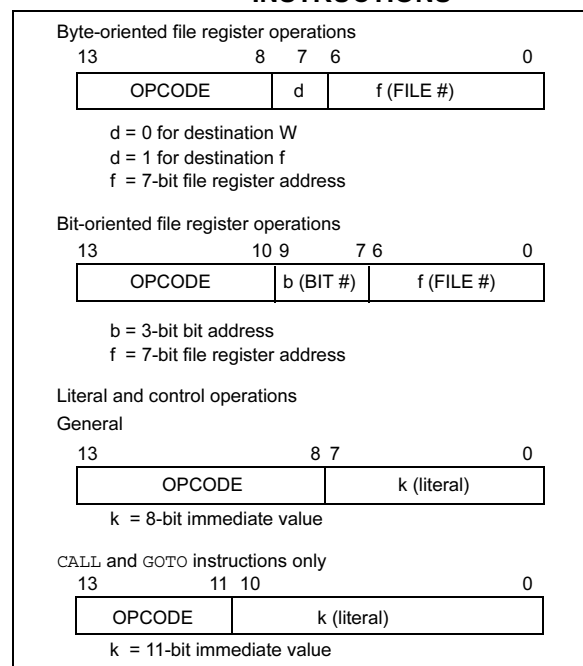

PIC16F62X

TABLE 15-2: PIC16F62X INSTRUCTION SET

Mnemonic, Operands	Description	Cycles	14-Bit Opcode				Status Affected	Notes	
			MSb	LSb					
BYTE-ORIENTED FILE REGISTER OPERATIONS									
ADDWF	f, d	Add W and f	1	00	0111	dfff	ffff	C,DC,Z	1,2
ANDWF	f, d	AND W with f	1	00	0101	dfff	ffff	Z	1,2
CLRF	f	Clear f	1	00	0001	1fff	ffff	Z	2
CLRWF	—	Clear W	1	00	0001	0000	0011	Z	
COMF	f, d	Complement f	1	00	1001	dfff	ffff	Z	1,2
DECF	f, d	Decrement f	1	00	0011	dfff	ffff	Z	1,2
DECFSZ	f, d	Decrement f, Skip if 0	1(2)	00	1011	dfff	ffff		1,2,3
INCF	f, d	Increment f	1	00	1010	dfff	ffff	Z	1,2
INCFSZ	f, d	Increment f, Skip if 0	1(2)	00	1111	dfff	ffff		1,2,3
IORWF	f, d	Inclusive OR W with f	1	00	0100	dfff	ffff	Z	1,2
MOVF	f, d	Move f	1	00	1000	dfff	ffff	Z	1,2
MOVWF	f	Move W to f	1	00	0000	1fff	ffff		
NOP	—	No Operation	1	00	0000	0xx0	0000		
RLF	f, d	Rotate Left f through Carry	1	00	1101	dfff	ffff	C	1,2
RRF	f, d	Rotate Right f through Carry	1	00	1100	dfff	ffff	C	1,2
SUBWF	f, d	Subtract W from f	1	00	0010	dfff	ffff	C,DC,Z	1,2
SWAPF	f, d	Swap nibbles in f	1	00	1110	dfff	ffff		1,2
XORWF	f, d	Exclusive OR W with f	1	00	0110	dfff	ffff	Z	1,2
BIT-ORIENTED FILE REGISTER OPERATIONS									
BCF	f, b	Bit Clear f	1	01	00bb	bfff	ffff		1,2
BSF	f, b	Bit Set f	1	01	01bb	bfff	ffff		1,2
BTFSC	f, b	Bit Test f, Skip if Clear	1(2)	01	10bb	bfff	ffff		3
BTFSS	f, b	Bit Test f, Skip if Set	1(2)	01	11bb	bfff	ffff		3
LITERAL AND CONTROL OPERATIONS									
ADDLW	k	Add literal and W	1	11	111x	kkkk	kkkk	C,DC,Z	
ANDLW	k	AND literal with W	1	11	1001	kkkk	kkkk	Z	
CALL	k	Call subroutine	2	10	0kkk	kkkk	kkkk		
CLRWDT	—	Clear Watchdog Timer	1	00	0000	0110	0100	$\overline{TO}, \overline{PD}$	
GOTO	k	Go to address	2	10	1kkk	kkkk	kkkk		
IORLW	k	Inclusive OR literal with W	1	11	1000	kkkk	kkkk	Z	
MOVLW	k	Move literal to W	1	11	00xx	kkkk	kkkk		
RETFIE	—	Return from interrupt	2	00	0000	0000	1001		
RETLW	k	Return with literal in W	2	11	01xx	kkkk	kkkk		
RETURN	—	Return from Subroutine	2	00	0000	0000	1000		
SLEEP	—	Go into Standby mode	1	00	0000	0110	0011	$\overline{TO}, \overline{PD}$	
SUBLW	k	Subtract W from literal	1	11	110x	kkkk	kkkk	C,DC,Z	
XORLW	k	Exclusive OR literal with W	1	11	1010	kkkk	kkkk	Z	

- Note** 1: When an I/O register is modified as a function of itself (e.g., MOVF PORTB, 1), the value used will be that value present on the pins themselves. For example, if the data latch is '1' for a pin configured as input and is driven low by an external device, the data will be written back with a '0'.
- 2: If this instruction is executed on the TMR0 register (and, where applicable, d = 1), the prescaler will be cleared if assigned to the Timer0 Module.
- 3: If Program Counter (PC) is modified or a conditional test is true, the instruction requires two cycles. The second cycle is executed as a NOP.

15.1 Instruction Descriptions

ADDLW Add Literal and W

Syntax:	[<i>label</i>] ADDLW <i>k</i>				
Operands:	$0 \leq k \leq 255$				
Operation:	$(W) + k \rightarrow (W)$				
Status Affected:	C, DC, Z				
Encoding:	<table border="1" style="display: inline-table; border-collapse: collapse;"> <tr> <td style="padding: 2px;">11</td> <td style="padding: 2px;">111x</td> <td style="padding: 2px;">kkkk</td> <td style="padding: 2px;">kkkk</td> </tr> </table>	11	111x	kkkk	kkkk
11	111x	kkkk	kkkk		
Description:	The contents of the W register are added to the eight bit literal 'k' and the result is placed in the W register.				
Words:	1				
Cycles:	1				
Example	ADDLW 0x15 Before Instruction W = 0x10 After Instruction W = 0x25				

ADDWF Add W and f

Syntax:	[<i>label</i>] ADDWF <i>f</i> , <i>d</i>				
Operands:	$0 \leq f \leq 127$ $d \in [0,1]$				
Operation:	$(W) + (f) \rightarrow (\text{dest})$				
Status Affected:	C, DC, Z				
Encoding:	<table border="1" style="display: inline-table; border-collapse: collapse;"> <tr> <td style="padding: 2px;">00</td> <td style="padding: 2px;">0111</td> <td style="padding: 2px;">dfff</td> <td style="padding: 2px;">ffff</td> </tr> </table>	00	0111	dfff	ffff
00	0111	dfff	ffff		
Description:	Add the contents of the W register with register 'f'. If 'd' is 0 the result is stored in the W register. If 'd' is 1 the result is stored back in register 'f'.				
Words:	1				
Cycles:	1				
Example	ADDWF REG1, 0 Before Instruction W = 0x17 REG1 = 0xC2 After Instruction W = 0xD9 REG1 = 0xC2 Z = 0 C = 0 DC = 0				

ANDLW AND Literal with W

Syntax:	[<i>label</i>] ANDLW <i>k</i>				
Operands:	$0 \leq k \leq 255$				
Operation:	$(W) .\text{AND.} (k) \rightarrow (W)$				
Status Affected:	Z				
Encoding:	<table border="1" style="display: inline-table; border-collapse: collapse;"> <tr> <td style="padding: 2px;">11</td> <td style="padding: 2px;">1001</td> <td style="padding: 2px;">kkkk</td> <td style="padding: 2px;">kkkk</td> </tr> </table>	11	1001	kkkk	kkkk
11	1001	kkkk	kkkk		
Description:	The contents of W register are AND'ed with the eight bit literal 'k'. The result is placed in the W register.				
Words:	1				
Cycles:	1				
Example	ANDLW 0x5F Before Instruction W = 0xA3 After Instruction W = 0x03				

ANDWF AND W with f

Syntax:	[<i>label</i>] ANDWF <i>f</i> , <i>d</i>				
Operands:	$0 \leq f \leq 127$ $d \in [0,1]$				
Operation:	$(W) .\text{AND.} (f) \rightarrow (\text{dest})$				
Status Affected:	Z				
Encoding:	<table border="1" style="display: inline-table; border-collapse: collapse;"> <tr> <td style="padding: 2px;">00</td> <td style="padding: 2px;">0101</td> <td style="padding: 2px;">dfff</td> <td style="padding: 2px;">ffff</td> </tr> </table>	00	0101	dfff	ffff
00	0101	dfff	ffff		
Description:	AND the W register with register 'f'. If 'd' is 0 the result is stored in the W register. If 'd' is 1 the result is stored back in register 'f'.				
Words:	1				
Cycles:	1				
Example	ANDWF REG1, 1 Before Instruction W = 0x17 REG1 = 0xC2 After Instruction W = 0x17 REG1 = 0x02				

PIC16F62X

BCF Bit Clear f

Syntax: `[label] BCF f,b`

Operands: $0 \leq f \leq 127$
 $0 \leq b \leq 7$

Operation: $0 \rightarrow (f)$

Status Affected: None

Encoding:

01	00bb	bfff	ffff
----	------	------	------

Description: Bit 'b' in register 'f' is cleared.

Words: 1

Cycles: 1

Example `BCF REG1, 7`

Before Instruction
`REG1 = 0xC7`

After Instruction
`REG1 = 0x47`

BSF Bit Set f

Syntax: `[label] BSF f,b`

Operands: $0 \leq f \leq 127$
 $0 \leq b \leq 7$

Operation: $1 \rightarrow (f)$

Status Affected: None

Encoding:

01	01bb	bfff	ffff
----	------	------	------

Description: Bit 'b' in register 'f' is set.

Words: 1

Cycles: 1

Example `BSF REG1, 7`

Before Instruction
`REG1 = 0x0A`

After Instruction
`REG1 = 0x8A`

BTFSC Bit Test f, Skip if Clear

Syntax: `[label] BTFSC f,b`

Operands: $0 \leq f \leq 127$
 $0 \leq b \leq 7$

Operation: skip if $(f) = 0$

Status Affected: None

Encoding:

01	10bb	bfff	ffff
----	------	------	------

Description: If bit 'b' in register 'f' is '0' then the next instruction is skipped. If bit 'b' is '0' then the next instruction fetched during the current instruction execution is discarded, and a NOP is executed instead, making this a two-cycle instruction.

Words: 1

Cycles: 1(2)

Example

```

HERE    BTFSC    REG1
FALSE   GOTO    PROCESS_CODE
TRUE    •
        •
        •

```

Before Instruction
`PC = address HERE`

After Instruction
if `REG<1> = 0,`
`PC = address TRUE`
if `REG<1>=1,`
`PC = address FALSE`

BTFSS Bit Test f, Skip if Set

Syntax: `[label] BTFSS f,b`

Operands: $0 \leq f \leq 127$
 $0 \leq b < 7$

Operation: skip if $(f \ll b) = 1$

Status Affected: None

Encoding:

01	11bb	bfff	ffff
----	------	------	------

Description: If bit 'b' in register 'f' is '1' then the next instruction is skipped. If bit 'b' is '1', then the next instruction fetched during the current instruction execution, is discarded and a NOP is executed instead, making this a two-cycle instruction.

Words: 1

Cycles: 1(2)

Example

```

HERE   BTFSS   REG1
FALSE  GOTO   PROCESS_CODE
TRUE   •
       •
       •

Before Instruction
PC = address HERE
After Instruction
if FLAG<1> = 0,
PC = address FALSE
if FLAG<1> = 1,
PC = address TRUE
    
```

CALL Call Subroutine

Syntax: `[label] CALL k`

Operands: $0 \leq k \leq 2047$

Operation: $(PC)+1 \rightarrow TOS$,
 $k \rightarrow PC \langle 10:0 \rangle$,
 $(PCLATH \langle 4:3 \rangle) \rightarrow PC \langle 12:11 \rangle$

Status Affected: None

Encoding:

10	0kkk	kkkk	kkkk
----	------	------	------

Description: Call Subroutine. First, return address $(PC+1)$ is pushed onto the stack. The eleven bit immediate address is loaded into PC bits $\langle 10:0 \rangle$. The upper bits of the PC are loaded from PCLATH. CALL is a two-cycle instruction.

Words: 1

Cycles: 2

Example

```

HERE   CALL   THERE

Before Instruction
PC = Address HERE
After Instruction
PC = Address THERE
TOS = Address HERE+1
    
```

CLRF Clear f

Syntax: `[label] CLRF f`

Operands: $0 \leq f \leq 127$

Operation: $00h \rightarrow (f)$
 $1 \rightarrow Z$

Status Affected: Z

Encoding:

00	0001	1fff	ffff
----	------	------	------

Description: The contents of register 'f' are cleared and the Z bit is set.

Words: 1

Cycles: 1

Example

```

CLRF   REG1

Before Instruction
REG1 = 0x5A
After Instruction
REG1 = 0x00
Z     = 1
    
```

PIC16F62X

CLR W Clear W

Syntax:	[<i>label</i>] CLRW				
Operands:	None				
Operation:	00h → (W) 1 → Z				
Status Affected:	Z				
Encoding:	<table border="1" style="display: inline-table; border-collapse: collapse;"><tr><td style="padding: 2px;">00</td><td style="padding: 2px;">0001</td><td style="padding: 2px;">0000</td><td style="padding: 2px;">0011</td></tr></table>	00	0001	0000	0011
00	0001	0000	0011		
Description:	W register is cleared. Zero bit (Z) is set.				
Words:	1				
Cycles:	1				
Example	<pre>CLRW Before Instruction W = 0x5A After Instruction W = 0x00 Z = 1</pre>				

COMF Complement f

Syntax:	[<i>label</i>] COMF f,d				
Operands:	0 ≤ f ≤ 127 d ∈ [0,1]				
Operation:	(f) → (dest)				
Status Affected:	Z				
Encoding:	<table border="1" style="display: inline-table; border-collapse: collapse;"><tr><td style="padding: 2px;">00</td><td style="padding: 2px;">1001</td><td style="padding: 2px;">dfff</td><td style="padding: 2px;">ffff</td></tr></table>	00	1001	dfff	ffff
00	1001	dfff	ffff		
Description:	The contents of register 'f' are complemented. If 'd' is 0 the result is stored in W. If 'd' is 1 the result is stored back in register 'f'.				
Words:	1				
Cycles:	1				
Example	<pre>COMF REG1, 0 Before Instruction REG1 = 0x13 After Instruction REG1 = 0x13 W = 0xEC</pre>				

CLRWD T Clear Watchdog Timer

Syntax:	[<i>label</i>] CLRWD T				
Operands:	None				
Operation:	00h → WDT 0 → WDT prescaler, 1 → \overline{TO} 1 → \overline{PD}				
Status Affected:	\overline{TO} , \overline{PD}				
Encoding:	<table border="1" style="display: inline-table; border-collapse: collapse;"><tr><td style="padding: 2px;">00</td><td style="padding: 2px;">0000</td><td style="padding: 2px;">0110</td><td style="padding: 2px;">0100</td></tr></table>	00	0000	0110	0100
00	0000	0110	0100		
Description:	CLRWD T instruction resets the Watchdog Timer. It also resets the prescaler of the WDT. STATUS bits \overline{TO} and \overline{PD} are set.				
Words:	1				
Cycles:	1				
Example	<pre>CLRWD T Before Instruction WDT counter = ? After Instruction WDT counter = 0x00 WDT prescaler = 0 \overline{TO} = 1 \overline{PD} = 1</pre>				

DECF Decrement f

Syntax:	[<i>label</i>] DECF f,d				
Operands:	0 ≤ f ≤ 127 d ∈ [0,1]				
Operation:	(f) - 1 → (dest)				
Status Affected:	Z				
Encoding:	<table border="1" style="display: inline-table; border-collapse: collapse;"><tr><td style="padding: 2px;">00</td><td style="padding: 2px;">0011</td><td style="padding: 2px;">dfff</td><td style="padding: 2px;">ffff</td></tr></table>	00	0011	dfff	ffff
00	0011	dfff	ffff		
Description:	Decrement register 'f'. If 'd' is 0 the result is stored in the W register. If 'd' is 1 the result is stored back in register 'f'.				
Words:	1				
Cycles:	1				
Example	<pre>DECF CNT, 1 Before Instruction CNT = 0x01 Z = 0 After Instruction CNT = 0x00 Z = 1</pre>				

DECFSZ	Decrement f, Skip if 0				
Syntax:	[<i>label</i>] DECFSZ f,d				
Operands:	0 ≤ f ≤ 127 d ∈ [0,1]				
Operation:	(f) - 1 → (dest); skip if result = 0				
Status Affected:	None				
Encoding:	<table border="1" style="display: inline-table; border-collapse: collapse;"> <tr> <td style="padding: 2px 10px;">00</td> <td style="padding: 2px 10px;">1011</td> <td style="padding: 2px 10px;">dfff</td> <td style="padding: 2px 10px;">ffff</td> </tr> </table>	00	1011	dfff	ffff
00	1011	dfff	ffff		
Description:	<p>The contents of register 'f' are decremented. If 'd' is 0 the result is placed in the W register. If 'd' is 1 the result is placed back in register 'f'.</p> <p>If the result is 0, the next instruction, which is already fetched, is discarded. A NOP is executed instead making it a two-cycle instruction.</p>				
Words:	1				
Cycles:	1(2)				
Example	<pre> HERE DECFSZ REG1, 1 GOTO LOOP CONTINUE • • • </pre> <p>Before Instruction PC = address HERE</p> <p>After Instruction REG1 = REG1 - 1 if REG1 = 0, PC = address CONTINUE if REG1 ≠ 0, PC = address HERE+1 </p>				

GOTO	Unconditional Branch				
Syntax:	[<i>label</i>] GOTO k				
Operands:	0 ≤ k ≤ 2047				
Operation:	k → PC<10:0> PCLATH<4:3> → PC<12:11>				
Status Affected:	None				
Encoding:	<table border="1" style="display: inline-table; border-collapse: collapse;"> <tr> <td style="padding: 2px 10px;">10</td> <td style="padding: 2px 10px;">1kkk</td> <td style="padding: 2px 10px;">kkkk</td> <td style="padding: 2px 10px;">kkkk</td> </tr> </table>	10	1kkk	kkkk	kkkk
10	1kkk	kkkk	kkkk		
Description:	<p>GOTO is an unconditional branch. The eleven bit immediate value is loaded into PC bits <10:0>. The upper bits of PC are loaded from PCLATH<4:3>. GOTO is a two-cycle instruction.</p>				
Words:	1				
Cycles:	2				
Example	<pre> GOTO THERE </pre> <p>After Instruction PC = Address THERE</p>				

PIC16F62X

INCF Increment f

Syntax: `[label] INCF f,d`

Operands: $0 \leq f \leq 127$
 $d \in [0,1]$

Operation: $(f) + 1 \rightarrow (\text{dest})$

Status Affected: Z

Encoding:

00	1010	dfff	ffff
----	------	------	------

Description: The contents of register 'f' are incremented. If 'd' is 0 the result is placed in the W register. If 'd' is 1 the result is placed back in register 'f'.

Words: 1

Cycles: 1

Example `INCF REG1, 1`

Before Instruction
`REG1 = 0xFF`
`Z = 0`
 After Instruction
`REG1 = 0x00`
`Z = 1`

INCFSZ Increment f, Skip if 0

Syntax: `[label] INCFSZ f,d`

Operands: $0 \leq f \leq 127$
 $d \in [0,1]$

Operation: $(f) + 1 \rightarrow (\text{dest})$, skip if result = 0

Status Affected: None

Encoding:

00	1111	dfff	ffff
----	------	------	------

Description: The contents of register 'f' are incremented. If 'd' is 0 the result is placed in the W register. If 'd' is 1 the result is placed back in register 'f'.

If the result is 0, the next instruction, which is already fetched, is discarded. A NOP is executed instead making it a two-cycle instruction.

Words: 1

Cycles: 1(2)

Example `HERE INCFSZ REG1, 1`

`GOTO LOOP`

`CONTINUE`
 •
 •
 •

Before Instruction
`PC = address HERE`

After Instruction
`REG1 = REG1 + 1`
 if `CNT = 0`,
`PC = address CONTINUE`
 if `REG1 ≠ 0`,
`PC = address HERE + 1`

IORLW Inclusive OR Literal with W

Syntax:	[<i>label</i>] IORLW k				
Operands:	$0 \leq k \leq 255$				
Operation:	(W) .OR. k \rightarrow (W)				
Status Affected:	Z				
Encoding:	<table border="1" style="display: inline-table; border-collapse: collapse;"><tr><td style="padding: 2px 10px;">11</td><td style="padding: 2px 10px;">1000</td><td style="padding: 2px 10px;">kkkk</td><td style="padding: 2px 10px;">kkkk</td></tr></table>	11	1000	kkkk	kkkk
11	1000	kkkk	kkkk		
Description:	The contents of the W register is OR'ed with the eight bit literal 'k'. The result is placed in the W register.				
Words:	1				
Cycles:	1				
Example	IORLW 0x35 Before Instruction W = 0x9A After Instruction W = 0xBF Z = 0				

MOVLW Move Literal to W

Syntax:	[<i>label</i>] MOVLW k				
Operands:	$0 \leq k \leq 255$				
Operation:	k \rightarrow (W)				
Status Affected:	None				
Encoding:	<table border="1" style="display: inline-table; border-collapse: collapse;"><tr><td style="padding: 2px 10px;">11</td><td style="padding: 2px 10px;">00xx</td><td style="padding: 2px 10px;">kkkk</td><td style="padding: 2px 10px;">kkkk</td></tr></table>	11	00xx	kkkk	kkkk
11	00xx	kkkk	kkkk		
Description:	The eight bit literal 'k' is loaded into W register. The don't cares will assemble as 0's.				
Words:	1				
Cycles:	1				
Example	MOVLW 0x5A After Instruction W = 0x5A				

IORWF Inclusive OR W with f

Syntax:	[<i>label</i>] IORWF f,d				
Operands:	$0 \leq f \leq 127$ $d \in [0,1]$				
Operation:	(W) .OR. (f) \rightarrow (dest)				
Status Affected:	Z				
Encoding:	<table border="1" style="display: inline-table; border-collapse: collapse;"><tr><td style="padding: 2px 10px;">00</td><td style="padding: 2px 10px;">0100</td><td style="padding: 2px 10px;">dfff</td><td style="padding: 2px 10px;">ffff</td></tr></table>	00	0100	dfff	ffff
00	0100	dfff	ffff		
Description:	Inclusive OR the W register with register 'f'. If 'd' is 0 the result is placed in the W register. If 'd' is 1 the result is placed back in register 'f'.				
Words:	1				
Cycles:	1				
Example	IORWF REG1, 0 Before Instruction REG1 = 0x13 W = 0x91 After Instruction REG1 = 0x13 W = 0x93 Z = 1				

MOVF Move f

Syntax:	[<i>label</i>] MOVF f,d				
Operands:	$0 \leq f \leq 127$ $d \in [0,1]$				
Operation:	(f) \rightarrow (dest)				
Status Affected:	Z				
Encoding:	<table border="1" style="display: inline-table; border-collapse: collapse;"><tr><td style="padding: 2px 10px;">00</td><td style="padding: 2px 10px;">1000</td><td style="padding: 2px 10px;">dfff</td><td style="padding: 2px 10px;">ffff</td></tr></table>	00	1000	dfff	ffff
00	1000	dfff	ffff		
Description:	The contents of register f is moved to a destination dependent upon the status of d. If d = 0, destination is W register. If d = 1, the destination is file register f itself. d = 1 is useful to test a file register since status flag Z is affected.				
Words:	1				
Cycles:	1				
Example	MOVF REG1, 0 After Instruction W = value in REG1 register Z = 1				

PIC16F62X

MOVWF Move W to f

Syntax:	[<i>label</i>] MOVWF f				
Operands:	$0 \leq f \leq 127$				
Operation:	(W) → (f)				
Status Affected:	None				
Encoding:	<table border="1" style="display: inline-table; border-collapse: collapse;"> <tr> <td style="padding: 2px 10px;">00</td> <td style="padding: 2px 10px;">0000</td> <td style="padding: 2px 10px;">1fff</td> <td style="padding: 2px 10px;">ffff</td> </tr> </table>	00	0000	1fff	ffff
00	0000	1fff	ffff		
Description:	Move data from W register to register 'f'.				
Words:	1				
Cycles:	1				
Example	<pre>MOVWF REG1 Before Instruction REG1 = 0xFF W = 0x4F After Instruction REG1 = 0x4F W = 0x4F</pre>				

OPTION Load Option Register

Syntax:	[<i>label</i>] OPTION				
Operands:	None				
Operation:	(W) → OPTION				
Status Affected:	None				
Encoding:	<table border="1" style="display: inline-table; border-collapse: collapse;"> <tr> <td style="padding: 2px 10px;">00</td> <td style="padding: 2px 10px;">0000</td> <td style="padding: 2px 10px;">0110</td> <td style="padding: 2px 10px;">0010</td> </tr> </table>	00	0000	0110	0010
00	0000	0110	0010		
Description:	The contents of the W register are loaded in the OPTION register. This instruction is supported for code compatibility with PIC16C5X products. Since OPTION is a readable/writable register, the user can directly address it. Using only register instruction such as MOVWF.				
Words:	1				
Cycles:	1				
Example					

To maintain upward compatibility with future PICmicro® products, do not use this instruction.

NOP No Operation

Syntax:	[<i>label</i>] NOP				
Operands:	None				
Operation:	No operation				
Status Affected:	None				
Encoding:	<table border="1" style="display: inline-table; border-collapse: collapse;"> <tr> <td style="padding: 2px 10px;">00</td> <td style="padding: 2px 10px;">0000</td> <td style="padding: 2px 10px;">0xx0</td> <td style="padding: 2px 10px;">0000</td> </tr> </table>	00	0000	0xx0	0000
00	0000	0xx0	0000		
Description:	No operation.				
Words:	1				
Cycles:	1				
Example	NOP				

RETFIE Return from Interrupt

Syntax:	[<i>label</i>] RETFIE				
Operands:	None				
Operation:	TOS → PC, 1 → GIE				
Status Affected:	None				
Encoding:	<table border="1" style="display: inline-table; border-collapse: collapse;"> <tr> <td style="padding: 2px 10px;">00</td> <td style="padding: 2px 10px;">0000</td> <td style="padding: 2px 10px;">0000</td> <td style="padding: 2px 10px;">1001</td> </tr> </table>	00	0000	0000	1001
00	0000	0000	1001		
Description:	Return from Interrupt. Stack is POPed and Top of Stack (TOS) is loaded in the PC. Interrupts are enabled by setting Global Interrupt Enable bit, GIE (INTCON<7>). This is a two-cycle instruction.				
Words:	1				
Cycles:	2				
Example	<pre>RETFIE After Interrupt PC = TOS GIE = 1</pre>				

RETLW Return with Literal in W

Syntax: `[label] RETLW k`

Operands: $0 \leq k \leq 255$

Operation: $k \rightarrow (W)$;
TOS \rightarrow PC

Status Affected: None

Encoding:

11	01xx	kkkk	kkkk
----	------	------	------

Description: The W register is loaded with the eight bit literal 'k'. The program counter is loaded from the top of the stack (the return address). This is a two-cycle instruction.

Words: 1

Cycles: 2

Example

```
CALL TABLE;W contains table
                    ;offset value
    •                ;W now has table
    value
    TABLE
    •
    •
    ADDWF PC ;W = offset
    RETLW k1 ;Begin table
    RETLW k2 ;
    •
    •
    •
    RETLW kn ; End of table

Before Instruction
    W = 0x07
After Instruction
    W = value of k8
```

RETURN Return from Subroutine

Syntax: `[label] RETURN`

Operands: None

Operation: TOS \rightarrow PC

Status Affected: None

Encoding:

00	0000	0000	1000
----	------	------	------

Description: Return from subroutine. The stack is POPed and the top of the stack (TOS) is loaded into the program counter. This is a two-cycle instruction.

Words: 1

Cycles: 2

Example

```
RETURN

After Interrupt
    PC = TOS
```

RLF Rotate Left f through Carry

Syntax: `[label] RLF f,d`

Operands: $0 \leq f \leq 127$
 $d \in [0,1]$

Operation: See description below

Status Affected: C

Encoding:

00	1101	dfff	ffff
----	------	------	------

Description: The contents of register 'f' are rotated one bit to the left through the Carry Flag. If 'd' is 0 the result is placed in the W register. If 'd' is 1 the result is stored back in register 'f'.



Words: 1

Cycles: 1

Example

```
RLF    REG1, 0
```

Before Instruction

```
REG1 = 1110 0110
C     = 0
```

After Instruction

```
REG1 = 1110 0110
W     = 1100 1100
C     = 1
```

PIC16F62X

RRF Rotate Right f through Carry

Syntax: [label] RRF f,d
 Operands: $0 \leq f \leq 127$
 $d \in [0,1]$
 Operation: See description below
 Status Affected: C
 Encoding:

00	1100	dfff	ffff
----	------	------	------

Description: The contents of register 'f' are rotated one bit to the right through the Carry Flag. If 'd' is 0 the result is placed in the W register. If 'd' is 1 the result is placed back in register 'f'.

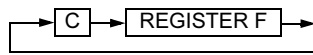

Words: 1
 Cycles: 1
 Example: RRF REG1, 0
 Before Instruction
 REG1 = 1110 0110
 C = 0
 After Instruction
 REG1 = 1110 0110
 W = 0111 0011
 C = 0

SLEEP

Syntax: [label] SLEEP
 Operands: None
 Operation: 00h → WDT,
 0 → WDT prescaler,
 1 → \overline{TO} ,
 0 → \overline{PD}
 Status Affected: \overline{TO} , \overline{PD}
 Encoding:

00	0000	0110	0011
----	------	------	------

Description: The power-down STATUS bit, \overline{PD} is cleared. Timeout STATUS bit, \overline{TO} is set. Watchdog Timer and its prescaler are cleared. The processor is put into SLEEP mode with the oscillator stopped. See Section 14.9 for more details.

Words: 1
 Cycles: 1
 Example: SLEEP

SUBLW Subtract W from Literal

Syntax: [label] SUBLW k
 Operands: $0 \leq k \leq 255$
 Operation: $k - (W) \rightarrow (W)$
 Status Affected: C, DC, Z
 Encoding:

11	110x	kkkk	kkkk
----	------	------	------

Description: The W register is subtracted (2's complement method) from the eight bit literal 'k'. The result is placed in the W register.

Words: 1
 Cycles: 1
 Example 1: SUBLW 0x02
 Before Instruction
 W = 1
 C = ?
 After Instruction
 W = 1
 C = 1; result is positive

Example 2: Before Instruction
 W = 2
 C = ?
 After Instruction
 W = 0
 C = 1; result is zero

Example 3: Before Instruction
 W = 3
 C = ?
 After Instruction
 W = 0xFF
 C = 0; result is negative

SUBWF Subtract W from f

Syntax: [label] SUBWF f,d

Operands: $0 \leq f \leq 127$
 $d \in [0,1]$

Operation: $(f) - (W) \rightarrow (\text{dest})$

Status Affected: C, DC, Z

Encoding:

00	0010	dfff	ffff
----	------	------	------

Description: Subtract (2's complement method) W register from register 'f'. If 'd' is 0 the result is stored in the W register. If 'd' is 1 the result is stored back in register 'f'.

Words: 1

Cycles: 1

Example 1: SUBWF REG1, 1

Before Instruction

REG1 = 3
W = 2
C = ?

After Instruction

REG1 = 1
W = 2
C = 1; result is positive
Z = DC = 1

Example 2: Before Instruction

REG1 = 2
W = 2
C = ?

After Instruction

REG1 = 0
W = 2
C = 1; result is zero
Z = DC = 1

Example 3: Before Instruction

REG1 = 1
W = 2
C = ?

After Instruction

REG1 = 0xFF
W = 2
C = 0; result is negative
Z = DC = 0

SWAPF Swap Nibbles in f

Syntax: [label] SWAPF f,d

Operands: $0 \leq f \leq 127$
 $d \in [0,1]$

Operation: $(f<3:0>) \rightarrow (\text{dest}<7:4>)$,
 $(f<7:4>) \rightarrow (\text{dest}<3:0>)$

Status Affected: None

Encoding:

00	1110	dfff	ffff
----	------	------	------

Description: The upper and lower nibbles of register 'f' are exchanged. If 'd' is 0 the result is placed in W register. If 'd' is 1 the result is placed in register 'f'.

Words: 1

Cycles: 1

Example SWAPF REG1, 0

Before Instruction

REG1 = 0xA5

After Instruction

REG1 = 0xA5
W = 0x5A

TRIS	Load TRIS Register				
Syntax:	[label] TRIS f				
Operands:	$5 \leq f \leq 7$				
Operation:	$(W) \rightarrow \text{TRIS register } f$;				
Status Affected:	None				
Encoding:	<table border="1" style="display: inline-table; border-collapse: collapse;"><tr><td style="padding: 2px 10px;">00</td><td style="padding: 2px 10px;">0000</td><td style="padding: 2px 10px;">0110</td><td style="padding: 2px 10px;">0fff</td></tr></table>	00	0000	0110	0fff
00	0000	0110	0fff		
Description:	The instruction is supported for code compatibility with the PIC16C5X products. Since TRIS registers are readable and writable, the user can directly address them.				
Words:	1				
Cycles:	1				
Example	<div style="border: 1px solid black; padding: 5px; margin-top: 10px;"> <p>To maintain upward compatibility with future PICmicro® products, do not use this instruction.</p> </div>				

PIC16F62X

XORLW Exclusive OR Literal with W

Syntax: [*label*] XORLW *k*

Operands: $0 \leq k \leq 255$

Operation: (W) .XOR. *k* → (W)

Status Affected: Z

Encoding:

11	1010	kkkk	kkkk
----	------	------	------

Description: The contents of the W register are XOR'ed with the eight bit literal '*k*'. The result is placed in the W register.

Words: 1

Cycles: 1

Example: XORLW 0xAF

Before Instruction

W = 0xB5

After Instruction

W = 0x1A

XORWF Exclusive OR W with f

Syntax: [*label*] XORWF *f*,*d*

Operands: $0 \leq f \leq 127$

$d \in [0,1]$

Operation: (W) .XOR. (*f*) → (*dest*)

Status Affected: Z

Encoding:

00	0110	dfff	ffff
----	------	------	------

Description: Exclusive OR the contents of the W register with register '*f*'. If '*d*' is 0 the result is stored in the W register. If '*d*' is 1 the result is stored back in register '*f*'.

Words: 1

Cycles: 1

Example: XORWF REG1, 1

Before Instruction

REG1 = 0xAF

W = 0xB5

After Instruction

REG1 = 0x1A

W = 0xB5

16.0 DEVELOPMENT SUPPORT

The PICmicro[®] microcontrollers are supported with a full range of hardware and software development tools:

- Integrated Development Environment
 - MPLAB[®] IDE Software
- Assemblers/Compilers/Linkers
 - MPASM[™] Assembler
 - MPLAB C17 and MPLAB C18 C Compilers
 - MPLINK[™] Object Linker/
MPLIB[™] Object Librarian
 - MPLAB C30 C Compiler
 - MPLAB ASM30 Assembler/Linker/Library
- Simulators
 - MPLAB SIM Software Simulator
 - MPLAB dsPIC30 Software Simulator
- Emulators
 - MPLAB ICE 2000 In-Circuit Emulator
 - MPLAB ICE 4000 In-Circuit Emulator
- In-Circuit Debugger
 - MPLAB ICD 2
- Device Programmers
 - PRO MATE[®] II Universal Device Programmer
 - PICSTART[®] Plus Development Programmer
- Low Cost Demonstration Boards
 - PICDEM[™] 1 Demonstration Board
 - PICDEM.net[™] Demonstration Board
 - PICDEM 2 Plus Demonstration Board
 - PICDEM 3 Demonstration Board
 - PICDEM 17 Demonstration Board
 - PICDEM 18R Demonstration Board
 - PICDEM LIN Demonstration Board
 - PICDEM USB Demonstration Board
- Evaluation Kits
 - KEELOQ[®]
 - PICDEM MSC
 - microID[®]
 - CAN
 - PowerSmart[®]
 - Analog

16.1 MPLAB Integrated Development Environment Software

The MPLAB IDE software brings an ease of software development previously unseen in the 8/16-bit microcontroller market. The MPLAB IDE is a Windows[®] based application that contains:

- An interface to debugging tools
 - simulator
 - programmer (sold separately)
 - emulator (sold separately)
 - in-circuit debugger (sold separately)
- A full-featured editor with color coded context
- A multiple project manager
- Customizable data windows with direct edit of contents
- High level source code debugging
- Mouse over variable inspection
- Extensive on-line help

The MPLAB IDE allows you to:

- Edit your source files (either assembly or C)
- One touch assemble (or compile) and download to PICmicro emulator and simulator tools (automatically updates all project information)
- Debug using:
 - source files (assembly or C)
 - absolute listing file (mixed assembly and C)
 - machine code

MPLAB IDE supports multiple debugging tools in a single development paradigm, from the cost effective simulators, through low cost in-circuit debuggers, to full-featured emulators. This eliminates the learning curve when upgrading to tools with increasing flexibility and power.

16.2 MPASM Assembler

The MPASM assembler is a full-featured, universal macro assembler for all PICmicro MCUs.

The MPASM assembler generates relocatable object files for the MPLINK object linker, Intel[®] standard HEX files, MAP files to detail memory usage and symbol reference, absolute LST files that contains source lines and generated machine code and COFF files for debugging.

The MPASM assembler features include:

- Integration into MPLAB IDE projects
- User defined macros to streamline assembly code
- Conditional assembly for multi-purpose source files
- Directives that allow complete control over the assembly process

16.3 MPLAB C17 and MPLAB C18 C Compilers

The MPLAB C17 and MPLAB C18 Code Development Systems are complete ANSI C compilers for Microchip's PIC17CXXX and PIC18CXXX family of microcontrollers. These compilers provide powerful integration capabilities, superior code optimization and ease of use not found with other compilers.

For easy source level debugging, the compilers provide symbol information that is optimized to the MPLAB IDE debugger.

16.4 MPLINK Object Linker/ MPLIB Object Librarian

The MPLINK object linker combines relocatable objects created by the MPASM assembler and the MPLAB C17 and MPLAB C18 C compilers. It can link relocatable objects from pre-compiled libraries, using directives from a linker script.

The MPLIB object librarian manages the creation and modification of library files of pre-compiled code. When a routine from a library is called from a source file, only the modules that contain that routine will be linked in with the application. This allows large libraries to be used efficiently in many different applications.

The object linker/library features include:

- Efficient linking of single libraries instead of many smaller files
- Enhanced code maintainability by grouping related modules together
- Flexible creation of libraries with easy module listing, replacement, deletion and extraction

16.5 MPLAB C30 C Compiler

The MPLAB C30 C compiler is a full-featured, ANSI compliant, optimizing compiler that translates standard ANSI C programs into dsPIC30F assembly language source. The compiler also supports many command-line options and language extensions to take full advantage of the dsPIC30F device hardware capabilities, and afford fine control of the compiler code generator.

MPLAB C30 is distributed with a complete ANSI C standard library. All library functions have been validated and conform to the ANSI C library standard. The library includes functions for string manipulation, dynamic memory allocation, data conversion, time-keeping, and math functions (trigonometric, exponential and hyperbolic). The compiler provides symbolic information for high level source debugging with the MPLAB IDE.

16.6 MPLAB ASM30 Assembler, Linker, and Librarian

MPLAB ASM30 assembler produces relocatable machine code from symbolic assembly language for dsPIC30F devices. MPLAB C30 compiler uses the assembler to produce its object file. The assembler generates relocatable object files that can then be archived or linked with other relocatable object files and archives to create an executable file. Notable features of the assembler include:

- Support for the entire dsPIC30F instruction set
- Support for fixed-point and floating-point data
- Command line interface
- Rich directive set
- Flexible macro language
- MPLAB IDE compatibility

16.7 MPLAB SIM Software Simulator

The MPLAB SIM software simulator allows code development in a PC hosted environment by simulating the PICmicro series microcontrollers on an instruction level. On any given instruction, the data areas can be examined or modified and stimuli can be applied from a file, or user defined key press, to any pin. The execution can be performed in Single-Step, Execute Until Break, or Trace mode.

The MPLAB SIM simulator fully supports symbolic debugging using the MPLAB C17 and MPLAB C18 C Compilers, as well as the MPASM assembler. The software simulator offers the flexibility to develop and debug code outside of the laboratory environment, making it an excellent, economical software development tool.

16.8 MPLAB SIM30 Software Simulator

The MPLAB SIM30 software simulator allows code development in a PC hosted environment by simulating the dsPIC30F series microcontrollers on an instruction level. On any given instruction, the data areas can be examined or modified and stimuli can be applied from a file, or user defined key press, to any of the pins.

The MPLAB SIM30 simulator fully supports symbolic debugging using the MPLAB C30 C Compiler and MPLAB ASM30 assembler. The simulator runs in either a Command Line mode for automated tasks, or from MPLAB IDE. This high speed simulator is designed to debug, analyze and optimize time intensive DSP routines.

16.9 MPLAB ICE 2000 High Performance Universal In-Circuit Emulator

The MPLAB ICE 2000 universal in-circuit emulator is intended to provide the product development engineer with a complete microcontroller design tool set for PICmicro microcontrollers. Software control of the MPLAB ICE 2000 in-circuit emulator is advanced by the MPLAB Integrated Development Environment, which allows editing, building, downloading and source debugging from a single environment.

The MPLAB ICE 2000 is a full-featured emulator system with enhanced trace, trigger and data monitoring features. Interchangeable processor modules allow the system to be easily reconfigured for emulation of different processors. The universal architecture of the MPLAB ICE in-circuit emulator allows expansion to support new PICmicro microcontrollers.

The MPLAB ICE 2000 in-circuit emulator system has been designed as a real-time emulation system with advanced features that are typically found on more expensive development tools. The PC platform and Microsoft® Windows 32-bit operating system were chosen to best make these features available in a simple, unified application.

16.10 MPLAB ICE 4000 High Performance Universal In-Circuit Emulator

The MPLAB ICE 4000 universal in-circuit emulator is intended to provide the product development engineer with a complete microcontroller design tool set for high-end PICmicro microcontrollers. Software control of the MPLAB ICE in-circuit emulator is provided by the MPLAB Integrated Development Environment, which allows editing, building, downloading and source debugging from a single environment.

The MPLAB ICE 4000 is a premium emulator system, providing the features of MPLAB ICE 2000, but with increased emulation memory and high speed performance for dsPIC30F and PIC18XXXX devices. Its advanced emulator features include complex triggering and timing, up to 2 Mb of emulation memory, and the ability to view variables in real-time.

The MPLAB ICE 4000 in-circuit emulator system has been designed as a real-time emulation system with advanced features that are typically found on more expensive development tools. The PC platform and Microsoft Windows 32-bit operating system were chosen to best make these features available in a simple, unified application.

16.11 MPLAB ICD 2 In-Circuit Debugger

Microchip's In-Circuit Debugger, MPLAB ICD 2, is a powerful, low cost, run-time development tool, connecting to the host PC via an RS-232 or high speed USB interface. This tool is based on the FLASH PICmicro MCUs and can be used to develop for these and other PICmicro microcontrollers. The MPLAB ICD 2 utilizes the in-circuit debugging capability built into the FLASH devices. This feature, along with Microchip's In-Circuit Serial Programming™ (ICSP™) protocol, offers cost effective in-circuit FLASH debugging from the graphical user interface of the MPLAB Integrated Development Environment. This enables a designer to develop and debug source code by setting breakpoints, single-stepping and watching variables, CPU status and peripheral registers. Running at full speed enables testing hardware and applications in real-time. MPLAB ICD 2 also serves as a development programmer for selected PICmicro devices.

16.12 PRO MATE II Universal Device Programmer

The PRO MATE II is a universal, CE compliant device programmer with programmable voltage verification at VDDMIN and VDDMAX for maximum reliability. It features an LCD display for instructions and error messages and a modular detachable socket assembly to support various package types. In Stand-Alone mode, the PRO MATE II device programmer can read, verify, and program PICmicro devices without a PC connection. It can also set code protection in this mode.

16.13 PICSTART Plus Development Programmer

The PICSTART Plus development programmer is an easy-to-use, low cost, prototype programmer. It connects to the PC via a COM (RS-232) port. MPLAB Integrated Development Environment software makes using the programmer simple and efficient. The PICSTART Plus development programmer supports most PICmicro devices up to 40 pins. Larger pin count devices, such as the PIC16C92X and PIC17C76X, may be supported with an adapter socket. The PICSTART Plus development programmer is CE compliant.

16.14 PICDEM 1 PICmicro Demonstration Board

The PICDEM 1 demonstration board demonstrates the capabilities of the PIC16C5X (PIC16C54 to PIC16C58A), PIC16C61, PIC16C62X, PIC16C71, PIC16C8X, PIC17C42, PIC17C43 and PIC17C44. All necessary hardware and software is included to run basic demo programs. The sample microcontrollers provided with the PICDEM 1 demonstration board can be programmed with a PRO MATE II device programmer, or a PICSTART Plus development programmer. The PICDEM 1 demonstration board can be connected to the MPLAB ICE in-circuit emulator for testing. A prototype area extends the circuitry for additional application components. Features include an RS-232 interface, a potentiometer for simulated analog input, push button switches and eight LEDs.

16.15 PICDEM.net Internet/Ethernet Demonstration Board

The PICDEM.net demonstration board is an Internet/Ethernet demonstration board using the PIC18F452 microcontroller and TCP/IP firmware. The board supports any 40-pin DIP device that conforms to the standard pinout used by the PIC16F877 or PIC18C452. This kit features a user friendly TCP/IP stack, web server with HTML, a 24L256 Serial EEPROM for Xmodem download to web pages into Serial EEPROM, ICSP/MPLAB ICD 2 interface connector, an Ethernet interface, RS-232 interface, and a 16 x 2 LCD display. Also included is the book and CD-ROM "TCP/IP Lean, Web Servers for Embedded Systems," by Jeremy Bentham

16.16 PICDEM 2 Plus Demonstration Board

The PICDEM 2 Plus demonstration board supports many 18-, 28-, and 40-pin microcontrollers, including PIC16F87X and PIC18FXX2 devices. All the necessary hardware and software is included to run the demonstration programs. The sample microcontrollers provided with the PICDEM 2 demonstration board can be programmed with a PRO MATE II device programmer, PICSTART Plus development programmer, or MPLAB ICD 2 with a Universal Programmer Adapter. The MPLAB ICD 2 and MPLAB ICE in-circuit emulators may also be used with the PICDEM 2 demonstration board to test firmware. A prototype area extends the circuitry for additional application components. Some of the features include an RS-232 interface, a 2 x 16 LCD display, a piezo speaker, an on-board temperature sensor, four LEDs, and sample PIC18F452 and PIC16F877 FLASH microcontrollers.

16.17 PICDEM 3 PIC16C92X Demonstration Board

The PICDEM 3 demonstration board supports the PIC16C923 and PIC16C924 in the PLCC package. All the necessary hardware and software is included to run the demonstration programs.

16.18 PICDEM 17 Demonstration Board

The PICDEM 17 demonstration board is an evaluation board that demonstrates the capabilities of several Microchip microcontrollers, including PIC17C752, PIC17C756A, PIC17C762 and PIC17C766. A programmed sample is included. The PRO MATE II device programmer, or the PICSTART Plus development programmer, can be used to reprogram the device for user tailored application development. The PICDEM 17 demonstration board supports program download and execution from external on-board FLASH memory. A generous prototype area is available for user hardware expansion.

16.19 PICDEM 18R PIC18C601/801 Demonstration Board

The PICDEM 18R demonstration board serves to assist development of the PIC18C601/801 family of Microchip microcontrollers. It provides hardware implementation of both 8-bit Multiplexed/De-multiplexed and 16-bit Memory modes. The board includes 2 Mb external FLASH memory and 128 Kb SRAM memory, as well as serial EEPROM, allowing access to the wide range of memory types supported by the PIC18C601/801.

16.20 PICDEM LIN PIC16C43X Demonstration Board

The powerful LIN hardware and software kit includes a series of boards and three PICmicro microcontrollers. The small footprint PIC16C432 and PIC16C433 are used as slaves in the LIN communication and feature on-board LIN transceivers. A PIC16F874 FLASH microcontroller serves as the master. All three microcontrollers are programmed with firmware to provide LIN bus communication.

16.21 PICDEM USB PIC16C7X5 Demonstration Board

The PICDEM USB Demonstration Board shows off the capabilities of the PIC16C745 and PIC16C765 USB microcontrollers. This board provides the basis for future USB products.

16.22 Evaluation and Programming Tools

In addition to the PICDEM series of circuits, Microchip has a line of evaluation kits and demonstration software for these products.

- KEELOQ evaluation and programming tools for Microchip's HCS Secure Data Products
- CAN developers kit for automotive network applications
- Analog design boards and filter design software
- PowerSmart battery charging evaluation/calibration kits
- IrDA® development kit
- microID development and RFLab™ development software
- SEEVAL® designer kit for memory evaluation and endurance calculations
- PICDEM MSC demo boards for Switching mode power supply, high power IR driver, delta sigma ADC, and flow rate sensor

Check the Microchip web page and the latest Product Line Card for the complete list of demonstration and evaluation kits.

TABLE 16-1: DEVELOPMENT TOOLS FROM MICROCHIP

Tool	PIC12CXX	PIC12FXX	PIC1400	PIC16C5X	PIC16C6X	PIC16CXX	PIC16C43X	PIC16F62X	PIC16C7X	PIC16C7XX	PIC16C7X5	PIC16C8X	PIC16F8XX	PIC16C9XX	PIC17C4X	PIC17C7XX	PIC18CXX2	P18CX01	PIC18FXX	dSPIC30F
MPLAB Integrated Development Environment	✓	✓	✓	✓	✓	✓	✓	✓	✓	✓	✓	✓	✓	✓	✓	✓	✓	✓	✓	✓
MPLAB C17 C Compiler																				
MPLAB C18 C Compiler																				
MPASM Assembler/ MPLINK Object Linker	✓	✓	✓	✓	✓	✓	✓	✓	✓	✓	✓	✓	✓	✓	✓	✓	✓	✓	✓	✓
MPLAB C30 C Compiler																				✓
MPLAB ASM30 Assembler/Linker/Librarian																				✓
MPLAB ICE 2000 In-Circuit Emulator	✓	✓	✓	✓	✓	✓	✓	✓	✓	✓	✓	✓	✓	✓	✓	✓	✓	✓	✓	✓
MPLAB ICE 4000 In-Circuit Emulator	✓	✓		✓	✓	✓			✓	✓		✓		✓	✓	✓	✓	✓	✓	✓
MPLAB ICD 2 In-Circuit Debugger		✓			✓				✓				✓					✓		✓
PICSTART Plus Entry Level Development Programmer	✓	✓	✓	✓	✓	✓	✓	✓	✓	✓	✓	✓	✓	✓	✓	✓	✓	✓	✓	✓
PRO MATE II Universal Device Programmer	✓	✓	✓	✓	✓	✓	✓	✓	✓	✓	✓	✓	✓	✓	✓	✓	✓	✓	✓	✓
PICDEM 1 Demonstration Board				✓					†					✓						
PICDEM.net Demonstration Board																	✓			
PICDEM 2 Plus Demonstration Board					†					†							✓			
PICDEM 3 Demonstration Board																				
PICDEM 14A Demonstration Board			✓																	
PICDEM 17 Demonstration Board															✓					
PICDEM 18R Demonstration Board																		✓		
PICDEM LIN Demonstration Board							✓						✓							
PICDEM USB Demonstration Board																			✓	✓

* Contact the Microchip web site at www.microchip.com for information on how to use the MPLAB ICD In-Circuit Debugger (DV164001) with PIC16C62, 63, 64, 65, 66, 72, 73, 74, 76, 77.

** Contact Microchip Technology Inc. for availability date.

† Development tool is available on select devices.

17.0 ELECTRICAL SPECIFICATIONS

Absolute Maximum Ratings†

Ambient temperature under bias	-40 to +125°C
Storage temperature	-65°C to +150°C
Voltage on VDD with respect to VSS	-0.3 to +6.5V
Voltage on MCLR and RA4 with respect to VSS	-0.3 to +14V
Voltage on all other pins with respect to VSS	-0.3V to VDD + 0.3V
Total power dissipation ⁽¹⁾	800 mW
Maximum current out of VSS pin	300 mA
Maximum current into VDD pin	250 mA
Input clamp current, I _{IK} (V _I < 0 or V _I > VDD).....	± 20 mA
Output clamp current, I _{OK} (V _O < 0 or V _O > VDD).....	± 20 mA
Maximum output current sunk by any I/O pin.....	25 mA
Maximum output current sourced by any I/O pin	25 mA
Maximum current sunk by PORTA and PORTB.....	200 mA
Maximum current sourced by PORTA and PORTB	200 mA

Note 1: Power dissipation is calculated as follows: $P_{DIS} = V_{DD} \times \{I_{DD} - \sum I_{OH}\} + \sum \{(V_{DD} - V_{OH}) \times I_{OH}\} + \sum (V_{OL} \times I_{OL})$

† **NOTICE:** Stresses above those listed under “Absolute Maximum Ratings” may cause permanent damage to the device. This is a stress rating only and functional operation of the device at those or any other conditions above those indicated in the operation listings of this specification is not implied. Exposure to maximum rating conditions for extended periods may affect device reliability.

Note: Voltage spikes below VSS at the MCLR pin, inducing currents greater than 80 mA, may cause latchup. Thus, a series resistor of 50-100 Ω should be used when applying a “low” level to the MCLR pin rather than pulling this pin directly to VSS

PIC16F62X

FIGURE 17-1: PIC16F62X VOLTAGE-FREQUENCY GRAPH, $0^{\circ}\text{C} \leq \text{TA} \leq +70^{\circ}\text{C}$

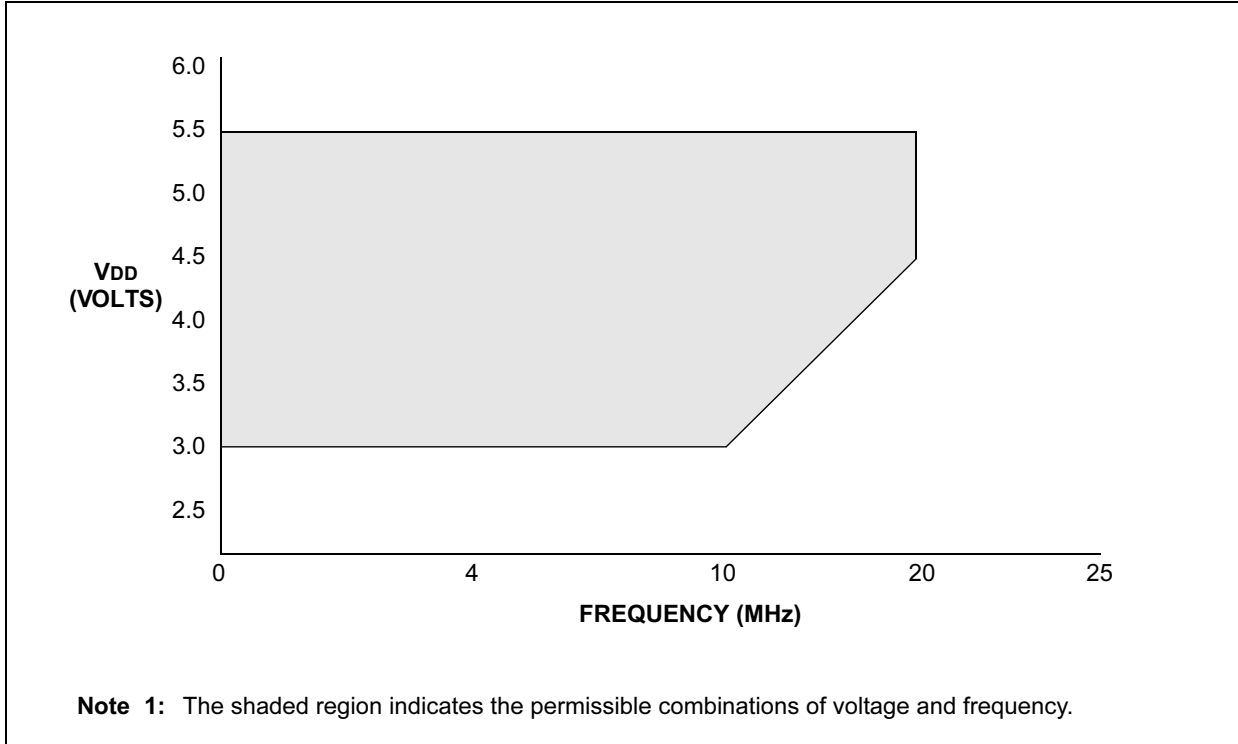

FIGURE 17-2: PIC16F62X VOLTAGE-FREQUENCY GRAPH, $-40^{\circ}\text{C} \leq \text{TA} < 0^{\circ}\text{C}$, $+70^{\circ}\text{C} < \text{TA} \leq 85^{\circ}\text{C}$

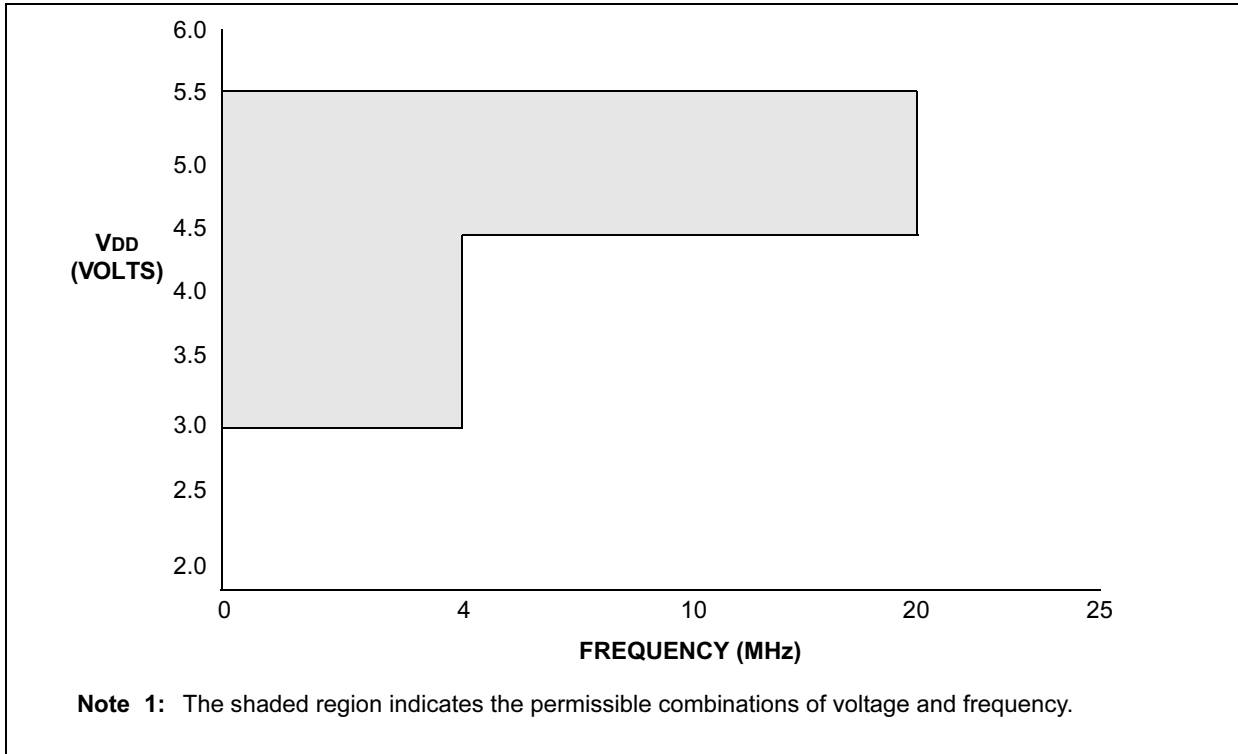

FIGURE 17-3: PIC16LF62X VOLTAGE-FREQUENCY GRAPH, $0^{\circ}\text{C} \leq \text{TA} \leq +70^{\circ}\text{C}$

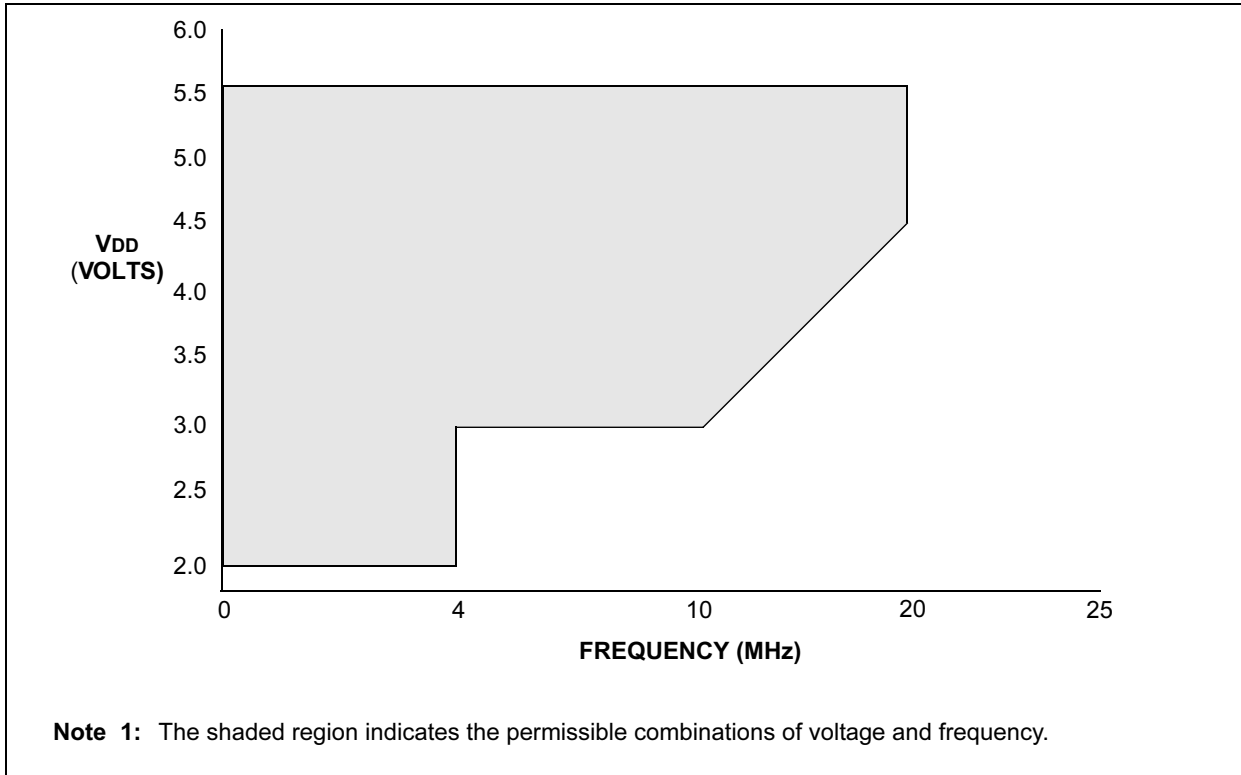
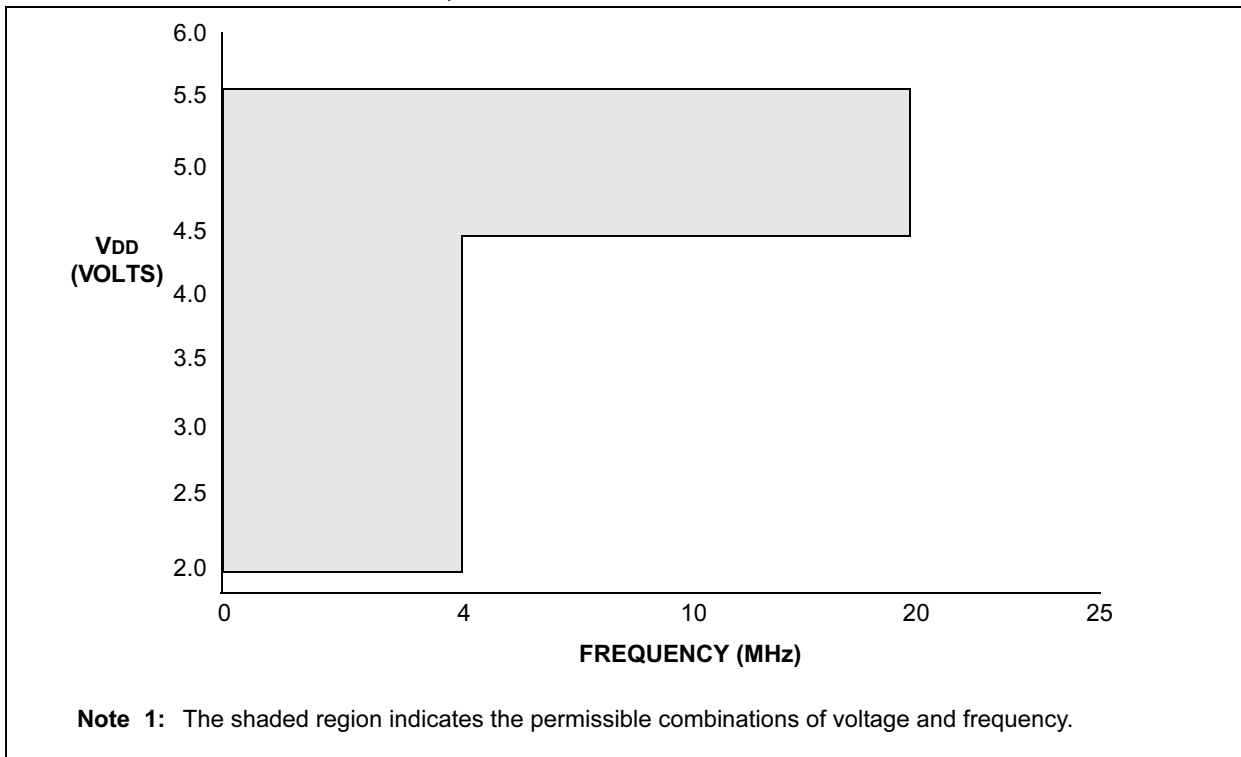

FIGURE 17-4: PIC16LF62X VOLTAGE-FREQUENCY GRAPH, $-40^{\circ}\text{C} \leq \text{TA} < 0^{\circ}\text{C}$, $+70^{\circ}\text{C} < \text{TA} \leq 85^{\circ}\text{C}$



PIC16F62X

17.1 DC Characteristics: PIC16F62X-04 (Commercial, Industrial, Extended) PIC16F62X-20 (Commercial, Industrial, Extended) PIC16LF62X-04 (Commercial, Industrial)

PIC16LF62X-04 (Commercial, Industrial)		Standard Operating Conditions (unless otherwise stated) Operating temperature -40°C ≤ Ta ≤ +85°C for industrial and 0°C ≤ Ta ≤ +70°C for commercial					
PIC16F62X-04 PIC16F62X-20 (Commercial, Industrial, Extended)		Standard Operating Conditions (unless otherwise stated) Operating temperature -40°C ≤ Ta ≤ +85°C for industrial and 0°C ≤ Ta ≤ +70°C for commercial and -40°C ≤ Ta ≤ +125°C for extended					
Param No.	Sym	Characteristic/Device	Min	Typ†	Max	Units	Conditions
D001	VDD	Supply Voltage					
		PIC16LF62X	2.0	—	5.5	V	
D001		PIC16F62X	3.0	—	5.5	V	
D002	VDR	RAM Data Retention Voltage⁽¹⁾	—	1.5	—	V	Device in SLEEP mode*
D003	VPOR	VDD Start Voltage to ensure Power-on Reset	—	VSS	—	V	See section on Power-on Reset for details
D004	SVDD	VDD Rise Rate to ensure Power-on Reset	0.05	—	—	V/ms	See section on Power-on Reset for details*
D005	VBOD	Brown-out Detect Voltage	3.65	4.0	4.35	V	BODEN configuration bit is set BODEN configuration bit is set, Extended
			3.65	—	4.4	V	
D010 D013	IDD	Supply Current^{(2), (5)}					
		PIC16LF62X	—	0.30	0.6	mA	Fosc = 4.0 MHz, VDD = 2.0 ⁽⁵⁾
			—	1.10	2.0	mA	Fosc = 4.0 MHz, VDD = 5.5*
			—	4.0	7.0	mA	Fosc = 20.0 MHz, VDD = 5.5
			—	3.80	6.0	mA	Fosc = 20.0 MHz, VDD = 4.5*
			—	—	2.0	mA	Fosc = 10.0 MHz, VDD = 3.0 ⁽⁶⁾
			—	20	30	μA	Fosc = 32 kHz, VDD = 2.0
D010 D013 D014	PIC16F62X	—	0.60	0.7	mA	Fosc = 4.0 MHz, VDD = 3.0	
		—	1.10	2.0	mA	Fosc = 4.0 MHz, VDD = 5.5*	
		—	4.0	7.0	mA	Fosc = 20.0 MHz, VDD = 5.5	
		—	3.80	6.0	mA	Fosc = 20.0 MHz, VDD = 4.5*	
		—	—	2.0	mA	Fosc = 10.0 MHz, VDD = 3.0 ⁽⁶⁾	
		—	20	30	μA	Fosc = 32 kHz, VDD = 3.0*	

Legend: Rows with standard voltage device data only are shaded for improved readability.

* These parameters are characterized but not tested.

† Data in "Typ" column is at 5.0V, 25°C, unless otherwise stated. These parameters are for design guidance only and are not tested.

Note 1: This is the limit to which VDD can be lowered in SLEEP mode without losing RAM data.

Note 2: The supply current is mainly a function of the operating voltage and frequency. Other factors such as I/O pin loading and switching rate, oscillator type, internal code execution pattern, and temperature also have an impact on the current consumption.

The test conditions for all IDD measurements in active Operation mode are:

OSC1 = external square wave, from rail to rail; all I/O pins tri-stated, pulled to VDD,

MCLR = VDD; WDT enabled/disabled as specified.

Note 3: The power-down current in SLEEP mode does not depend on the oscillator type. Power-down current is measured with the part in SLEEP mode, with all I/O pins in hi-impedance state and tied to VDD or VSS.

Note 4: The Δ current is the additional current consumed when this peripheral is enabled. This current should be added to the base IDD or IPD measurement.

Note 5: For RC osc configuration, current through REXT is not included. The current through the resistor can be estimated by the formula $I_r = V_{DD}/2R_{EXT}$ (mA) with REXT in kΩ.

Note 6: Commercial temperature only.

17.1 DC Characteristics: PIC16F62X-04 (Commercial, Industrial, Extended) PIC16F62X-20 (Commercial, Industrial, Extended) PIC16LF62X-04 (Commercial, Industrial)

Param No.		Sym	Characteristic/Device	Min	Typ†	Max	Units	Conditions
PIC16LF62X-04 (Commercial, Industrial)			Standard Operating Conditions (unless otherwise stated) Operating temperature -40°C ≤ Ta ≤ +85°C for industrial and 0°C ≤ Ta ≤ +70°C for commercial					
PIC16F62X-04 PIC16F62X-20 (Commercial, Industrial, Extended)			Standard Operating Conditions (unless otherwise stated) Operating temperature -40°C ≤ Ta ≤ +85°C for industrial and 0°C ≤ Ta ≤ +70°C for commercial and -40°C ≤ Ta ≤ +125°C for extended					
D020		IPD	Power Down Current^{*(2), (3)}					
			PIC16LF62X	—	0.20	2.0	μA	VDD = 2.0
				—	0.20	2.2	μA	VDD = 5.5
D020			PIC16F62X	—	0.20	2.2	μA	VDD = 3.0
				—	0.20	5.0	μA	VDD = 4.5*
				—	0.20	9.0	μA	VDD = 5.5
				—	2.70	15.0	μA	VDD = 5.5 Extended
D023		ΔIWDT	WDT Current ⁽⁴⁾	—	6.0	15	μA	VDD = 3.0V
		ΔIBOD	Brown-out Detect Current ⁽⁴⁾	—	75	125	μA	BOD enabled, VDD = 5.0V
		ΔICOMP	Comparator Current for each Comparator ⁽⁴⁾	—	30	50	μA	VDD = 3.0V
		ΔIVREF	VREF Current ⁽⁴⁾	—		135	μA	VDD = 3.0V
D023		ΔIWDT	WDT Current ⁽⁴⁾	—	6.0	20	μA	VDD = 4.0V, Commercial, Industrial
		ΔIBOD	Brown-out Detect Current ⁽⁴⁾	—	75	25	μA	VDD = 4.0V, Extended
		ΔICOMP	Comparator Current for each Comparator ⁽⁴⁾	—	30	50	μA	BOD enabled, VDD = 5.0V
		ΔIVREF	VREF Current ⁽⁴⁾	—		135	μA	VDD = 4.0V

Legend: Rows with standard voltage device data only are shaded for improved readability.

* These parameters are characterized but not tested.

† Data in "Typ" column is at 5.0V, 25°C, unless otherwise stated. These parameters are for design guidance only and are not tested.

Note 1: This is the limit to which VDD can be lowered in SLEEP mode without losing RAM data.

Note 2: The supply current is mainly a function of the operating voltage and frequency. Other factors such as I/O pin loading and switching rate, oscillator type, internal code execution pattern, and temperature also have an impact on the current consumption.

The test conditions for all IDD measurements in active Operation mode are:

OSC1 = external square wave, from rail to rail; all I/O pins tri-stated, pulled to VDD,

MCLR = VDD; WDT enabled/disabled as specified.

Note 3: The power-down current in SLEEP mode does not depend on the oscillator type. Power-down current is measured with the part in SLEEP mode, with all I/O pins in hi-impedance state and tied to VDD or VSS.

Note 4: The Δ current is the additional current consumed when this peripheral is enabled. This current should be added to the base IDD or IPD measurement.

Note 5: For RC osc configuration, current through REXT is not included. The current through the resistor can be estimated by the formula $I_r = V_{DD}/2R_{EXT}$ (mA) with REXT in kΩ.

PIC16F62X

17.2 DC Characteristics: PIC16F62X (Commercial, Industrial, Extended) PIC16LF62X (Commercial, Industrial)

DC CHARACTERISTICS		Standard Operating Conditions (unless otherwise stated) Operating temperature $-40^{\circ}\text{C} \leq \text{TA} \leq +85^{\circ}\text{C}$ for industrial and $0^{\circ}\text{C} \leq \text{TA} \leq +70^{\circ}\text{C}$ for commercial and $-40^{\circ}\text{C} \leq \text{TA} \leq +125^{\circ}\text{C}$ for extended Operating voltage V_{DD} range as described in DC spec Table 17-1 and Table 17-2					
Param. No.	Sym	Characteristic/Device	Min	Typ†	Max	Unit	Conditions
	VIL	Input Low Voltage					
D030		I/O ports with TTL buffer	VSS	—	0.8	V	VDD = 4.5V to 5.5V otherwise (Note1)
D031		with Schmitt Trigger input	VSS	—	0.15 VDD	V	
D032		MCLR, RA4/T0CKI, OSC1 (in ER mode)	VSS	—	0.2 VDD	V	
D033		OSC1 (in XT and HS)	VSS	—	0.3 VDD	V	
		OSC1 (in LP)	VSS	—	0.6 VDD - 1.0	V	
	VIH	Input High Voltage					
D040		I/O ports with TTL buffer	2.0V .25 VDD + 0.8V	—	VDD	V	VDD = 4.5V to 5.5V otherwise (Note1)
D041		with Schmitt Trigger input	0.8 VDD	—	VDD	V	
D042		MCLR RA4/T0CKI	0.8 VDD	—	VDD	V	
D043		OSC1 (XT, HS and LP)	0.7 VDD	—	VDD	V	
D043A		OSC1 (in ER mode)	0.9 VDD	—	VDD	V	
D070	IPURB	PORTB weak pull-up current	50	200	400	μA	
	IIL	Input Leakage Current^{(2), (3)}					
D060		I/O ports (Except PORTA)	—	—	±1.0	μA	VSS ≤ VPIN ≤ VDD, pin at hi-impedance VSS ≤ VPIN ≤ VDD, pin at hi-impedance VSS ≤ VPIN ≤ VDD VSS ≤ VPIN ≤ VDD, XT, HS and LP osc configuration
D061		PORTA	—	—	±0.5	μA	
D063		RA4/T0CKI	—	—	±1.0	μA	
		OSC1, MCLR	—	—	±5.0	μA	
	VOL	Output Low Voltage					
D080		I/O ports	—	—	0.6	V	IOL=8.5 mA, VDD=4.5V, -40° to +85°C IOL=7.0 mA, VDD=4.5V, +125°C IOL=1.6 mA, VDD=4.5V, -40° to +85°C IOL=1.2 mA, VDD=4.5V, +125°C
D083		OSC2/CLKOUT (ER only)	—	—	0.6	V	
			—	—	0.6	V	
			—	—	0.6	V	
	VOH	Output High Voltage⁽³⁾					
D090		I/O ports (Except RA4)	VDD - 0.7	—	—	V	IOH=-3.0 mA, VDD=4.5V, -40° to +85°C IOH=-2.5 mA, VDD=4.5V, +125°C IOH=-1.3 mA, VDD=4.5V, -40° to +85°C IOH=-1.0 mA, VDD=4.5V, +125°C
D092		OSC2/CLKOUT (ER only)	VDD - 0.7	—	—	V	
			VDD - 0.7	—	—	V	
			VDD - 0.7	—	—	V	
D150	VOD	Open-Drain High Voltage		—	8.5	V	RA4 pin PIC16F62X, PIC16LF62X*
		Capacitive Loading Specs on Output Pins					
D100*	COSC2	OSC2 pin		—	15	pF	In XT, HS and LP modes when external clock used to drive OSC1.
D101*	Cio	All I/O pins/OSC2 (in ER mode)		—	50	pF	

* These parameters are characterized but not tested.

† Data in "Typ" column is at 5.0V, 25°C unless otherwise stated. These parameters are for design guidance only and are not tested.

- Note**
- 1: In ER oscillator configuration, the OSC1 pin is a Schmitt Trigger input. It is not recommended that the PIC16F62X be driven with external clock in ER mode.
 - 2: The leakage current on the MCLR pin is strongly dependent on applied voltage level. The specified levels represent normal operating conditions. Higher leakage current may be measured at different input voltages.
 - 3: Negative current is defined as coming out of the pin.

TABLE 17-1: COMPARATOR SPECIFICATIONS

Operating Conditions: 3.0V < VDD < 5.5V, -40°C < TA < +125°C, unless otherwise stated.							
Param No.	Characteristics	Sym	Min	Typ	Max	Units	Comments
D300	Input offset voltage	V _{IOFF}	—	±5.0	±10	mV	
D301*	Input Common mode voltage	V _{ICM}	0	—	V _{DD} - 1.5	V	
D302*	Common Mode Rejection Ratio	CMRR	55	—	—	db	
300*	Response Time ⁽¹⁾	T _{RESP}	—	150	400	ns	16F62X
300A					600	ns	16LF62X
301	Comparator Mode Change to Output Valid*	T _{MC2OV}	—	—	10	µs	

* These parameters are characterized but not tested.

Note 1: Response time measured with one comparator input at (V_{DD} - 1.5)/2 while the other input transitions from V_{SS} to V_{DD}.

TABLE 17-2: VOLTAGE REFERENCE SPECIFICATIONS

Operating Conditions: 3.0V < VDD < 5.5V, -40°C < TA < +125°C, unless otherwise stated.							
Spec No.	Characteristics	Sym	Min	Typ	Max	Units	Comments
D310	Resolution	V _{RES}	V _{DD} /24	—	V _{DD} /32	LSb	
D311	Absolute Accuracy	V _{Raa}	—	—	1/4	LSb	Low Range (VRR = 1)
			—	—	1/2	LSb	High Range (VRR = 0)
D312*	Unit Resistor Value (R)	V _{Rur}	—	2k	—	Ω	
310*	Settling Time ⁽¹⁾	T _{set}	—	—	10	µs	

* These parameters are characterized but not tested.

Note 1: Settling time measured while VRR = 1 and VR<3:0> transitions from 0000 to 1111.

PIC16F62X

17.3 Timing Parameter Symbology

The timing parameter symbols have been created with one of the following formats:

1. TppS2ppS
2. TppS

T			
F	Frequency	T	Time

Lowercase subscripts (pp) and their meanings:

pp			
ck	CLKOUT	osc	OSC1
io	I/O port	t0	T0CKI
mc	MCLR		

Uppercase letters and their meanings:

S			
F	Fall	P	Period
H	High	R	Rise
I	Invalid (Hi-impedance)	V	Valid
L	Low	Z	Hi-Impedance

FIGURE 17-5: LOAD CONDITIONS

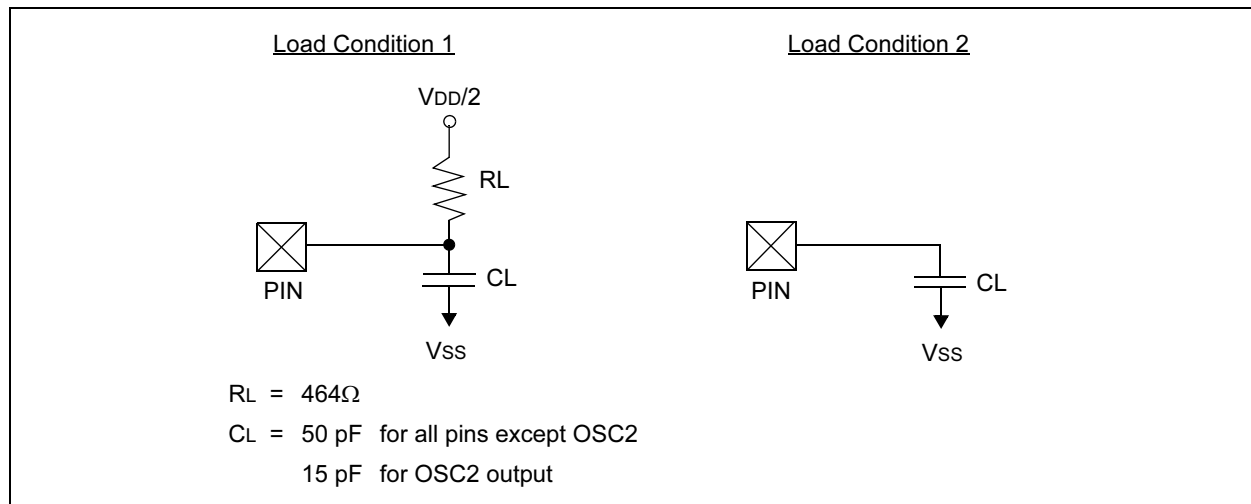

TABLE 17-3: DC CHARACTERISTICS: PIC16F62X, PIC16LF62X

DC Characteristics			Standard Operating Conditions (unless otherwise stated)				
Parameter No.	Sym	Characteristic	Min	Typ†	Max	Units	Conditions
Data EEPROM Memory							
D120	ED	Endurance	1M*	10M	—	E/W	25°C at 5V V _{MIN} = Minimum operating voltage
D121	VDRW	VDD for read/write	V _{MIN}	—	5.5	V	
D122	TDEW	Erase/Write cycle time	—	4	8*	ms	
Program FLASH Memory							
D130	EP	Endurance	1000*	10000	—	E/W	V _{MIN} = Minimum operating voltage
D131	VPR	VDD for read	V _{min}	—	5.5	V	
D132	VPEW	VDD for erase/write	4.5	—	5.5	V	
D133	TPEW	Erase/Write cycle time	—	4	8*	ms	

* These parameters are characterized but not tested.

† Data in "Typ" column is at 5.0V, 25°C unless otherwise stated. These parameters are for design guidance only and are not tested.

17.4 Timing Diagrams and Specifications

FIGURE 17-6: EXTERNAL CLOCK TIMING

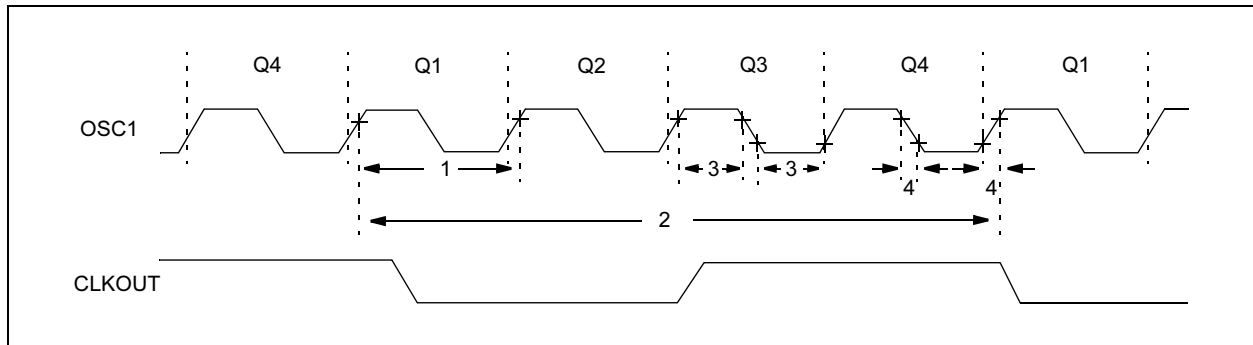

PIC16F62X

TABLE 17-4: EXTERNAL CLOCK TIMING REQUIREMENTS

Param No.	Sym	Characteristic	Min	Typ†	Max	Units	Conditions
	Fosc	External CLKIN Frequency ⁽¹⁾	DC	—	4	MHz	XT and ER Osc mode, V _{DD} = 5.0V
			DC	—	20	MHz	HS Osc mode
DC	—		200	kHz	LP Osc mode		
		Oscillator Frequency ⁽¹⁾	0.1	—	4	MHz	ER Osc mode, V _{DD} = 5.0V
			1	—	4	MHz	XT Osc mode
			1	—	20	MHz	HS Osc mode
			1	—	200	kHz	LP Osc mode
			3.65	4	4.28	MHz	INTRC mode (fast), V _{DD} = 5.0V
				37	kHz	INTRC mode (slow)	
4	INTRC	Internal Calibrated RC	3.65	4.00	4.28	MHz	V _{DD} = 5.0V
5	ER	External Biased ER Frequency	10 kHz		8 MHz		V _{DD} = 5.0V
1	Tosc	External CLKIN Period ⁽¹⁾	250	—	—	ns	XT and ER Osc mode
			50	—	—	ns	HS Osc mode
5	—		—	μs	LP Osc mode		
		Oscillator Period ⁽¹⁾	250	—	—	ns	ER Osc mode
			250	—	10,000	ns	XT Osc mode
			50	—	1,000	ns	HS Osc mode
			5			μs	LP Osc mode
				250		ns	INTRC mode (fast)
		27	μs	INTRC mode (slow)			
2	Tcy	Instruction Cycle Time	1.0	T _{CY}	DC	ns	T _{CY} = 4/FOSC
3	TosL, TosH	External CLKIN (OSC1) High External CLKIN Low	100 *	—	—	ns	XT oscillator, TosC L/H duty cycle*

* These parameters are characterized but not tested.

† Data in “Typ” column is at 5.0V, 25°C unless otherwise stated. These parameters are for design guidance only and are not tested.

Note 1: Instruction cycle period (T_{cy}) equals four times the input oscillator time-based period. All specified values are based on characterization data for that particular oscillator type under standard operating conditions with the device executing code. Exceeding these specified limits may result in an unstable oscillator operation and/or higher than expected current consumption. All devices are tested to operate at “Min.” values with an external clock applied to the OSC1 pin. When an external clock input is used, the “Max” cycle time limit is “DC” (no clock) for all devices.

FIGURE 17-7: CLKOUT AND I/O TIMING

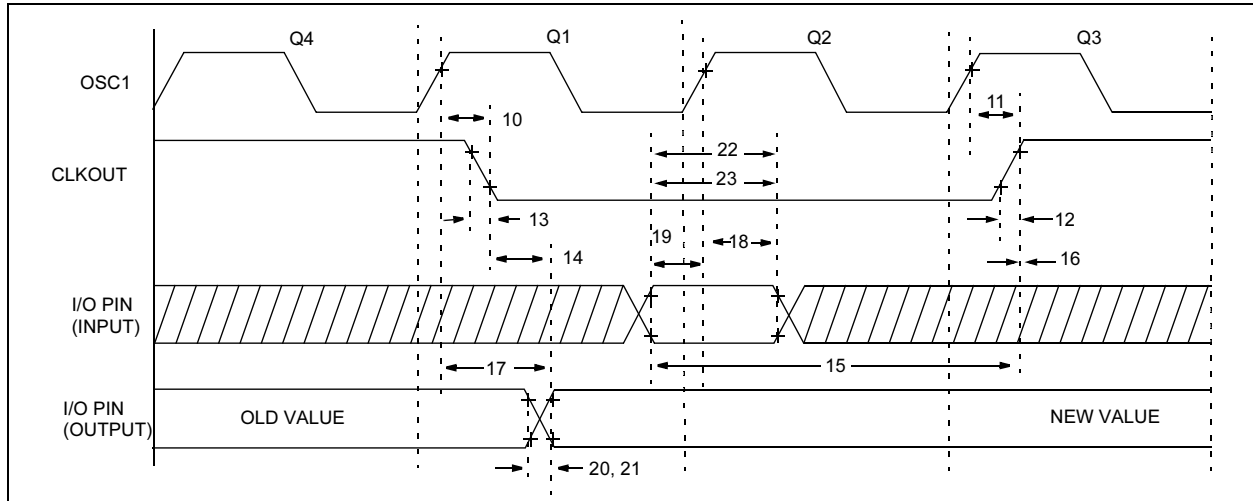

TABLE 17-5: CLKOUT AND I/O TIMING REQUIREMENTS

Param No.	Sym	Characteristic		Min	Typ†	Max	Units
10*	TosH2ckL	OSC1↑ to CLKOUT↓	16F62X	—	75	200	ns
10A*			16LF62X	—	—	400	ns
11*	TosH2ckH	OSC1↑ to CLKOUT↑	16F62X	—	75	200	ns
11A*			16LF62X	—	—	400	ns
12*	TckR	CLKOUT rise time	16F62X	—	35	100	ns
12A*			16LF62X	—	—	200	ns
13*	TckF	CLKOUT fall time	16F62X	—	35	100	ns
13A*			16LF62X	—	—	200	ns
14*	TckL2ioV	CLKOUT ↓ to Port out valid		—	—	20	ns
15*	TioV2ckH	Port in valid before CLKOUT ↑	16F62X	Tosc+200 ns	—	—	ns
			16LF62X	Tosc=400 ns	—	—	ns
16*	TckH2ioI	Port in hold after CLKOUT ↑		0	—	—	ns
17*	TosH2ioV	OSC1↑ (Q1 cycle) to Port out valid	16F62X	—	50	150*	ns
			16LF62X	—	—	300	ns
18*	TosH2ioI	OSC1↑ (Q2 cycle) to Port input invalid (I/O in hold time)		100 200	—	—	ns

* These parameters are characterized but not tested.

† Data in "Typ" column is at 5.0V, 25°C unless otherwise stated. These parameters are for design guidance only and are not tested.

PIC16F62X

FIGURE 17-8: RESET, WATCHDOG TIMER, OSCILLATOR START-UP TIMER AND POWER-UP TIMER TIMING

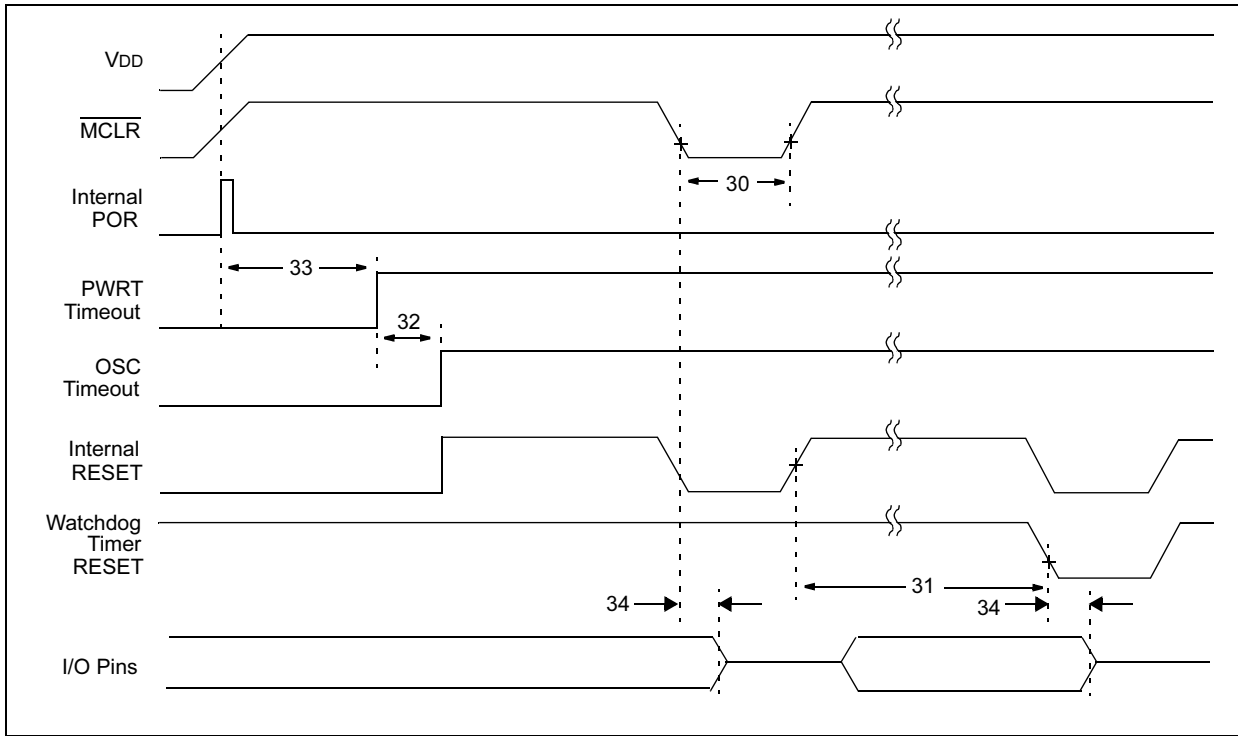

FIGURE 17-9: BROWN-OUT DETECT TIMING

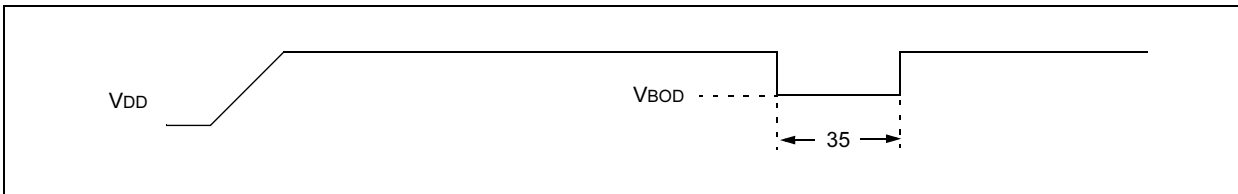

TABLE 17-6: RESET, WATCHDOG TIMER, OSCILLATOR START-UP TIMER AND POWER-UP TIMER REQUIREMENTS

Param No.	Sym	Characteristic	Min	Typ†	Max	Units	Conditions
30	Tmcl	MCLR Pulse Width (low)	2000 TBD	— TBD	— TBD	ns ms	VDD = 5V, -40°C to +85°C Extended temperature
31	Twdt	Watchdog Timer Timeout Period (No Prescaler)	7 TBD	18 TBD	33 TBD	ms ms	VDD = 5V, -40°C to +85°C Extended temperature
32	Tost	Oscillation Start-up Timer Period	—	1024Tosc	—	—	Tosc = OSC1 period
33*	Tpwrt	Power-up Timer Period	28 TBD	72 TBD	132 TBD	ms ms	VDD = 5V, -40°C to +85°C Extended temperature
34	TIOZ	I/O Hi-impedance from MCLR Low or Watchdog Timer Reset	—	—	2.0	μs	
35	TBOD	Brown-out Detect pulse width	100	—	—	μs	VDD ≤ VBOD (D005)

* These parameters are characterized but not tested.

† Data in "Typ" column is at 5.0V, 25°C unless otherwise stated. These parameters are for design guidance only and are not tested.

FIGURE 17-10: TIMER0 AND TIMER1 EXTERNAL CLOCK TIMINGS

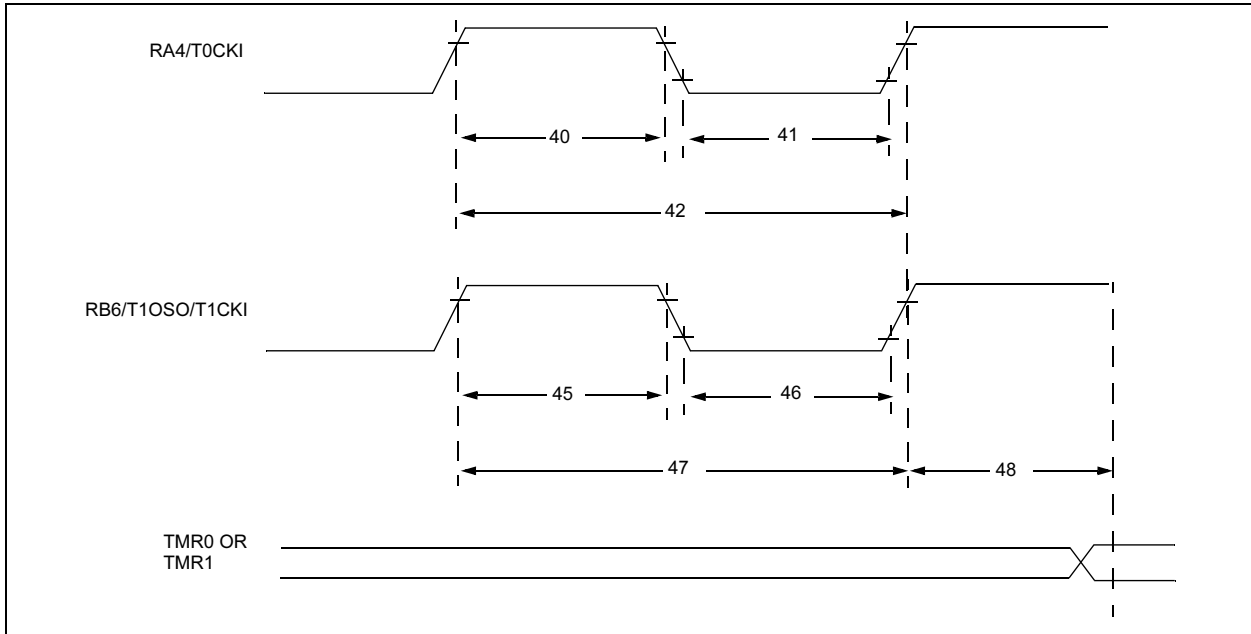

PIC16F62X

TABLE 17-7: TIMER0 AND TIMER1 EXTERNAL CLOCK REQUIREMENTS

Param No.	Sym	Characteristic		Min	Typ†	Max	Units	Conditions	
40*	Tt0H	T0CKI High Pulse Width	No Prescaler	$0.5T_{CY} + 20$	—	—	ns		
			With Prescaler	10	—	—	ns		
41*	Tt0L	T0CKI Low Pulse Width	No Prescaler	$0.5T_{CY} + 20$	—	—	ns		
			With Prescaler	10	—	—	ns		
42*	Tt0P	T0CKI Period		Greater of: $\frac{T_{CY} + 40}{N}$	—	—	ns	N = prescale value (2, 4, ..., 256)	
45*	Tt1H	T1CKI High Time	Synchronous, No Prescaler	$0.5T_{CY} + 20$	—	—	ns		
			Synchronous, with Prescaler	16F62X	15	—	—	ns	
				16LF62X	25	—	—	ns	
			Asynchronous	16F62X	30	—	—	ns	
16LF62X	50	—		—	ns				
46*	Tt1L	T1CKI Low Time	Synchronous, No Prescaler	$0.5T_{CY} + 20$	—	—	ns		
			Synchronous, with Prescaler	16F62X	15	—	—	ns	
				16LF62X	25	—	—	ns	
			Asynchronous	16F62X	30	—	—	ns	
16LF62X	50	—		—	ns				
47*	Tt1P	T1CKI input period	Synchronous	16F62X	Greater of: $\frac{T_{CY} + 40}{N}$	—	—	ns	N = prescale value (1, 2, 4, 8)
				16LF62X	Greater of: $\frac{T_{CY} + 40}{N}$	—	—	—	
			Asynchronous	16F62X	60	—	—	ns	
				16LF62X	100	—	—	ns	
	Ft1	Timer1 oscillator input frequency range (oscillator enabled by setting bit T1OSCEN)		DC	—	200	kHz		
48	TCKEZtmr1	Delay from external clock edge to timer increment		$2T_{osc}$	—	$7T_{osc}$	—		

* These parameters are characterized but not tested.

† Data in "Typ" column is at 5V, 25°C unless otherwise stated. These parameters are for design guidance only and are not tested.

FIGURE 17-11: CAPTURE/COMPARE/PWM TIMINGS

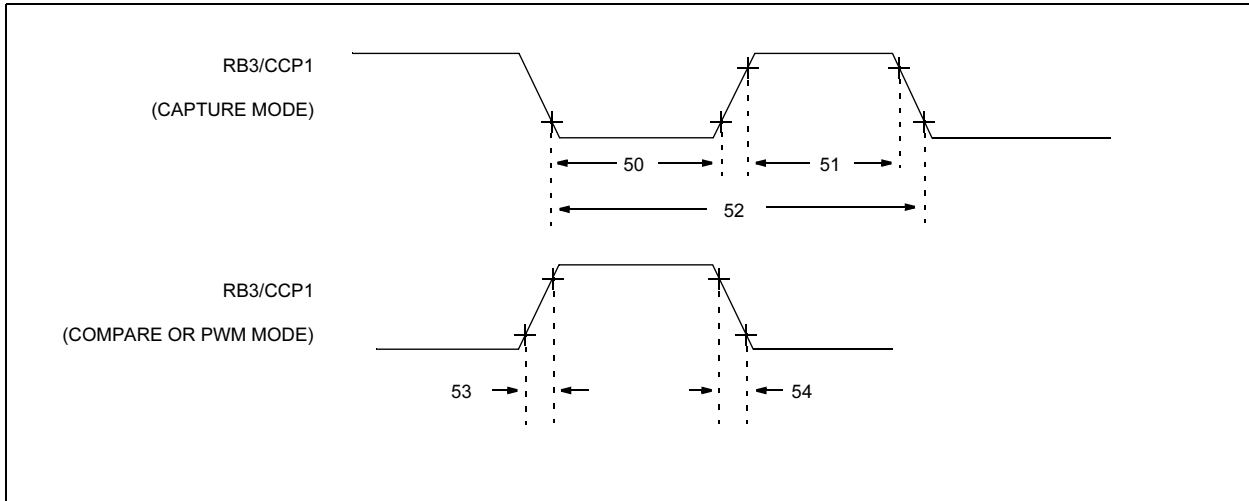

TABLE 17-8: CAPTURE/COMPARE/PWM REQUIREMENTS

Param No.	Sym	Characteristic		Min	Typ†	Max	Units	Conditions	
50*	TccL	CCP input low time	No Prescaler	$0.5T_{CY} + 20$	—	—	ns		
			With Prescaler	16F62X	10	—	—		ns
				16LF62X	20	—	—		ns
51*	TccH	CCP input high time	No Prescaler	$0.5T_{CY} + 20$	—	—	ns		
			With Prescaler	16F62X	10	—	—		ns
				16LF62X	20	—	—		ns
52*	TccP	CCP input period		$\frac{3T_{CY} + 40}{N}$	—	—	ns	N = prescale value (1,4 or 16)	
53*	TccR	CCP output rise time	16F62X		10	25	ns		
			16LF62X		25	45	ns		
54*	TccF	CCP output fall time	16F62X		10	25	ns		
			16LF62X		25	45	ns		

* These parameters are characterized but not tested.

† Data in "Typ" column is at 5V, 25°C unless otherwise stated. These parameters are for design guidance only and are not tested.

FIGURE 17-12: TIMER0 CLOCK TIMING

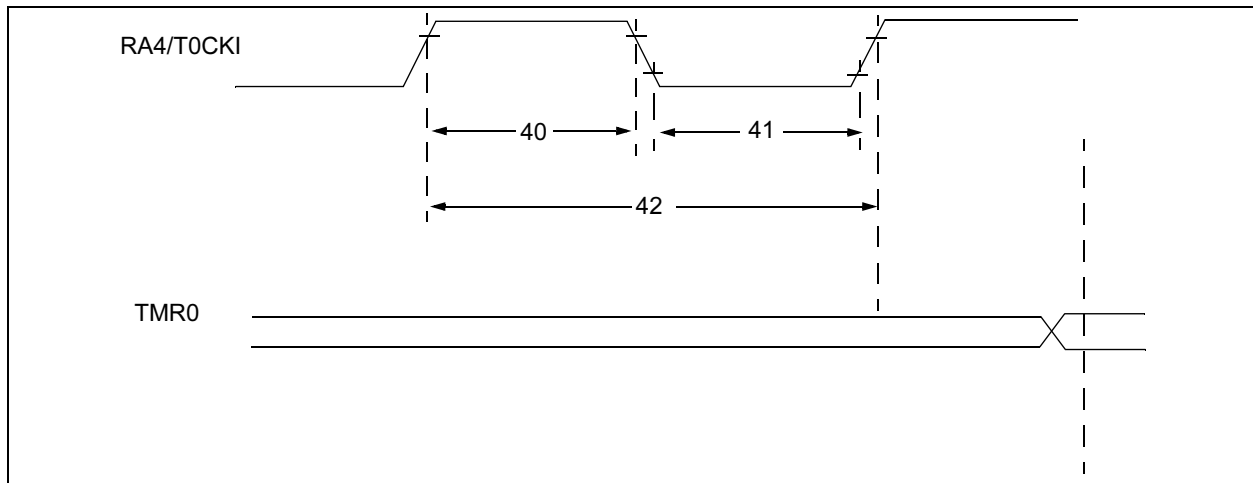

TABLE 17-9: TIMER0 CLOCK REQUIREMENTS

Param No.	Sym	Characteristic		Min	Typ†	Max	Units	Conditions
40	Tt0H	T0CKI High Pulse Width	No Prescaler	$0.5 T_{CY} + 20^*$	—	—	ns	
			With Prescaler	10^*	—	—	ns	
41	Tt0L	T0CKI Low Pulse Width	No Prescaler	$0.5 T_{CY} + 20^*$	—	—	ns	
			With Prescaler	10^*	—	—	ns	
42	Tt0P	T0CKI Period		$\frac{T_{CY} + 40^*}{N}$	—	—	ns	N = prescale value (1, 2, 4, ..., 256)

* These parameters are characterized but not tested.

† Data in "Typ" column is at 5.0V, 25°C unless otherwise stated. These parameters are for design guidance only and are not tested.

PIC16F62X

NOTES:

18.0 DC AND AC CHARACTERISTICS GRAPHS AND TABLES

In some graphs or tables, the data presented is outside specified operating range (i.e., outside specified V_{DD} range). This is for information only and devices are ensured to operate properly only within the specified range.

The data presented in this section is a statistical summary of data collected on units from different lots over a period of time and matrix samples. 'Typical' represents the mean of the distribution at 25°C. 'max or min.' represents (mean + 3σ) or (mean - 3σ) respectively, where σ is standard deviation, over the whole temperature range.

Note: The graphs and tables provided in this section are for design guidance and are not tested.

FIGURE 18-1: TYPICAL I_{DD} vs F_{OSC} OVER V_{DD} – HS MODE

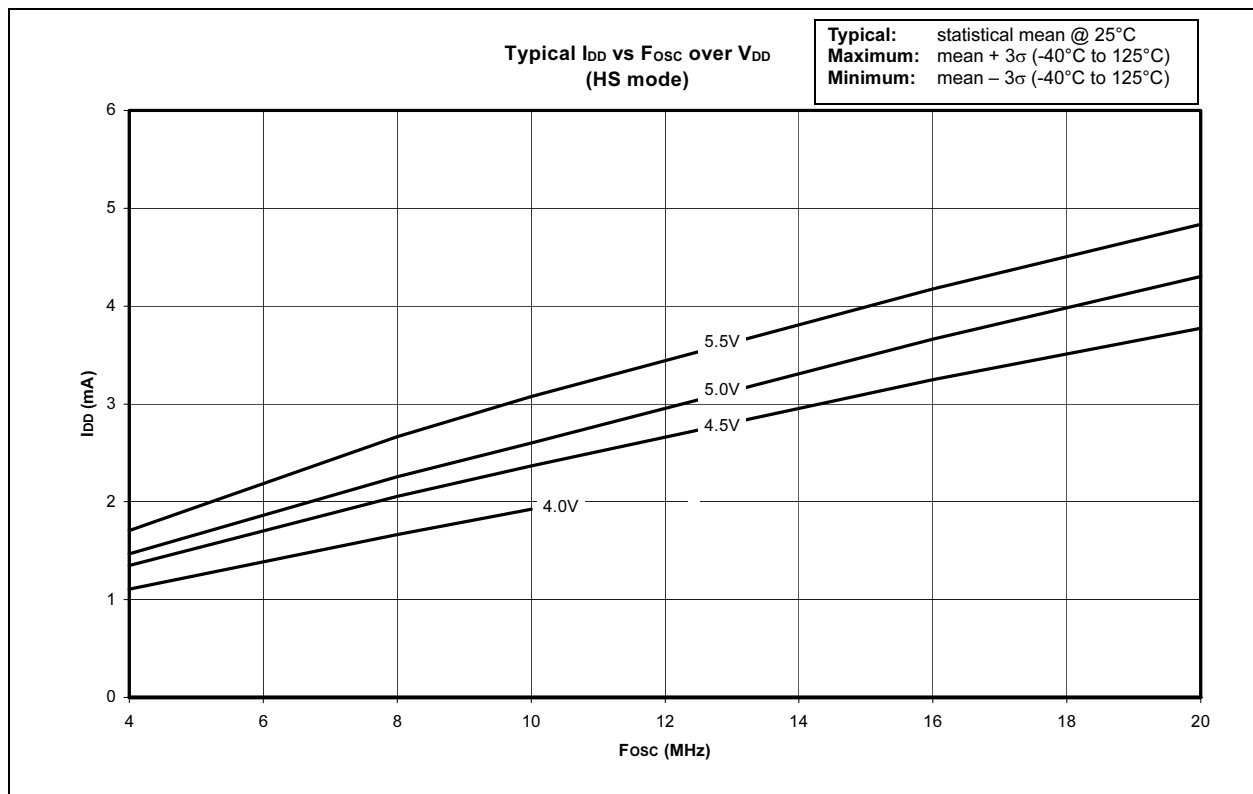

PIC16F62X

Note: The graphs and tables provided in this section are for design guidance and are not tested.

FIGURE 18-2: MAXIMUM I_{DD} vs F_{OSC} OVER V_{DD} (HS MODE)

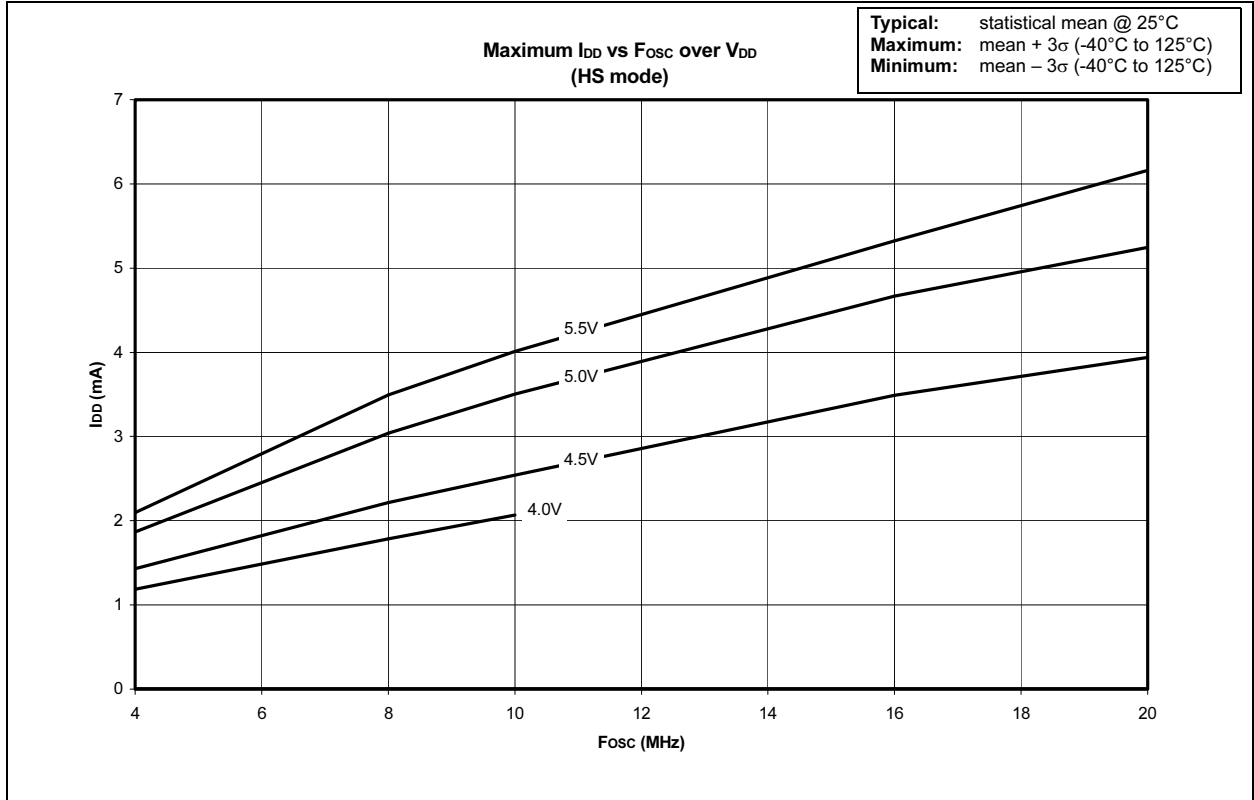
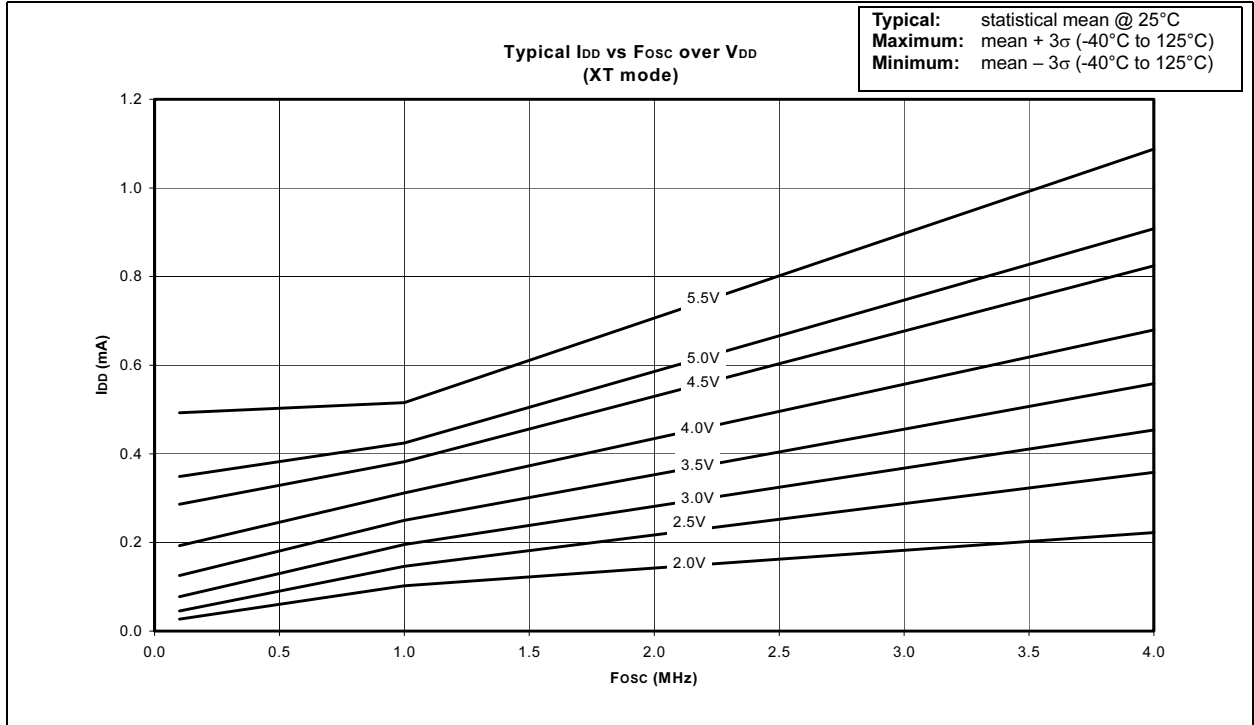

FIGURE 18-3: TYPICAL I_{DD} vs F_{OSC} OVER V_{DD} (XT MODE)



Note: The graphs and tables provided in this section are for design guidance and are not tested.

FIGURE 18-4: TYPICAL I_{DD} vs F_{osc} OVER V_{DD} (XT MODE)

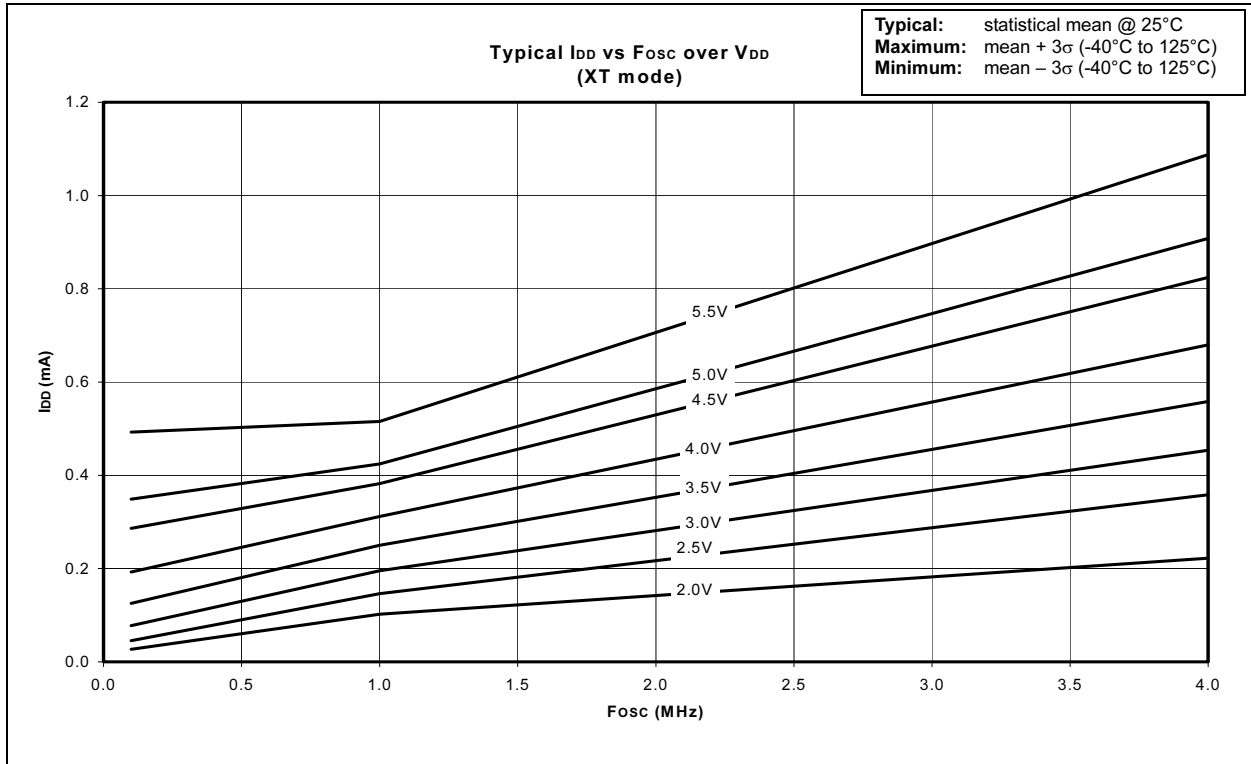
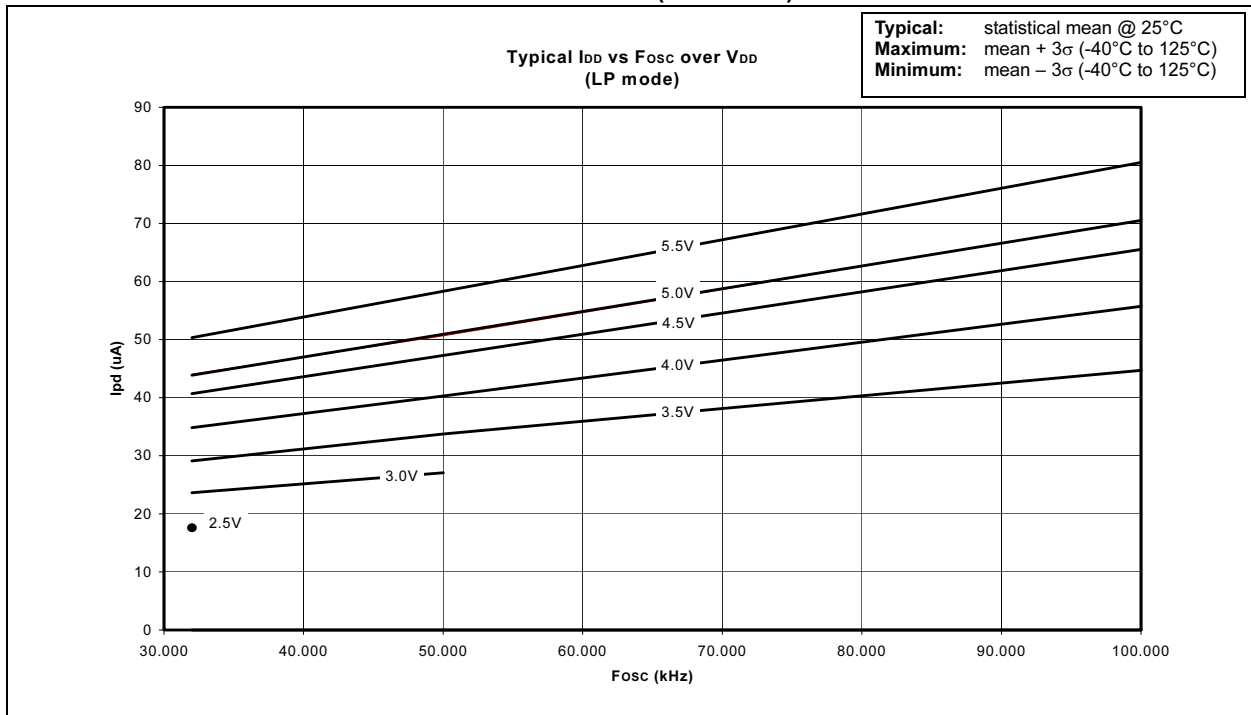

FIGURE 18-5: TYPICAL I_{DD} vs F_{osc} OVER V_{DD} (LP MODE)



PIC16F62X

Note: The graphs and tables provided in this section are for design guidance and are not tested.

FIGURE 18-6: MAXIMUM I_{DD} vs F_{OSC} OVER V_{DD} (LP MODE)

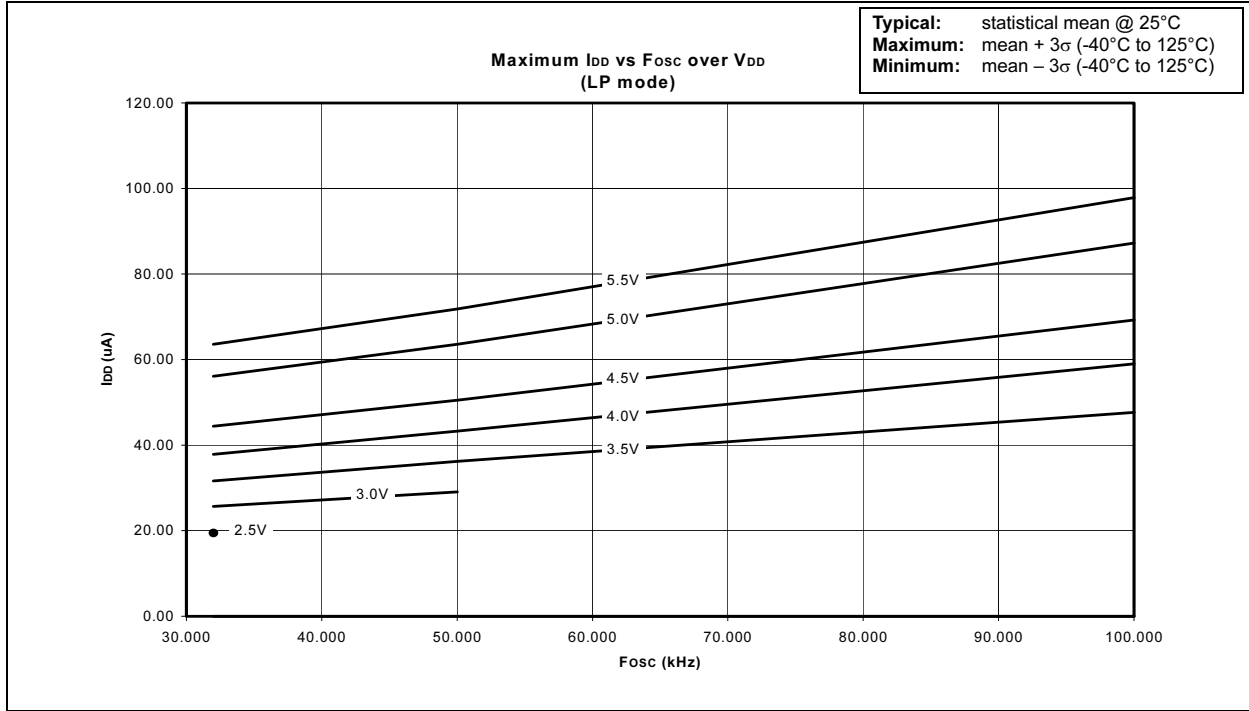
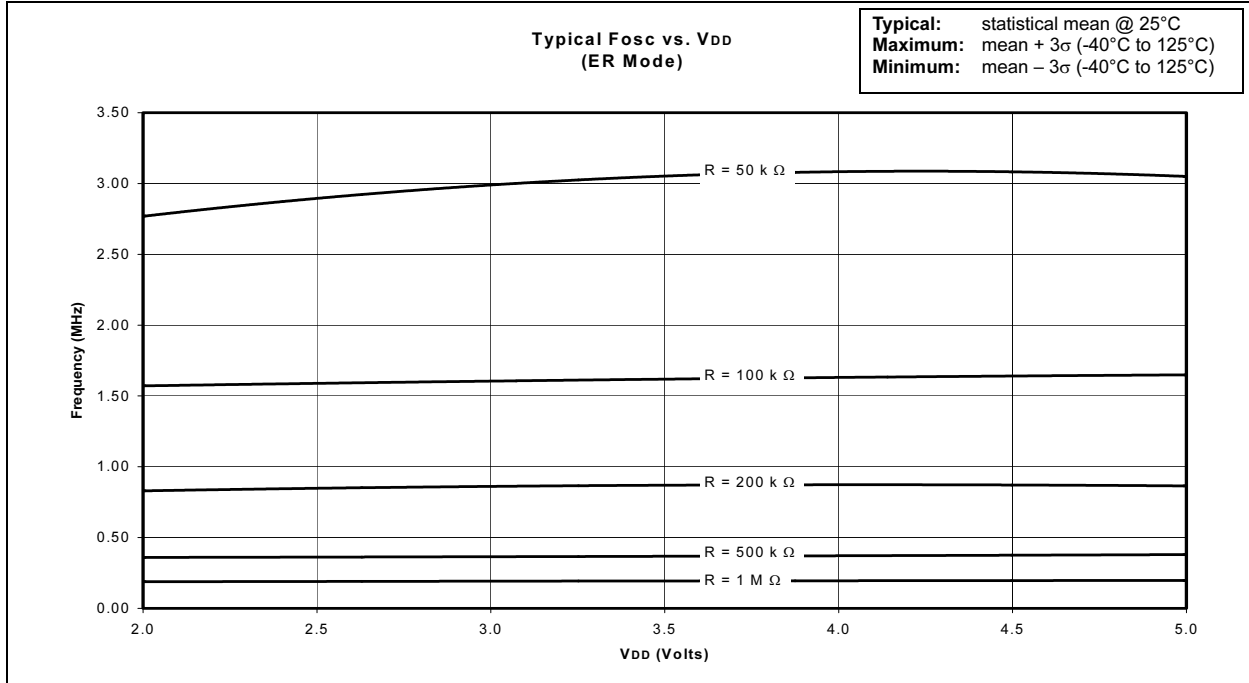

FIGURE 18-7: TYPICAL F_{OSC} vs V_{DD} (ER MODE)



Note: The graphs and tables provided in this section are for design guidance and are not tested.

FIGURE 18-8: TYPICAL INTERNAL RC Fosc vs VDD TEMPERATURE (-40 TO 125°C) INTERNAL 4 MHz OSCILLATOR

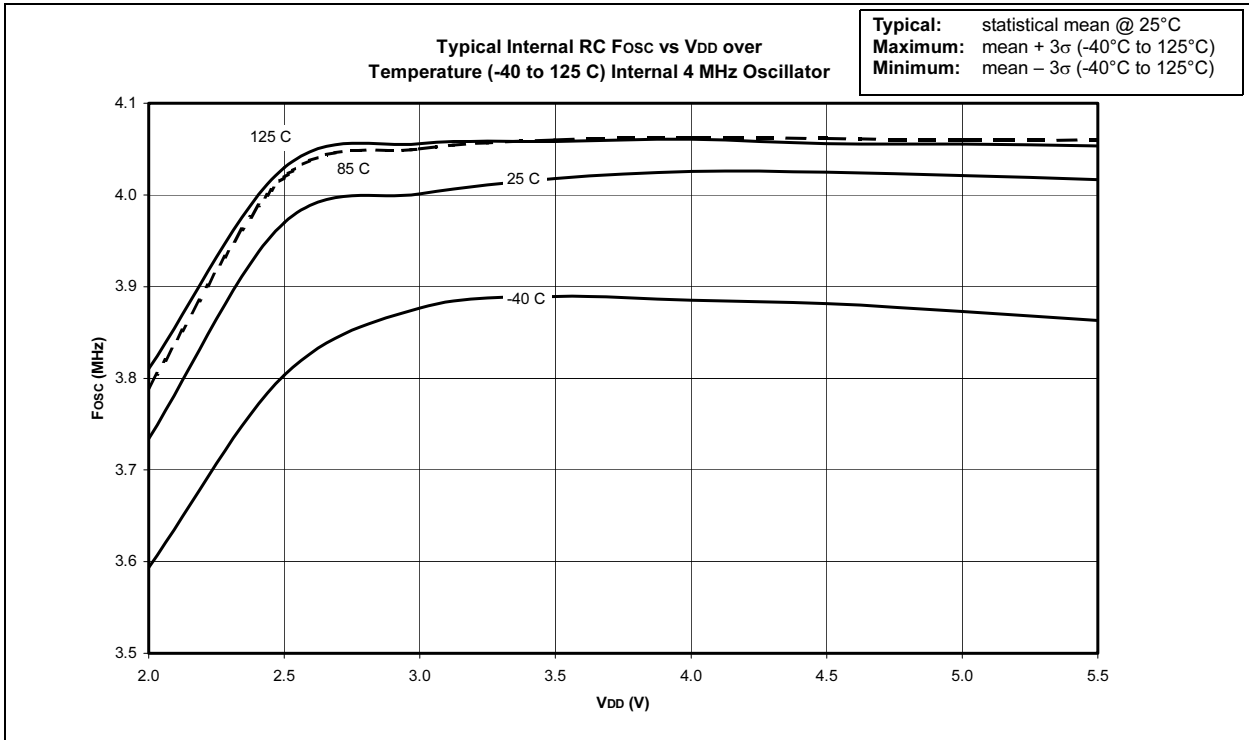
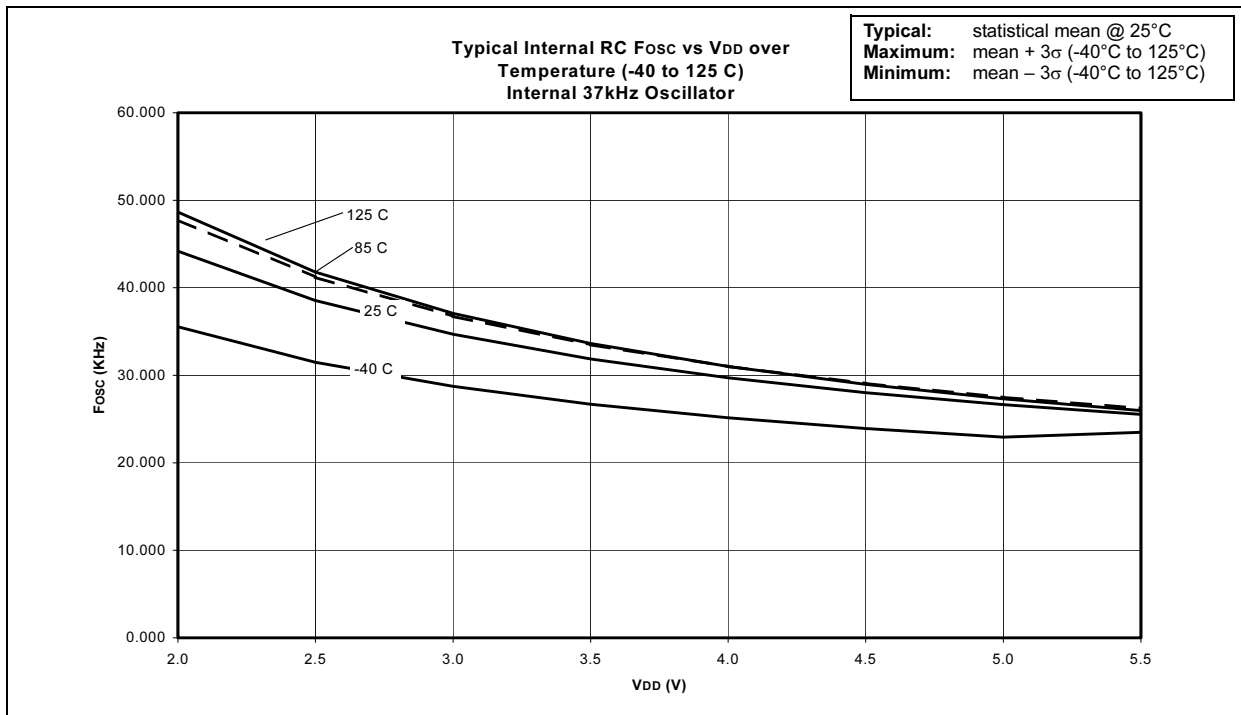

FIGURE 18-9: TYPICAL INTERNAL RC Fosc vs VDD OVER TEMPERATURE (-40 TO 125°C) INTERNAL 37 kHz OSCILLATOR



PIC16F62X

Note: The graphs and tables provided in this section are for design guidance and are not tested.

FIGURE 18-10: I_{PD} vs V_{DD} SLEEP MODE, ALL PERIPHERALS DISABLED

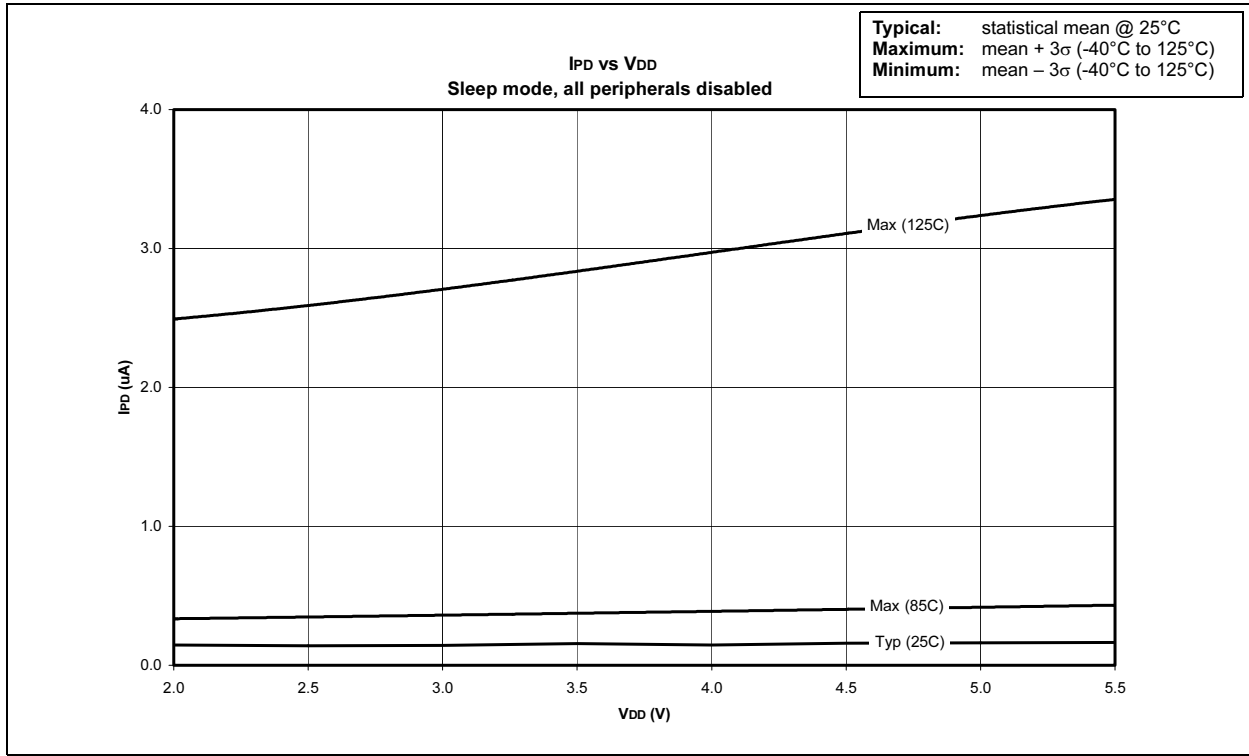
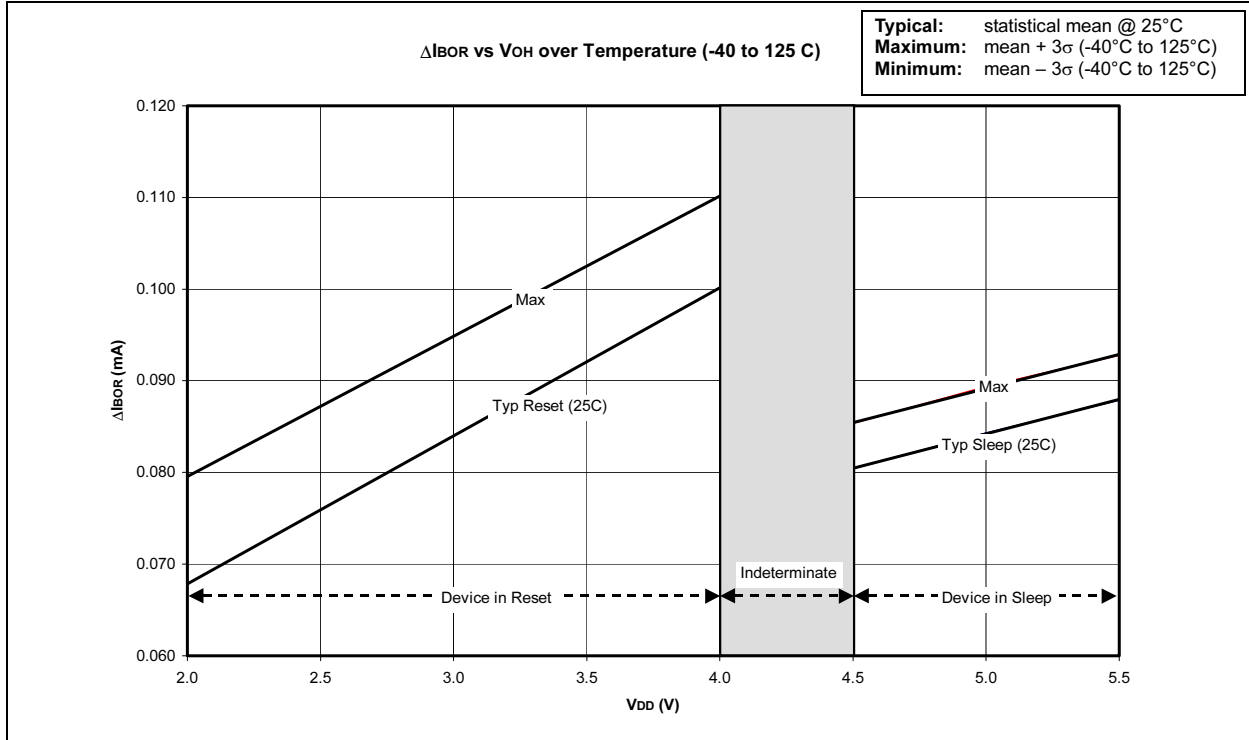

FIGURE 18-11: ΔI_{BOD} vs V_{OH} OVER TEMPERATURE (-40 to 125°C)



Note: The graphs and tables provided in this section are for design guidance and are not tested.

**FIGURE 18-12: $\Delta I_{TMR1OSC}$ vs V_{DD} OVER TEMP (0C to +70°C)
SLEEP MODE, TIMER1 OSCILLATOR, 32 kHz XTAL**

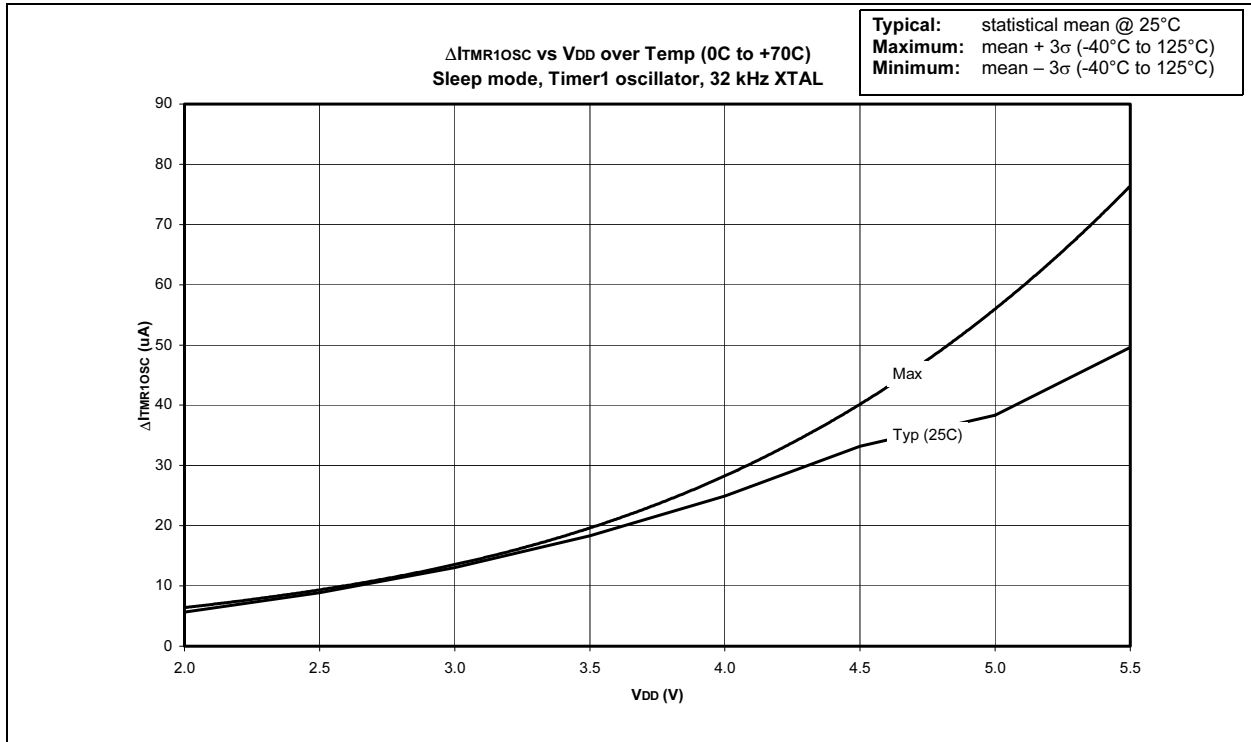
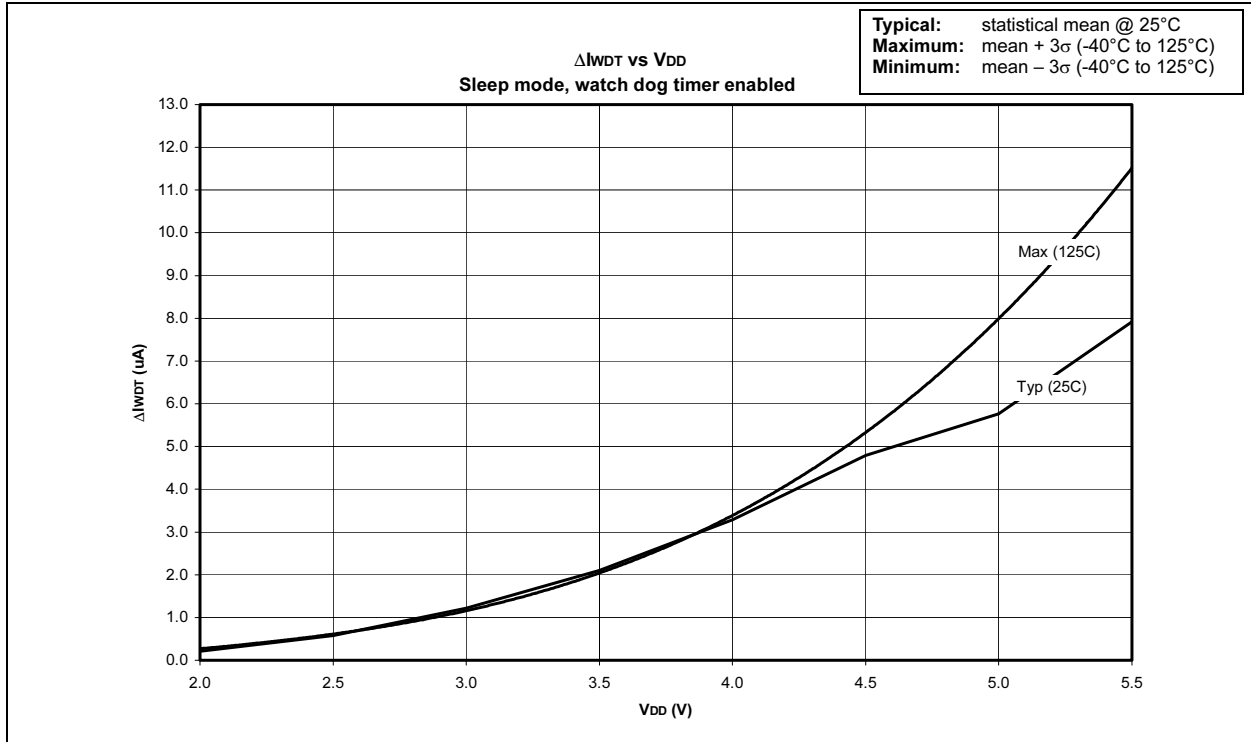

FIGURE 18-13: ΔI_{WDT} vs V_{DD} SLEEP MODE, WATCH DOG TIMER ENABLED



PIC16F62X

Note: The graphs and tables provided in this section are for design guidance and are not tested.

FIGURE 18-14: ΔI_{COMP} vs V_{DD} SLEEP MODE, COMPARATORS ENABLED

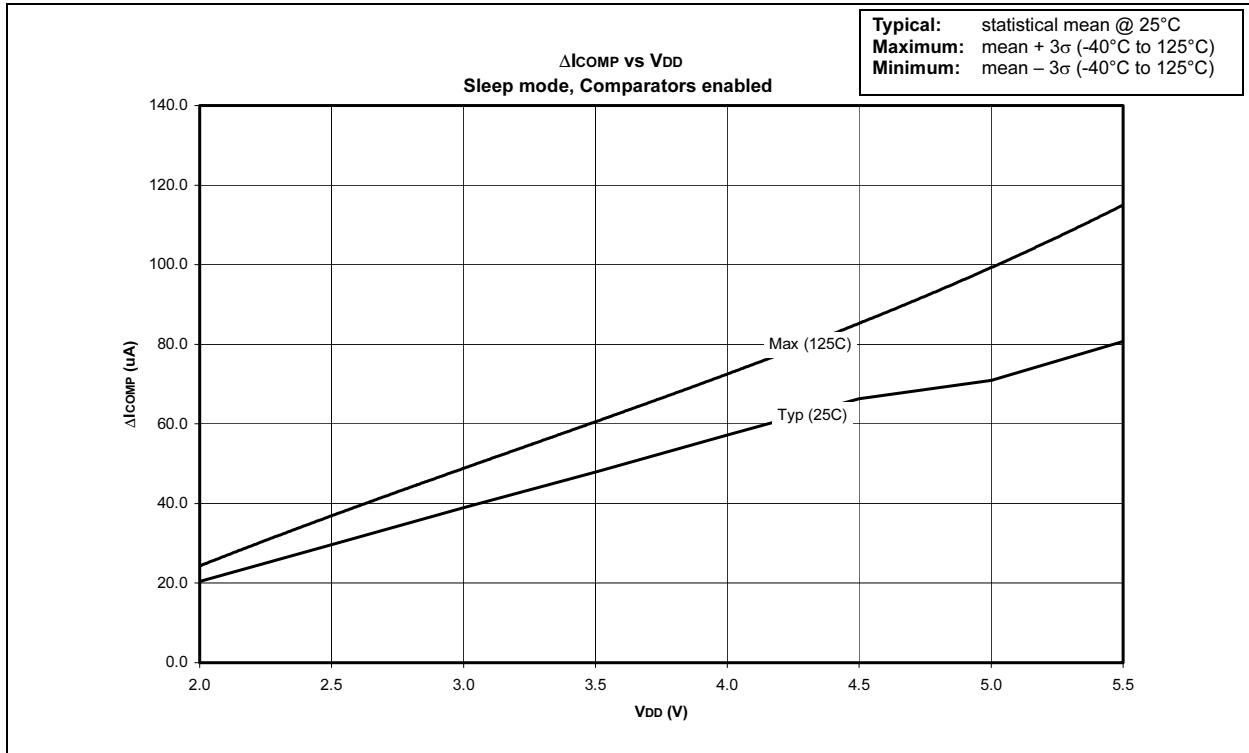
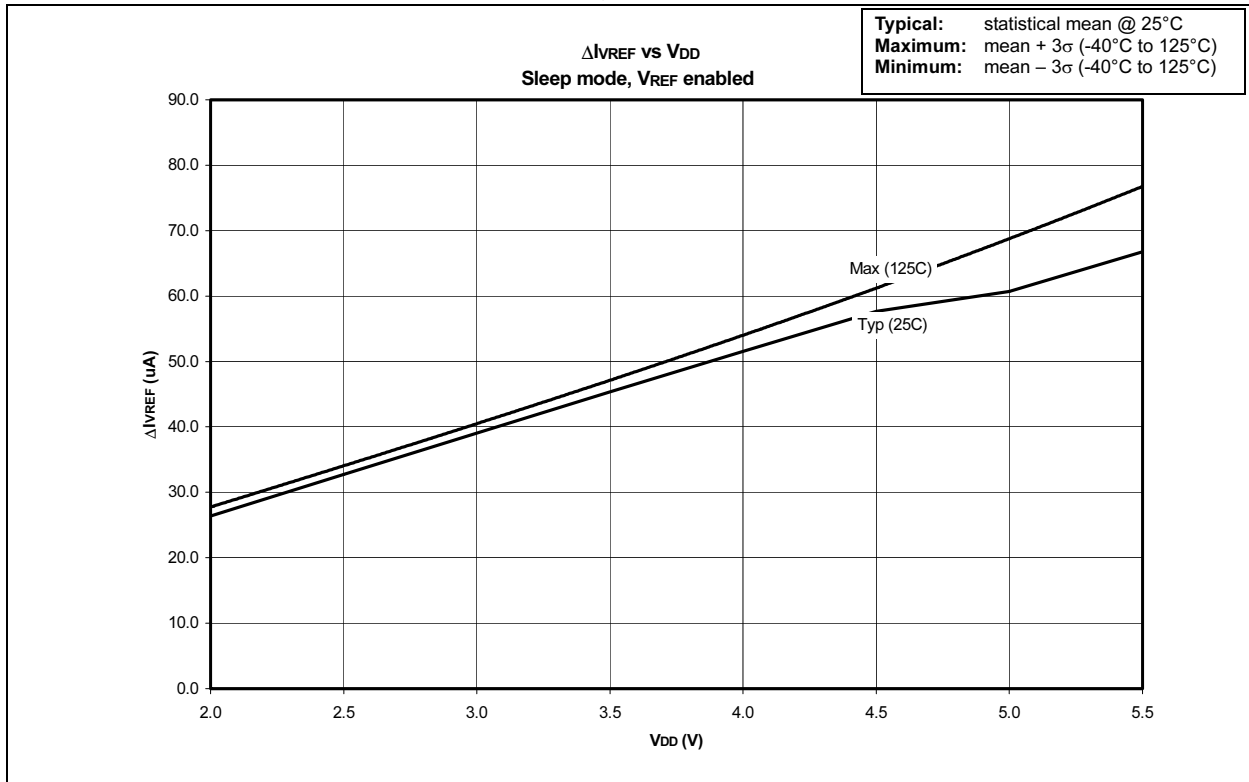

FIGURE 18-15: ΔI_{VREF} vs V_{DD} SLEEP MODE, V_{REF} ENABLED



Note: The graphs and tables provided in this section are for design guidance and are not tested.

FIGURE 18-16: MINIMUM, TYPICAL and MAXIMUM WDT PERIOD vs VDD (-40°C to +125°C)

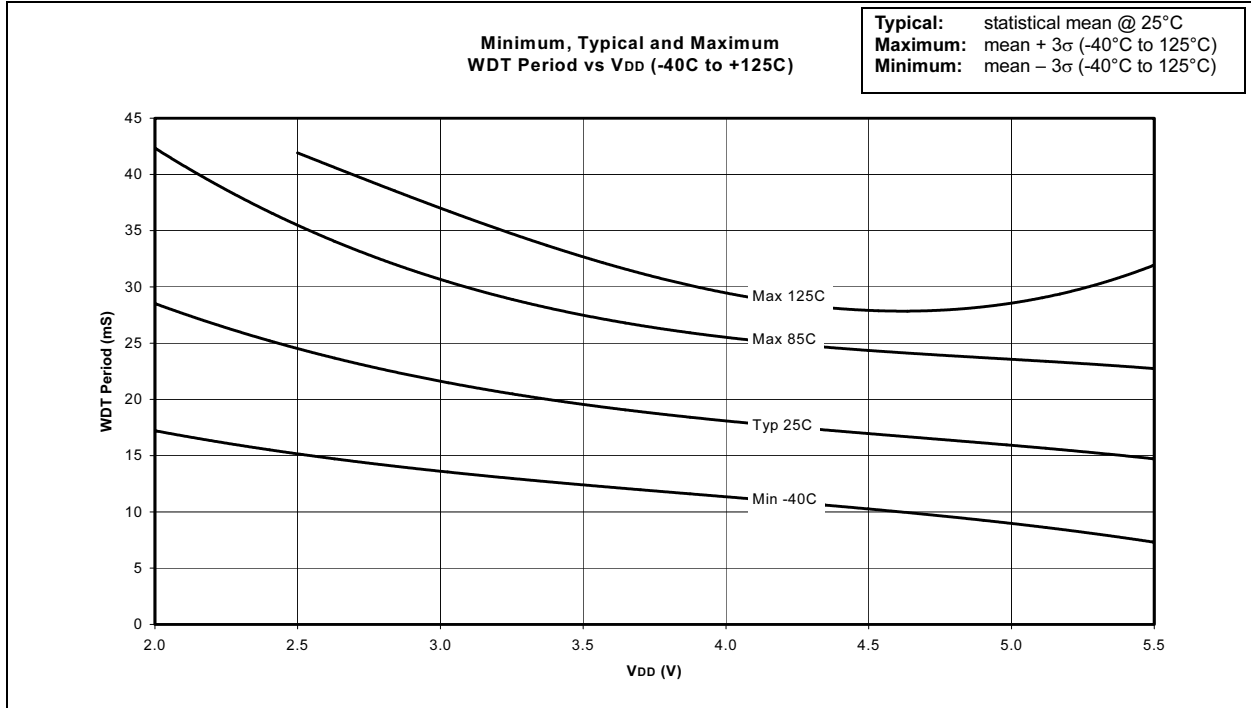
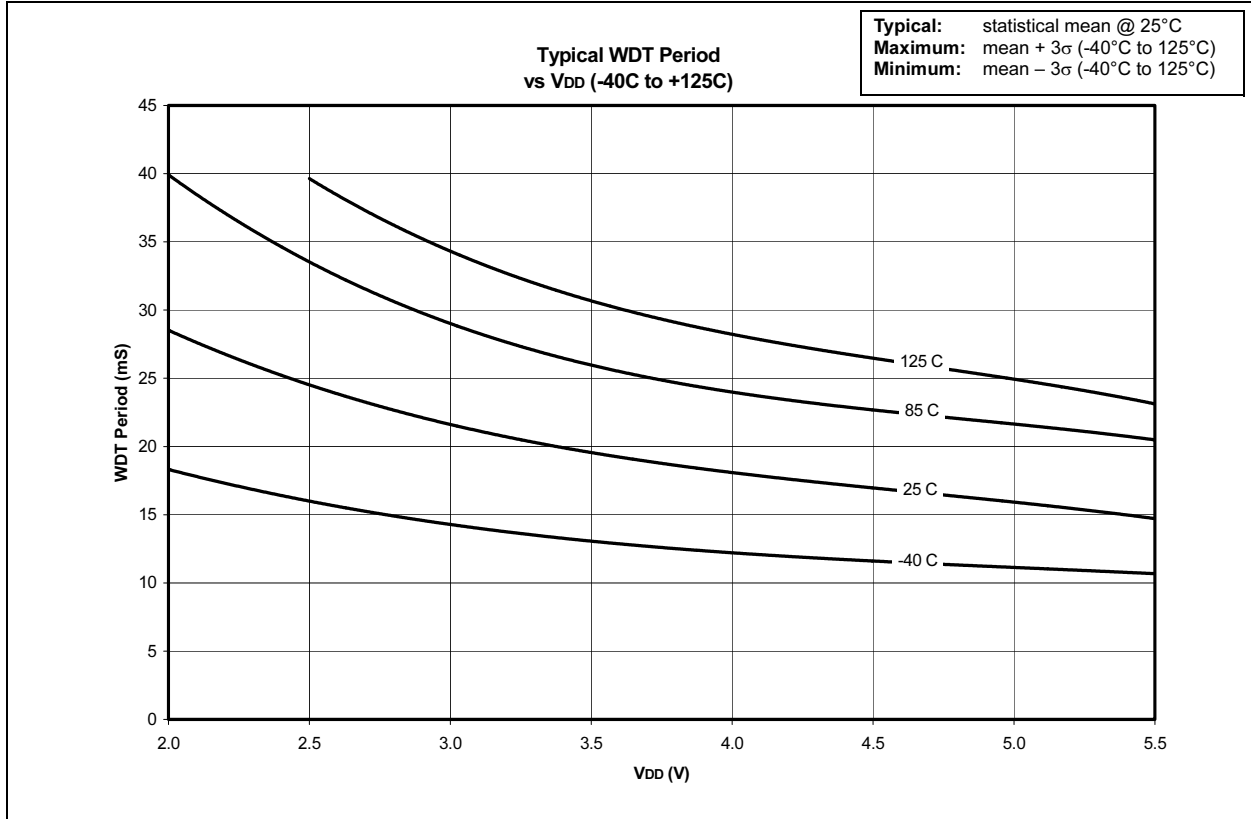

FIGURE 18-17: TYPICAL WDT PERIOD vs VDD (-40°C to +125°C)



PIC16F62X

Note: The graphs and tables provided in this section are for design guidance and are not tested.

FIGURE 18-18: V_{OH} vs I_{OH} OVER TEMP (C) $V_{DD} = 5V$

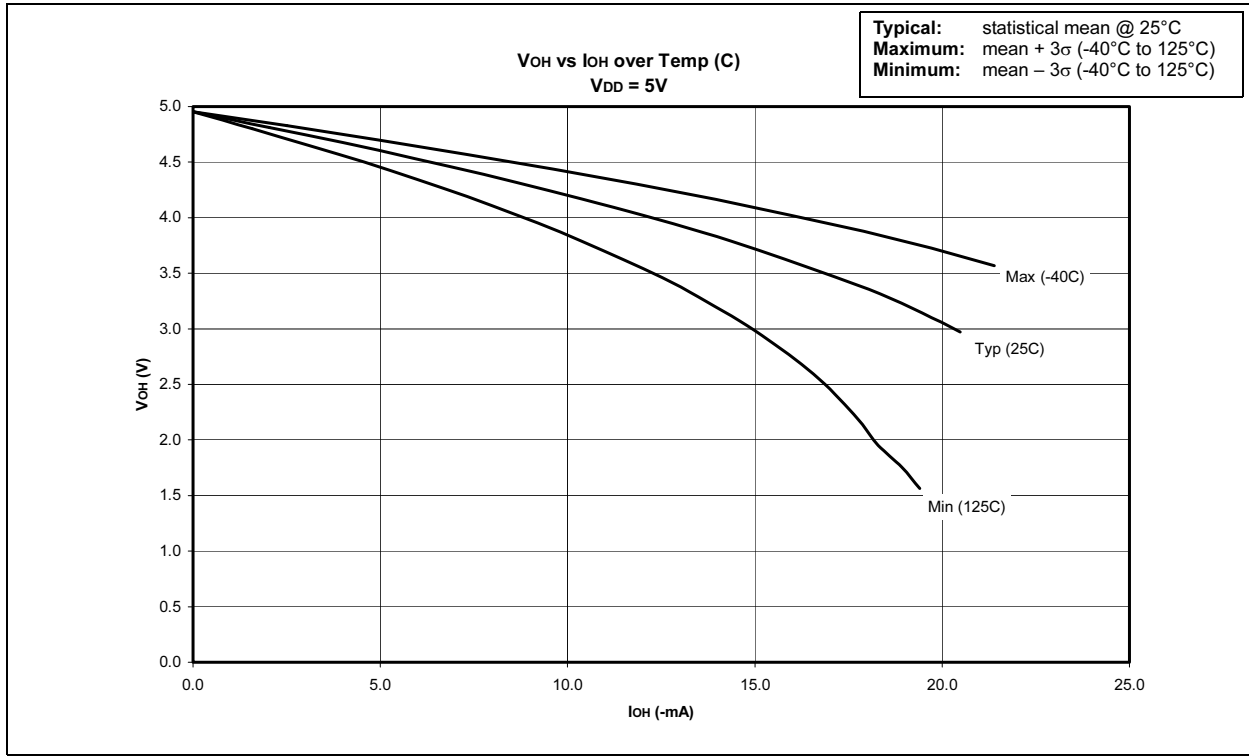
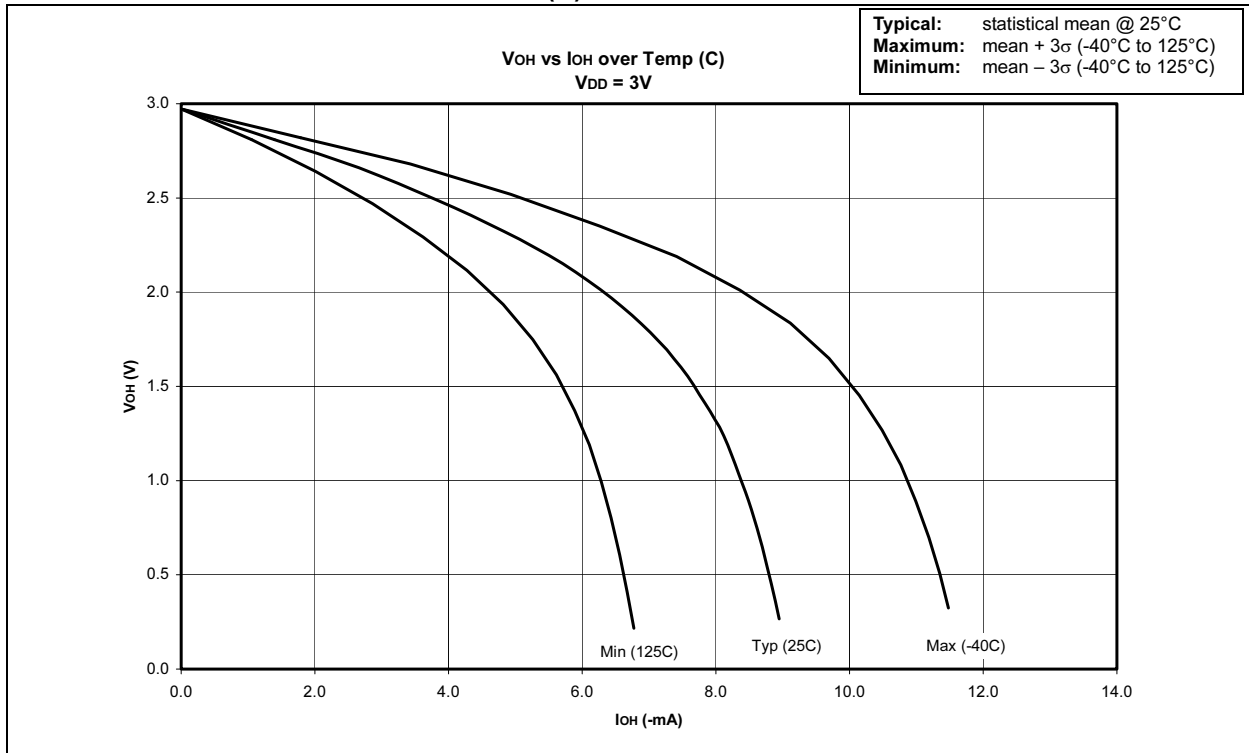

FIGURE 18-19: V_{OH} vs I_{OH} OVER TEMP (C) $V_{DD} = 3V$



Note: The graphs and tables provided in this section are for design guidance and are not tested.

FIGURE 18-20: VOL vs IOL OVER TEMP (C) VDD = 5V

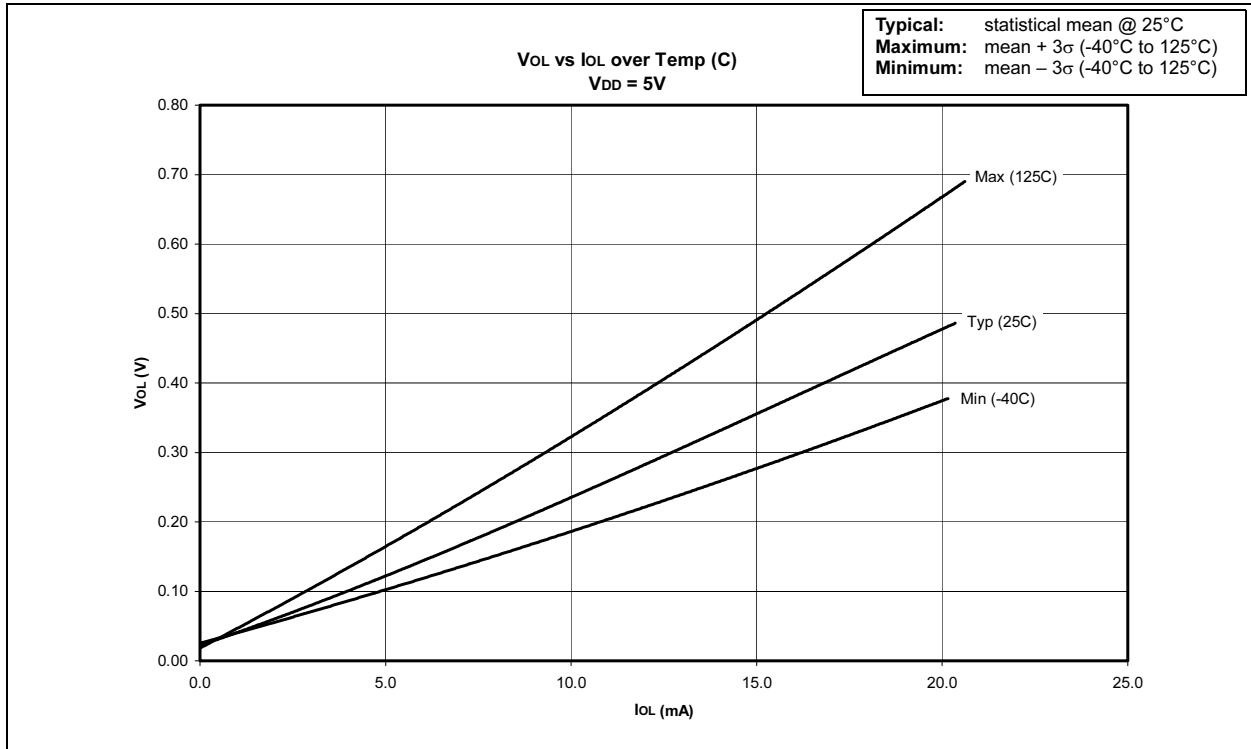
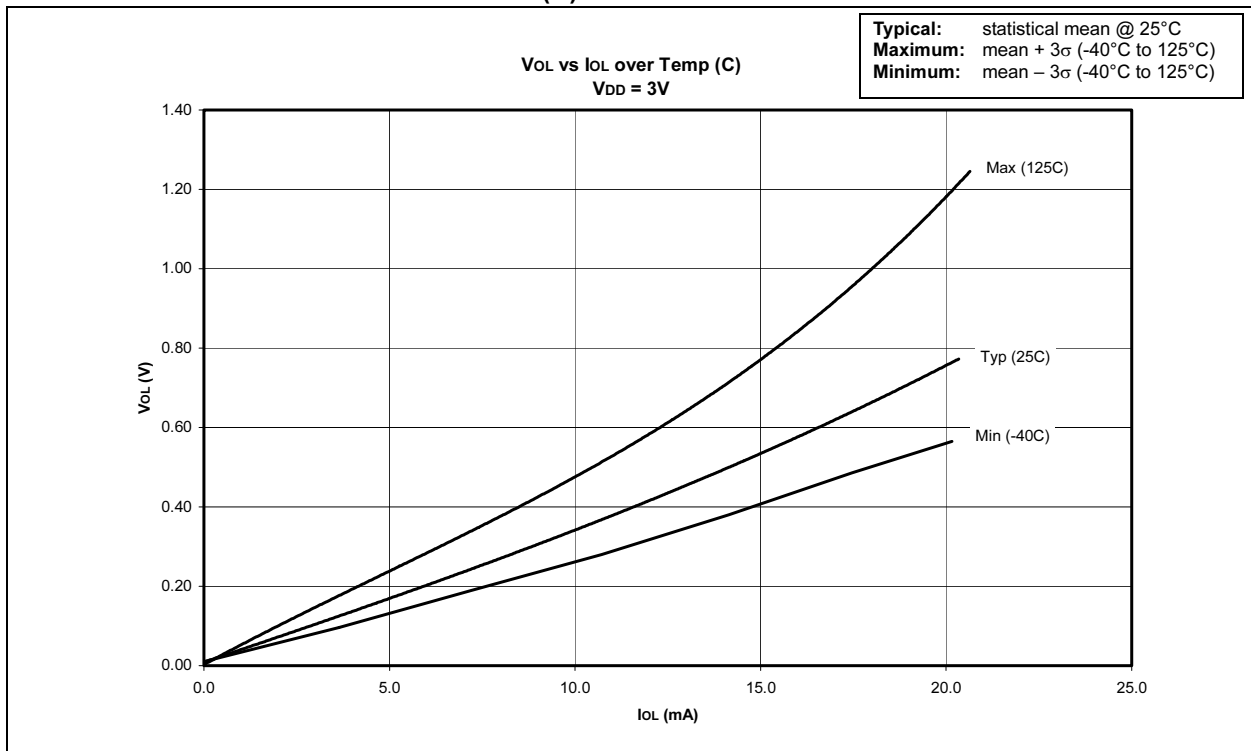

FIGURE 18-21: VOL vs IOL OVER TEMP (C) VDD = 3V



PIC16F62X

Note: The graphs and tables provided in this section are for design guidance and are not tested.

FIGURE 18-22: VIN vs VDD TTL

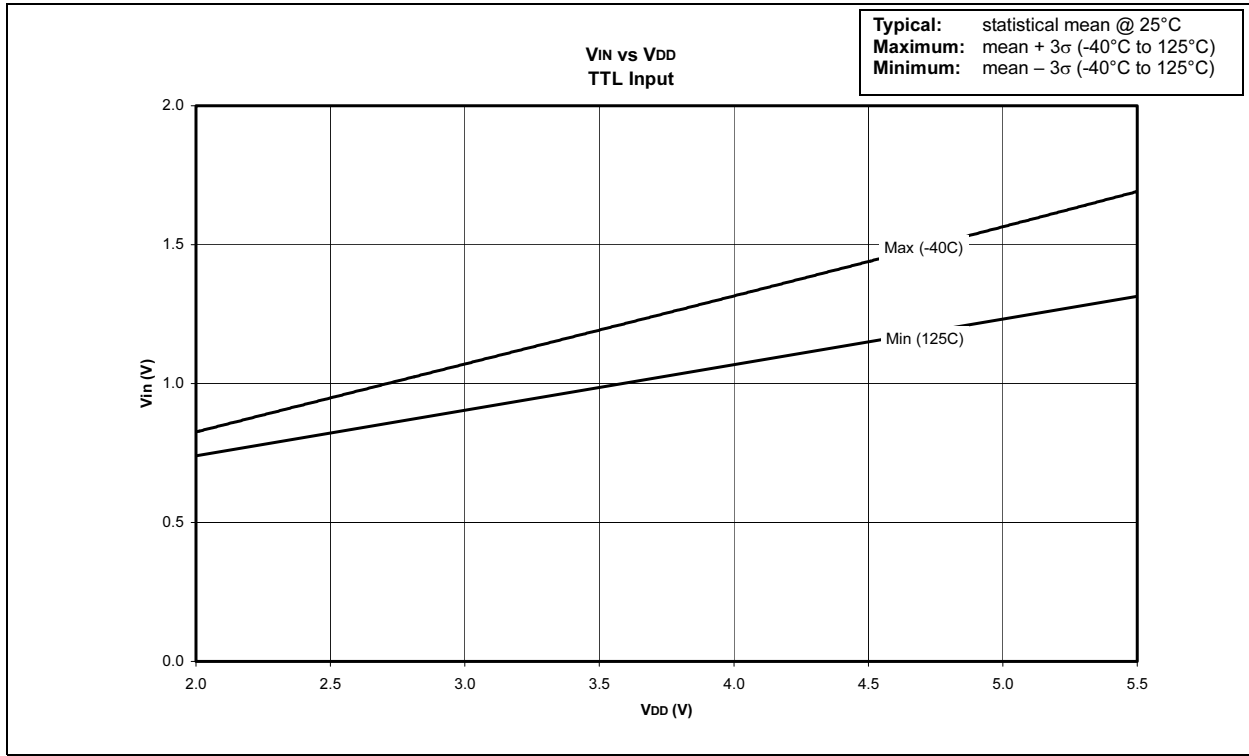
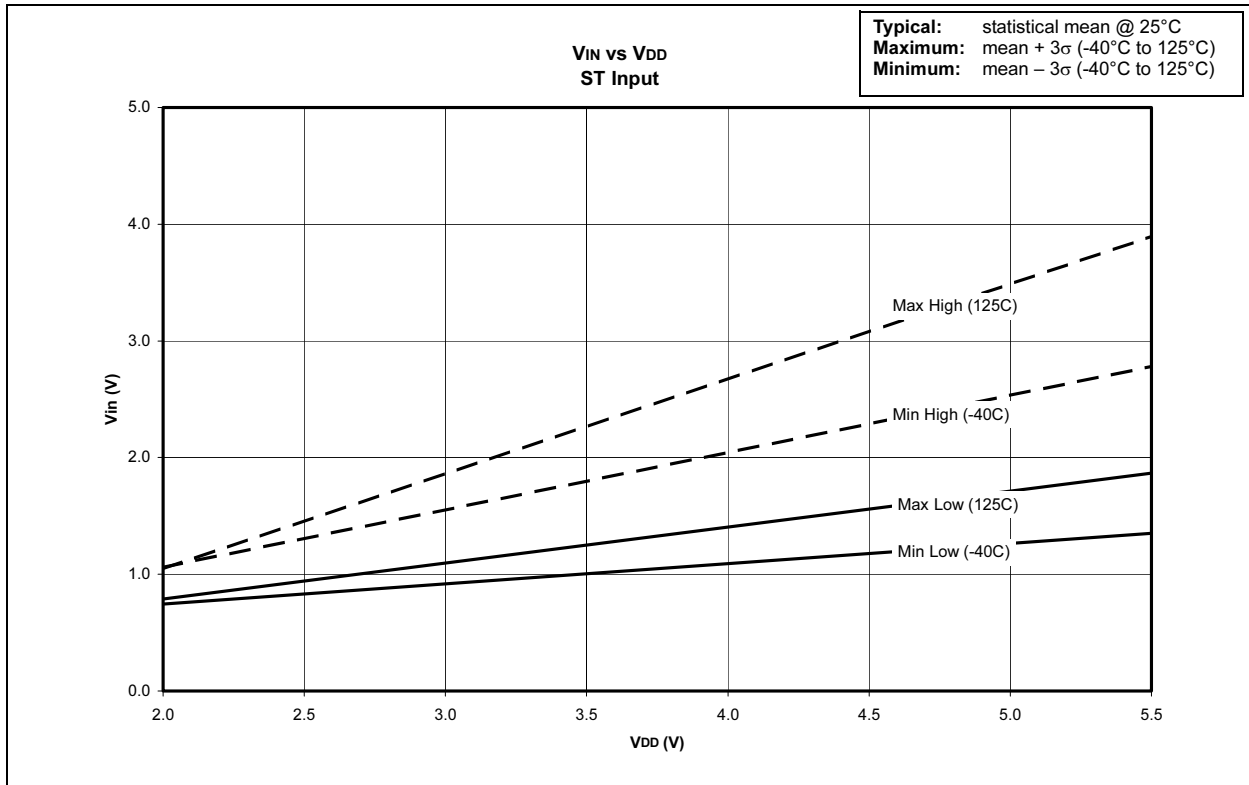

FIGURE 18-23: VIN vs VDD ST INPUT



Note: The graphs and tables provided in this section are for design guidance and are not tested.

FIGURE 18-24: MAXIMUM I_{DD} VS V_{DD} OVER TEMPERATURE (-40 TO +125°C) INTERNAL 37 kHz OSCILLATOR

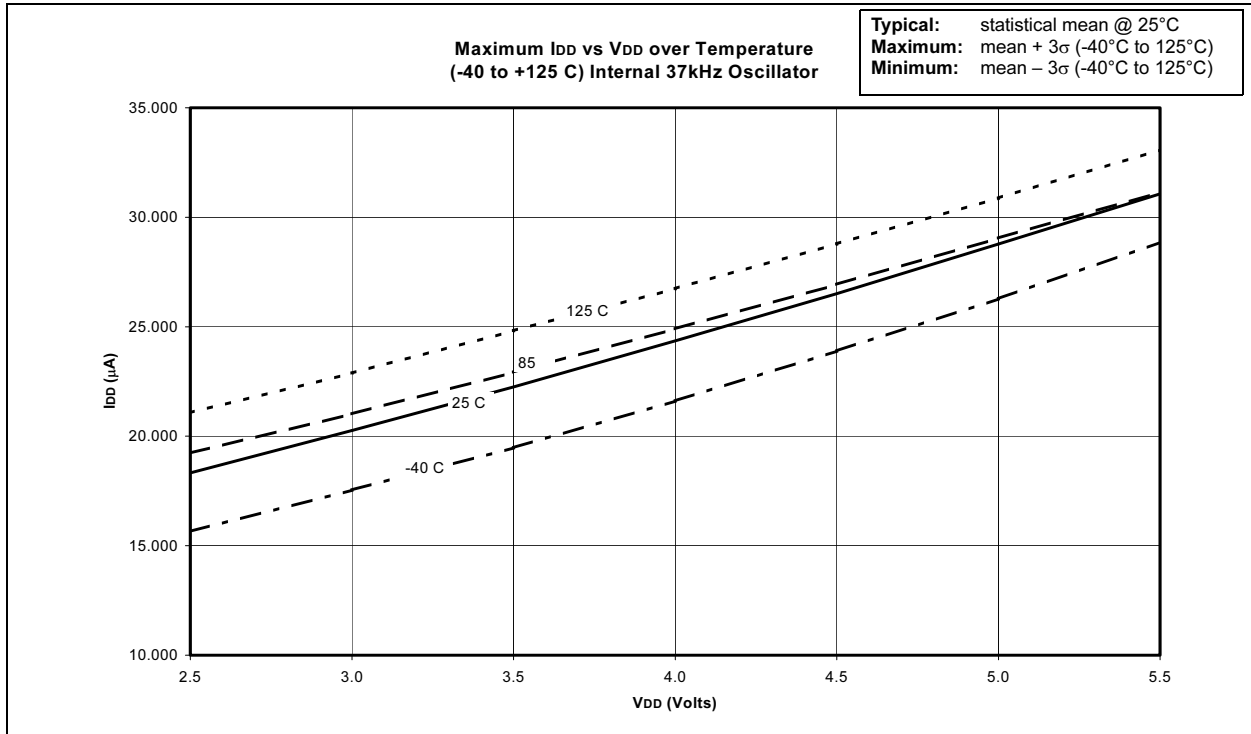
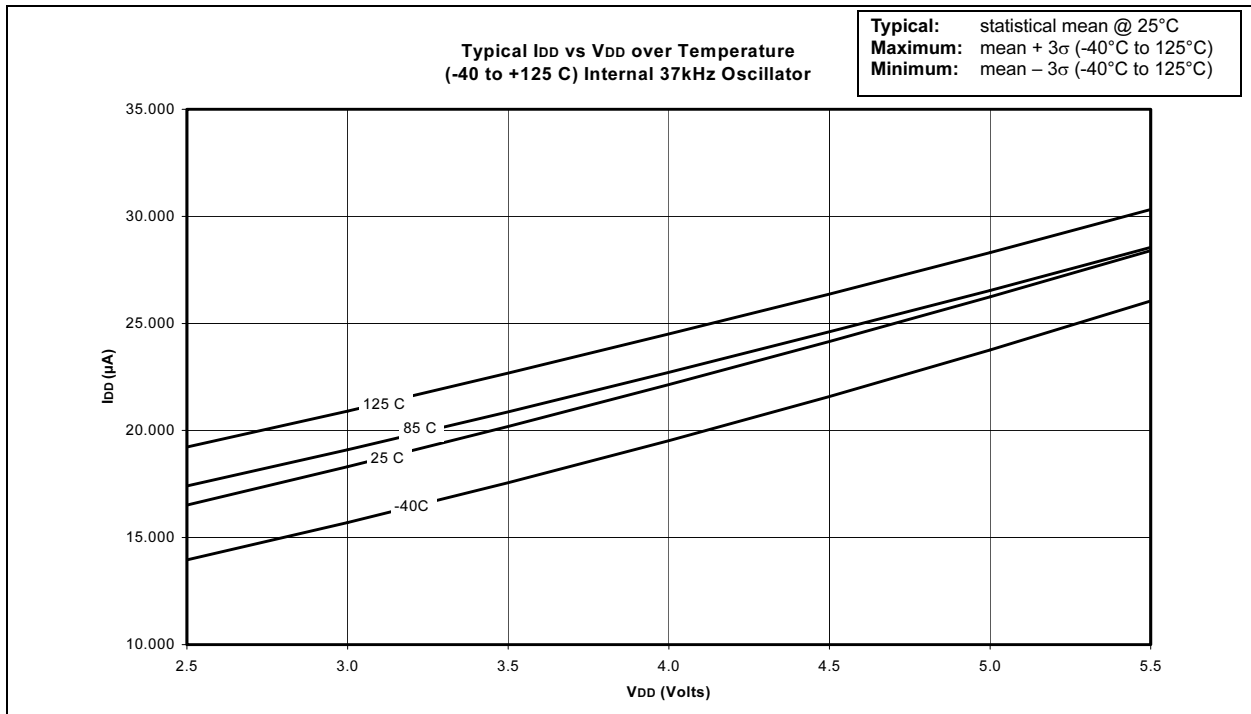

FIGURE 18-25: TYPICAL I_{DD} VS V_{DD} OVER TEMPERATURE (-40 TO +125°C) INTERNAL 37 kHz OSCILLATOR



PIC16F62X

Note: The graphs and tables provided in this section are for design guidance and are not tested.

FIGURE 18-26: MAXIMUM I_{DD} vs V_{DD} OVER TEMPERATURE (-40 TO +125°C) INTERNAL 4 MHz OSCILLATOR

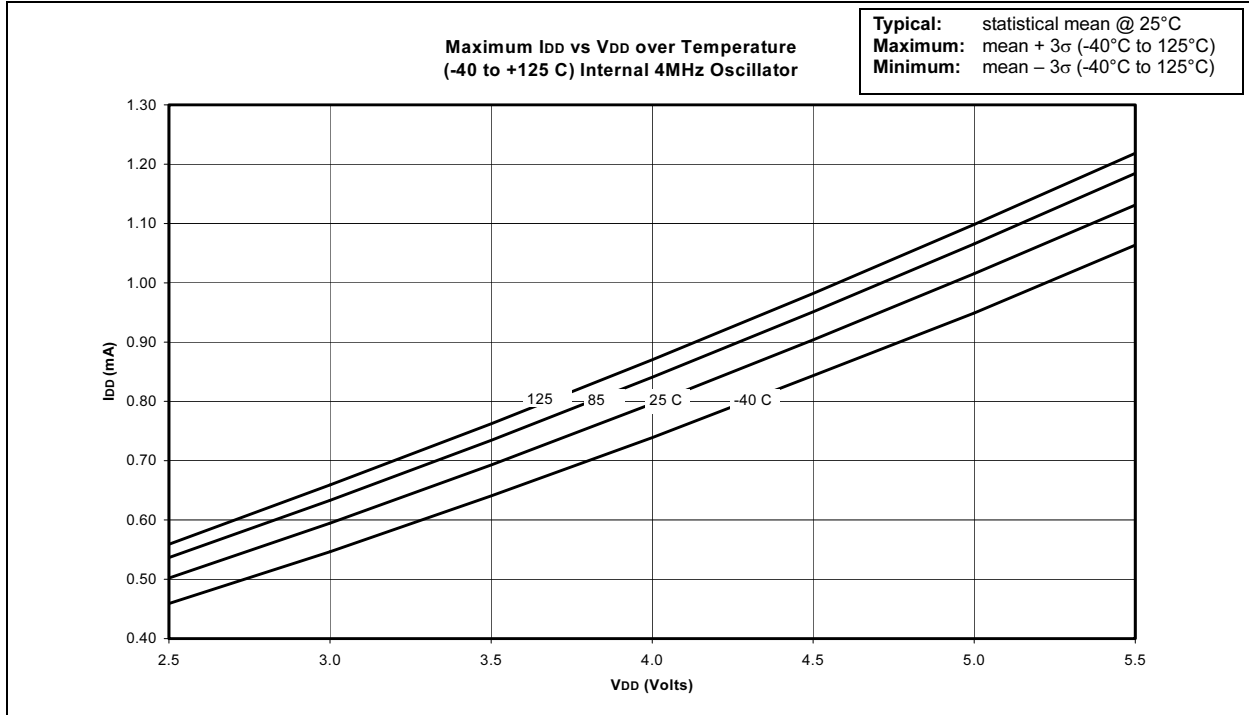
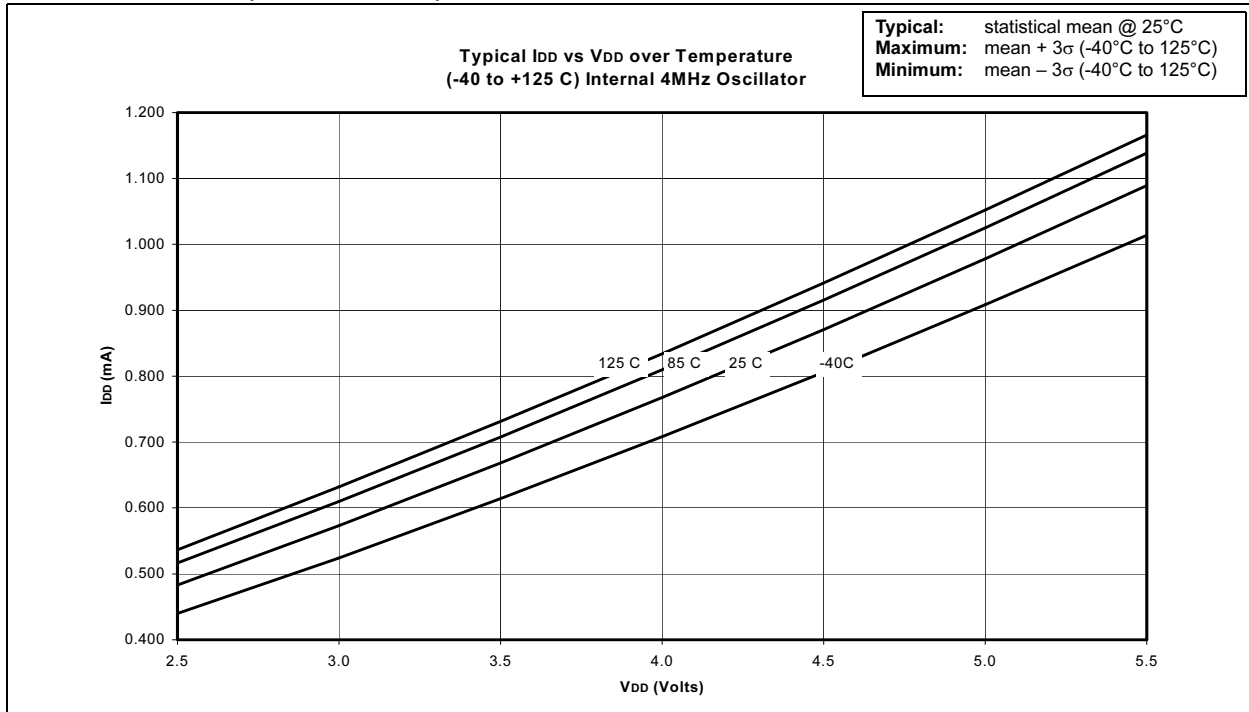

FIGURE 18-27: TYPICAL I_{DD} vs V_{DD} OVER TEMPERATURE (-40 TO +125°C) INTERNAL 4 MHz OSCILLATOR



19.0 PACKAGING INFORMATION

19.1 Package Marking Information

18-LEAD PDIP

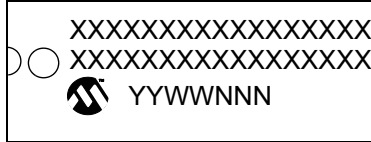

EXAMPLE



18-LEAD SOIC (.300")

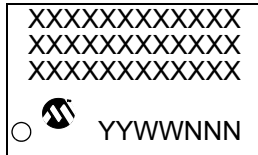

EXAMPLE



20-LEAD SSOP

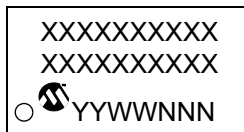

EXAMPLE



Legend: MM...M	Microchip part number information
XX...X	Customer specific information(1)
YY	Year code (last 2 digits of calendar year)
WW	Week code (week of January 1 is week '01')
NNN	Alphanumeric traceability code

Note: In the event the full Microchip part number cannot be marked on one line, it will be carried over to the next line thus limiting the number of available characters for customer specific information.

* Standard OTP marking consists of Microchip part number, year code, week code, facility code, mask rev#, and assembly code. For OTP marking beyond this, certain price adders apply. Please check with your Microchip Sales Office. For QTP devices, any special marking adders are included in QTP price.

PIC16F62X

K04-007 18-Lead Plastic Dual In-line (P) – 300 mil

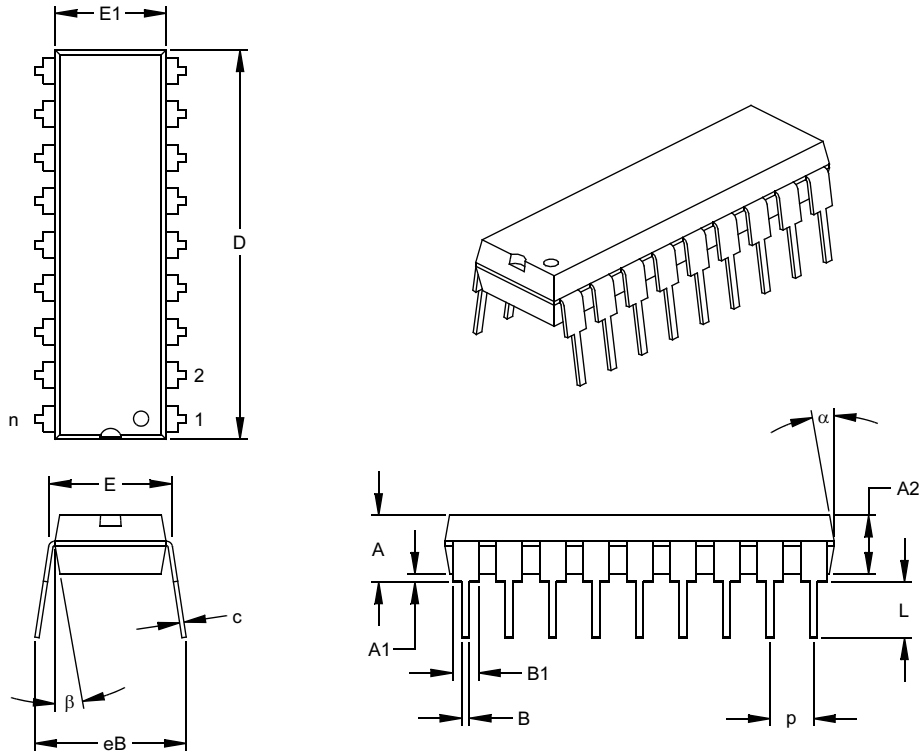

Dimension Limits		Units	INCHES*			MILLIMETERS		
			MIN	NOM	MAX	MIN	NOM	MAX
Number of Pins	n			18			18	
Pitch	p			.100			2.54	
Top to Seating Plane	A		.140	.155	.170	3.56	3.94	4.32
Molded Package Thickness	A2		.115	.130	.145	2.92	3.30	3.68
Base to Seating Plane	A1		.015			0.38		
Shoulder to Shoulder Width	E		.300	.313	.325	7.62	7.94	8.26
Molded Package Width	E1		.240	.250	.260	6.10	6.35	6.60
Overall Length	D		.890	.898	.905	22.61	22.80	22.99
Tip to Seating Plane	L		.125	.130	.135	3.18	3.30	3.43
Lead Thickness	c		.008	.012	.015	0.20	0.29	0.38
Upper Lead Width	B1		.045	.058	.070	1.14	1.46	1.78
Lower Lead Width	B		.014	.018	.022	0.36	0.46	0.56
Overall Row Spacing	§ eB		.310	.370	.430	7.87	9.40	10.92
Mold Draft Angle Top	α		5	10	15	5	10	15
Mold Draft Angle Bottom	β		5	10	15	5	10	15

* Controlling Parameter

§ Significant Characteristic

Notes:

Dimensions D and E1 do not include mold flash or protrusions. Mold flash or protrusions shall not exceed .010" (0.254mm) per side.

JEDEC Equivalent: MS-001

Drawing No. C04-007

K04-051 18-Lead Plastic Small Outline (SO) – Wide, 300 mil

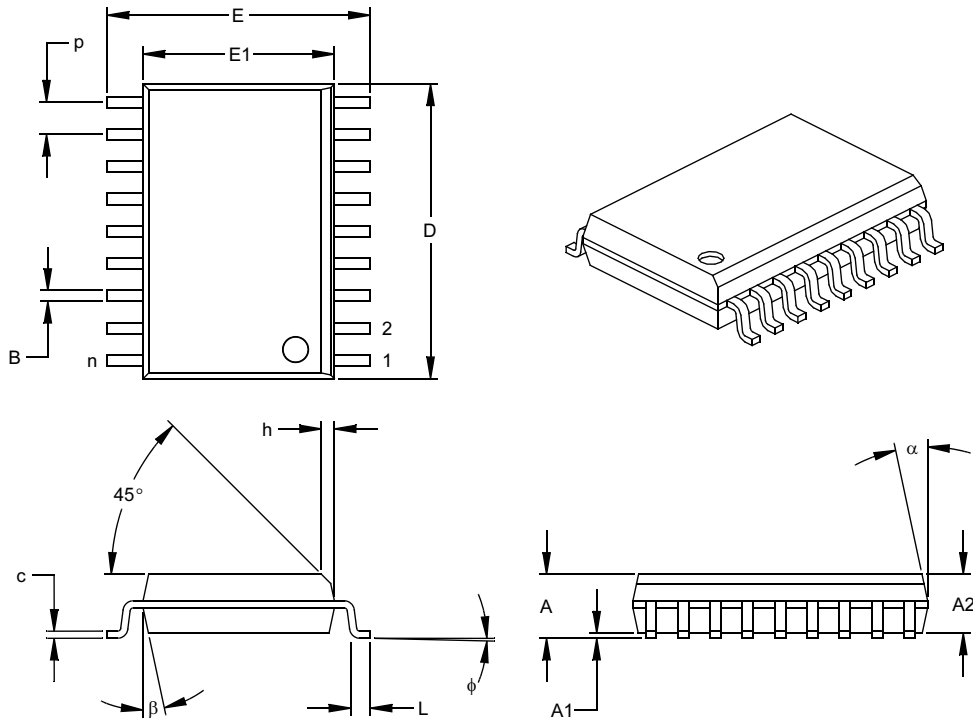

Units		INCHES*			MILLIMETERS		
Dimension Limits		MIN	NOM	MAX	MIN	NOM	MAX
Number of Pins	n		18			18	
Pitch	p		.050			1.27	
Overall Height	A	.093	.099	.104	2.36	2.50	2.64
Molded Package Thickness	A2	.088	.091	.094	2.24	2.31	2.39
Standoff §	A1	.004	.008	.012	0.10	0.20	0.30
Overall Width	E	.394	.407	.420	10.01	10.34	10.67
Molded Package Width	E1	.291	.295	.299	7.39	7.49	7.59
Overall Length	D	.446	.454	.462	11.33	11.53	11.73
Chamfer Distance	h	.010	.020	.029	0.25	0.50	0.74
Foot Length	L	.016	.033	.050	0.41	0.84	1.27
Foot Angle	φ	0	4	8	0	4	8
Lead Thickness	c	.009	.011	.012	0.23	0.27	0.30
Lead Width	B	.014	.017	.020	0.36	0.42	0.51
Mold Draft Angle Top	α	0	12	15	0	12	15
Mold Draft Angle Bottom	β	0	12	15	0	12	15

* Controlling Parameter

§ Significant Characteristic

Notes:

Dimensions D and E1 do not include mold flash or protrusions. Mold flash or protrusions shall not exceed .010" (0.254mm) per side.

JEDEC Equivalent: MS-013

Drawing No. C04-051

PIC16F62X

K04-072 20-Lead Plastic Shrink Small Outline (SS) – 5.30 mm

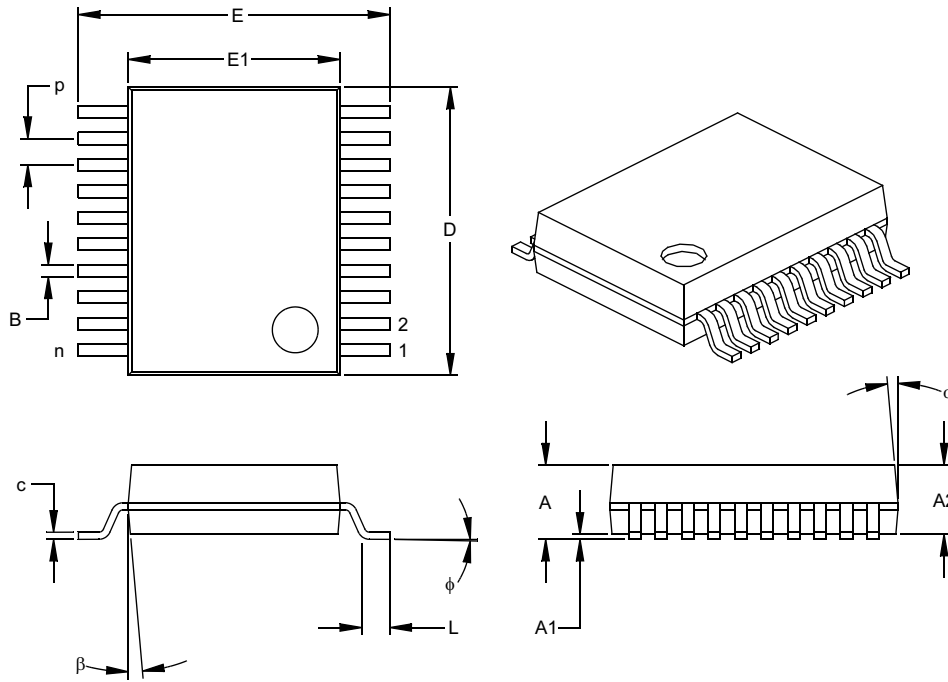

Units		INCHES*			MILLIMETERS		
Dimension	Limits	MIN	NOM	MAX	MIN	NOM	MAX
Number of Pins	n		20			20	
Pitch	p		.026			0.65	
Overall Height	A	.068	.073	.078	1.73	1.85	1.98
Molded Package Thickness	A2	.064	.068	.072	1.63	1.73	1.83
Standoff §	A1	.002	.006	.010	0.05	0.15	0.25
Overall Width	E	.299	.309	.322	7.59	7.85	8.18
Molded Package Width	E1	.201	.207	.212	5.11	5.25	5.38
Overall Length	D	.278	.284	.289	7.06	7.20	7.34
Foot Length	L	.022	.030	.037	0.56	0.75	0.94
Lead Thickness	c	.004	.007	.010	0.10	0.18	0.25
Foot Angle	φ	0	4	8	0.00	101.60	203.20
Lead Width	B	.010	.013	.015	0.25	0.32	0.38
Mold Draft Angle Top	α	0	5	10	0	5	10
Mold Draft Angle Bottom	β	0	5	10	0	5	10

* Controlling Parameter

§ Significant Characteristic

Notes:

Dimensions D and E1 do not include mold flash or protrusions. Mold flash or protrusions shall not exceed .010" (0.254mm) per side.

JEDEC Equivalent: MO-150

Drawing No. C04-072

INDEX

A

A/D	
Special Event Trigger (CCP)	63
Absolute Maximum Ratings	127
ADDLW Instruction	109
ADDWF Instruction	109
ANDLW Instruction	109
ANDWF Instruction	109
Architectural Overview	7
Assembler	
MPASM Assembler	121

B

Baud Rate Error	69
Baud Rate Formula	69
BCF Instruction	110
Block Diagram	
TMR0/WDT PRESCALER	44
Block Diagrams	
Comparator I/O Operating Modes	54
Comparator Output	56
RA3:RA0 and RA5 Port Pins	35
Timer1	47
Timer2	50
USART Receive	77
USART Transmit	75
BRGH bit	69
Brown-Out Detect (BOD)	96
BSF Instruction	110
BTFSC Instruction	110
BTFSS Instruction	111

C

CALL Instruction	111
Capture (CCP Module)	62
Block Diagram	62
CCP Pin Configuration	62
CCPR1H:CCPR1L Registers	62
Changing Between Capture Prescalers	62
Software Interrupt	62
Timer1 Mode Selection	62
Capture/Compare/PWM (CCP)	61
Capture Mode. See Capture	
CCP1	61
CCPR1H Register	61
CCPR1L Register	61
CCP2	61
Compare Mode. See Compare	
PWM Mode. See PWM	
Timer Resources	61
CCP1CON Register	
CCP1M3:CCP1M0 Bits	61
CCP1X:CCP1Y Bits	61
CCP2CON Register	
CCP2M3:CCP2M0 Bits	61
CCP2X:CCP2Y Bits	61
Clocking Scheme/Instruction Cycle	11
CLRF Instruction	111
CLRWF Instruction	112
CLRWDW Instruction	112
Code Protection	105
COMF Instruction	112
Comparator Configuration	54

Comparator Interrupts	57
Comparator Module	53
Comparator Operation	55
Comparator Reference	55
Compare (CCP Module)	62
Block Diagram	62
CCP Pin Configuration	62
CCPR1H:CCPR1L Registers	62
Software Interrupt	63
Special Event Trigger	63
Timer1 Mode Selection	63
Configuration Bits	91
Configuring the Voltage Reference	59
Crystal Operation	93

D

DATA	89
Data	88
Data EEPROM Memory	87
EECON1 Register	87
EECON2 Register	87
Data Memory Organization	13
DECWF Instruction	112
DECFSZ Instruction	113
Development Support	121

E

Errata	3
External Crystal Oscillator Circuit	93

G

General purpose Register File	13
GOTO Instruction	113

I

I/O Ports	29
I/O Programming Considerations	42
ID Locations	105
INCF Instruction	114
INCFSZ Instruction	114
In-Circuit Serial Programming	106
Indirect Addressing, INDF and FSR Registers	25
Instruction Flow/Pipelining	11
Instruction Set	
ADDLW	109
ADDWF	109
ANDLW	109
ANDWF	109
BCF	110
BSF	110
BTFSC	110
BTFSS	111
CALL	111
CLRF	111
CLRWF	112
CLRWDW	112
COMF	112
DECWF	112
DECFSZ	113
GOTO	113
INCF	114
INCFSZ	114
IORLW	115
IORWF	115
MOVWF	115

PIC16F62X

MOVLW	115	Pin Functions	
MOVWF	116	RC6/TX/CK	67–84
NOP	116	RC7/RX/DT	67–84
OPTION	116	PIR1	23
RETFIE	116	PIR1 Register	23
RETLW	117	Port RB Interrupt	102
RETURN	117	PORTA	29
RLF	117	PORTB	34
RRF	118	Power Control/Status Register (PCON)	97
SLEEP	118	Power-Down Mode (SLEEP)	104
SUBLW	118	Power-On Reset (POR)	96
SUBWF	119	Power-up Timer (PWRT)	96
SWAPF	119	PR2 Register	50
TRIS	119	Prescaler	44
XORLW	120	Prescaler, Capture	62
XORWF	120	Prescaler, Timer2	65
Instruction Set Summary	107	PRO MATE II Universal Device Programmer	123
INT Interrupt	102	Program Memory Organization	13
INTCON Register	21	PROTECTION	89
Interrupt Sources		PWM (CCP Module)	64
Capture Complete (CCP)	62	Block Diagram	64
Compare Complete (CCP)	63	CCPR1H:CCPR1L Registers	64
TMR2 to PR2 Match (PWM)	64	Duty Cycle	65
Interrupts	101	Example Frequencies/Resolutions	65
Interrupts, Enable Bits		Output Diagram	64
CCP1 Enable (CCP1IE Bit)	62	Period	64
Interrupts, Flag Bits		Set-Up for PWM Operation	65
CCP1 Flag (CCP1IF Bit)	62	TMR2 to PR2 Match	64
IORLW Instruction	115	Q	
IORWF Instruction	115	Q-Clock	65
M		Quick-Turnaround-Production (QTP) Devices	5
Memory Organization		R	
Data EEPROM Memory	87	RC Oscillator	94
MOVF Instruction	115	Registers	
MOVLW Instruction	115	Maps	
MOVWF Instruction	116	PIC16C76	14
MPLAB C17 and MPLAB C18 C Compilers	122	PIC16C77	14
MPLAB ICD In-Circuit Debugger	123	Reset	95
MPLAB ICE High Performance Universal In-Circuit Emulator with MPLAB IDE	123	RETFIE Instruction	116
MPLAB Integrated Development Environment Software ..	121	RETLW Instruction	117
MPLINK Object Linker/MPLIB Object Librarian	122	RETURN Instruction	117
N		RLF Instruction	117
NOP Instruction	116	RRF Instruction	118
O		S	
OPTION Instruction	116	Serial Communication Interface (SCI) Module, See USART	
OPTION Register	20	Serialized Quick-Turnaround-Production (SQTP) Devices ...	5
Oscillator Configurations	93	SLEEP Instruction	118
Oscillator Start-up Timer (OST)	96	Software Simulator (MPLAB SIM)	122
Output of TMR2	50	Special	95
P		Special Event Trigger. See Compare	
Package Marking Information	157	Special Features of the CPU	91
Packaging Information	157	Special Function Registers	15
PCL and PCLATH	25	Stack	25
PCON	24	Status Register	19
PCON Register	24	SUBLW Instruction	118
PICDEM 1 Low Cost PICmicro Demonstration Board	124	SUBWF Instruction	119
PICDEM 17 Demonstration Board	124	SWAPF Instruction	119
PICDEM 2 Low Cost PIC16CXX Demonstration Board	124	T	
PICSTART Plus Entry Level Development Programmer ..	123	T1CKPS0 bit	46
PIE1 Register	22	T1CKPS1 bit	46
		T1OSCEN bit	46

T1SYNC bit	46
T2CKPS0 bit	51
T2CKPS1 bit	51
Timer0	
TIMER0 (TMR0) Interrupt	43
TIMER0 (TMR0) Module	43
TMR0 with External Clock	43
Timer1	
Special Event Trigger (CCP)	63
Switching Prescaler Assignment	45
Timer2	
PR2 Register	64
TMR2 to PR2 Match Interrupt	64
Timers	
Timer1	
Asynchronous Counter Mode	48
Block Diagram	47
Capacitor Selection	49
External Clock Input	47
External Clock Input Timing	48
Operation in Timer Mode	47
Oscillator	49
Prescaler	47, 49
Resetting of Timer1 Registers	49
Resetting Timer1 using a CCP Trigger Output ...	49
Synchronized Counter Mode	47
TMR1H	48
TMR1L	48
Timer2	
Block Diagram	50
Module	50
Postscaler	50
Prescaler	50
Timing Diagrams	
Timer0	139
Timer1	139
USART Asynchronous Master Transmission	75
USART RX Pin Sampling	73, 74
USART Synchronous Reception	84
USART Synchronous Transmission	82
USART, Asynchronous Reception	78
Timing Diagrams and Specifications	135
TMR0 Interrupt	102
TMR1CS bit	46
TMR1ON bit	46
TMR2ON bit	51
TOUTPS0 bit	51
TOUTPS1 bit	51
TOUTPS2 bit	51
TOUTPS3 bit	51
TRIS Instruction	119
TRISA	29
TRISB	34
U	
Universal Synchronous Asynchronous Receiver Transmitter (USART)	67
Asynchronous Receiver	
Setting Up Reception	80
Timing Diagram	78
Asynchronous Receiver Mode	
Block Diagram	80
Section	80
USART	
Asynchronous Mode	74
Asynchronous Receiver	77

Asynchronous Reception	79
Asynchronous Transmission	75
Asynchronous Transmitter	74
Baud Rate Generator (BRG)	69
Sampling	70, 71, 72
Synchronous Master Mode	81
Synchronous Master Reception	83
Synchronous Master Transmission	81
Synchronous Slave Mode	84
Synchronous Slave Reception	85
Synchronous Slave Transmit	84
Transmit Block Diagram	75

V

Voltage Reference Module	59
--------------------------------	----

W

Watchdog Timer (WDT)	103
WRITE	89
WRITING	88
WWW, On-Line Support	3

X

XORLW Instruction	120
XORWF Instruction	120

PIC16F62X

NOTES:

ON-LINE SUPPORT

Microchip provides on-line support on the Microchip World Wide Web site.

The web site is used by Microchip as a means to make files and information easily available to customers. To view the site, the user must have access to the Internet and a web browser, such as Netscape® or Microsoft® Internet Explorer. Files are also available for FTP download from our FTP site.

Connecting to the Microchip Internet Web Site

The Microchip web site is available at the following URL:

www.microchip.com

The file transfer site is available by using an FTP service to connect to:

<ftp://ftp.microchip.com>

The web site and file transfer site provide a variety of services. Users may download files for the latest Development Tools, Data Sheets, Application Notes, User's Guides, Articles and Sample Programs. A variety of Microchip specific business information is also available, including listings of Microchip sales offices, distributors and factory representatives. Other data available for consideration is:

- Latest Microchip Press Releases
- Technical Support Section with Frequently Asked Questions
- Design Tips
- Device Errata
- Job Postings
- Microchip Consultant Program Member Listing
- Links to other useful web sites related to Microchip Products
- Conferences for products, Development Systems, technical information and more
- Listing of seminars and events

SYSTEMS INFORMATION AND UPGRADE HOT LINE

The Systems Information and Upgrade Line provides system users a listing of the latest versions of all of Microchip's development systems software products. Plus, this line provides information on how customers can receive the most current upgrade kits. The Hot Line Numbers are:

1-800-755-2345 for U.S. and most of Canada, and

1-480-792-7302 for the rest of the world.

092002

PIC16F62X

READER RESPONSE

It is our intention to provide you with the best documentation possible to ensure successful use of your Microchip product. If you wish to provide your comments on organization, clarity, subject matter, and ways in which our documentation can better serve you, please FAX your comments to the Technical Publications Manager at (480) 792-4150.

Please list the following information, and use this outline to provide us with your comments about this document.

To: Technical Publications Manager
RE: Reader Response
From: Name _____
Company _____
Address _____
City / State / ZIP / Country _____
Telephone: (_____) _____ - _____ FAX: (_____) _____ - _____

Application (optional):

Would you like a reply? ___Y ___N

Device: PIC16F62X Literature Number: DS40300C

Questions:

1. What are the best features of this document?

2. How does this document meet your hardware and software development needs?

3. Do you find the organization of this document easy to follow? If not, why?

4. What additions to the document do you think would enhance the structure and subject?

5. What deletions from the document could be made without affecting the overall usefulness?

6. Is there any incorrect or misleading information (what and where)?

7. How would you improve this document?

PRODUCT IDENTIFICATION SYSTEM

To order or obtain information, e.g., on pricing or delivery, refer to the factory or the listed sales office.

PART NO.	-XX	X	/XX	XXX	
Device	Frequency Range	Temperature Range	Package	Pattern	Examples:
Device	PIC16F62X: Standard VDD range 3.0V to 5.5V PIC16F62XT: VDD range 3.0V to 5.5V (Tape and Reel) PIC16LF62X: VDD range 2.0V to 5.5V PIC16LF62XT: VDD range 2.0V to 5.5V (Tape and Reel)				a) PIC16F627 - 04/P 301 = Commercial Temp., PDIP package, 4 MHz, normal VDD limits, QTP pattern #301.
Frequency Range	04 = 200 kHz (LP osc) 04 = 4 MHz (XT and ER osc) 20 = 20 MHz (HS osc)				b) PIC16LF627 - 04I/SO = Industrial Temp., SOIC package, 200 kHz, extended VDD limits.
Temperature Range	- = 0°C to +70°C I = -40°C to +85°C E = -40°C to +125°C				
Package	P = PDIP SO = SOIC (Gull Wing, 300 mil body) SS = SSOP (209 mil)				
Pattern	3-Digit Pattern Code for QTP (blank otherwise).				

* JW Devices are UV erasable and can be programmed to any device configuration. JW Devices meet the electrical requirement of each oscillator type.

Sales and Support

Data Sheets

Products supported by a preliminary Data Sheet may have an errata sheet describing minor operational differences and recommended workarounds. To determine if an errata sheet exists for a particular device, please contact one of the following:

1. Your local Microchip sales office
2. The Microchip Corporate Literature Center U.S. FAX: (480) 792-7277
3. The Microchip Worldwide Site (www.microchip.com)

Please specify which device, revision of silicon and Data Sheet (include Literature #) you are using.

New Customer Notification System

Register on our web site (www.microchip.com/cn) to receive the most current information on our products.



WORLDWIDE SALES AND SERVICE

AMERICAS

Corporate Office

2355 West Chandler Blvd.
Chandler, AZ 85224-6199
Tel: 480-792-7200 Fax: 480-792-7277
Technical Support: 480-792-7627
Web Address: <http://www.microchip.com>

Rocky Mountain

2355 West Chandler Blvd.
Chandler, AZ 85224-6199
Tel: 480-792-7966 Fax: 480-792-4338

Atlanta

3780 Mansell Road, Suite 130
Alpharetta, GA 30022
Tel: 770-640-0034 Fax: 770-640-0307

Boston

2 Lan Drive, Suite 120
Westford, MA 01886
Tel: 978-692-3848 Fax: 978-692-3821

Chicago

333 Pierce Road, Suite 180
Itasca, IL 60143
Tel: 630-285-0071 Fax: 630-285-0075

Dallas

4570 Westgrove Drive, Suite 160
Addison, TX 75001
Tel: 972-818-7423 Fax: 972-818-2924

Detroit

Tri-Atria Office Building
32255 Northwestern Highway, Suite 190
Farmington Hills, MI 48334
Tel: 248-538-2250 Fax: 248-538-2260

Kokomo

2767 S. Albright Road
Kokomo, Indiana 46902
Tel: 765-864-8360 Fax: 765-864-8387

Los Angeles

18201 Von Karman, Suite 1090
Irvine, CA 92612
Tel: 949-263-1888 Fax: 949-263-1338

San Jose

Microchip Technology Inc.
2107 North First Street, Suite 590
San Jose, CA 95131
Tel: 408-436-7950 Fax: 408-436-7955

Toronto

6285 Northam Drive, Suite 108
Mississauga, Ontario L4V 1X5, Canada
Tel: 905-673-0699 Fax: 905-673-6509

ASIA/PACIFIC

Australia

Microchip Technology Australia Pty Ltd
Suite 22, 41 Rawson Street
Epping 2121, NSW
Australia
Tel: 61-2-9868-6733 Fax: 61-2-9868-6755

China - Beijing

Microchip Technology Consulting (Shanghai)
Co., Ltd., Beijing Liaison Office
Unit 915
Bei Hai Wan Tai Bldg.
No. 6 Chaoyangmen Beidajie
Beijing, 100027, No. China
Tel: 86-10-85282100 Fax: 86-10-85282104

China - Chengdu

Microchip Technology Consulting (Shanghai)
Co., Ltd., Chengdu Liaison Office
Rm. 2401-2402, 24th Floor,
Ming Xing Financial Tower
No. 88 TIDU Street
Chengdu 610016, China
Tel: 86-28-86766200 Fax: 86-28-86766599

China - Fuzhou

Microchip Technology Consulting (Shanghai)
Co., Ltd., Fuzhou Liaison Office
Unit 28F, World Trade Plaza
No. 71 Wusi Road
Fuzhou 350001, China
Tel: 86-591-7503506 Fax: 86-591-7503521

China - Hong Kong SAR

Microchip Technology Hongkong Ltd.
Unit 901-6, Tower 2, Metroplaza
223 Hing Fong Road
Kwai Fong, N.T., Hong Kong
Tel: 852-2401-1200 Fax: 852-2401-3431

China - Shanghai

Microchip Technology Consulting (Shanghai)
Co., Ltd.
Room 701, Bldg. B
Far East International Plaza
No. 317 Xian Xia Road
Shanghai, 200051
Tel: 86-21-6275-5700 Fax: 86-21-6275-5060

China - Shenzhen

Microchip Technology Consulting (Shanghai)
Co., Ltd., Shenzhen Liaison Office
Rm. 1812, 18/F, Building A, United Plaza
No. 5022 Binhe Road, Futian District
Shenzhen 518033, China
Tel: 86-755-82901380 Fax: 86-755-82966626

China - Qingdao

Rm. B503, Fullhope Plaza,
No. 12 Hong Kong Central Rd.
Qingdao 266071, China
Tel: 86-532-5027355 Fax: 86-532-5027205

India

Microchip Technology Inc.
India Liaison Office
Divyasree Chambers
1 Floor, Wing A (A3/A4)
No. 11, O'Shaughnessey Road
Bangalore, 560 025, India
Tel: 91-80-2290061 Fax: 91-80-2290062

Japan

Microchip Technology Japan K.K.
Benex S-1 6F
3-18-20, Shinyokohama
Kohoku-Ku, Yokohama-shi
Kanagawa, 222-0033, Japan
Tel: 81-45-471-6166 Fax: 81-45-471-6122

Korea

Microchip Technology Korea
168-1, Youngbo Bldg. 3 Floor
Samsung-Dong, Kangnam-Ku
Seoul, Korea 135-882
Tel: 82-2-554-7200 Fax: 82-2-558-5934

Singapore

Microchip Technology Singapore Pte Ltd.
200 Middle Road
#07-02 Prime Centre
Singapore, 188980
Tel: 65-6334-8870 Fax: 65-6334-8850

Taiwan

Microchip Technology (Barbados) Inc.,
Taiwan Branch
11F-3, No. 207
Tung Hua North Road
Taipei, 105, Taiwan
Tel: 886-2-2717-7175 Fax: 886-2-2545-0139

EUROPE

Austria

Microchip Technology Austria GmbH
Durisolstrasse 2
A-4600 Wels
Austria
Tel: 43-7242-2244-399
Fax: 43-7242-2244-393

Denmark

Microchip Technology Nordic ApS
Regus Business Centre
Lautrup høj 1-3
Ballerup DK-2750 Denmark
Tel: 45 4420 9895 Fax: 45 4420 9910

France

Microchip Technology SARL
Parc d'Activite du Moulin de Massy
43 Rue du Saule Trapu
Batiment A - 1er Etage
91300 Massy, France
Tel: 33-1-69-53-63-20 Fax: 33-1-69-30-90-79

Germany

Microchip Technology GmbH
Steinheilstrasse 10
D-85737 Ismaning, Germany
Tel: 49-89-627-144 0 Fax: 49-89-627-144-44

Italy

Microchip Technology SRL
Centro Direzionale Colleoni
Palazzo Taurus 1 V. Le Colleoni 1
20041 Agrate Brianza
Milan, Italy
Tel: 39-039-65791-1 Fax: 39-039-6899883



United Kingdom

Microchip Ltd.
505 Eskdale Road
Winnersh Triangle
Wokingham
Berkshire, England RG41 5TU
Tel: 44 118 921 5869 Fax: 44-118 921-5820

12/05/02

Looking for pricing, stock, or lifecycle information?

Click below to explore more details on WIN SOURCE:

-  [View PIC16F628-04I/P on WIN SOURCE](#)
-  [Microchip Technology](#) Information

Optimize Your Supply Chain with WIN SOURCE Solutions

-  Global Sourcing Solution
-  Obsolete Management
-  Cost Control Management
-  Shortage Management
-  Alternative Solution
-  Excess Inventory Management