



PIC18F2458/2553/4458/4553

Data Sheet

28/40/44-Pin High-Performance,
Enhanced Flash, USB Microcontrollers
with 12-Bit A/D and nanoWatt Technology

Note the following details of the code protection feature on Microchip devices:

- Microchip products meet the specification contained in their particular Microchip Data Sheet.
- Microchip believes that its family of products is one of the most secure families of its kind on the market today, when used in the intended manner and under normal conditions.
- There are dishonest and possibly illegal methods used to breach the code protection feature. All of these methods, to our knowledge, require using the Microchip products in a manner outside the operating specifications contained in Microchip's Data Sheets. Most likely, the person doing so is engaged in theft of intellectual property.
- Microchip is willing to work with the customer who is concerned about the integrity of their code.
- Neither Microchip nor any other semiconductor manufacturer can guarantee the security of their code. Code protection does not mean that we are guaranteeing the product as "unbreakable."

Code protection is constantly evolving. We at Microchip are committed to continuously improving the code protection features of our products. Attempts to break Microchip's code protection feature may be a violation of the Digital Millennium Copyright Act. If such acts allow unauthorized access to your software or other copyrighted work, you may have a right to sue for relief under that Act.

Information contained in this publication regarding device applications and the like is provided only for your convenience and may be superseded by updates. It is your responsibility to ensure that your application meets with your specifications. MICROCHIP MAKES NO REPRESENTATIONS OR WARRANTIES OF ANY KIND WHETHER EXPRESS OR IMPLIED, WRITTEN OR ORAL, STATUTORY OR OTHERWISE, RELATED TO THE INFORMATION, INCLUDING BUT NOT LIMITED TO ITS CONDITION, QUALITY, PERFORMANCE, MERCHANTABILITY OR FITNESS FOR PURPOSE. Microchip disclaims all liability arising from this information and its use. Use of Microchip devices in life support and/or safety applications is entirely at the buyer's risk, and the buyer agrees to defend, indemnify and hold harmless Microchip from any and all damages, claims, suits, or expenses resulting from such use. No licenses are conveyed, implicitly or otherwise, under any Microchip intellectual property rights.

Trademarks

The Microchip name and logo, the Microchip logo, dsPIC, KEELOQ, KEELOQ logo, MPLAB, PIC, PICmicro, PICSTART, rPIC and UNI/O are registered trademarks of Microchip Technology Incorporated in the U.S.A. and other countries.

FilterLab, Hampshire, HI-TECH C, Linear Active Thermistor, MXDEV, MXLAB, SEEVAL and The Embedded Control Solutions Company are registered trademarks of Microchip Technology Incorporated in the U.S.A.

Analog-for-the-Digital Age, Application Maestro, CodeGuard, dsPICDEM, dsPICDEM.net, dsPICworks, dsSPEAK, ECAN, ECONOMONITOR, FanSense, HI-TIDE, In-Circuit Serial Programming, ICSP, Mindi, MiWi, MPASM, MPLAB Certified logo, MPLIB, MPLINK, mTouch, Octopus, Omniscient Code Generation, PICC, PICC-18, PICDEM, PICDEM.net, PICKit, PICTail, PIC³² logo, REAL ICE, rLAB, Select Mode, Total Endurance, TSHARC, UniWinDriver, WiperLock and ZENA are trademarks of Microchip Technology Incorporated in the U.S.A. and other countries.

SQTP is a service mark of Microchip Technology Incorporated in the U.S.A.

All other trademarks mentioned herein are property of their respective companies.

© 2009, Microchip Technology Incorporated, Printed in the U.S.A., All Rights Reserved.

 Printed on recycled paper.

QUALITY MANAGEMENT SYSTEM
CERTIFIED BY DNV
== ISO/TS 16949:2002 ==

Microchip received ISO/TS-16949:2002 certification for its worldwide headquarters, design and wafer fabrication facilities in Chandler and Tempe, Arizona; Gresham, Oregon and design centers in California and India. The Company's quality system processes and procedures are for its PIC[®] MCUs and dsPIC[®] DSCs, KEELOQ[®] code hopping devices, Serial EEPROMs, microperipherals, nonvolatile memory and analog products. In addition, Microchip's quality system for the design and manufacture of development systems is ISO 9001:2000 certified.



MICROCHIP

PIC18F2458/2553/4458/4553

28/40/44-Pin High-Performance, Enhanced Flash, USB Microcontrollers with 12-Bit A/D and nanoWatt Technology

Universal Serial Bus Features:

- USB V2.0 Compliant
- Low Speed (1.5 Mb/s) and Full Speed (12 Mb/s)
- Supports Control, Interrupt, Isochronous and Bulk Transfers
- Supports up to 32 Endpoints (16 bidirectional)
- 1-Kbyte Dual Access RAM for USB
- On-Chip USB Transceiver with On-Chip Voltage Regulator
- Interface for Off-Chip USB Transceiver
- Streaming Parallel Port (SPP) for USB Streaming Transfers (40/44-pin devices only)

Power-Managed Modes:

- Run: CPU On, Peripherals On
- Idle: CPU Off, Peripherals On
- Sleep: CPU Off, Peripherals Off
- Idle mode Currents Down to 5.8 μ A Typical
- Sleep mode Currents Down to 0.1 μ A Typical
- Timer1 Oscillator: 1.1 μ A Typical, 32 kHz, 2V
- Watchdog Timer: 2.1 μ A Typical
- Two-Speed Oscillator Start-up

Special Microcontroller Features:

- C Compiler Optimized Architecture with Optional Extended Instruction Set
- 100,000 Erase/Write Cycle Enhanced Flash Program Memory Typical
- 1,000,000 Erase/Write Cycle Data EEPROM Memory Typical
- Flash/Data EEPROM Retention: > 40 Years
- Self-Programmable under Software Control
- Priority Levels for Interrupts
- 8 x 8 Single-Cycle Hardware Multiplier
- Extended Watchdog Timer (WDT):
 - Programmable period from 41 ms to 131s
- Programmable Code Protection
- Single-Supply 5V In-Circuit Serial Programming™ (ICSP™) via Two Pins
- In-Circuit Debug (ICD) via Two Pins
- Optional Dedicated ICD/ICSP Port (44-pin TQFP package only)
- Wide Operating Voltage Range (2.0V to 5.5V)

Flexible Oscillator Structure:

- Four Crystal modes, Including High-Precision PLL for USB
- Two External Clock modes, up to 48 MHz
- Internal Oscillator Block:
 - 8 user-selectable frequencies, from 31 kHz to 8 MHz
 - User-tunable to compensate for frequency drift
- Secondary Oscillator using Timer1 @ 32 kHz
- Dual Oscillator Options allow Microcontroller and USB module to Run at Different Clock Speeds
- Fail-Safe Clock Monitor:
 - Allows for safe shutdown if any clock stops

Peripheral Highlights:

- High-Current Sink/Source: 25 mA/25 mA
- Three External Interrupts
- Four Timer modules (Timer0 to Timer3)
- Up to 2 Capture/Compare/PWM (CCP) modules:
 - Capture is 16-bit, max. resolution 5.2 ns ($T_{CY}/16$)
 - Compare is 16-bit, max. resolution 83.3 ns (T_{CY})
 - PWM output: PWM resolution is 1 to 10-bits
- Enhanced Capture/Compare/PWM (ECCP) module:
 - Multiple output modes
 - Selectable polarity
 - Programmable dead time
 - Auto-shutdown and auto-restart
- Enhanced USART module:
 - LIN bus support
- Master Synchronous Serial Port (MSSP) module supporting 3-wire SPI (all 4 modes) and I²C™ Master and Slave modes
- 12-Bit, up to 13-Channel Analog-to-Digital Converter module (A/D) with Programmable Acquisition Time
- Dual Analog Comparators with Input Multiplexing

Note: This document is supplemented by the "PIC18F2455/2550/4455/4550 Data Sheet" (DS39632). See **Section 1.0 "Device Overview"**.

Device	Program Memory		Data Memory		I/O	12-Bit A/D (ch)	CCP/ECCP (PWM)	SPP	MSSP		EUSART	Comp.	Timers 8/16-Bit
	Flash (bytes)	# Single-Word Instructions	SRAM (bytes)	EEPROM (bytes)					SPI	Master I ² C™			
PIC18F2458	24K	12288	2048	256	24	10	2/0	No	Y	Y	1	2	1/3
PIC18F2553	32K	16384			35	13	1/1	Yes					
PIC18F4458	24K	12288											
PIC18F4553	32K	16384											

PIC18F2458/2553/4458/4553

Pin Diagrams

28-Pin SPDIP, SOIC

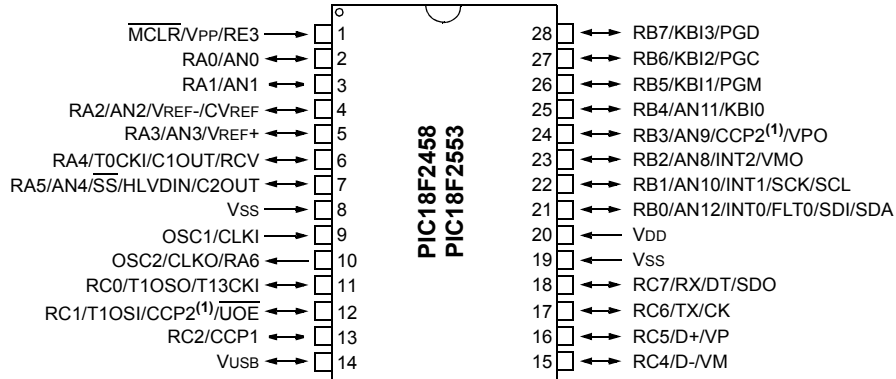

40-Pin PDIP

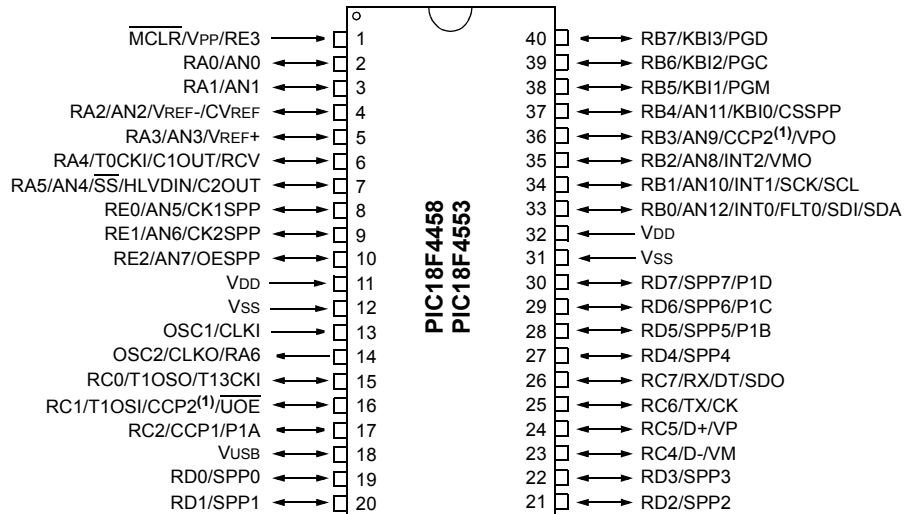

Note 1: RB3 is the alternate pin for CCP2 multiplexing.

PIC18F2458/2553/4458/4553

Pin Diagrams (Continued)

44-Pin TQFP

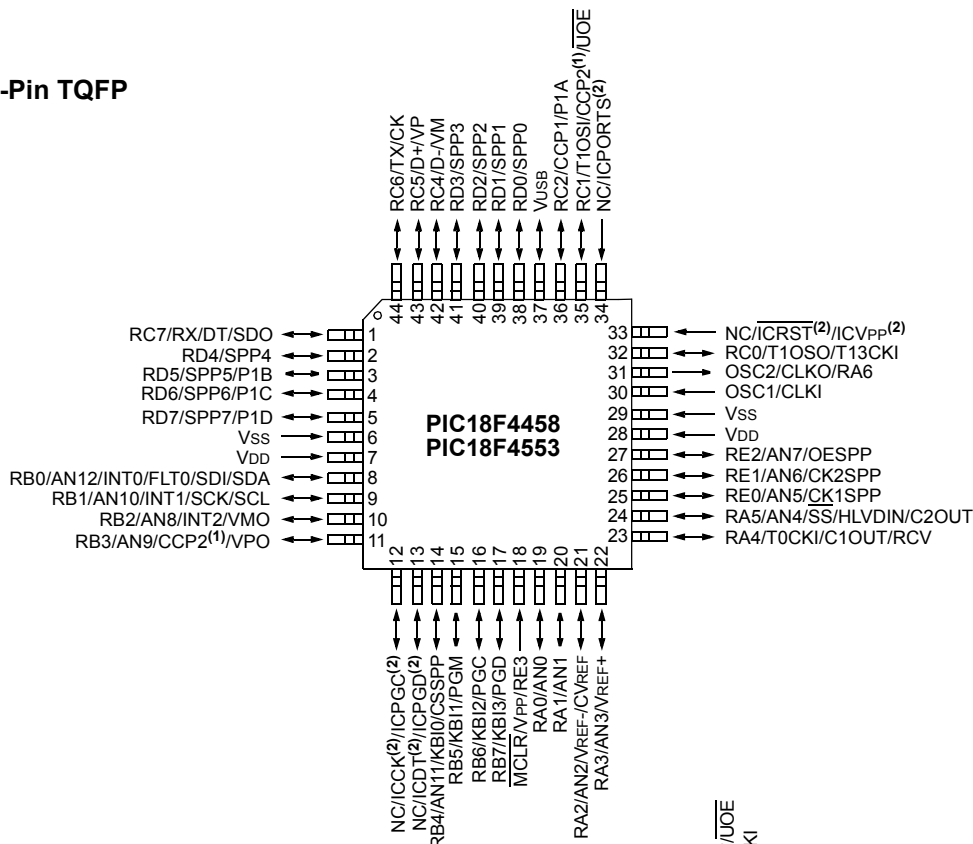

44-Pin QFN

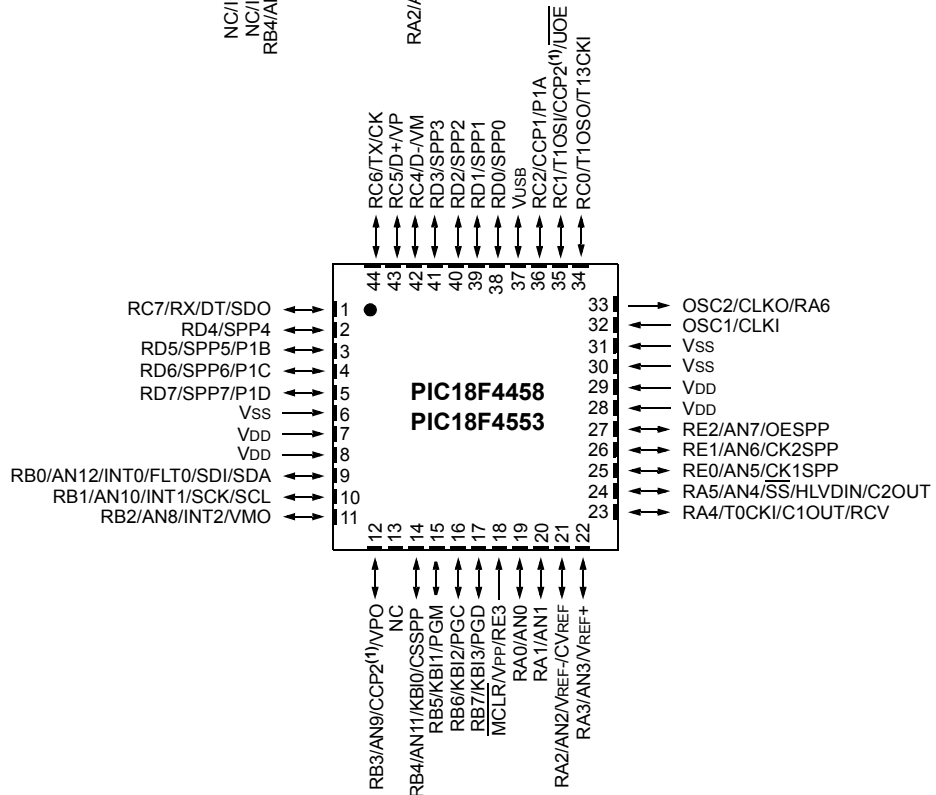

- Note** 1: RB3 is the alternate pin for CCP2 multiplexing.
 2: Special ICPORT features are available only in 44-pin TQFP packages. See Section 25.9 "Special ICPORT Features" in the "PIC18F2455/2550/4455/4550 Data Sheet".

PIC18F2458/2553/4458/4553

Table of Contents

1.0	Device Overview	7
2.0	12-Bit Analog-to-Digital Converter (A/D) Module	21
3.0	Special Features of the CPU	31
4.0	Electrical Characteristics	33
5.0	Packaging Information	37
	Appendix A: Revision History	39
	Appendix B: Device Differences	39
	Appendix C: Migration From Mid-Range to Enhanced Devices	40
	Appendix D: Migration From High-End to Enhanced Devices	40
	Index	41
	The Microchip Web Site	43
	Customer Change Notification Service	43
	Customer Support	43
	Reader Response	44
	Product Identification System	45

TO OUR VALUED CUSTOMERS

It is our intention to provide our valued customers with the best documentation possible to ensure successful use of your Microchip products. To this end, we will continue to improve our publications to better suit your needs. Our publications will be refined and enhanced as new volumes and updates are introduced.

If you have any questions or comments regarding this publication, please contact the Marketing Communications Department via E-mail at docerrors@microchip.com or fax the **Reader Response Form** in the back of this data sheet to (480) 792-4150. We welcome your feedback.

Most Current Data Sheet

To obtain the most up-to-date version of this data sheet, please register at our Worldwide Web site at:

<http://www.microchip.com>

You can determine the version of a data sheet by examining its literature number found on the bottom outside corner of any page. The last character of the literature number is the version number, (e.g., DS30000A is version A of document DS30000).

Errata

An errata sheet, describing minor operational differences from the data sheet and recommended workarounds, may exist for current devices. As device/documentation issues become known to us, we will publish an errata sheet. The errata will specify the revision of silicon and revision of document to which it applies.

To determine if an errata sheet exists for a particular device, please check with one of the following:

- Microchip's Worldwide Web site; <http://www.microchip.com>
- Your local Microchip sales office (see last page)

When contacting a sales office, please specify which device, revision of silicon and data sheet (include literature number) you are using.

Customer Notification System

Register on our web site at www.microchip.com to receive the most current information on all of our products.

PIC18F2458/2553/4458/4553

1.0 DEVICE OVERVIEW

This document contains device-specific information for the following devices:

- PIC18F2458
- PIC18F2553
- PIC18F4458
- PIC18F4553

Note: This data sheet documents only the devices' features and specifications that are in addition to the features and specifications of the PIC18F2455/2550/4455/4550 devices. For information on the features and specifications shared by the PIC18F2458/2553/4458/4553 and PIC18F2455/2550/4455/4550 devices, see the "PIC18F2455/2550/4455/4550 Data Sheet" (DS39632).

The PIC18F4553 family of devices offers the advantages of all PIC18 microcontrollers – namely, high computational performance at an economical price – with the addition of high-endurance, Enhanced Flash program memory. In addition to these features, the PIC18F4553 family introduces design enhancements that make these microcontrollers a logical choice for many high-performance, power sensitive applications.

1.1 Special Features

- **12-Bit A/D Converter:** The PIC18F4553 family implements a 12-bit A/D Converter. The A/D Converter incorporates programmable acquisition time. This allows for a channel to be selected and a conversion to be initiated, without waiting for a sampling period and thus, reducing code overhead.

1.2 Details on Individual Family Members

The PIC18F2458/2553/4458/4553 devices are available in 28-pin and 40/44-pin packages. Block diagrams for the two groups are shown in Figure 1-1 and Figure 1-2.

The devices are differentiated from each other in the following ways:

1. Flash program memory (24 Kbytes for PIC18FX458 devices, 32 Kbytes for PIC18FX553).
2. A/D channels (10 for 28-pin devices, 13 for 40-pin and 44-pin devices).
3. I/O ports (3 bidirectional ports and 1 input only port on 28-pin devices, 5 bidirectional ports on 40-pin and 44-pin devices).
4. CCP and Enhanced CCP implementation (28-pin devices have two standard CCP modules, 40-pin and 44-pin devices have one standard CCP module and one ECCP module).
5. Streaming Parallel Port (present only on 40/44-pin devices).

All other features for devices in this family are identical. These are summarized in Table 1-1.

The pinouts for all devices are listed in Table 1-2 and Table 1-3.

Members of the PIC18F4553 family are available as both standard and low-voltage devices. Standard devices with Enhanced Flash memory, designated with an "F" in the part number (such as PIC18F2458), accommodate an operating VDD range of 4.2V to 5.5V. Low-voltage parts, designated by "LF" (such as PIC18LF2458), function over an extended VDD range of 2.0V to 5.5V.

PIC18F2458/2553/4458/4553

TABLE 1-1: DEVICE FEATURES

Features	PIC18F2458	PIC18F2553	PIC18F4458	PIC18F4553
Operating Frequency	DC – 48 MHz	DC – 48 MHz	DC – 48 MHz	DC – 48 MHz
Program Memory (Bytes)	24576	32768	24576	32768
Program Memory (Instructions)	12288	16384	12288	16384
Data Memory (Bytes)	2048	2048	2048	2048
Data EEPROM Memory (Bytes)	256	256	256	256
Interrupt Sources	19	19	20	20
I/O Ports	Ports A, B, C, (E)	Ports A, B, C, (E)	Ports A, B, C, D, E	Ports A, B, C, D, E
Timers	4	4	4	4
Capture/Compare/PWM Modules	2	2	1	1
Enhanced Capture/Compare/PWM Modules	0	0	1	1
Serial Communications	MSSP, Enhanced USART	MSSP, Enhanced USART	MSSP, Enhanced USART	MSSP, Enhanced USART
Universal Serial Bus (USB) Module	1	1	1	1
Streaming Parallel Port (SPP)	No	No	Yes	Yes
12-Bit Analog-to-Digital Converter Module	10 Input Channels	10 Input Channels	13 Input Channels	13 Input Channels
Comparators	2	2	2	2
Resets (and Delays)	POR, BOR, WDT, RESET Instruction, Stack Full, Stack Underflow, MCLR (optional), (PWRT, OST)	POR, BOR, WDT, RESET Instruction, Stack Full, Stack Underflow, MCLR (optional), (PWRT, OST)	POR, BOR, WDT, RESET Instruction, Stack Full, Stack Underflow, MCLR (optional), (PWRT, OST)	POR, BOR, WDT, RESET Instruction, Stack Full, Stack Underflow, MCLR (optional), (PWRT, OST)
Programmable High/Low-Voltage Detect	Yes	Yes	Yes	Yes
Programmable Brown-out Reset	Yes	Yes	Yes	Yes
Instruction Set	75 Instructions; 83 with Extended Instruction Set Enabled	75 Instructions; 83 with Extended Instruction Set Enabled	75 Instructions; 83 with Extended Instruction Set Enabled	75 Instructions; 83 with Extended Instruction Set Enabled
Packages	28-Pin SPDIP 28-Pin SOIC	28-Pin SPDIP 28-Pin SOIC	40-Pin PDIP 44-Pin QFN 44-Pin TQFP	40-Pin PDIP 44-Pin QFN 44-Pin TQFP
Corresponding Devices with 10-Bit A/D	PIC18F2455	PIC18F2550	PIC18F4455	PIC18F4550

PIC18F2458/2553/4458/4553

FIGURE 1-1: PIC18F2458/2553 (28-PIN) BLOCK DIAGRAM

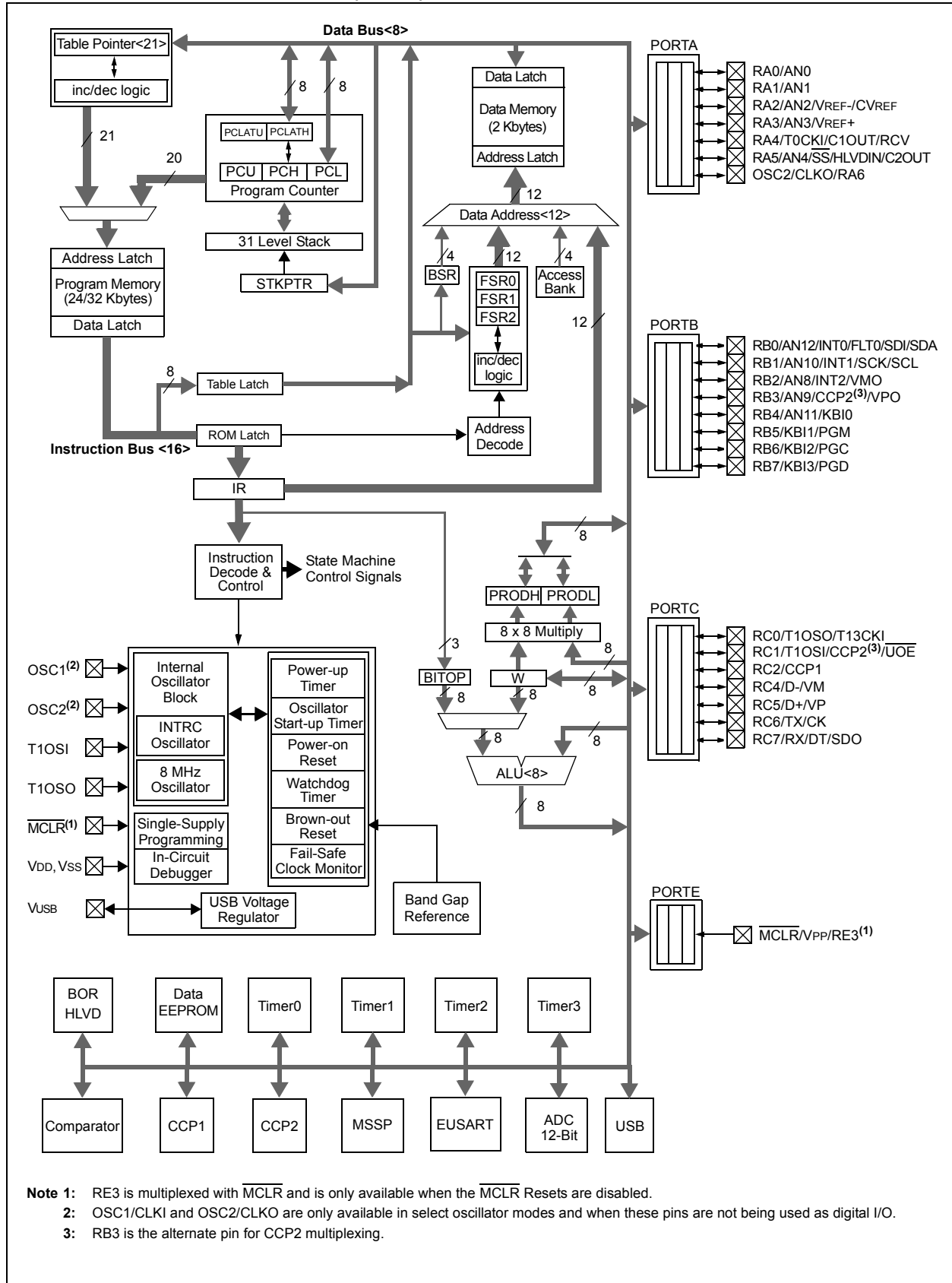

PIC18F2458/2553/4458/4553

FIGURE 1-2: PIC18F4458/4553(40/44-PIN) BLOCK DIAGRAM

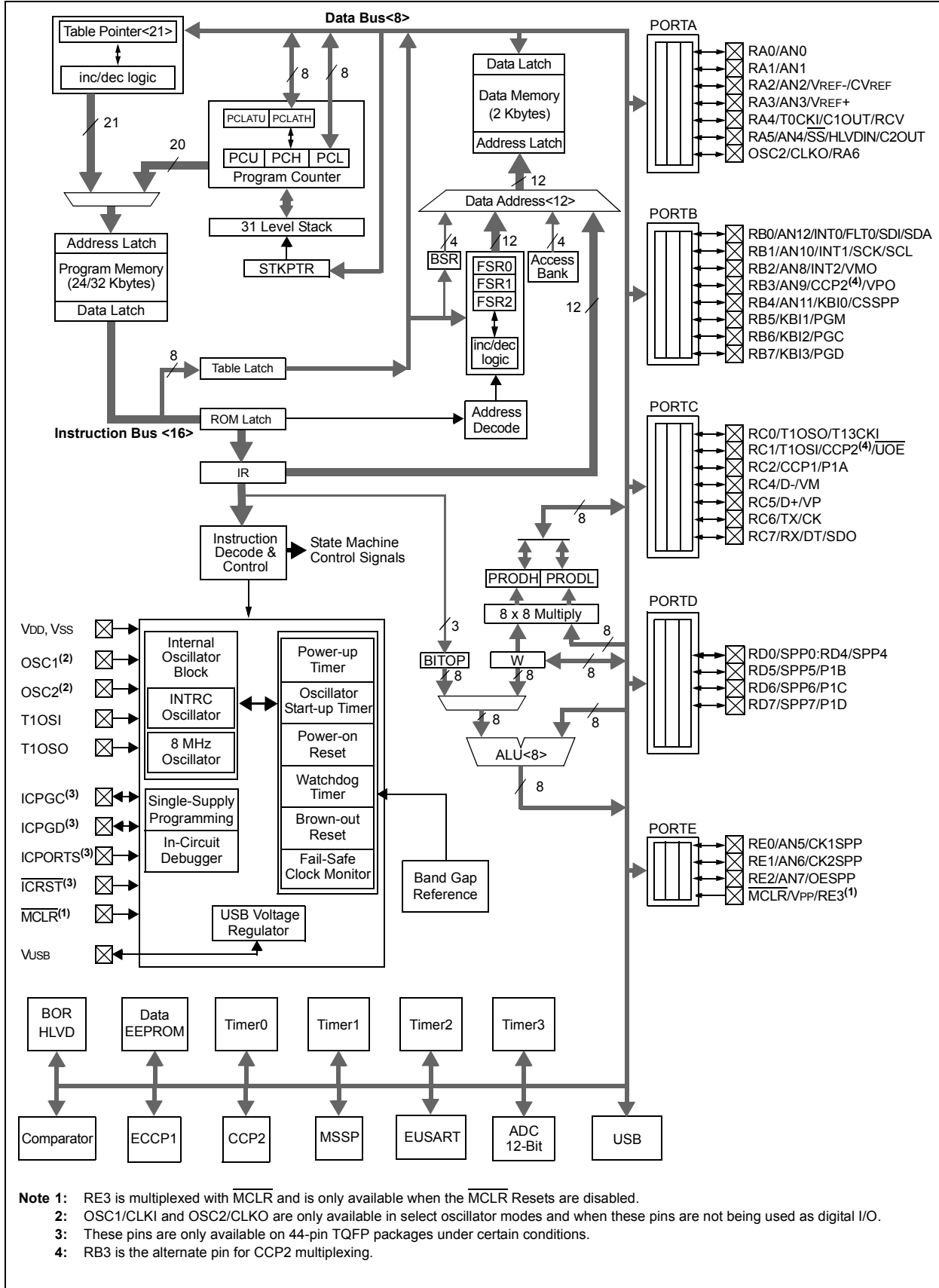

PIC18F2458/2553/4458/4553

TABLE 1-2: PIC18F2458/2553 PINOUT I/O DESCRIPTIONS (CONTINUED)

Pin Name	Pin Number	Pin Type	Buffer Type	Description	
	SPDIP, SOIC				
RA0/AN0	2	I/O	TTL	PORTA is a bidirectional I/O port. Digital I/O.	
RA0			Analog		Analog input 0.
AN0	3	I/O	TTL	Digital I/O.	
RA1/AN1			Analog		Analog input 1.
RA1			Analog		Analog input 1.
AN1	4	I/O	TTL	Digital I/O.	
RA2/AN2/VREF-/CVREF			Analog		Analog input 2.
RA2			Analog		A/D reference voltage (low) input.
AN2			Analog		Analog comparator reference output.
VREF-			Analog		Analog comparator reference output.
CVREF	5	I/O	TTL	Digital I/O.	
RA3/AN3/VREF+			Analog		Analog input 3.
RA3			Analog		A/D reference voltage (high) input.
AN3			Analog		A/D reference voltage (high) input.
VREF+	6	I/O	ST	Digital I/O.	
RA4/T0CKI/C1OUT/RCV			ST		Timer0 external clock input.
RA4			—		Comparator 1 output.
T0CKI			TTL		External USB transceiver RCV input.
C1OUT			—		External USB transceiver RCV input.
RCV	7	I/O	TTL	Digital I/O.	
RA5/AN4/ \overline{SS} /HLVDIN/C2OUT			Analog		Analog input 4.
RA5			TTL		SPI slave select input.
AN4			Analog		High/Low-Voltage Detect input.
\overline{SS}			—		Comparator 2 output.
HLVDIN			—		Comparator 2 output.
C2OUT	—	—	—	See the OSC2/CLKO/RA6 pin.	
RA6	—	—	—	See the OSC2/CLKO/RA6 pin.	

Legend: TTL = TTL compatible input CMOS = CMOS compatible input or output
 ST = Schmitt Trigger input with CMOS levels I = Input
 O = Output P = Power

Note 1: Alternate assignment for CCP2 when CCP2MX Configuration bit is cleared.
Note 2: Default assignment for CCP2 when CCP2MX Configuration bit is set.

PIC18F2458/2553/4458/4553

TABLE 1-3: PIC18F4458/4553 PINOUT I/O DESCRIPTIONS (CONTINUED)

Pin Name	Pin Number			Pin Type	Buffer Type	Description	
	PDIP	QFN	TQFP				
RA0/AN0	2	19	19	I/O	TTL	PORTA is a bidirectional I/O port. Digital I/O.	
RA0 AN0				I	Analog		Analog input 0.
RA1/AN1	3	20	20	I/O	TTL	Digital I/O.	
RA1 AN1				I	Analog		Analog input 1.
RA2/AN2/VREF-/ CVREF	4	21	21	I/O	TTL	Digital I/O.	
RA2				I	Analog		Analog input 2.
AN2				I	Analog		A/D reference voltage (low) input.
VREF- CVREF				O	Analog		Analog comparator reference output.
RA3/AN3/VREF+	5	22	22	I/O	TTL	Digital I/O.	
RA3				I	Analog		Analog input 3.
AN3 VREF+				I	Analog		A/D reference voltage (high) input.
RA4/T0CKI/C1OUT/ RCV	6	23	23	I/O	ST	Digital I/O.	
RA4				I	ST		Timer0 external clock input.
T0CKI				O	—		Comparator 1 output.
C1OUT RCV				I	TTL		External USB transceiver RCV input.
RA5/AN4/ \overline{SS} / HLVDIN/C2OUT	7	24	24	I/O	TTL	Digital I/O.	
RA5				I	Analog		Analog input 4.
AN4				I	TTL		SPI slave select input.
\overline{SS}				I	Analog		High/Low-Voltage Detect input.
HLVDIN C2OUT				O	—		Comparator 2 output.
RA6	—	—	—	—	—	See the OSC2/CLKO/RA6 pin.	

Legend: TTL = TTL compatible input CMOS = CMOS compatible input or output
 ST = Schmitt Trigger input with CMOS levels I = Input
 O = Output P = Power

- Note 1:** Alternate assignment for CCP2 when CCP2MX Configuration bit is cleared.
Note 2: Default assignment for CCP2 when CCP2MX Configuration bit is set.
Note 3: These pins are No Connect unless the ICPRT Configuration bit is set. For NC/ICPORTS, the pin is No Connect unless ICPRT is set and the DEBUG Configuration bit is cleared.

PIC18F2458/2553/4458/4553

2.0 12-BIT ANALOG-TO-DIGITAL CONVERTER (A/D) MODULE

The Analog-to-Digital (A/D) Converter module has 10 inputs for the 28-pin devices and 13 for the 40-pin and 44-pin devices. This module allows conversion of an analog input signal to a corresponding 12-bit digital number.

The module has five registers:

- A/D Result High Register (ADRESH)
- A/D Result Low Register (ADRESL)
- A/D Control Register 0 (ADCON0)
- A/D Control Register 1 (ADCON1)
- A/D Control Register 2 (ADCON2)

The ADCON0 register, shown in Register 2-1, controls the operation of the A/D module. The ADCON1 register, shown in Register 2-2, configures the functions of the port pins. The ADCON2 register, shown in Register 2-3, configures the A/D clock source, programmed acquisition time and justification.

REGISTER 2-1: ADCON0: A/D CONTROL REGISTER 0

U-0	U-0	R/W-0	R/W-0	R/W-0	R/W-0	R/W-0	R/W-0
—	—	CHS3	CHS2	CHS1	CHS0	GO/DONE	ADON
bit 7							bit 0

Legend:

R = Readable bit

W = Writable bit

U = Unimplemented bit, read as '0'

-n = Value at POR

'1' = Bit is set

'0' = Bit is cleared

x = Bit is unknown

bit 7-6 **Unimplemented:** Read as '0'

bit 5-2 **CHS3:CHS0:** Analog Channel Select bits

0000 = Channel 0 (AN0)

0001 = Channel 1 (AN1)

0010 = Channel 2 (AN2)

0011 = Channel 3 (AN3)

0100 = Channel 4 (AN4)

0101 = Channel 5 (AN5)^(1,2)

0110 = Channel 6 (AN6)^(1,2)

0111 = Channel 7 (AN7)^(1,2)

1000 = Channel 8 (AN8)

1001 = Channel 9 (AN9)

1010 = Channel 10 (AN10)

1011 = Channel 11 (AN11)

1100 = Channel 12 (AN12)

1101 = Unimplemented⁽²⁾

1110 = Unimplemented⁽²⁾

1111 = Unimplemented⁽²⁾

bit 1 **GO/DONE:** A/D Conversion Status bit

When ADON = 1:

1 = A/D conversion in progress

0 = A/D Idle

bit 0 **ADON:** A/D On bit

1 = A/D Converter module is enabled

0 = A/D Converter module is disabled

Note 1: These channels are not implemented on 28-pin devices.

2: Performing a conversion on unimplemented channels will return a floating input measurement.

PIC18F2458/2553/4458/4553

REGISTER 2-2: ADCON1: A/D CONTROL REGISTER 1

U-0	U-0	R/W-0	R/W-0	R/W-0	R/W ⁽¹⁾	R/W ⁽¹⁾	R/W ⁽¹⁾
—	—	VCFG1	VCFG0	PCFG3	PCFG2	PCFG1	PCFG0
bit 7							bit 0

Legend:

R = Readable bit W = Writable bit U = Unimplemented bit, read as '0'
 -n = Value at POR '1' = Bit is set '0' = Bit is cleared x = Bit is unknown

- bit 7-6 **Unimplemented:** Read as '0'
- bit 5 **VCFG1:** Voltage Reference Configuration bit (VREF- source)
 1 = VREF- (AN2)
 0 = VSS
- bit 4 **VCFG0:** Voltage Reference Configuration bit (VREF+ source)
 1 = VREF+ (AN3)
 0 = VDD
- bit 3-0 **PCFG3:PCFG0:** A/D Port Configuration Control bits:

PCFG3: PCFG0	AN12	AN11	AN10	AN9	AN8	AN7 ⁽²⁾	AN6 ⁽²⁾	AN5 ⁽²⁾	AN4	AN3	AN2	AN1	AN0
0000 ⁽¹⁾	A	A	A	A	A	A	A	A	A	A	A	A	A
0001	A	A	A	A	A	A	A	A	A	A	A	A	A
0010	A	A	A	A	A	A	A	A	A	A	A	A	A
0011	D	A	A	A	A	A	A	A	A	A	A	A	A
0100	D	D	A	A	A	A	A	A	A	A	A	A	A
0101	D	D	D	A	A	A	A	A	A	A	A	A	A
0110	D	D	D	D	A	A	A	A	A	A	A	A	A
0111 ⁽¹⁾	D	D	D	D	D	A	A	A	A	A	A	A	A
1000	D	D	D	D	D	D	A	A	A	A	A	A	A
1001	D	D	D	D	D	D	D	A	A	A	A	A	A
1010	D	D	D	D	D	D	D	D	A	A	A	A	A
1011	D	D	D	D	D	D	D	D	D	A	A	A	A
1100	D	D	D	D	D	D	D	D	D	D	A	A	A
1101	D	D	D	D	D	D	D	D	D	D	D	A	A
1110	D	D	D	D	D	D	D	D	D	D	D	D	A
1111	D	D	D	D	D	D	D	D	D	D	D	D	D

A = Analog input

D = Digital I/O

Note 1: The Reset value of the PCFG bits depends on the value of the PBDEN Configuration bit. When PBDEN = 1, PCFG<3:0> = 0000; when PBDEN = 0, PCFG<3:0> = 0111.

2: AN5 through AN7 are available only on 40-pin and 44-pin devices.

PIC18F2458/2553/4458/4553

REGISTER 2-3: ADCON2: A/D CONTROL REGISTER 2

R/W-0	U-0	R/W-0	R/W-0	R/W-0	R/W-0	R/W-0	R/W-0
ADFM	—	ACQT2	ACQT1	ACQT0	ADCS2	ADCS1	ADCS0
bit 7							bit 0

Legend:

R = Readable bit W = Writable bit U = Unimplemented bit, read as '0'
 -n = Value at POR '1' = Bit is set '0' = Bit is cleared x = Bit is unknown

- bit 7 **ADFM:** A/D Result Format Select bit
 1 = Right justified
 0 = Left justified
- bit 6 **Unimplemented:** Read as '0'
- bit 5-3 **ACQT2:ACQT0:** A/D Acquisition Time Select bits
 111 = 20 TAD
 110 = 16 TAD
 101 = 12 TAD
 100 = 8 TAD
 011 = 6 TAD
 010 = 4 TAD
 001 = 2 TAD
 000 = 0 TAD⁽¹⁾
- bit 2-0 **ADCS2:ADCS0:** A/D Conversion Clock Select bits
 111 = FRC (clock derived from A/D RC oscillator)⁽¹⁾
 110 = FOSC/64
 101 = FOSC/16
 100 = FOSC/4
 011 = FRC (clock derived from A/D RC oscillator)⁽¹⁾
 010 = FOSC/32
 001 = FOSC/8
 000 = FOSC/2

Note 1: If the A/D FRC clock source is selected, a delay of one T_{CY} (instruction cycle) is added before the A/D clock starts. This allows the *SLEEP* instruction to be executed before starting a conversion.

PIC18F2458/2553/4458/4553

The analog reference voltage is software selectable to either the device's positive and negative supply voltage (VDD and VSS), or the voltage level on the RA3/AN3/VREF+ and RA2/AN2/VREF-/CVREF pins.

The A/D Converter has a unique feature of being able to operate while the device is in Sleep mode. To operate in Sleep, the A/D conversion clock must be derived from the A/D's internal RC oscillator.

The output of the sample and hold is the input into the Converter, which generates the result via successive approximation.

A device Reset forces all registers to their Reset state. This forces the A/D module to be turned off and any conversion in progress is aborted.

Each port pin associated with the A/D Converter can be configured as an analog input or as a digital I/O. The ADRESH and ADRESL registers contain the result of the A/D conversion. When the A/D conversion is complete, the result is loaded into the ADRESH:ADRESL register pair, the GO/DONE bit (ADCON0 register) is cleared and the A/D Interrupt Flag bit, ADIF, is set. The block diagram of the A/D module is shown in Figure 2-1.

FIGURE 2-1: A/D BLOCK DIAGRAM

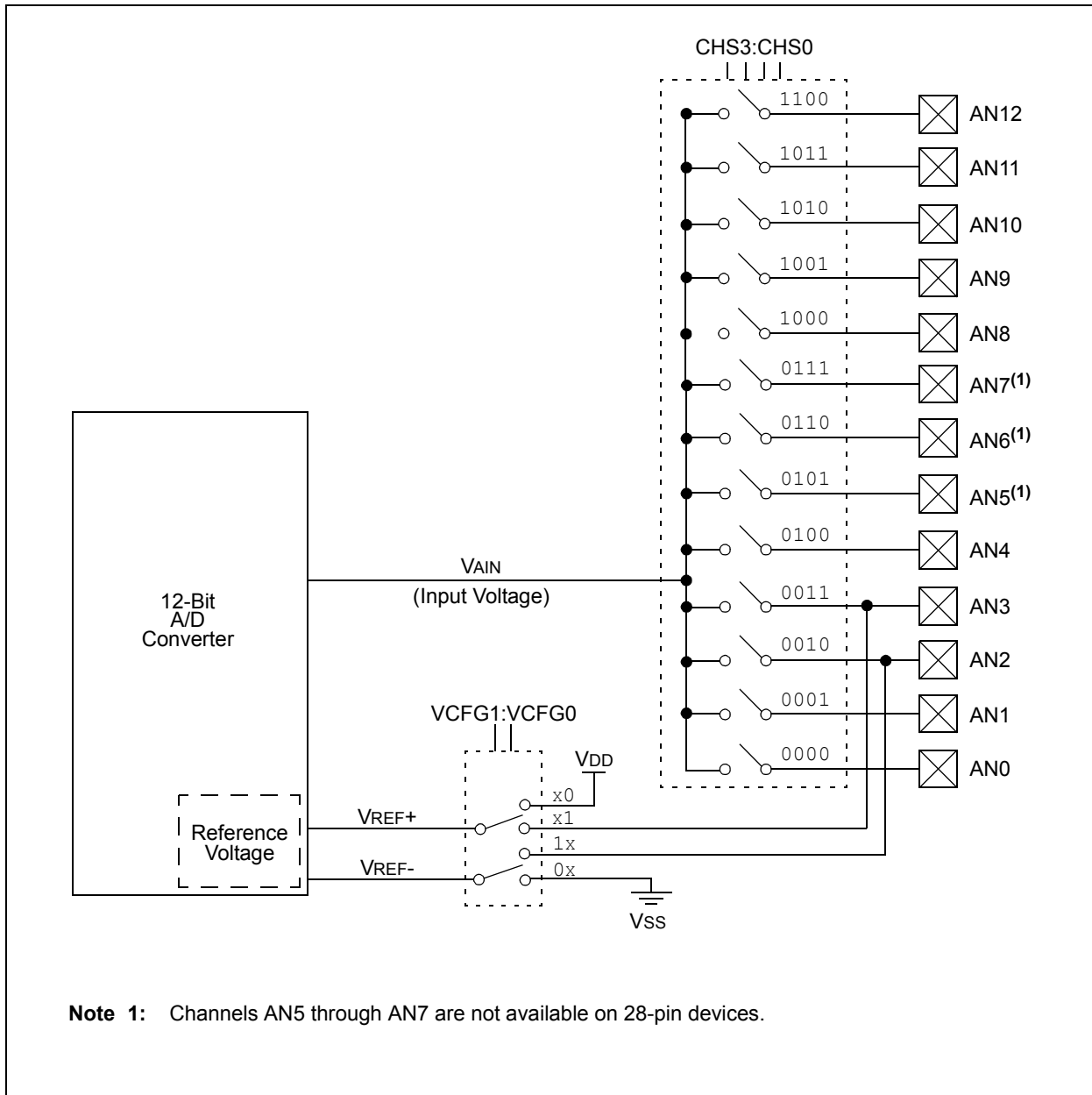

PIC18F2458/2553/4458/4553

The value in the ADRESH:ADRESL registers is unknown following Power-on and Brown-out Resets, and is not affected by any other Reset.

After the A/D module has been configured as desired, the selected channel must be acquired before the conversion is started. The analog input channels must have their corresponding TRIS bits selected as an input. To determine acquisition time, see **Section 2.1 “A/D Acquisition Requirements”**. After this acquisition time has elapsed, the A/D conversion can be started. An acquisition time can be programmed to occur between setting the GO/DONE bit and the actual start of the conversion.

The following steps should be followed to perform an A/D conversion:

1. Configure the A/D module:
 - Configure analog pins, voltage reference and digital I/O (ADCON1)
 - Select A/D input channel (ADCON0)
 - Select A/D acquisition time (ADCON2)
 - Select A/D conversion clock (ADCON2)
 - Turn on A/D module (ADCON0)
2. Configure A/D interrupt (if desired):
 - Clear ADIF bit
 - Set ADIE bit
 - Set GIE bit
3. Wait the required acquisition time (if required).
4. Start conversion:
 - Set GO/DONE bit (ADCON0 register)

5. Wait for A/D conversion to complete, by either:
 - Polling for the GO/DONE bit to be cleared
 OR
 - Waiting for the A/D interrupt
6. Read A/D Result registers (ADRESH:ADRESL); clear bit ADIF, if required.
7. For next conversion, go to step 1 or step 2, as required. The A/D conversion time per bit is defined as T_{AD}. A minimum wait of 2 T_{AD} is required before the next acquisition starts.

FIGURE 2-2: A/D TRANSFER FUNCTION

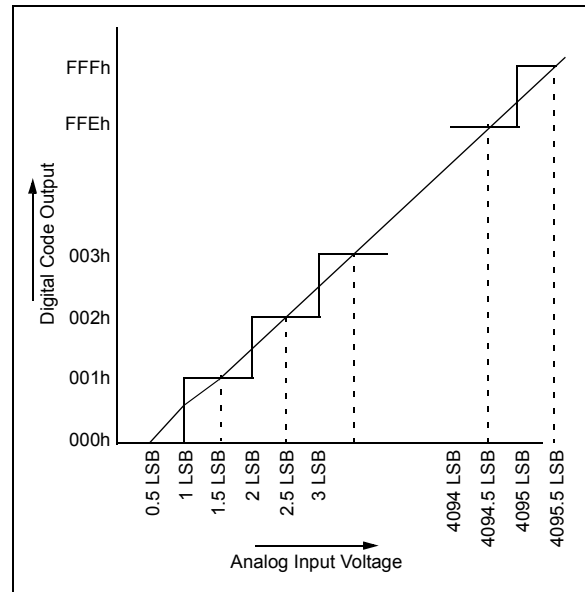
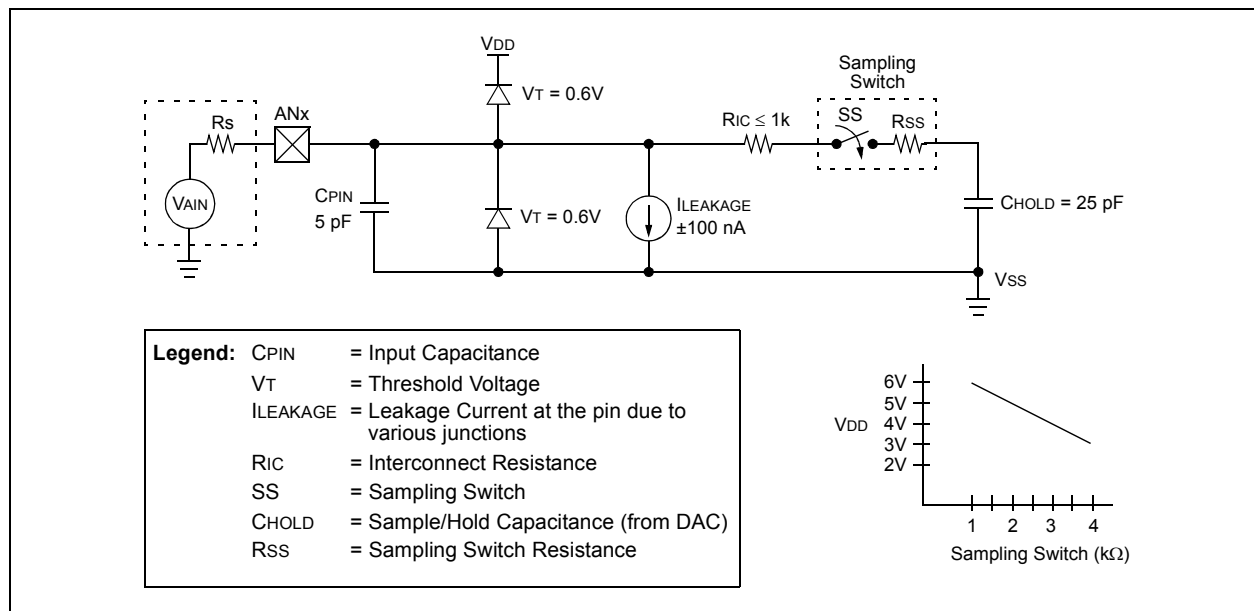

FIGURE 2-3: ANALOG INPUT MODEL



PIC18F2458/2553/4458/4553

2.1 A/D Acquisition Requirements

For the A/D Converter to meet its specified accuracy, the charge holding capacitor (CHOLD) must be allowed to fully charge to the input channel voltage level. The analog input model is shown in Figure 2-3. The source impedance (Rs) and the internal sampling switch (Rss) impedance directly affect the time required to charge the capacitor CHOLD. The sampling switch (Rss) impedance varies over the device voltage (VDD). The source impedance affects the offset voltage at the analog input (due to pin leakage current). **The maximum recommended impedance for analog sources is 2.5 kΩ.** After the analog input channel is selected (changed), the channel must be sampled for at least the minimum acquisition time before starting a conversion.

Note: When the conversion is started, the holding capacitor is disconnected from the input pin.

To calculate the minimum acquisition time, Equation 2-1 may be used. This equation assumes that 1/2 LSB error is used (4096 steps for the 12-bit A/D). The 1/2 LSB error is the maximum error allowed for the A/D to meet its specified resolution.

Example 2-3 shows the calculation of the minimum required acquisition time, TACQ. This calculation is based on the following application system assumptions:

CHOLD	=	25 pF
Rs	=	2.5 kΩ
Conversion Error	≤	1/2 LSB
VDD	=	3V → Rss = 4 kΩ
Temperature	=	85°C (system max.)

EQUATION 2-1: ACQUISITION TIME

$$\begin{aligned} \text{TACQ} &= \text{Amplifier Settling Time} + \text{Holding Capacitor Charging Time} + \text{Temperature Coefficient} \\ &= \text{TAMP} + \text{TC} + \text{TCOFF} \end{aligned}$$

EQUATION 2-2: A/D MINIMUM CHARGING TIME

$$\begin{aligned} \text{V}_{\text{HOLD}} &= (\text{V}_{\text{REF}} - (\text{V}_{\text{REF}}/4096)) \cdot (1 - e^{-(\text{TC}/\text{CHOLD})(\text{RIC} + \text{R}_{\text{SS}} + \text{R}_{\text{S}})}) \\ \text{or} \\ \text{TC} &= -(\text{CHOLD})(\text{RIC} + \text{R}_{\text{SS}} + \text{R}_{\text{S}}) \ln(1/4096) \end{aligned}$$

EQUATION 2-3: CALCULATING THE MINIMUM REQUIRED ACQUISITION TIME

$$\text{TACQ} = \text{TAMP} + \text{TC} + \text{TCOFF}$$

$$\text{TAMP} = 0.2 \mu\text{s}$$

$$\begin{aligned} \text{TCOFF} &= (\text{Temp} - 25^\circ\text{C})(0.02 \mu\text{s}/^\circ\text{C}) \\ &= (85^\circ\text{C} - 25^\circ\text{C})(0.02 \mu\text{s}/^\circ\text{C}) \\ &= 1.2 \mu\text{s} \end{aligned}$$

Temperature coefficient is only required for temperatures > 25°C. Below 25°C, TCOFF = 0 μs.

$$\begin{aligned} \text{TC} &= -(\text{CHOLD})(\text{RIC} + \text{R}_{\text{SS}} + \text{R}_{\text{S}}) \ln(1/4096) \mu\text{s} \\ &= (25 \text{ pF})(1 \text{ k}\Omega + 4 \text{ k}\Omega + 2.5 \text{ k}\Omega) \ln(0.0002441) \mu\text{s} \\ &= 1.56 \mu\text{s} \end{aligned}$$

$$\begin{aligned} \text{TACQ} &= 0.2 \mu\text{s} + 1.56 \mu\text{s} + 1.2 \mu\text{s} \\ &= 2.96 \mu\text{s} \end{aligned}$$

2.2 Selecting and Configuring Acquisition Time

The ADCON2 register allows the user to select an acquisition time that occurs each time the GO/DONE bit is set. It also gives users the option to use an automatically determined acquisition time.

Acquisition time may be set with the ACQT2:ACQT0 bits (ADCON2<5:3>), which provides a range of 2 to 20 TAD. When the GO/DONE bit is set, the A/D module continues to sample the input for the selected acquisition time, then automatically begins a conversion. Since the acquisition time is programmed, there may be no need to wait for an acquisition time between selecting a channel and setting the GO/DONE bit.

Manual acquisition is selected when ACQT2:ACQT0 = 000. When the GO/DONE bit is set, sampling is stopped and a conversion begins. The user is responsible for ensuring the required acquisition time has passed between selecting the desired input channel and setting the GO/DONE bit. This option is also the default Reset state of the ACQT2:ACQT0 bits and is compatible with devices that do not offer programmable acquisition times.

In either case, when the conversion is completed, the GO/DONE bit is cleared, the ADIF flag is set and the A/D begins sampling the currently selected channel again. If an acquisition time is programmed, there is nothing to indicate if the acquisition time has ended or if the conversion has begun.

2.3 Selecting the A/D Conversion Clock

The A/D conversion time per bit is defined as TAD. The A/D conversion requires 13 TAD per 12-bit conversion. The source of the A/D conversion clock is software selectable. There are seven possible options for TAD:

- 2 TOSC
- 4 TOSC
- 8 TOSC
- 16 TOSC
- 32 TOSC
- 64 TOSC
- Internal RC Oscillator

For correct A/D conversions, the A/D conversion clock (TAD) must be as short as possible, but greater than the minimum TAD (see parameter 130 for more information).

Table 2-1 shows the resultant TAD times derived from the device operating frequencies and the A/D clock source selected.

TABLE 2-1: TAD vs. DEVICE OPERATING FREQUENCIES

A/D Clock Source (TAD)		Assumes TAD Min. = 0.8 μ s
Operation	ADCS2:ADCS0	Maximum FOSC
2 TOSC	000	2.50 MHz
4 TOSC	100	5.00 MHz
8 TOSC	001	10.00 MHz
16 TOSC	101	20.00 MHz
32 TOSC	010	40.00 MHz
64 TOSC	110	48.00 MHz
RC ⁽¹⁾	x11	1.00 MHz ⁽²⁾

Note 1: The RC source has a typical TAD time of 2.5 μ s.

- 2:** For device frequencies above 1 MHz, the device must be in Sleep for the entire conversion or a FOSC divider should be used instead; otherwise, the A/D accuracy specification may not be met.

PIC18F2458/2553/4458/4553

2.4 Operation in Power-Managed Modes

The selection of the automatic acquisition time and A/D conversion clock is determined in part by the clock source and frequency while in a power-managed mode.

If the A/D is expected to operate while the device is in a power-managed mode, the AD_{CS}2:AD_{CS}0 bits in AD_{CON}2 should be updated in accordance with the clock source to be used. The AC_{QT}2:AC_{QT}0 bits do not need to be adjusted as the AD_{CS}2:AD_{CS}0 bits adjust the T_{AD} time for the new clock speed. After entering the mode, an A/D acquisition or conversion may be started. Once started, the device should continue to be clocked by the same clock source until the conversion has been completed.

If desired, the device may be placed into the corresponding Idle mode during the conversion. If the device clock frequency is less than 1 MHz, the A/D RC clock source should be selected.

Operation in Sleep mode requires the A/D F_{RC} clock to be selected. If bits AC_{QT}2:AC_{QT}0 are set to '000' and a conversion is started, the conversion will be delayed one instruction cycle to allow execution of the `SLEEP` instruction and entry to Sleep mode. The ID_{LEN} bit (OS_{CCON}<7>) must have already been cleared prior to starting the conversion.

2.5 Configuring Analog Port Pins

The AD_{CON}1, TRISA, TRISB and TRISE registers all configure the A/D port pins. The port pins needed as analog inputs must have their corresponding TRIS bits set (input). If the TRIS bit is cleared (output), the digital output level (V_{OH} or V_{OL}) will be converted.

The A/D operation is independent of the state of the CH_S3:CH_S0 bits and the TRIS bits.

- | |
|--|
| <p>Note 1: When reading the PORT register, all pins configured as analog input channels will read as cleared (a low level). Analog conversion on pins configured as digital pins can be performed. The voltage on the pin will be accurately converted.</p> <p>2: Analog levels on any pin defined as a digital input may cause the digital input buffer to consume current out of the device's specification limits.</p> <p>3: The P_{BADEN} bit in Configuration Register 3H configures PORTB pins to reset as analog or digital pins by controlling how the PC_{FG}3:PC_{FG}0 bits in AD_{CON}1 are reset.</p> |
|--|

2.6 A/D Conversions

Figure 2-4 shows the operation of the A/D Converter after the $\overline{\text{GO/DONE}}$ bit has been set and the ACQT2:ACQT0 bits are cleared. A conversion is started after the following instruction to allow entry into Sleep mode before the conversion begins.

Figure 2-5 shows the operation of the A/D Converter after the $\overline{\text{GO/DONE}}$ bit has been set and the ACQT2:ACQT0 bits are set to '010', and selecting a 4 TAD acquisition time before the conversion starts.

Clearing the $\overline{\text{GO/DONE}}$ bit during a conversion will abort the current conversion. The A/D Result register pair will NOT be updated with the partially completed A/D conversion sample. This means the ADRESH:ADRESL registers will continue to contain the value of the last completed conversion (or the last value written to the ADRESH:ADRESL registers).

After the A/D conversion is completed or aborted, a $2 T_{CY}$ wait is required before the next acquisition can be started. After this wait, acquisition on the selected channel is automatically started.

Note: The $\overline{\text{GO/DONE}}$ bit should **NOT** be set in the same instruction that turns on the A/D. Code should wait at least $2 \mu\text{s}$ after enabling the A/D before beginning an acquisition and conversion cycle.

2.7 Discharge

The discharge phase is used to initialize the value of the holding capacitor. The array is discharged before every sample. This feature helps to optimize the unity gain amplifier, as the circuit always needs to charge the capacitor array, rather than charge/discharge based on previous measure values.

FIGURE 2-4: A/D CONVERSION TAD CYCLES (ACQT<2:0> = 000, TACQ = 0)

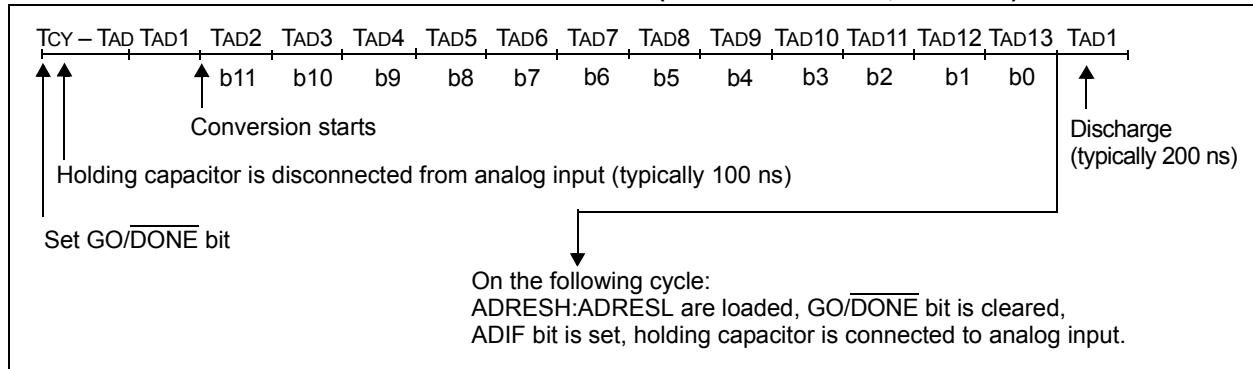
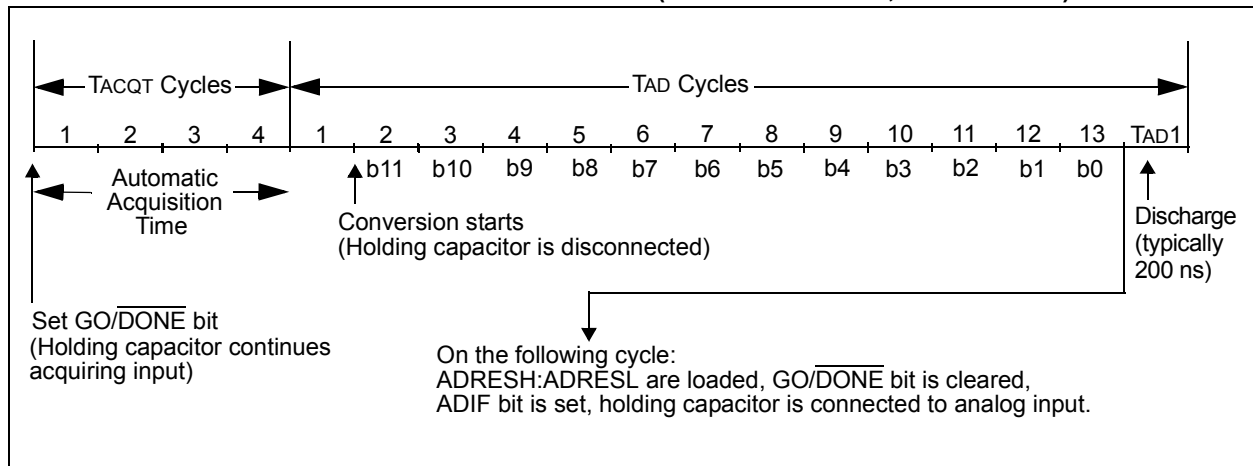

FIGURE 2-5: A/D CONVERSION TAD CYCLES (ACQT<2:0> = 010, TACQ = 4 TAD)



PIC18F2458/2553/4458/4553

2.8 Use of the CCP2 Trigger

An A/D conversion can be started by the Special Event Trigger of the CCP2 module. This requires that the CCP2M3:CCP2M0 bits (CCP2CON<3:0>) be programmed as '1011' and that the A/D module is enabled (ADON bit is set). When the trigger occurs, the GO/DONE bit will be set, starting the A/D acquisition and conversion, and the Timer1 (or Timer3) counter will be reset to zero. Timer1 (or Timer3) is reset to automatically repeat the A/D acquisition period with minimal software overhead (firmware must move ADRESH:ADRESL to

the desired location). The appropriate analog input channel must be selected and the minimum acquisition period is either timed by the user, or an appropriate TACQ time selected before the Special Event Trigger sets the GO/DONE bit (starts a conversion).

If the A/D module is not enabled (ADON is cleared), the Special Event Trigger will be ignored by the A/D module, but will still reset the Timer1 (or Timer3) counter.

TABLE 2-2: REGISTERS ASSOCIATED WITH A/D OPERATION

Name	Bit 7	Bit 6	Bit 5	Bit 4	Bit 3	Bit 2	Bit 1	Bit 0	Reset Values on Page:
INTCON	GIE/GIEH	PEIE/GIEL	TMR0IE	INT0IE	RBIE	TMR0IF	INT0IF	RBIF	(4)
PIR1	SPPIF ⁽¹⁾	ADIF	RCIF	TXIF	SSPIF	CCP1IF	TMR2IF	TMR1IF	(4)
PIE1	SPPIE ⁽¹⁾	ADIE	RCIE	TXIE	SSPIE	CCP1IE	TMR2IE	TMR1IE	(4)
IPR1	SPPIP ⁽¹⁾	ADIP	RCIP	TXIP	SSPIP	CCP1IP	TMR2IP	TMR1IP	(4)
PIR2	OSCFIF	CMIF	USBIF	EEIF	BCLIF	HLVDIF	TMR3IF	CCP2IF	(4)
PIE2	OSCFIE	CMIE	USBIE	EEIE	BCLIE	HLVDIE	TMR3IE	CCP2IE	(4)
IPR2	OSCFIP	CMIP	USBIP	EEIP	BCLIP	HLVDIP	TMR3IP	CCP2IP	(4)
ADRESH	A/D Result Register High Byte								(4)
ADRESL	A/D Result Register Low Byte								(4)
ADCON0	—	—	CHS3	CHS2	CHS1	CHS0	GO/DONE	ADON	21
ADCON1	—	—	VCFG1	VCFG0	PCFG3	PCFG2	PCFG1	PCFG0	22
ADCON2	ADFM	—	ACQT2	ACQT1	ACQT0	ADCS2	ADCS1	ADCS0	23
PORTA	—	RA6 ⁽²⁾	RA5	RA4	RA3	RA2	RA1	RA0	(4)
TRISA	—	TRISA6 ⁽²⁾	PORTA Data Direction Control Register						(4)
PORTB	RB7	RB6	RB5	RB4	RB3	RB2	RB1	RB0	(4)
TRISB	PORTB Data Direction Control Register								(4)
LATB	PORTB Data Latch Register (Read and Write to Data Latch)								(4)
PORTE ⁽¹⁾	RDPU	—	—	—	RE3 ⁽³⁾	RE2 ⁽¹⁾	RE1 ⁽¹⁾	RE0 ⁽¹⁾	(4)
TRISE ⁽¹⁾	—	—	—	—	—	TRISE2	TRISE1	TRISE0	(4)
LATE ⁽¹⁾	—	—	—	—	—	PORTE Data Latch Register			(4)

Legend: — = unimplemented, read as '0'. Shaded cells are not used for A/D conversion.

Note 1: These registers and/or bits are not implemented on 28-pin devices and are read as '0'.

2: RA6 and its associated latch and data direction bits are enabled as I/O pins based on oscillator configuration; otherwise, they are read as '0'.

3: RE3 port bit is available only as an input pin when the MCLRE Configuration bit is '0'.

4: For these Reset values, see the "PIC18F2455/2550/4455/4550 Data Sheet".

PIC18F2458/2553/4458/4553

3.0 SPECIAL FEATURES OF THE CPU

Note: For additional details on the Configuration bits, refer to the “PIC18F2455/2550/4455/4550 Data Sheet”, Section 25.1 “Configuration Bits”. Device ID information presented in this section is for PIC18F2458/2553/4458/4553 only.

PIC18F2458/2553/4458/4553 devices include several features intended to maximize reliability and minimize cost through elimination of external components. These include:

- Device ID Registers

3.1 Device ID Registers

The Device ID registers are “read-only” registers. They identify the device type and revision to device programmers, and can be read by firmware using table reads.

TABLE 3-1: DEVICE IDs

File Name	Bit 7	Bit 6	Bit 5	Bit 4	Bit 3	Bit 2	Bit 1	Bit 0	Default/ Unprogrammed Value	
3FFFFEh	DEVID1	DEV2	DEV1	DEV0	REV4	REV3	REV2	REV1	REV0	xxxx xxxx ⁽¹⁾
3FFFFFh	DEVID2	DEV10	DEV9	DEV8	DEV7	DEV6	DEV5	DEV4	DEV3	xxxx xxxx ⁽¹⁾

Legend: x = unknown, u = unchanged

Note 1: See Register 3-1 and Register 3-2 for DEVID values. DEVID registers are read-only and cannot be programmed by the user.

PIC18F2458/2553/4458/4553

REGISTER 3-1: DEVID1: DEVICE ID REGISTER 1 FOR PIC18F2458/2553/4458/4553 DEVICES

R	R	R	R	R	R	R	R
DEV2	DEV1	DEV0	REV4	REV3	REV2	REV1	REV0
bit 7							bit 0

Legend:

R = Read-only bit P = Programmable bit U = Unimplemented bit, read as '0'
 -n = Value when device is unprogrammed u = Unchanged from programmed state

bit 7-5 **DEV2:DEV0:** Device ID bits
 See Register 3-2 for a complete listing.

bit 4-0 **REV3:REV0:** Revision ID bits
 These bits are used to indicate the device revision.

REGISTER 3-2: DEVID2: DEVICE ID REGISTER 2 FOR PIC18F2458/2553/4458/4553 DEVICES

R	R	R	R	R	R	R	R
DEV10	DEV9	DEV8	DEV7	DEV6	DEV5	DEV4	DEV3
bit 7							bit 0

Legend:

R = Read-only bit P = Programmable bit U = Unimplemented bit, read as '0'
 -n = Value when device is unprogrammed u = Unchanged from programmed state

bit 7-0 **DEV10:DEV3:** Device ID bits

DEV10:DEV3 (DEVID2<7:0>)	DEV2:DEV0 (DEVID1<7:5>)	Device
0010 1010	011	PIC18F2458
0010 1010	010	PIC18F2553
0010 1010	001	PIC18F4458
0010 1010	000	PIC18F4553

4.0 ELECTRICAL CHARACTERISTICS

Absolute Maximum Ratings †)

Ambient temperature under bias	-40°C to +125°C
Storage temperature	-65°C to +150°C
Voltage on any pin with respect to VSS (except VDD and $\overline{\text{MCLR}}$)	-0.3V to (VDD + 0.3V)
Voltage on VDD with respect to VSS	-0.3V to +7.5V
Voltage on $\overline{\text{MCLR}}$ with respect to VSS (Note 2)	0V to +13.25V
Total power dissipation (Note 1)	1.0W
Maximum current out of VSS pin	300 mA
Maximum current into VDD pin	250 mA
Input clamp current, I _{IK} (V _I < 0 or V _I > VDD)	±20 mA
Output clamp current, I _{OK} (V _O < 0 or V _O > VDD)	±20 mA
Maximum output current sunk by any I/O pin	25 mA
Maximum output current sourced by any I/O pin	25 mA
Maximum current sunk by all ports	200 mA
Maximum current sourced by all ports	200 mA

Note 1: Power dissipation is calculated as follows:

$$P_{dis} = V_{DD} \times \{I_{DD} - \sum I_{OH}\} + \sum \{(V_{DD} - V_{OH}) \times I_{OH}\} + \sum (V_{OL} \times I_{OL})$$

- 2:** Voltage spikes below VSS at the $\overline{\text{MCLR}}/\text{VPP}/\text{RE3}$ pin, inducing currents greater than 80 mA, may cause latch-up. Thus, a series resistor of 50-100Ω should be used when applying a “low” level to the $\overline{\text{MCLR}}/\text{VPP}/\text{RE3}$ pin, rather than pulling this pin directly to VSS.

† **NOTICE:** Stresses above those listed under “Absolute Maximum Ratings” may cause permanent damage to the device. This is a stress rating only and functional operation of the device at those or any other conditions above those indicated in the operation listings of this specification is not implied. Exposure to maximum rating conditions for extended periods may affect device reliability.

PIC18F2458/2553/4458/4553

FIGURE 4-1: PIC18F2458/2553/4458/4553 VOLTAGE-FREQUENCY GRAPH (INDUSTRIAL)

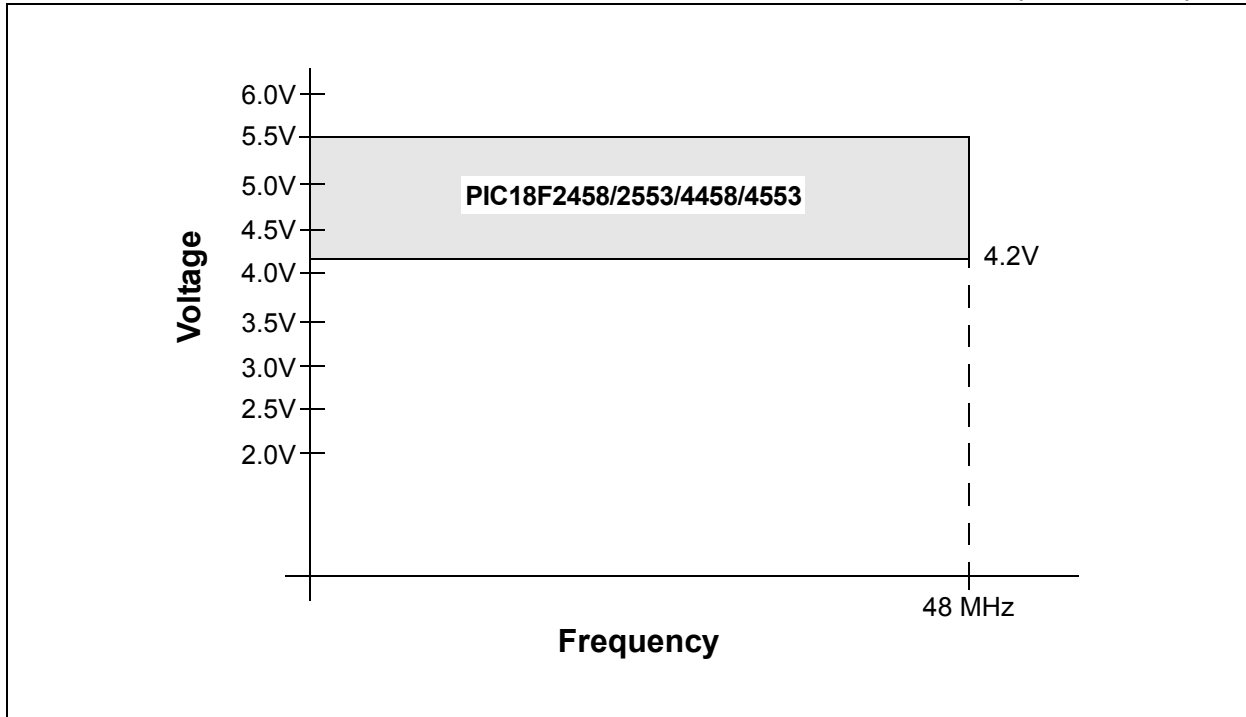
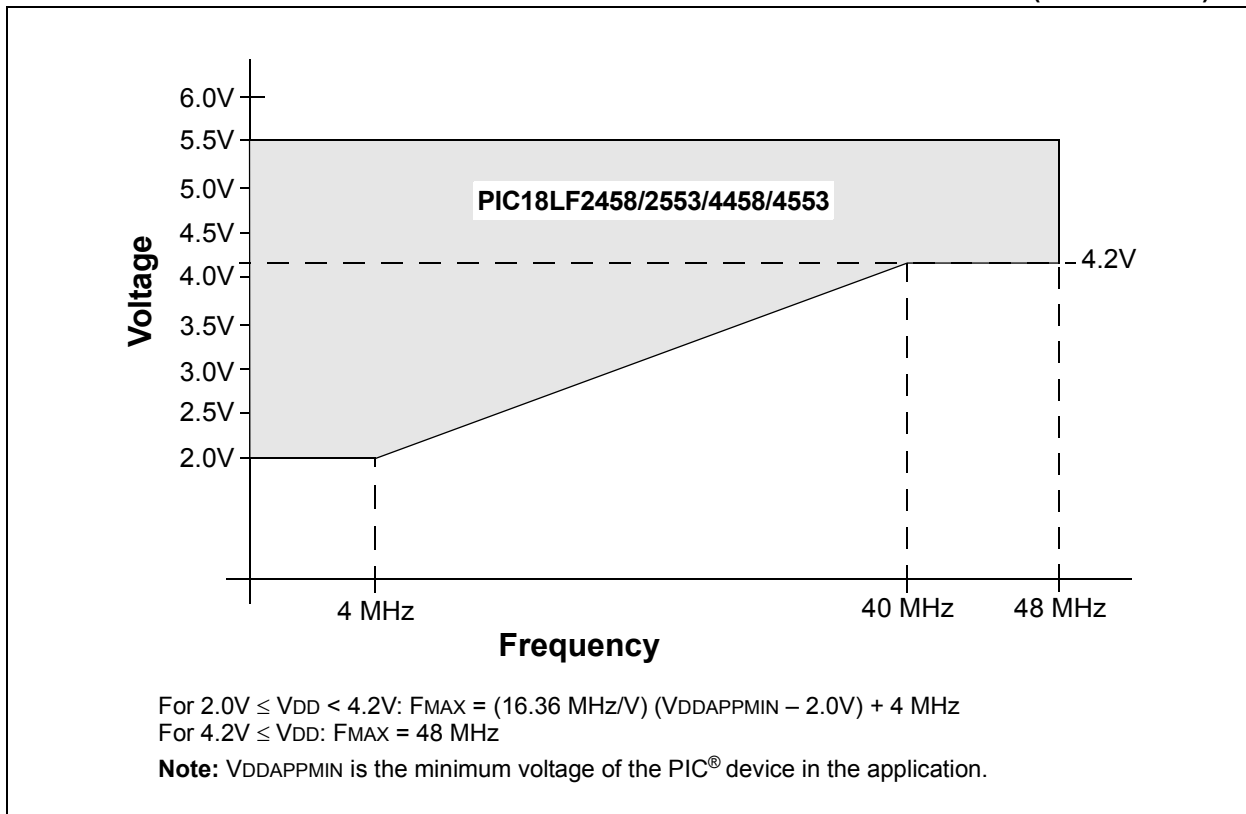

FIGURE 4-2: PIC18LF2458/2553/4458/4553 VOLTAGE-FREQUENCY GRAPH (INDUSTRIAL)



PIC18F2458/2553/4458/4553

**TABLE 4-1: A/D CONVERTER CHARACTERISTICS: PIC18F2458/2553/4458/4553 (INDUSTRIAL)
PIC18LF2458/2553/4458/4553 (INDUSTRIAL)**

Param No.	Sym	Characteristic	Min	Typ	Max	Units	Conditions	
A01	NR	Resolution	—	—	12	bit		$\Delta V_{REF} \geq 3.0V$
A03	EIL	Integral Linearity Error	—	± 1	± 2.0	LSB	$V_{DD} = 3.0V$	$\Delta V_{REF} \geq 3.0V$
			—	—	± 2.0	LSB	$V_{DD} = 5.0V$	
A04	EDL	Differential Linearity Error	—	± 1	+1.5/-1.0	LSB	$V_{DD} = 3.0V$	$\Delta V_{REF} \geq 3.0V$
			—	—	+1.5/-1.0	LSB	$V_{DD} = 5.0V$	
A06	EOFF	Offset Error	—	± 1	± 5	LSB	$V_{DD} = 3.0V$	$\Delta V_{REF} \geq 3.0V$
			—	—	± 3	LSB	$V_{DD} = 5.0V$	
A07	EGN	Gain Error	—	± 1	± 1.25	LSB	$V_{DD} = 3.0V$	$\Delta V_{REF} \geq 3.0V$
			—	—	± 2.00	LSB	$V_{DD} = 5.0V$	
A10	—	Monotonicity	Guaranteed ⁽¹⁾			—	$V_{SS} \leq V_{AIN} \leq V_{REF}$	
A20	ΔV_{REF}	Reference Voltage Range ($V_{REFH} - V_{REFL}$)	3	—	$V_{DD} - V_{SS}$	V	For 12-bit resolution	
A21	V_{REFH}	Reference Voltage High	$V_{SS} + 3.0V$	—	$V_{DD} + 0.3V$	V	For 12-bit resolution	
A22	V_{REFL}	Reference Voltage Low	$V_{SS} - 0.3V$	—	$V_{DD} - 3.0V$	V	For 12-bit resolution	
A25	V_{AIN}	Analog Input Voltage	V_{REFL}	—	V_{REFH}	V		
A30	Z_{AIN}	Recommended Impedance of Analog Voltage Source	—	—	2.5	k Ω		
A50	IREF	V_{REF} Input Current ⁽²⁾	—	—	5	μA	During V_{AIN} acquisition. During A/D conversion cycle.	
			—	—	150	μA		

Note 1: The A/D conversion result never decreases with an increase in the input voltage and has no missing codes.

- Note 2:** V_{REFH} current is from the RA3/AN3/ V_{REF+} pin or V_{DD} , whichever is selected as the V_{REFH} source.
 V_{REFL} current is from the RA2/AN2/ V_{REF-}/CV_{REF} pin or V_{SS} , whichever is selected as the V_{REFL} source.

PIC18F2458/2553/4458/4553

FIGURE 4-3: A/D CONVERSION TIMING

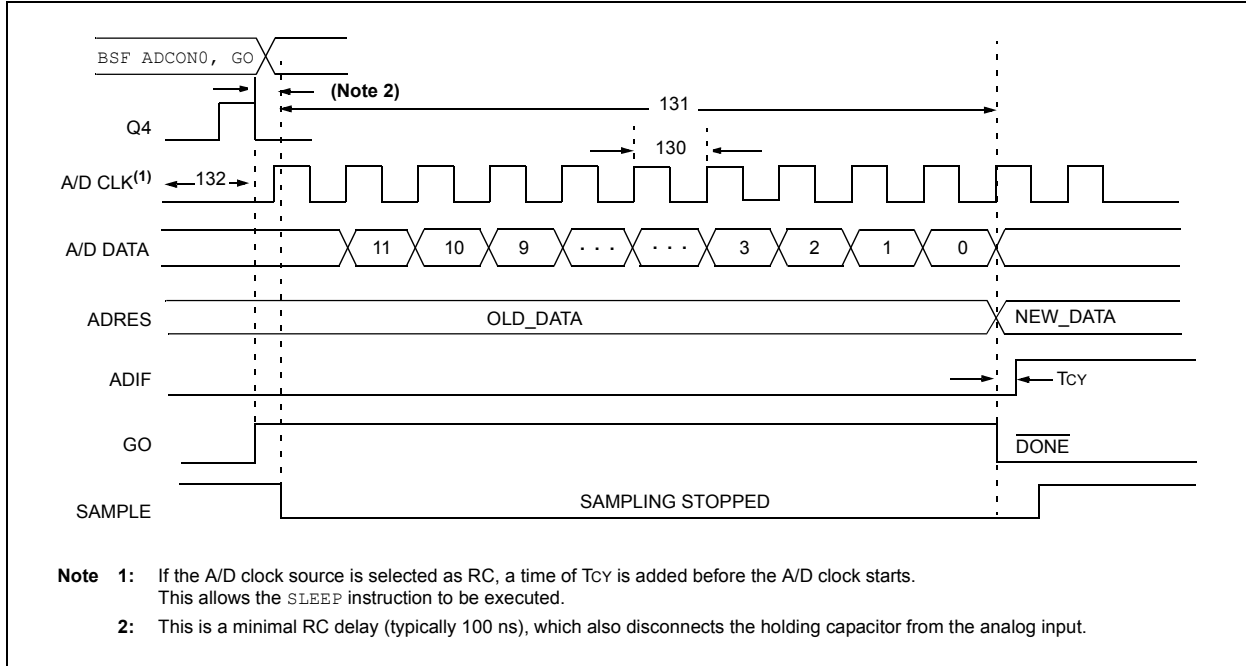

TABLE 4-2: A/D CONVERSION REQUIREMENTS

Param No.	Symbol	Characteristic	Min	Max	Units	Conditions	
130	TAD	A/D Clock Period	PIC18FXXXX	0.8	12.5 ⁽¹⁾	μS	TOSC based, VREF \geq 3.0V
			PIC18LFXXXX	1.4	25.0 ⁽¹⁾	μS	VDD = 3.0V; TOSC based, VREF full range
			PIC18FXXXX	—	1	μS	A/D RC mode
			PIC18LFXXXX	—	3	μS	VDD = 3.0V; A/D RC mode
131	T _{CV}	Conversion Time (not including acquisition time) ⁽²⁾	13	14	TAD		
132	T _{ACQ}	Acquisition Time ⁽³⁾	1.4	—	μS		
135	T _{SWC}	Switching Time from Convert \rightarrow Sample	—	(Note 4)			
137	T _{DIS}	Discharge Time	0.2	—	μS		

- Note 1:** The time of the A/D clock period is dependent on the device frequency and the TAD clock divider.
- Note 2:** ADRES registers may be read on the following T_{CY} cycle.
- Note 3:** The time for the holding capacitor to acquire the “New” input voltage when the voltage changes full scale after the conversion (VDD to VSS or VSS to VDD). The source impedance (R_S) on the input channels is 50 Ω .
- Note 4:** On the following cycle of the device clock.

5.0 PACKAGING INFORMATION

For packaging information, see the “*PIC18F2455/2550/4455/4550 Data Sheet*” (DS39632).

PIC18F2458/2553/4458/4553

NOTES:

PIC18F2458/2553/4458/4553

APPENDIX A: REVISION HISTORY

Revision A (May 2007)

Original data sheet for the PIC18F2458/2553/4458/4553 devices.

Revision B (June 2007)

Changes to Figure 4-2: PIC18LF2458/2553/4458/4553 Voltage-Frequency Graph (Industrial).

Revision C (October 2009)

Removed "Preliminary" marking.

APPENDIX B: DEVICE DIFFERENCES

The differences between the devices listed in this data sheet are shown in Table B-1.

TABLE B-1: DEVICE DIFFERENCES

Features	PIC18F2458	PIC18F2553	PIC18F4458	PIC18F4553
Program Memory (Bytes)	24576	32768	24576	32768
Program Memory (Instructions)	12288	16384	12288	16384
Interrupt Sources	19	19	20	20
I/O Ports	Ports A, B, C, (E)	Ports A, B, C, (E)	Ports A, B, C, D, E	Ports A, B, C, D, E
Capture/Compare/PWM Modules	2	2	1	1
Enhanced Capture/Compare/PWM Modules	0	0	1	1
Parallel Communications (SPP)	No	No	Yes	Yes
12-Bit Analog-to-Digital Module	10 Input Channels	10 Input Channels	13 Input Channels	13 Input Channels
Packages	28-Pin SPDIP 28-Pin SOIC	28-Pin SPDIP 28-Pin SOIC	40-Pin PDIP 44-Pin TQFP 44-Pin QFN	40-Pin PDIP 44-Pin TQFP 44-Pin QFN

PIC18F2458/2553/4458/4553

APPENDIX C: MIGRATION FROM MID-RANGE TO ENHANCED DEVICES

A detailed discussion of the differences between the mid-range MCU devices (i.e., PIC16CXXX) and the enhanced devices (i.e., PIC18FXXX) is provided in AN716, *"Migrating Designs from PIC16C74A/74B to PIC18C442"*. The changes discussed, while device specific, are generally applicable to all mid-range to enhanced device migrations.

This Application Note is available as Literature Number DS00716.

APPENDIX D: MIGRATION FROM HIGH-END TO ENHANCED DEVICES

A detailed discussion of the migration pathway and differences between the high-end MCU devices (i.e., PIC17CXXX) and the enhanced devices (i.e., PIC18FXXX) is provided in AN726, *"PIC17CXXX to PIC18CXXX Migration"*.

This Application Note is available as Literature Number DS00726.

INDEX

A

A/D	21
A/D Converter Interrupt, Configuring	25
Acquisition Requirements	26
ADCON0 Register	21
ADCON1 Register	21
ADCON2 Register	21
ADRESH Register	21, 24
ADRESL Register	21
Analog Port Pins, Configuring	28
Associated Registers	30
Calculating the Minimum Required Acquisition Time	26
Configuring the Module	25
Conversion Clock (TAD)	27
Conversion Status (GO/DONE Bit)	24
Conversions	29
Converter Characteristics	35
Discharge	29
Operation in Power-Managed Modes	28
Selecting and Configuring Acquisition Time	27
Special Event Trigger (CCP)	30
Use of the CCP2 Trigger	30
Absolute Maximum Ratings	33
ADCON0 Register	21
GO/DONE Bit	24
ADCON1 Register	21
ADCON2 Register	21
ADRESH Register	21
ADRESL Register	21, 24
Analog-to-Digital Converter. <i>See</i> A/D.	

B

Block Diagrams	
A/D	24
Analog Input Model	25
PIC18F2458/2553	9
PIC18F4458/4553	10

C

Compare (CCP Module)	
Special Event Trigger	30
Customer Change Notification Service	43
Customer Notification Service	43
Customer Support	43

D

Device Differences	39
Device ID Registers	31
Device Overview	7
Other Special Features	7

E

Electrical Characteristics	33
Equations	
A/D Acquisition Time	26
A/D Minimum Charging Time	26
Errata	6

I

Internet Address	43
Interrupt Sources	
A/D Conversion Complete	25

M

Microchip Internet Web Site	43
Migration from High-End to Enhanced Devices	40
Migration from Mid-Range to Enhanced Devices	40

P

Packaging Information	37
Pin Functions	
MCLR/VPP/RE3	11
MCLR/VPP/RE3	15
NC/ICCK/ICPGC	20
NC/ICDT/ICPGD	20
NC/ICPORTS	20
NC/ICRST/ICVPP	20
OSC1/CLKI	11, 15
OSC2/CLKO/RA6	11, 15
RA0/AN0	12, 16
RA1/AN1	12, 16
RA2/AN2/VREF-/CVREF	12, 16
RA3/AN3/VREF+	12, 16
RA4/T0CKI/C1OUT/RCV	12, 16
RA5/AN4/SS/HLVDIN/C2OUT	12, 16
RB0/AN12/INT0/FLT0/SDI/SDA	13, 17
RB1/AN10/INT1/SCK/SCL	13, 17
RB2/AN8/INT2/VMO	13, 17
RB3/AN9/CCP2/VPO	13, 17
RB4/AN11/KBI0	13
RB4/AN11/KBI0/CSSPP	17
RB5/KBI1/PGM	13, 17
RB6/KBI2/PGC	13, 17
RB7/KBI3/PGD	13, 17
RC0/T1OSO/T13CKI	14, 18
RC1/T1OSI/CCP2/UOE	14, 18
RC2/CCP1	14
RC2/CCP1/P1A	18
RC4/D-/VM	14, 18
RC5/D+/VP	14, 18
RC6/TX/CK	14, 18
RC7/RX/DT/SDO	14, 18
RD0/SPP0	19
RD1/SPP1	19
RD2/SPP2	19
RD3/SPP3	19
RD4/SPP4	19
RD5/SPP5/P1B	19
RD6/SPP6/P1C	19
RD7/SPP7/P1D	19
RE0/AN5/CK1SPP	20
RE1/AN6/CK2SPP	20
RE2/AN7/OESPP	20
VDD	14, 20
VSS	14, 20
VUSB	14, 20
Pinout I/O Descriptions	
PIC18F2458/2553	11
PIC18F4458/4553	15
Power-Managed Modes	
and A/D Operation	28

R

Reader Response	44
Registers	
ADCON0 (A/D Control 0)	21

PIC18F2458/2553/4458/4553

ADCON1 (A/D Control 1)	22
ADCON2 (A/D Control 2)	23
DEVID1 (Device ID 1)	32
DEVID2 (Device ID 2)	32
Revision History	39

S

Special Features of the CPU	31
-----------------------------------	----

T

Timing Diagrams	
A/D Conversion	36
Timing Diagrams and Specifications	
A/D Conversion Requirements	36

W

WWW Address	43
WWW, On-Line Support	6

THE MICROCHIP WEB SITE

Microchip provides online support via our WWW site at www.microchip.com. This web site is used as a means to make files and information easily available to customers. Accessible by using your favorite Internet browser, the web site contains the following information:

- **Product Support** – Data sheets and errata, application notes and sample programs, design resources, user's guides and hardware support documents, latest software releases and archived software
- **General Technical Support** – Frequently Asked Questions (FAQ), technical support requests, online discussion groups, Microchip consultant program member listing
- **Business of Microchip** – Product selector and ordering guides, latest Microchip press releases, listing of seminars and events, listings of Microchip sales offices, distributors and factory representatives

CUSTOMER CHANGE NOTIFICATION SERVICE

Microchip's customer notification service helps keep customers current on Microchip products. Subscribers will receive e-mail notification whenever there are changes, updates, revisions or errata related to a specified product family or development tool of interest.

To register, access the Microchip web site at www.microchip.com, click on Customer Change Notification and follow the registration instructions.

CUSTOMER SUPPORT

Users of Microchip products can receive assistance through several channels:

- Distributor or Representative
- Local Sales Office
- Field Application Engineer (FAE)
- Technical Support
- Development Systems Information Line

Customers should contact their distributor, representative or field application engineer (FAE) for support. Local sales offices are also available to help customers. A listing of sales offices and locations is included in the back of this document.

Technical support is available through the web site at: <http://support.microchip.com>

PIC18F2458/2553/4458/4553

READER RESPONSE

It is our intention to provide you with the best documentation possible to ensure successful use of your Microchip product. If you wish to provide your comments on organization, clarity, subject matter, and ways in which our documentation can better serve you, please FAX your comments to the Technical Publications Manager at (480) 792-4150.

Please list the following information, and use this outline to provide us with your comments about this document.

To: Technical Publications Manager
RE: Reader Response
From: Name _____
Company _____
Address _____
City / State / ZIP / Country _____
Telephone: (_____) _____ - _____ FAX: (_____) _____ - _____

Application (optional):

Would you like a reply? ___Y ___N

Device: PIC18F2458/2553/4458/4553 Literature Number: DS39887C

Questions:

1. What are the best features of this document?

2. How does this document meet your hardware and software development needs?

3. Do you find the organization of this document easy to follow? If not, why?

4. What additions to the document do you think would enhance the structure and subject?

5. What deletions from the document could be made without affecting the overall usefulness?

6. Is there any incorrect or misleading information (what and where)?

7. How would you improve this document?

PIC18F2458/2553/4458/4553

PRODUCT IDENTIFICATION SYSTEM

To order or obtain information, e.g., on pricing or delivery, refer to the factory or the listed sales office.

<u>PART NO.</u>	<u>X</u>	<u>/XX</u>	<u>XXX</u>
Device	Temperature Range	Package	Pattern
Device	PIC18F2458/2553 ⁽¹⁾ , PIC18F4458/4553 ⁽¹⁾ , PIC18F2458/2553T ⁽²⁾ , PIC18F4458/4553T ⁽²⁾ ; V _{DD} range 4.2V to 5.5V PIC18LF2458/2553 ⁽¹⁾ , PIC18LF4458/4553 ⁽¹⁾ , PIC18LF2458/2553T ⁽²⁾ , PIC18LF4458/4553T ⁽²⁾ ; V _{DD} range 2.0V to 5.5V		
Temperature Range	I = -40°C to +85°C (Industrial) E = -40°C to +125°C (Extended)		
Package	PT = TQFP (Thin Quad Flatpack) SO = SOIC SP = Skinny PDIP P = PDIP ML = QFN		
Pattern	QTP, SQTP, Code or Special Requirements (blank otherwise)		

Examples:

- a) PIC18LF4553-I/P 301 = Industrial temp., PDIP package, Extended V_{DD} limits, QTP pattern #301.
- b) PIC18LF2458-I/SO = Industrial temp., SOIC package, Extended V_{DD} limits.
- c) PIC18F4458-I/P = Industrial temp., PDIP package, normal V_{DD} limits.

Note 1: F = Standard Voltage Range
 LF = Wide Voltage Range
2: T = In tape and reel TQFP packages only.



WORLDWIDE SALES AND SERVICE

AMERICAS

Corporate Office
2355 West Chandler Blvd.
Chandler, AZ 85224-6199
Tel: 480-792-7200
Fax: 480-792-7277
Technical Support:
<http://support.microchip.com>
Web Address:
www.microchip.com

Atlanta
Duluth, GA
Tel: 678-957-9614
Fax: 678-957-1455

Boston
Westborough, MA
Tel: 774-760-0087
Fax: 774-760-0088

Chicago
Itasca, IL
Tel: 630-285-0071
Fax: 630-285-0075

Cleveland
Independence, OH
Tel: 216-447-0464
Fax: 216-447-0643

Dallas
Addison, TX
Tel: 972-818-7423
Fax: 972-818-2924

Detroit
Farmington Hills, MI
Tel: 248-538-2250
Fax: 248-538-2260

Kokomo
Kokomo, IN
Tel: 765-864-8360
Fax: 765-864-8387

Los Angeles
Mission Viejo, CA
Tel: 949-462-9523
Fax: 949-462-9608

Santa Clara
Santa Clara, CA
Tel: 408-961-6444
Fax: 408-961-6445

Toronto
Mississauga, Ontario,
Canada
Tel: 905-673-0699
Fax: 905-673-6509

ASIA/PACIFIC

Asia Pacific Office
Suites 3707-14, 37th Floor
Tower 6, The Gateway
Harbour City, Kowloon
Hong Kong
Tel: 852-2401-1200
Fax: 852-2401-3431

Australia - Sydney
Tel: 61-2-9868-6733
Fax: 61-2-9868-6755

China - Beijing
Tel: 86-10-8528-2100
Fax: 86-10-8528-2104

China - Chengdu
Tel: 86-28-8665-5511
Fax: 86-28-8665-7889

China - Hong Kong SAR
Tel: 852-2401-1200
Fax: 852-2401-3431

China - Nanjing
Tel: 86-25-8473-2460
Fax: 86-25-8473-2470

China - Qingdao
Tel: 86-532-8502-7355
Fax: 86-532-8502-7205

China - Shanghai
Tel: 86-21-5407-5533
Fax: 86-21-5407-5066

China - Shenyang
Tel: 86-24-2334-2829
Fax: 86-24-2334-2393

China - Shenzhen
Tel: 86-755-8203-2660
Fax: 86-755-8203-1760

China - Wuhan
Tel: 86-27-5980-5300
Fax: 86-27-5980-5118

China - Xiamen
Tel: 86-592-2388138
Fax: 86-592-2388130

China - Xian
Tel: 86-29-8833-7252
Fax: 86-29-8833-7256

China - Zhuhai
Tel: 86-756-3210040
Fax: 86-756-3210049

ASIA/PACIFIC

India - Bangalore
Tel: 91-80-3090-4444
Fax: 91-80-3090-4080

India - New Delhi
Tel: 91-11-4160-8631
Fax: 91-11-4160-8632

India - Pune
Tel: 91-20-2566-1512
Fax: 91-20-2566-1513

Japan - Yokohama
Tel: 81-45-471- 6166
Fax: 81-45-471-6122

Korea - Daegu
Tel: 82-53-744-4301
Fax: 82-53-744-4302

Korea - Seoul
Tel: 82-2-554-7200
Fax: 82-2-558-5932 or
82-2-558-5934

Malaysia - Kuala Lumpur
Tel: 60-3-6201-9857
Fax: 60-3-6201-9859

Malaysia - Penang
Tel: 60-4-227-8870
Fax: 60-4-227-4068

Philippines - Manila
Tel: 63-2-634-9065
Fax: 63-2-634-9069

Singapore
Tel: 65-6334-8870
Fax: 65-6334-8850

Taiwan - Hsin Chu
Tel: 886-3-6578-300
Fax: 886-3-6578-370

Taiwan - Kaohsiung
Tel: 886-7-536-4818
Fax: 886-7-536-4803

Taiwan - Taipei
Tel: 886-2-2500-6610
Fax: 886-2-2508-0102

Thailand - Bangkok
Tel: 66-2-694-1351
Fax: 66-2-694-1350

EUROPE

Austria - Wels
Tel: 43-7242-2244-39
Fax: 43-7242-2244-393

Denmark - Copenhagen
Tel: 45-4450-2828
Fax: 45-4485-2829

France - Paris
Tel: 33-1-69-53-63-20
Fax: 33-1-69-30-90-79

Germany - Munich
Tel: 49-89-627-144-0
Fax: 49-89-627-144-44

Italy - Milan
Tel: 39-0331-742611
Fax: 39-0331-466781

Netherlands - Drunen
Tel: 31-416-690399
Fax: 31-416-690340



Spain - Madrid
Tel: 34-91-708-08-90
Fax: 34-91-708-08-91

UK - Wokingham
Tel: 44-118-921-5869
Fax: 44-118-921-5820

03/26/09

Looking for pricing, stock, or lifecycle information?

Click below to explore more details on WIN SOURCE:

-  [View PIC18LF4553-I/ML on WIN SOURCE](#)
-  [Microchip Technology](#) Information

Optimize Your Supply Chain with WIN SOURCE Solutions

-  Global Sourcing Solution
-  Obsolete Management
-  Cost Control Management
-  Shortage Management
-  Alternative Solution
-  Excess Inventory Management