



**THE DATASHEET OF
PT8A3516BPE**



Smart Iron Controller

Features

- Build in RC oscillator for sensor signal detection
- On chip shunt regulated power supply
- Using AC 60Hz/50Hz as timer clock can select by Part No.
- Accurate timer with error dropping in $\pm 1\%$
- Sensitive movement detection
- Powerful immunity of sensor Vibration
- 30s time out for IRON in static horizontal position
- 8min/10min/15min time out for IRON in static vertical position
- LED to indicate operation status
- Usable in both 120V and 240V voltage supply system
- Quick function test mode
- Support buzzer
- Few external components
- System standby mode power dissipation less than 1W (:s)
- DIP-8 and SOIC-8 package
- Patent No: ZL 2005 2 0048330.4

Applications

- Electric Iron Controller

Description

The PT8A3514/15/16/17/18/19(A/B) are high performance low power and low cost CMOS chips designed for intelligent electric IRON controller. Their intelligence mainly results from their sensitive detection to the movement and static position of electric iron by using a special sensor. With the sensor, these chips can detect the vertical/horizontal position and movement status of IRON.

These chips are equipped with on-chip shunt regulator, sensor signal processor, build-in oscillator, timer, logic control, power on reset and output driving block etc.

Pin Assignment

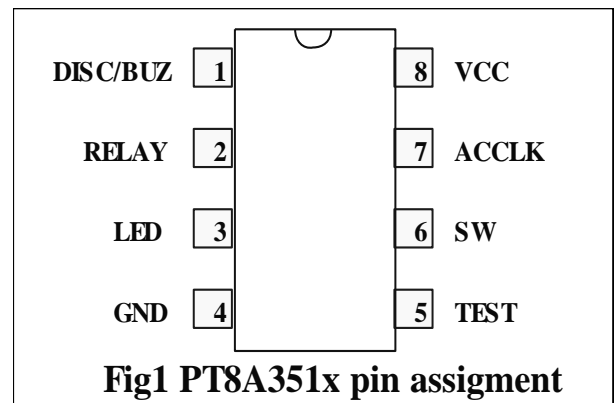

Pad Description

Pin No.	Pin Name	I/O	Description
1	DISC/BUZ	O	Discharge the external electrolytic cap to stabilize and limit its voltage. Output 4KHz to driver buzzer when timer is out. Active high.
2	RELAY	O	Relay drive output, active high.
3	LED	O	With open drain output, it can shut off external LED in parallel with this open-drain transistor, active low.
4	GND	-	Ground.
5	TEST	I	Low for test mode*.
6	SW	I	Sensor signal input, input high will be considered horizontal.
7	ACCLK	I	AC 60/50Hz signal for clock with Schmitt architecture, internal drop down.
8	VCC	-	Power supply.

*Note: Teat mode comparison table:

Real timer	30s	8m	10m	15m
Test timer	3s	9.6s	9.6s	12s

Block Diagram

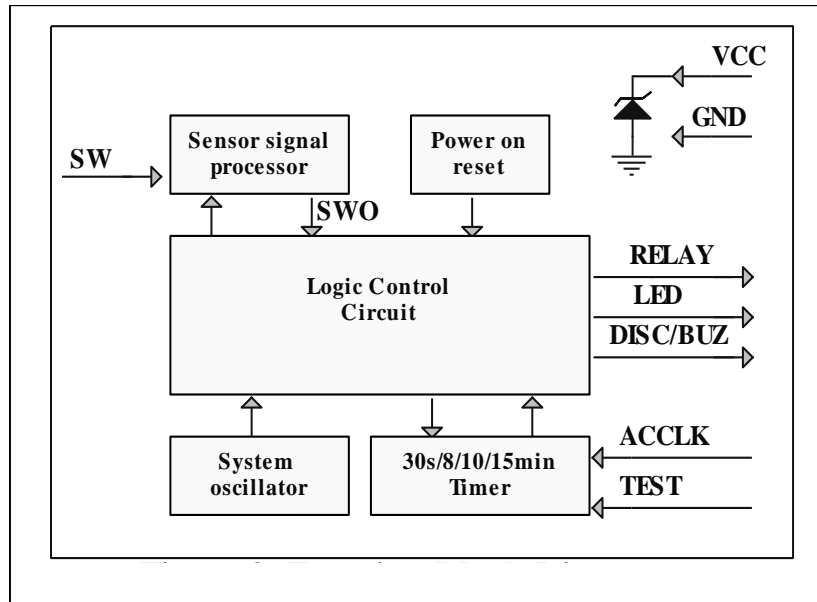

Maximum Ratings

Storage Temperature.....	- 40°C to +125°C
Supply Voltage to Ground Potential (Inputs & V _{CC} only).....	- 0.5 to V _{CC} +0.5V
Supply Voltage to Ground Potential (Outputs & D/O only)....	- 0.5 to V _{CC} +0.5V
DC Input Voltage	- 0.5V to V _{CC} +0.5V
DC Output Current20mA
Power Dissipation.....	..500mW

Note:

Stresses greater than those listed under MAXIMUM RATINGS may cause permanent damage to the device. This is a stress rating only and functional operation of the device at these or any other conditions above those indicated in the operational sections of this specification is not implied. Exposure to absolute maximum rating conditions for extended periods may affect reliability.

Recommended Operating Conditions

Symbol	Description	Min	Typical	Max	Unit
V _{CC}	Supply voltage	4.5	5	5.5	V
T _A	Operating Temperature	-10	25	85	°C

Electrical Characteristics (T_A = -10 ~ 85 °C, unless otherwise noted)

Sym	Parameter	Test Conditions		Min	Typ	Max	Unit
		V _{CC}	Condition				
V _{CC}	Internal Shunt regulator voltage	-	-	4.5	5	5.5	V
I _{IL1}	Input low current(ACCLK)	5V	V _{IL} =0V	-	-	-1	μA
I _{IL2}	Input low current(TEST)	5V	V _{IL} =0V	-5	-	-30	μA
I _{IL3}	Input low current(SW)	5V	V _{IL} =0V	-	-	-1	μA
I _{IH1}	Input high current(ACCLK)	5V	V _{IH} =5V	30	-	100	μA
I _{IH2}	Input high current(ACSEL)	5V	V _{IH} =5V	-	-	30	μA
I _{IH3}	Input high current(SW)	5V	V _{IH} =5V	-	-	1	μA
I _{OH1}	Output Source Current (RELAY /DISC)	5V	V _{OH1} =2.5V	-0.3	-	-0.7	mA
I _{OL1}	Output Sink Current (RELAY /DISC)	5V	V _{OL1} =0.5V	5	-	-	mA
I _{OL2}	Output Sink Current (LED)	5V	V _{OL2} =0.5V	10	-	-	mA
I _{CC}	Power supply current	4V	See Figure3	-	-	400	μA

Functional Description (Refer to *Block Diagram*)

The chip is comprised of several blocks: on-chip shunt regulator, sensor signal processor, build-in system oscillator, 30s/8min/10min/15min timer, logic control circuit, and power on reset, etc. Each block will be described as below.

Logic control circuit

Logic control circuit mainly carries out logic control function. It not only collects signals from other blocks, but also generates various driving signals including RELAY&DISC. Besides, an external LED will flash at about 1Hz and a buzzer will make a sound with a frequency of 4KHz every 0.5s for 6 times or continual after internal timer times out. Signals at RELAY will control external relay to decide whether IRON heats or not.

Sensor signal processor

The core in the whole system is how to correctly detect the position and movement of sensor so that the system can be always under safe control. Thus, it is critical to accurately and correctly deal with signal from sensor in different status and eliminate the noise caused by debounce action from sensor. Here, a unique structure is used to do the high-requirement signal processing.

In real application of IRON, sensor needs to be installed according to certain requirements (for example its inclination).

Timer

Timer block mainly generates various timing signal according to the position of IRON.

It is easy to get accurate timer (30s/8min/10min/15min) by using AC 60Hz/50Hz signal as timing reference. As above description, Iron in Horizontal position over 30s will stop heating. While Iron in vertical position over 8min/10min/ 15min will also stop heating.

Buzzer

A buzzer will make 0.5S sound with a frequency of 4 KHz for 6 times or continual after internal timer timeouts.

LED

During heating, LED pin is floating and an external LED will turn on. After times out, LED pin outputs pulse and an external LED will flash at about 1Hz.

Application Circuit

Note: Suggest the parameters of relay meet the following specification: 24VDC, 1.6K Ω Coil resistance

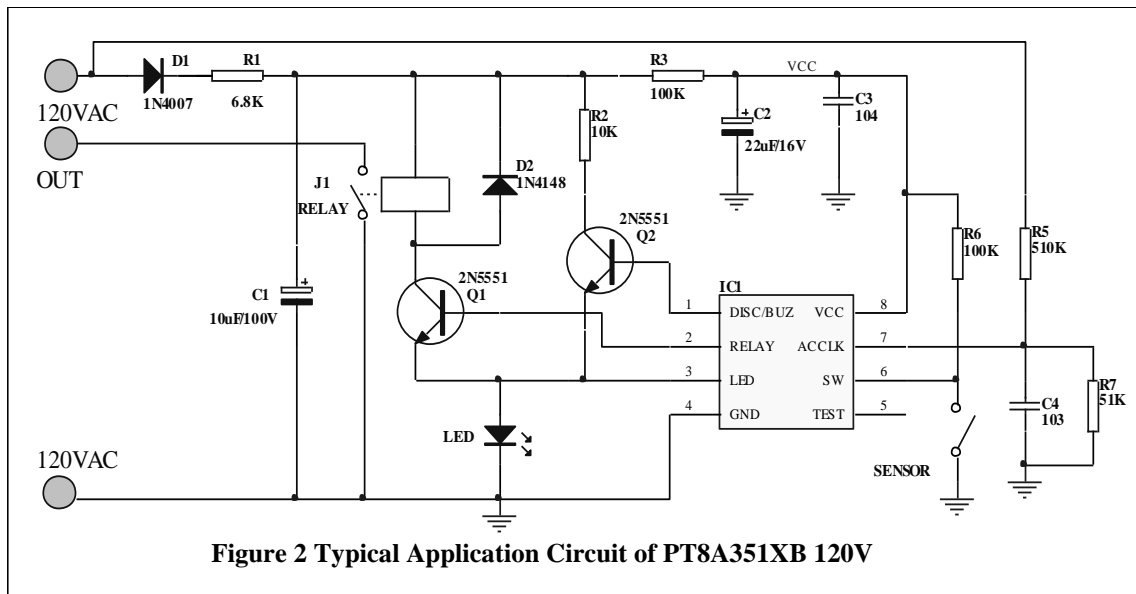
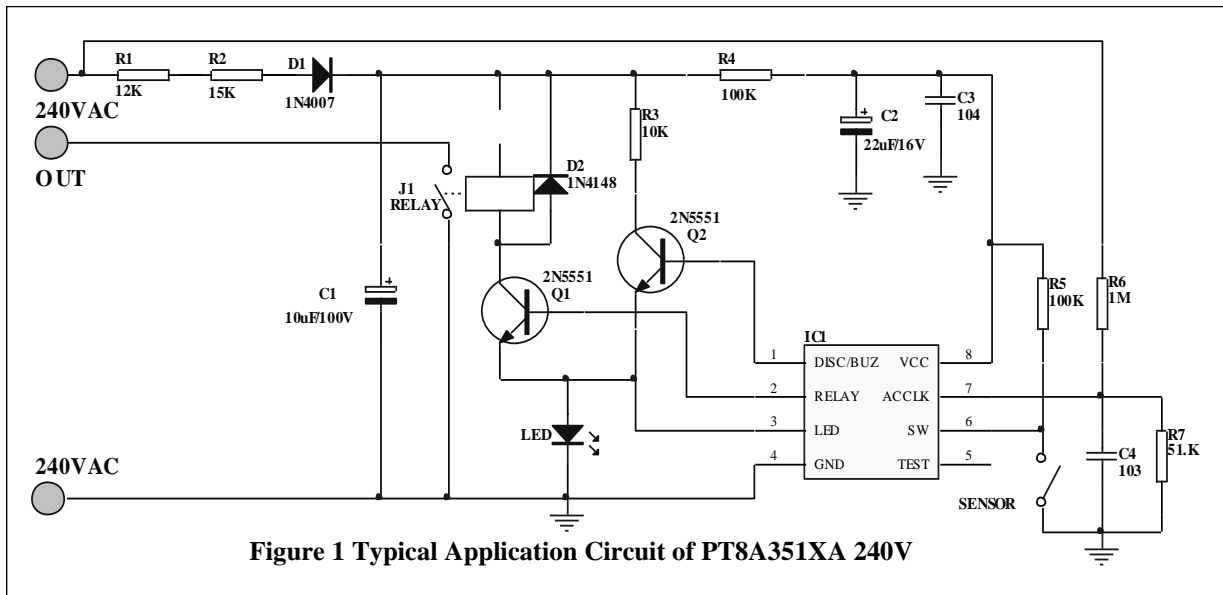

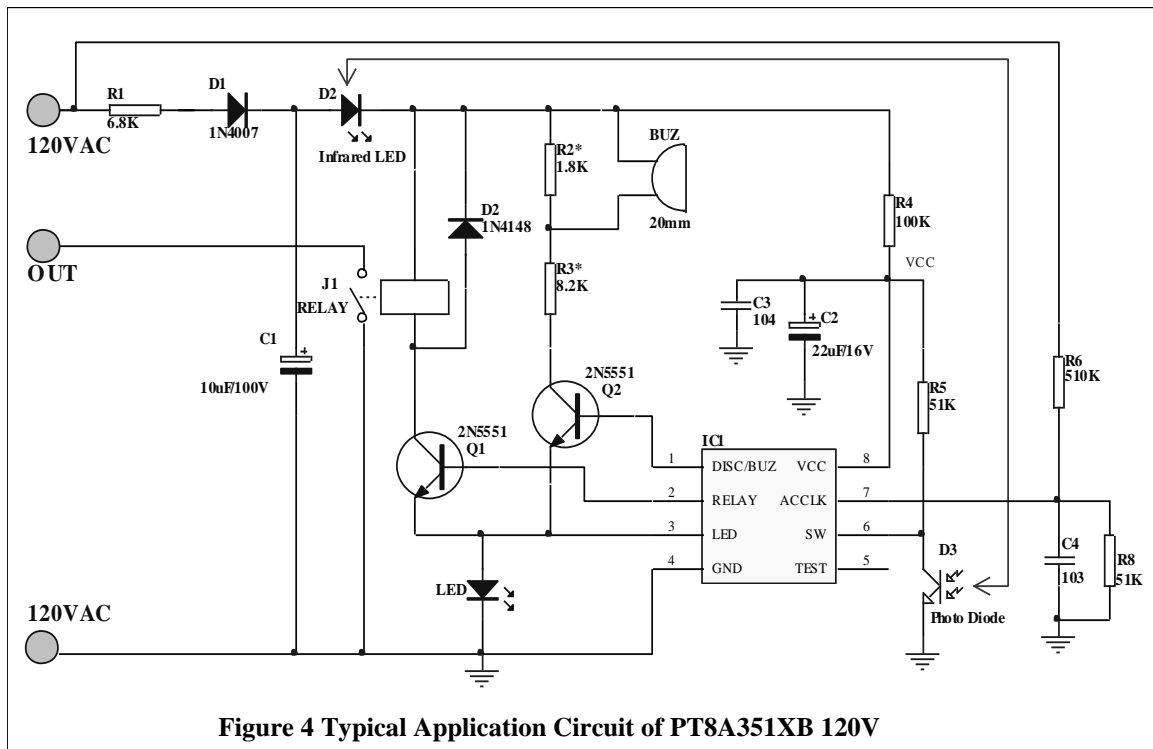
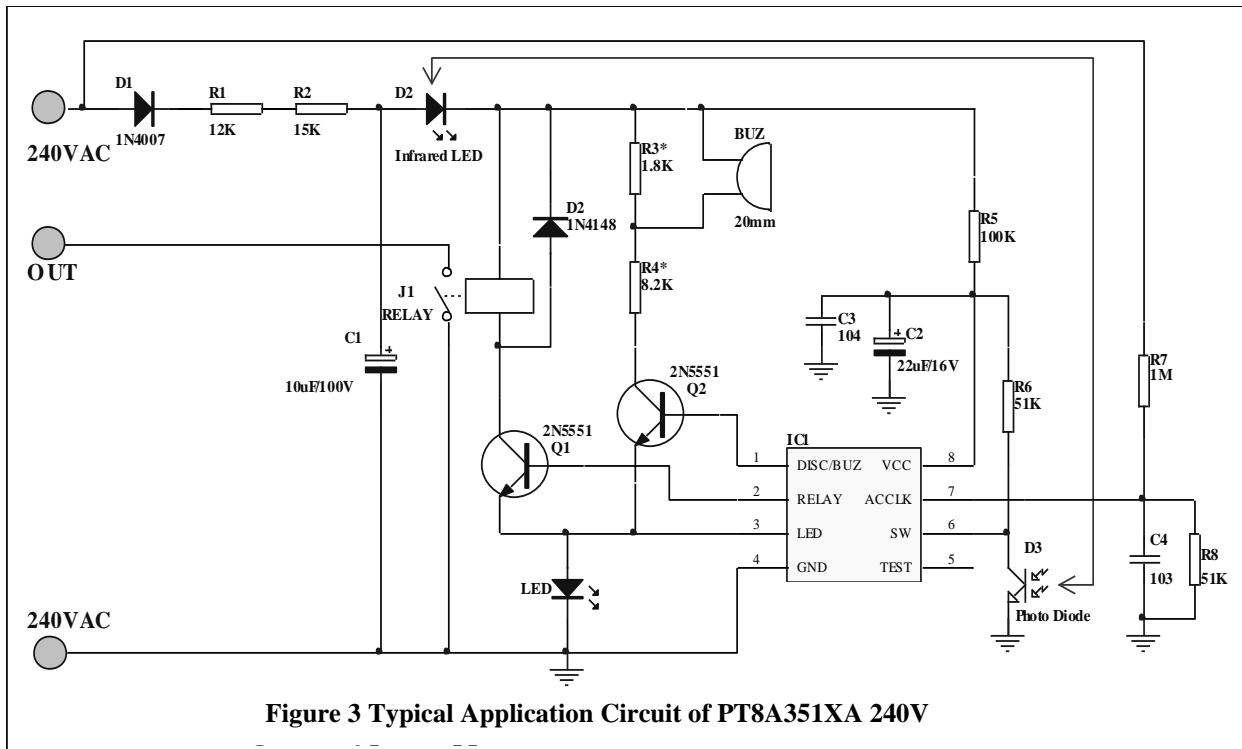

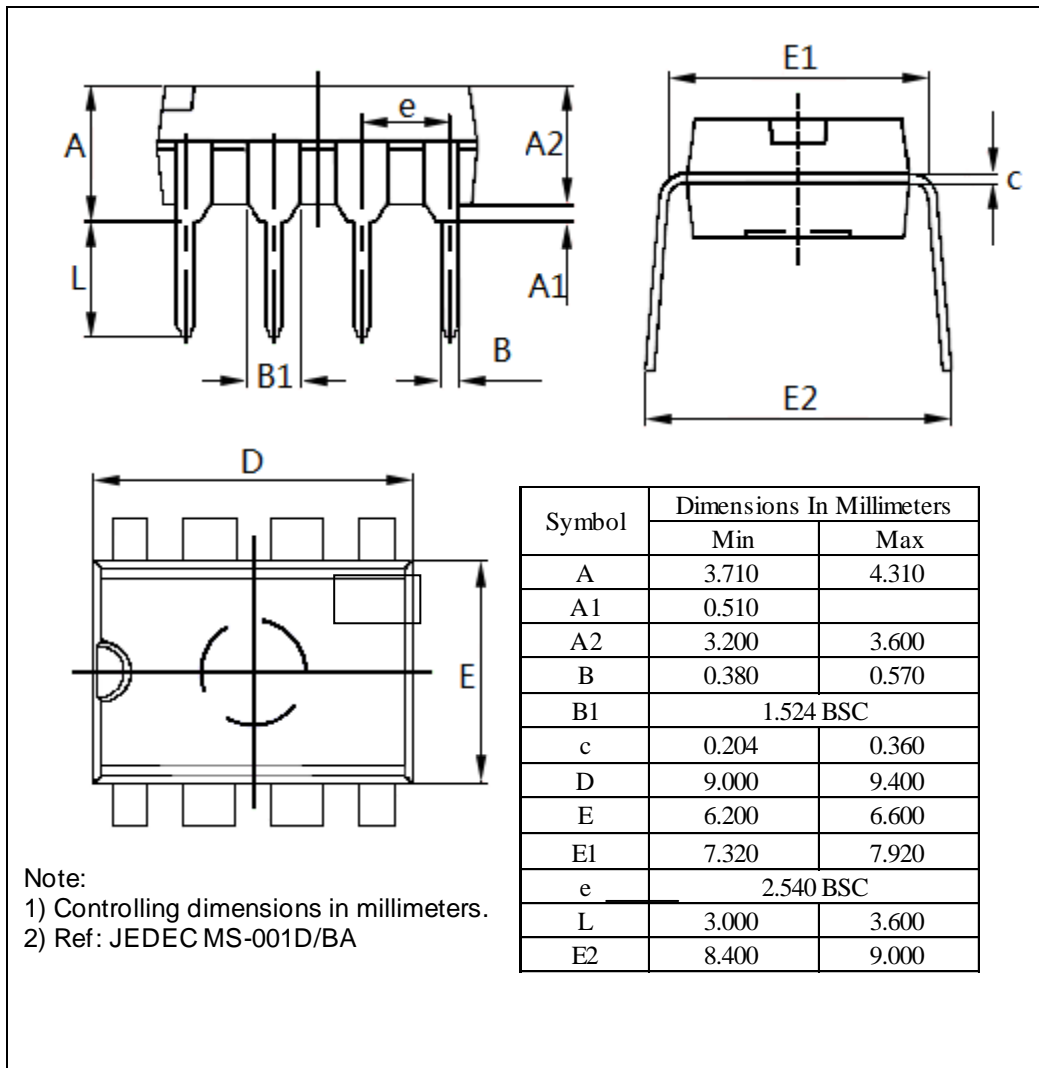
Mechanical Information
PE (DIP-8)

WE (SOIC-8)

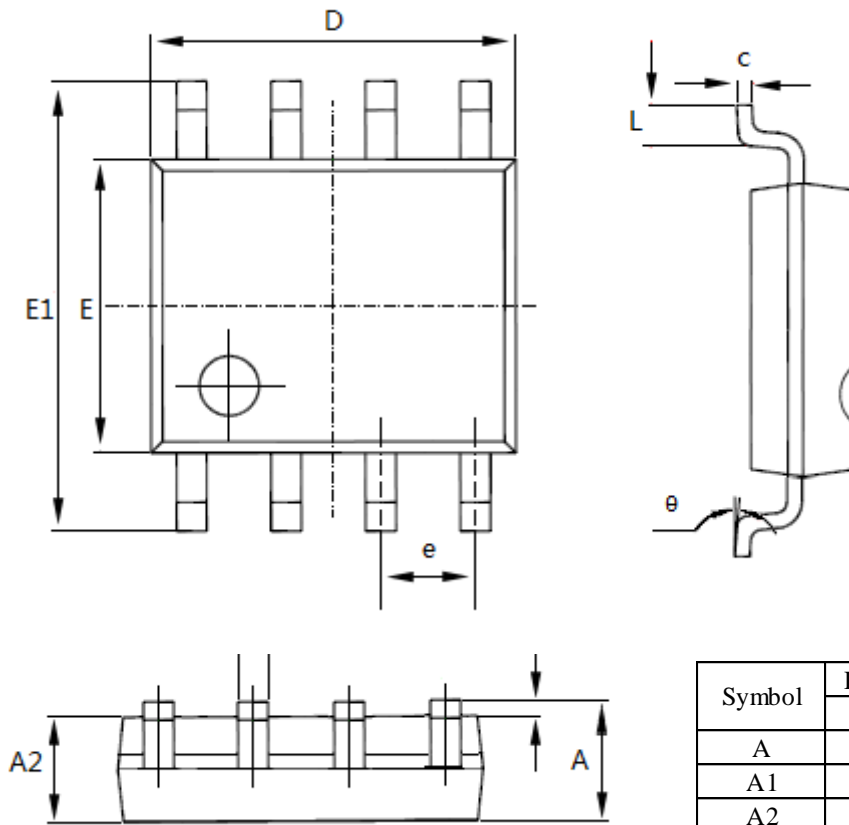

Note:
1) Controlling dimensions in millimeters.
2) Ref: JEDEC MS-012E/AA

Symbol	Dimensions In Millimeters	
	Min	Max
A	1.350	1.750
A1	0.100	0.250
A2	1.350	1.550
b	0.330	0.510
c	0.170	0.250
D	4.700	5.100
E	3.800	4.000
E1	5.800	6.200
e	1.27 BSC	
L	0.400	1.270
θ	0°	8°

Ordering Information

Part Number	Package Code	Package
PT8A351xAPE	P	Lead free DIP-8
PT8A351xBPE	P	Lead free DIP-8
PT8A351xAWE	W	Lead free and Green SOIC-8
PT8A351xBWE	W	Lead free and Green SOIC-8

Note:

- See below *Function comparison table* for details.
- E = Pb-free or Pb-free & Green
- Adding X Suffix= Tape/Reel

Function comparison table



Part Number	Frequency	Vertical Timer	Horizontal timer	Buzzer
PT8A 3514A	50Hz	10min	30s	Continual
PT8A 3515A	50Hz	8min	30s	Stop after 6 times
PT8A 3516A	50Hz	15min	30s	Stop after 6 times
PT8A 3517A	50Hz	8min	30s	Continual
PT8A 3518A	50Hz	15min	30s	Continual
PT8A 3519A	50Hz	10min	30s	Stop after 6 times
PT8A 3514B	60Hz	10min	30s	Continual
PT8A 3515B	60Hz	8min	30s	Stop after 6 times
PT8A 3516B	60Hz	15min	30s	Stop after 6 times
PT8A 3517B	60Hz	8min	30s	Continual
PT8A 3518B	60Hz	15min	30s	Continual
PT8A 3519B	60Hz	10min	30s	Stop after 6 times

Pericom Semiconductor Corporation • 1-800-435-2336 • www.pericom.com







Pericom reserves the right to make changes to its products or specifications at any time, without notice, in order to improve design or performance and to supply the best possible product. Pericom does not assume any responsibility for use of any circuitry described other than the circuitry embodied in Pericom product. The company makes no representations that circuitry described herein is free from patent infringement or other rights, of Pericom.

Looking for pricing, stock, or lifecycle information?

Click below to explore more details on WIN SOURCE:

-  [View PT8A3516BPE on WIN SOURCE](#)
-  [Diodes Incorporated Information](#)

Optimize Your Supply Chain with WIN SOURCE Solutions

-  Global Sourcing Solution
-  Obsolete Management
-  Cost Control Management
-  Shortage Management
-  Alternative Solution
-  Excess Inventory Management