



**THE DATASHEET OF
TS317CW RPG**



TMP100-Q1 and TMP101-Q1 Temperature Sensor With I²C and SMBus Interface with Alert Function in SOT-23 Package

1 Features

- AEC-Q100 qualified with the following results:
 - Temperature grade 1: –55°C to +125°C operating temperature range
 - HBM ESD component classification level 2
 - CDM ESD component classification level C5
- Functional Safety-Capable
 - Documentation available to aid functional safety system design
- Digital output: SMBus™, two-wire, and I²C interface compatibility
- Resolution: 9 to 12 bits, user-selectable
- Accuracy:
 - ±1°C (typical) from –55°C to 125°C
 - ±2°C (maximum) from –55°C to 125°C
- Low quiescent current: 45-µA, 0.1-µA standby
- Wide supply range: 2.7 V to 5.5 V
- TMP100-Q1 features two address pins
- TMP101-Q1 features one address pin and an ALERT pin
- 6-pin SOT-23 package

2 Applications

- Power-supply temperature monitoring
- Battery management
- Thermostat controls
- Automotive:
 - Head unit
 - Cluster
 - Body electronics
 - Lighting

3 Description

The TMP100-Q1 and TMP101-Q1 devices are digital temperature sensors designed for negative temperature coefficient (NTC) and positive temperature coefficient (PTC) thermistor replacement. The devices offer a typical accuracy of ±1°C without requiring calibration or external component signal conditioning. Device temperature sensors are highly linear and do not require complex calculations or look-up tables to derive the temperature. The on-chip, 12-bit ADC offers resolutions down to 0.0625°C. The devices are available in 6-Pin SOT-23 packages.

The TMP100-Q1 and TMP101-Q1 devices feature SMBus, Two-Wire, and I²C interface compatibility. The TMP100-Q1 device allows up to eight devices on one bus. The TMP101-Q1 device offers an SMBus Alert function with up to three devices per bus.

The TMP100-Q1 and TMP101-Q1 devices are designed for extended temperature measurement in a variety of communication, computer, consumer, environmental, industrial, and instrumentation applications.

The TMP100-Q1 and TMP101-Q1 devices are specified for operation over a temperature range of –55°C to 125°C.

Device Information⁽¹⁾

PART NUMBER	PACKAGE	BODY SIZE (NOM)
TMP100-Q1	SOT-23 (6)	2.90 mm × 1.60 mm
TMP101-Q1	SOT-23 (6)	2.90 mm × 1.60 mm

(1) For all available packages, see the orderable addendum at the end of the data sheet.

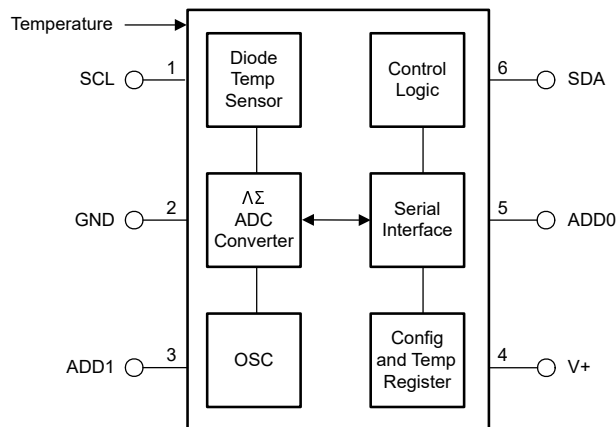

TMP100-Q1 Block Diagram

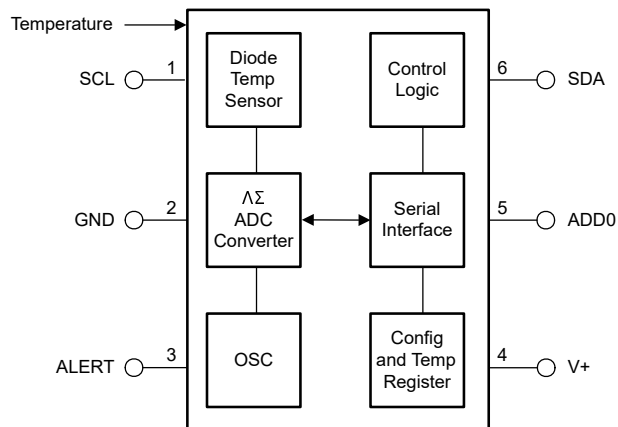

TMP101-Q1 Block Diagram



Table of Contents

1 Features	1	7.4 Device Functional Modes.....	14
2 Applications	1	7.5 Programming.....	14
3 Description	1	8 Application and Implementation	19
4 Revision History	2	8.1 Application Information.....	19
5 Pin Configuration and Functions	3	8.2 Typical Application.....	19
6 Specifications	4	9 Power Supply Recommendations	20
6.1 Absolute Maximum Ratings.....	4	10 Layout	21
6.2 ESD Ratings.....	4	10.1 Layout Guidelines.....	21
6.3 Recommended Operating Conditions.....	4	10.2 Layout Examples.....	21
6.4 Thermal Information.....	4	11 Device and Documentation Support	23
6.5 Electrical Characteristics.....	5	11.1 Receiving Notification of Documentation Updates..	23
6.6 Timing Requirements.....	6	11.2 Support Resources.....	23
6.7 Typical Characteristics.....	7	11.3 Trademarks.....	23
7 Detailed Description	8	11.4 Electrostatic Discharge Caution.....	23
7.1 Overview.....	8	11.5 Glossary.....	23
7.2 Functional Block Diagram.....	8	12 Mechanical, Packaging, and Orderable Information	23
7.3 Feature Description.....	9		

4 Revision History

Changes from Revision A (May 2017) to Revision B (June 2022) Page

- Updated the numbering format for tables, figures, and cross-references throughout the document..... 1
- Added Functional Safety information to the *Features* section..... 1

Changes from Revision * (September 2011) to Revision A (May 2017) Page

- Added the *Device Information* table, *Pin Configuration and Functions* section, *Handling Ratings* table, *Timing Requirements* table, *Switching Characteristics* table, *Feature Description* section, *Device Functional Modes* section, *Application and Implementation* section, *Power Supply Recommendations* section, *Layout* section, *Device and Documentation Support* section, and *Mechanical, Packaging, and Orderable Information* section 1

6 Specifications

6.1 Absolute Maximum Ratings

over operating free-air temperature range (unless otherwise noted)⁽¹⁾

	MIN	MAX	UNIT
Power supply, V+		7.5	V
Input voltage ⁽²⁾	-0.5	7.5	V
Operating temperature	-55	125	°C
Junction temperature, T _J		150	°C
Storage temperature, T _{stg}	-60	150	°C

- (1) Stresses beyond those listed under *Absolute Maximum Ratings* may cause permanent damage to the device. These are stress ratings only, which do not imply functional operation of the device at these or any other conditions beyond those indicated under *Recommended Operating Conditions*. Exposure to absolute-maximum-rated conditions for extended periods may affect device reliability.
- (2) Input voltage rating applies to all TMP100-Q1 and TMP101-Q1 input voltages.

6.2 ESD Ratings

		VALUE	UNIT
V _(ESD)	Electrostatic discharge	Human-body model (HBM), per AEC Q100-002 ⁽¹⁾	±2000
		Charged-device model (CDM), per AEC Q100-011	±750

- (1) AEC Q100-002 indicates that HBM stressing shall be in accordance with the ANSI/ESDA/JEDEC JS-001 specification.

6.3 Recommended Operating Conditions

over operating free-air temperature range (unless otherwise noted)

	MIN	NOM	MAX	UNIT
Supply voltage	2.7		5.5	V
Operating free-air temperature, T _A	-55		125	°C

6.4 Thermal Information

THERMAL METRIC ⁽¹⁾		TMP100-Q1, TMP101-Q1	UNIT
		DBV (SOT-23)	
		6 PINS	
R _{θJA}	Junction-to-ambient thermal resistance	182.9	°C/W
R _{θJC(top)}	Junction-to-case (top) thermal resistance	115	°C/W
R _{θJB}	Junction-to-board thermal resistance	30.2	°C/W
Ψ _{JT}	Junction-to-top characterization parameter	17.1	°C/W
Ψ _{JB}	Junction-to-board characterization parameter	29.7	°C/W

- (1) For more information about traditional and new thermal metrics, see the [Semiconductor and IC Package Thermal Metrics](#) application report.

6.5 Electrical Characteristics

At $T_A = -55^\circ\text{C}$ to 125°C and $V_+ = 2.7\text{ V}$ to 5.5 V , unless otherwise noted.

PARAMETER	TEST CONDITIONS	MIN	TYP	MAX	UNIT
TEMPERATURE INPUT					
Range		-55		125	$^\circ\text{C}$
Accuracy (temperature error)	-25 $^\circ\text{C}$ to 85 $^\circ\text{C}$		± 0.5	± 2	$^\circ\text{C}$
	-55 $^\circ\text{C}$ to 125 $^\circ\text{C}$		± 1	± 2	$^\circ\text{C}$
Accuracy (temperature error) vs. supply			0.2	± 0.5	$^\circ\text{C}/\text{V}$
Resolution	Selectable		0.0625		$^\circ\text{C}$
DIGITAL INPUT/OUTPUT					
Input capacitance			3		pF
V_{IH} High-level input logic		0.7 (V+)		6	V
V_{IL} Low-level input logic		-0.5		0.3 (V+)	V
I_{IN} Input current	$0\text{ V} \leq V_{IN} \leq 6\text{ V}$			1	μA
V_{OL} Low-level output logic SDA	$I_{OL} = 3\text{ mA}$	0	0.15	0.4	V
V_{OL} Low-level output logic ALERT	$I_{OL} = 4\text{ mA}$	0	0.15	0.4	V
Resolution	Selectable	9		12	Bits
Conversion time	9 bits		40	75	ms
	10 bits		80	150	
	11 bits		160	300	
	12 bits		320	600	
Conversion rate	9 bits		25		s/s
	10 bits		12		
	11 bits		6		
	12 bits		3		
POWER SUPPLY					
Operating range		2.7		5.5	V
I_Q Quiescent current	Serial bus inactive		45	75	μA
	Serial bus active, SCL frequency = 400 kHz		70		
	Serial bus active, SCL frequency = 3.4 MHz		150		
I_{SD} Shutdown current	Serial bus inactive		0.1	13	μA
	Serial bus active, SCL frequency = 400 kHz		20		
	Serial bus active, SCL frequency = 3.4 MHz		100		
TEMPERATURE RANGE					
Specified range		-55		125	$^\circ\text{C}$
Storage range		-60		150	$^\circ\text{C}$

6.6 Timing Requirements

PARAMETER		FAST MODE		HIGH-SPEED MODE		UNIT
		MIN	MAX	MIN	MAX	
$f_{(SCL)}$	SCL operating frequency		0.4		2	MHz
$t_{(BUF)}$	Bus free time between STOP and START condition	1300		160		ns
$t_{(HDSTA)}$	Hold time after repeated START condition. After this period, the first clock is generated.	600		160		ns
$t_{(SUSTA)}$	Repeated START condition setup time	600		160		ns
$t_{(SUSTO)}$	STOP condition setup time	600		160		ns
$t_{(HDDAT)}$	Data hold time	20	900	20	170	ns
$t_{(SUDAT)}$	Data setup time	100		20		ns
$t_{(LOW)}$	SCL clock LOW period	1300		360		ns
$t_{(HIGH)}$	SCL clock HIGH period	600		60		ns
t_{RC}, t_{FC}	Clock rise and fall time		300		40	ns
t_{RD}, t_{FD}	Data rise and fall time		300		170	ns

6.7 Typical Characteristics

At $T_A = 25^\circ\text{C}$ and $V_+ = 5\text{ V}$, unless otherwise noted.

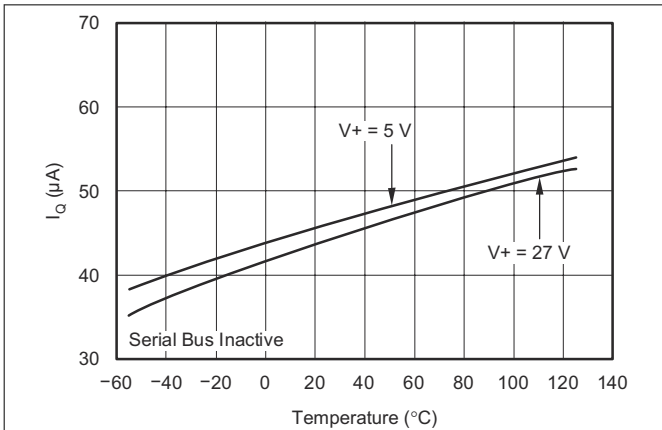

Figure 6-1. Quiescent Current vs. Temperature

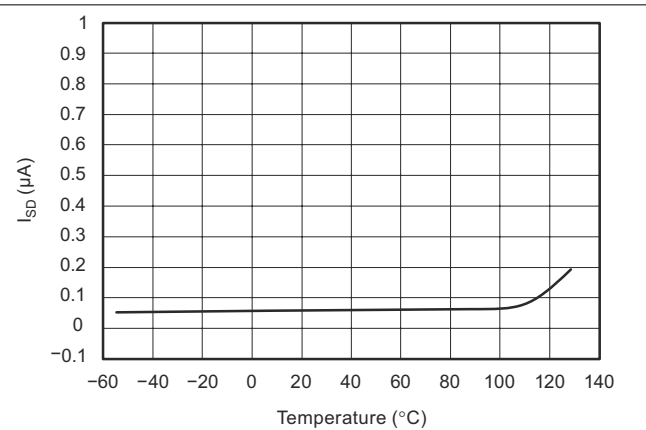

Figure 6-2. Shutdown Current vs. Temperature

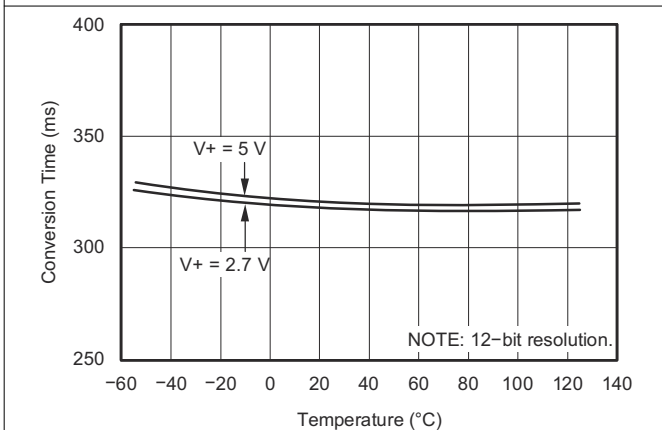

Figure 6-3. Conversion Time vs. Temperature

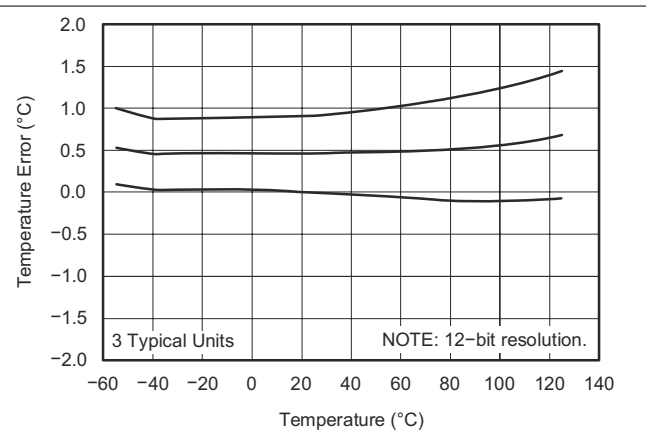

Figure 6-4. Temperature Accuracy vs. Temperature

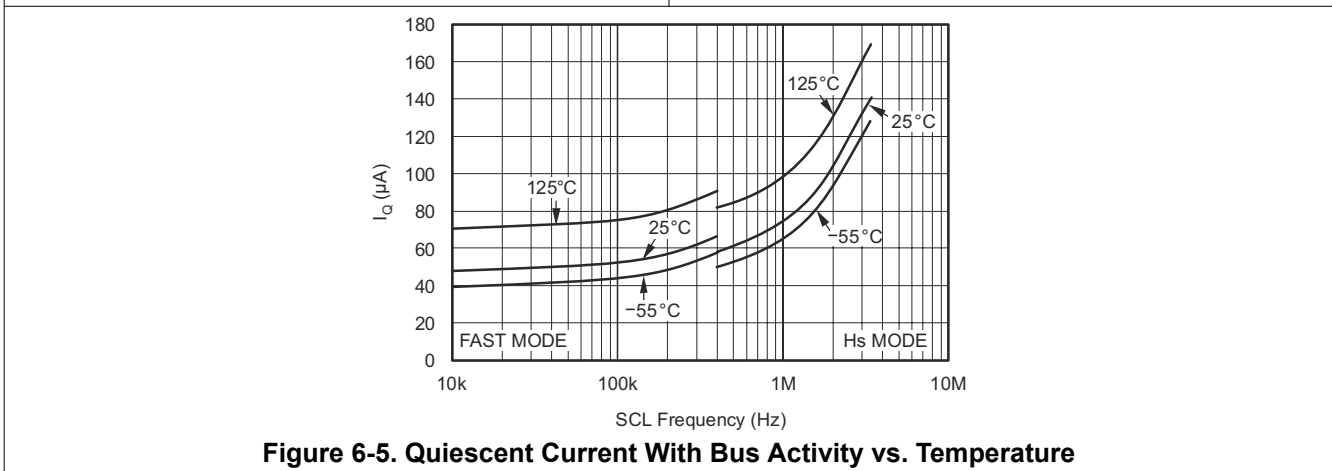

Figure 6-5. Quiescent Current With Bus Activity vs. Temperature

7 Detailed Description

7.1 Overview

The TMP100-Q1 and TMP101-Q1 devices are digital temperature sensors optimal for thermal management and thermal protection applications. The TMP100-Q1 and TMP101-Q1 devices are Two-Wire, SMBus, and I²C interface-compatible. These devices are specified over a operating temperature range of -55°C to 125°C. The *Functional Block Diagram* section shows the internal block diagrams of the TMP100-Q1 and TMP101-Q1 devices.

The temperature sensor in the TMP100-Q1 and TMP101-Q1 devices is the chip itself. Thermal paths run through the package leads as well as the plastic package. The package leads provide the primary thermal path because of the lower thermal resistance of the metal. The GND pin of the TMP100-Q1 or TMP101-Q1 is directly connected to the metal lead frame, and is the best choice for thermal input.

7.2 Functional Block Diagram

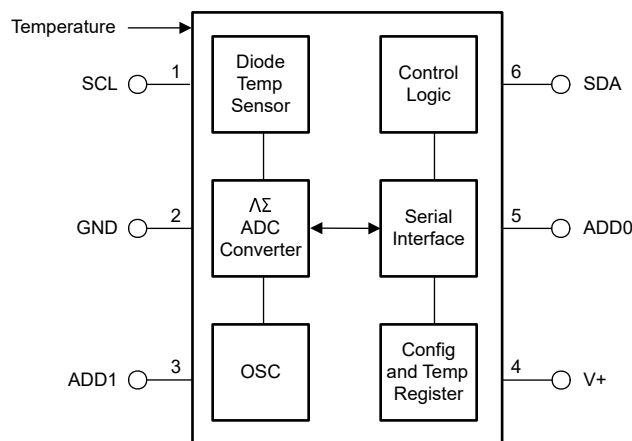

Figure 7-1. TMP100-Q1 Block Diagram

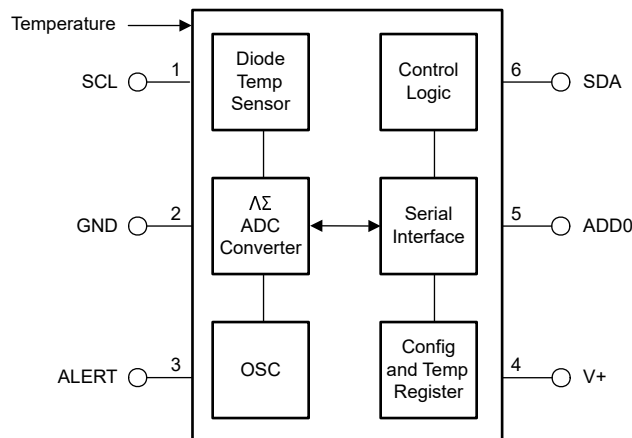

Figure 7-2. TMP101-Q1 Block Diagram

7.3 Feature Description

7.3.1 Digital Temperature Output

The digital output from each temperature measurement conversion is stored in the read-only Temperature Register. The Temperature Register of the TMP100-Q1 or TMP101-Q1 device is a 12-bit, read-only register that stores the output of the most recent conversion. Two bytes must be read to obtain data and are listed in [Table 7-6](#) and [Table 7-7](#). The first 12 bits are used to indicate temperature with all the remaining bits equal to zero. The data format for temperature is listed in [Table 7-1](#). Negative numbers are represented in binary twos complement format. Following power-up or reset, the temperature register reads 0°C until the first conversion is complete.

The user can obtain 9, 10, 11, or 12 bits of resolution by addressing the Configuration Register and setting the resolution bits accordingly. For 9-, 10-, or 11-bit resolution, the most significant bits (MSBs) in the Temperature Register are used with the unused least significant bits (LSBs) set to zero.

Table 7-1. Temperature Data Format

TEMPERATURE (°C)	DIGITAL OUTPUT	
	BINARY	HEX
128	0111 1111 1111	7FF
127.9375	0111 1111 1111	7FF
100	0110 0100 0000	640
80	0101 0000 0000	500
75	0100 1011 0000	4B0
50	0011 0010 0000	320
25	0001 1001 0000	190
0.25	0000 0000 0100	004
0	0000 0000 0000	000
-0.25	1111 1111 1100	FFC
-25	1110 0111 0000	E70
-55	1100 1001 0000	C90
-128	1000 0000 0000	800

7.3.2 Serial Interface

The TMP100-Q1 and TMP101-Q1 devices operate only as target devices on the SMBus, Two-Wire, and I²C interface-compatible bus. Connections to the bus are made through the open-drain I/O lines SDA and SCL. The TMP100-Q1 and TMP101-Q1 devices support the transmission protocol for fast (up to 400 kHz) and high-speed (up to 2 MHz) modes. All data bytes are transmitted MSB first.

7.3.3 Bus Overview

The device that initiates the transfer is called a *controller*, and the devices controlled by the controller are *targets*. The bus must be controlled by a controller device that generates the serial clock (SCL), controls the bus access, and generates the START and STOP conditions.

To address a specific device, a START condition is initiated, indicated by pulling the data line (SDA) from a HIGH to LOW logic level while SCL is HIGH. All targets on the bus shift in the target address byte, with the last bit indicating whether a read or write operation is intended. During the ninth clock pulse, the target being addressed responds to the controller by generating an Acknowledge and pulling SDA LOW.

Data transfer is then initiated and sent over eight clock pulses followed by an Acknowledge Bit. During data transfer, SDA must remain stable while SCL is HIGH because any change in SDA while SCL is HIGH is interpreted as a control signal.

When all data are transferred, the controller generates a STOP condition indicated by pulling SDA from LOW to HIGH, while SCL is HIGH.

7.3.4 Serial Bus Address

To program the TMP100-Q1 and TMP101-Q1 devices, the controller must first address target devices through a target address byte. The target address byte consists of seven address bits and a direction bit indicating the intent of executing a read or write operation.

The TMP100-Q1 device features two address pins to allow up to eight devices to be addressed on a single I²C interface. [Table 7-2](#) describes the pin logic levels used to properly connect up to eight devices. *Float* indicates the pin is left unconnected. The state of pins ADD0 and ADD1 is sampled on the first I²C bus communication and must be set before any activity on the interface.

Table 7-2. Address Pins and Target Addresses for the TMP100-Q1

ADD1	ADD0	TARGET ADDRESS
0	0	1001000
0	Float	1001001
0	1	1001010
1	0	1001100
1	Float	1001101
1	1	1001110
Float	0	1001011
Float	1	1001111

The TMP101-Q1 device features one address pin and an ALERT pin, allowing up to three devices to be connected per bus. Pin logic levels are described in [Table 7-3](#). The address pins of the TMP100-Q1 and TMP101-Q1 devices are read after reset or in response to an I²C address acquire request. Following reading, the state of the address pins is latched to minimize power dissipation associated with detection.

Table 7-3. Address Pins and Target Addresses for the TMP101-Q1

ADD0	TARGET ADDRESS
0	1001000
Float	1001001
1	1001010

7.3.5 Writing and Reading to the TMP100-Q1 and TMP101-Q1

Accessing a particular register on the TMP100-Q1 and TMP101-Q1 devices is accomplished by writing the appropriate value to the Pointer Register. The value for the Pointer Register is the first byte transferred after the I²C target address byte with the R/ \bar{W} bit LOW. Every write operation to the TMP100-Q1 and TMP101-Q1 devices requires a value for the Pointer Register (see [Figure 7-4](#)).

When reading from the TMP100-Q1 and TMP101-Q1 devices, the last value stored in the Pointer Register by a write operation is used to determine which register is read by a read operation. To change the register pointer for a read operation, a new value must be written to the Pointer Register. This action is accomplished by issuing an I²C target address byte with the R/ \bar{W} bit LOW, followed by the Pointer Register Byte. No additional data are required. The controller can then generate a START condition and send the I²C target address byte with the R/ \bar{W} bit HIGH to initiate the read command; see [Figure 7-5](#) for details of this sequence. If repeated reads from the same register are desired, the Pointer Register bytes do not have to be continually sent because the TMP100-Q1 and TMP101-Q1 devices remember the Pointer Register value until that value is changed by the next write operation.

7.3.6 Target Mode Operations

The TMP100-Q1 and TMP101-Q1 devices can operate as a target receiver or target transmitter.

7.3.6.1 Target Receiver Mode

The first byte transmitted by the controller is the target address, with the R/ \bar{W} bit LOW. The TMP100-Q1 or TMP101-Q1 devices then acknowledge reception of a valid address. The next byte transmitted by the controller is the Pointer Register. The TMP100-Q1 or TMP101-Q1 devices then acknowledge reception of the Pointer Register byte. The next byte or bytes are written to the register addressed by the Pointer Register. The TMP100-Q1 and TMP101-Q1 devices acknowledge reception of each data byte. The controller can terminate data transfer by generating a START or STOP condition.

7.3.6.2 Target Transmitter Mode

The first byte is transmitted by the controller and is the target address, with the R/ \bar{W} bit HIGH. The target acknowledges reception of a valid target address. The next byte is transmitted by the target and is the most significant byte of the register indicated by the Pointer Register. The controller acknowledges reception of the data byte. The next byte transmitted by the target is the least significant byte. The controller acknowledges reception of the data byte. The controller can terminate data transfer by generating a Not-Acknowledge on reception of any data byte, or generating a START or STOP condition.

7.3.7 SMBus Alert Function

The TMP101-Q1 device supports the SMBus Alert function. When the TMP101-Q1 device is operating in Interrupt Mode (TM = 1), the ALERT pin of the TMP101-Q1 device can be connected as an SMBus Alert signal. When a controller senses that an ALERT condition is present on the ALERT line, the controller sends an SMBus Alert command (00011001) on the bus. If the ALERT pin of the TMP101-Q1 device is active, the TMP101-Q1 device acknowledges the SMBus Alert command and responds by returning its target address on the SDA line. The eighth bit (LSB) of the target address byte indicates if the temperature exceeding T_{HIGH} or falling below T_{LOW} caused the ALERT condition. For POL = 0, this bit is LOW if the temperature is greater than or equal to T_{HIGH} . This bit is HIGH if the temperature is less than T_{LOW} . The polarity of this bit is inverted if POL = 1; see [Figure 7-6](#) for details of this sequence.

If multiple devices on the bus respond to the SMBus Alert command, arbitration during the target address portion of the SMBus alert command determine which device clears its ALERT status. If the TMP101-Q1 device wins the arbitration, its ALERT pin becomes inactive at the completion of the SMBus Alert command. If the TMP101-Q1 loses the arbitration, its ALERT pin remains active.

The TMP100-Q1 device also responds to the SMBus ALERT command if its TM bit is set to 1. Because the device does not have an ALERT pin, the device must periodically poll the device by issuing an SMBus Alert command. If the TMP100-Q1 device generates an ALERT, the device acknowledges the SMBus Alert command and returns its target address in the next byte.

7.3.8 General Call

The TMP100-Q1 and TMP101-Q1 devices respond to the I²C General Call address (0000000) if the eighth bit is 0. The device acknowledges the General Call address and responds to commands in the second byte. If the second byte is 00000100, the TMP100-Q1 and TMP101-Q1 devices latch the status of their address pins, but do not reset. If the second byte is 00000110, the TMP100-Q1 and TMP101-Q1 devices latch the status of their address pins and reset their internal registers.

7.3.9 High-Speed Mode

In order for the I²C bus to operate at frequencies above 400 kHz, the controller device must issue an Hs-mode controller code (00001XXX) as the first byte after a START condition to switch the bus to high-speed operation. The TMP100-Q1 and TMP101-Q1 devices do not acknowledge this byte as required by the I²C specification, but do switch their input filters on SDA and SCL and their output filters on SDA to operate in Hs-mode, allowing transfers at up to 2 MHz. After the Hs-mode controller code is issued, the controller transmits an I²C target address to initiate a data transfer operation. The bus continues to operate in Hs-mode until a STOP condition

occurs on the bus. Upon receiving the STOP condition, the TMP100-Q1 and TMP101-Q1 devices switch the input and output filter back to fast-mode operation.

7.3.10 POR (Power-On Reset)

The TMP100-Q1 and TMP101-Q1 devices both have on-chip, power-on reset circuits that reset the device to default settings when the device is powered on. This circuit activates when the power supply is less than 0.3 V for more than 100 ms. If the TMP100-Q1 and TMP101-Q1 devices are powered down by removing supply voltage from the device, but the supply voltage is not assured to be less than 0.3 V, TI recommends issuing a General Call reset command on the I²C interface bus to ensure that the TMP100-Q1 and TMP101-Q1 devices are completely reset.

7.3.11 Timing Diagrams

The TMP100-Q1 and TMP101-Q1 devices are Two-Wire, SMBUs, and I²C interface-compatible. Figure 7-3 to Figure 7-6 describe the various operations on the TMP100-Q1 and TMP101-Q1. The following list provides bus definitions. Parameters for Figure 7-3 are defined in the *Timing Requirements* table.

Bus Idle: Both SDA and SCL lines remain HIGH.

Start Data Transfer: A change in the state of the SDA line, from HIGH to LOW, while the SCL line is HIGH, defines a START condition. Each data transfer is initiated with a START condition.

Stop Data Transfer: A change in the state of the SDA line from LOW to HIGH while the SCL line is HIGH defines a STOP condition. Each data transfer is terminated with a repeated START or STOP condition.

Data Transfer: The number of data bytes transferred between a START and a STOP condition is not limited and is determined by the controller device. The receiver acknowledges the transfer of data.

Acknowledge: Each receiving device, when addressed, is obliged to generate an Acknowledge bit. A device that acknowledges must pull down the SDA line during the Acknowledge clock pulse in such a way that the SDA line is stable LOW during the HIGH period of the Acknowledge clock pulse. Setup and hold times must be taken into account. On a controller receive, the termination of the data transfer can be signaled by the controller generating a Not-Acknowledge on the last byte that is transmitted by the target.

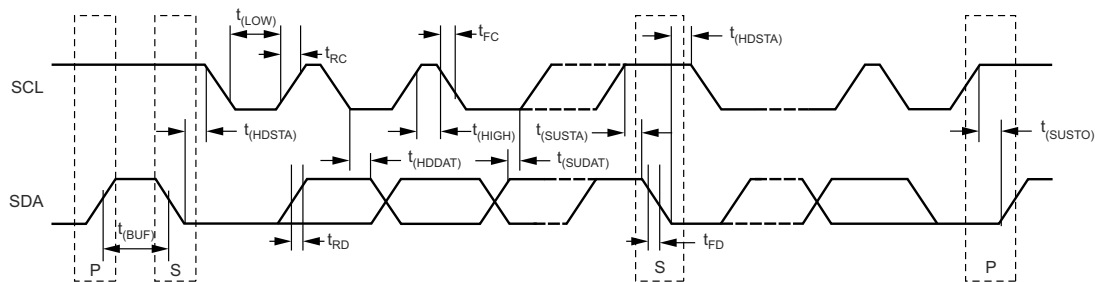

Figure 7-3. I²C Timing Diagram

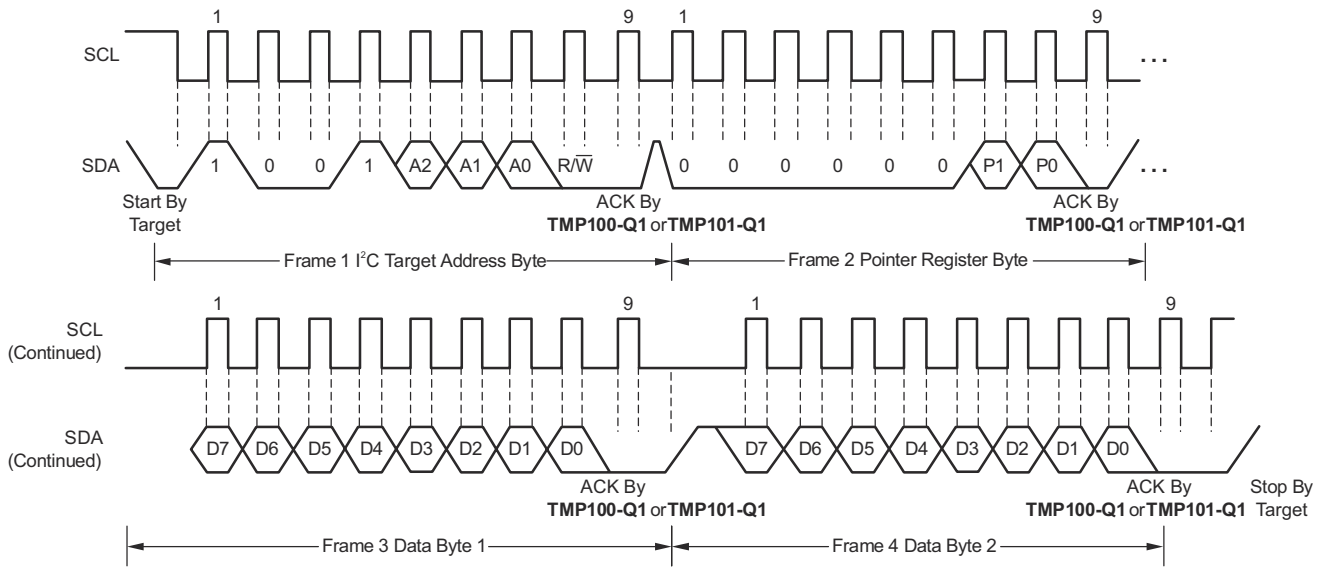

Figure 7-4. I²C Timing Diagram for Write Word Format

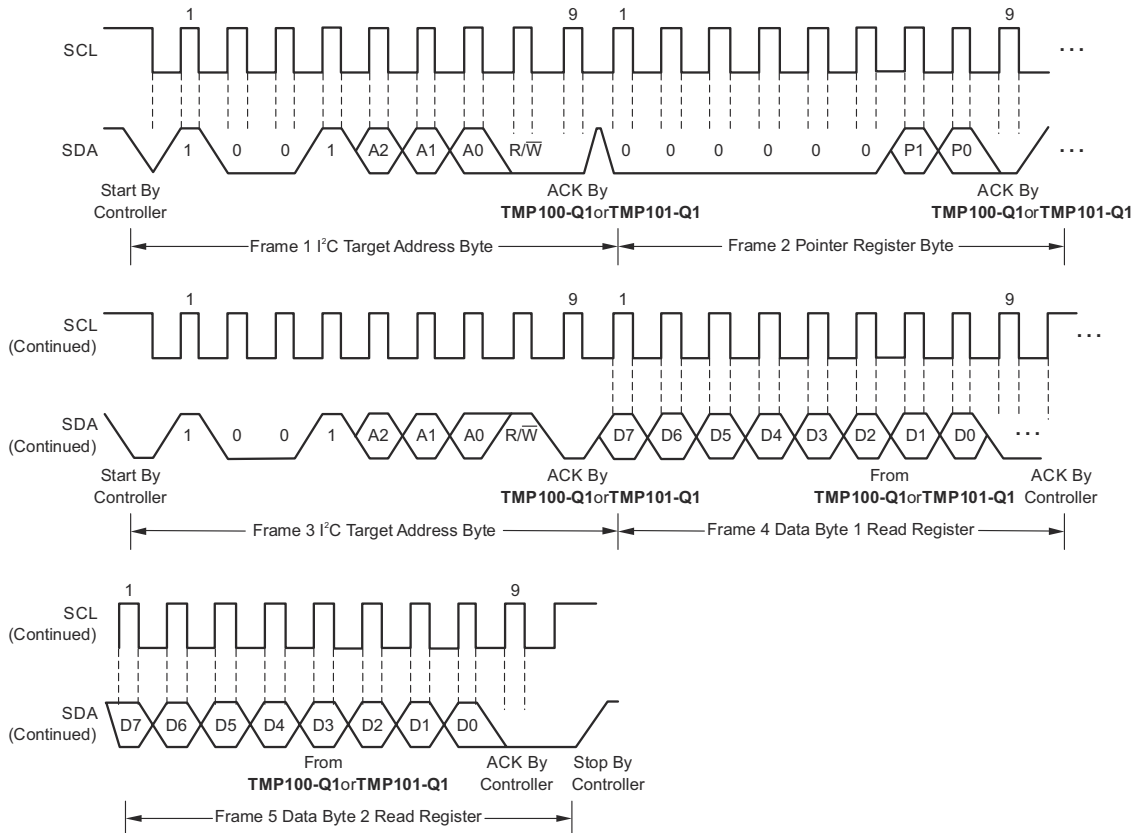

Figure 7-5. I²C Timing Diagram for Read Word Format

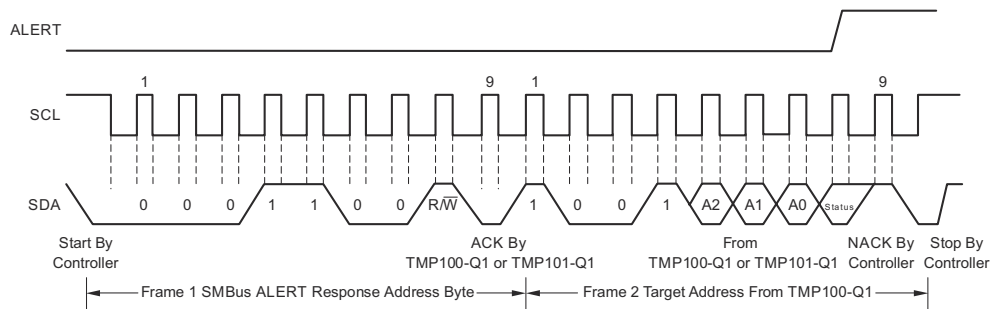

Figure 7-6. Timing Diagram for SMBus ALERT

7.4 Device Functional Modes

7.4.1 Shutdown Mode (SD)

The Shutdown Mode of the TMP100-Q1 and TMP101-Q1 devices lets the user save maximum power by shutting down all device circuitry other than the serial interface, which reduces current consumption to less than 1 μ A. For the TMP100-Q1 and TMP101-Q1 devices, Shutdown Mode is enabled when the SD bit is 1. The device shuts down when the current conversion is completed. For SD equal to 0, the device maintains continuous conversion.

7.4.2 OS/ALERT (OS)

The TMP100-Q1 and TMP101-Q1 devices feature a One-Shot Temperature Measurement Mode. When the device is in Shutdown Mode, writing 1 to the OS/ALERT bit starts a single temperature conversion. The device returns to the shutdown state at the completion of the single conversion. This feature is useful to reduce power consumption in the TMP100-Q1 and TMP101-Q1 devices when continuous monitoring of temperature is not required.

Reading the OS/ALERT bit provides information about the Comparator Mode status. The state of the POL bit inverts the polarity of data returned from the OS/ALERT bit. For POL = 0, the OS/ALERT reads as 1 until the temperature equals or exceeds T_{HIGH} for the programmed number of consecutive faults, causing the OS/ALERT bit to read as 0. The OS/ALERT bit continues to read as 0 until the temperature falls below T_{LOW} for the programmed number of consecutive faults when the OS/ALERT bit again reads as 1. The status of the TM bit does not affect the status of the OS/ALERT bit.

7.4.3 Thermostat Mode (TM)

The Thermostat Mode bit of the TMP101-Q1 device indicates to the device whether to operate in Comparator Mode (TM = 0) or Interrupt Mode (TM = 1). For more information on comparator and interrupt modes, see the [High- and Low-Limit Registers](#) section.

7.4.4 Comparator Mode (TM = 0)

In Comparator Mode (TM = 0), the ALERT pin is activated when the temperature equals or exceeds the value in the T_{HIGH} register and remains active until the temperature falls below the value in the T_{LOW} register. For more information on the Comparator Mode, see the [High- and Low-Limit Registers](#) section.

7.4.5 Interrupt Mode (TM = 1)

In Interrupt Mode (TM = 1), the ALERT pin is activated when the temperature exceeds T_{HIGH} or goes below the T_{LOW} registers. The ALERT pin is cleared when the host controller reads the temperature register. For more information on the interrupt mode, see the [High- and Low-Limit Registers](#) section.

7.5 Programming

7.5.1 Pointer Register

[Figure 7-7](#) shows the internal register structure of the TMP100-Q1 and TMP101-Q1 devices. The 8-bit Pointer Register of the TMP100-Q1 and TMP101-Q1 devices is used to address a given data register. The Pointer Register uses the two LSBs to identify which of the data registers respond to a read or write command. [Table 7-4](#)

identifies the bits of the Pointer Register byte. [Table 7-5](#) describes the pointer address of the registers available in the TMP100-Q1 and TMP101-Q1 devices. The power-up reset value of P1 and P0 is 00.

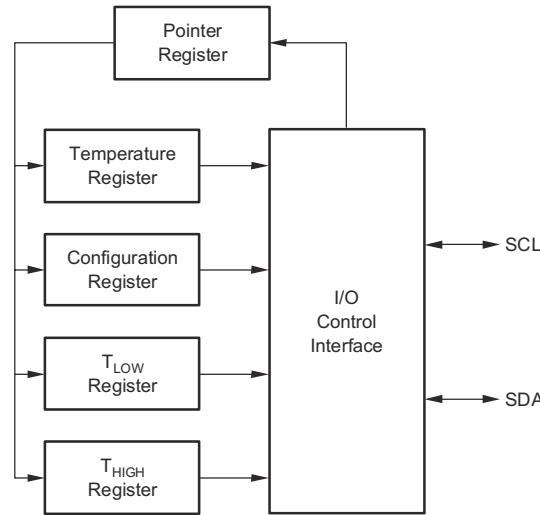

Figure 7-7. Internal Register Structure of the TMP100-Q1 and TMP101-Q1

7.5.1.1 Pointer Register Byte (pointer = N/A) [reset = 00h]

Table 7-4. Pointer Register Byte

P7	P6	P5	P4	P3	P2	P1	P0
0	0	0	0	0	0	Register Bits	

7.5.1.2 Pointer Addresses of the TMP100-Q1 and TMP101-Q1 Registers

Table 7-5. Pointer Addresses of the TMP100-Q1 and TMP101-Q1 Registers

P1	P0	TYPE	REGISTER
0	0	R only, default	Temperature Register
0	1	R/W	Configuration Register
1	0	R/W	T _{LOW} Register
1	1	R/W	T _{HIGH} Register

7.5.2 Temperature Register

The Temperature Register of the TMP100-Q1 or TMP101-Q1 devices is a 12-bit, read-only register that stores the output of the most recent conversion. Two bytes must be read to obtain data, and are described in [Table 7-6](#) and [Table 7-7](#). The first 12 bits are used to indicate temperature, with all remaining bits equal to zero. Data format for temperature is summarized in [Table 7-1](#). Following power-up or reset, the Temperature Register reads 0°C until the first conversion is complete.

Table 7-6. Byte 1 of the Temperature Register

D7	D6	D5	D4	D3	D2	D1	D0
T11	T10	T9	T8	T7	T6	T5	T4

Table 7-7. Byte 2 of the Temperature Register

D7	D6	D5	D4	D3	D2	D1	D0
T3	T2	T1	T0	0	0	0	0

7.5.3 Configuration Register

The Configuration Register is an 8-bit read and write register used to store bits that control the operational modes of the temperature sensor. Read and write operations are performed MSB-first. The format of the Configuration Register for the TMP100-Q1 and TMP101-Q1 devices is shown in [Table 7-8](#), followed by a breakdown of the register bits. The power-up or reset value of the Configuration Register is all bits equal to 0. The OS/ALERT bit reads as 1 after power-up or reset value.

Table 7-8. Configuration Register Format

BYTE	D7	D6	D5	D4	D3	D2	D1	D0
1	OS/ALERT	R1	R0	F1	F0	POL	TM	SD

7.5.3.1 Shutdown Mode (SD)

The Shutdown Mode of the TMP100-Q1 and TMP101-Q1 devices allows the user to save maximum power by shutting down all device circuitry other than the serial interface, which reduces current consumption to less than 1 μ A. For the TMP100-Q1 and TMP101-Q1 devices, Shutdown Mode is enabled when the SD bit is 1. The device shuts down when the current conversion is completed. For SD equal to 0, the device maintains continuous conversion.

7.5.3.2 Thermostat Mode (TM)

The Thermostat Mode bit of the TMP101-Q1 device indicates to the device whether to operate in Comparator Mode (TM = 0) or Interrupt Mode (TM = 1). For more information on comparator and interrupt modes, see [High- and Low-Limit Registers](#).

7.5.3.3 Polarity (POL)

The Polarity bit of the TMP101-Q1 device lets the user adjust the polarity of the ALERT pin output. If the POL bit is set to 0 (default), the ALERT pin becomes active low. When the POL bit is set to 1, the ALERT pin becomes active high and the state of the ALERT pin is inverted. The operation of the ALERT pin in various modes is illustrated in [Figure 7-8](#).

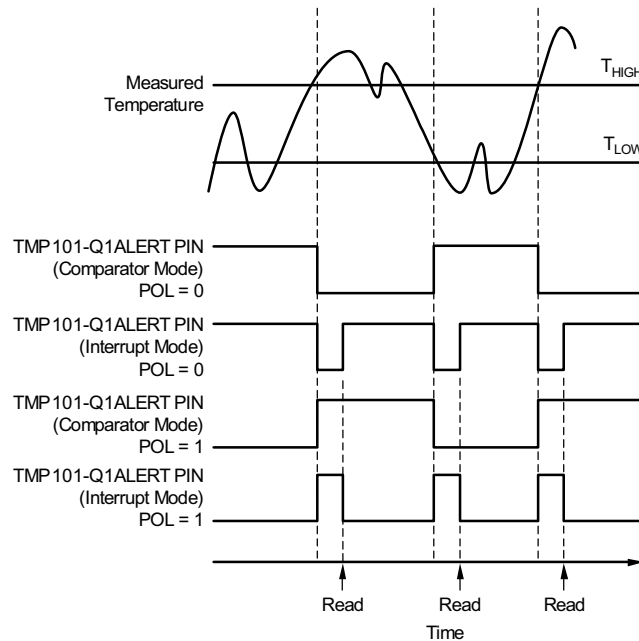

Figure 7-8. Output Transfer Function Diagrams

7.5.3.4 Fault Queue (F1, F0)

A fault condition occurs when the measured temperature exceeds the user-defined limits set in the T_{HIGH} and T_{LOW} Registers. Additionally, the number of fault conditions required to generate an alert can be programmed using the Fault Queue. The Fault Queue is provided to prevent a false alert resulting from environmental noise. The Fault Queue requires consecutive fault measurements in order to trigger the alert function. If the temperature falls below T_{LOW} before reaching the number of programmed consecutive faults limit, the count is reset to 0. Table 7-9 defines the number of measured faults that can be programmed to trigger an alert condition in the device.

Table 7-9. Fault Settings of the TMP100-Q1 and TMP101-Q1

F1	F0	CONSECUTIVE FAULTS
0	0	1
0	1	2
1	0	4
1	1	6

7.5.3.5 Converter Resolution (R1, R0)

The Converter Resolution bits control the resolution of the internal analog-to-digital converter (ADC), thus allowing the user to maximize efficiency by programming for higher resolution or faster conversion time. Table 7-10 identifies the Resolution bits and the relationship between resolution and conversion time.

Table 7-10. Resolution of the TMP100-Q1 and TMP101-Q1

R1	R0	RESOLUTION	CONVERSION TIME (Typical)
0	0	9 bits (0.5°C)	40 ms
0	1	10 bits (0.25°C)	80 ms
1	0	11 bits (0.125°C)	160 ms
1	1	12 bits (0.0625°C)	320 ms

7.5.3.6 OS/ALERT (OS)

The TMP100-Q1 and TMP101-Q1 devices feature a One-Shot Temperature Measurement Mode. When the device is in Shutdown Mode, writing 1 to the OS/ALERT bit starts a single temperature conversion. The device returns to the shutdown state at the completion of the single conversion. This feature is useful to reduce power consumption in the TMP100-Q1 and TMP101-Q1 when continuous temperature monitoring is not required.

Reading the OS/ALERT bit provides information about the Comparator Mode status. The state of the POL bit inverts the polarity of data returned from the OS/ALERT bit. For POL = 0, the OS/ALERT reads as 1 until the temperature equals or exceeds T_{HIGH} for the programmed number of consecutive faults, causing the OS/ALERT bit to read as 0. The OS/ALERT bit continues to read as 0 until the temperature falls below T_{LOW} for the programmed number of consecutive faults when the OS/ALERT bit again reads as 1. The status of the TM bit does not affect the status of the OS/ALERT bit.

7.5.4 High- and Low-Limit Registers

In Comparator Mode (TM = 0), the ALERT pin of the TMP101-Q1 becomes active when the temperature equals or exceeds the value in T_{HIGH} and generates a consecutive number of faults according to fault bits F1 and F0. The ALERT pin remains active until the temperature falls below the indicated T_{LOW} value for the same number of faults.

In Interrupt Mode (TM = 1) the ALERT pin becomes active when the temperature equals or exceeds T_{HIGH} for a consecutive number of fault conditions. The ALERT pin remains active until a read operation of any register occurs or the device successfully responds to the SMBus Alert Response Address. The ALERT pin is also cleared if the device is placed in Shutdown Mode. When the ALERT pin is cleared, it only becomes active again by the temperature falling below T_{LOW} . When the temperature falls below T_{LOW} , the ALERT pin becomes active and remains active until cleared by a read operation of any register or a successful response to the SMBus Alert Response Address. When the ALERT pin is cleared, the above cycle repeats with the ALERT pin becoming active when the temperature equals or exceeds T_{HIGH} . The ALERT pin can also be cleared by resetting the device with the General Call Reset command. This action also clears the state of the internal registers in the device, returning the device to Comparator Mode (TM = 0).

Both operational modes are represented in [Figure 7-8](#), [Table 7-11](#), [Table 7-12](#), [Table 7-13](#), and [Table 7-14](#) describe the format for the T_{HIGH} and T_{LOW} registers. Power-up reset values for T_{HIGH} and T_{LOW} are: $T_{HIGH} = 80^{\circ}C$ and $T_{LOW} = 75^{\circ}C$. The format of the data for T_{HIGH} and T_{LOW} is the same as for the Temperature Register.

Table 7-11. Byte 1 of the T_{HIGH} Register

D7	D6	D5	D4	D3	D2	D1	D0
H11	H10	H9	H8	H7	H6	H5	H4

Table 7-12. Byte 2 of the T_{HIGH} Register

D7	D6	D5	D4	D3	D2	D1	D0
H3	H2	H1	H0	0	0	0	0

Table 7-13. Byte 1 of the T_{LOW} Register

D7	D6	D5	D4	D3	D2	D1	D0
L11	L10	L9	L8	L7	L6	L5	L4

Table 7-14. Byte 2 of the T_{LOW} Register

D7	D6	D5	D4	D3	D2	D1	D0
L3	L2	L1	L0	0	0	0	0

All 12 bits for the Temperature, T_{HIGH} , and T_{LOW} registers are used in the comparisons for the ALERT function for all converter resolutions. The three LSBs in T_{HIGH} and T_{LOW} can affect the ALERT output even if the converter is configured for 9-bit resolution.

8 Application and Implementation

Note

Information in the following applications sections is not part of the TI component specification, and TI does not warrant its accuracy or completeness. TI's customers are responsible for determining suitability of components for their purposes, as well as validating and testing their design implementation to confirm system functionality.

8.1 Application Information

The TMP100-Q1 and TMP101-Q1 devices are used to measure the printed circuit board (PCB) temperature of the board location where the devices are mounted. The TMP100-Q1 features two address pins to allow up to eight devices to be addressed on a single I²C interface. The TMP101-Q1 device features one address pin and an ALERT pin, allowing up to three devices to be connected per bus. The TMP100-Q1 and TMP101-Q1 devices require no external components for operation except for pullup resistors on SCL, SDA, and ALERT (TMP101-Q1 device), although a 0.1- μ F bypass capacitor is recommended.

The sensing device of the TMP100-Q1 and TMP101-Q1 devices is the chip itself. Thermal paths run through the package leads as well as the plastic package. The die flag of the lead frame is connected to GND. The lower thermal resistance of metal causes the leads to provide the primary thermal path. The GND pin of the TMP100-Q1 or TMP101-Q1 device is directly connected to the metal lead frame, and is the best choice for thermal input.

8.2 Typical Application

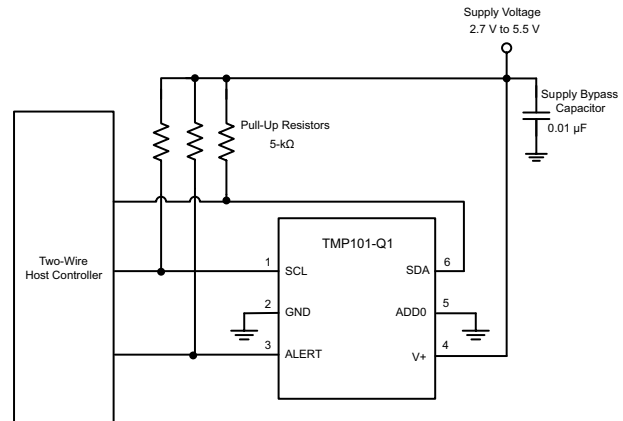
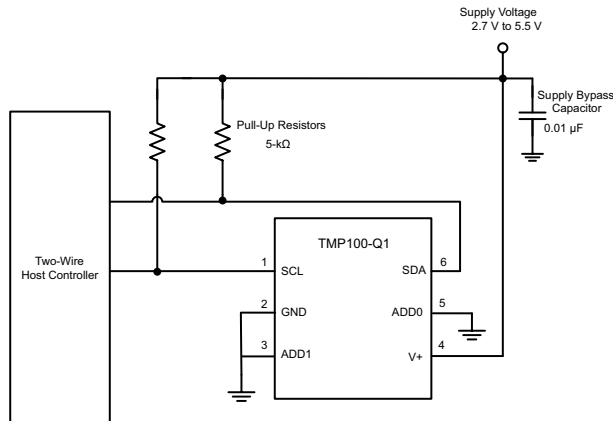

Figure 8-1. Typical Connections of the TMP100-Q1 **Figure 8-2. Typical Connections of the TMP101-Q1**

8.2.1 Design Requirements

The TMP100-Q1 and TMP101-Q1 devices require pullup resistors on the SCL, SDA, and ALERT (TMP101-Q1 device) pins. The recommended value for the pullup resistor is 5-k Ω . In some applications, the pullup resistor can be lower or higher than 5-k Ω but must not exceed 3 mA of current on the SCL and SDA pins, and must not exceed 4 mA on the ALERT (TMP101-Q1) pin. A 0.1- μ F bypass capacitor is recommended, as shown in [Figure 8-1](#) and [Figure 8-2](#). The SCL, SDA, and ALERT lines can be pulled up to a supply that is equal to or higher than V_S through the pullup resistors. For the TMP100-Q1, to configure one of eight different addresses on the bus, connect ADD0 and ADD1 to either the GND pin, V+ pin, or float. Float indicates the pin is left unconnected. For the TMP101-Q1 device, to configure one of three different addresses on the bus, connect ADD0 to either the GND pin, V+ pin, or float.

8.2.2 Detailed Design Procedure

Place the TMP100-Q1 and TMP101-Q1 devices in close proximity to the heat source that must be monitored, with a proper layout for good thermal coupling. This placement ensures that temperature changes are captured

within the shortest possible time interval. To maintain accuracy in applications that require air or surface temperature measurement, care must be taken to isolate the package and leads from ambient air temperature. A thermally-conductive adhesive is helpful in achieving accurate surface temperature measurement.

8.2.3 Application Curve

Figure 8-3 shows the step response of the TMP100-Q1 and TMP101-Q1 devices to a submersion in an oil bath of 100°C from room temperature (27°C). The time constant, or the time for the output to reach 63% of the input step, is 0.9 s. The time-constant result depends on the PCB that the TMP100-Q1 and TMP101-Q1 devices are mounted. For this test, the TMP100-Q1 and TMP101-Q1 devices are soldered to a two-layer PCB that measures 0.375 inch × 0.437 inch.

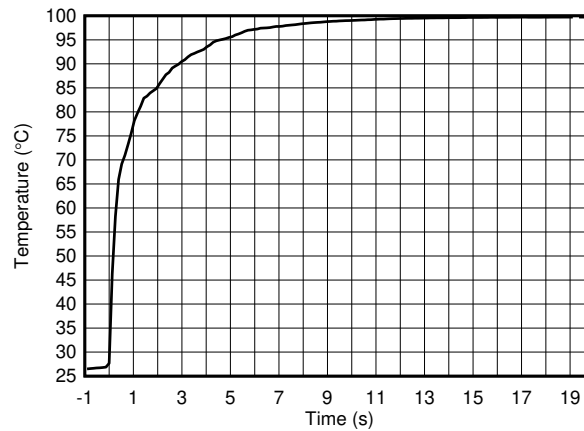

Figure 8-3. Temperature Step Response

9 Power Supply Recommendations

The TMP100-Q1 and TMP101-Q1 devices operate with power supply in the range of 2.7 V to 5.5 V. A power-supply bypass capacitor is required for stability; place this capacitor as close as possible to the supply and ground pins of the device. A typical value for this supply bypass capacitor is 0.01 μF. Applications with noisy or high-impedance power supplies can require additional decoupling capacitors to reject power-supply noise.

10 Layout

10.1 Layout Guidelines

Place the power-supply bypass capacitor as close as possible to the supply and ground pins. The recommended value of this bypass capacitor is 0.01 μF . Additional decoupling capacitance can be added to compensate for noisy or high-impedance power supplies. Pull up the open-drain output pins SDA , SCL, and ALERT (TMP101-Q1) through 5-k Ω pullup resistors.

10.2 Layout Examples

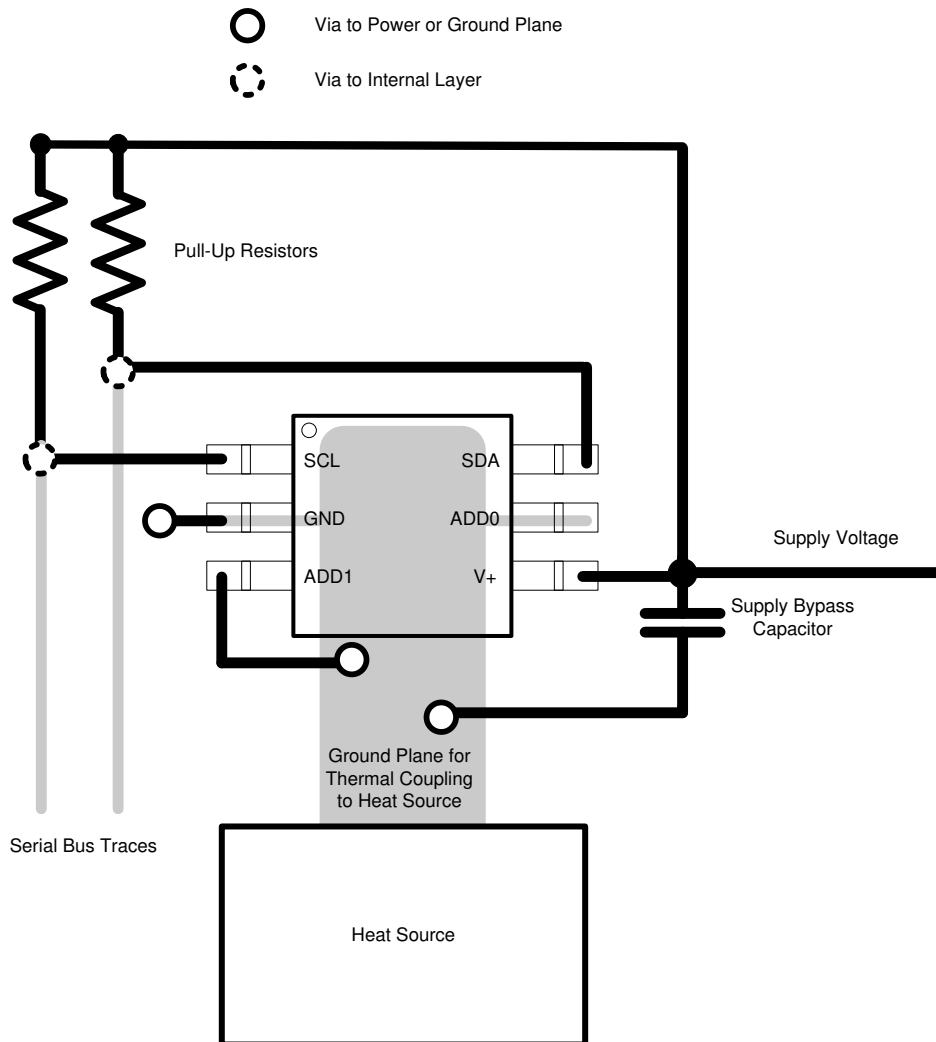

Figure 10-1. TMP100-Q1 Layout Example

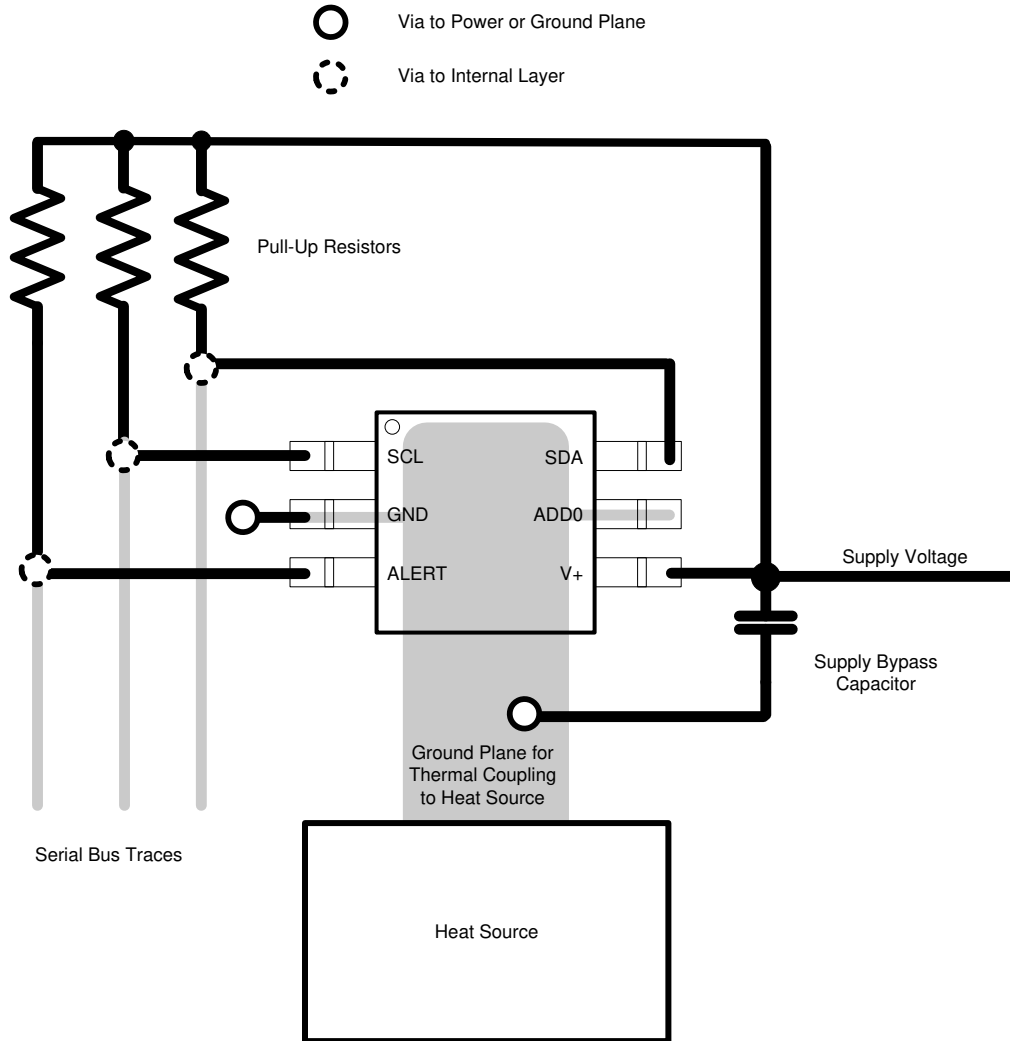

Figure 10-2. TMP101-Q1 Layout Example

11 Device and Documentation Support

11.1 Receiving Notification of Documentation Updates

To receive notification of documentation updates, navigate to the device product folder on ti.com. Click on *Subscribe to updates* to register and receive a weekly digest of any product information that has changed. For change details, review the revision history included in any revised document.

11.2 Support Resources

[TI E2E™ support forums](#) are an engineer's go-to source for fast, verified answers and design help — straight from the experts. Search existing answers or ask your own question to get the quick design help you need.

Linked content is provided "AS IS" by the respective contributors. They do not constitute TI specifications and do not necessarily reflect TI's views; see TI's [Terms of Use](#).

11.3 Trademarks

SMBus™ is a trademark of NXP Semiconductors.

TI E2E™ is a trademark of Texas Instruments.

All trademarks are the property of their respective owners.

11.4 Electrostatic Discharge Caution



This integrated circuit can be damaged by ESD. Texas Instruments recommends that all integrated circuits be handled with appropriate precautions. Failure to observe proper handling and installation procedures can cause damage.

ESD damage can range from subtle performance degradation to complete device failure. Precision integrated circuits may be more susceptible to damage because very small parametric changes could cause the device not to meet its published specifications.

11.5 Glossary

[TI Glossary](#) This glossary lists and explains terms, acronyms, and definitions.

12 Mechanical, Packaging, and Orderable Information

The following pages include mechanical, packaging, and orderable information. This information is the most current data available for the designated devices. This data is subject to change without notice and revision of this document. For browser-based versions of this data sheet, refer to the left-hand navigation.

PACKAGING INFORMATION

Orderable Device	Status (1)	Package Type	Package Drawing	Pins	Package Qty	Eco Plan (2)	Lead finish/ Ball material (6)	MSL Peak Temp (3)	Op Temp (°C)	Device Marking (4/5)	Samples
TMP100AQDBVRQ1	ACTIVE	SOT-23	DBV	6	3000	RoHS & Green	SN	Level-2-260C-1 YEAR	-40 to 125	100Q	Samples
TMP101NAQDBVRQ1	ACTIVE	SOT-23	DBV	6	3000	RoHS & Green	NIPDAU	Level-1-260C-UNLIM	-40 to 125	DUGQ	Samples

(1) The marketing status values are defined as follows:

ACTIVE: Product device recommended for new designs.

LIFEBUY: TI has announced that the device will be discontinued, and a lifetime-buy period is in effect.

NRND: Not recommended for new designs. Device is in production to support existing customers, but TI does not recommend using this part in a new design.

PREVIEW: Device has been announced but is not in production. Samples may or may not be available.

OBSOLETE: TI has discontinued the production of the device.

(2) **RoHS:** TI defines "RoHS" to mean semiconductor products that are compliant with the current EU RoHS requirements for all 10 RoHS substances, including the requirement that RoHS substance do not exceed 0.1% by weight in homogeneous materials. Where designed to be soldered at high temperatures, "RoHS" products are suitable for use in specified lead-free processes. TI may reference these types of products as "Pb-Free".

RoHS Exempt: TI defines "RoHS Exempt" to mean products that contain lead but are compliant with EU RoHS pursuant to a specific EU RoHS exemption.

Green: TI defines "Green" to mean the content of Chlorine (Cl) and Bromine (Br) based flame retardants meet JS709B low halogen requirements of <=1000ppm threshold. Antimony trioxide based flame retardants must also meet the <=1000ppm threshold requirement.

(3) MSL, Peak Temp. - The Moisture Sensitivity Level rating according to the JEDEC industry standard classifications, and peak solder temperature.

(4) There may be additional marking, which relates to the logo, the lot trace code information, or the environmental category on the device.

(5) Multiple Device Markings will be inside parentheses. Only one Device Marking contained in parentheses and separated by a "~" will appear on a device. If a line is indented then it is a continuation of the previous line and the two combined represent the entire Device Marking for that device.

(6) Lead finish/Ball material - Orderable Devices may have multiple material finish options. Finish options are separated by a vertical ruled line. Lead finish/Ball material values may wrap to two lines if the finish value exceeds the maximum column width.

Important Information and Disclaimer:The information provided on this page represents TI's knowledge and belief as of the date that it is provided. TI bases its knowledge and belief on information provided by third parties, and makes no representation or warranty as to the accuracy of such information. Efforts are underway to better integrate information from third parties. TI has taken and continues to take reasonable steps to provide representative and accurate information but may not have conducted destructive testing or chemical analysis on incoming materials and chemicals. TI and TI suppliers consider certain information to be proprietary, and thus CAS numbers and other limited information may not be available for release.

In no event shall TI's liability arising out of such information exceed the total purchase price of the TI part(s) at issue in this document sold by TI to Customer on an annual basis.

OTHER QUALIFIED VERSIONS OF TMP100-Q1, TMP101-Q1 :

- Catalog : [TMP100](#), [TMP101](#)
- Enhanced Product : [TMP100-EP](#)

NOTE: Qualified Version Definitions:

- Catalog - TI's standard catalog product
- Enhanced Product - Supports Defense, Aerospace and Medical Applications

TAPE AND REEL INFORMATION

QUADRANT ASSIGNMENTS FOR PIN 1 ORIENTATION IN TAPE

*All dimensions are nominal

Device	Package Type	Package Drawing	Pins	SPQ	Reel Diameter (mm)	Reel Width W1 (mm)	A0 (mm)	B0 (mm)	K0 (mm)	P1 (mm)	W (mm)	Pin1 Quadrant
TMP100AQDBVRQ1	SOT-23	DBV	6	3000	178.0	9.0	3.23	3.17	1.37	4.0	8.0	Q3
TMP101NAQDBVRQ1	SOT-23	DBV	6	3000	178.0	9.0	3.3	3.2	1.4	4.0	8.0	Q3

TAPE AND REEL BOX DIMENSIONS

*All dimensions are nominal

Device	Package Type	Package Drawing	Pins	SPQ	Length (mm)	Width (mm)	Height (mm)
TMP100AQDBVRQ1	SOT-23	DBV	6	3000	445.0	220.0	345.0
TMP101NAQDBVRQ1	SOT-23	DBV	6	3000	445.0	220.0	345.0

DBV0006A



PACKAGE OUTLINE

SOT-23 - 1.45 mm max height

SMALL OUTLINE TRANSISTOR

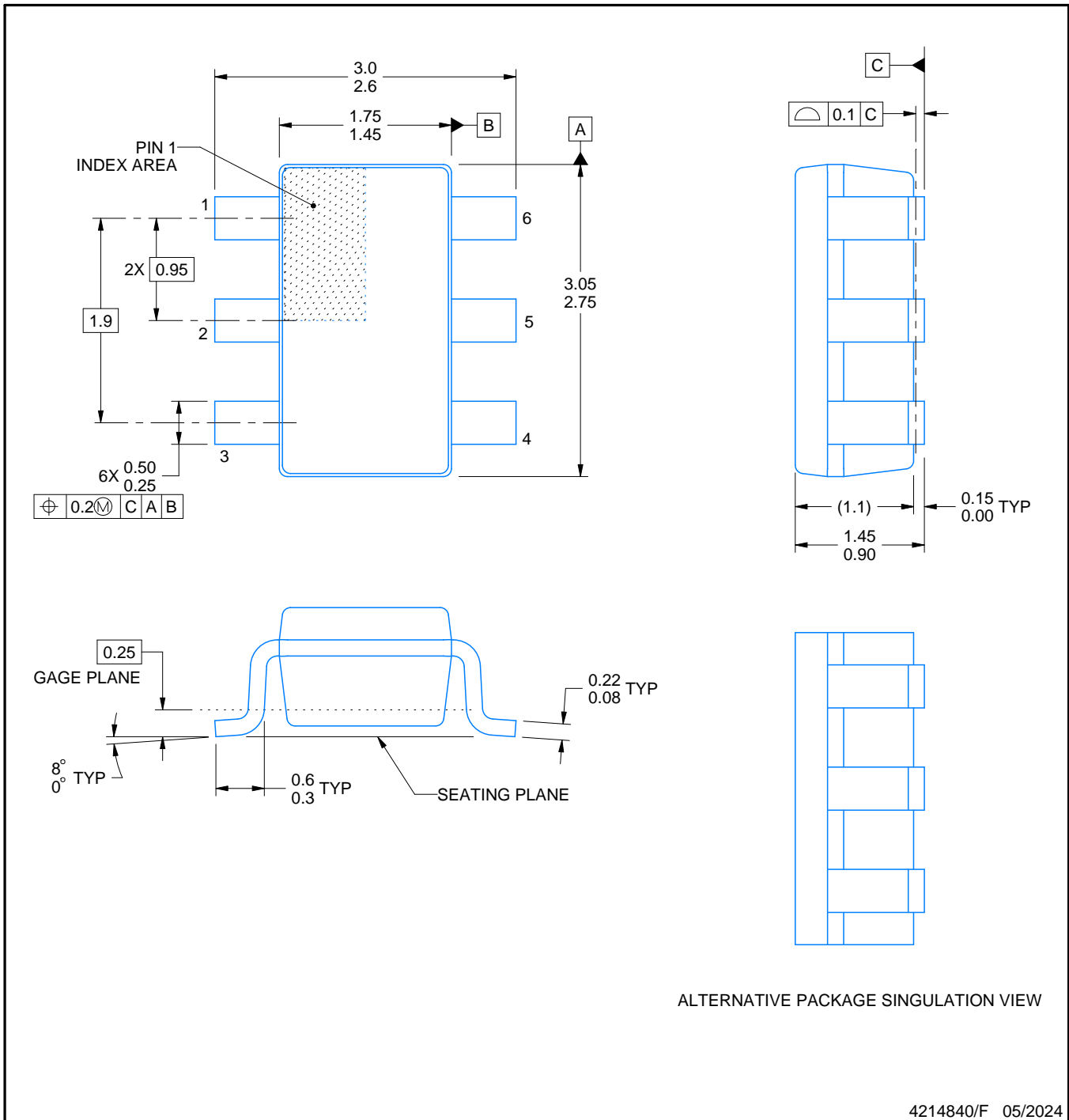

NOTES:

1. All linear dimensions are in millimeters. Any dimensions in parenthesis are for reference only. Dimensioning and tolerancing per ASME Y14.5M.
2. This drawing is subject to change without notice.
3. Body dimensions do not include mold flash or protrusion. Mold flash and protrusion shall not exceed 0.25 per side.
4. Leads 1,2,3 may be wider than leads 4,5,6 for package orientation.
5. Reference JEDEC MO-178.

EXAMPLE BOARD LAYOUT

DBV0006A

SOT-23 - 1.45 mm max height

SMALL OUTLINE TRANSISTOR

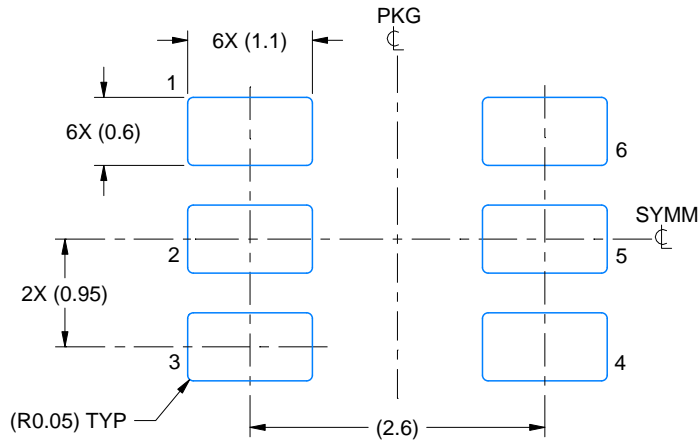

LAND PATTERN EXAMPLE
EXPOSED METAL SHOWN
SCALE:15X

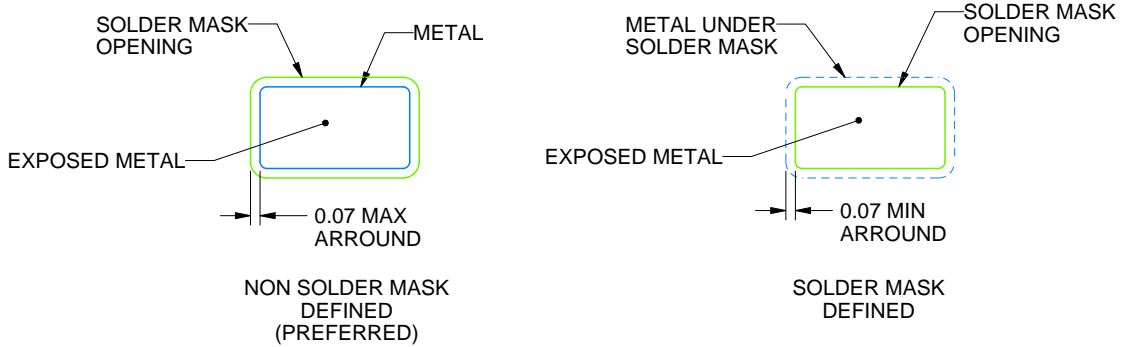

SOLDER MASK DETAILS

4214840/F 05/2024

NOTES: (continued)

- 6. Publication IPC-7351 may have alternate designs.
- 7. Solder mask tolerances between and around signal pads can vary based on board fabrication site.

EXAMPLE STENCIL DESIGN

DBV0006A

SOT-23 - 1.45 mm max height

SMALL OUTLINE TRANSISTOR

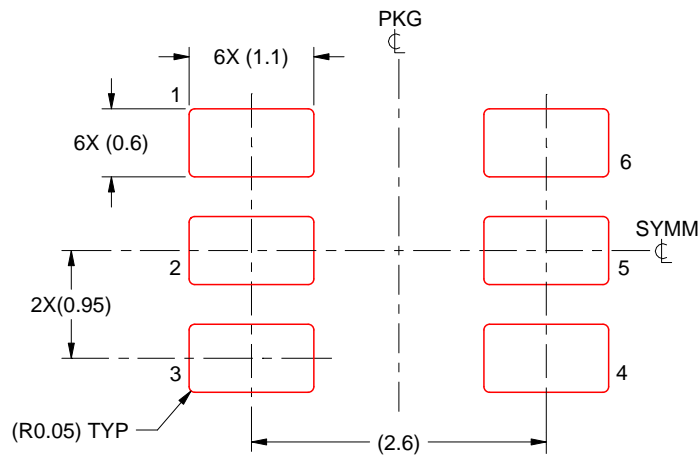

SOLDER PASTE EXAMPLE
BASED ON 0.125 mm THICK STENCIL
SCALE:15X

4214840/F 05/2024

NOTES: (continued)

8. Laser cutting apertures with trapezoidal walls and rounded corners may offer better paste release. IPC-7525 may have alternate design recommendations.
9. Board assembly site may have different recommendations for stencil design.

IMPORTANT NOTICE AND DISCLAIMER

TI PROVIDES TECHNICAL AND RELIABILITY DATA (INCLUDING DATA SHEETS), DESIGN RESOURCES (INCLUDING REFERENCE DESIGNS), APPLICATION OR OTHER DESIGN ADVICE, WEB TOOLS, SAFETY INFORMATION, AND OTHER RESOURCES "AS IS" AND WITH ALL FAULTS, AND DISCLAIMS ALL WARRANTIES, EXPRESS AND IMPLIED, INCLUDING WITHOUT LIMITATION ANY IMPLIED WARRANTIES OF MERCHANTABILITY, FITNESS FOR A PARTICULAR PURPOSE OR NON-INFRINGEMENT OF THIRD PARTY INTELLECTUAL PROPERTY RIGHTS.

These resources are intended for skilled developers designing with TI products. You are solely responsible for (1) selecting the appropriate TI products for your application, (2) designing, validating and testing your application, and (3) ensuring your application meets applicable standards, and any other safety, security, regulatory or other requirements.

These resources are subject to change without notice. TI grants you permission to use these resources only for development of an application that uses the TI products described in the resource. Other reproduction and display of these resources is prohibited. No license is granted to any other TI intellectual property right or to any third party intellectual property right. TI disclaims responsibility for, and you will fully indemnify TI and its representatives against, any claims, damages, costs, losses, and liabilities arising out of your use of these resources.

TI's products are provided subject to [TI's Terms of Sale](#) or other applicable terms available either on [ti.com](https://www.ti.com) or provided in conjunction with such TI products. TI's provision of these resources does not expand or otherwise alter TI's applicable warranties or warranty disclaimers for TI products.

TI objects to and rejects any additional or different terms you may have proposed.

Mailing Address: Texas Instruments, Post Office Box 655303, Dallas, Texas 75265
Copyright © 2024, Texas Instruments Incorporated

Looking for pricing, stock, or lifecycle information?

Click below to explore more details on WIN SOURCE:

- ⊖ [View TS317CW RPG on WIN SOURCE](#)
- ⊖ [Taiwan Semiconductor Information](#)

Optimize Your Supply Chain with WIN SOURCE Solutions

- ✓ Global Sourcing Solution
- ✓ Obsolete Management
- ✓ Cost Control Management
- ✓ Shortage Management
- ✓ Alternative Solution
- ✓ Excess Inventory Management