



**THE DATASHEET OF  
SC4911MSTRT**



### POWER MANAGEMENT

#### Description

The SC4911 is a highly integrated bias/primary side PWM controller designed for off-line or isolated dc-dc converters in telecommunication and data communication applications. The high degree of integration minimizes the amount of discrete parts needed and leads to substantial cost and space saving converter designs.

The circuitry of the SC4911 includes line voltage UVLO featuring startup current less than 50 $\mu$ A and programmable switching frequency. The device supply is derived from an auxiliary winding on the transformer. The auxiliary winding could also provide output feedback information if an optocoupler is not used.

#### Features

- ◆ Programmable switching frequency up to 500kHz
- ◆ Line UVLO Protection
- ◆ Undervoltage Lockout
- ◆ Low startup current (45 $\mu$ A)
- ◆ Cycle by cycle current limit
- ◆ 8 pin MSOP. Available in Lead-free, fully WEEE and RoHS compliant

#### Applications

- ◆ Telecom isolated converters
- ◆ Offline isolated power supplies
- ◆ Instrumentation power supplies
- ◆ Battery chargers

### Typical Application Circuit

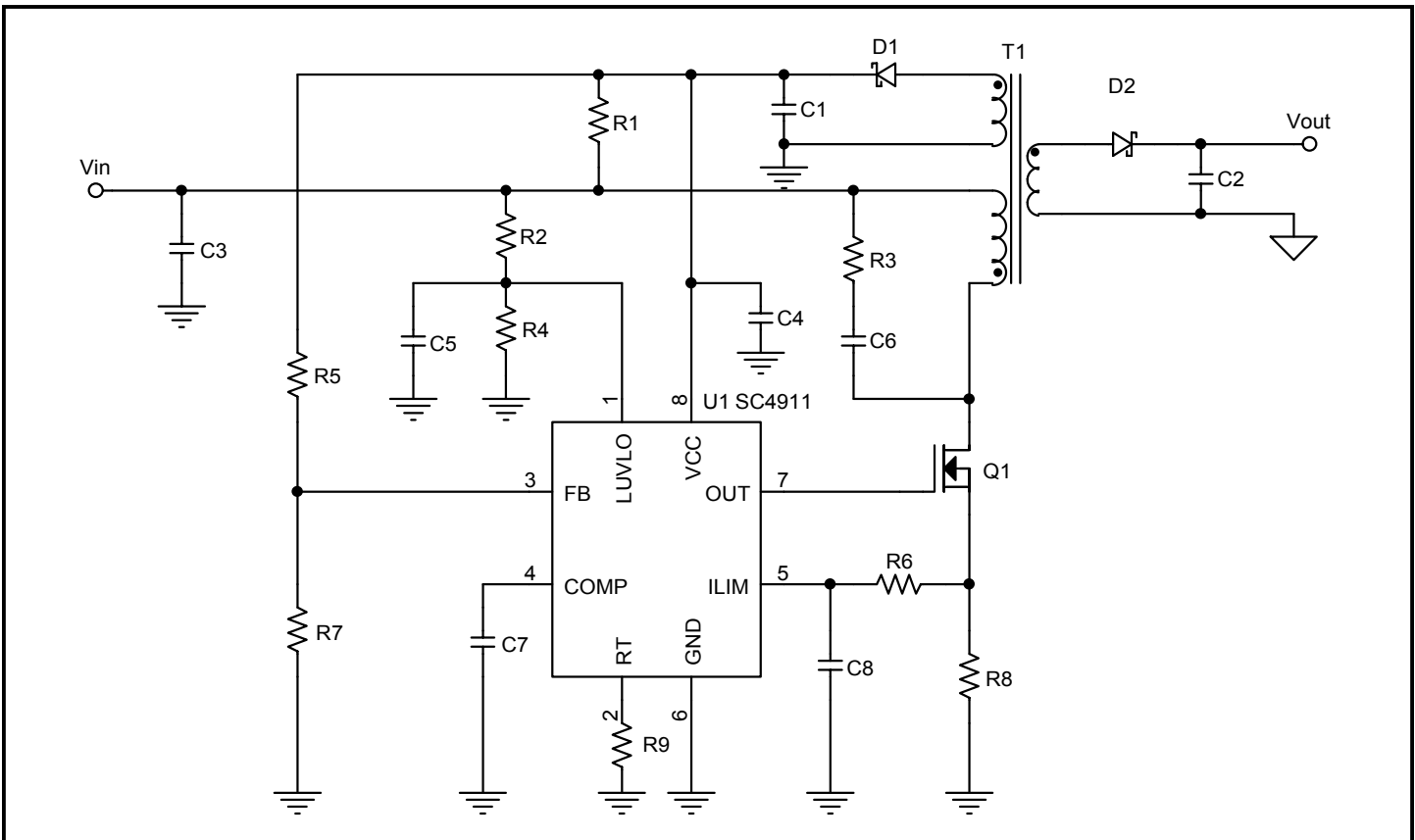

**POWER MANAGEMENT**
**Absolute Maximum Ratings**

Exceeding the specifications below may result in permanent damage to the device, or device malfunction. Operation outside of the parameters specified in the Electrical Characteristics section is not implied.

Parameter	Symbol	Maximum	Units
Supply Voltage	$V_{CC}$	18	V
Supply Current	$I_{CC}$	20	mA
Line UVLO Voltage		$V_{CC}$	V
FB, ILIM and COMP		-0.3 to 6	V
Output Current Source or Sink		250	mA
Storage Temperature Range	$T_{STG}$	-60 to +150	°C
Junction Temperature Range	$T_J$	-40 to +150	°C
Lead Temperature (Soldering) 10 Sec.	$T_{LEAD}$	260	°C
ESD Rating (Human Body Model)	ESD	2	kV

**Electrical Characteristics**

Unless specified:  $T_A = T_J = -40^{\circ}\text{C}$  to  $+125^{\circ}\text{C}$ ,  $V_{CC} = 12\text{V}$ ,  $R_T = 100\text{K}\Omega$ ,  $V_{FB} = 2.4\text{V}$ ,  $LUVLO = 1.5\text{V}$ .

Parameter	Test Conditions	Min	Typ	Max	Unit
<b>Power Supply</b>					
Vcc Turn-On Voltage			6.0	7.0	V
Operating Current	$f_s = 200\text{kHz}$ , No load		3.4	5.0	mA
Startup Current	$LUVLO = 0.6\text{V}$		45	80	$\mu\text{A}$
VCC Zener Shunt Voltage	$I_{CC} = 10\text{mA}$	15	16	17	V
<b>Line UVLO</b>					
Lockout Threshold		1.22	1.25	1.28	V
UVLO Hysteresis			70		mV
Bias Current	$V_{LUVLO} < 1.25\text{V}$		100		nA
<b>Error Amplifier</b>					
Feedback Input Voltage	$V_{CC} = 12\text{V}$	2.44	2.50	2.56	V
Feedback Input Voltage Regulation	$V_{CC} = 7\text{V}$ to $12\text{V}$	2.425		2.575	V
Input Bias Current			170		nA
Amplifier Transconductance			1000		$\mu\text{mho}$
Amplifier Souce Current			500		$\mu\text{A}$
Amplifier Sink Current			600		$\mu\text{A}$
Open Loop Voltage Gain			50		dB

**POWER MANAGEMENT**
**Electrical Characteristics (Cont.)**

Unless specified:  $T_A = T_J = -40^{\circ}\text{C}$  to  $+125^{\circ}\text{C}$ ,  $V_{CC} = 12\text{V}$ ,  $R_T = 100\text{k}\Omega$ ,  $V_{FB} = 2.4\text{V}$ ,  $\text{LUVLO} = 1.5\text{V}$ .

Parameter	Test Conditions	Min	Typ	Max	Unit
<b>Oscillator</b>					
Frequency Range	$R_T = 200\text{k}\Omega$		100		kHz
	$R_T = 43\text{ k}\Omega$		500		
Frequency		170	200	230	kHz
<b>Duty Cycle</b>					
Maximum Duty Cycle		57	65	72	%
Minimum Duty Cycle	$V_{FB} = 3\text{V}$			0	%
<b>Current Limit</b>					
Current Limit Threshold		500	525	550	mV
Propagation Delay to Gate			70		nS
<b>Output</b>					
Output Voltage Low State	Sink 5mA		0.1	0.5	V
Output Voltage High State	Source 5mA	9.5	10.2		V
Rise Time	$C_{OUT} = 100\text{pF}$		25		nS
Fall Time	$C_{OUT} = 100\text{pF}$		10		nS

## POWER MANAGEMENT

### Pin Configuration

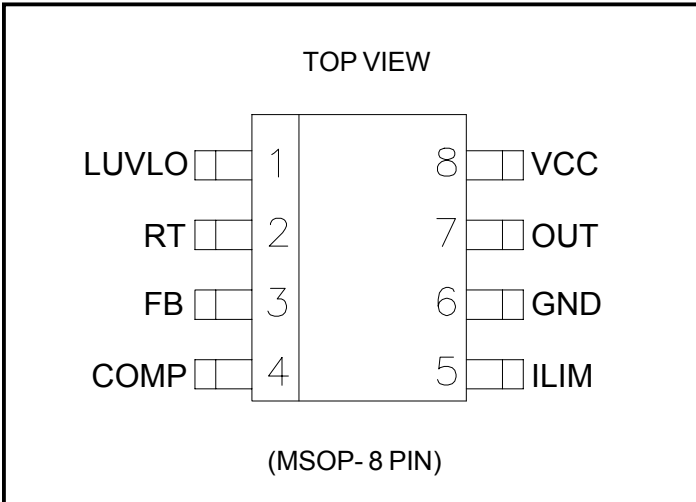

### Ordering Information

Part Number	Package	Temp. Range (T <sub>j</sub> )
SC4911IMSTR	MSOP-8 <sup>(1)</sup>	-40°C to +125°C
SC4911IMSTR <sup>(2)</sup>		

**Notes:**

(1) Only available in tape and reel packaging. A reel contains 2500 devices.

(2) Lead free product. This product is fully WEEE and RoHS compliant.

### Pin Descriptions

Pin #	Pin Name	Pin Function
1	LUVLO	Line under voltage lockout.
2	RT	For programming oscillator frequency.
3	FB	Feedback.
4	COMP	Feedback compensation.
5	ILIM	Current limit sense.
6	GND	Ground.
7	OUT	Gate drive output. Low during UVLO or LUVLO.
8	VCC	Supply voltage.

### Marking Information

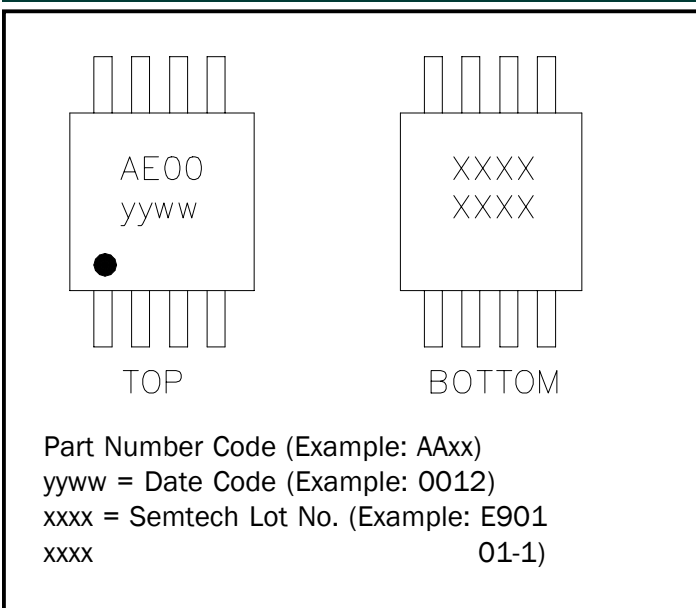

POWER MANAGEMENT

Block Diagram

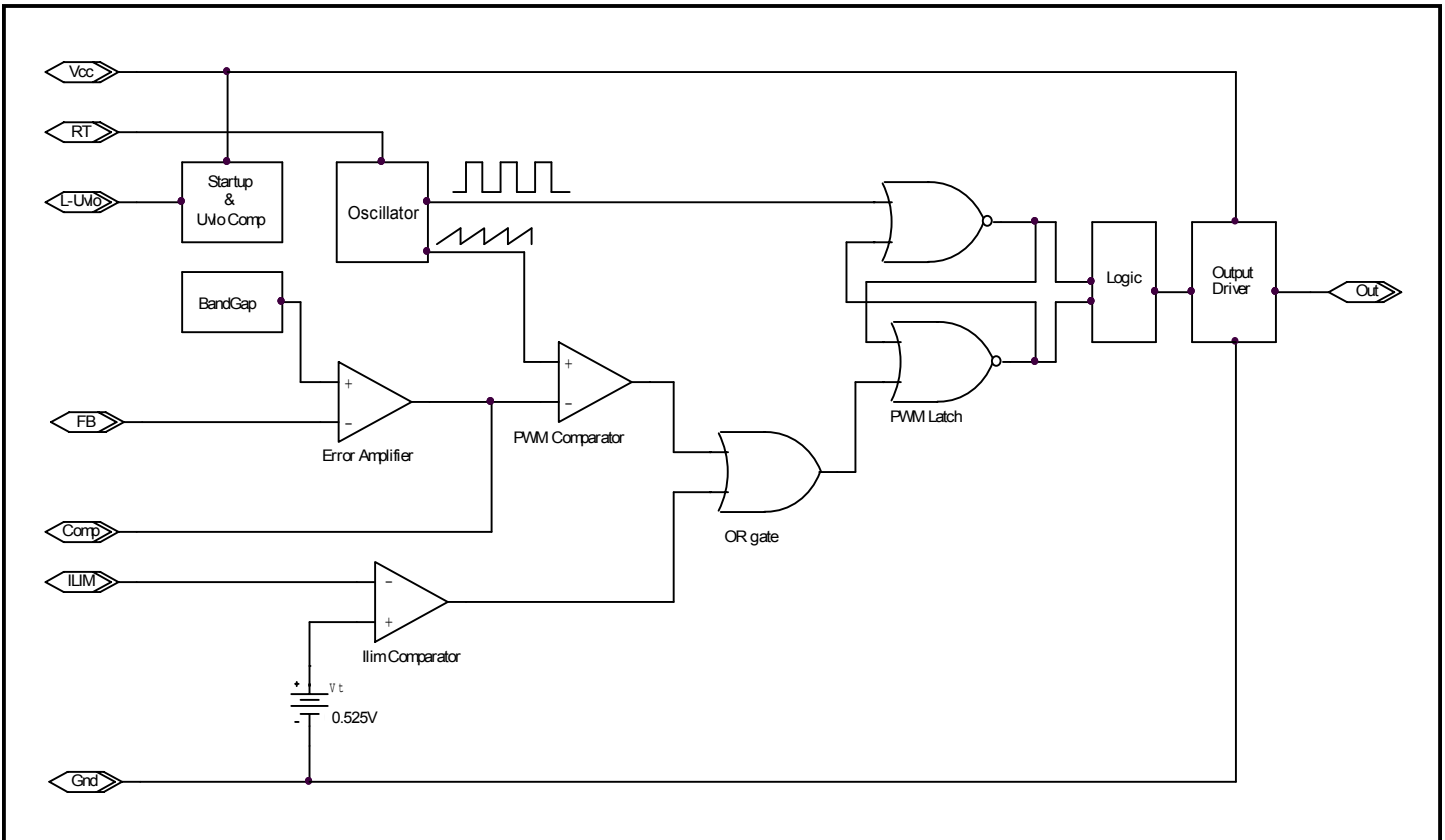

**POWER MANAGEMENT**
**Applications Information**

The SC4911 is a voltage mode controller designed mainly for the isolated or non-isolated flyback converters. As shown in the Block Diagram, it includes start-up circuit, bandgap, error amplifier, PWM comparator, logic and output stage. Line undervoltage has dual functions of line voltage lockout and shutdown. When LUVLO is pull down to ground, the SC4911 is disabled and the quiescent current is reduced to typical 30µA. When it is connected to a resistor voltage divider between input voltage and ground, it monitors the line voltage.

**Oscillator**

The switching frequency of the SC4911 is set by an external resistor connected between RT and GND. Figure 1 shows the relationship between the resistance of the external resistor and the switching frequency.

**Figure 1. Timing Resistor vs Oscillator Frequency**

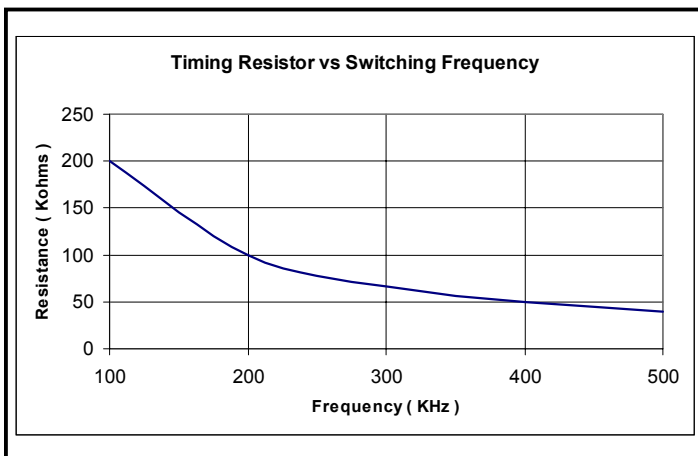
**Line UVLO and VCC UVLO**

The Line UVLO monitors the input line voltage and VCC UVLO monitors the supply voltage to the SC4911. If either input line or VCC is below the lockout threshold, the output is held low and the supply current to the chip is typically 30µA.

A resistor divider from the input line to GND determines the desired undervoltage lockout level. To prevent noise coupling to affect proper UVLO operation, a small capacitor, one hundred to a few hundred pF, is recommended to be used from Line UVLO pin to GND.

**Start-up**

As shown in Typical Applications Circuit on the front page, when input voltage is applied, C1 is trickle charged through the start-up resistor R1 until the SC4911 Vcc reaches the turn-on voltage.

The bias current consumed by the device during this period is only typical 30µA. Once Vcc exceeds the turn-on voltage, OUT starts driving the MOSFET, transferring energy to the secondary and the bias output. If the bias output voltage builds to and is above the Vcc turnoff voltage, the start-up is completed and normal operation begins.

The size of the start-up resistor not only affects power supply start-up time, but also power supply efficiency. The resistor dissipates continuous power in normal operation. Due to ultra low start-up current of the SC4911, large value resistor (several hundred Kohm to 1Mohm) could be used, particularly for off-line applications to improve efficiency considering reasonable start-up time.

**Current Limit**

The current sense resistor is selected by dividing the current sense threshold voltage 0.525V by the primary peak current at the desired current limit point, typically 120% of the primary peak current.

$$R_{\text{SENSE}} = \frac{0.525\text{V}}{1.2 \times I_{\text{PK}}}$$

Care must be taken to ensure proper selection of sense resistor and good layout to prevent erratic operation. The non-inductive resistor must be used as the sense resistor. Parasitic inductance in series with the sense resistor must be minimized. Additional RC filter may be necessary to eliminate the narrow spike time on the leading edge of the primary current. The RC time constant can be chosen to be equal to the time constant of the sense resistor and the parasitic inductance.

**PCB Layout**

Long power supply and ground traces should be avoided. A 0.1µF ceramic capacitor closely placed between Vcc and GND is recommended. The timing resistor used to program switching frequency should be located close to pin RT and pin GND in order to have a stable switching frequency. MOSFET should be located near the device and a resistor in the range of several ohms could be used in series with the gate drive to damp the ringing if the trace between the drive output and MOSFET is not short enough. Star ground connection is recommended to avoid ground loops. The Power path for input filter, MOSFET and transformer should be separated from signal path for timing resistor and feedback resistor, and both should be brought to a single ground point.

**POWER MANAGEMENT**

**Typical Applications**

**48V TO 12V FLYBACK CONVERTER AS AUXILIARY SUPPLY**

Figure 2 shows a simple bias supply using the SC4911. This 36 - 72V input flyback power supply employs primary side regulation from the transformer bias winding, which eliminates the need of opto coupler and secondary reference error amplifier. This is best for low cost applications requiring isolation and narrow load variation range on the secondary.

During the start-up, the input source trickle charges the capacitor C1 through start-up resistor R1. As long as voltage across C1 reaches the Vcc turn-on threshold, the SC4911 turns on abruptly and start driving the gate of MOSFET Q1. After the SC4911 starts up the primary bias winding supplies the primary circuitry.

The output of the T1 bias winding is rectified, filtered by C1 and is fed to the FB through feedback resistor R5 and R7. The output voltage on the secondary is proportional to the bias voltage by the turns ratio of the output to the bias winding. C7 and R9 are for frequency compensation. An additional small capacitor could be used from COMP to GND if it is needed. The LUVLO pin monitors the input voltage via resistor R2 and R4 to determine turn-on and turn-off of the converter. Capacitor C5 helps filter out the noise from the input line.

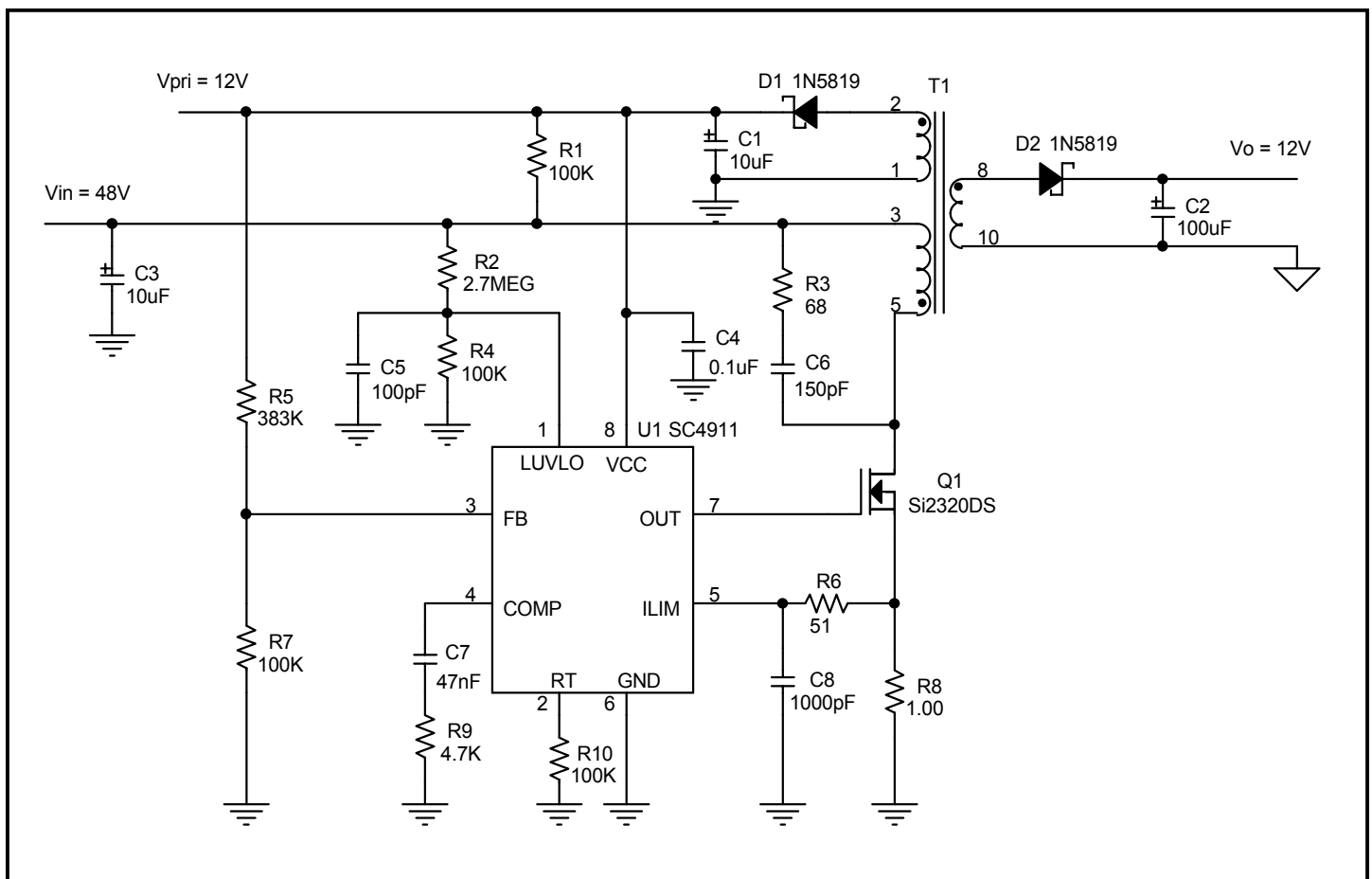

**Figure 2. 48V to 12V Flyback Converter as Auxiliary Supply**



**POWER MANAGEMENT**

**Typical Applications (Cont.)**

**Non-Isolated feedback 48V to 12V application**

Figure 4 is an example of low cost, non-isolated feedback, low power application of the SC4911. T1 is a two winding transformer. The output voltage is directly fed to the primary circuitry.

During the start-up, the input source trickle charges the capacitor C3 through start-up resistor R1. As long as the voltage across C3 reaches the Vcc turn-on threshold, the SC4911 turns on abruptly and starts driving the gate of MOSFET Q1. After the SC4911 starts up the secondary winding supplies the primary circuitry.

In this 36V to 72V telecom application, LUVLO monitors the input voltage via resistor R2 and R4 to determine turn-on and turn-off of the converter. Capacitor C4 helps filter out the noise from the input line. Voltage feedback is directly brought from the output to the input error amplifier of SC4911 through R5 and R7. C6 and R9 are for frequency compensation. An additional small capacitor could be used from COMP to GND if needed.

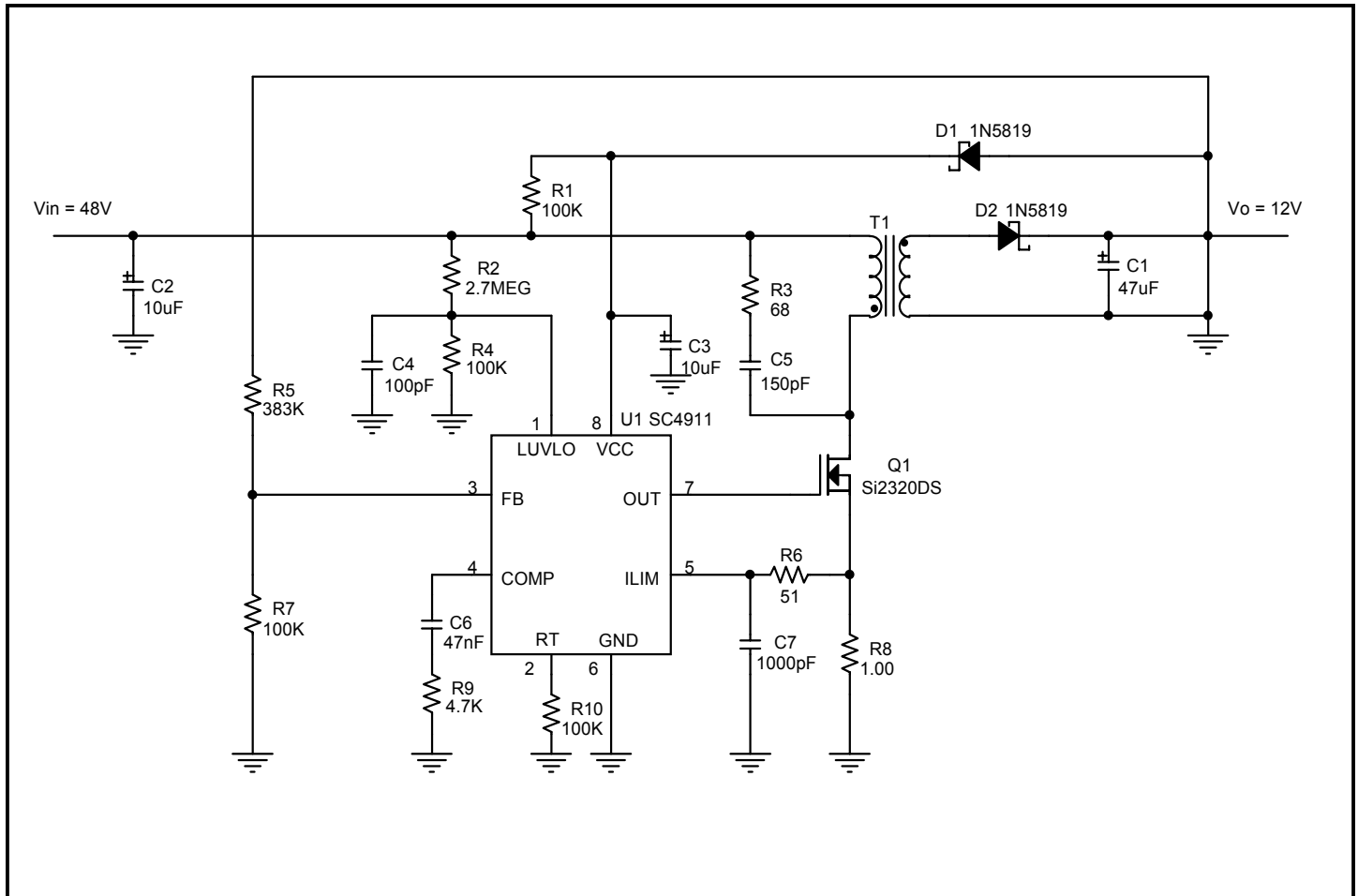

**Figure 4. Non-isolated 48V to 12V Flyback Converter**

**POWER MANAGEMENT**

**Typical Applications (Cont.)**

**48V to 12V FLYBACK CONVERTER AS BATTERY CHARGER**

Figure 5 is another example of non-isolated feedback, low power and compact application of the SC4911 as a battery charger. Battery charging rate is determined by current sense resistor R8. LUVLO is used to not only turn on or turn off the charger by battery charge controller, but also monitors the input line voltage via resistor R2 and R5 to determine turn-on and turnoff of the converter. During the start-up, the input source trickle charges the capacitor C3 through start-up resistor R1. As long as voltage across C3 reaches the Vcc turn-on threshold, the SC4911 turns on abruptly and starts driving the gate of MOSFET Q1. After the SC4911 starts up the secondary winding supplies the primary circuitry.

In this application, voltage feedback is directly brought from the output to the input error amplifier of SC4911 through R4 and R7. C5 and R9 are for frequency compensation.

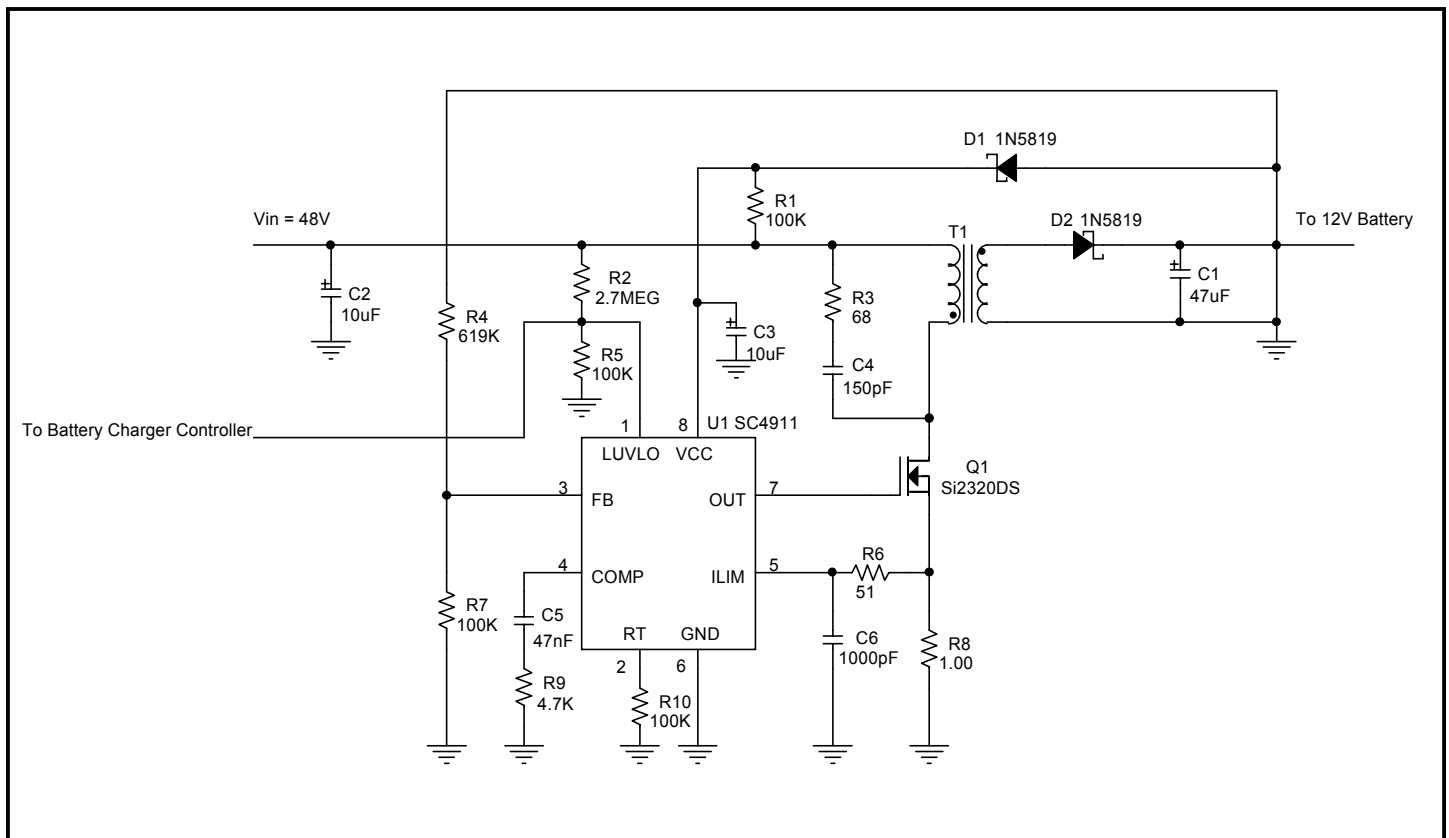

**Figure 5. 48V to 12V Flyback Converter as Battery Charger**

POWER MANAGEMENT

Evaluation Board Schematic

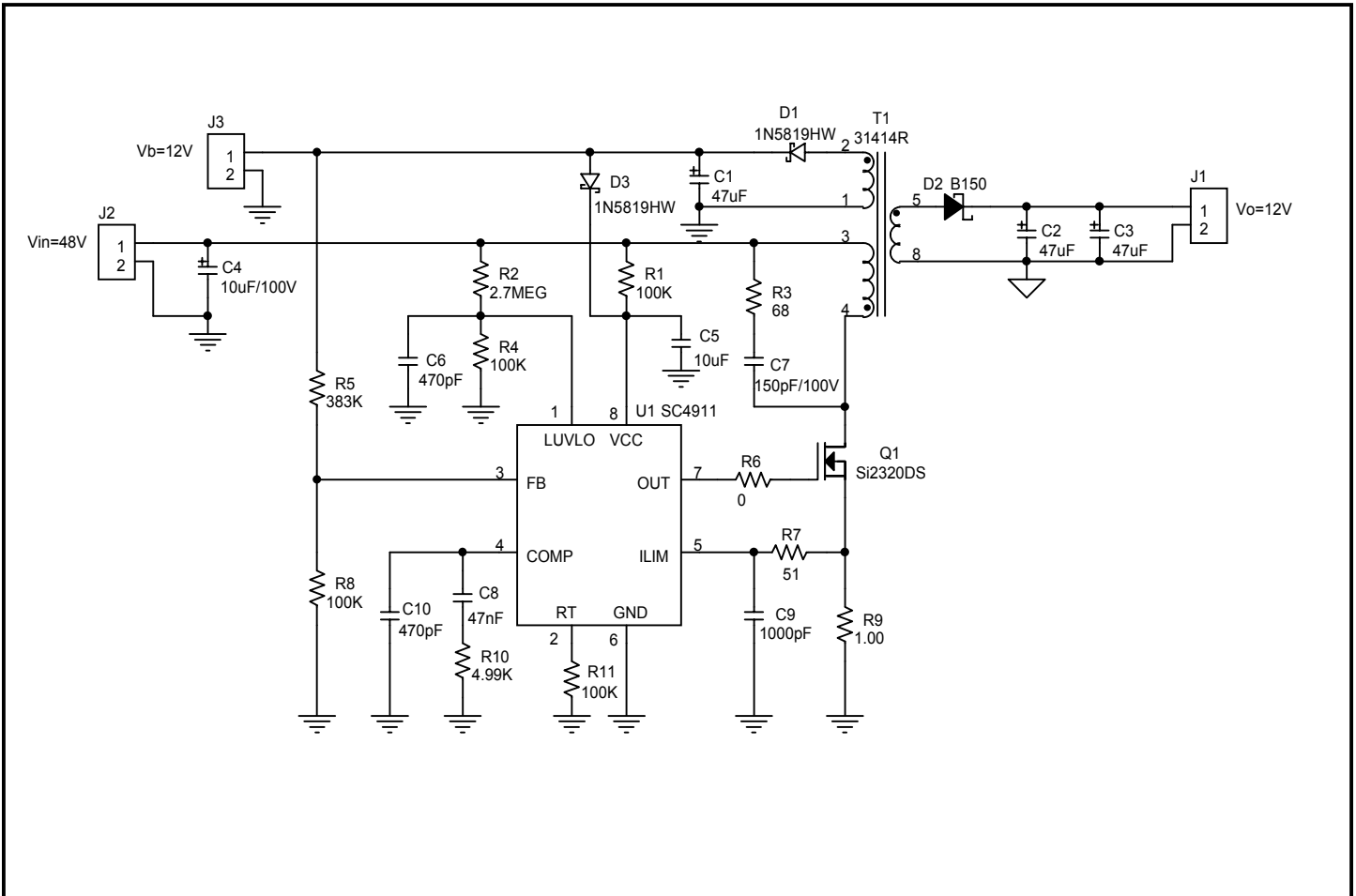

**POWER MANAGEMENT**
**Evaluation Board Schematic- BOM**

Item	Quantity	Reference	Part/Description	Manufacturer #	Foot Print
1	3	C1, C2, C3	47uF	16TPB47M	SM/CT 7343
2	1	C4	10uF/100V	EEU-FC2A100	CYL/D.250/LS.100/.031
3	1	C5	10uF	GRM32ER61C106KC31L	SM/C 1210
4	1	C6	470pF		SM/C 0805
6	1	C7	150pF/100V		SM/C 0805
6	2	C8, C10	47nF		SM/C 0805
7	1	C9	1000pF		SM/C 0805
8	2	D1, D3	1N5819HW		SOD123
9	1	D2	B150-13		SM/SMA
10	1	Q1	Si2320DS	Si2320DS-T1	SOT-23
11	4	R1, R4, R8, R11	100K		SM/R 0805
12	1	R2	2.7 MEG		SM/R 0805
13	1	R3	68		SM/R 0805
14	1	R5	383K		SM/R 0805
15	1	R6	0		SM/R 0805
16	1	R7	51		SM/R 0805
17	1	R9	1		SM/R 0805
18	1	R10	4.99K		SM/R 0805
19	1	T1	31414R	MIDCOM	31414R
20	1	U1	SC4911IMSTR	Semtech Corp. 805-498-2111	MSOP-8

POWER MANAGEMENT

Typical Characteristics

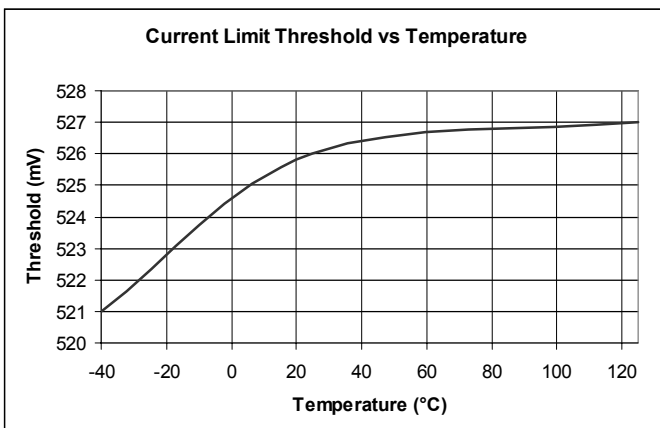
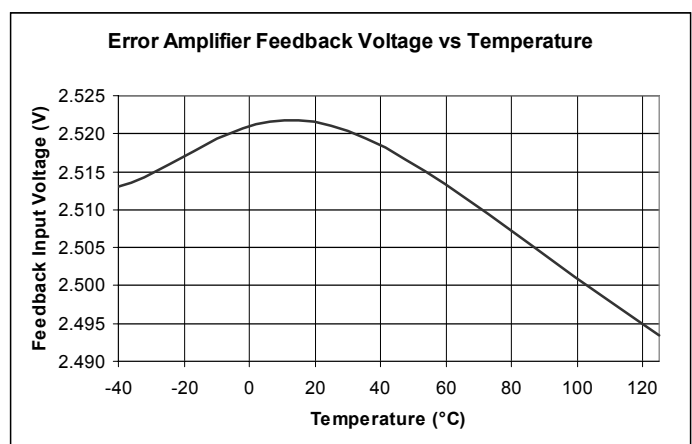
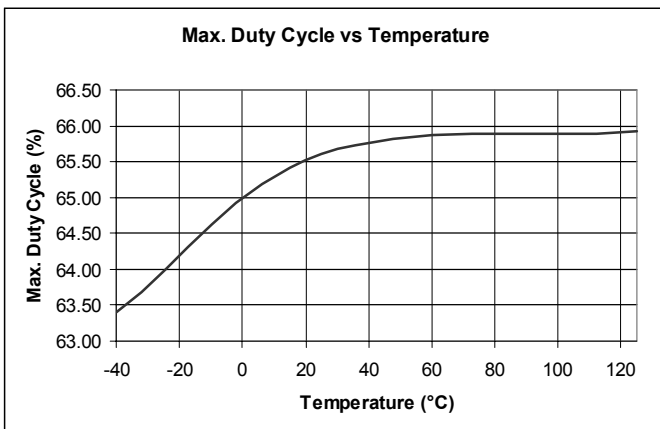
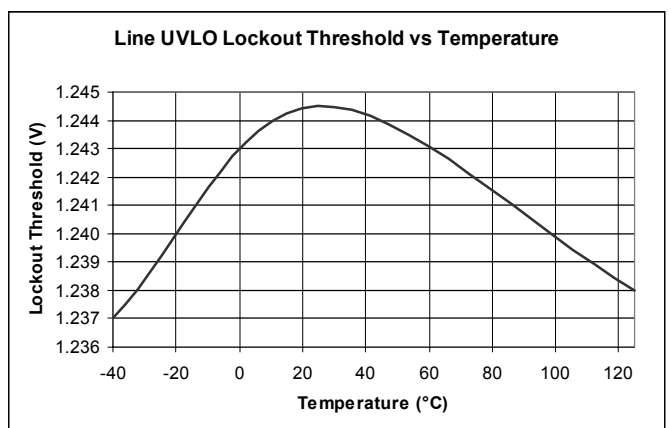
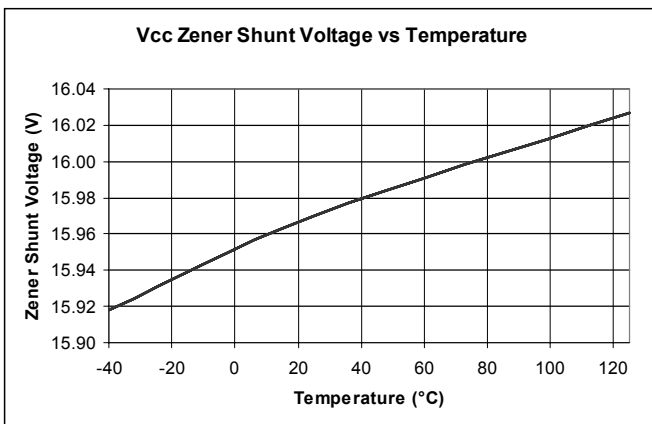
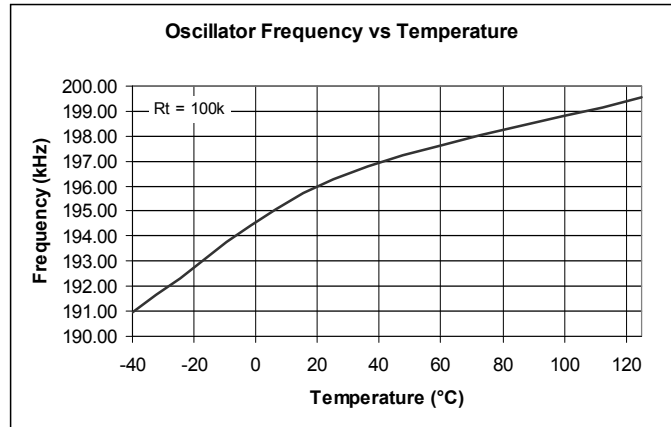
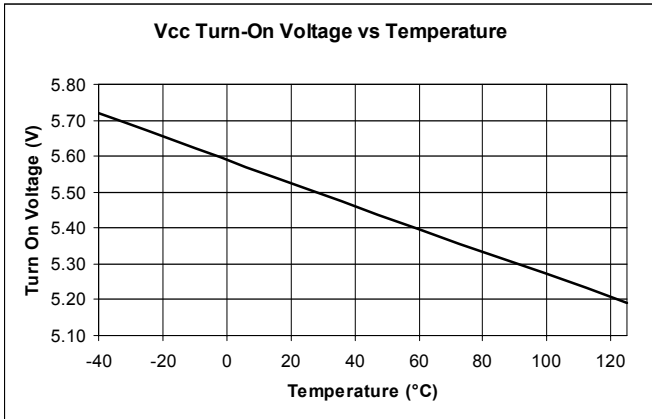

**POWER MANAGEMENT**

**Outline Drawing - MSOP-8**

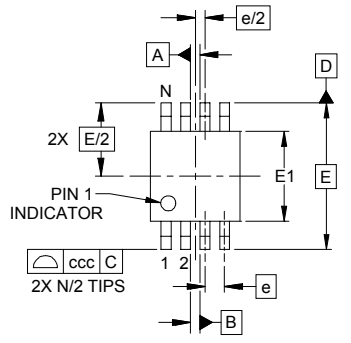

DIM	INCHES			MILLIMETERS		
	MIN	NOM	MAX	MIN	NOM	MAX
A	-	-	.043	-	-	1.10
A1	.000	-	.006	0.00	-	0.15
A2	.030	-	.037	0.75	-	0.95
b	.009	-	.015	0.22	-	0.38
c	.003	-	.009	0.08	-	0.23
D	.114	.118	.122	2.90	3.00	3.10
E1	.114	.118	.122	2.90	3.00	3.10
E	.193 BSC			4.90 BSC		
e	.026 BSC			0.65 BSC		
L	.016	.024	.032	0.40	0.60	0.80
L1	(.037)			(.95)		
N	8			8		
θ1	0°	-	8°	0°	-	8°
aaa	.004			0.10		
bbb	.005			0.13		
ccc	.010			0.25		

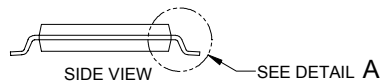
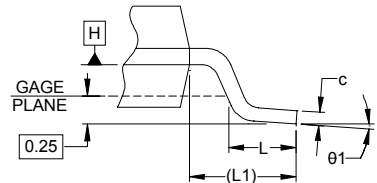
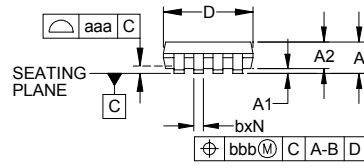

NOTES:

1. CONTROLLING DIMENSIONS ARE IN MILLIMETERS (ANGLES IN DEGREES).
2. DATUMS [-A-] AND [-B-] TO BE DETERMINED AT DATUM PLANE [-H-]
3. DIMENSIONS "E1" AND "D" DO NOT INCLUDE MOLD FLASH, PROTRUSIONS OR GATE BURRS.
4. REFERENCE JEDEC STD MO-187, VARIATION AA.

**Land Pattern - MSOP-8**

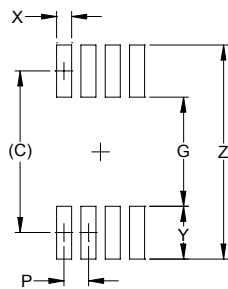

DIM	DIMENSIONS	
	INCHES	MILLIMETERS
C	(.161)	(4.10)
G	.098	2.50
P	.026	0.65
X	.016	0.40
Y	.063	1.60
Z	.224	5.70

NOTES:

1. THIS LAND PATTERN IS FOR REFERENCE PURPOSES ONLY. CONSULT YOUR MANUFACTURING GROUP TO ENSURE YOUR COMPANY'S MANUFACTURING GUIDELINES ARE MET.

**Contact Information**

Semtech Corporation  
 Power Management Products Division  
 200 Flynn Road, Camarillo, CA 93012  
 Phone: (805)498-2111 FAX (805)498-3804

## Looking for pricing, stock, or lifecycle information?

Click below to explore more details on WIN SOURCE:

 [View SC4911IMSTRT on WIN SOURCE](#)

 [Semtech Corporation](#) Information

## Optimize Your Supply Chain with WIN SOURCE Solutions

-  Global Sourcing Solution
-  Obsolete Management
-  Cost Control Management
-  Shortage Management
-  Alternative Solution
-  Excess Inventory Management