



**THE DATASHEET OF
QR/P17-SCA-111(50)**



Rectangular, Multiple-Position Rack/Panel Insulation Displacement Connectors (IDC)

QR/P18 Series

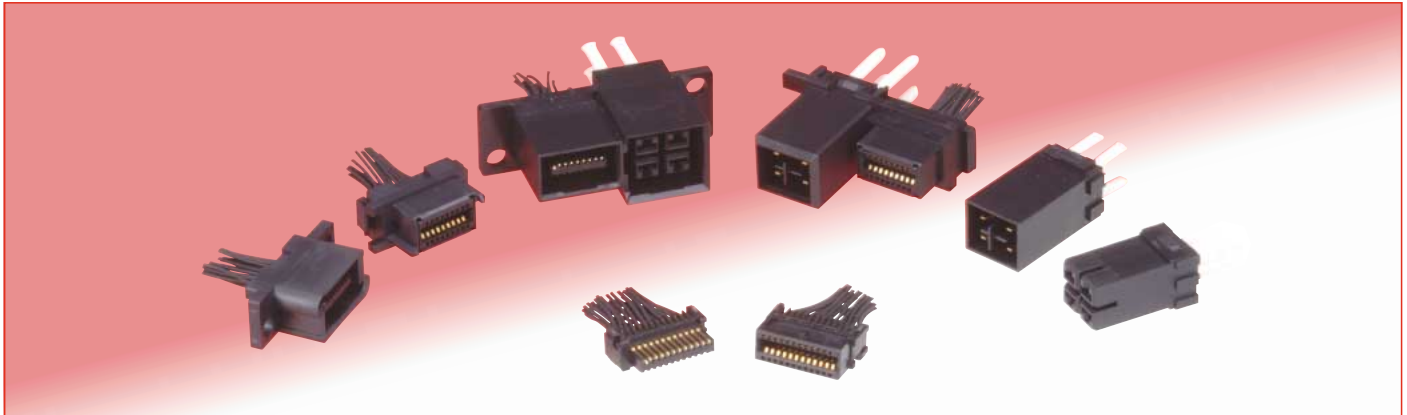

Overview

The QR/P18 Series of miniature rack/panel connectors is designed for the complete segmentation of the structure of the external holder/terminal units of the well-received QR/P Series of plug-in rectangular rack/panel connectors; furthermore, the subsequent insertion of the harnessed terminal unit affords a more efficient harness mounting task. These connectors are configured with 12, 18, or 24 (insulation displacement connection) positions in the signal portion, and 4 (crimp) positions in the power supply portion.

Features

1. Completely segmented structure of the external holder/terminal unit

In order to improve the harness mounting task, the connectors are designed for the complete segmentation of the external holder and the signal/power supply unit, and the method of subsequently inserting harnessed products aims to improve the workability of the power supply/signal section harness as well as the mounting of the set.

2. Signal unit

The signal unit uses the highly reliable insulation displacement connection method. (The wire is AWG #26 and the insulation outside diameter is 0.88 mm.)

The insulation displacement task can now be used by fitting a special applicator to a commercially available automatic insulation displacement machine, or a manual press can also be selected.

3. Power supply portion

The power supply terminals permit the use of a crimp harness using wire of AWG #16 to 18 (and insulation outside diameter of 2.1 to 2.2 mm), and can accommodate a maximum of 12 A.

4. Sequenced structure

Connectors possess two sequenced contacts in the signal male unit and one sequenced contact in the power supply female unit making them perfect in terms of safety too.

5. Panel installation

Installation to a panel uses a single-action method on the anchored side and a floating screw structure on the floating side which permits smooth insertion and disconnection without forcing.

6. RoHS compliant

All components and materials comply with the requirements of the EU Directive 2002/95/EC.

*A portion of this series is suitably constructed for high-speed differential transfer, and using a suitable cable, transfer of 2.5Gbps per pair is possible.

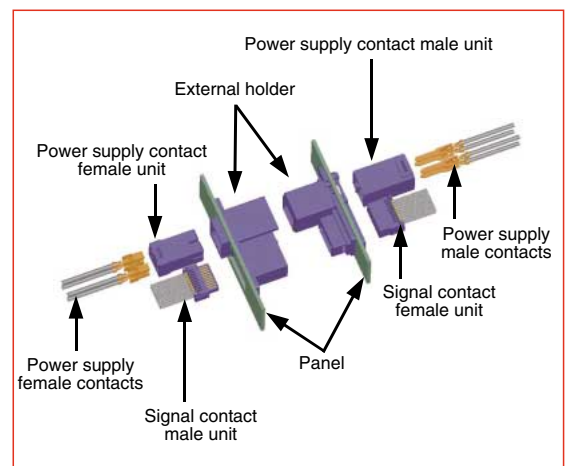

2.5 Gbps Eye Pattern Waveform

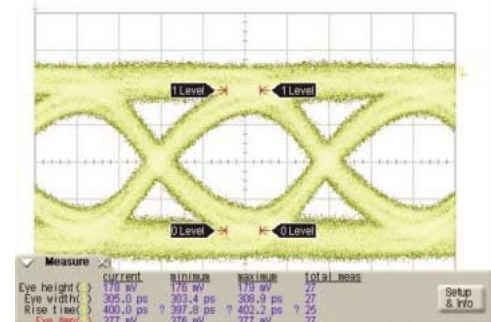

2.5Gbps Scale
 AWG28 2m X : 100psec/div
 Y : 100V/div

Applications

PPC, transmitting and receiving devices, data communications equipment, vending machines, measuring instruments, factory automation equipment, and other high-speed transfer applications, etc.

■Product Specifications

| | | | | |
|---------|----------------|--------------------------------------------------------|-----------------------------|-----------------------------|
| Ratings | Voltage rating | 125 V AC (Signal contacts) 300V AC (Power contacts) | Operating temperature range | -40°C to +105°C (Note 1) |
| | Current rating | 1A (Signal contacts) 12A (Power contacts) | | |

| Item | Specification | Conditions |
|------------------------------------|-----------------------------------------------------------------------------------------------------------------------------------------------|----------------------------------------------------------------------------------------------------------------|
| 1. Contact resistance | 50mΩ max. (Signal contacts) (Note 2) 10mΩ max. (Power contacts) (Note 2) | 100 mA |
| 2. Insulation resistance | 1000MΩ min. (Signal contacts) 5000MΩ min. (Power contacts) | 500 V DC |
| 3. Withstanding Voltage | No flashover or insulation breakdown. | 500 V AC / one minute |
| 4. Durability (mating / un-mating) | Contact resistance: 70mΩ max. (Signal contacts) 20mΩ max. (Power contacts) | 3000 cycles |
| 5. Vibration | No electrical discontinuity of 10μs or more. No damage, cracks, or parts dislocation. | Frequency: 10 to 55 Hz, single amplitude of 0.75 mm, 2 hours in each of the 3 axis. |
| 6. Shock | | Acceleration of 490 m/s ² , 11 ms duration, sine half-wave waveform, 3 cycles in each of the 3 axis |
| 7. Temperature cycle | Contact resistance: 70mΩ max. (Signal contacts) 20mΩ max. (Power contacts) No damage, cracks, or parts dislocation. | Temperature: -55°C→+5°C to +35°C→+105°C→+5°C to +35°C Time: 30→5→30→5 (Minutes) 5 cycles |
| 8. Humidity (Steady state) | Insulation resistance: 100MΩ min. (Signal contacts, state) 3000MΩ min. (Power contacts, state) No damage, cracks, or parts dislocation. | 96 hours at 40°C and RH 90% to 95% |
| 9. Salt mist | No corrosions. | 5% salt water solution for 48 hours |

Note1: Includes temperature rise caused by current flow.

Note2: Excludes wire conductor resistance.

■Materials

| Products | Components | Material | Finish | Remarks |
|-----------------------|-----------------|-----------------|---------------------------------|---------|
| External holder | Insulator | PBT | ———— | UL94V-0 |
| | Insulator | PA | ———— | UL94V-0 |
| Signal contact unit | Female contacts | Phosphor bronze | Gold plated | ———— |
| | Male contacts | Phosphor bronze | Gold plated | ———— |
| Power contact unit | Insulator | PBT | ———— | UL94V-0 |
| | Female contacts | Phosphor bronze | Gold plated | ———— |
| | Male contacts | Phosphor bronze | Gold plated | ———— |
| Power supply contacts | Female contacts | Copper alloy | Gold plated + Tin copper plated | ———— |
| | Male contacts | Copper alloy | Gold plated + Tin copper plated | ———— |

■Function Diagram

●Power supply/signal combination type

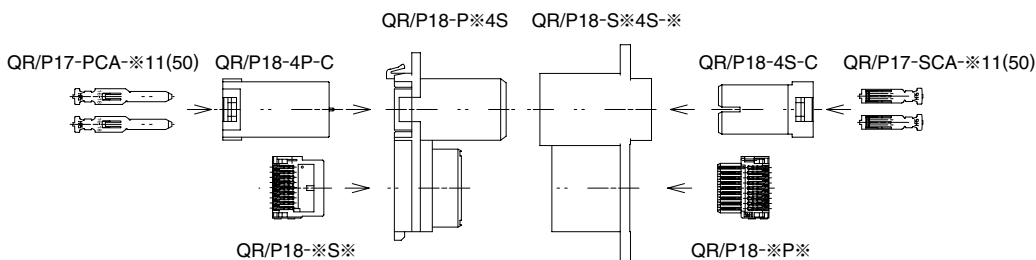

●Signal type

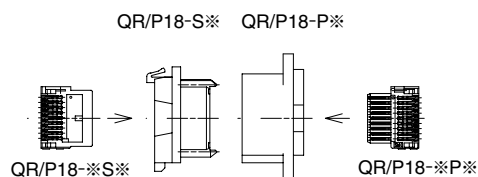

■ Ordering information

● External holder.

QR / P18 - S A 4 P - A
 ① ② ③ ④ ⑤ ⑥

| | |
|-----------------------------------------------------------------------------------------------------------------------------------------------------------|--------------------------------------------------------------|
| ① Series name | ④ Number of power contact |
| ② Signal contact type S: Female contact P: Male contact | ⑤ Power contact type S: Female contact P: Male contact |
| ③ Number of signal contact of external holder A: 12 pos. (Contact pitch 1.5mm) B: 18 pos. (Contact pitch 1.5mm) C: 24 pos. (Contact pitch 1.5mm) | ⑥ Applicable panel thickness A: 2mm B: 1.5mm |

● Signal contact termination block

QR / P18 - 12 S A
 ① ② ③ ④

| | |
|---------------------------------------------------------------|----------------------------------------------------------------------------------------------------------------------------------------------------------------------------|
| ① Series name | ④ Number of signal contact of signal contact termination block A: 12 pos. (Contact pitch 1.5mm) B: 18 pos. (Contact pitch 1.5mm) C: 24 pos. (Contact pitch 1.5mm) |
| ② Number of signal contact | |
| ③ Signal contact type S: Female contact P: Male contact | |

● Power contact insert

QR / P18 - 4 P - C
 ① ② ③ ④

| | |
|--------------------------------------------------------------|--------------------------------------|
| ① Series name | ④ Connector type C: Crimp housing |
| ② Number of power contact | |
| ③ Power contact type S: Female contact P: Male contact | |

● Power contact

QR / P17 - PC A - 1 1 1
 ① ② ③ ④ ⑤ ⑥

| | |
|----------------------------------------------------------------------------|-------------------------------------------------------|
| ① Series name | ④ Packaging 1: Pack packaging 2: Reel packaging |
| ② Power contact type PC: Male crimp contact SC: Female crimp contact | |
| ③ Applicable wire style A: UL1015 | ⑤ Applicable wire 1: AWG#16 to 18 |
| | ⑥ Contact plating 1: Gold plated |

External holder



Mated condition (Shown for reference)

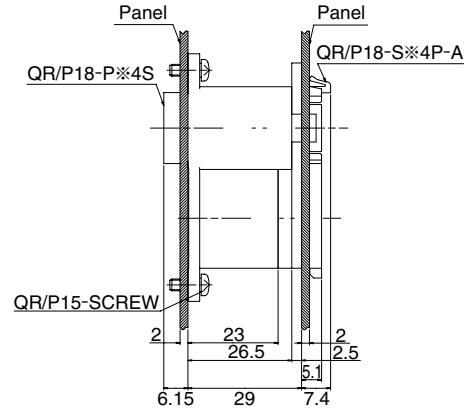

Note: Establish panel mounting so that the mating gap dimensions of the power supply side and the signal side are 1.5 mm or less.

Female power contact, male signal contact type

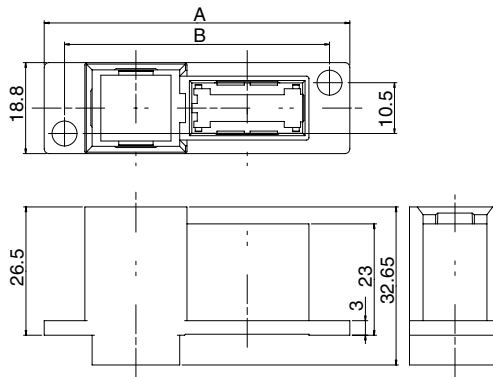

Panel cutout

Applicable panel thickness: 2.0mm

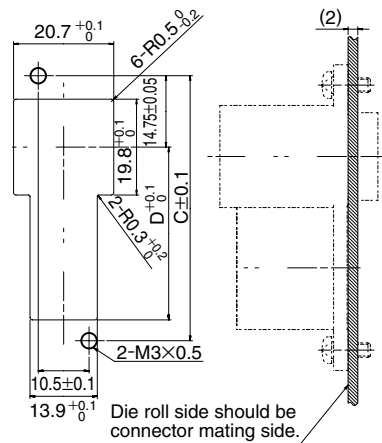

| Part number | CL No. | Number of contacts | | A | B | C | D | RoHS |
|-------------|--------------|--------------------|-------|-------|-------|-------|------|------|
| | | Signal | Power | | | | | |
| QR/P18-PA4S | CL221-0293-8 | 12 | 4 | 54.65 | 46.25 | 46.25 | 27.2 | YES |
| QR/P18-PB4S | CL221-0313-3 | 18 | 4 | 58.65 | 50.25 | 50.25 | 31.2 | |
| QR/P18-PC4S | CL221-0297-9 | 24 | 4 | 63.15 | 54.75 | 54.75 | 35.7 | |

Panel attachment screw (QR/P15-SCREW CL221-0251-8) is optional.



●Male power contact, female signal contact type

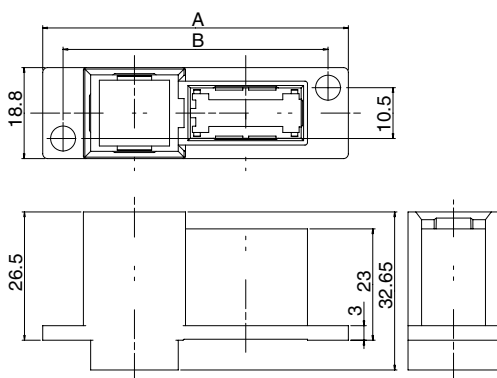

Panel cutout

Applicable panel thickness: 2.0mm

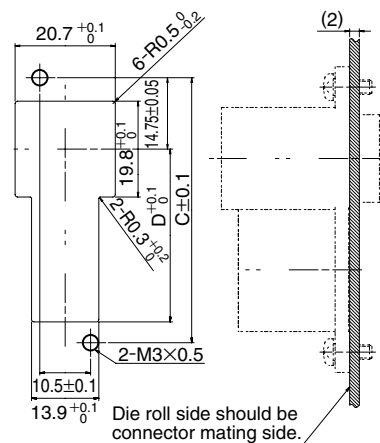

| Part number | CL No. | Number of contacts | | A | B | C | D | RoHS |
|---------------|--------------|--------------------|-------|-------|------|-------|------|------|
| | | Signal | Power | | | | | |
| QR/P18-SA4P-A | CL221-0294-0 | 12 | 4 | 43.85 | 37.9 | 27.25 | 17.3 | YES |
| QR/P18-SB4P-A | CL221-0315-9 | 18 | 4 | 47.85 | 41.9 | 31.25 | 21.3 | |
| QR/P18-SC4P-A | CL221-0298-1 | 24 | 4 | 52.35 | 46.4 | 35.75 | 25.8 | |

External holder (Signal type)



Mated condition (Shown for reference)

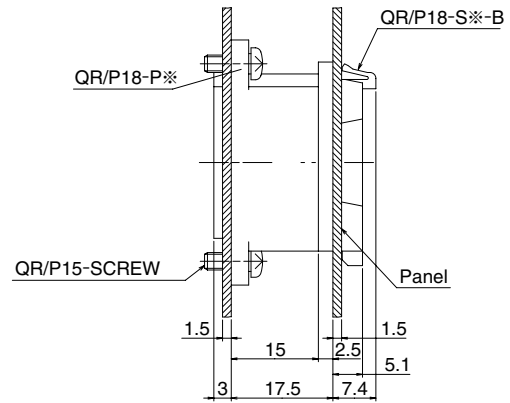

Note: Establish panel mounting so that the mating gap dimensions of the power supply side and the signal side are 1.5 mm or less.

Male signal contact type

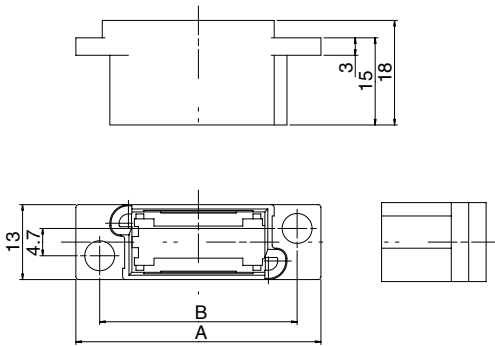

Panel cutout Applicable panel thickness: 1.5mm

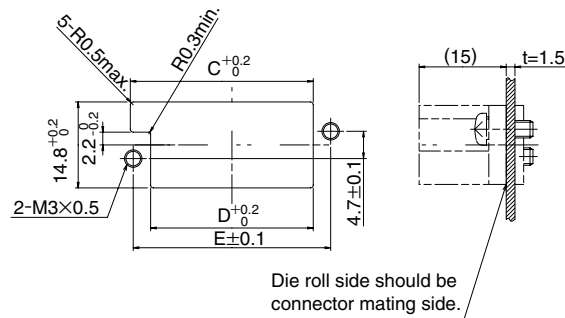

| Part number | CL No. | Number of contacts | A | B | C | D | E | RoHS |
|-------------|--------------|--------------------|------|------|------|------|------|------|
| | | Signal | | | | | | |
| QR/P18-PB | CL221-0309-6 | 18 | 37.7 | 29.5 | 27.0 | 23.5 | 29.5 | YES |
| QR/P18-PC | CL221-0311-8 | 24 | 42.2 | 34.0 | 31.5 | 28.0 | 34.0 | |

Panel attachment screw (QR/P15-SCREW CL221-0251-8) is optional.

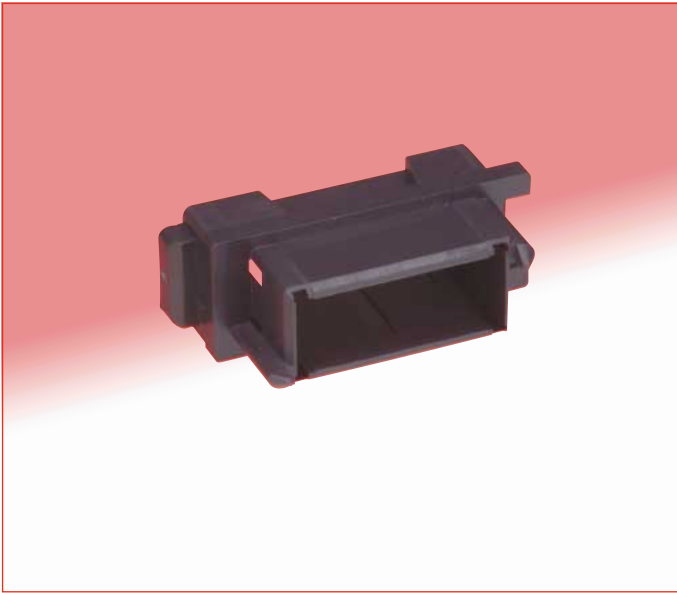

●Female signal contact type

Panel cutout Applicable panel thickness: 1.5mm

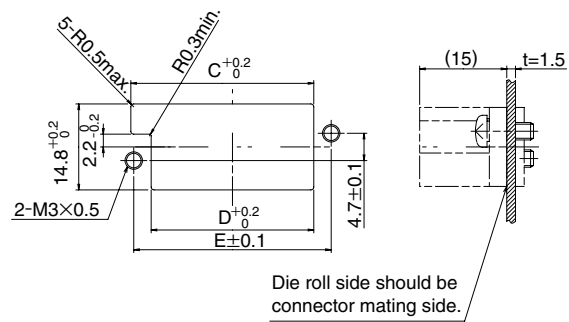
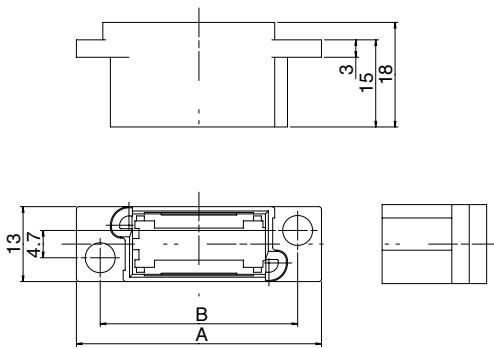

| Part number | CL No. | Number of contacts | A | B | C | D | RoHS |
|-------------|--------------|--------------------|-------|------|-------|------|------|
| | | Signal | | | | | |
| QR/P18-SB-B | CL221-0310-5 | 18 | 28.05 | 25.1 | 13 | 7.3 | YES |
| QR/P18-SC-B | CL221-0312-0 | 24 | 32.55 | 29.6 | 15.25 | 11.8 | |

■Signal contact termination block

●Male, contact pitch 1.5mm

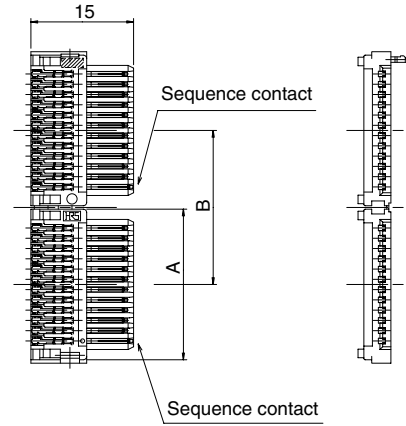
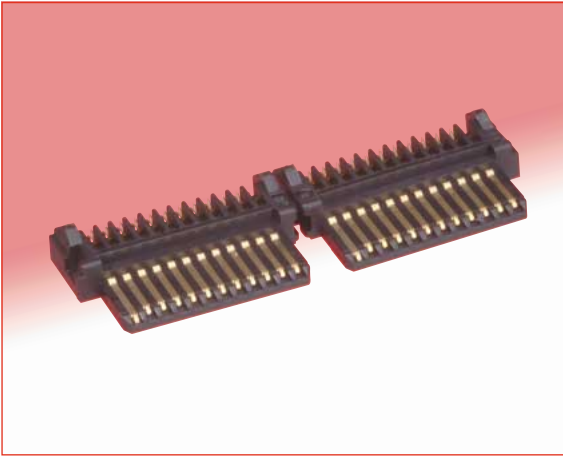

| Part number | CL No. | Number of contacts | A | B | RoHS |
|-------------|--------------|--------------------|------|------|------|
| QR/P18-12PA | CL221-0291-2 | 12 | 13.5 | 14 | YES |
| QR/P18-18PB | CL221-0285-0 | 18 | 17.5 | 18 | |
| QR/P18-24PC | CL221-0295-3 | 24 | 22 | 22.5 | |

Adscable cable: AWG#26, insulator diameter 0.88mm

●Female, contact pitch 1.5mm

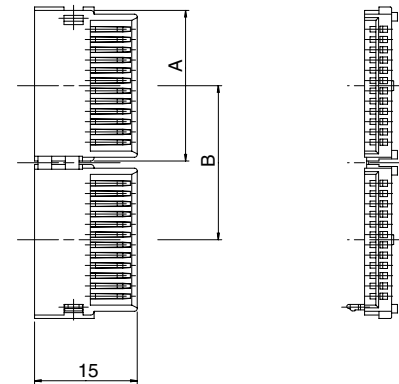
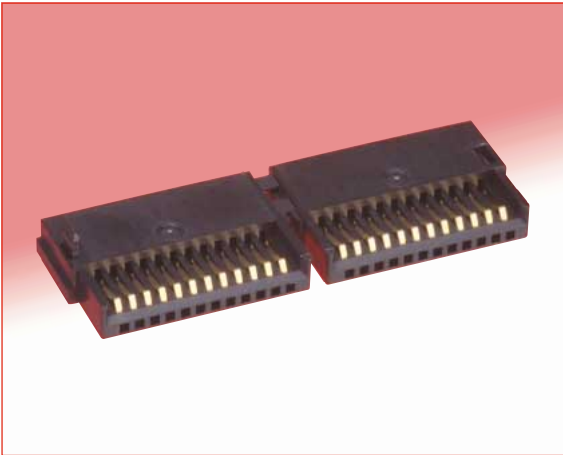

| Part number | CL No. | Number of contacts | A | B | RoHS |
|-------------|--------------|--------------------|------|------|------|
| QR/P18-12SA | CL221-0292-5 | 12 | 13.5 | 14 | YES |
| QR/P18-18SB | CL221-0286-2 | 18 | 17.5 | 18 | |
| QR/P18-24SC | CL221-0296-6 | 24 | 22 | 22.5 | |

Applicable cable: AWG#26, insulator diameter 0.88mm

■ Power contact insert

● Male

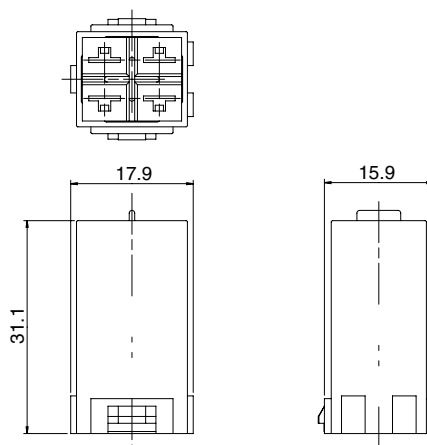

| Part number | CL No. | RoHS |
|-------------|--------------|------|
| QR/P18-4P-C | CL221-0316-1 | YES |

● Female

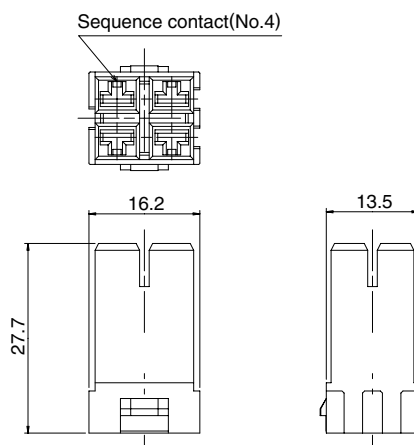
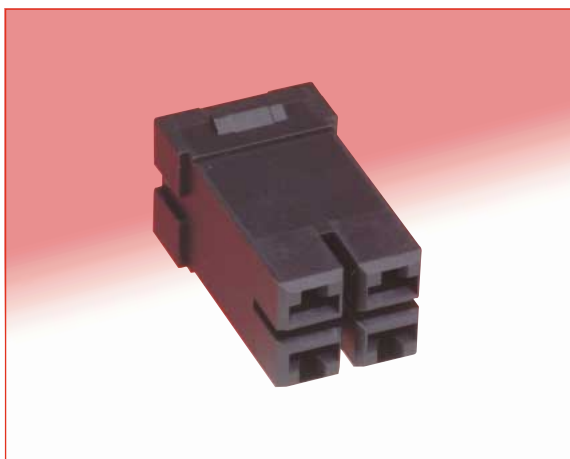

| Part number | CL No. | RoHS |
|-------------|--------------|------|
| QR/P18-4S-C | CL221-0314-6 | YES |

■ Power contact

● Male contact

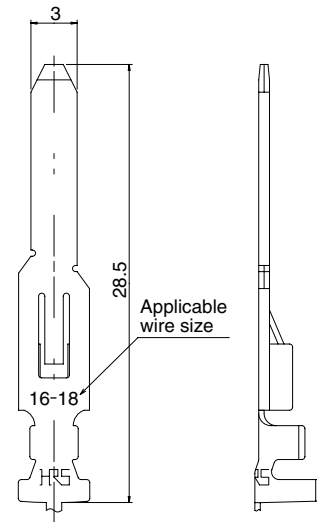
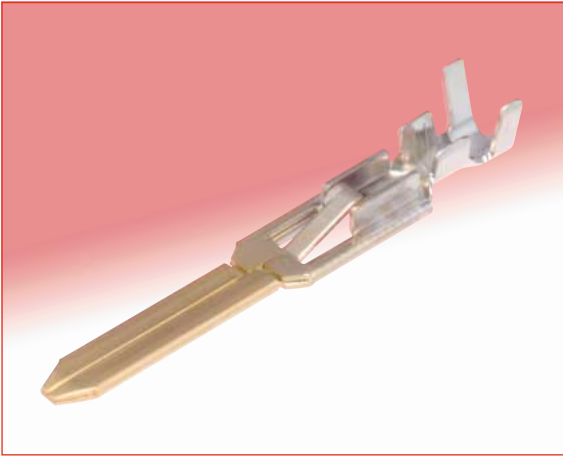

| Part number | CL No. | Applicable cable | Packaging | Q'ty | RoHS |
|--------------------|-----------------|------------------|-----------|------|------|
| QR/P17-PCA-111(50) | CL221-0265-2-50 | AWG16~18 UL1015 | Bag | 100 | YES |
| QR/P17-PCA-211(50) | CL221-0263-7-50 | AWG16~18 UL1015 | Reel | 3000 | |

Applicable cable: AWG#16 to 18, insulator diameter 2.1mm to 3.2mm

● Female contact

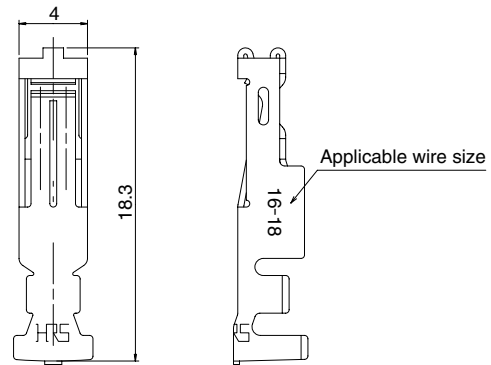
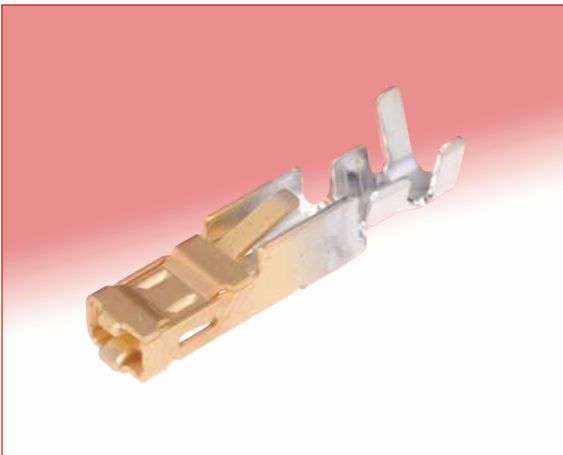

| Part number | CL No. | Applicable cable | Packaging | Q'ty | RoHS |
|--------------------|-----------------|------------------|-----------|------|------|
| QR/P17-SCA-111(50) | CL221-0264-0-50 | AWG16~18 UL1015 | Bag | 100 | YES |
| QR/P17-SCA-211(50) | CL221-0262-4-50 | AWG16~18 UL1015 | Reel | 3000 | |

Applicable cable: AWG#16 to 18, insulator diameter 2.1mm to 3.2mm

◆Tools

●Signal contact termination block IDC tool

| Type | Part number | Applicable connector |
|----------------------------------------------------|-------------------|----------------------|
| Hand press for 12 pos. | QR/P18-12/IDCR-MP | QR/P18-12PA |
| | | QR/P18-12SA |
| Hand press for 18 pos. | QR/P18-18/IDCR-MP | QR/P18-18PB |
| | | QR/P18-18SB |
| Hand press for 24 pos. | QR/P18-24/IDCR-MP | QR/P18-24PC |
| | | QR/P18-24SC |
| Automatic IDC applicator for male signal contact | 2957-1000 | QR/P18-12PA |
| | | QR/P18-18PB |
| | | QR/P18-24PC |
| Automatic IDC applicator for female signal contact | 2957-1500 | QR/P18-12SA |
| | | QR/P18-18SB |
| | | QR/P18-24SC |

Automatic IDC machine (Murata kogyo co., Ltd., P/N MS-01) is available.

●Power contact crimp tool

| Type | Part number | Applicable contact |
|----------------------------------------|----------------|--------------------|
| Hand tool | HT104/QR/P17-1 | QR/P17-PCA-111(50) |
| | | QR/P17-SCA-111(50) |
| Applicable for automatic crimp machine | AP105-QR/P17-1 | QR/P17-PCA-211(50) |
| | AP105-QR/P17-1 | QR/P17-SCA-211(50) |
| Automatic crimp machine | CM-105 | QR/P17-PCA-211(50) |
| | | QR/P17-SCA-211(50) |
| Extraction tool | QR/P17-TC | QR/P17-PCA-111(50) |
| | | QR/P17-SCA-111(50) |
| | | QR/P17-PCA-211(50) |
| | | QR/P17-SCA-211(50) |

■ Inspection After Cable Wiring

● Signal contact unit

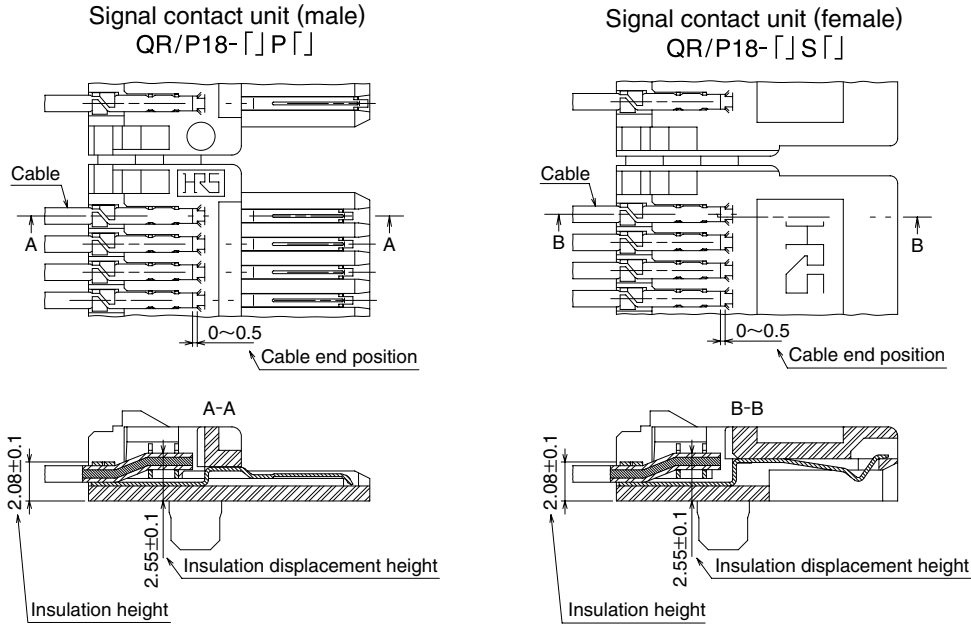

- (1) After wiring the cable, examine the cable end position, the insulation displacement height, and the insulation height.
- (2) In examining the insulation displacement height and the insulation height, use a measurement pin having a tip of 0.5 mm diameter.
- (3) For information about the detailed inspection method, please request the "Inspection Standards Manual" from Hirose Electric.
- (4) The inspection method of the diagrams is for cable with AWG #26 wire and an insulation outside diameter of 0.88 mm.

● Power supply contacts

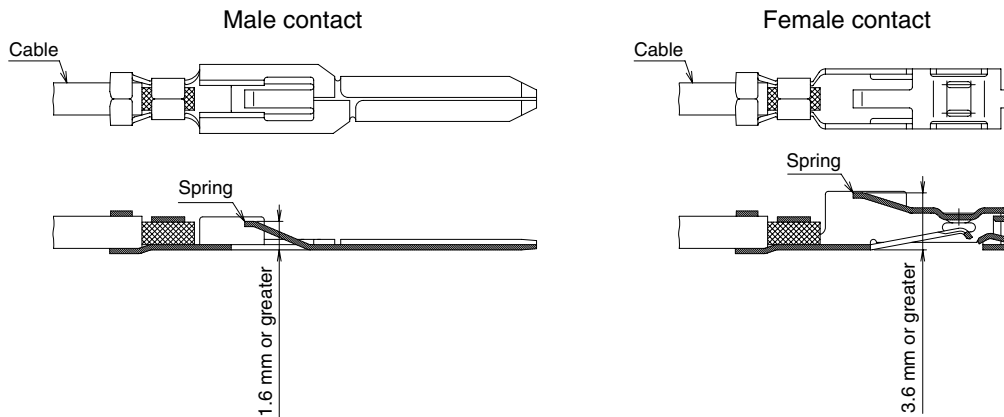

Before inserting the power supply contacts into the power supply terminal unit, check that the spring portion illustrated in the diagram is not misshapen.

When the spring portion is less than the dimensions indicated in the diagram, the spring could pull out from the power supply terminal unit; therefore, the specified dimensions should be maintained.



HIROSE ELECTRIC CO.,LTD.

5-23,OSAKI 5-CHOME,SHINAGAWA-KU,TOKYO 141-8587,JAPAN
 PHONE: 81-3-3491-9741, FAX: 81-3-3493-2933
<http://www.hirose.com>
<http://www.hirose-connectors.com>

Looking for pricing, stock, or lifecycle information?

Click below to explore more details on WIN SOURCE:

- ⊖ [View QR/P17-SCA-111\(50\) on WIN SOURCE](#)
- ⊖ [Hirose Electric Co Ltd Information](#)

Optimize Your Supply Chain with WIN SOURCE Solutions

- ✓ Global Sourcing Solution
- ✓ Obsolete Management
- ✓ Cost Control Management
- ✓ Shortage Management
- ✓ Alternative Solution
- ✓ Excess Inventory Management